

ASCEND

WIDELINE DESIGNER RANGE

TECHNICAL GUIDE



WIDELINE
WINDOWS & DOORS



CONTENTS

Take a closer look	4
<hr/>	
Ascend windows	
<hr/>	
Sliding window	8
<hr/>	
Awning window	10
<hr/>	
Casement window	12
<hr/>	
Fixed panel window	14
<hr/>	
Ascend doors	
<hr/>	
Sliding door	16
<hr/>	
Sliding stacking door	18
<hr/>	



TAKE A CLOSER LOOK



WELCOME TO AN EXCITING NEW STANDARD OF ALUMINIUM WINDOWS AND DOORS

WITH THE INTEGRITY AND SLEEK DESIGN AESTHETIC OF WIDELINE'S PARAGON ARCHITECTURAL SUITE, ASCEND IS A STYLISH UPGRADE FROM THE STANDARD HORIZON RESIDENTIAL RANGE.

The Ascend designer range features robust frames and a stylish selection of handles offering you the ultimate flexibility to create the look you want.

Delivering architectural lines and clean, well balanced design, Ascend windows and doors will add style and sophistication to your home.

Choose the Ascend 25 for residential installation, or Ascend 40 for commercial sub-framing installation.

Tested for safety, energy efficiency and quality, every Wideline product is backed by a comprehensive written 7 year guarantee.

Advanced technology, innovation and beauty are the hallmarks of the Wideline range. From every angle, Ascend is designed to impress.



THE KNOW-HOW BEHIND OUR WINDOWS AND DOORS

BUILDERS AND ARCHITECTS KNOW THAT THERE IS MORE TO WIDELINE'S WINDOWS AND DOORS THAN MEETS THE EYE. THE SIMPLE ELEGANT DESIGNS BELIE THE SCIENCE AND TECHNOLOGY THAT IS PRESENT IN EVERY PRODUCT.

You can feel safe in the knowledge that every Wideline product has been rigorously researched and tested to ensure the very best performance in Australian conditions.

Build quality

Wideline has been making windows and doors at our manufacturing premises in NSW for over 45 years. Our range of windows and doors are built from the highest quality materials and finishes.

All windows and doors are designed to be durable and easy to operate without compromising on their aesthetic appeal. They are backed by a comprehensive warranty and offer exceptional quality and value.

Energy efficiency

All our windows and doors have been expertly tested through the window energy rating scheme [WERS] and are designed to enhance the comfort of your home and reduce energy costs by actively insulating your home from temperature extremes.

Glass

Glass technology has advanced dramatically in recent years.

Wideline offer a comprehensive range of glazing options. The right glazing option can provide:

- Added strength and security
- Improved energy efficiency
- Self cleaning
- Improved comfort
- Improved privacy.

SecureLine™ security screens

Enjoy clear, unobstructed views whilst keeping your home safe and secure with SecureLine™ security screens.

Offering the ultimate in security without compromising on your view or design, SecureLine™ screens are made from the highest quality marine grade stainless steel mesh. SecureLine™ has surpassed all of the requirements of the Australian Security Door Standard AS5039 - 2008.

Insect and safety screens

Keeping the 'outdoors', outdoors is essential in Australia's natural environments.

Our insect and safety screens protect you from just about everything from bugs to bushfires. BarrierLine™ safety grilles offer cost effective solutions to help increase the security of your home by offering a visual barrier from would-be intruders. A selection of mesh types are available such as fibreglass, aluminium and stainless steel.

SafeLine™ fall prevention screens

In 2013 it became mandatory in NSW to fit fall prevention devices to bedroom windows more than two metres above the outside ground level.

There is no compromise when it comes to your child's safety. Wideline understands this and has developed SafeLine™ fall prevention screen specifically with your family's safety in mind. No longer do you need to restrict your window opening for peace of mind. SafeLine™ allows openable windows to operate as they were intended, allowing airflow when you want it without risking the safety of your family. Made from a robust aluminium frame and resilient Dacron mesh for maximum strength and durability. SafeLine™ has been independently verified by NATA accredited laboratories to exceed Australian Standards and readily complies with the National Construction Code.

Bushfire protection

Wideline have solutions for all bushfire attack levels up to and including BAL-40.

Acoustics

The advancements in glazing have dramatically improved home acoustics. Wideline have a range of solutions to help bring the peace and quiet back into your home.

STATE OF THE ART POWDER COAT FACILITY

WIDELINE'S STATE OF THE ART POWDER COAT FACILITY REDUCES ENERGY AND RESOURCE CONSUMPTION WHILE PRODUCING HIGHER QUALITY PRODUCTS.

Our paint plant is one of the first facilities in Australia to introduce chrome-free technology. Eliminating chrome requires improved operational control and greater precision in other parts of the production process, but the extra effort is well worth it. We've been able to eliminate a potentially hazardous material, reduce effluent and produce a cleaner and more environmentally sensitive product.

Products produced without using chrome have a lighter coating, so there is less chance of unsightly 'build up' on the metal surface. Surface imperfections and inclusions are virtually eliminated, creating a product with near perfect visual appearance.

Our new facility has significantly enhanced productivity and efficiency. Improvements to the Powder Coat Facility include:

- Reusing residual heat from the curing oven to dry treated profile immediately before powder coating – a significant reduction in energy requirements.
- Improved gun technology to enhance powder transfer efficiency.
- Increased production capacity by 25%.

Wideline's Powder Coat Facility is certified as meeting Australian Standard AS3715 'Metal Finishing – Thermoset powder coating for architectural applications of aluminium and aluminium alloys'. We use Dulux and Interpon products. Pre-treatment is tested by Chemetal.



Guaranteed Colorbond® compatible. Colour swatches are a guide only. Due to reproduction constraints colours may vary.





SLIDING WINDOW

THE ASCEND SLIDING WINDOW BOASTS SQUARE RAILS AND A SLIGHTLY WIDER FRAME THAN THE HORIZON RANGE, KEEPING A BEAUTIFUL DESIGN CONSISTENCY WITH THE SASHES.

The hardware is a defining feature of this sliding window, easy push-and-slide action with minimalist design for a sleek contemporary look.

COMPARISON

FEATURES	HORIZON	ASCEND 25	ASCEND 40
Smooth, quiet sliding action	✓	✓	✓
Interlocking mullions for added strength	✓	✓	✓
Variety of screen options	✓	✓	✓
Special sill options for extreme weather exposure	✓	✓	✓
Halo Aquashield™ compatible for light weight construction	✓	✓	
Architectural lines		✓	✓
Deep weatherproof seals as standard		✓	✓
Flush Handle option available		✓	✓
Larger robust frame for added strength		✓	✓

CONFIGURATIONS

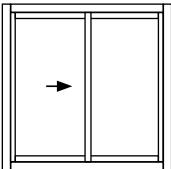
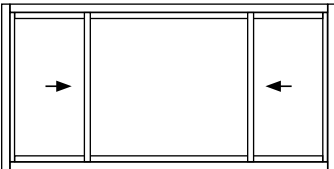
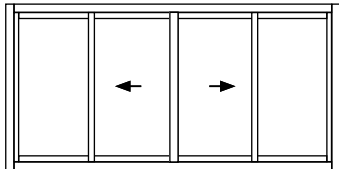
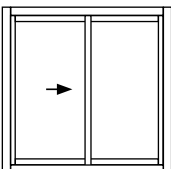
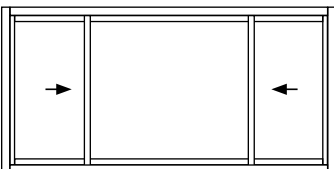
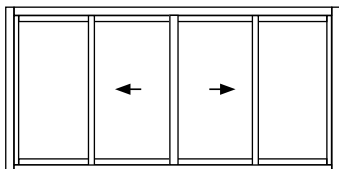
Two Lite		Three Lite		Four Lite	
(BSW-2)	(BSW40-2)	(BSW-3)	(BSW40-3)	(BSW-4)	(BSW40-4)
 <p>S/F</p>		 <p>S/F/S</p>		 <p>F/S/S/F</p>	
Two Lite Transom		Three Lite Transom		Four Lite Transom	
(BSW-2T)	(BSW40-2T)	(BSW-3T)	(BSW40-3T)	(BSW-4T)	(BSW40-4T)
 <p>S/F</p>		 <p>S/F/S</p>		 <p>F/S/S/F</p>	

Note: As viewed from outside. Configurations are reversible & hilites available.



CONSTRAINTS

		ASCEND 25	ASCEND 40
Maximum Water Rating		300Pa	450Pa
Glazing Thickness		4mm - 20mm	4mm - 20mm
Frame	Depth	100mm	100mm
	Height	488mm - 2700mm	518mm - 3000mm
	Width	850mm - 4800mm	850mm - 4800mm
Sash	Height*	400mm - 1800mm	400mm - 1800mm
	Width*	412mm - 1600mm 836mm - 2000mm (<i>BSW-3 Fixlite</i>)	412mm - 1600mm 836mm - 2000mm (<i>BSW-3 Fixlite</i>)
	Maximum Aspect Ratio	3.5	3.5
	Maximum Weight	200kg	200kg

* Subject to site conditions and wind load pressures.

SCREENS

Standard Fly Screen compatible	✓
BarrierLine™ Safety Screen	✓
SafeLine™ Fall Prevention Screen	✓
SecureLine™ Security Screen	✓

HARDWARE

COLOURS	AUSTRAL PEARL LOCK
Black Matt	✓
Anodic Silver	✓
Pearl White	✓

FRAME – ASCEND 25



FRAME – ASCEND 40



AWNING WINDOW

THE ASCEND AWNING WINDOW DELIVERS ARCHITECTURAL LINES OFFERING A CLEAN, WELL BALANCED AESTHETIC AND IS THE PERFECT ADDITION TO ANY HOME.

Robust frame and double perimeter sash seals provide perfect protection in inclement weather.

Incorporate fixlites, hilites or lowlites for larger window expanses.

COMPARISON

FEATURES	HORIZON	ASCEND 25	ASCEND 40
Variety of screen options	✓	✓	✓
Key locking system in various openable positions	✓	✓	✓
Allows airflow even in inclement weather	✓	✓	✓
Halo Aquashield™ compatible for light weight construction	✓	✓	
Glazing options up to 24mm for improved noise control and energy efficiency		✓	✓
Architectural lines		✓	✓
Double perimeter sash seals for added weather protection		✓	✓

CONSTRAINTS

PERFORMANCE		WITHOUT SIDE WINDOW LATCHES	WITH SIDE WINDOW LATCHES
Maximum N Rating (Housing)		N3 Corner	N4 Corner N5 General
Maximum Serviceability (Residential and Commercial)		1500Pa	2000Pa
Maximum Water	Ascend 25	450Pa	600Pa
	Ascend 40	300Pa	450Pa
Maximum Ultimates		2000Pa	3000Pa
Glazing Thickness		4mm - 24mm	4mm - 24mm

SIZE		SINGLE CHAINWINDER	TWIN CHAINWINDER
Sash	Height	250mm - 2100mm	250mm - 2100mm
	Width	340mm - 1350mm	900mm - 2400mm
	Maximum Area	1.72m ²	1.72m ²
	Maximum Weight	35kg	35kg

Note: Subject to site conditions and wind load pressures.



CONSTRAINTS

HARDWARE ¹		SASH WIDTH	MAXIMUM SASH HEIGHT
BAW-301 TO 310	Chainwinder Lockable S/S	340mm - 1350mm	2100mm
BAW-311 TO 321	Twin Chainwinder	900mm - 2400mm	2100mm
BCW-302 TO 309	Window Latch L/R	340mm - 900mm	2100mm
BCW-302 TO 309 (x2)	Window Latch L/R	900mm - 1800mm	2100mm

SASH STAYS ²	SASH HEIGHT	MAXIMUM SASH WEIGHT
AAW-017	250mm - 350mm	12kg
AAW-018	300mm - 450mm	14kg
AAW-019	350mm - 550mm	16kg
AAW-020	450mm - 800mm	20kg
AAW-021	550mm - 1200mm	24kg
AAW-022	650mm - 2100mm	35kg

Note: Sash sizes will also be affected by weight capability of friction stays:

1. Hardware: Chainwinder Lockable S/S Chain for sash widths between 340mm - 1350mm only. Twin Chainwinder for sash widths between 900mm - 2400mm. 2. Sash Stays: based on 4mm Glazing. Refer to a Wideline Sales Executive for further information.

SCREENS

Standard Fly Screen compatible	✓
BarrierLine™ Safety Screen	✓
SafeLine™ Fall Prevention Screen	✓
SecureLine™ Security Screen	✓

HARDWARE

COLOURS	CHAINWINDER LOCKABLE S/S, TWIN CHAINWINDER, WINDOW LATCH L/R
Black Matt	✓
Anodic Silver	✓
Pearl White	✓

FRAME – ASCEND 25

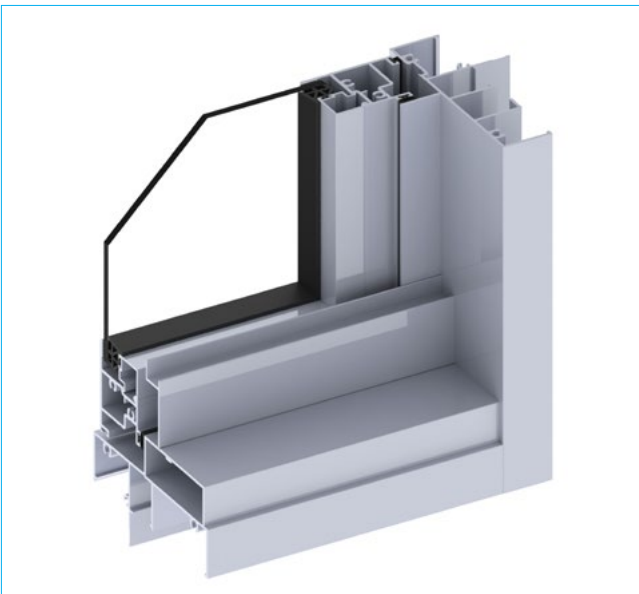

FRAME – ASCEND 40

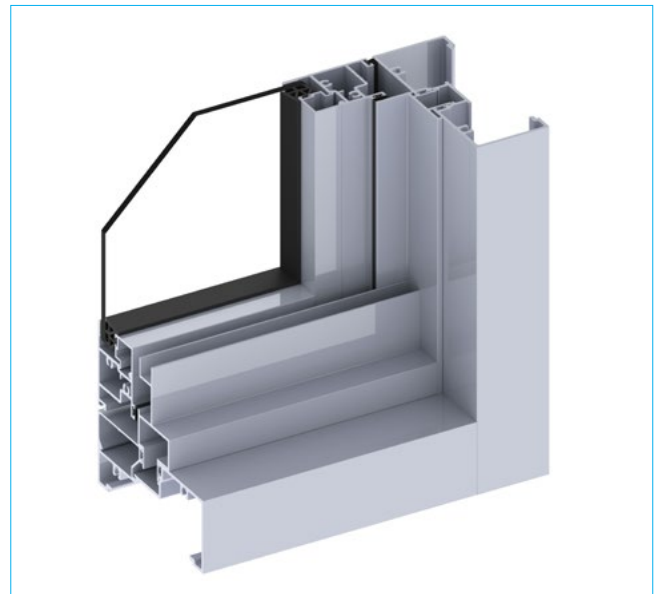

CASEMENT WINDOW

THE ASCEND CASEMENT WINDOW ADDS STYLE, SOPHISTICATION AND CONTROLLED VENTILATION TO YOUR HOME.

Includes double perimeter sash seals for inclement weather and improved acoustics.

Incorporate fixlites, hilites or lowlites for larger window expanses.

COMPARISON

FEATURES	HORIZON	ASCEND 25	ASCEND 40
Variety of screen options	N/A	N/A	N/A
Halo Aquashield™ compatible for light weight construction	N/A	✓	
Glazing options up to 24mm for improved noise control and energy efficiency	N/A	✓	✓
Key locking system for added security	N/A	✓	✓
Allows airflow even in inclement weather	N/A	✓	✓
Architectural lines	N/A	✓	✓
Full perimeter sash seals for added weather protection	N/A	✓	✓
Incorporate fixlites, hilites or lowlites for larger window expanses.	N/A	✓	✓

CONSTRAINTS

PERFORMANCE	SINGLE SIDE CAM	DOUBLE SIDE CAMS
Maximum N Rating (Housing)	N3 Corner	N4 Corner N5 General
Maximum Serviceability (Residential and Commercial)	1000Pa	1000Pa
Maximum Water	300Pa	300Pa
Maximum Ultimates	2000Pa	3000Pa
Glazing Thickness	4mm-24mm	4mm-24mm

SIZE

Sash	Height	250mm - 1500mm
	Width	350mm - 800mm
	Maximum Area	1.34m ²
	Maximum Weight	30kg

Note: Subject to site conditions and wind load pressures.



CONSTRAINTS

SASH STAYS ¹	SASH HEIGHT	MAXIMUM SASH WEIGHT
BCW-300	350mm - 650mm	24kg
BCW-301	460mm - 800mm	30kg

Note: Sash sizes will also be affected by weight capability of friction stays:

1. Sash Stays: based on 4mm - 10mm Glazing. Refer to a Wideline Sales Executive for further information.

HARDWARE

COLOURS	CHAINWINDER LOCKABLE S/S, TWIN CHAINWINDER, WINDOW LATCH L/R
Black Matt	✓
Anodic Silver	✓
Pearl White	✓

FRAME – ASCEND 25

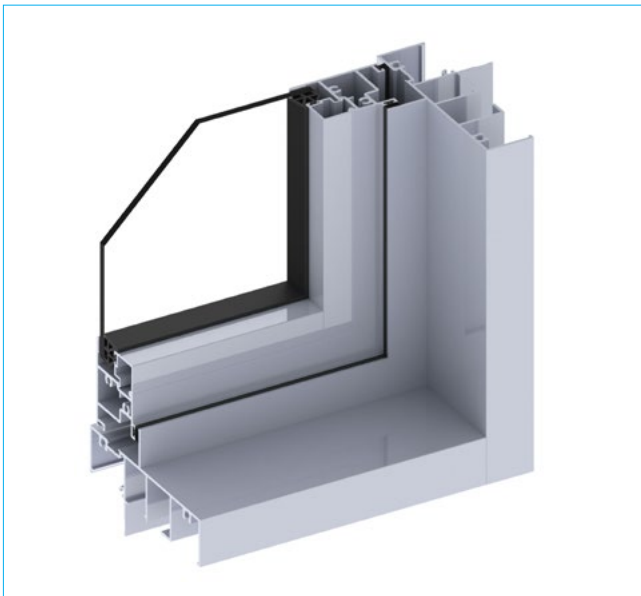

FRAME – ASCEND 40



FIXED PANEL WINDOW

FIXED WINDOWS ARE A DRAMATIC WAY TO CREATE A FEATURE OF YOUR SURROUNDINGS OR ENHANCE A PARTICULAR STYLE.

Frame that perfect view or add hillites to provide an abundance of light whilst keeping your privacy, ideal for bedrooms where neighbours are close or share a similar window.

Ascend fixed windows have robust frames and architectural lines allowing you to achieve a stylish look for your home.

COMPARISON

FEATURES	HORIZON	ASCEND 25	ASCEND 40
Frame a view with no interruption	✓	✓	✓
Glazing options up to 24mm for improved noise control and energy efficiency		✓	✓
Flexibility for size up to very large expanses		✓	✓
90° and 180° silicone joints		✓	✓

FRAME – ASCEND 25

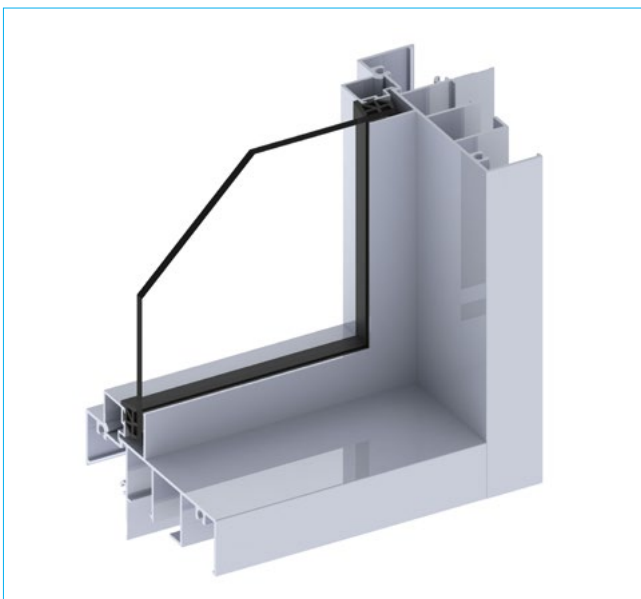

FRAME – ASCEND 40

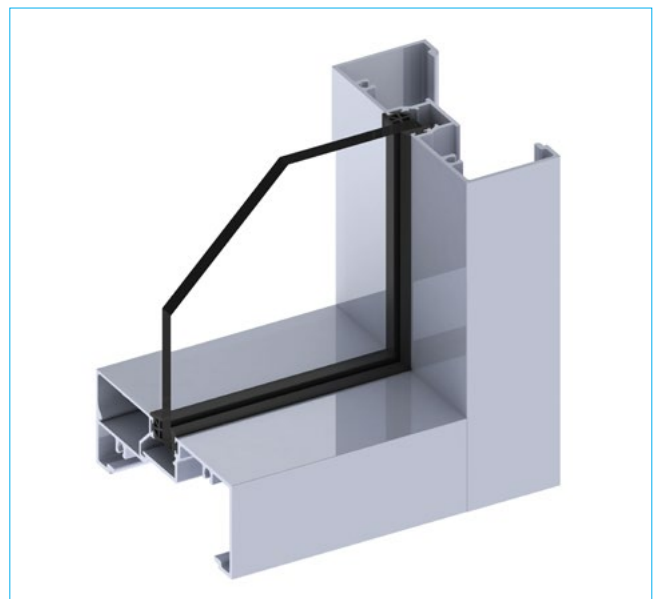



SLIDING DOOR

STRONG SQUARE RAILS AND UNIFORM STILE THICKNESS MAKE FOR A BEAUTIFULLY BALANCED AND EYE PLEASING DESIGN ON THE ASCEND SLIDING DOOR.

Wideline's sliding doors provide a greater use of floor space. A wide door opening that can be left open in strong breezes without the fear of slamming.

COMPARISON

FEATURES	HORIZON	ASCEND
Smooth, quiet sliding action	✓	✓
Variety of screen options	✓	✓
Self-draining sills	✓	✓
Disability sill available	✓	✓
Halo Aquashield™ compatible for light weight construction	✓	✓
Flexible sizes for greater height, width and panel sizes		✓
Maximum frame height 2700mm		✓
Maximum frame width 6000mm		✓

CONFIGURATIONS

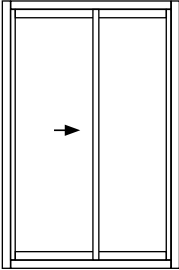
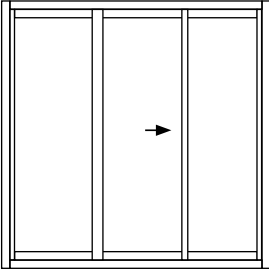
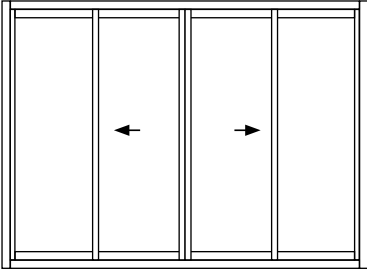
Two Lite (BSDI-2)	Three Lite (BSDI-3)	Four Lite (BSDI-4)
 <p>S/F</p>	 <p>F/S/F</p>	 <p>F/S/S/F</p>

Note: As viewed from outside. Configurations are reversible & hilites available.



CONSTRAINTS

Maximum Water Rating		450Pa
Glazing Thickness		4mm - 20mm (6.38mm Standard)
Frame	Depth	100mm
	Maximum Height*	2700mm
	Maximum Width*	6000mm
	Maximum Transom Span*	3000mm
Panel	Maximum Height*	2650mm
	Width*	1600mm
	Maximum Aspect Ratio	3.5
	Maximum Weight	300kg

* Subject to site conditions and wind load pressures.

SCREENS

Standard Fly Screen compatible	✓
BarrierLine™ Safety Screen	✓
SecureLine™ Security Screen	✓

HARDWARE

COLOURS	DORIC DS3130 Timbarra	DORIC DS3010 Carey (Slimline)
Black Matt	✓	✓
Stainless Steel	✓	
Stone Beige Satin	✓	✓
Satin Chrome	✓	✓
Surfmist	✓	✓
Pearl White	✓	✓

FRAME

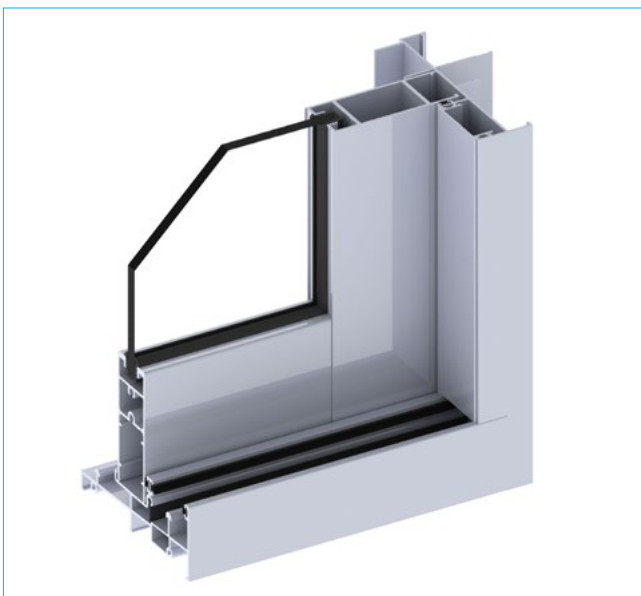

SLIDING STACKING DOOR

BRING THE OUTDOORS IN WITH LARGE EXPANSES OF UP TO 9.3M WIDE AND 2.7M HIGH. SQUARE RAILS AND UNIFORMED STILE THICKNESS FRAME YOUR VIEW PERFECTLY.

The Ascend sliding stacking door comes in 3 and 6 panel configurations as well as 90° corner door configurations for the perfect entertaining space.

COMPARISON

FEATURES	HORIZON	ASCEND
Variety of screen options	✓	✓
Non-individually glazed decorative bar options available	✓	
Individually glazed decorative bar options available		✓
Heavy duty sill as standard		✓
Multiple options for height, width and panel sizes		✓
Maximum frame height 2700mm		✓
Maximum frame width 9300mm		✓

CONFIGURATIONS

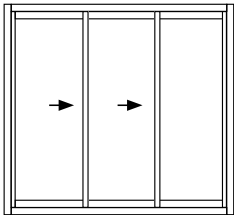
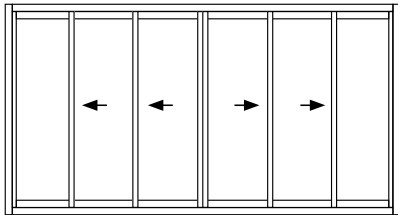
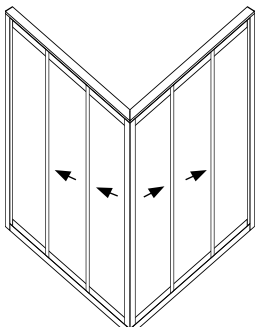
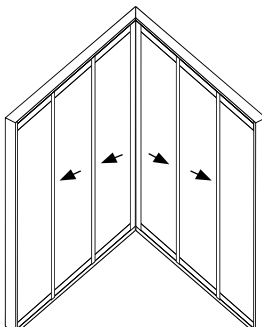
Three Lite (BSSD-3)	Six Lite (BSSD-6)
 <p>S/S/F</p>	 <p>F/S/S/S/S/F</p>
Six Lite Internal (BSSD-3 INTERNAL)	Six Lite External (BSSD-6 EXTERNAL)
 <p>F/S/S/S/S/F</p>	 <p>F/S/S/S/S/F</p>

Note: As viewed from outside. Configurations are reversible & hilites available.



CONSTRAINTS

Maximum Water Rating		300Pa
Glazing Thickness		4mm - 20mm (6.38mm Standard)
Frame	Depth	162mm (incl. Fly Frame); 105mm (excl. Fly Frame)
	Maximum Height*	2700mm
	Maximum Width*	4600mm (BSSD-3); 9300mm (BSSD-6)
Panel	Maximum Height*	2650mm
	Width*	1600mm
	Maximum Aspect Ratio	3.5
	Maximum Weight	300kg

* Subject to site conditions and wind load pressures.

SCREENS

Standard Fly Screen compatible	✓
BarrierLine™ Safety Screen*	✓
SecureLine™ Security Screen*	✓

* Not available for 90° Doors.

HARDWARE

COLOURS	DORIC DS3130 Timbarra	DORIC DS3010 Carey (Slimline)
Black Matt	✓	✓
Stainless Steel	✓	
Stone Beige Satin	✓	✓
Satin Chrome	✓	✓
Surfmist	✓	✓
Pearl White	✓	✓

FRAME

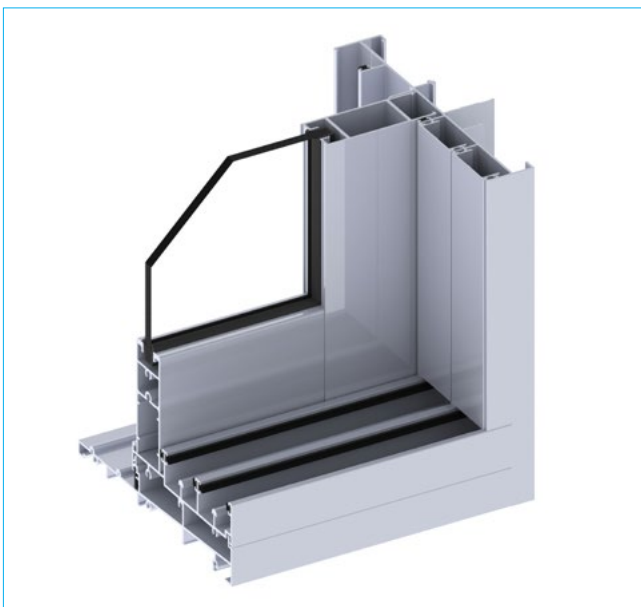



CENTRAL COAST

TUGGERAH

Registered Head Office
174 Pacific Highway
Tuggerah NSW 2259

SYDNEY REGION

LIVERPOOL

12 Homepride Avenue
Warwick Farm NSW 2170

ROSEBERY

Shop 1, 593 Botany Road
Rosebery NSW 2018

REGIONAL

NEWCASTLE

107 Broadmeadow Road
Broadmeadow NSW 2292

PORT MACQUARIE

28 Janola Circuit
Port Macquarie NSW 2444

WIDELINE PTY LTD | ABN 11 000 945 068

For more information call 1300 943 354 | wideline.com.au

Visit our website and virtual showroom to view our complete product range and find out more about choosing the perfect windows for your home.

