

HOMETEC SHUTTERS PRE-MACHINED ALUMINIUM FIXED SHUTTER PATENTED SYSTEM

DRAWING 3.

* LUBRICATE ALL SCREWS FOR EASE OF ASSEMBLY

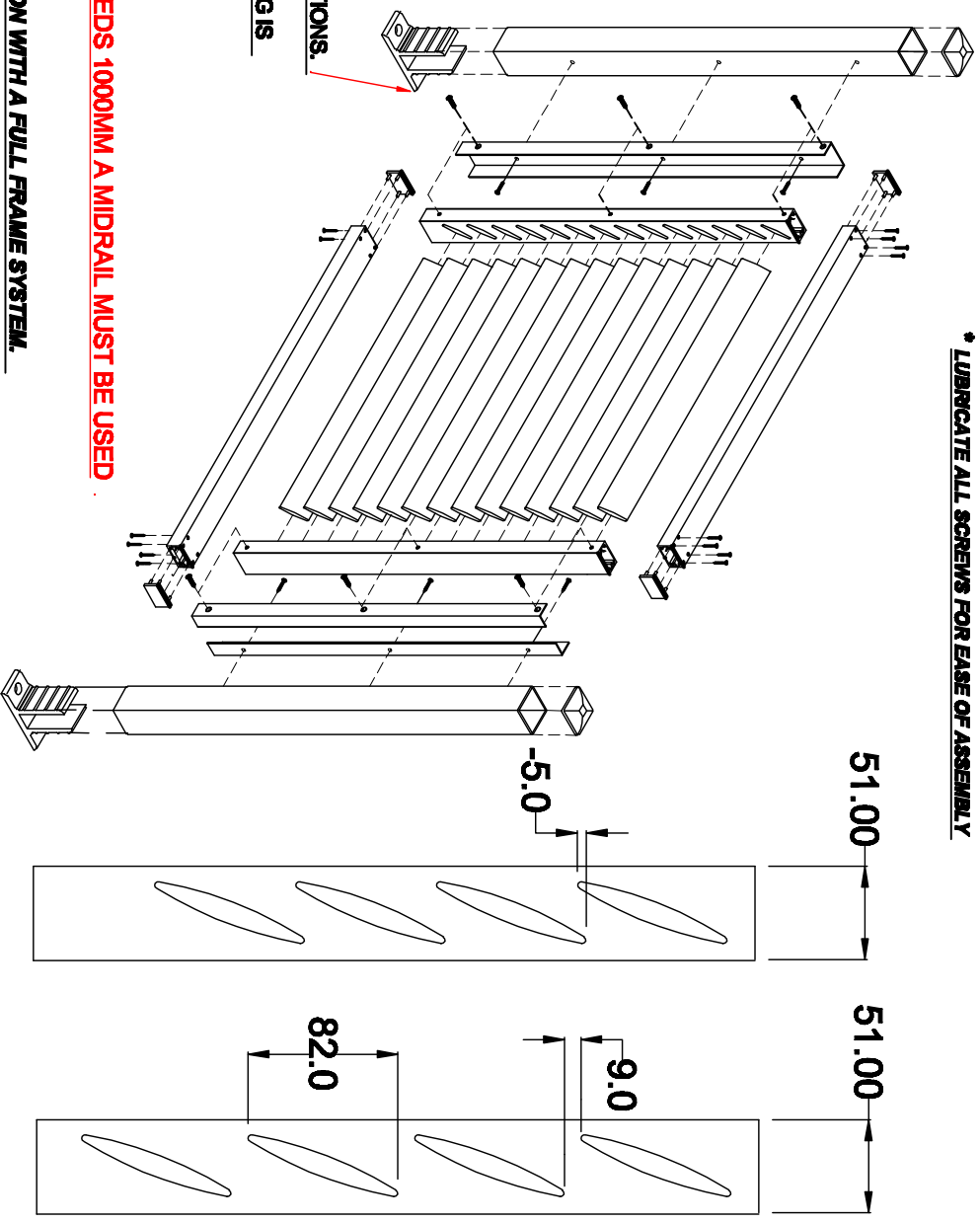

NOTE. CAST FEET ARE NOT TO BE USED IN STRUCTURAL SITUATIONS.
IF STRUCTURAL REQUIREMENTS ARE TO BE MET, USE A 10MM
EXTRUDED FLAT PLATE WELDED TO THE FRAME. IF ENGINEERING IS
REQUIRED CONSULT OWN ENGINEER.



NOTE... WHEN THE WIDTH OF THE PANEL EXCEEDS 1000MM A MIDRAIL MUST BE USED.

IMPORTANT... A MID RAIL MUST BE USED IN CONJUNCTION WITH A FULL FRAME SYSTEM.

ADD APPROX. 30MIN. ASSEMBLY TIME WHEN MID RAIL IS USED.

HOMETEC 88MM BLADE

-5MM and 9MM SPACE

**13 BLADES
PER LM**

**12 BLADES
PER 1.0 LM**

1 APRIL 2010