





C. Harn Drawer Systems



Ham Drawer Systems – Contents

<p>TRIOMAX INDEX PAGE</p>	<p>C.4</p>	
<p>TRIOMAX DRAWER SYSTEM</p>	<p>C.3-C.38</p>	
<p>TRIOMAX PRICELIST</p>	<p>C.29-C.38</p>	
<p>IMPAZ INDEX PAGE</p>	<p>C.40</p>	
<p>IMPAZ DRAWER SYSTEM</p>	<p>C.39-C.57</p>	



Ham Drawer Systems – Contents

BASIC SLIDES	C.58	
OFFICELINE DRAWER SYSTEM	C.59-C.62	
MARKING DEVICES	C.63-C.64	
BRACKET INSERTION TOOLS	C.65	
DRILLING JIG/ TECHNICAL MANUAL	C.66	



harn **triomax** Drawer System

- 50kg Load capacity
- Full extension with synchro control
- Integrated Soft-close
- Smoother action with new dust prevention design
- Easier and faster bottom panel assembly with integrated spikes
- Effortless drawer removal with new release actuator
- Noise free drawer opening due to new roller carriage
- Enhanced slide stability with reinforced runner profile
- New double-wall shell and divider panel





Hørn - Triomax Drawer System

TRIOMAX CONTENTS



Drawer S

Standard Drawer and Inner Drawer
Drawer Height - 83

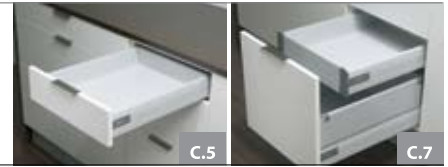

Drawer M

Railing M Standard Drawer and Railing M Inner Drawer
Drawer Height - 83



Drawer H

Double Railing H Standard Drawer and
Double Railing H Inner Drawer
Drawer Height 83



Drawer H

Side Extend H Standard Drawer and
Side Extend H Inner Drawer
Drawer Height 83



Drawer M / Drawer H

Divider Panel and Divider Railing
Drawer Height 83



Side Extension / Cross Railing



Pantry Unit



Filing System

Drawer Height 83



Steel Back

C.37

Assembly and Adjustment

C.27

Assembly, Insertion and Removal

C.28

Marking Devices

C.63

Drilling Jig / Technical Manual

C.66

Bracket Insertion Tool

C.65

Price List

C.29







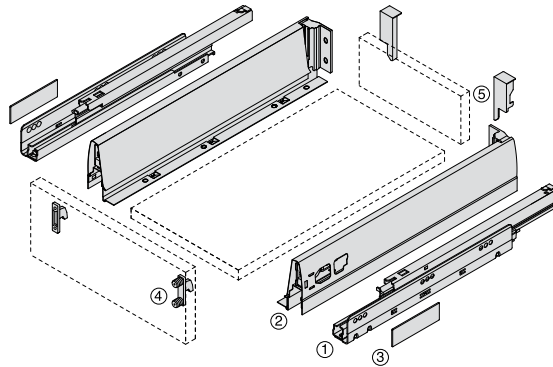

TRIOMAX Standard Drawer - S



- Available in white & metallic grey
- Roller bearing concealed runners
- Full extension with synchro control
- Steel drawer side 83mm
- Load capacity of 50kg
- Quick assembly
- Flexible 2-dimensional front adjustment
- **Sylent** integrated cushioning system
- Integrated stabilizer

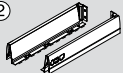

①		Carcase Profiles Left / Right : electro galvanised
Drawer Length		
270mm		TM46.27
350mm		TM46.35
400mm		TM46.40
450mm		TM46.45
500mm		TM46.50
550mm		TM46.55
③		Cover Cap
		RBC.62030.DG
④		Front Fixing Brackets
	 Screw-on	RBF.21030
	 Press-in	RBF.22030
	 Expansion	RBF.23030
⑤		Rear Fixing Brackets
		RBR.76030R
		RBR.76030L
	Steel Back	See Page C.37

②		Drawer Side Left / Right :
		TD36.27
		TD36.35
		TD36.40
		TD36.45
		TD36.50
		TD36.55



Harn - Triomax Drawer System

Space Requirements and Front Installation Dimensions

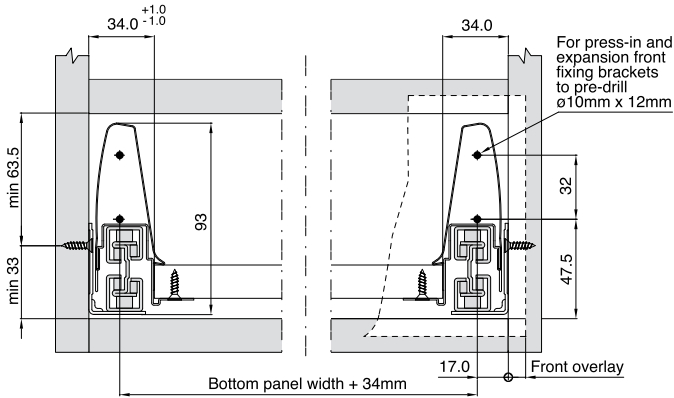

Back Installation Dimensions

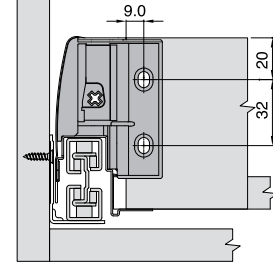

triomax

Cabinet Profile Fixing Positions

Drawer Length

270 mm

350 mm

400 mm

450 mm

500 mm

550 mm

Min. internal cabinet depth = drawer length + 3 mm
Actual loss of extension = 0 mm

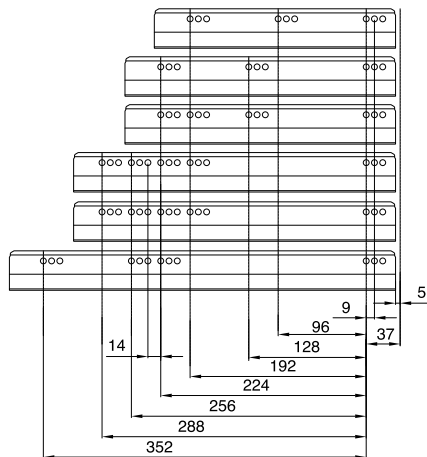

Cutting Dimensions for 16mm Chipboard

Back panel

Width = internal cabinet width - 79mm
Height = 84mm

Bottom panel

Width = Internal cabinet width - 68mm
Length (wooden back) = drawer length - 24 mm
Length (steel back) = drawer length - 22 mm

Pre-drilling Dimension of Bottom Panel for Fixing Euro Screws

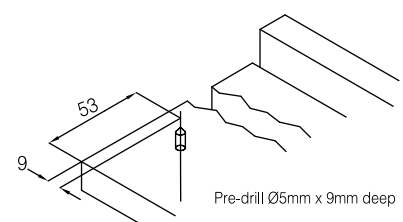

BACK



TRIOMAX Standard Inner Drawer - S



- Available in white & metallic grey
- Roller bearing concealed runners
- Full extension with synchro control
- Steel drawer side 83mm
- Load capacity of 50kg
- Quick assembly
- **Sylent** integrated cushioning system
- Integrated stabilizer

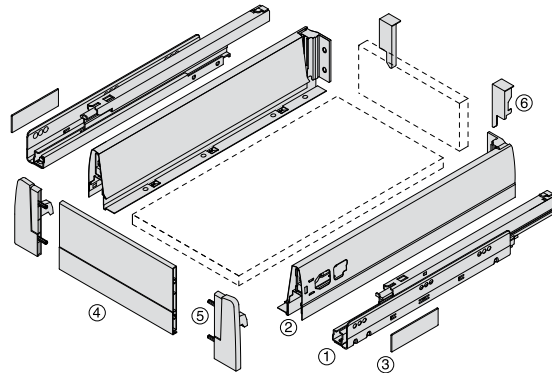

①	Carcase Profiles Left / Right : electro galvanised	②	Drawer Side Left / Right :
Drawer Length			
270mm	TM46.27		TD36.27
350mm	TM46.35		TD36.35
400mm	TM46.40		TD36.40
450mm	TM46.45		TD36.45
500mm	TM46.50		TD36.50
550mm	TM46.55		TD36.55
③	Cover Cap	⑥	Rear Fixing Brackets
	RBC.62030.DG		RBR.76030R RBR.76030L
④	Front Panel	Steel Back	See Page C.37
	Cabinet Width (16mm side panel)		
	Article No.		
	400mm		RPF860.285
	450mm		RPF860.335
	500mm		RPF860.385
	550mm		RPF860.435
	600mm		RPF860.485
	900mm		RPF860.785
	1000mm		RPF860.885
	1200mm		RPF860.1085
⑤	Front Fixing Brackets		
	RBF.56030R.DG		
	RBF.56030L.DG		

For price list see page C.29 - C.38



Horn - Triomax Drawer System

Space Requirements and Front Installation Dimensions

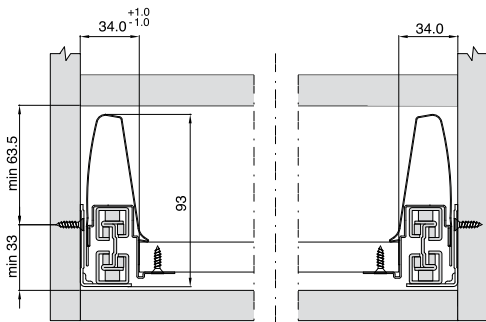

Back Installation Dimensions

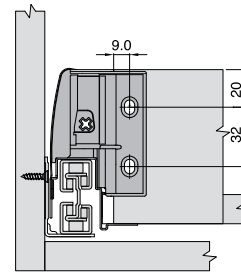

triomax

Cabinet Profile Fixing Positions

Cutting Dimensions for 16mm Chipboard

Drawer Length

- 270 mm
- 350 mm
- 400 mm
- 450 mm
- 500 mm
- 550 mm

Min. internal cabinet depth = drawer length + 12 mm
Actual loss of extension = 9 mm

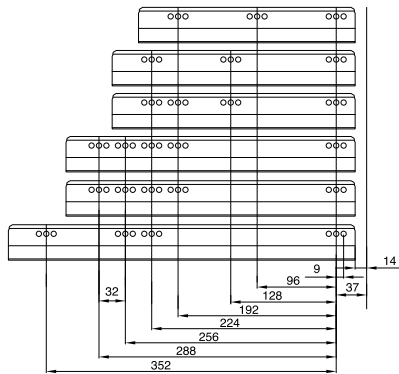

Back panel:
Width = internal cabinet width - 79mm
Height = 84mm

Bottom panel:
Width = internal cabinet width - 68mm
Length (wooden back) = drawer length - 24 mm
Length (steel back) = drawer length - 22 mm

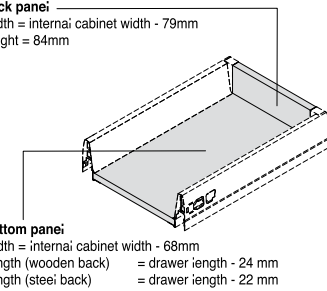

Cutting Dimensions for Front Panel

Pre-drilling Dimension of Bottom Panel for Fixing Euro Screws

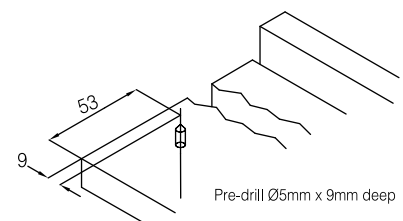
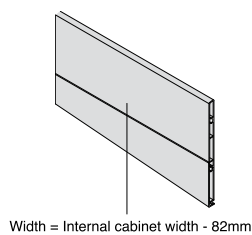





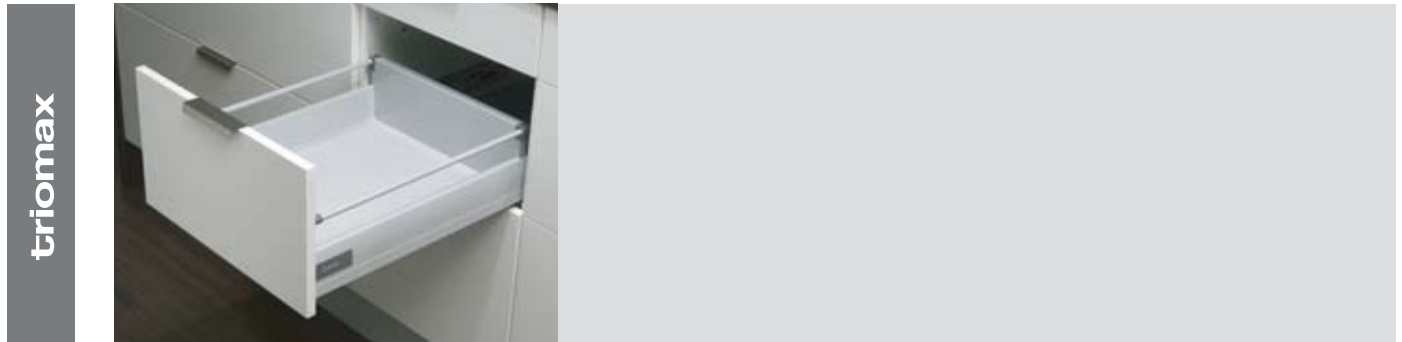

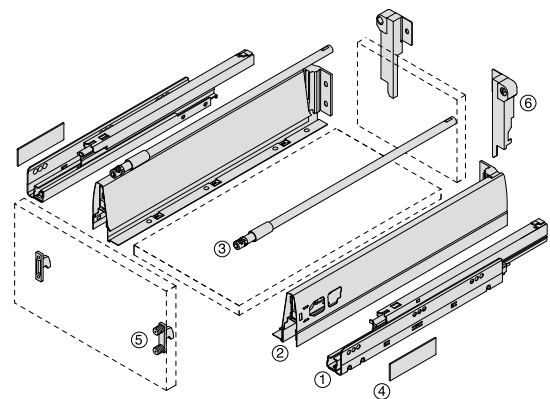

TRIOMAX Railing M Standard Drawer



- Available in white & metallic grey
- Roller bearing concealed runners
- Full extension with synchro control
- Steel drawer side 83mm
- Load capacity of 50kg
- Quick assembly
- Flexible 3-dimensional front adjustment
- **Sylent** integrated cushioning system
- Integrated stabilizer



①	Carcase Profiles Left / Right : electro galvanised	②	Drawer Side Left / Right :	③	Railing Set
Drawer Length				 Screw-on  Expansion	
350mm	TM46.35		TD36.35	RRAS.321	RRAS-E.321
400mm	TM46.40		TD36.40	RRAS.371	RRAS-E.371
450mm	TM46.45		TD36.45	RRAS.421	RRAS-E.421
500mm	TM46.50		TD36.50	RRAS.471	RRAS-E.471
550mm	TM46.55		TD36.55	RRAS.521	RRAS-E.521
④	Cover Cap				
	RBC.62030.DG				
⑤	Front Fixing Brackets				
	 Screw-on RBF.21030  Press-in RBF.22030  Expansion RBF.23030				
⑥	Rear Fixing Brackets				
	RBR.77030R				
	RBR.77030L				
	Steel Back See Page C.37				



Harn - Triomax Drawer System

Space Requirements and Front Installation Dimensions

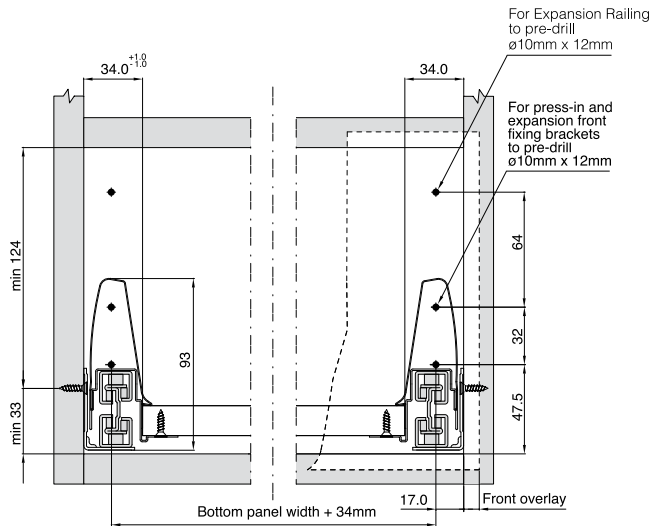

Back Installation Dimensions

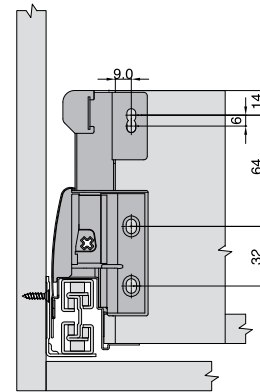

triomax

Cabinet Profile Fixing Positions

Cutting Dimensions for 16mm Chipboard

Drawer Length

- 350 mm
- 400 mm
- 450 mm
- 500 mm
- 550 mm

Min. internal cabinet depth = drawer length + 3 mm
Actual loss of extension = 0 mm

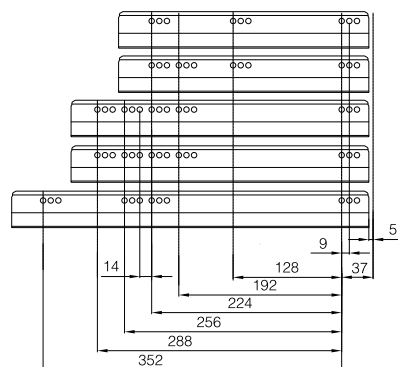

Back panel
Width = internal cabinet width - 79mm
Height = 142mm

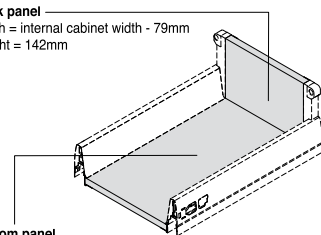

Bottom panel
Width = Internal cabinet width - 68mm
Length (wooden back) = drawer length - 24 mm
Length (steel back) = drawer length - 22 mm

Pre-drilling Dimension of Bottom Panel for Fixing Euro Screws

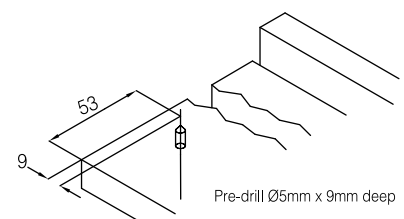

BACK



Horn - Triomax Drawer System

TRIOMAX Railing M Inner Drawer



triomax



- Available in white & metallic grey
- Roller bearing concealed runners
- Full extension with synchro control
- Load capacity of 50kg
- Load capacity of 50kg
- Quick assembly
- **Sylent** integrated cushioning system
- Integrated stabilizer

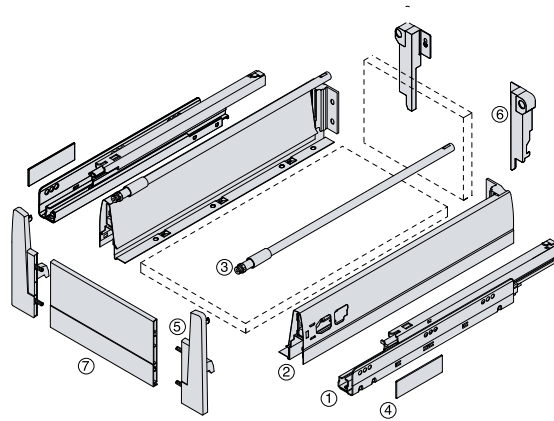

①	Carcase Profiles Left / Right : electro galvanised	②	Drawer Side Left / Right :	③	Railing Set
Drawer Length				➔ Screw-on	⊞ Expansion
350mm	TM46.35		TD36.35	RRAS.321	RRAS-E.321
400mm	TM46.40		TD36.40	RRAS.371	RRAS-E.371
450mm	TM46.45		TD36.45	RRAS.421	RRAS-E.421
500mm	TM46.50		TD36.50	RRAS.471	RRAS-E.471
550mm	TM46.55		TD36.55	RRAS.521	RRAS-E.521
④	Cover Cap RBC.62030.DG	⑦	Front Panel		
⑤	Front Fixing Brackets	Cabinet Width (16mm side panel)			
	RBF.57030R	400mm	RPF860.285		
	RBF.57030L	450mm	RPF860.335		
		500mm	RPF860.385		
		550mm	RPF860.435		
		600mm	RPF860.485		
⑥	Rear Fixing Brackets	900mm	RPF860.785		
	RBR.77030R	1000mm	RPF860.885		
	RBR.77030L	1200mm	RPF860.1085		
	Steel Back	See Page C.37			

[BACK](#) For price list see page C.29 - C.38



Harn - Triomax Drawer System

Space Requirements and Front Installation Dimensions

Back Installation Dimensions

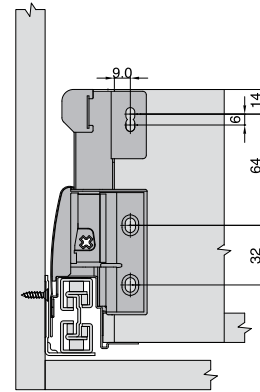
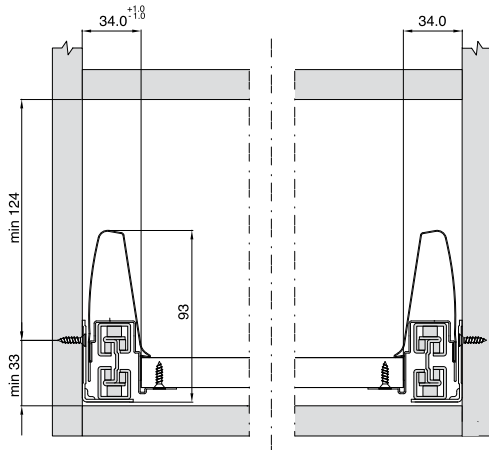

triomax

Cabinet Profile Fixing Positions

Cutting Dimensions for 16mm Chipboard

Drawer Length

- 350 mm
- 400 mm
- 450 mm
- 500 mm
- 550 mm

Min. internal cabinet depth = drawer length + 12 mm
Actual loss of extension = 9 mm

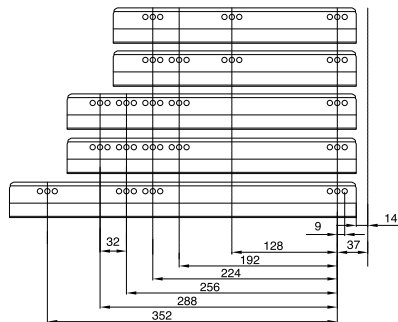

Back panel
Width = internal cabinet width - 79 mm
Height = 142 mm

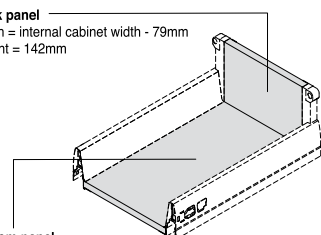

Bottom panel
Width = internal cabinet width - 68 mm
Length (wooden back) = drawer length - 24 mm
Length (steel back) = drawer length - 22 mm

Cutting Dimensions for Front Panel

Pre-drilling Dimension of Bottom Panel for Fixing Euro Screws

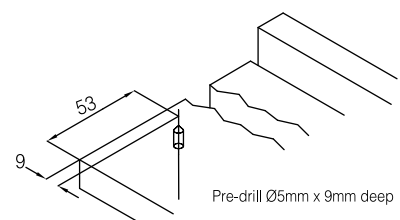
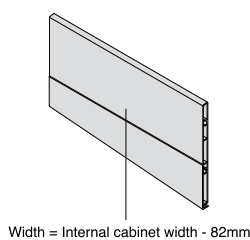







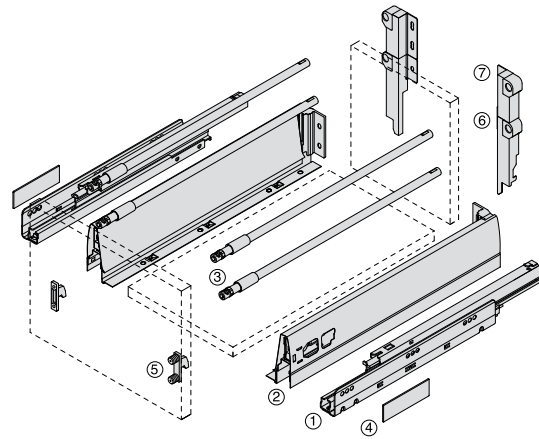

Horn - Triomax Drawer System

TRIOMAX Double Railing H Standard Drawer



- Available in white & metallic grey
- Roller bearing concealed runners
- Full extension with synchro control
- Steel drawer side 83mm
- Load capacity of 50kg
- Quick assembly
- Flexible 3-dimensional front adjustment
- **Sylent** integrated cushioning system
- Integrated stabilizer



①	Carcase Profiles Left / Right : electro galvanised	②	Drawer Side Left / Right :	③	Railing Set
Drawer Length				 Screw-on  Expansion	
350mm	TM46.35		TD36.35	RRAS.321	RRAS-E.321
400mm	TM46.40		TD36.40	RRAS.371	RRAS-E.371
450mm	TM46.45		TD36.45	RRAS.421	RRAS-E.421
500mm	TM46.50		TD36.50	RRAS.471	RRAS-E.471
550mm	TM46.55		TD36.55	RRAS.521	RRAS-E.521
④	Cover Cap RBC.62030.DG				
⑤	Front Fixing Brackets  Screw-on RBF.21030  Press-in RBF.22030  Expansion RBF.23030				
⑥	Rear Fixing Brackets RBR.77030R RBR.77030L Steel Back N/A				
⑦	Rear Fixing Brackets - add on RBR.73030R RBR.73030L				

For price list see page C.29 - C.38

BACK



Harn - Triomax Drawer System

Space Requirements and Front Installation Dimensions

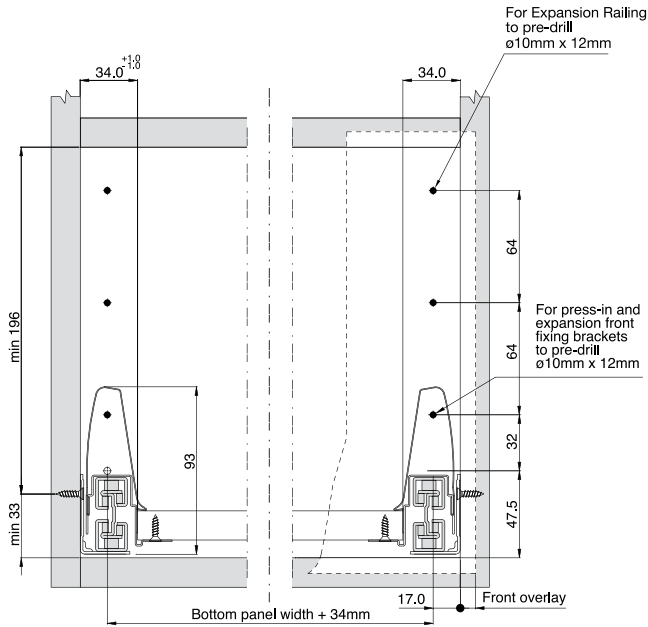

Back Installation Dimensions

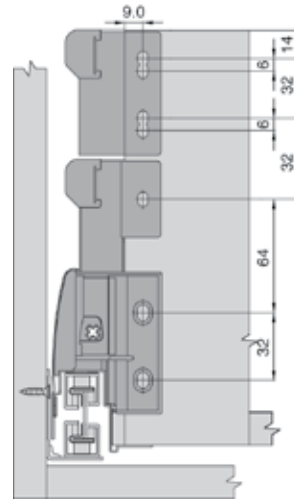

triomax

Cabinet Profile Fixing Positions

Cutting Dimensions for 16mm Chipboard

Drawer Length

- 350 mm
- 400 mm
- 450 mm
- 500 mm
- 550 mm

Min. internal cabinet depth = drawer length + 3 mm
Actual loss of extension = 0 mm

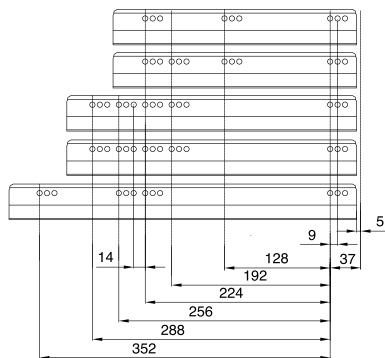

Back panel

Width = internal cabinet width - 79mm
Height = 206mm

Bottom panel

Width = Internal cabinet width - 68mm
Length (wooden back) = drawer length - 24 mm

Pre-drilling Dimension of Bottom Panel for Fixing Euro Screws

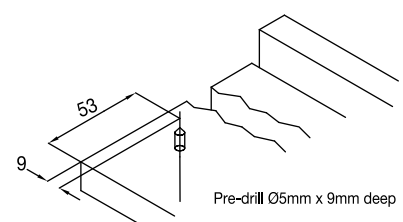

BACK



Horn - Triomax Drawer System

TRIOMAX Double Railing H Inner Drawer









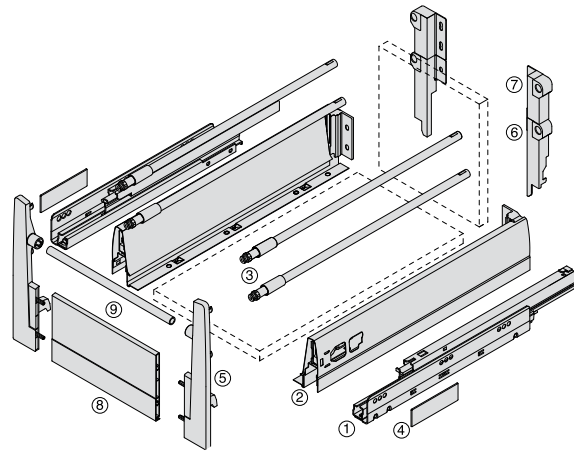

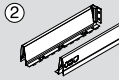
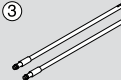
triomax



- Available in white & metallic grey
- Roller bearing concealed runners
- Full extension with synchro control
- Load capacity of 50kg
- Load capacity of 50kg
- Quick assembly
- **Sylent** integrated cushioning system
- Integrated stabilizer



	Carcase Profiles Left / Right : electro galvanised		Drawer Side Left / Right :		Railing Set
Drawer Length				 Screw-on	 Expansion
350mm	TM46.35		TD36.35	RRAS.321	RRAS-E.321
400mm	TM46.40		TD36.40	RRAS.371	RRAS-E.371
450mm	TM46.45		TD36.45	RRAS.421	RRAS-E.421
500mm	TM46.50		TD36.50	RRAS.471	RRAS-E.471
550mm	TM46.55		TD36.55	RRAS.521	RRAS-E.521
	Cover Cap RBC.62030.DG		Front Panel		Cross Railing
	Front Fixing Brackets RBF.58030R RBF.58030L	Cabinet Width (16mm side panel)			
		400mm	RPF860.285		RRF.305
		450mm	RPF860.335		RRF.355
		500mm	RPF860.385		RRF.405
		550mm	RPF860.435		RRF.455
		600mm	RPF860.485		RRF.505
		900mm	RPF860.785		RRF.805
		1000mm	RPF860.885		RRF.905
		1200mm	RPF860.1085		RRF.1105
	Rear Fixing Brackets RBR.77030R RBR.77030L				
	Steel Back				N/A
	Rear Fixing Brackets - add on RBR.73030R RBR.73030L				



For price list see page C.29 - C.38



Harn - Triomax Drawer System

Space Requirements and Front Installation Dimensions

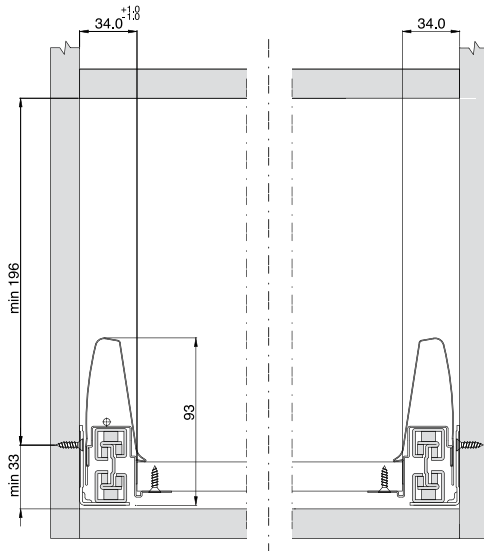

Back Installation Dimensions

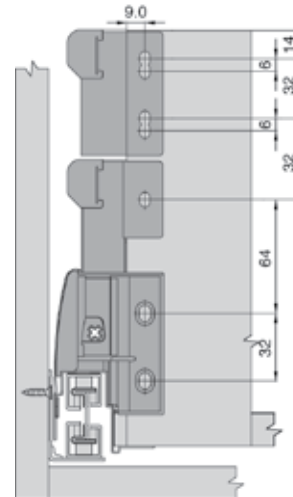

triomax

Cabinet Profile Fixing Positions

Cutting Dimensions for 16mm Chipboard

Drawer Length

350 mm

400 mm

450 mm

500 mm

550 mm

Min. internal cabinet depth = drawer length + 12 mm
Actual loss of extension = 9 mm

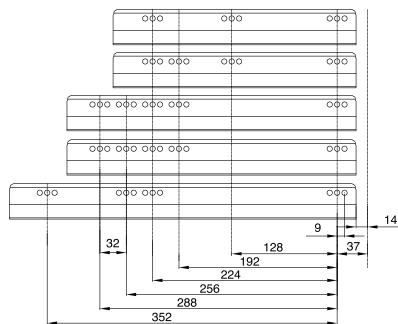

Back panel
Width = internal cabinet width - 79mm
Height = 206mm

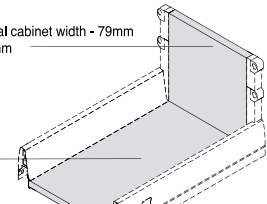

Bottom panel
Width = Internal cabinet width - 68mm
Length (wooden back) = drawer length - 24 mm

Pre-drilling Dimension of Bottom Panel for Fixing Euro Screws

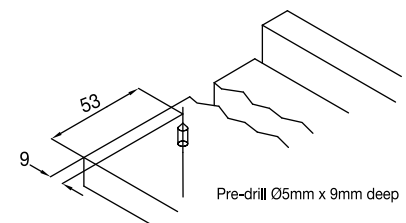

Cutting Dimensions for Front Panel

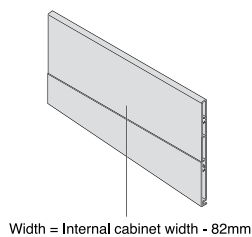

Cutting Dimensions for Cross Railing

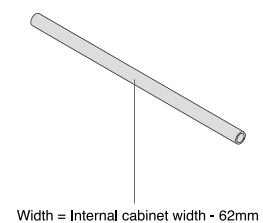



TRIOMAX Side Extension H Standard Drawer









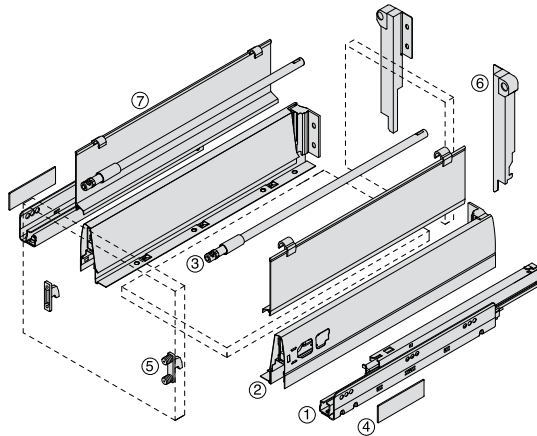



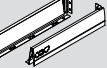





triomax



- Available in white & metallic grey
- Roller bearing concealed runners
- Full extension with synchro control
- Steel drawer side 83mm
- Load capacity of 50kg
- Quick assembly
- Flexible 3-dimensional front adjustment
- **Sylent** integrated cushioning system
- Integrated stabilizer

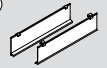

 	Carcase Profiles Left / Right : electro galvanised	 	Drawer Side Left / Right :	 	Railing Set
Drawer Length				 Screw-on	 Expansion
350mm	TM46.35	TD36.35		RRAS.321	RRAS-E.321
400mm	TM46.40	TD36.40		RRAS.371	RRAS-E.371
450mm	TM46.45	TD36.45		RRAS.421	RRAS-E.421
500mm	TM46.50	TD36.50		RRAS.471	RRAS-E.471
550mm	TM46.55	TD36.55		RRAS.521	RRAS-E.521
 	Cover Cap-plain RBC.62030. DG				
 	Front Fixing Brackets  Screw- on RBF.21030  Press-in RBF.22030  Expansion RBF.23030				
 	Rear Fixing Brackets RBR.78030R RBR.78030L Steel Back See Page C.37				
 	Side Extension				
	Drawer Length				
	350mm				RSE-H.321
	400mm				RSE-H.371
	450mm				RSE-H.421
	500mm				RSE-H.471
	550mm				RSE-H.521



For price list see page C.29 - C.38



Horn - Triomax Drawer System

Space Requirements and Front Installation Dimensions

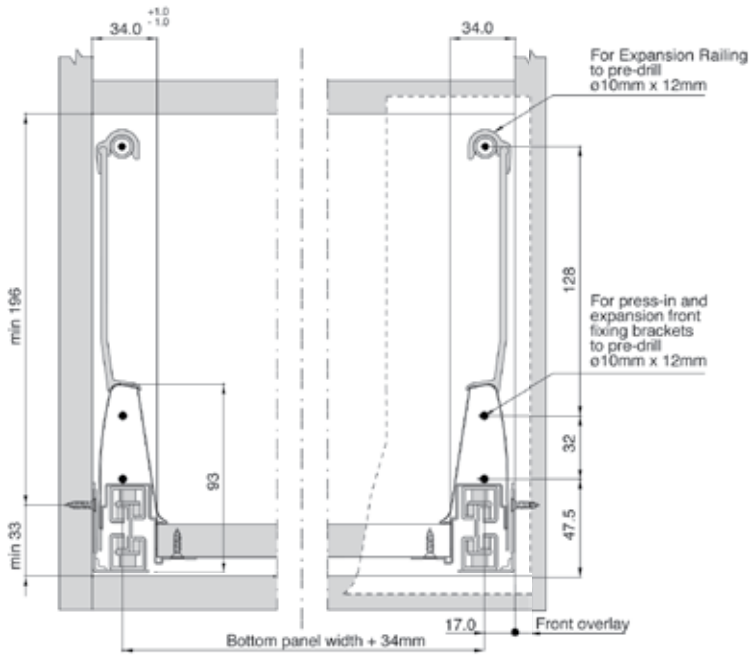

Back Installation Dimensions

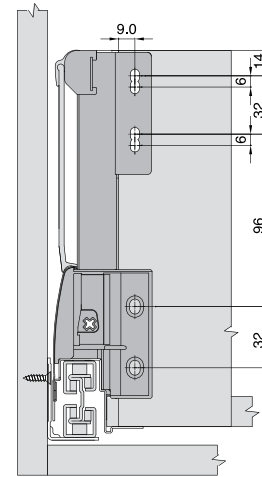

triomax

Cabinet Profile Fixing Positions

Cutting Dimensions for 16mm Chipboard

Drawer Length

- 350 mm
- 400 mm
- 450 mm
- 500 mm
- 550 mm

Min. internal cabinet depth = drawer length + 3 mm
Actual loss of extension = 0 mm

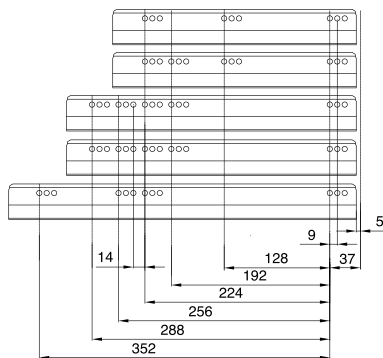

Back panel

Width = internal cabinet width - 79mm
Height = 206mm

Bottom panel

Width = Internal cabinet width - 68mm
Length (wooden back) = drawer length - 24 mm
Length (steel back) = drawer length - 22 mm

Pre-drilling Dimension of Bottom Panel for Fixing Euro Screws

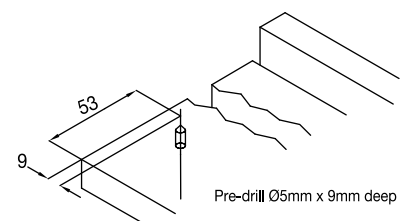

BACK



Horn - Triomax Drawer System

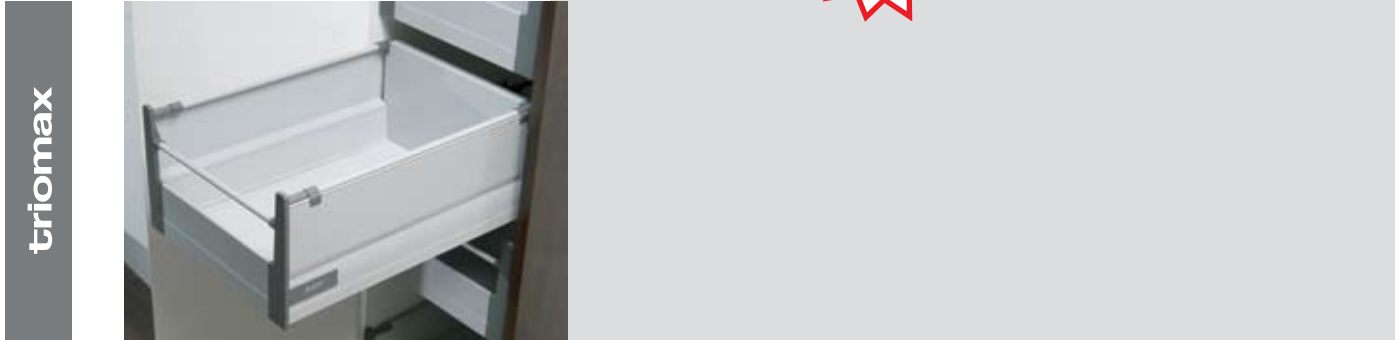

TRIOMAX Side Extension H Inner Drawer

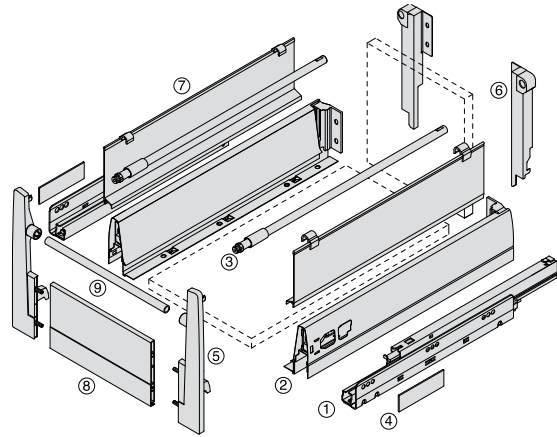

triomax

- Available in white & metallic grey
- Roller bearing concealed runners
- Full extension with synchro control
- Steel drawer side 83mm
- Load capacity of 50kg
- Quick assembly
- **Sylent** integrated cushioning system
- Integrated stabilizer

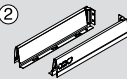
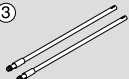

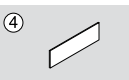
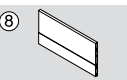
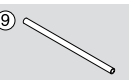
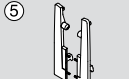
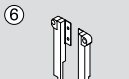
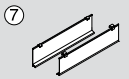
	Carcase Profiles Left / Right : electro galvanised		Drawer Side Left / Right :		Railing Set
Drawer Length				 Screw-on	 Expansion
350mm	TM46.35		TD36.35	RRAS.321	RRAS-E.321
400mm	TM46.40		TD36.40	RRAS.371	RRAS-E.371
450mm	TM46.45		TD36.45	RRAS.421	RRAS-E.421
500mm	TM46.50		TD36.50	RRAS.471	RRAS-E.471
550mm	TM46.55		TD36.55	RRAS.521	RRAS-E.521
	Cover Cap-plain RBC.62030.DG		Front Panel		Cross Railing
	Front Fixing Brackets RBF.58030R RBF.58030L	Cabinet Width (16mm side panel)			
		400mm	RPF860.285		RRF.305
		450mm	RPF860.335		RRF.355
		500mm	RPF860.385		RRF.405
		550mm	RPF860.435		RRF.455
		600mm	RPF860.485		RRF.505
		900mm	RPF860.785		RRF.805
		1000mm	RPF860.885		RRF.905
		1200mm	RPF860.1085		RRF.1105
	Rear Fixing Brackets RBR.78030R RBR.78030L Steel Back See Page C.37				
	Side Extend				
	Drawer Length				
	350mm		RSE-H.321		
	400mm		RSE-H.371		
	450mm		RSE-H.421		
	500mm		RSE-H.471		
	550mm		RSE-H.521		



For price list see page C.29 - C.38



Horn - Triomax Drawer System

Space Requirements and Front Installation Dimensions

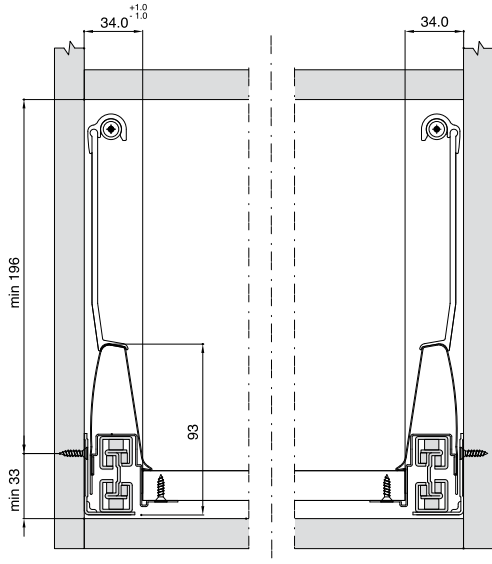

Back Installation Dimensions

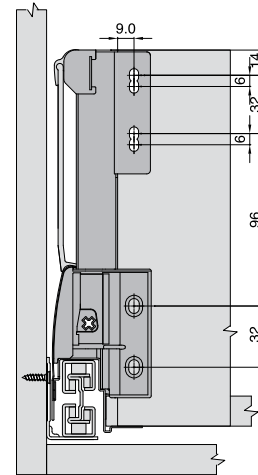

triomax

Cabinet Profile Fixing Positions

Drawer Length

- 350 mm
- 400 mm
- 450 mm
- 500 mm
- 550 mm

Min. internal cabinet depth = drawer length + 12 mm
Actual loss of extension = 9 mm

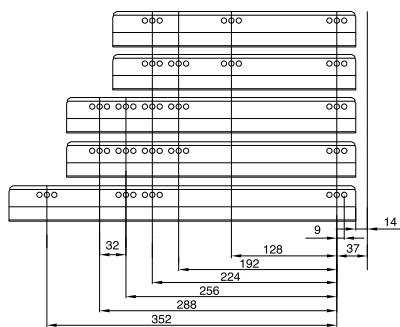

Cutting Dimensions for 16mm Chipboard

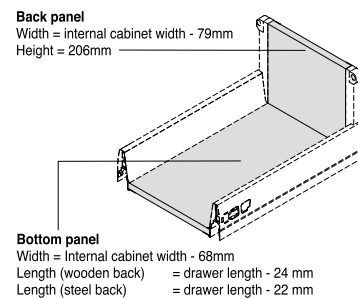

Pre-drilling Dimension of Bottom Panel for Fixing Euro Screws

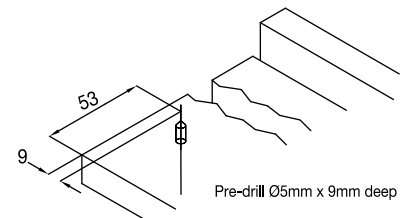

Cutting Dimensions for Front Panel

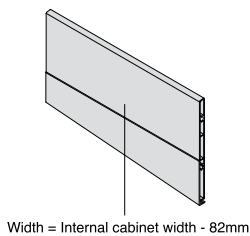

Cutting Dimensions for Front Railing

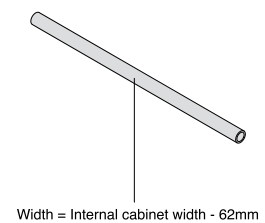



Horn - Triomax Drawer System

TRIOMAX Divider Panel





triomax

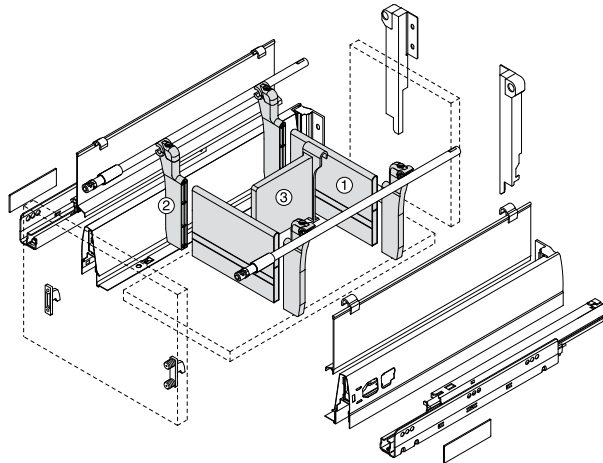

- Available in white & metallic grey
- Roller bearing concealed runners
- Full extension with synchro control
- Steel drawer side 83mm
- Load capacity of 50kg
- Quick assembly
- Flexible 3-dimensional front adjustment
- **Sylent** integrated cushioning system
- Integrated stabilizer



①	Divider Panel	②	Divider Panel Connector	③	Lateral Divider
					
Cabinet Width (16mm Side Panel)			RPC.6100. DG		RLD.6600. DG
400mm	RPD.278				
450mm	RPD.328				
500mm	RPD.378				
550mm	RPD.428				
600mm	RPD.478				
900mm	RPD.778				
1000mm	RPD.878				
1200mm	RPD.1078				

Cutting Dimensions for Divider Panel

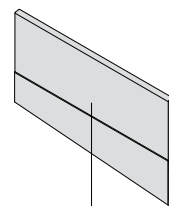

Width = Internal cabinet width - 89mm



TRIOMAX Divider Railing

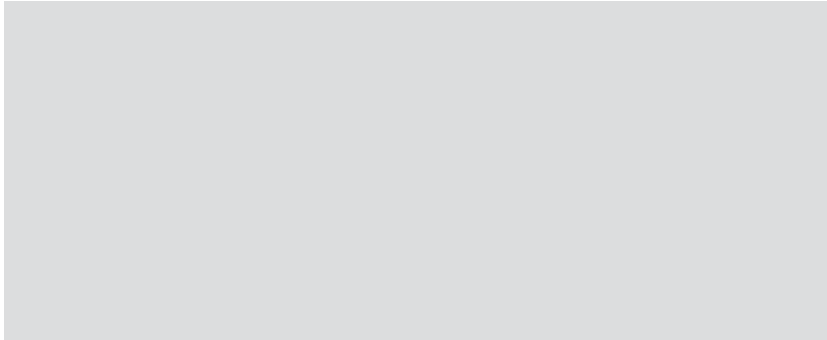

Triomax

- Available in white & metallic grey
- Roller bearing concealed runners
- Full extension with synchro control
- Steel drawer side 83mm
- Load capacity of 50kg
- Quick assembly
- Flexible 3-dimensional front adjustment
- **Sylent** integrated cushioning system
- Integrated stabilizer

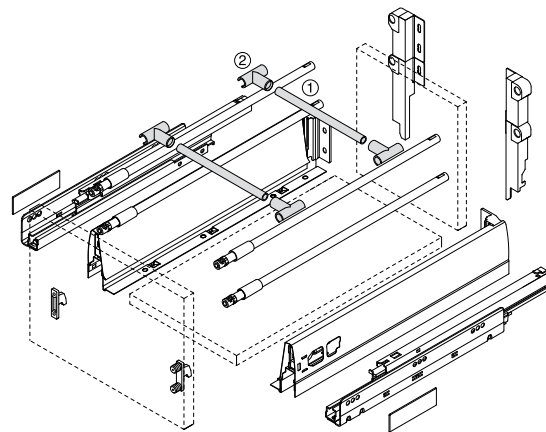

①	Cross Railing	②	Cross Railing Connector
			RRC.7200.DG
	Cabinet Width (16mm side panel)		
	400mm		RRF.309.L
	450mm		RRF.359.L
	500mm		RRF.409.L
	550mm		RRF.459.L
	600mm		RRF.509.L
	900mm		RRF.809.L
	1000mm		RRF.909.L
	1200mm		RRF.1109.L

Cutting Dimensions for Cross Railing

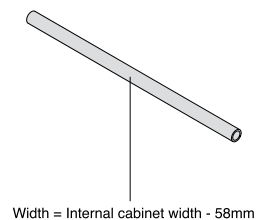

For price list see page C.29 - C.38





Horn - Triomax Drawer System

TRIOMAX Side Extension / Cross Railing

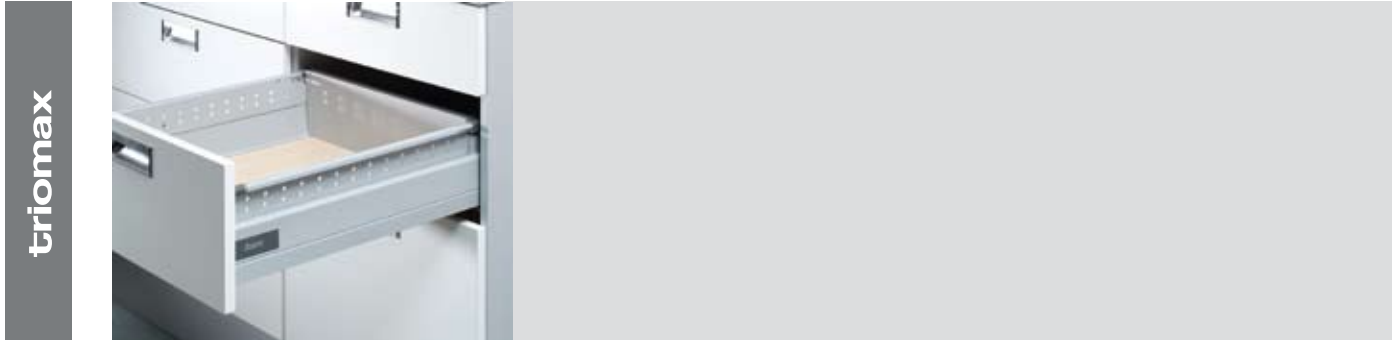

triomax

① Side Extension
- 64mm high

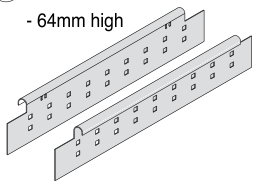

- 128mm high

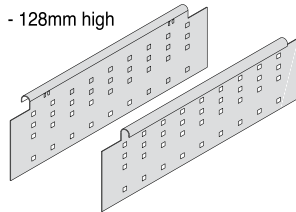

Drawer Length	Article No. 64mm high	128mm high
350mm	RSE.064.350	RSE.128.350
400mm	RSE.064.400	RSE.128.400
450mm	RSE.064.450	RSE.128.450
500mm	RSE.064.500	RSE.128.500
550mm	RSE.064.550	RSE.128.550

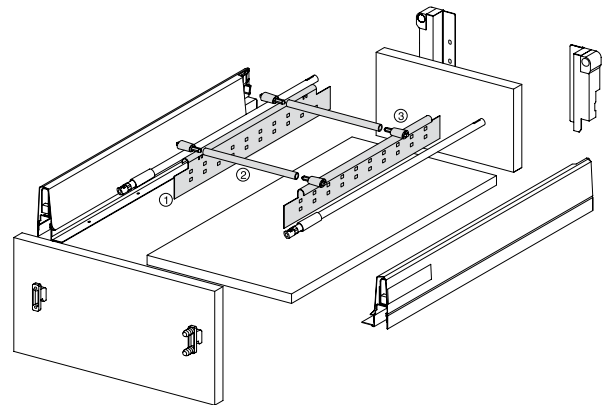

② Side Extension
Cross railing

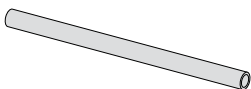

Cabinet width (16mm side panel)	Article No.
400mm	RRF.275.L
450mm	RRF.325.L
500mm	RRF.375.L
550mm	RRF.425.L
600mm	RRF.475.L
900mm	RRF.775.L
1000mm	RRF.875.L
1200mm	RRF.1075.L

③ Cross railing fitting

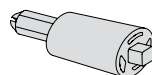

Article No.
RRC.8500

Cutting dimension

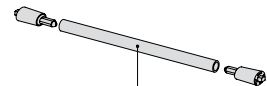

Width = internal cabinet width - 92 mm



Harn - Triomax Drawer System



TRIOMAX Pantry Unit

Space Requirements and Front Installation Dimensions

Cabinet Width - 300 / 400mm

Important Notice:

Minimum one pull-out unit connected to the front must be equipped with a gallery to provide tilt adjustment and to ensure front stability.

It is recommended that all pull-out units, with exception for centre pull-out unit be equipped with Sylent to ensure optimal operation.



Triomax

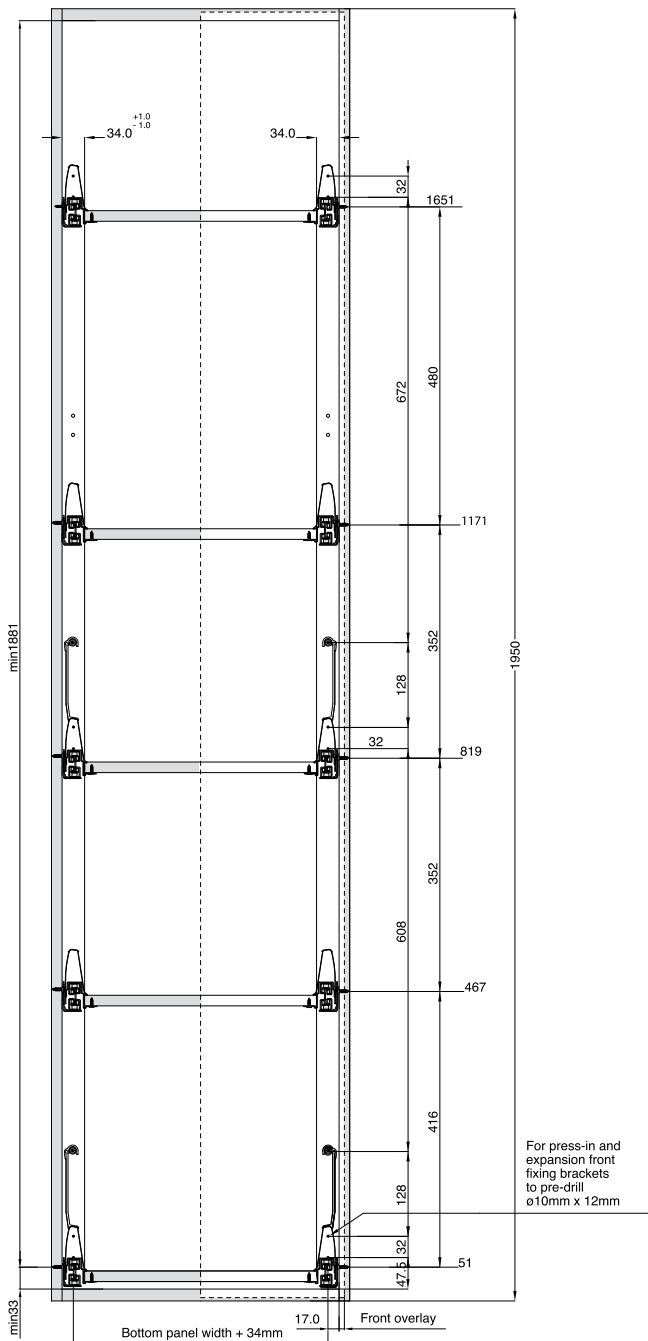

- | | | |
|---|--|---------------|
| 1 | Standard Drawer S connected to front | See page C.5 |
| 2 | Double Railing H Inner Drawer | See page C.15 |
| 3 | Side Extend H Standard Drawer connected to front | See page C.17 |
| 4 | Inner Drawer S | See page C.7 |
| 5 | Side Extend H Standard Drawer connected to front | See page C.17 |

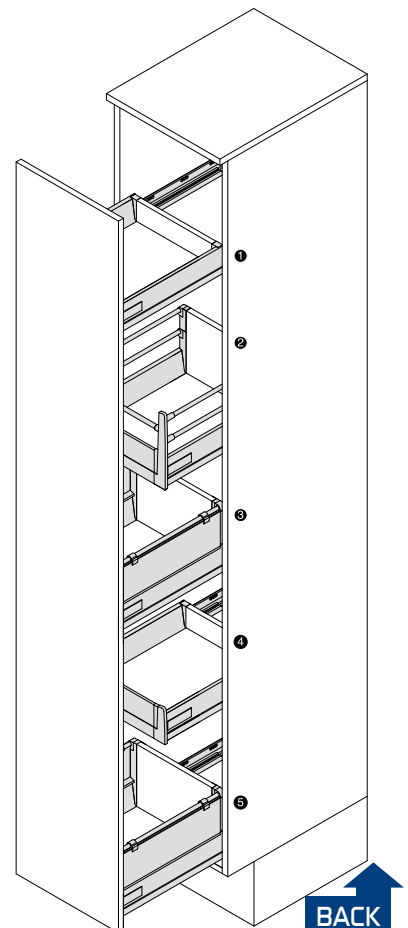



TRIOMAX Filing System Standard Drawer





triomax

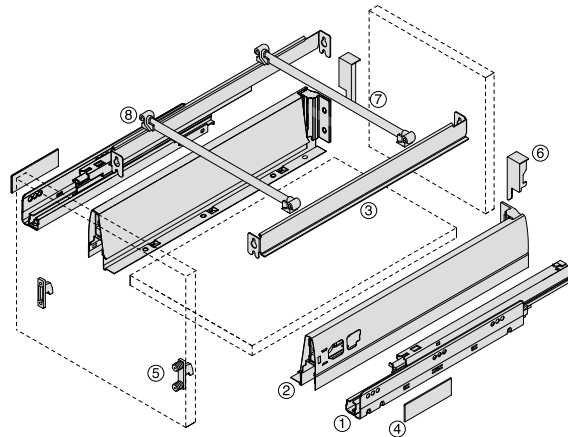

- Available in white & metallic grey
- Roller bearing concealed runners
- Full extension with synchro control
- Steel drawer side 83mm
- Load capacity of 50kg
- Quick assembly
- Flexible 2-dimensional front adjustment
- **Sylent** integrated cushioning system
- Integrated stabilizer

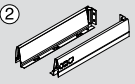
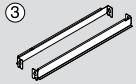
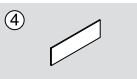
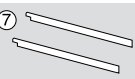

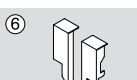
	Carcase Profiles Left / Right : electro galvanised		Drawer Side Left / Right		File Railings Left / Right
Drawer Length					
450mm	TM46.45		TD36.45		RMF.450T
500mm	TM46.50		TD36.50		RMF.500T
550mm	TM46.55		TD36.55		RMF.550T
	Cover Cap-plain RBC.62030. DG		Cross File Rail RMF-C.475		
	Front Fixing Brackets Screw-on RBF.21030 Press-in RBF.22030 Expansion RBF.23030		Cross File Rail Connector RFC.8600		
	Rear Fixing Brackets RBR.76030R RBR.76030L Steel Back N/A				



Harn - Triomax Drawer System

Space Requirements and Front Installation Dimensions

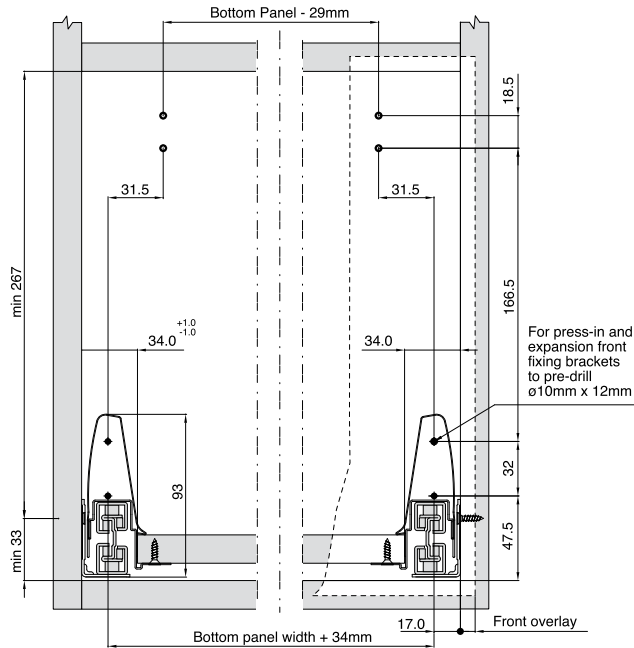

Back Installation Dimensions

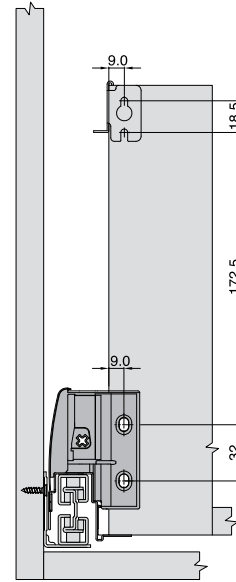

triomax

Cabinet Profile Fixing Positions

Cutting Dimensions for 16mm Chipboard

Drawer Length

450 mm

500 mm

550 mm

Min. internal cabinet depth = drawer length + 3 mm
Actual loss of extension = 0 mm

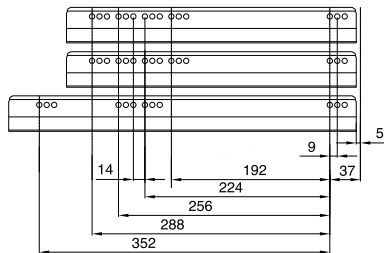

Back panel
Width = internal cabinet width - 79mm
Height = 264mm

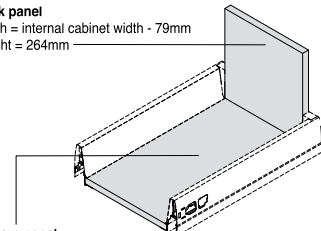

Bottom panel
Width = Internal cabinet width - 68mm
Length (wooden back) = drawer length - 24 mm
Length (steel back) = drawer length - 22 mm

Pre-drilling Dimension of Bottom Panel for Fixing Euro Screws

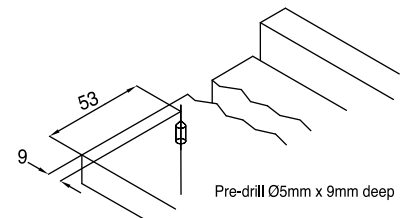

DIN A4 Along Drawer Width

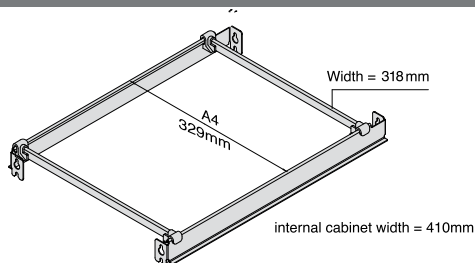

DIN A4 Along Drawer Length

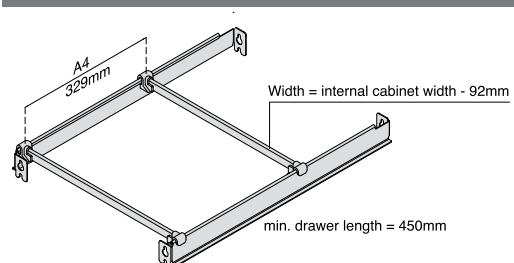



TRIOMAX

Assembly, Removal and Adjustment

triomax

Drawer S Assembly - Wooden Back

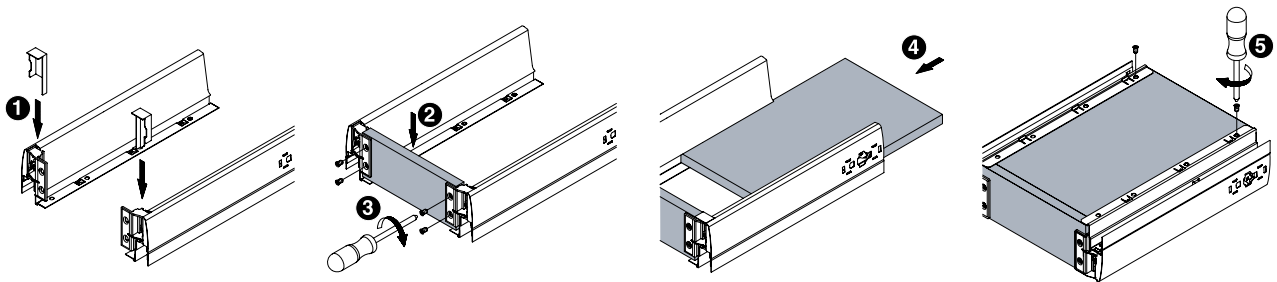

Drawer M, H Assembly - Wooden Back

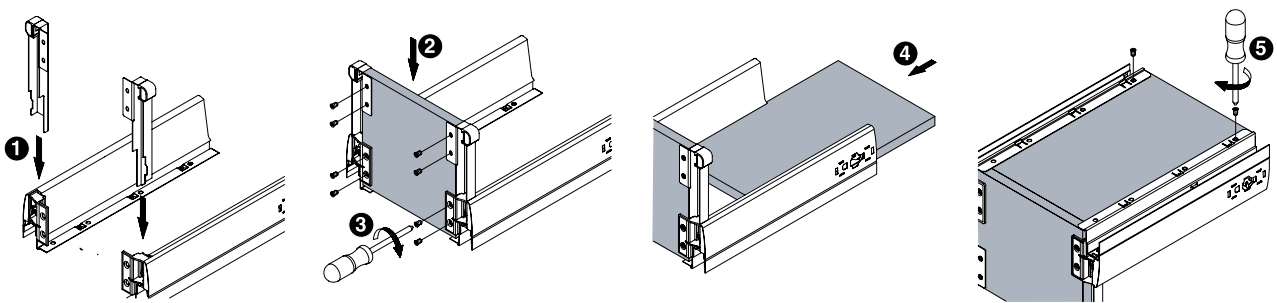

Drawer Insertion

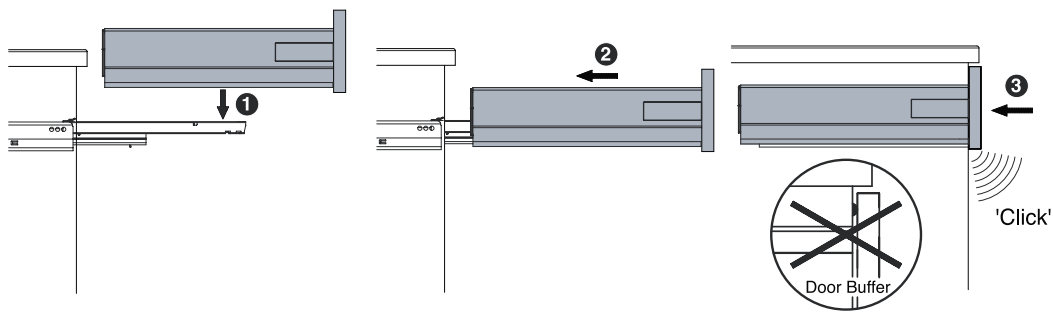

Drawer Removal

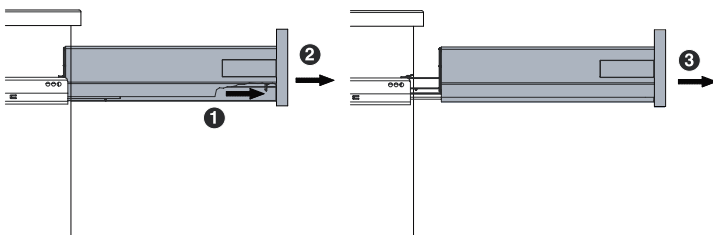



Harn - Triomax Drawer System

TRIOMAX Assembly, Insertion and Removal

triomax

Front Assembly And Removal Front Adjustment

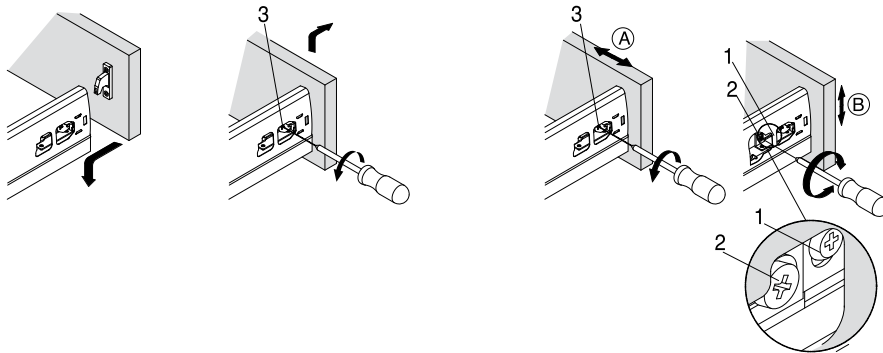

- (A) Side adjustment :**
 Rotate the lever 3 anti-clockwise
 Move front in to required position.
 Adjustment range $\pm 1.5\text{mm}$
 Press down the front panel to lock
- (B) Height adjustment :**
 Loosen screw 1 slightly.
 Adjust eccentric screw 2.
 Adjustment range $\pm 1.8\text{mm}$
 Retighten screw 1.

Railing Assembly And Adjustment

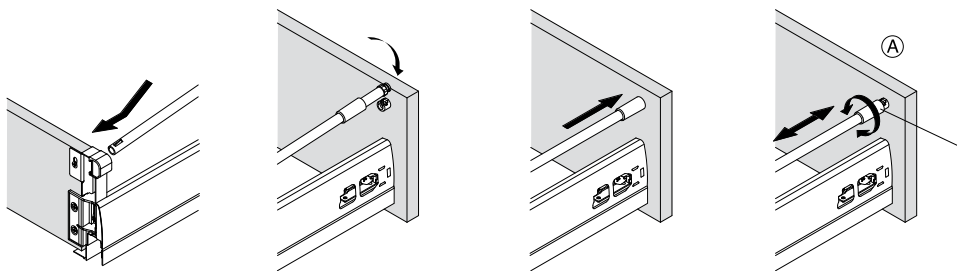

- (A) Tilt adjustment :**
 Pull out the Cover sleeve 1
 slightly and turn it for tilt
 adjustment. Push the cover
 sleeve 1 back after adjustment.

Inner Drawer S Assembly / Removal

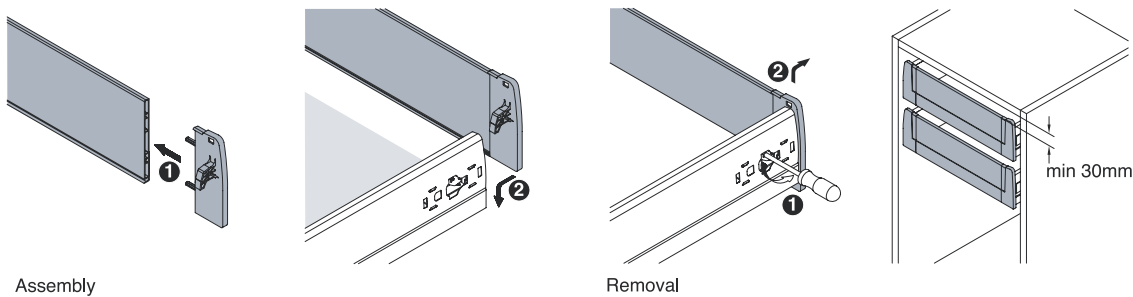

Assembly

Removal

Inner Drawer H Assembly

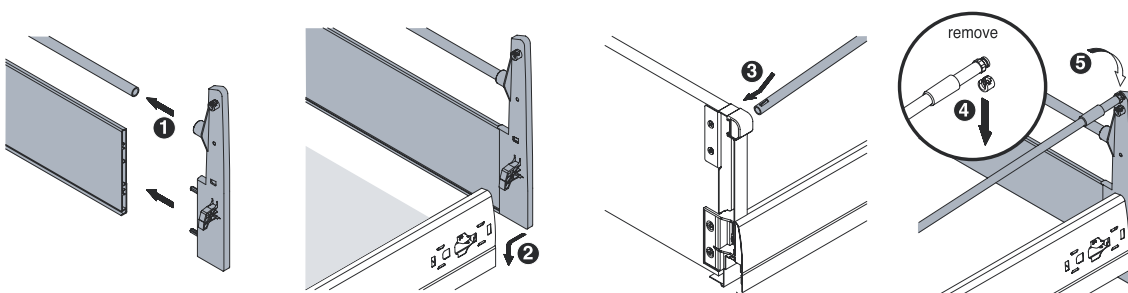



Harn - Triomax Drawer System

TRIOMAX Price List

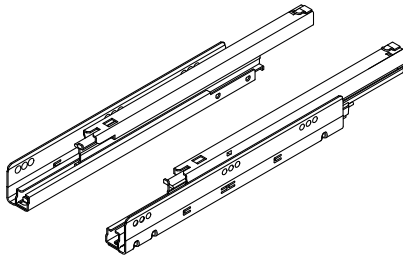

CARCASE PROFILES - SOFT CLOSE

Left & Right

Part No.	Drawer Length	Finish	Price 100	Price 10	Price pr	per
TM46.27	270	EG				pr
TM46.35	350	EG				pr
TM46.40	400	EG				pr
TM46.45	450	EG				pr
TM46.50	500	EG				pr
TM46.55	550	EG				pr

DRAWER SIDE

Left & Right

Part No.	Drawer Length	Finish	Price 100	Price 10	Price pr	per
TD36.27	270	WH				pr
TD36.35	350	WH				pr
TD36.40	400	WH				pr
TD36.45	450	WH				pr
TD36.50	500	WH				pr
TD36.55	550	WH				pr

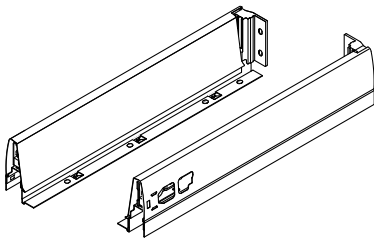

Part No.	Drawer Length	Finish	Price 100	Price 10	Price pr	per
TD36.27	270	GM				pr
TD36.35	350	GM				pr
TD36.40	400	GM				pr
TD36.45	450	GM				pr
TD36.50	500	GM				pr
TD36.55	550	GM				pr



Note: Non soft-close carcass profiles available to order



Harn - Triomax Drawer System





TRIOMAX Price List

COVER CAP

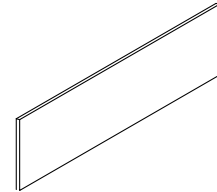
Part No.	Finish	Price 100	Price 10	Price ea	per
RBC.62030	DG				ea



FRONT FIXING BRACKETS

Part No.		Price 100	Price 10	Price ea	per
RBF.21030	Screw-on 				ea
RBF.22030	Press-in 				ea
RBF.23030	Expansion 				ea

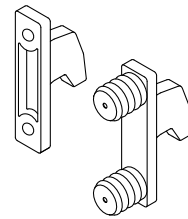

REAR FIXING BRACKETS

Part No.	Finish	Price 100	Price 10	Price ea	per
RBR.76030R	Right	WH, GM			ea
RBR.76030L	Left	WH, GM			ea

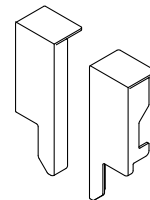

Part No.	Finish	Price 100	Price 10	Price ea	per
RBR.77030R	Right	WH, GM			ea
RBR.77030L	Left	WH, GM			ea

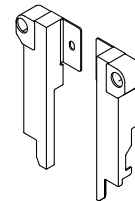

Part No.	Finish	Price 100	Price 10	Price ea	per
RBR.78030R	Right	WH, GM			ea
RBR.78030L	Left	WH, GM			ea

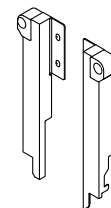

Part No.	Finish	Price 100	Price 10	Price ea	per
RBR.73030R	Right	WH, GM			ea
RBR.73030L	Left	WH, GM			ea

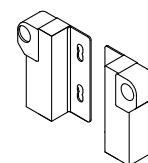



Harn - Triomax Drawer System

TRIOMAX Price List

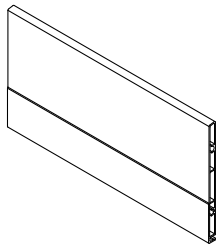

INNER DRAWER FRONT PANEL

Part No.	Cabinet Width (16mm Side Panel)	Finish	Price 100	Price 10	Price ea	per
RPF860.285	400	WH, GM				ea
RPF860.335	450	WH, GM				ea
RPF860.385	500	WH, GM				ea
RPF860.435	550	WH, GM				ea
RPF860.485	600	WH, GM				ea
RPF860.785	900	WH, GM				ea
RPF860.885	1000	WH, GM				ea
RPF860.1085	1200	WH, GM				ea

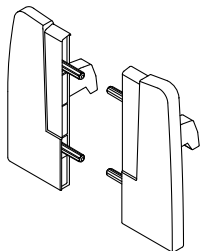

INNER DRAWER FRONT FIXING BRACKETS

Drawer S

Part No.		Finish	Price 100	Price 10	Price ea	per
RBF.56030R	Right	DG				ea
RBF.56030L	Left	DG				ea

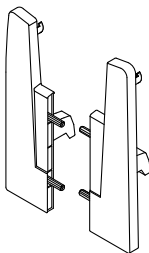

Drawer M

Part No.		Finish	Price 100	Price 10	Price ea	per
RBF.57030R	Right	DG				ea
RBF.57030L	Left	DG				ea

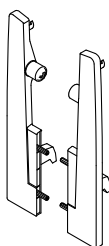

Drawer H

Part No.		Finish	Price 100	Price 10	Price ea	per
RBF.58030R	Right	DG				ea
RBF.58030L	Left	DG				ea





Harn - Triomax Drawer System

TRIOMAX Price List

INNER DRAWER FRONT RAILING

Part No.	Cabinet Width (16mm Side Panel)	Finish	Price 100	Price 10	Price ea	per
RRF.305	400	WH, GM				ea
RRF.355	450	WH, GM				ea
RRF.405	500	WH, GM				ea
RRF.455	550	WH, GM				ea
RRF.505	600	WH, GM				ea
RRF.805	900	WH, GM				ea
RRF.905	1000	WH, GM				ea
RRF.1105	1200	WH, GM				ea

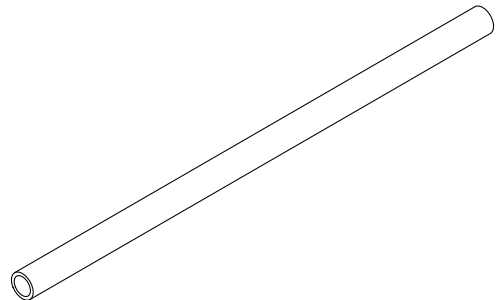

RAILING SET

Screw-on



Part No.	Drawer Length	Finish	Price 100	Price 10	Price pr	per pr
RRAS.321	350	WH, GM				pr
RRAS.371	400	WH, GM				pr
RRAS.421	450	WH, GM				pr
RRAS.471	500	WH, GM				pr
RRAS.521	550	WH, GM				pr

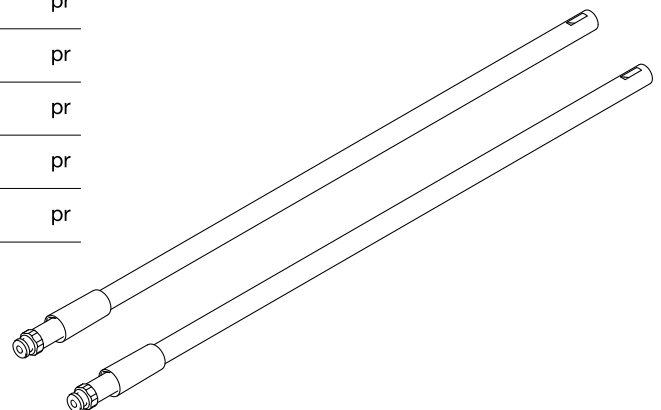

Expansion



Part No.	Drawer Length	Finish	Price 100	Price 10	Price pr	per pr
RRAS-E.321	350	WH, GM				pr
RRAS-E.371	400	WH, GM				pr
RRAS-E.421	450	WH, GM				pr
RRAS-E.471	500	WH, GM				pr
RRAS-E.521	550	WH, GM				pr





TRIOMAX Price List

CROSS RAILING

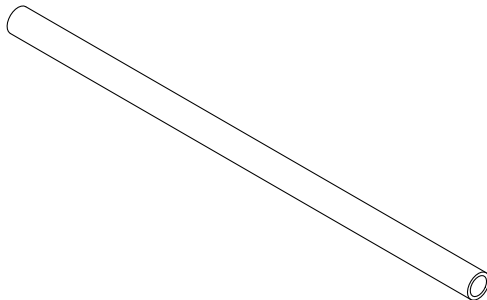

Part No.	Cabinet Width (16mm Side Panel)	Finish	Price 100	Price 10	Price ea	per
RRF.309.L	400	WH, GM				ea
RRF.359.L	450	WH, GM				ea
RRF.409.L	500	WH, GM				ea
RRF.459.L	550	WH, GM				ea
RRF.509.L	600	WH, GM				ea
RRF.809.L	900	WH, GM				ea
RRF.909.L	1000	WH, GM				ea
RRF.1109.L	1200	WH, GM				ea

CROSS RAILING CONNECTORS

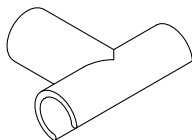

Part No.	Finish	Price 100	Price 10	Price ea	per
RRC.7200	DG				ea





Harn - Triomax Drawer System

TRIOMAX Price List

SIDE PANEL

Part No.	Drawer Length	Finish	Price 100	Price 10	Price ea	per
RSE-H.321	350	WH				ea
RSE-H.371	400	WH				ea
RSE-H.421	450	WH				ea
RSE-H.471	500	WH				ea
RSE-H.521	550	WH				ea

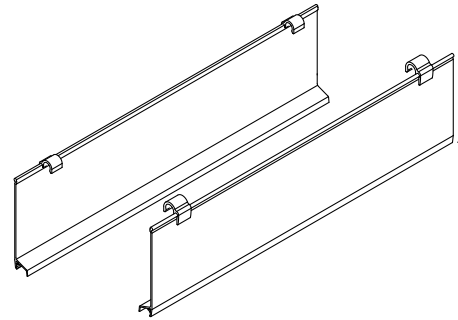

Part No.	Drawer Length	Finish	Price 100	Price 10	Price ea	per
RSE-H.321	350	GM				ea
RSE-H.371	400	GM				ea
RSE-H.421	450	GM				ea
RSE-H.471	500	GM				ea
RSE-H.521	550	GM				ea

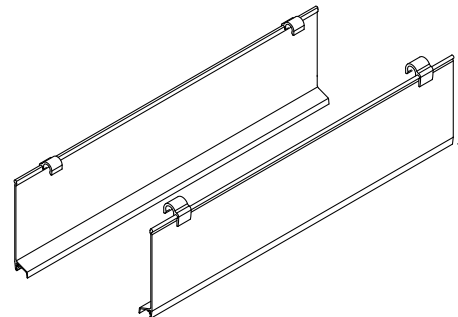



Horn - Triomax Drawer System

TRIOMAX Price List

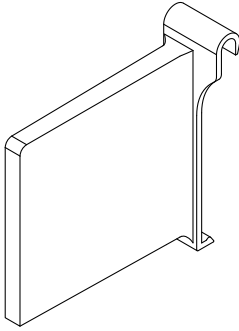

LATERAL DIVIDER

Part No.	Finish	Price 100	Price 10	Price ea	per
RLD.6600	DG				ea

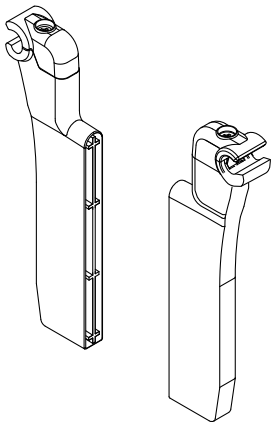

DIVIDER PANEL CONNECTOR

Part No.	Finish	Price 100	Price 10	Price ea	per
RPC.6100	DG				ea

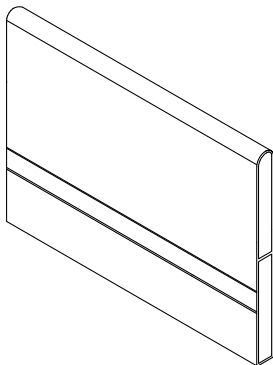

DIVIDER PANEL

Part No.	Cabinet Width (16mm Side Panel)	Finish	Price 100	Price 10	Price ea	per
RPD.278	400	WH, GM				ea
RPD.328	450	WH, GM				ea
RPD.378	500	WH, GM				ea
RPD.428	550	WH, GM				ea
RPD.478	600	WH, GM				ea
RPD.778	900	WH, GM				ea
RPD.878	1000	WH, GM				ea
RPD.1078	1200	WH, GM				ea





Harn - Triomax Drawer System

TRIOMAX Price List

FILE RAILINGS

Left & Right

Part No.	Drawer Length	Finish	Price 100	Price 10	Price pr	per
RMF.450T	450	WH, GM				pr
RMF.500T	500	WH, GM				pr

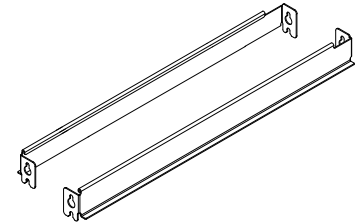

FILE CROSS RAIL

Part No.	Finish	Price 100	Price 10	Price ea	per
RMF-C.475	WH, GM				ea

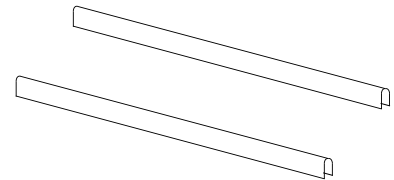

FILE CROSS RAIL CONNECTOR

Part No.	Finish	Price 100	Price 10	Price ea	per
RFC.8600	WH				ea

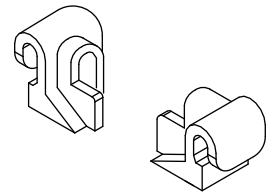

SIDE EXTENSION CROSS RAILING

Part No.	Cabinet Width (16mm Side Panel)	Finish	Price 100	Price 10	Price ea	per
RRF.275.L	400	WH, GM				ea
RRF.325.L	450	WH, GM				ea
RRF.375.L	500	WH, GM				ea
RRF.425.L	550	WH, GM				ea
RRF.475.L	600	WH, GM				ea
RRF.775.L	900	WH, GM				ea
RRF.875.L	1000	WH, GM				ea
RRF.1075.L	1200	WH, GM				ea

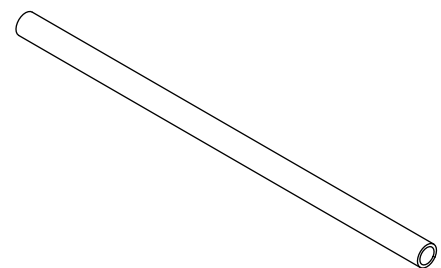

SIDE EXTENSION CROSS RAILING FITTING

Part No.	Finish	Price 100	Price 10	Price ea	per
RRC.8500	DG				ea

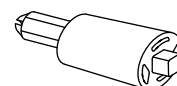



TRIOMAX Price List

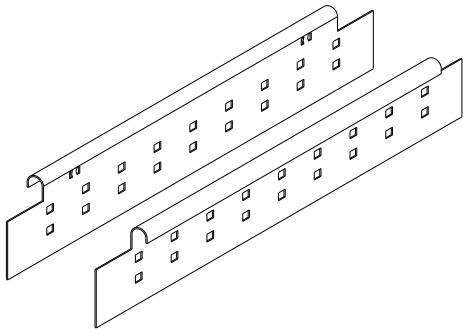

SIDE EXTENSION

64mm High
Drawer M

Part No.	Drawer Length	Finish	Price 100	Price 10	Price ea	per
RSE.064.350	350	WH, GM				ea
RSE.064.400	400	WH, GM				ea
RSE.064.450	450	WH, GM				ea
RSE.064.500	500	WH, GM				ea
RSE.064.550	550	WH, GM				ea

Note: Sold per each - NOT PAIRS

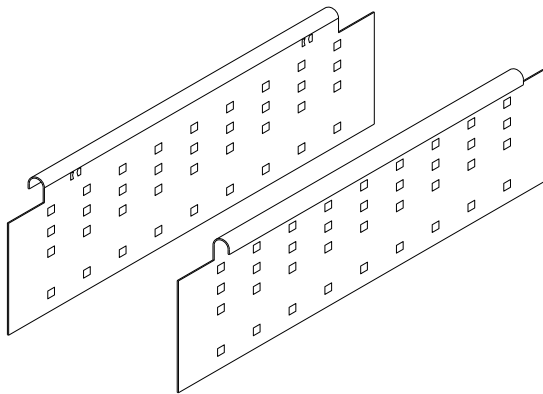

128mm High
Drawer H

Part No.	Drawer Length	Finish	Price 100	Price 10	Price ea	per
RSE.128.350	350	WH, GM				ea
RSE.128.400	400	WH, GM				ea
RSE.128.450	450	WH, GM				ea
RSE.128.500	500	WH, GM				ea
RSE.128.550	550	WH, GM				ea

Note: Sold per each - NOT PAIRS

STEEL BACK - STANDARD

Drawer S

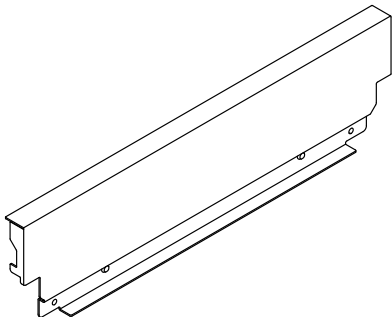

Part No.	Cabinet Width (16mm Side Panel)	Finish	Price 100	Price 10	Price ea	per
RSBT3.333	400	WH, GM				ea
RSBT3.383	450	WH, GM				ea
RSBT3.433	500	WH, GM				ea
RSBT3.483	550	WH, GM				ea
RSBT3.533	600	WH, GM				ea
RSBT3.833	900	WH, GM				ea
RSBT3.933	1000	WH, GM				ea
RSBT3.1133	1200	WH, GM				ea





TRIOMAX Price List

STEEL BACK RAILING SYSTEM M

Drawer M

Part No.	Cabinet Width (16mm Side Panel)	Finish	Price 100	Price 10	Price ea	per
RSBT3R.333	400	WH, GM				ea
RSBT3R.383	450	WH, GM				ea
RSBT3R.433	500	WH, GM				ea
RSBT3R.483	550	WH, GM				ea
RSBT3R.533	600	WH, GM				ea
RSBT3R.833	900	WH, GM				ea
RSBT3R.933	1000	WH, GM				ea
RSBT3R.1133	1200	WH, GM				ea

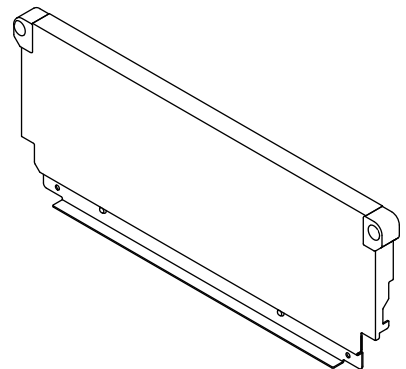

STEEL BACK RAILING SYSTEM H

Drawer H

Part No.	Cabinet Width (16mm Side Panel)	Finish	Price 100	Price 10	Price ea	per
RSBT3HR.333	400	WH, GM				ea
RSBT3HR.383	450	WH, GM				ea
RSBT3HR.433	500	WH, GM				ea
RSBT3HR.483	550	WH, GM				ea
RSBT3HR.533	600	WH, GM				ea
RSBT3HR.833	900	WH, GM				ea
RSBT3HR.933	1000	WH, GM				ea
RSBT3HR.1133	1200	WH, GM				ea

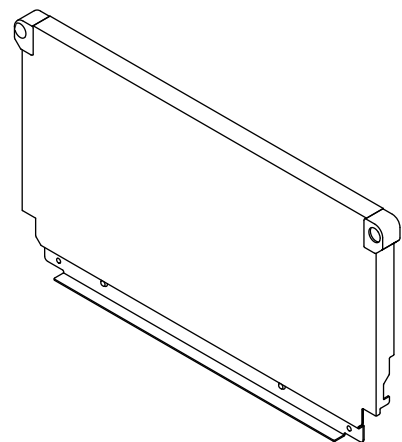



harn **Impaz** **Drawer System**

- Load capacity 40kg
- Flexible 2-dimensional front adjustment
- Smooth rolling mechanism
- Epoxy coated



Harn - Impaz Drawer System



IMPAZ CONTENTS

	Pg
4020/4021 Steel Drawer	C.41
4320/4321 Steel Drawer	C.43
4620/4621 Steel Drawer	C.45
Full Extension Steel Drawer	C.47
Full Extension Kit	C.48
Front Fixing Brackets	C.49
Cover Caps	C.49
Internal Drawer Front Fixing Brackets	C.50
Railing Systems	C.51
Filing System	C.53
Side Extensions	C.55
Steel Brackets	C.56
Marking Devices	C.63
Bracket Insertion Tool	C.65
Drilling Jig / Technical Manual	C.66



IMPAZ 4020/4021

Steel Drawer - Single Extension - 85mm High

- Single extension
- Steel drawer side panels 85mm
- Epoxy coated
- Load capacity of 30kg
- Self closing feature
- Flexible 2-dimensional front adjustment
- Smooth rolling mechanism
- Double out-stop safety feature
- Locked-in position when extended

One set IMPAZ Drawer consists of:

- ① Cabinet members L + R
- ② Drawer sides L + R

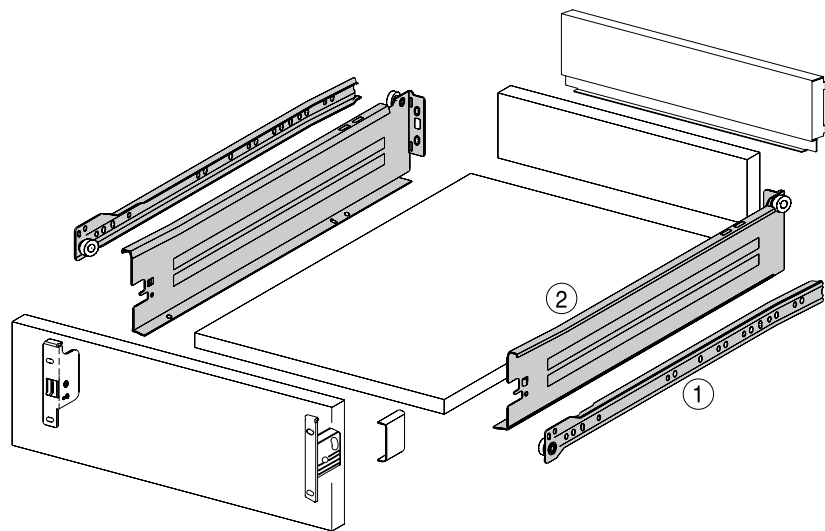

IMPAZ DRAWER - PLUG IN BASE - WITH PINS

85mm High

Part No.	Drawer Length	Finish	Price 100	Price 10	Price set	per
4021/25	250	WH				set
4021/27	270	WH				set
4021/35	350	WH				set
4021/40	400	WH				set
4021/45	450	WH				set
4021/50	500	WH				set
4021/55	550	WH				set

PLUG IN BASE; (Standard)

- Each drawer side has 2 pins
- Requires 4 x 5mm ø holes in base
- Ensures drawer is made square
- Faster assembly time
- Drilling jig available (pg C.66)

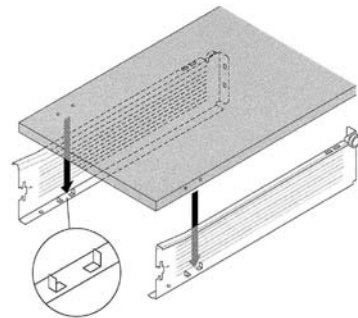

IMPAZ DRAWER - SCREW ON BASE - NO PINS

85mm High

Part No.	Drawer Length	Finish	Price 100	Price 10	Price set	per
4020/27	270	WH				set
4020/35	350	WH				set
4020/40	400	WH				set
4020/45	450	WH				set
4020/50	500	WH				set
4020/55	550	WH				set





HARN - Impaz Drawer System

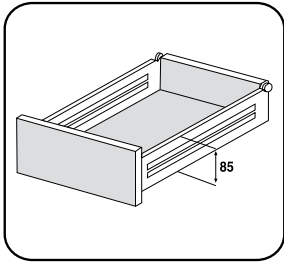

Front installation dimensions

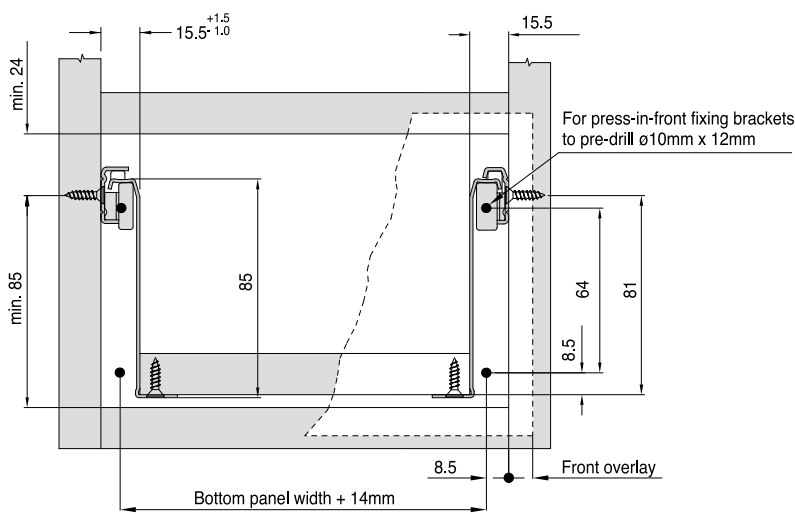

Back installation dimensions

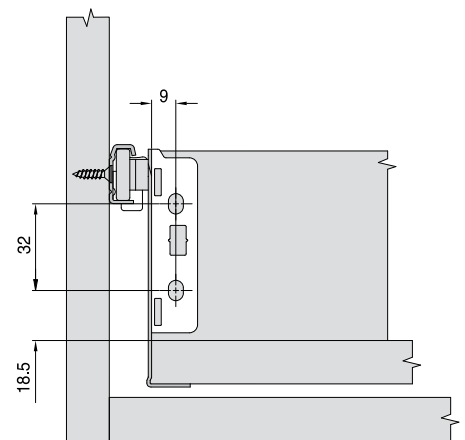

Cabinet profile fixing positions

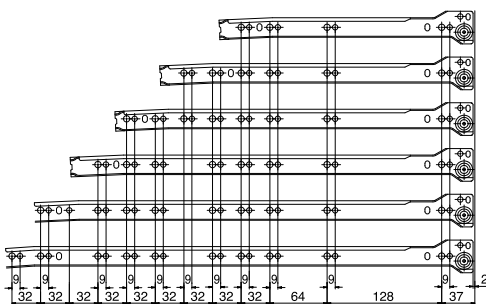

Drawer length	Min. internal cabinet depth	Loss of extension
270mm	273mm	85mm
350mm	353mm	85mm
400mm	403mm	85mm
450mm	453mm	95mm
500mm	503mm	102mm
550mm	553mm	110mm

Drilling pattern for cabinet member

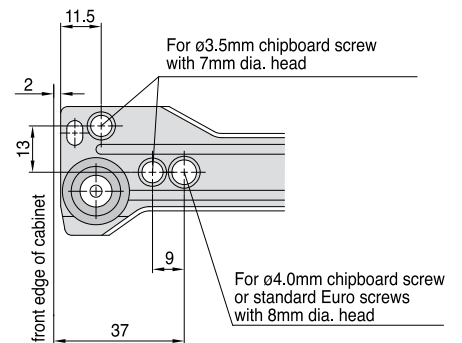

Drilling dimension of bottom panel for plug-in

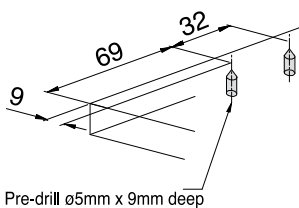

Cutting dimensions for 16mm chipboard

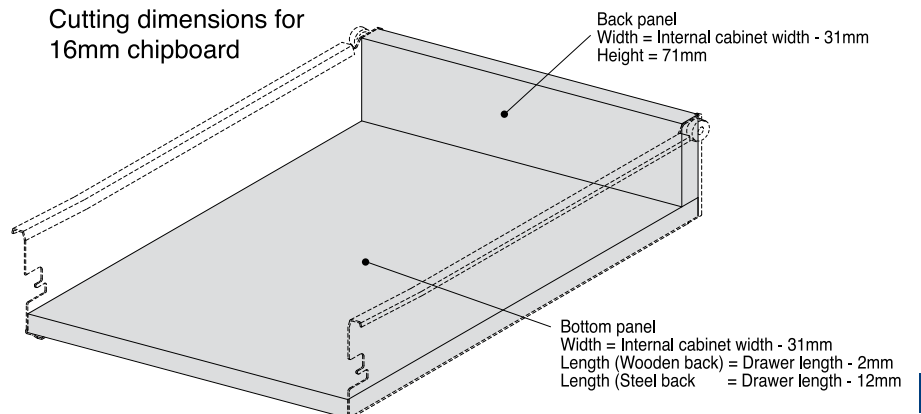



IMPAZ 4320/4321

Steel Drawer - Single Extension - 117mm High

- Single extension
- Steel drawer side panels 117mm
- Epoxy coated
- Load capacity of 30kg
- Self closing feature
- Flexible 2-dimensional front adjustment
- Smooth rolling mechanism
- Double out-stop safety feature
- Locked-in position when extended

One set IMPAZ Drawer consists of:

- ① Cabinet members L + R
- ② Drawer sides L + R

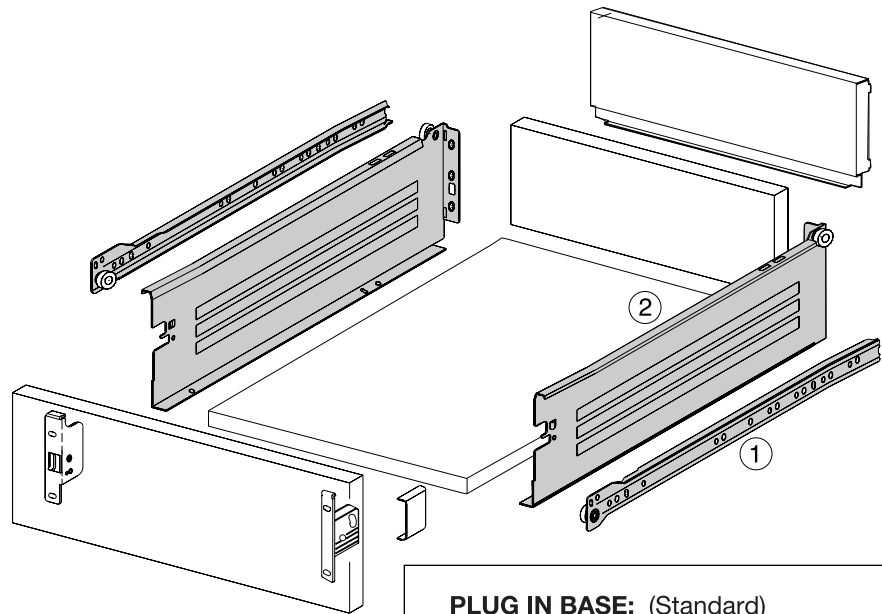

IMPAZ DRAWER - PLUG IN BASE - WITH PINS

117mm High

Part No.	Drawer Length	Finish	Price 100	Price 10	Price set	per set
4321/25	250	WH				set
4321/35	350	WH				set
4321/40	400	WH				set
4321/45	450	WH				set
4321/50	500	WH				set
4321/55	550	WH				set

PLUG IN BASE; (Standard)

- Each drawer side has 2 pins
- Requires 4 x 5mm ø Holes in base
- Ensures drawer is made square
- Faster assembly time
- Drilling jig available (pg C.66)

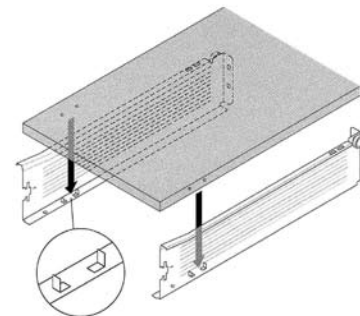

IMPAZ DRAWER - SCREW ON BASE - NO PINS

117mm High

Part No.	Drawer Length	Finish	Price 100	Price 10	Price set	per set
4320/35	350	WH				set
4320/40	400	WH				set
4320/45	450	WH				set
4320/50	500	WH				set
4320/55	550	WH				set





HARN - Impaz Drawer System

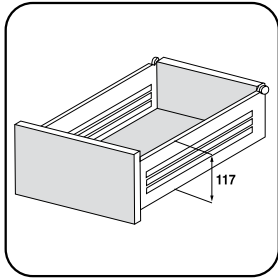

Front installation dimensions

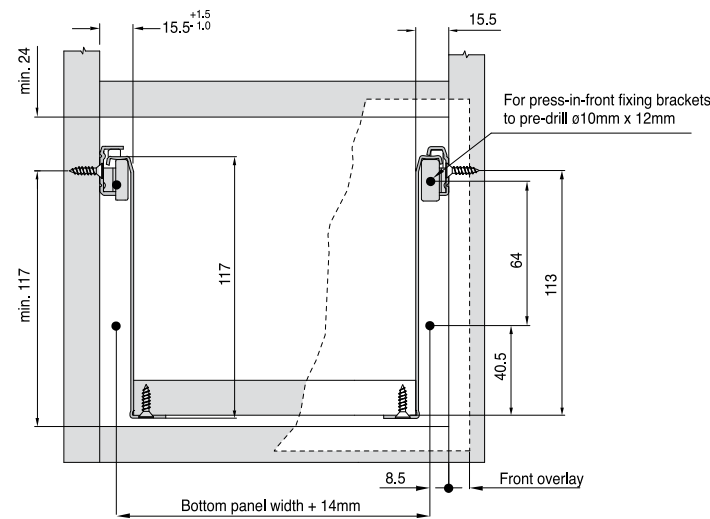

Back installation dimensions

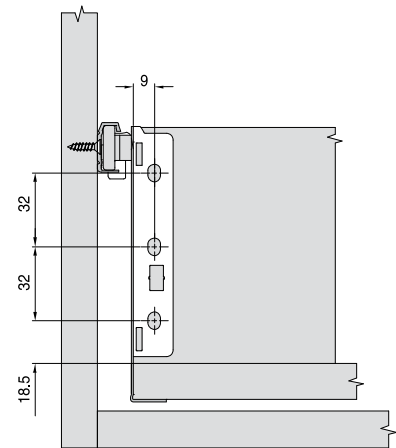

Cabinet profile fixing positions

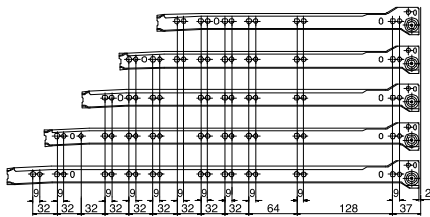

Drawer length	Min. internal cabinet depth	Loss of extension
350mm	353mm	85mm
400mm	403mm	85mm
450mm	453mm	95mm
500mm	503mm	102mm
550mm	553mm	110mm

Drilling pattern for cabinet member

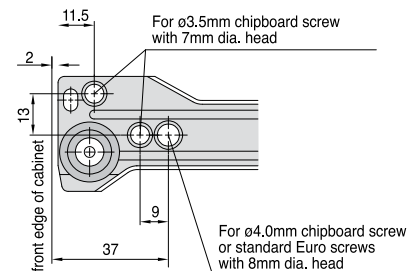

Drilling dimension of bottom panel for plug-in

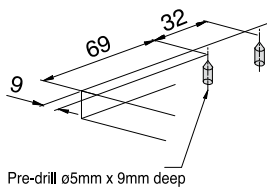

Cutting dimensions for 16mm chipboard

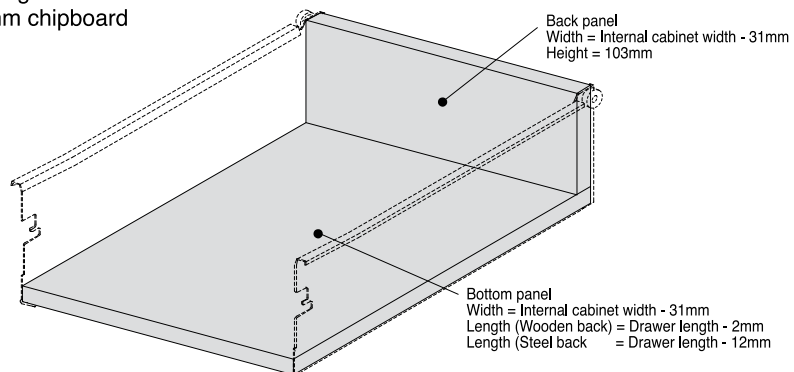



IMPAZ 4620/4621

Steel Drawer - Single Extension - 149mm High

- Single extension
- Steel drawer side panels 149mm
- Epoxy coated
- Load capacity of 30kg
- Self closing feature
- Flexible 2-dimensional front adjustment
- Smooth rolling mechanism
- Double out-stop safety feature
- Locked-in position when extended

One set IMPAZ Drawer consists of:

- ① Cabinet members L + R
- ② Drawer sides L + R

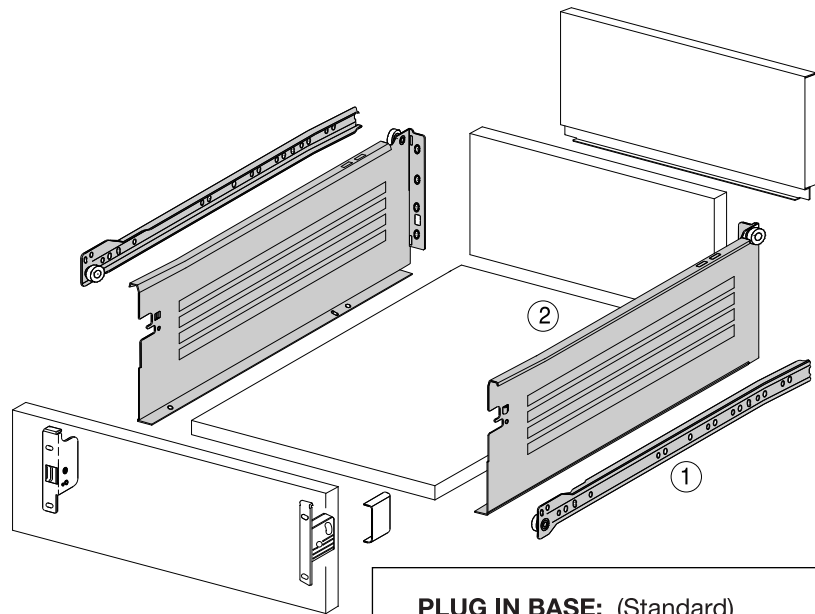

IMPAZ DRAWER - PLUG IN BASE - WITH PINS

149mm High

Part No.	Drawer Length	Finish	Price 100	Price 10	Price set	per
4621/35	350	WH				set
4621/40	400	WH				set
4621/45	450	WH				set
4621/50	500	WH				set
4621/55	550	WH				set

PLUG IN BASE; (Standard)

- Each drawer side has 2 pins
- Requires 4 x 5mm ø holes in base
- Ensures drawer is made square
- Faster assembly time
- Drilling jig available (pg C.66)

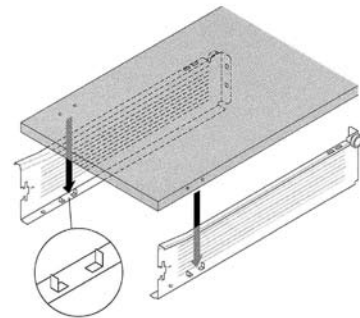

IMPAZ DRAWER - SCREW ON BASE - NO PINS

149mm High

Part No.	Drawer Length	Finish	Price 100	Price 10	Price set	per
4620/35	350	WH				set
4620/40	400	WH				set
4620/45	450	WH				set
4620/50	500	WH				set
4620/55	550	WH				set





HARN - Impaz Drawer System

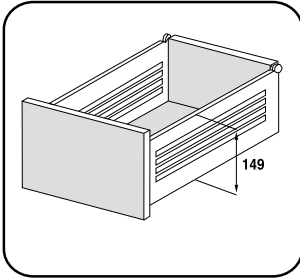

Front installation dimensions

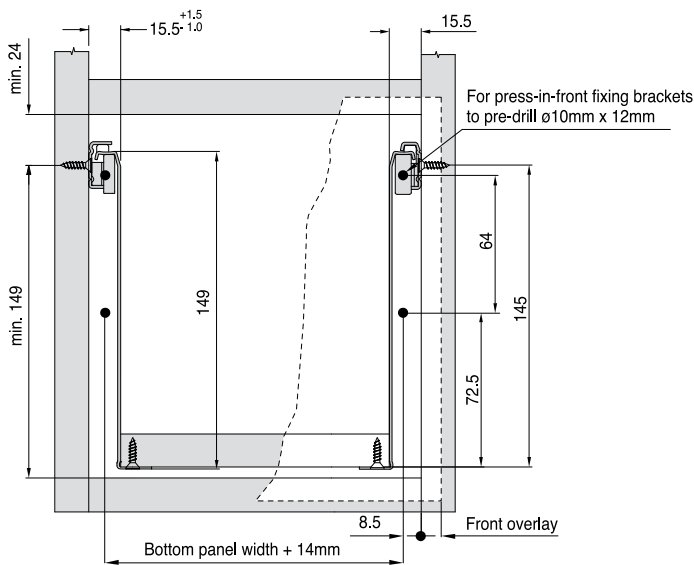

Back installation dimensions

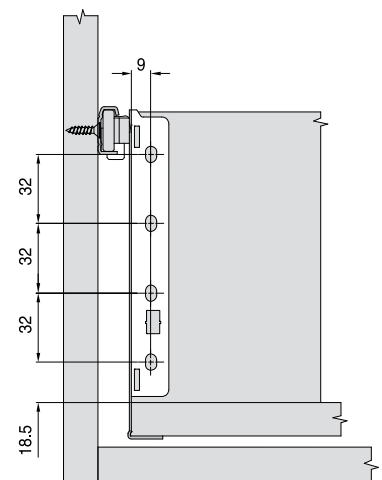

Cabinet profile fixing positions

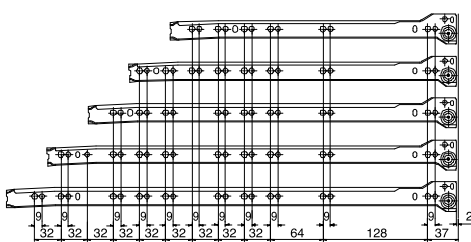

Drawer length	Min. internal cabinet depth	Loss of extension
350mm	353mm	85mm
400mm	403mm	85mm
450mm	453mm	95mm
500mm	503mm	102mm
550mm	553mm	110mm

Drilling pattern for cabinet member

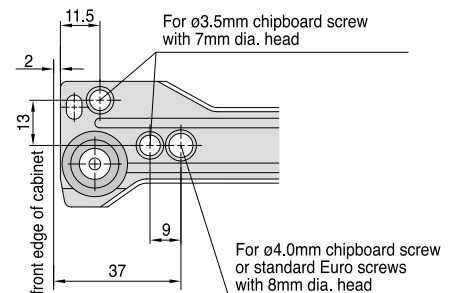

Drilling dimension of bottom panel for plug-in

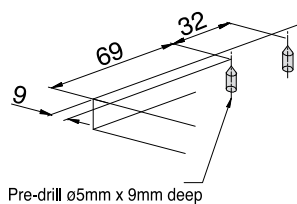

Cutting dimensions for 16mm chipboard

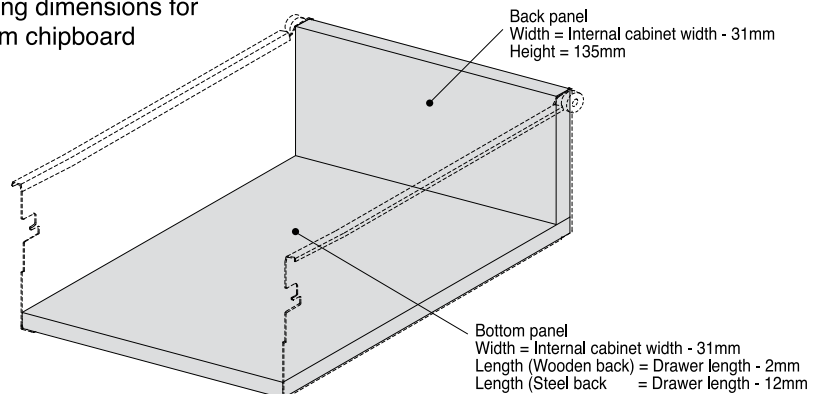



HARN - Impaz Drawer System

IMPAZ

Steel Drawer - Full Extension

- Full extension
- Steel drawer side panels 85mm / 117mm / 149mm
- Epoxy coated
- Load capacity of 40kg
- Self closing feature
- Flexible 2-dimensional front adjustment
- Smooth rolling mechanism
- Double out-stop safety feature
- Locked-in position when extended

One set IMPAZ Drawer consists of:

- ① Cabinet members and Centre Profile L + R
- ② Drawer sides L + R

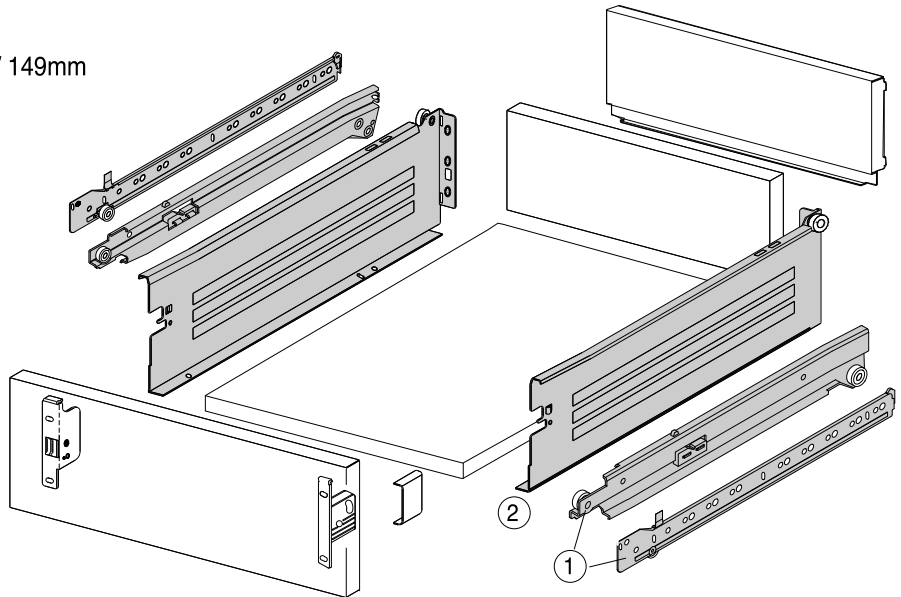

FULL EXTENSION IMPAZ DRAWER - PLUG IN BASE - WITH PINS

Part No.	Drawer Length x Height	Finish	Price 100	Price 10	Price set	per
5021/45	450 x 85	WH				set
5021/50	500 x 85	WH				set
5021/55	550 x 85	WH				set
5321/45	450 x 117	WH				set
5321/50	500 x 117	WH				set
5321/55	550 x 117	WH				set
5621/45	450 x 149	WH				set
5621/50	500 x 149	WH				set
5621/55	550 x 149	WH				set

PLUG IN BASE; (Standard)

- Each drawer side has 2 pins
- Requires 4 x 5mm \varnothing holes in base
- Ensures drawer is made square
- Faster assembly time
- Drilling jig available (pg C.66)

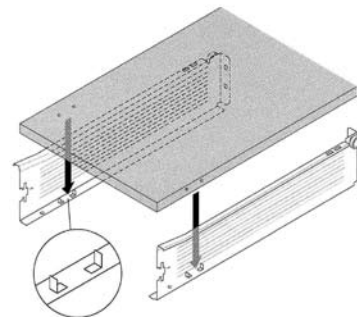

Cabinet profile fixing positions

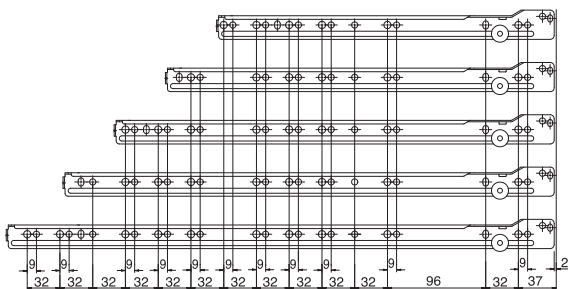

Drawer length	Min. internal cabinet depth	Over extension
350mm	358mm	13mm
400mm	408mm	13mm
450mm	458mm	13mm
500mm	508mm	13mm
550mm	558mm	13mm

Drilling pattern for cabinet member

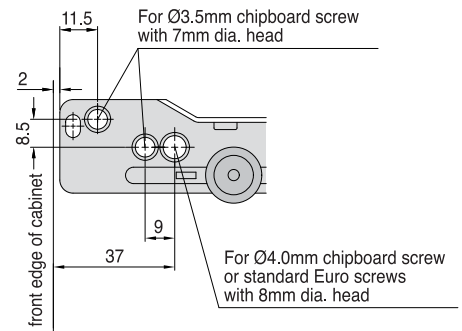



HARN - Impaz Drawer System

IMPAZ

Full Extension Kit

- Quick and easy installation
- Interchangeability for IMPAZ 4020, 4320 & 4620
single extension to full extension
- **Load capacity of 40kg**
- Epoxy coated
- Smooth rolling mechanism
- Self closing feature
- Double out-stop safety features
- Elastic shock absorbers to minimize noise level

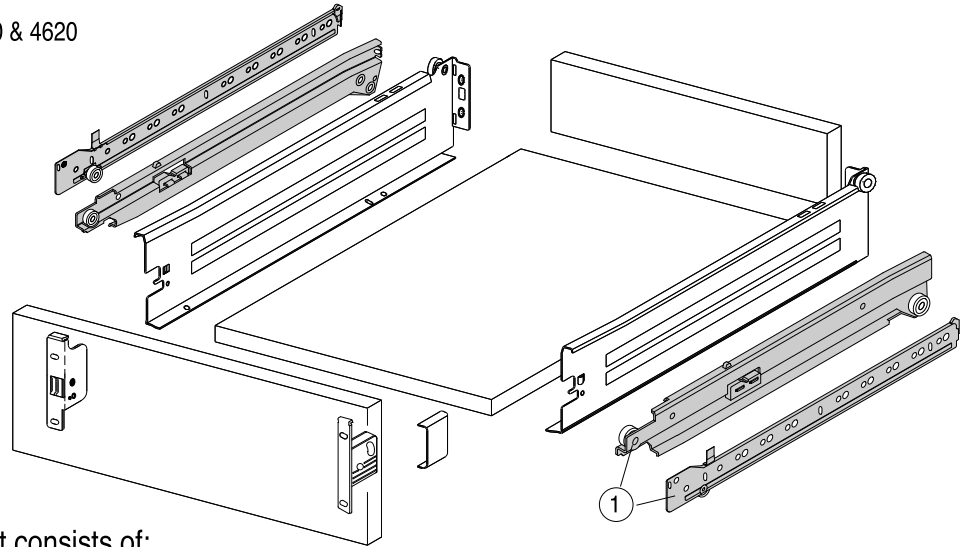

One set IMPAZ Full Extension Kit consists of:

- ① Cabinet members and Centre Profile L + R

FULL EXTENSION KIT FOR IMPAZ DRAWER

Part No.	Drawer Length	Finish	Price 100	Price 10	Price set	per
5000/35	350	WH				set
5000/40	400	WH				set
5000/45	450	WH				set
5000/50	500	WH				set
5000/55	550	WH				set

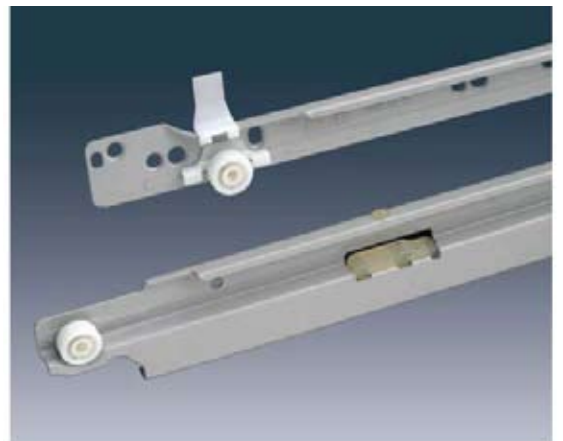



IMPAZ Front Fixing Brackets & Covers

SCREW ON BRACKETS - STANDARD

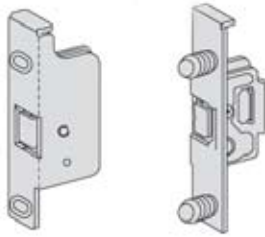

Part No.		Price 100	Price 10	Price ea	per
RBF11040 RH	Screw fix - Right				ea
RBF11040 LH	Screw fix - Left				ea
RBF12040 RH	Press in - Right				ea
RBF12040 LH	Press in - Left				ea
RBF13040 RH	Expansion - Right				ea
RBF13040 LH	Expansion - Left				ea

SCREW ON BRACKETS - PREMIUM

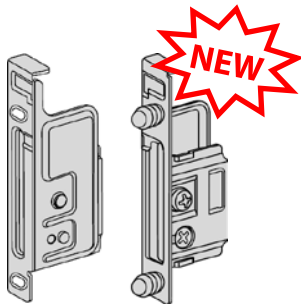

Part No.		Price 100	Price 10	Price ea	per
RBF11240 RH	Screw fix - Right				ea
RBF11240 LH	Screw fix - Left				ea
RBF12240 RH	Press in - Right				ea
RBF12240 LH	Press in - Left				ea
RBF13240 RH	Expansion - Right				ea
RBF13240 LH	Expansion - Left				ea

CLIP-ON BRACKETS

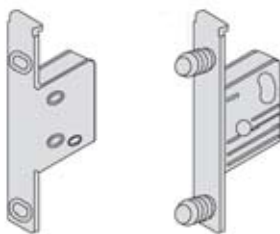

Part No.		Price 100	Price 10	Price ea	per
RBF16040 RH	Screw fix - Right				ea
RBF16040 LH	Screw fix - Left				ea
RBF17040 RH	Press in - Right				ea
RBF17040 LH	Press in - Left				ea
RBF18040 RH	Expansion - Right				ea
RBF18040 LH	Expansion - Left				ea

COVER CAPS

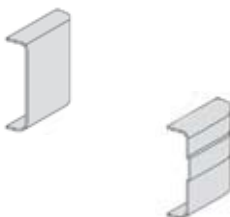

Part No.		Finish	Price 100	Price 10	Price ea	per
RBC61040	Suits screw on bracket	WH				ea
RBC66040 RH	Right - suits clip on bracket	WH				ea
RBC66040 LH	Left - suits clip on bracket	WH				ea





HARN - Impaz Drawer System

IMPAZ Internal Drawer - Front Fixing Brackets

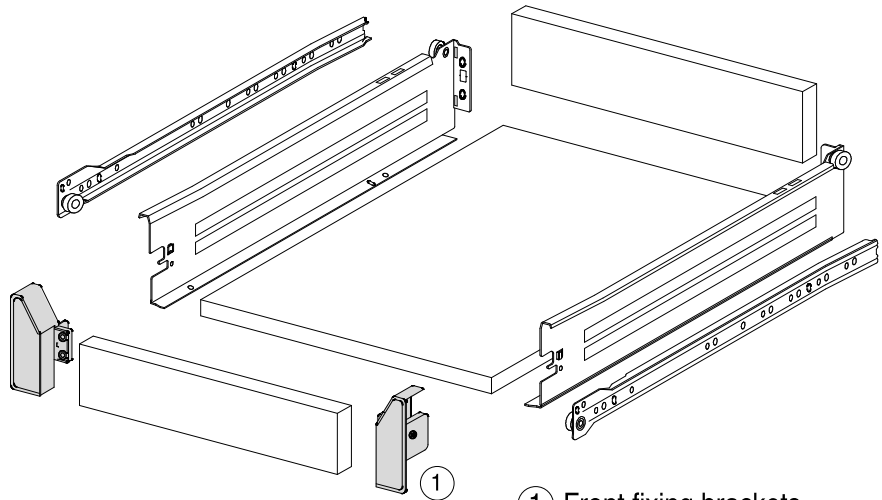
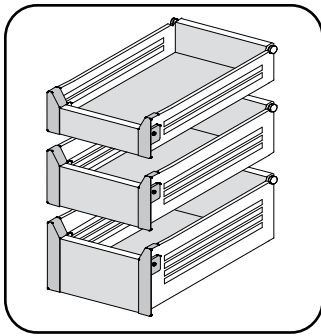

① Front fixing brackets
screw on

INTERNAL DRAWER FRONT FIXING BRACKETS SCREW ON

Part No.	Drawer Height		Finish	Price 100	Price 10	Price set	per
RBF31040 RH	85	Right	WH				ea
RBF31040 LH	85	Left	WH				ea
RBF33040 RH	117	Right	WH				ea
RBF33040 LH	117	Left	WH				ea
RBF36040 RH	149	Right	WH				ea
RBF36040 LH	149	Left	WH				ea

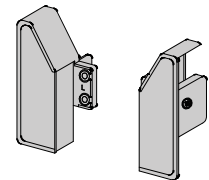

RBF31040, L + R

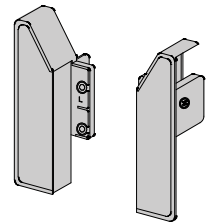

RBF33040, L + R

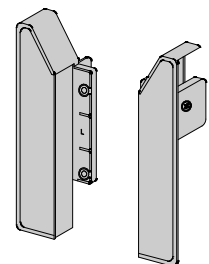

RBF36040, L + R

Cutting dimensions for 16mm chipboard

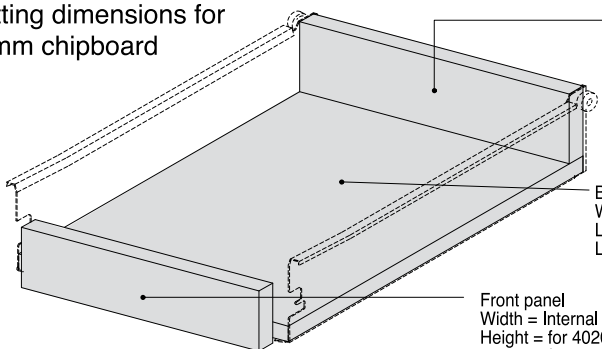

Back panel
Width = Internal cabinet width - 31mm
Height = for 4020/4021 = 71mm
for 4320/4321 = 103mm
for 4620/4621 = 135mm

Bottom panel
Width = Internal cabinet width - 31mm
Length (Wooden back) = Drawer length - 18mm
Length (Steel back) = Drawer length - 28mm

Front panel
Width = Internal cabinet width - 64mm
Height = for 4020/4021 = 61mm
for 4320/4321 = 93mm
for 4620/4621 = 125mm

Note : Min. internal cabinet depth = drawer length + 3mm





HARN - Impaz Drawer System

IMPAZ Railing System

③ Steel back

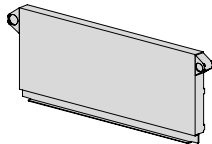

Refer Pg C.56

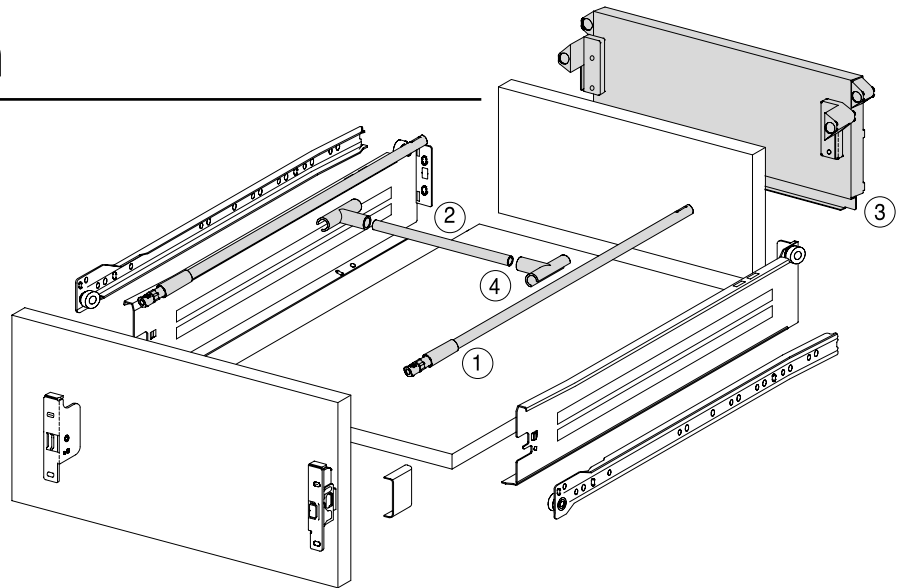

① Railing set

Adjustment railing L + R
Railing back fixing brackets L + R

- for wooden back

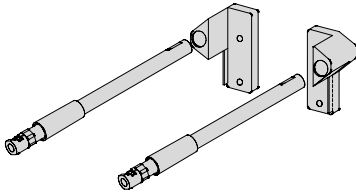

- for steel back

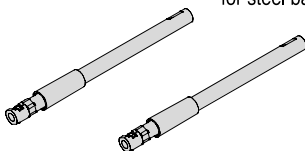

④ Cross railing connector

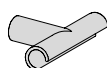

RAILING SETS

Railing sets for wooden back

Part No.	Drawer Length	Finish	Price 100	Price 10	Price set	per set
RRA.251.L	270	WH				set
RRA.331.L	350	WH				set
RRA.381.L	400	WH				set
RRA.431.L	450	WH				set
RRA.481.L	500	WH				set
RRA.531.L	550	WH				set

Railing sets for metal back

Part No.	Drawer Length	Finish	Price 100	Price 10	Price set	per set
RRA.251.S.L	270	WH				set
RRA.331.S.L	350	WH				set
RRA.381.S.L	400	WH				set
RRA.431.S.L	450	WH				set
RRA.481.S.L	500	WH				set
RRA.531.S.L	550	WH				set

CONNECTORS

Cross railing connectors

Part No.	Finish	Price 100	Price 10	Price set	per set
RRC.7200	WH				set





CROSS RAILING

Part No.	Cabinet Width (16mm Side Panel)	Finish	Price 100	Price 10	Price set	per
RRF.201.L	275	WH				ea
RRF.226.L	300	WH				ea
RRF.276.L	350	WH				ea
RRF.326.L	400	WH				ea
RRF.376.L	450	WH				ea
RRF.426.L	500	WH				ea
RRF.476.L	550	WH				ea
RRF.526.L	600	WH				ea
RRF.1000.L	1000	WH				ea

② Cross railing

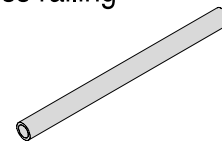

Front installation dimentions

4020/4021 - H 85mm

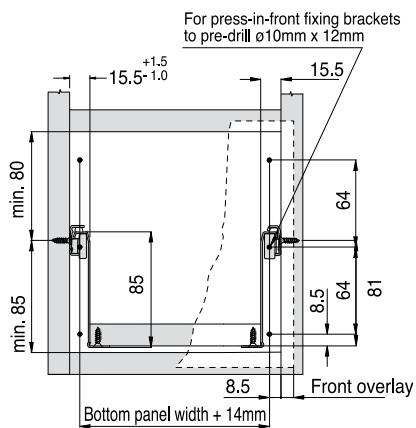

4320/4321 - H 117mm

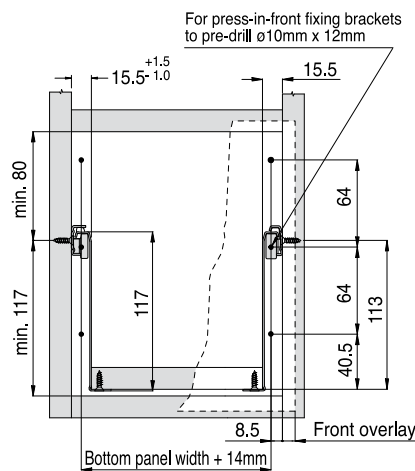

4620/4621 - H 149mm

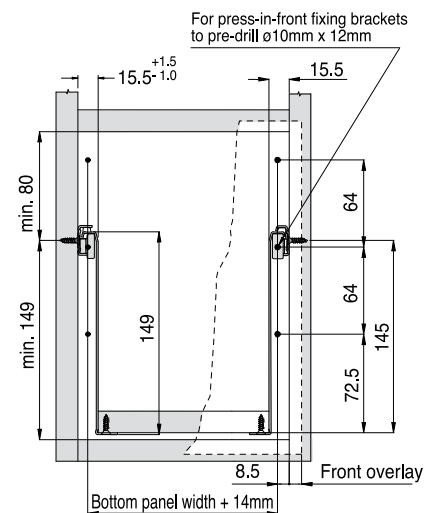

Back installation dimentions

4020/4021 - H 85mm

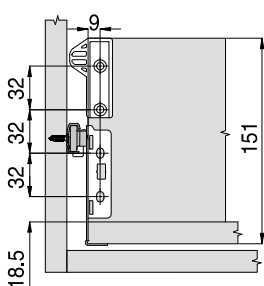

4320/4321 - H 117mm

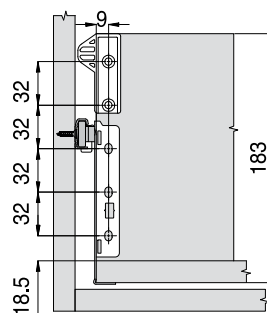

4620/4621 - H 149mm

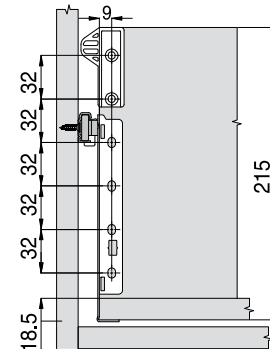



HARN - Impaz Drawer System

IMPAZ
Filing System

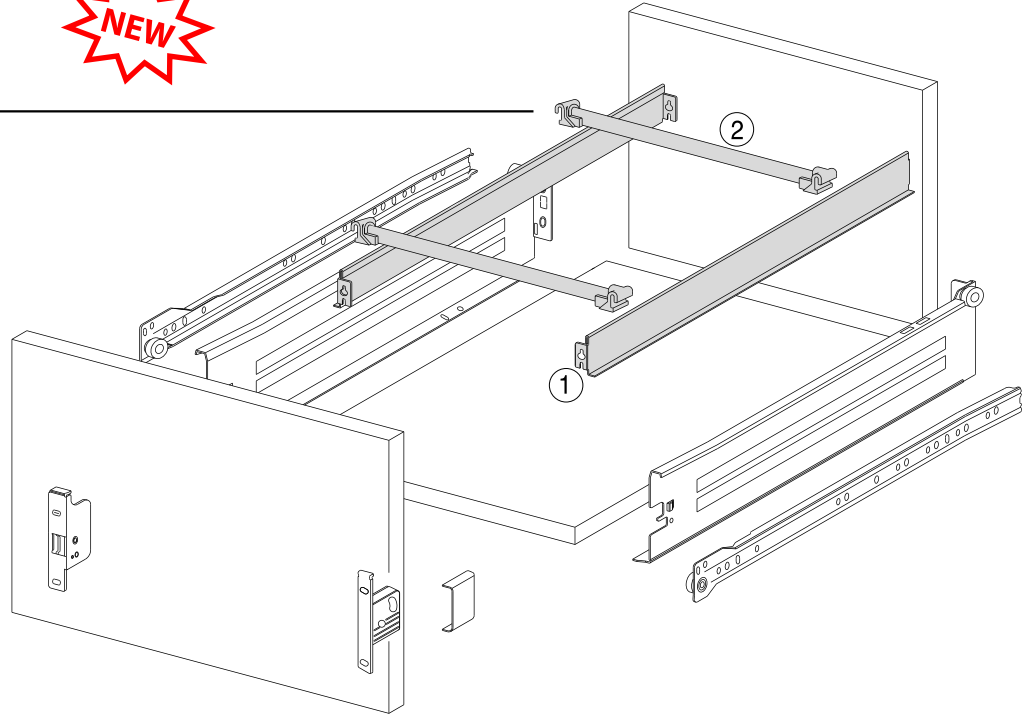

HARN IMPAZ FILING SYSTEM

For use with all Harn Impaz drawers.
Suits lateral or parallel files.
Side rails only

① Side hanging rail L+R

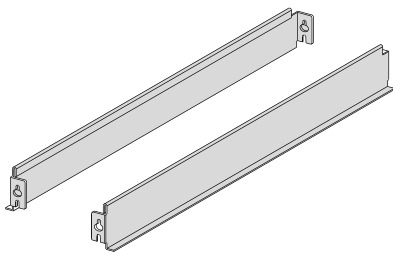

Part No.	Drawer Length	Finish	Price 100	Price 10	Price set	per
RMF.350	350	WH				pair
RMF.400	400	WH				pair
RMF.450	450	WH				pair
RMF.500	500	WH				pair
RMF.550	550	WH				pair

② Cross hanging rail x 2

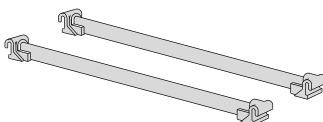

Part No.	Finish	Price 100	Price 10	Price set	per
RMF.000.377	Cross rails	WH			pair

Cutting dimension for
Cross hanging rail

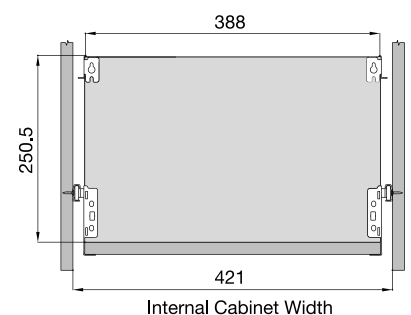
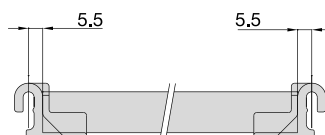



HARN - Impaz Drawer System

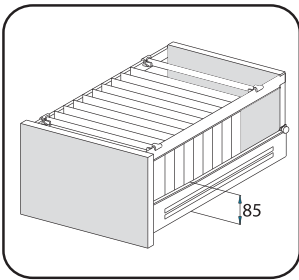

Front installation dimensions

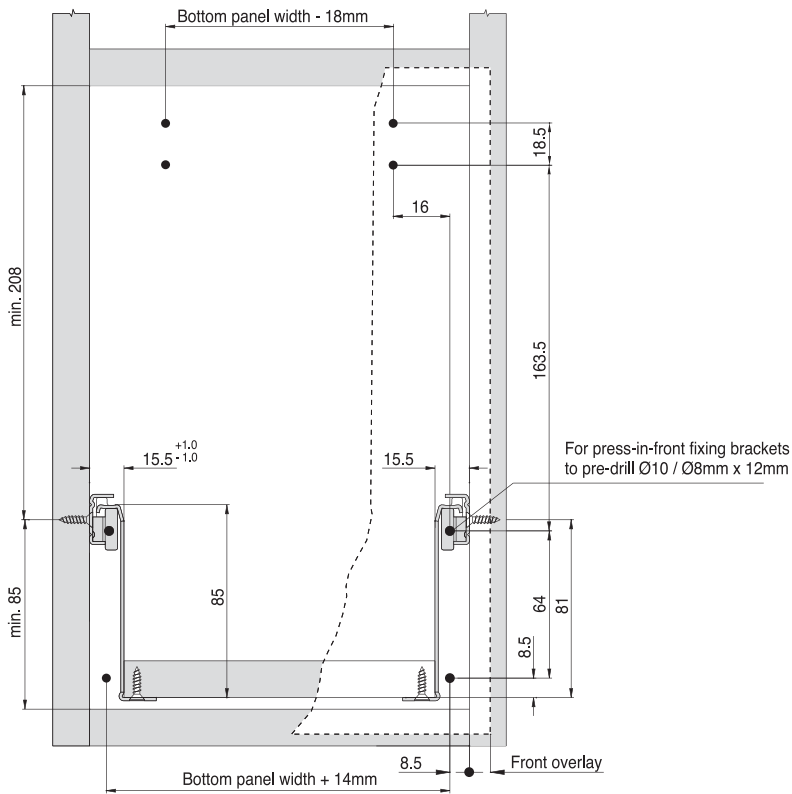

Back installation dimensions

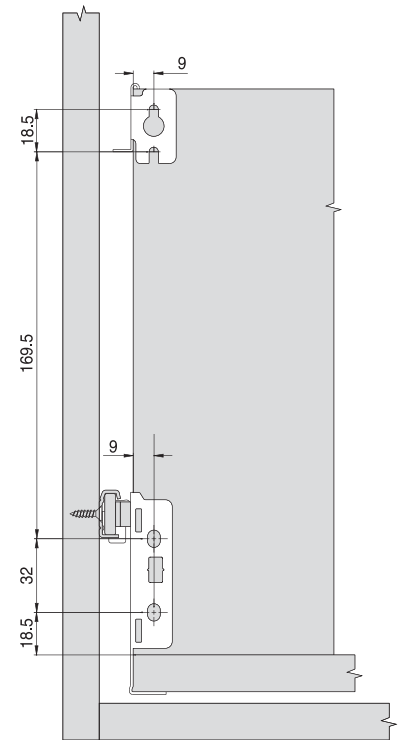

Drilling dimension of bottom panel for plug-in

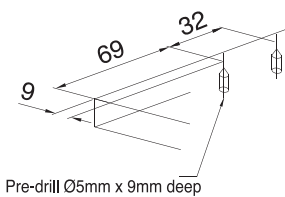

Cutting dimensions for 16mm chipboard

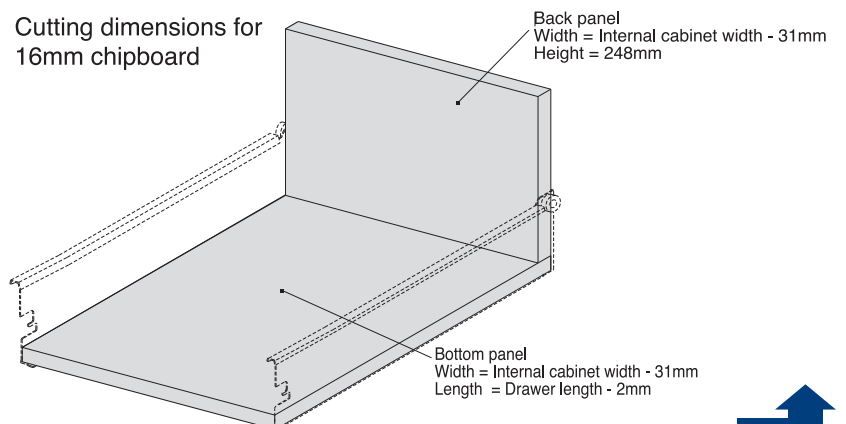



HARN - Impaz Drawer System

IMPAZ Side Extension

② Cross railing

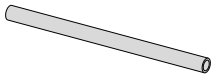

Refer Pg **C.52**

Cutting dimension

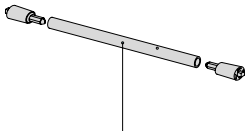

Width = internal cabinet width - 70 mm

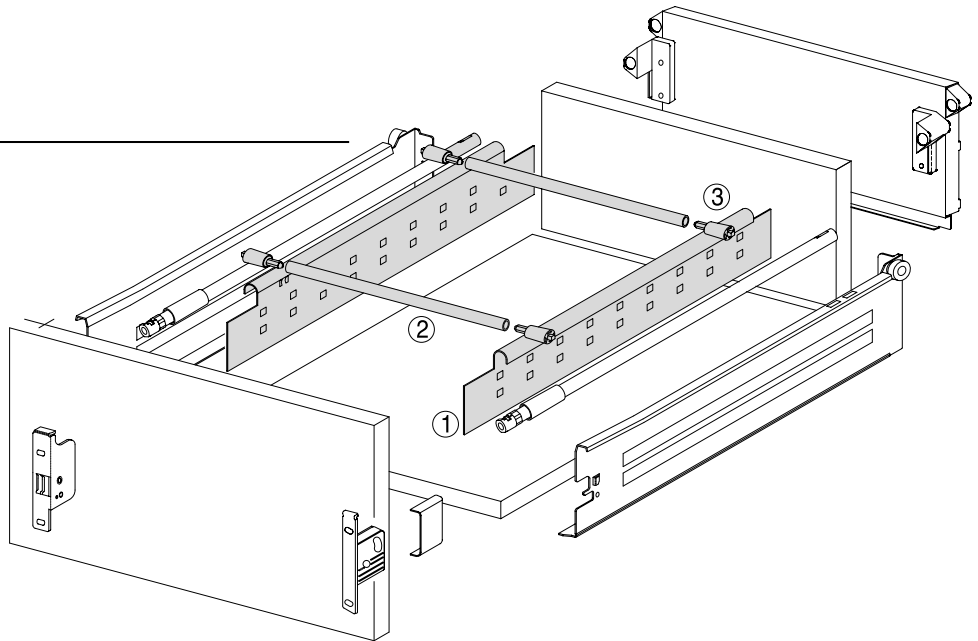

③ Cross railing connector

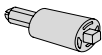

① Side panel - 64mm high

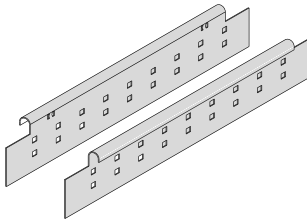

- 128mm high

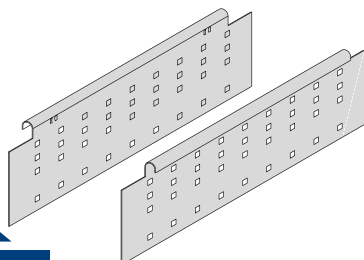

CROSS RAILING CONNECTOR

Spring loaded to suit side extensions

Part No.	Finish	Price 100	Price 50	Price ea	per
RRC.8500	WH, DG				ea

SIDE EXTENSION

Height 64mm

Part No.	Drawer Length	Finish	Price 100	Price 10	Price ea	per
RSE.064.350	350	WH				ea
RSE.064.400	400	WH				ea
RSE.064.450	450	WH				ea
RSE.064.500	500	WH				ea
RSE.064.550	550	WH				ea

Height 128mm

Part No.	Drawer Length	Finish	Price 100	Price 10	Price ea	per
RSE.128.350	350	WH				ea
RSE.128.400	400	WH				ea
RSE.128.450	450	WH				ea
RSE.128.500	500	WH				ea
RSE.128.550	550	WH				ea



HARN - Impaz Drawer System

STEEL BACKS

Steel back for standard
Impaz Drawer - Height 85mm

Part No.	Cabinet Width (16mm Side Panel)	Finish	Price 100	Price 10	Price ea	per
RSB.02.336	400	WH				ea
RSB.02.386	450	WH				ea
RSB.02.436	500	WH				ea
RSB.02.486	550	WH				ea
RSB.02.536	600	WH				ea
RSB.02.736	800	WH				ea

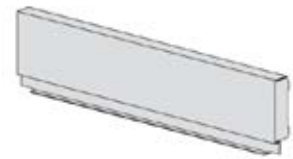

Steel back for standard Impaz
Drawer - Height 117mm

Part No.	Cabinet Width (16mm Side Panel)	Finish	Price 100	Price 10	Price ea	per
RSB.32.236	300	WH				ea
RSB.32.286	350	WH				ea
RSB.32.336	400	WH				ea
RSB.32.386	450	WH				ea
RSB.32.436	500	WH				ea
RSB.32.486	550	WH				ea
RSB.32.536	600	WH				ea
RSB.32.736	800	WH				ea

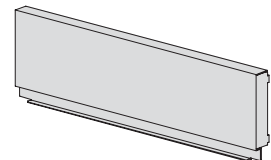



HARN - Impaz Drawer System

STEEL BACKS

Steel back for standard Impaz
Drawer - Height 149mm

Part No.	Cabinet Width (16mm Side Panel)	Finish	Price 100	Price 10	Price ea	per
RSB.62.386	450	WH				ea
RSB.62.436	500	WH				ea
RSB.62.486	550	WH				ea
RSB.62.536	600	WH				ea
RSB.62.736	800	WH				ea

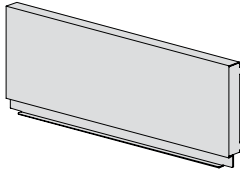

Steel back 149mm high to suit 85mm
Impaz Drawer with 64mm railing system

Part No.	Cabinet Width (16mm Side Panel)	Finish	Price 100	Price 10	Price ea	per
RSB.02R.386	450	WH				ea
RSB.02R.436	500	WH				ea
RSB.02R.486	550	WH				ea
RSB.02R.536	600	WH				ea
RSB.02R.736	800	WH				ea

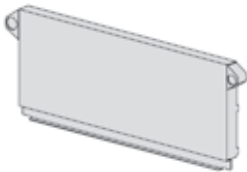



HARN - Basic Slides

For more information on Harn products see separate Harn brochures

SINGLE EXTENSION DRAWER RUNNERS

25kg Load rating. 1mm Thick

Part No.	Slide Length	Finish	Price 500	Price 20	Price set	per set
1012/25	250	WH				set
1012/30	300	WH				set
1012/35	350	WH				set
1012/40	400	WH				set
1012/45	450	WH				set
1012/50	500	WH				set

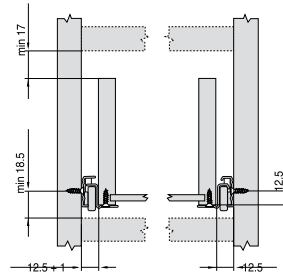

30kg Load rating. 1.4mm Thick

Part No.	Slide Length	Finish	Price 100	Price 20	Price set	per set
2030/40	400	WH				set
2030/45	450	WH				set
2030/50	500	WH				set
2030/55	550	WH				set
2030/60	600	WH				set
2030/65	650	WH				set
2030/70	700	WH				set

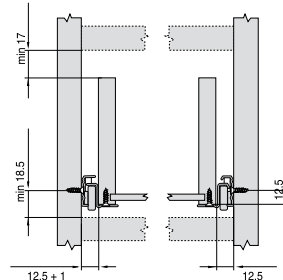

FULL EXTENSION DRAWER RUNNERS

40kg Load rating

Part No.	Slide Length	Finish	Price 100	Price 10	Price set	per set
3011/35	350	WH				set
3011/40	400	WH				set
3011/45	450	WH				set
3011/50	500	WH				set
3011/55	550	WH				set

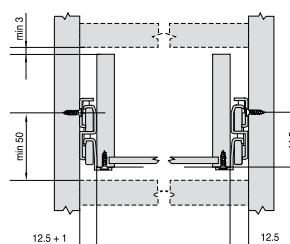

BACK



OFFICELINE System

- Quick assembly
- Keyhole front fixing with pre-mounted dowels
- Suits 3mm bottom panel
- Steel backs to suit various cabinet widths
- Filing system
- Pre-attached locking tabs
- Available in white, grey or black
- Machinery options available for production situations

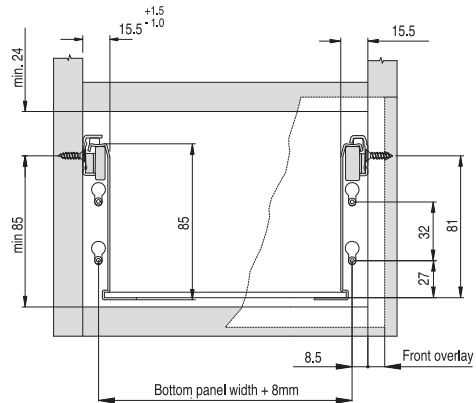

STEEL DRAWERS

450mm Long x 85mm High
Pre-mounted dowels
Minimum qty purchase 10

Part No.	Finish	Price 100	Price 10	Price set	per
403M/45	BL, WH, GY				set



FULL EXTENSION

450mm Long x 85mm High
Pre-mounted dowels
Minimum qty purchase 10

Part No.	Finish	Price 100	Price 10	Price set	per
503M/45	BL, WH, GY				set



Harn - Officeline Drawer System

OFFICELINE System

- Steel backs & file systems - Type A
- Suits officeline drawers 403M/503M
- Internal cabinet width 421mm

STEEL BACK & BOTTOM PANEL SUPPORT

Standard back & bottom panel support
85mm High
Minimum qty 10



Part No.	Finish	Price 100	Price 10	Price ea	per
RSB.03M.390	BL, WH, GY				ea



HIGH BACK FOR FILING SYSTEM

Supplied with bottom panel support
248mm High
Minimum qty 10



Part No.	Finish	Price 100	Price 10	Price ea	per
RSB.03MF.390	BL, WH, GY				ea



FILING SYSTEM SUITS LATERAL OR PARALLEL FILING

450mm Long
Side rails to suit RSB.03MF.390
Minimum qty 10



Part No.	Finish	Price 100	Price 10	Price ea	per
RMF.450ML Left	BL, WH, GY				ea
RMF.450MR Right	BL, WH, GY				ea



Lateral rails to suit RMF.450M L+R



Part No.	Finish	Price 100	Price 10	Price pair	per
RMF.000.377	BL, WH, GY				pr





HARN - Officeline Drawer System

OFFICELINE System

- Steel backs & file system - Type B
- Suits officeline drawers 403M/503M



STEEL BACK & BOTTOM PANEL SUPPORT

Internal cabinet width 310mm
85mm High
Minimum qty 10

Part No.	Finish	Price 100	Price 10	Price ea	per
RSB.03M.279	BL, WH, GY				ea



Internal cabinet width 417mm
85mm High
Minimum qty 10

Part No.	Finish	Price 100	Price 10	Price ea	per
RSB.03M.386	BL, WH, GY				ea



STEEL BACK

Internal cabinet width 858mm
85mm High
Minimum qty 10
Suits 2 x RMF.453.387 file systems (see page C.62)

Part No.	Finish	Price 100	Price 10	Price ea	per
RSB.03M.827	BL, WH, GY				ea





OFFICELINE System

- Steel backs & file systems - Type B
- Suits Officeline drawers 403M/503M

PLASTIC BOTTOM PANEL SUPPORT

Staple grade plastic
Suits 3mm bottom panel
1.8m Lengths

Part No.	Finish	Price 100	Price 10	Price length	per
BPS.FMP.18	WH				Length

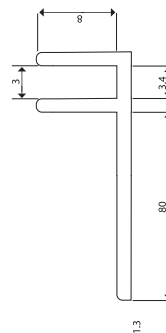

FILING SYSTEM

Suits lateral or parallel Filing
Suits 403M/503M drawers
Includes; 2 x Vertical uprights,
2 x Parallel rails, 1 x Back rail,
2 x Lateral rails with connectors.



Internal cabinet width 310mm.

Part No.	Finish	Price 100	Price 10	Price set	per
RMF.453.280	BL, WH, GY				Set



Internal cabinet width 417mm.
(or 2 units side by side on RSB.03M.827 back pg C.61)

Part No.	Finish	Price 100	Price 10	Price set	per
RMF.453.387	BL, WH, GY				Set

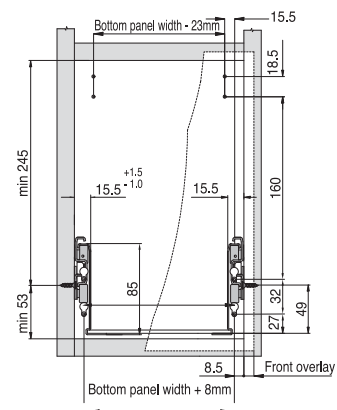



HARN - Marking Devices

TRIOMAX

triomax

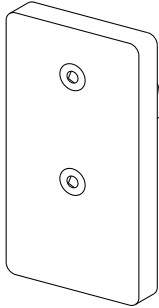

Drawer Front Marking Jigs

Article No.

RMD.91130

6 Marking Pins Included

Application

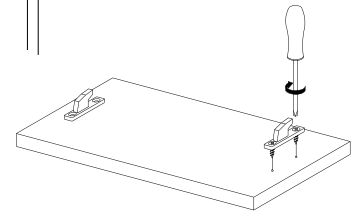
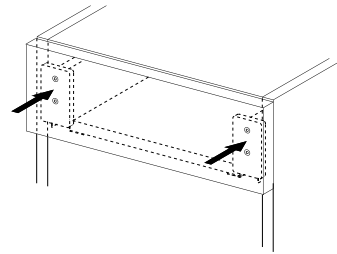
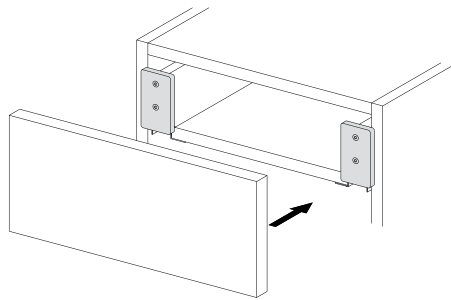

Part No.	Price Set	per
RMD.91130		Set

IMPAZ

impaz

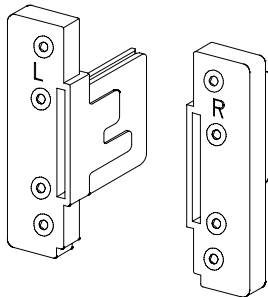

Drawer Front Marking Jigs

Article No.

RMD.91040

L + R, 6 Marking Pins Included

Application

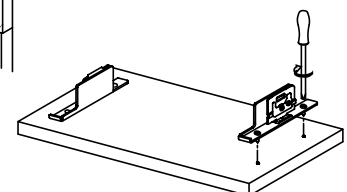
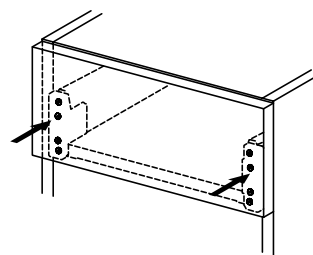
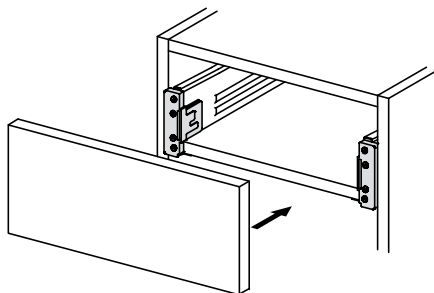

Part No.	Price Set	per
RMD.91040		Set

BACK



Horn - Marking Devices

TRIOMAX

Railing Marking Template
For marking single and double railing

Article No.

RMD.92130

Application

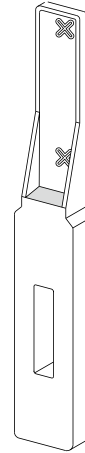
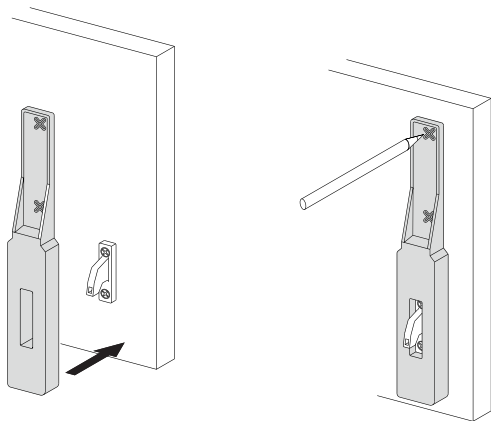

triomax

Part No.

RMD.92130

Price Set

per

ea

IMPAZ

Railing Marking Template
For marking single and double railing

Article No.

For Standard Brackets
RBF 11040 / RBF 12040 / RBF 13040

For Clip On Brackets
RBF 16040 / RBF 17040 / RBF 18040

RMD.92040

RMD.93040

Application

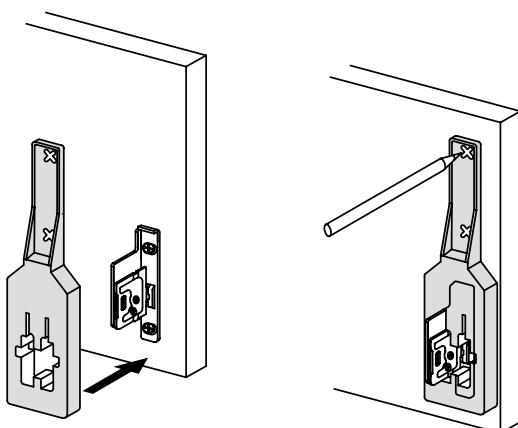

impaz

Part No.

RMD.92040

RMD.93040

Price Set

per

ea

ea

BACK



TRIOMAX Hand Insertion Ram

triomax

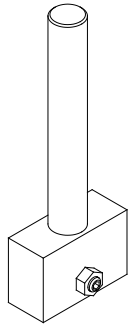

Part No.	Price ea	per
RME.95131		ea

IMPAZ Hand Insertion Ram

For insertion of press-in front fixing bracket

impaz

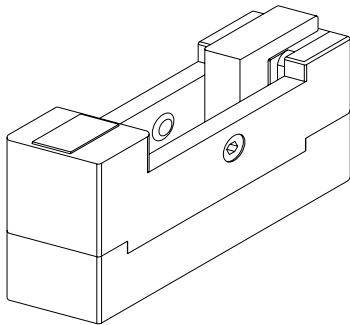

Part No.	Price ea	per
RME.95041		ea
RME.96041		ea

	for Bracket RBF.12040	for Bracket RBF.17040
Article No.	RME.95041	RME.96041

IMPAZ Machine Insertion Ram

For insertion of press-in front fixing bracket

impaz

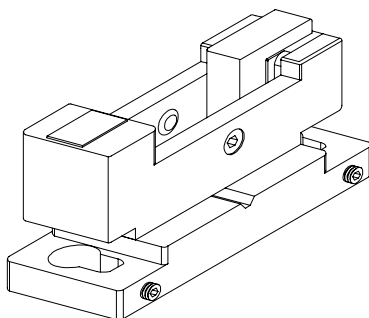

Part No.	Price ea	per
RME.95040		ea
RME.96040		ea

	for Bracket RBF.12040	for Bracket RBF.17040
Article No.	RME.95040	RME.96040

[BACK](#)



Harn - Drilling Jig / Technical Manual



TRIOMAX / IMPAZ

Drilling Template

For drilling or marking bottom panel and back panel

Article No.

RMD.930.00

Included one ø5mm marking pin and one ø5mm stop collar

Application

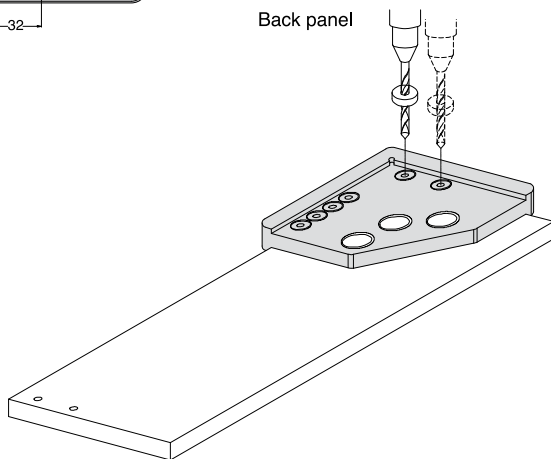
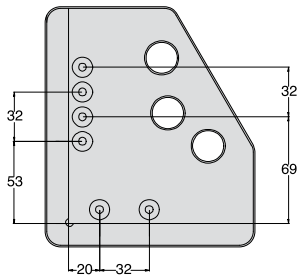
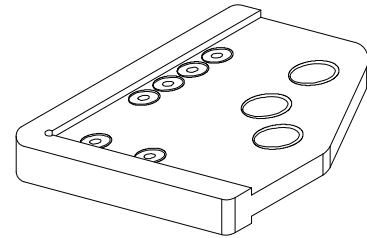

Bottom panel

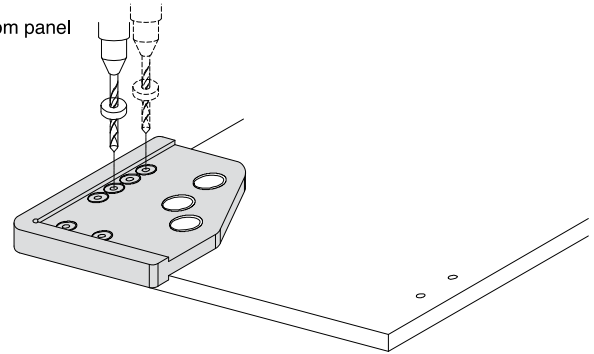

Part No.	Price ea	per
RMD.930.00		ea

HARN TECHNICAL MANUAL

Triomax / Impaz

Part No.	Price ea	per
HTM.01		ea

