



*Building better choice*



NOW AVAILABLE WITH

**BAL29**  
FIRE RATING

## Euro Seleкта Clad

# Euro Seleкта Clad

EC 155 x 18 DARK CEDAR

## Composite cladding at its finest

Urbanline Euro Seleкта Clad is a unique, pre-finished composite cladding façade with a beautiful timber-grain-embossed surface. Designed for stability and longevity with style, Euro Seleкта Clad is eco-friendly, maintenance free and incredibly easy to install.

The easy-to-use and lightweight tongue and groove profile makes installation a breeze, with machined screw slots for added convenience. Euro Seleкта Clad also offers versatility, with seven natural wood colours and the attractive Coast White colour in stock for immediate supply, as well as a wide range of specialty colours that can be pre-ordered as required. This fabulous composite can be installed both vertically and horizontally, as well as diagonally.

Euro Seleкта Clad has a large coverage width of 155mm. It can also cater to individual requirements, with

a range of smart, corrosion-resistant aluminium trims and accessories on offer.

Euro Seleкта Clad is made using a patented manufacturing process, which combines the natural properties of wood, with the resistance of high-quality resins. During this process, the coating is permanently melted to a highly-compressed material core and then sealed. The practical benefits of this process are clear. To prove the advantages, this product has been subjected to extreme endurance tests, including swell tests and paint flaking tests. In special

climate chambers, the material is subjected to a range of environmental conditions and temperature fluctuations between -30° and +70° Celsius. The product responded brilliantly to these tests, outlasting wind and weather for 30 years.

Euro Seleкта Clad is also a great choice for the environmentally conscious. The timber component of this product is sourced from PEFC Certified sustainably managed forests.

Now Euro Seleкта cladding is approved to be installed on any building in a bushfire prone area rated up to BAL29\*.



NOW AVAILABLE WITH  
**BAL29**  
FIRE RATING

EC 155 x 18 DARK CEDAR



EC 155 x 18 SILVER OAK



## Profiles

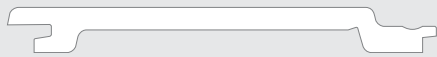

EC 155 x 18

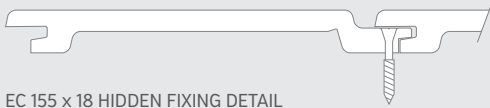

EC 155 x 18 HIDDEN FIXING DETAIL



### CAD files

Download the latest CAD files from the product section of [urbanline.com.au](http://urbanline.com.au)

EC 155 x 18 AFRICAN EBONY

## Euro Seleкта Clad

Profile Code	Profile Width (mm)	Cover (mm)	Thickness (mm)	Profile Length (mm)	Max Spans (mm)	Certification	Linear metre per m <sup>2</sup>	Weight per m <sup>2</sup>
EC 155 x 18	170	155	18	5400	625	PEFC Certification Group Fire Rating Acoustic Rating	6.45	9.7kg

## Colours\*

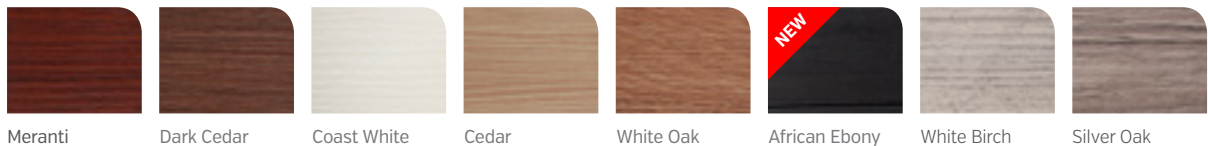

Meranti

Dark Cedar

Coast White

Cedar

White Oak

African Ebony

White Birch

Silver Oak

\* Other colours available on request

EC 155 x 18 DARK CEDAR

## Clever cladding

Euro Seleкта Clad looks and feels like real timber and is virtually maintenance free – the perfect solution for:

- External feature facade cladding for domestic and commercial applications
- Coastal/beach-front areas
- Difficult access areas
- Low-maintenance substitute for timber feature cladding
- Internal feature walls
- High-exposure areas
- Feature facade cladding for multi-story apartment buildings, where maintenance is difficult
- Feature cladding for soffits
- Gable ends



Acoustics



Fire Rating

EC 155 x 18 DARK CEDAR

EC 155 x 18 DARK CEDAR

EC 155 x 18 DARK CEDAR

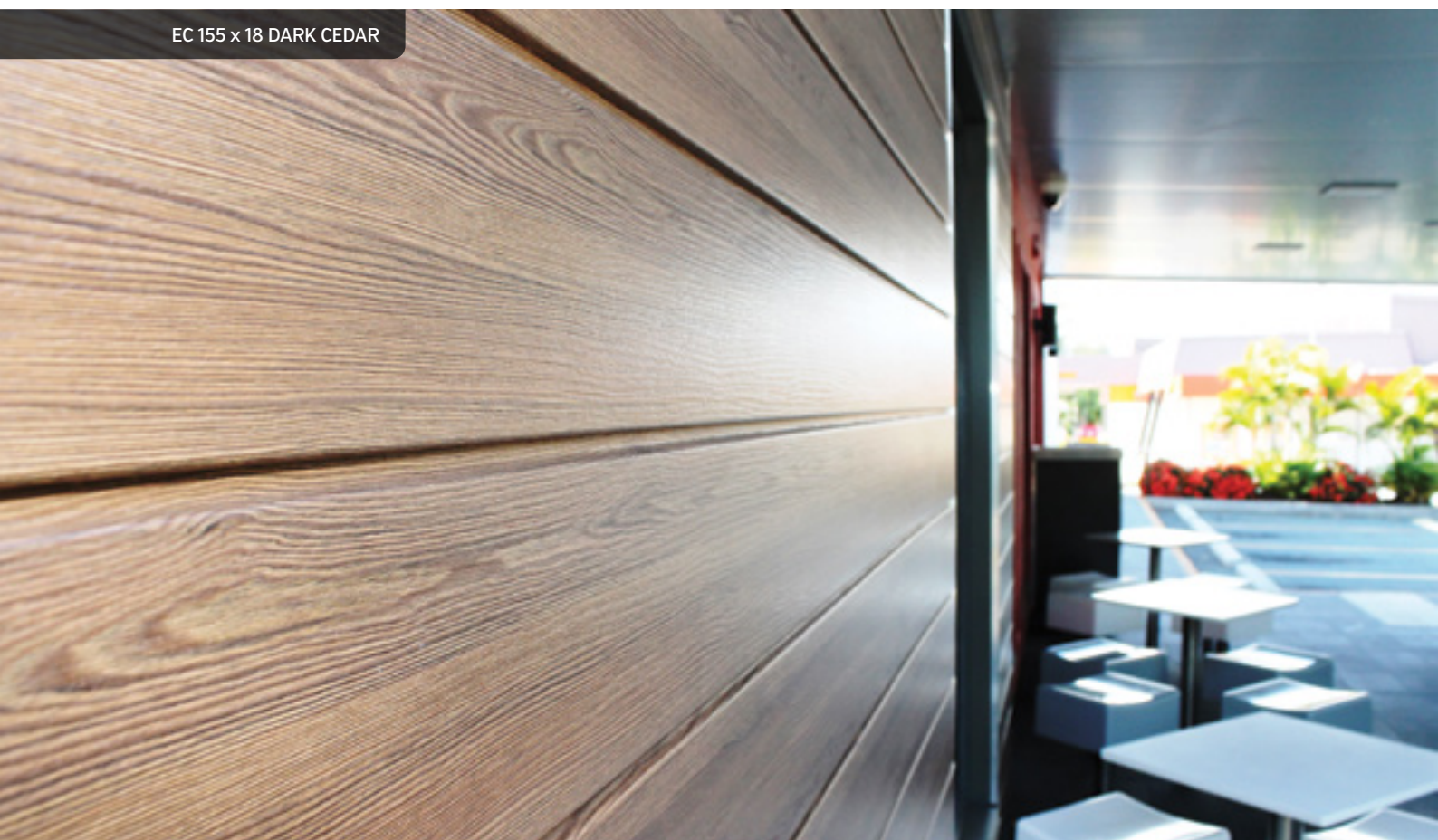

There are so many great reasons to choose Euro Seleкта Clad



#### Sizing

5.4m length and 155mm cover / 6.45 L/M per m<sup>2</sup>



#### Water resistant

Finely-chopped wood, with uniform, homogeneous structure and high-quality resins for strong bonding, guarantee the highly-compressed and dimensionally-stable material structure.



#### PEFC certified

Timber components sourced from PEFC Certified sustainably managed forests.



#### Hidden fixing system

Simple tongue and groove fixing system with machined screw slots.



#### Non leaching

The only timber-look cladding that cannot leach as there are no tannins impregnated into the profile.



#### High R<sub>w</sub> acoustic rating

Laboratory acoustic testing results available



#### Installer friendly

Pre-finished profiles and simple tongue and groove fixing system makes for quick and easy installation.



#### Ideal timber substitute

Perfect for use in high-exposure or difficult-to-access areas.



#### Rot and pest resistant

Guaranteed not to rot, split, warp or check. Highly resistant to damage caused by termites and fungal decay.



#### Comprehensive 10 Year Warranty

Guaranteed quality and peace of mind. Visit [urbanline.com.au](http://urbanline.com.au) for more information.



#### Accessories available

Range of smart, corrosion-resistant aluminium trims and accessories available. Ask our helpful staff for more information.



#### Bushfire resistance

[AS/NZ 3837].  
Now Euro Seleкта cladding is approved to be installed on any building in a bushfire prone area rated up to BAL29\*.

\*Subject to the Building Code of Australia.



## Accessories

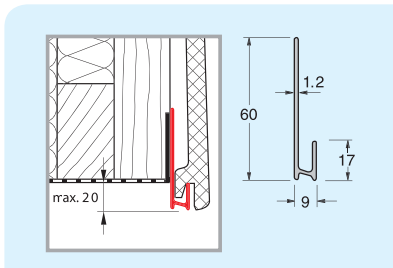

**ECHSP**  
Starting Profile P / Horizontal Starter Profile

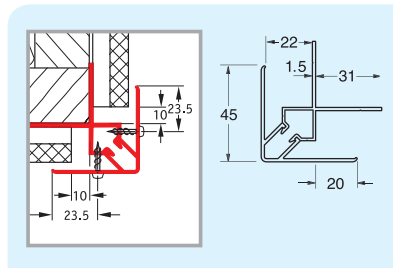

**ECACE/I**  
External / Internal Corner Profile

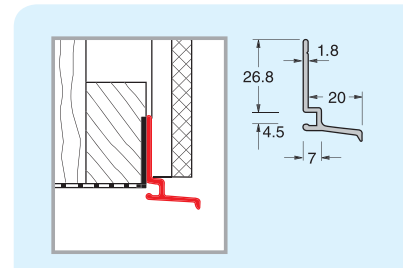

**ECVSP**  
Layering Profile / Vertical Starter Profile

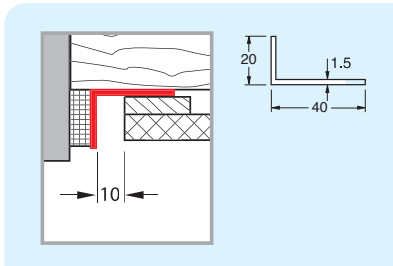

**ECA40**  
Angle 40 x 20  
\* Cover angle available in 40 x 20 & 20 x 20

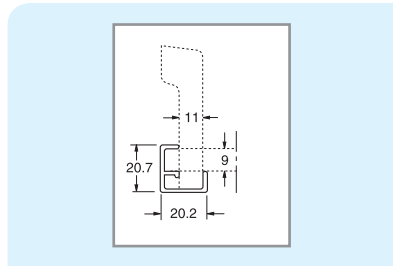

**ECET**  
Edge Trim Profile

### Anodised Aluminium Trims and Accessories

Product Code	Product Description	Length (mm)	Product Code	Product Description	Length (mm)
ECHSP	Starting Profile P / Horizontal Starter Profile	5500	ECACE/I	External / Internal Corner Profile	5500
ECVSP	Layering / Vertical Starter Profile	5500	ECJCP	Joint Cover Profile	5500
ECZP	Z Profile	5500	ECFP	Connection Profile F	5500
ECA20	Angle 20 x 20	5500	ECA40	Angle 40 x 20	5500
ECCC	Cover Cap 46 x 46	N/A	ECCS	6G x 32 Stainless Screws	N/A



EC 155 x 18 SILVER OAK



EC 155 x 18 MERANTI

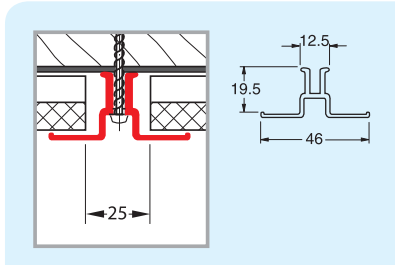

ECJCP  
Joint Cover Profile

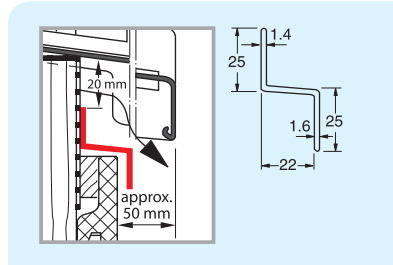

ECZP  
Z Profile

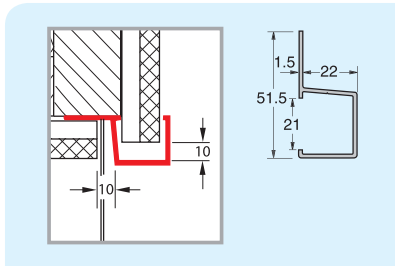

ECFP  
Connection Profile F

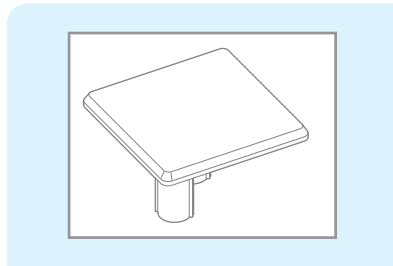

ECCC  
Cover Cap

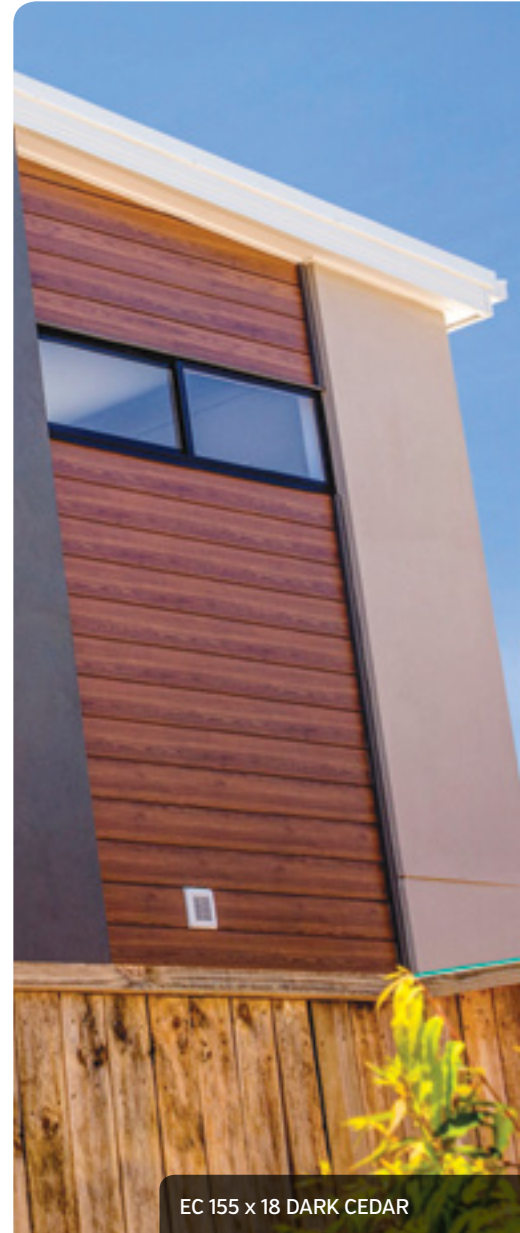

EC 155 x 18 DARK CEDAR

## Project Profile



EC 155 x 18 CEDAR

# Quest Apartments, Brisbane: Attractive carpark welcomes guests

**Location** Woolloongabba  
**Builder** Redstar Industries

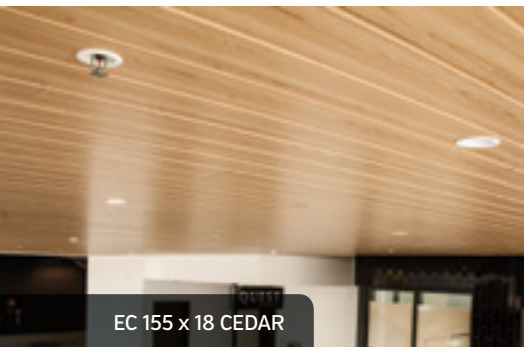

EC 155 x 18 CEDAR



EC 155 x 18 CEDAR



EC 155 x 18 CEDAR

## Entrance Statement

Guests arriving at the new Quest Apartments at Woolloongabba in Brisbane are welcomed by a stylish entrance to the underground carpark thanks to Urbanline's Euro Selekt Clad Composite. Located at the busy corner of Logan and Deshon St, the installation occurred in mid-2014.

## The Look of Cedar

Around 300m<sup>2</sup> of Euro Selekt Clad in Cedar was used to great effect. This pre-finished, composite cladding façade has a timber-grain-embossed surface, made of finely-chopped wood with uniform structure. Leaching is avoided as there are no tannins in the profile, while tongue and groove fixing ensures easy installation.

## Low-Maintenance Durability

Euro Selekt Clad was selected not only for its looks, but for its stability and longevity. What's even better is that it's eco-friendly, maintenance free, and incredibly easy to install. It's perfect to use in high-exposure or difficult-to-access areas, and will not rot, split, warp or check.



EC 155 x 18 CEDAR

EC 155 x 18 CEDAR

Guests at Brisbane's new Quest Apartments are welcomed by a stylish, timber-look entrance to the underground carpark, thanks to Euro Selekt Clad Composite.

EC 155 x 18 CEDAR

## Project Profile

EC 155 x 18 DARK CEDAR

# Zest Apartments, Canberra: Standing out in a tight market

**Location** Franklin  
**Builder** Meteora Developments



### Affordable Appeal

Surrounded by contemporary apartments posed two challenges for architect Fred Kasperek in designing the 78-unit Zest Apartments: affordability and differentiation. "Creating a product that looked highly appealing but stayed affordable was a top priority in such a difficult market," Fred said. The Zest development comprised 39 one-bedroom units, 35 two-bedroom units and four three-bedroom units, plus a basement carpark.

### Composite Timber Adds Warmth

With an exterior of rendered brickwork and lightweight cladding, Kasperek looked for something extra to attract potential buyers. "The building needed to be softened with a tactile dimension that would create warmth," he said. "Timber creates this effect, but it's not popular with buyers when it weathers and adds to the body corporate maintenance bill. So I looked for a composite product that was convincing yet practical."

### Feature Panels Stand Out

Kasperek turned to Urbanline's Euro Clad composite cladding which has a timber-embossed surface. Feature panels were added to the blades of the building, which also ensured there were no harsh blank walls. In Kasperek's words, the cladding "made the building stand out from the rest, with many people commenting on how attractive it was." Of course, the proof lies in market acceptance, and Zest achieved strong sales.

EC 155 x 18 DARK CEDAR



EC 155 x 18 DARK CEDAR



Cladding “made the building stand out from the rest, with many people commenting on how attractive it was.”



EC 155 x 18 DARK CEDAR

# Not yet convinced on composites?

Get confident by becoming composite competent.

Urbanline offers Australia's largest range of high-performing composite products made out of the best fine wood waste and plastics, using the latest technology.

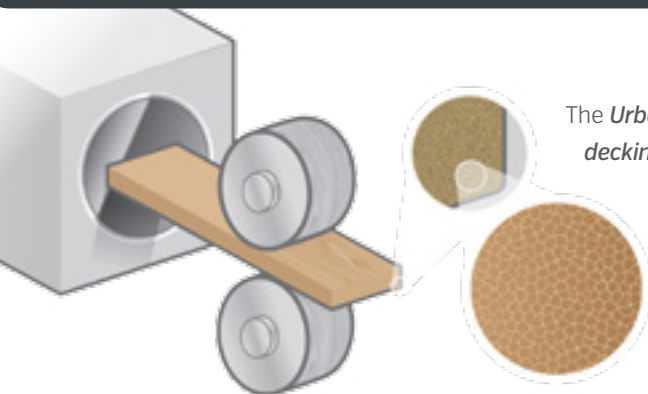
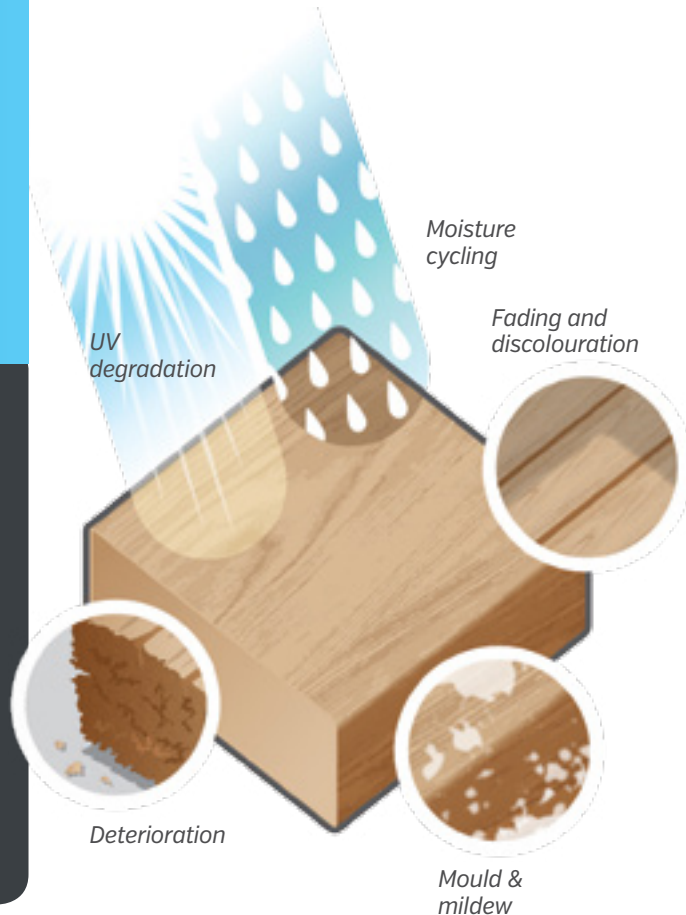

Latitudes Duro Decking

The *Urbanline Latitudes Duro decking and cladding* has been made in the USA for the last 30 years using the Strandex Process. This means every strand of wood fibre is encased in high-density polyethylene for minimal movement and to give superior protection against UV and moisture. Each wood fibre

is ground to a fine consistency for a uniform look and a screen in the extrusion process orients the material into rope-like strands that are wound together for strength.

This is why this product has an unbeatable guarantee of 25 years. Latitudes is the only composite manufacturer in the USA to extrude decking with this process.

## Here's what to look for:

- ✓ A comprehensive guarantee
- ✓ Choice of colours and finishes
- ✓ A uniform look through smaller wood fibres
- ✓ Low moisture and decay resistant being dense with high talc concentration
- ✓ Low thermal expansion
- ✓ Secret fixing system
- ✓ High-impact resistant
- ✓ Dimensional and directional stability with low expansion and contraction
- ✓ UV and fade resistant
- ✓ Handles temperature fluctuations
- ✓ Non-rot and pest resistant
- ✓ Non-staining
- ✓ Inherent microbiological properties

**Euro Clad Composite cladding** is manufactured in Germany using a patented manufacturing process combining the natural properties of wood with the resistance of high quality resins.

The finely chopped, fresh domestic wood with uniform, homogeneous structure and high quality resins for strongbonding of the chips, guarantee the highly compressed and dimensionally stable material structure.

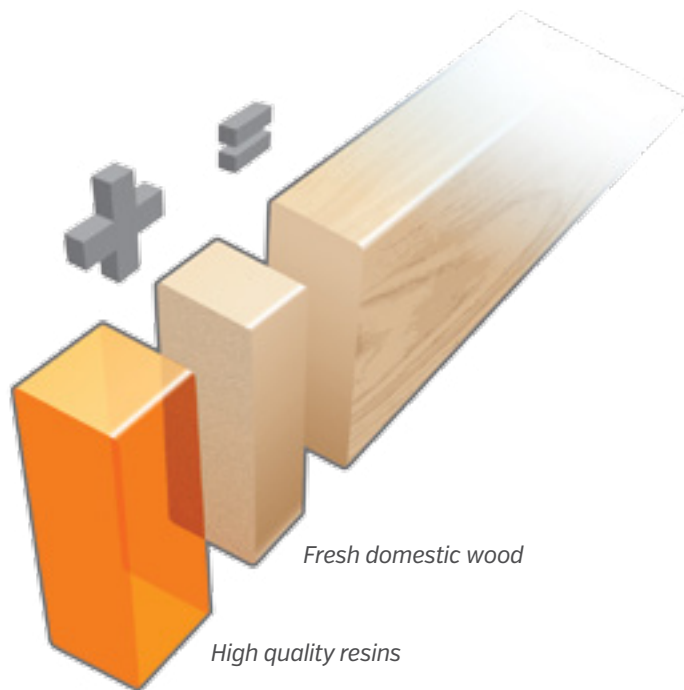

**Euro Clad Composite Cladding**

Interestingly, some products such as **Millboard decking** contains no wood or plastic but is made from polyurethane resin (not plastic) with mineral stone flour commonly referred to as Resin Mineral Composite [RMC]. It also contains glass fibres to give extra exceptional strength. Other ingredients are high quality colour pigmentation and high-tech ultraviolet light inhibitors for durability and lasting beauty.

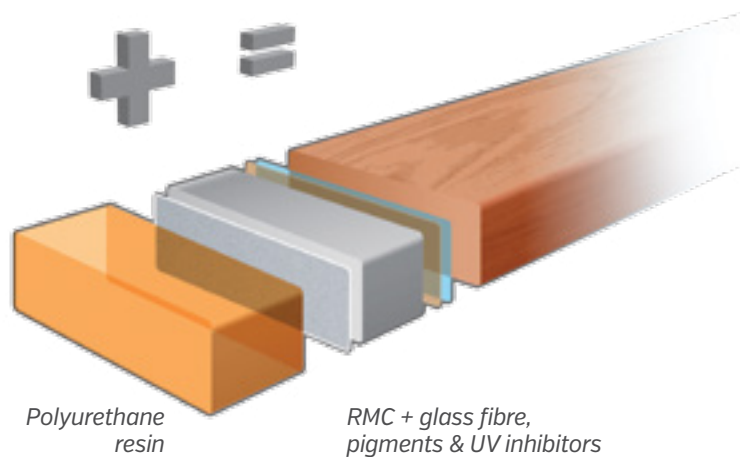

**Millboard Decking**

## Composites cut costs



### Time & cost

Time and cost savings during construction through quick installation and less overheads (e.g. scaffolding, tradesmen labour and painting costs).



### Durable

The long-lasting, durable nature of composite cladding and extended service life ensures the greatest payback on investment.



### Energy efficient

Long-term building performance and energy efficiency.



### Low maintenance

Minimal to no ongoing maintenance. Consideration needs to be given to overall cost savings of no maintenance materials, labour, scaffolding and access restrictions over a long period.

Further product information and downloads for Euro Selekt Clad are available at [urbanline.com.au](http://urbanline.com.au)



Installation instructions



Product care



CAD files



Technical information



## Like what you see?

Get in touch and order your free sample today!

Phone 1300 658 638 Email [sales@urbanline.com.au](mailto:sales@urbanline.com.au)

For further product information and downloads Visit [urbanline.com.au](http://urbanline.com.au)



*Building better choice*