



Thermoduo™ is a heavy duty underfloor heating system designed for use in concrete screeds...

- ✓ Robust 7mm cable designed for use in screed
- ✓ Can be cable tied to reinforcing steel
- ✓ Available in 10W/Lm for suspended floors
- ✓ Available in 30W/Lm for use in concrete
- ✓ Simple, fast installation
- ✓ Can be used with off peak electricity tariffs

ROBUST & VERSATILE IN SCREED HEATING CABLE

Thermoduo™ is a brilliantly versatile, robust 7mm underfloor heating cable designed for use in screed.

Install the cable in the concrete slab or screed layer of new builds to create an energy efficient thermal mass under your floor.

Thermoduo™ 10W/Lm can also be used in an air void in specific applications.

ENHANCE EVERY PROJECT

Enhance your project with Thermoduo™ premium quality in screed heating cable. The Thermonet® experience guarantees a hassle free installation and ultimate comfort.



INCLUDED IN THE RANGE

- Thermoduo™ 10W/Lm
- Thermoduo™ 30W/Lm
- Edge Insulation Strip
- Cable Channel and Cover (joisted floors)
- Cable Ties
- Galvanised Fixing Profile

YOU MAY ALSO NEED:

- Thermostat
- Backbox
- Cable Ties
- Galvanised Fixing Profile
- Edge Insulation Strip
- Cable Channel and Cover (joisted floors)



USE WITH OFF PEAK ELECTRICITY TARIFFS

Thermoduo™ In Screed Heating can be a very cost effective system in its own right, but you can unlock further savings by taking advantage of an off peak electricity tariff.

Program your Thermoduo™ system to switch on during off peak times and warm your concrete screed, similar to a storage heater. Enjoy the comfort for the rest of the day as the heat radiates from your heated screed.

EASY INSTALLATION

Thermoduo™ can be installed using the galvanised fixing profile or, in new build applications you can simply cable tie it to the reinforcing steel before pouring the concrete slab.

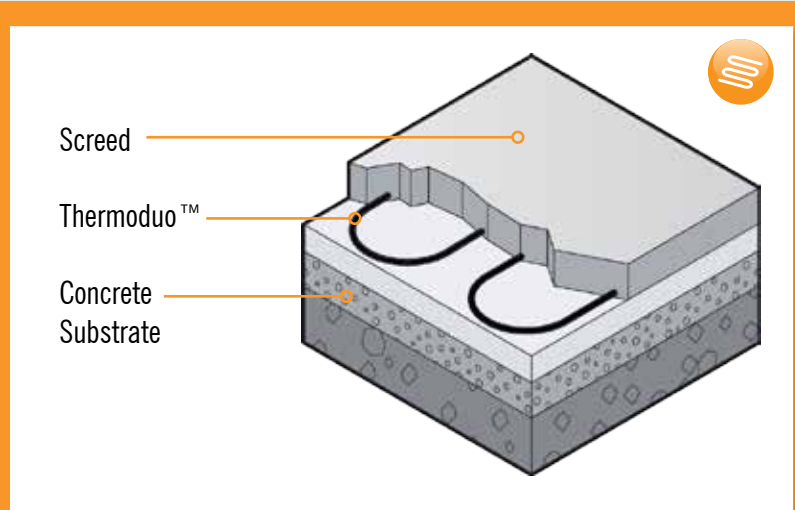

Economical in screed heating

Thermoduo™ In Screed Heating Cable is designed for installation in the concrete screed layer of your floor and will provide a responsive heating system under any floor covering. This application is increasingly popular in new build homes as it can be very cost effective and efficient when properly insulated and programmed with an economical heating schedule.

Thermoduo 30W/lm

STOCK NO	SIZE (LM)	OUTPUT (W)
3140	29	850
3142	38	1100
3144	47	1400
3146	57	1700
3148	67	2000
3150	75	2250
3152	84	2500
3154	94	2800
3156	112	3350
3158	134	4000
3160	150	4500
3162	168	5000
3164	200	6000

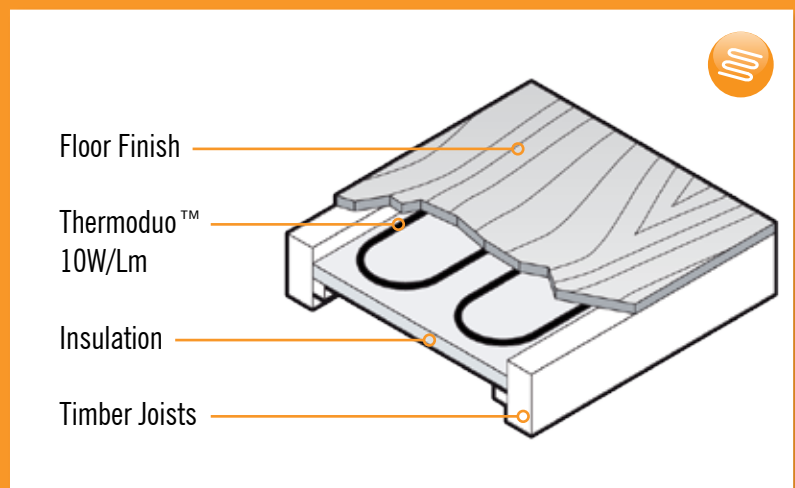

Use with different finishes and substrates...

Thermoduo™ 10W/Lm can also be used in an air void over polyurethane foil faced rigid insulation boards. The insulation must be at least 25mm thick and there must be an air space of at least 25mm between the insulation and floor finish.

Thermoduo 10W/lm

STOCK NO	SIZE (LM)	OUTPUT (W)
3102	21	210
3104	42	420
3109	89	890
3110	104	1040
3115	150	1500
3120	198	1980

©Thermogroup UK 2013 E&OE TDUO_01_13

CONTACT US ONLINE

Browse our full product range, watch videos, download product literature and get a quote, all on the Thermogroup UK website.

www.thermogroupuk.com

CONTACT US BY PHONE

Got a question or query? Call our UK support line free from your land line. Open 07:30 - 16:30 Mon - Fri

0800 019 5899

CONTACT US BY MAIL

Tell your satnav where to find us or just write us a letter to say hello!

Thermogroup UK, Bridge House, Hop Pocket Lane, Paddock Wood, Kent. TN12 6DQ.