



Scarborough Series[®] Window shroud feature screen



The Louvreclad Scarborough Series[®] is a modular 20mm suite available in ellipsoid, bullet, and panel configurations. A versatile, cost-effective alternative to traditional feature fins and screens. It's slim profile provides substantial sun screening and distinctive architectural character.

Distinctive Features + Diverse Applications + Multitude of Benefits:

- Delivered to site ready-made for single-trade installation
- Concealed mounting in certain applications
- A selection of widths, configurations and mounting options

Attention to Detail:

- 20mm depth
- Maximum span: up to 3.0m depending on size of batten, location of building and local wind pressures.
- Designed, engineered and certified for incidental live load.

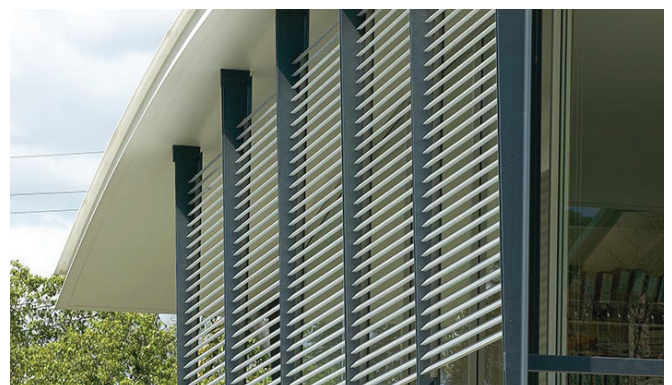

SLIM SUN SHADING OPTION



Thinking outside for inside performance

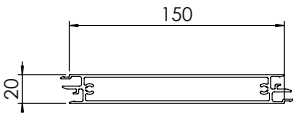
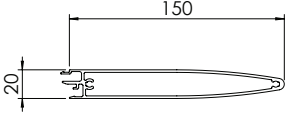
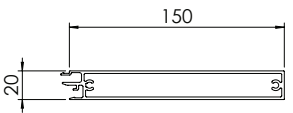
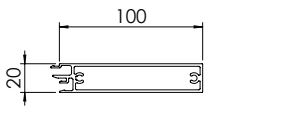
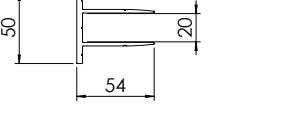

PROFILES

Render	Code	Description
	SCA-PANEL	150mm Panel
	SCA-BULLET	150mm Bullet
	SCA-150EP	150mm End Panel
	SCA-100EP	100mm End Panel
	SCA-CHAN	Mounting Channel

Typical Installation

1. Wall Mounting Channel

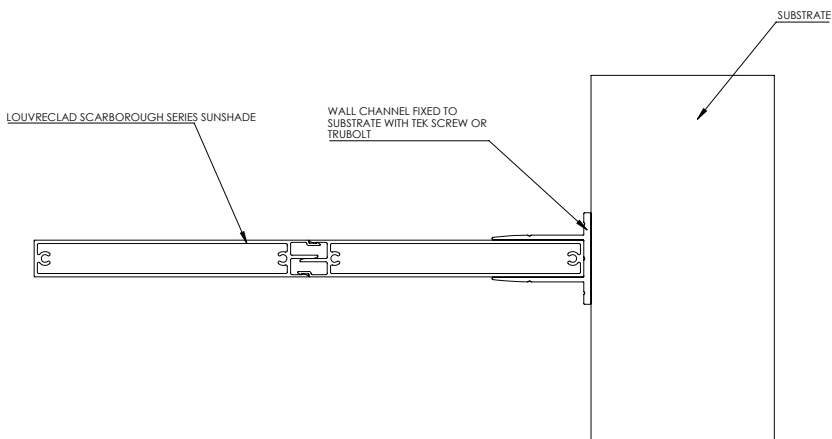

TYPICAL CONFIGURATIONS

Panel:

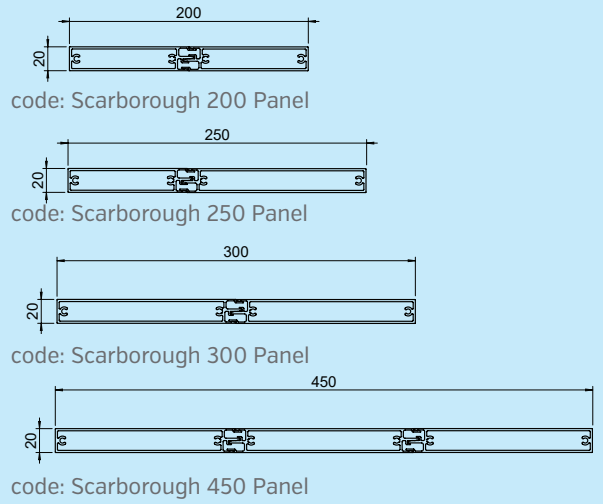

Bullet:

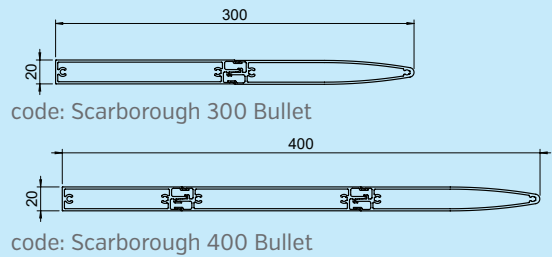

Ellipsoid:

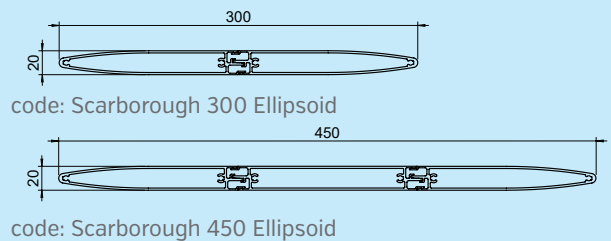

DRAFT SPECIFICATION

Screens will be Louvreclad Scarborough Series® base module plus 100mm or 150mm increments [state width] [Bullet/Panel/Ellipsoid]. Blades will be _____ [Operable/Fixed] if fixed [state pitch] mm pitch at [state angle]° angle.

Base Material & Finish

Screens will be manufactured in [powder coated/anodised] aluminium finish in [state colour]

Operation Method [if applicable]

The operation method will be [Electric Motor/Manual winder/other - choose method]

Control System [if applicable]

Automated Control will be by [specify sensors and control system]

Accessories [if applicable]

Screens will be fitted with [nominate options/accessories from the selection].

Installation and Mounting

Installation and mounting details will be designed in accordance with proprietary systems and recommendations as designed and manufactured by Louvreclad Pty. Ltd. Phone: 1300 165 678 Email: sales@louvreclad.com

Base Material Options

- Extruded Aluminium

Finishes Available

Choose from the following range of finishes:

- complete powder coated range
- complete anodised range

Specialised coatings are also available on request.

PROFILES

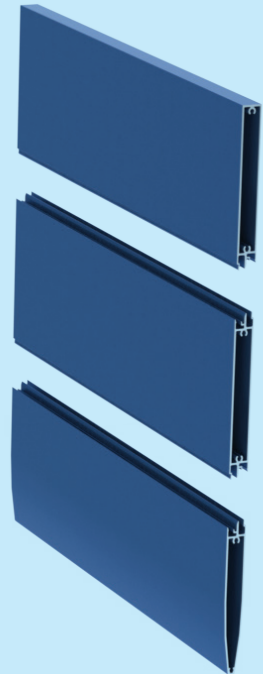



i WOULD YOU LIKE TO KNOW MORE?

If you have any questions about this product, or if you would like to speak to a member of our expert team about how we can tailor a solution for you, call: **1300 165 678** or visit: **louvreclad.com**