



SAB drain
water drainage systems

704 CAST IRON GRATED CHANNEL



The details that make the difference.....

CLASS D CAST IRON GRATED DRAINAGE CHANNEL

SABDrain 704 provides the ultimate desirability for design and functionality of any drainage channel available to the civil construction market. Due to the lightweight channel unit and high strength cast iron grate, the flexibility and durability of this product is able to satisfy the most demanding requirements placed upon it. This rated channel and grate has been designed for situations that require accessibility for heavy commercial vehicles as well as being able to cater for the needs of highway use. Each grate is equipped with an 8 point security fixing system, to keep it rattle free from vehicular movements and secure it from unauthorised access.

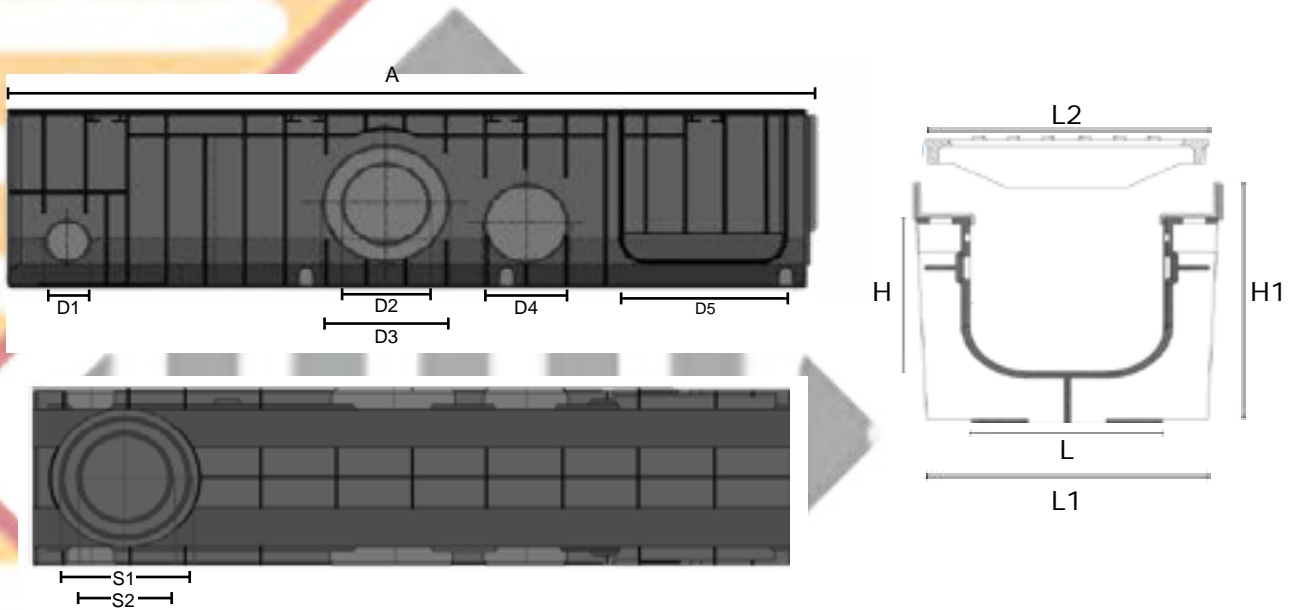

SABDRAIN 704															
CODE	L	H	L1	H1	L2	Drain cm ²	D1	D2	D3	D4	D5	S1	S2	A	KG
DR704100100	100	100	150	150	146	220	63	90	63	63	100	110	63	1000	11.3
DR704100150	100	150	150	200	146	220	63	110	63	110	100	110	63	1000	11.8
DR704150100	150	100	200	150	197	348	63	90	63	63	150	110	63	1000	14.5
DR704150150	150	150	200	200	197	348	63	110	63	110	150	110	63	1000	15.2
DR704200100	200	100	250	150	247	494	63	90	63	63	200	160	110	1000	17.4
DR704200150	200	150	250	200	247	494	63	110	63	90	200	160	110	1000	17.9
DR704200200	200	200	250	250	247	494	63	160	110	90	200	160	110	1000	18.4
DR704200250	200	250	250	300	247	494	63	160	110	90	200	160	110	1000	18.9
DR704200300	200	300	250	350	247	494	63	160	110	90	200	160	110	1000	19.4





SAB drain
water drainage systems

704 GRANDE CAST IRON GRATED CHANNEL

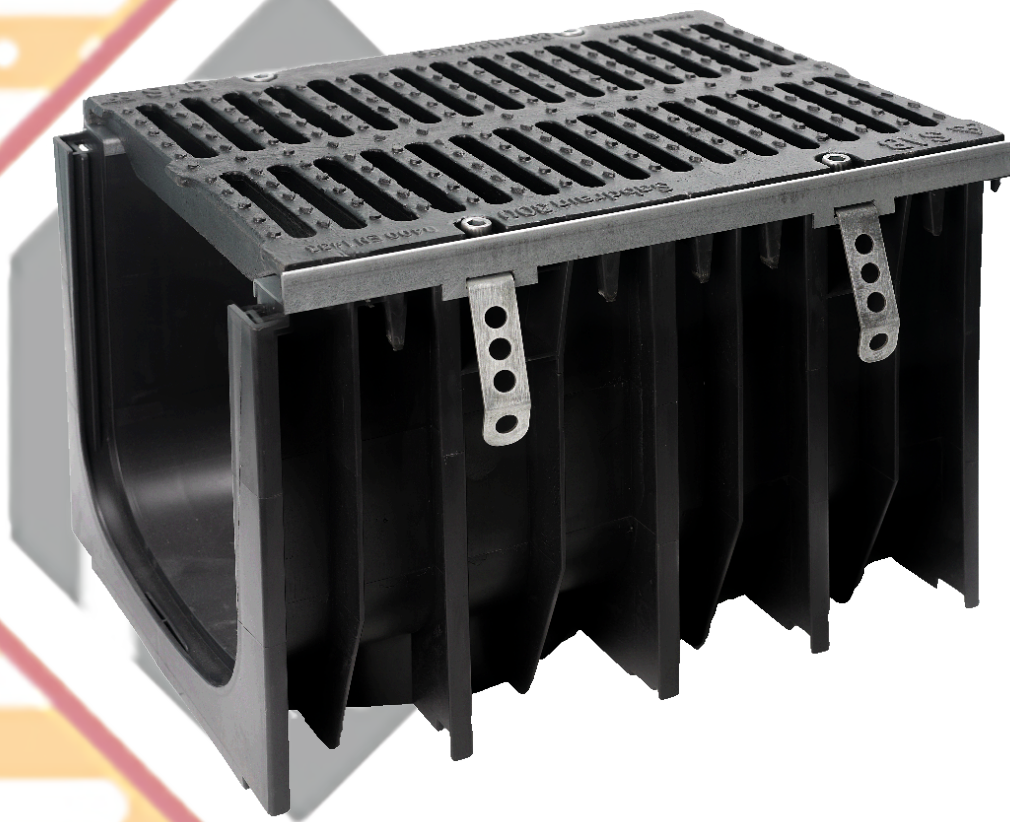

The details that make the difference.....

CLASS D CAST IRON GRATED DRAINAGE CHANNEL

SABdrain 704 grande is one of our largest channel and grate units available for ever increasing needs of the drainage market. While still being able to meet what is necessary to comply with the design requirements of class C & D Rating. This includes heavy commercial vehicles, roads & motorways. Each grate is equipped with a 4 point security fixing system to secure it from unauthorised access and keep it rattle free from vehicular movements along with steel side edging to give higher resistance to heavy loads.



C150



D210



Anti-Slip



Lockdown

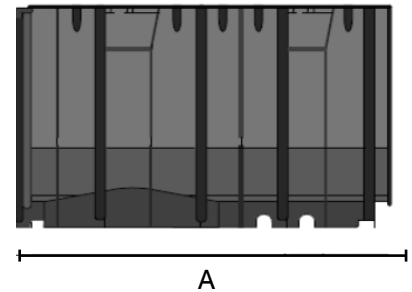
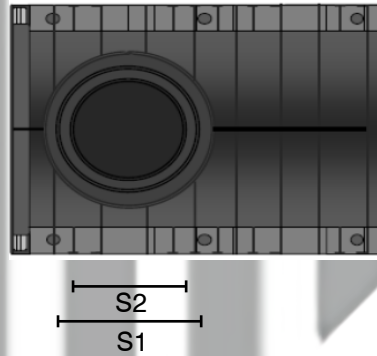
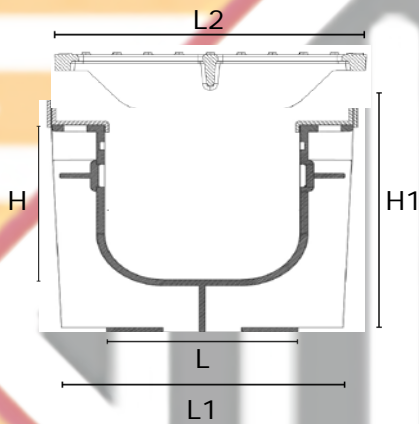

SABDRAIN 704 GRANDE

CODE	L	H	L1	H1	L2	Drain cm ²	S1	S2	A	KG
DR704300200	300	200	390	270	376	756	160	200	500	18.8
DR704300300	300	300	390	370	376	756	160	200	500	19.2





SAB drain
water drainage systems

705 CAST IRON GRATED CHANNEL

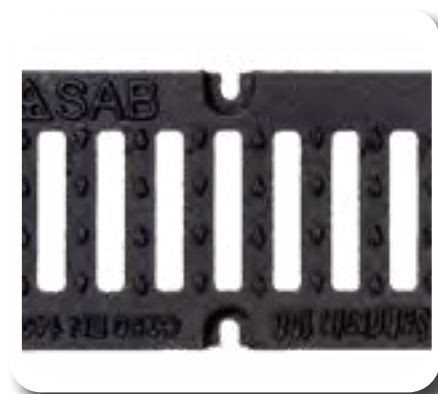

The details that make the difference.....

CLASS E CAST IRON DRAINAGE CHANNEL

SABDrain 705 provides the ultimate desirability for design and functionality of any drainage channel available to the civil construction market. Due to the lightweight channel unit and high strength cast iron grate, the flexibility and durability of this product is able to satisfy the most demanding requirements placed upon it. This rated channel and grate has been designed for situations that require accessibility for heavy commercial vehicles as well as being able to cater for the needs of highway use. Each grate is equipped with an 8 point security fixing system, to keep it rattle free from vehicular movements and secure it from unauthorised access.

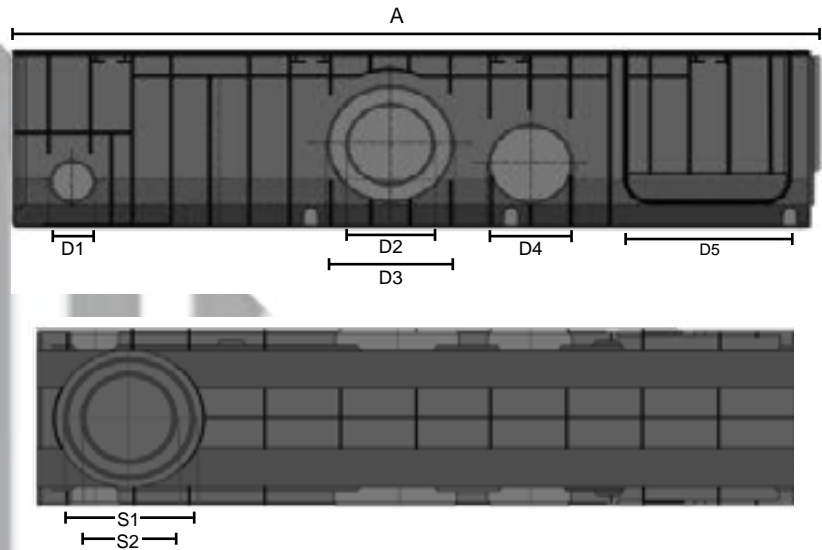
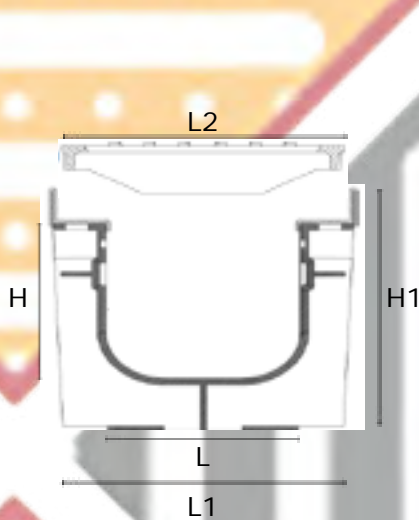

SABDRAIN 705															
CODE	L	H	L1	H1	L2	Drain cm ²	D1	D2	D3	D4	D5	S1	S2	A	KG
DR705100100	100	100	150	150	146	248	63	90	63	63	100	110	63	1000	13.8
DR705100150	100	150	150	200	146	248	63	110	63	110	100	110	63	1000	14.3
DR705150100	150	100	200	150	146	248	63	90	63	63	150	110	63	1000	17.6
DR705150150	150	150	200	200	197	334	63	110	63	110	150	110	63	1000	18.3
DR705200100	200	100	250	150	247	494	63	90	63	63	200	160	110	1000	21.3
DR705200150	200	150	250	200	247	494	63	110	63	90	200	160	110	1000	21.8
DR705200200	200	200	250	250	247	494	63	160	110	90	200	160	110	1000	22.3
DR705200250	200	250	250	300	247	494	63	160	110	90	200	160	110	1000	22.8
DR705200300	200	300	250	350	247	494	63	160	110	90	200	160	110	1000	23.3





SAB drain
water drainage systems

705 GRANDE CAST IRON GRATED CHANNEL



The details that make the difference.....

CLASS E CAST IRON DRAINAGE CHANNEL

SABDrain 705 Grande heavy duty drainage channel & grates are the largest units available in a 300mm or 500mm width. The drain is equipped with steel support edging to guarantee higher performance for heavy loads and high traffic as well as industrial areas using forklift vehicles. This has a classification of class E rating. This high strength cast iron grate is equipped with 4 point security fixings system to keep it rattle free from vehicular movements and secure from unauthorised access.



Class C



Class D



Class E



Anti-Slip



Lockdown

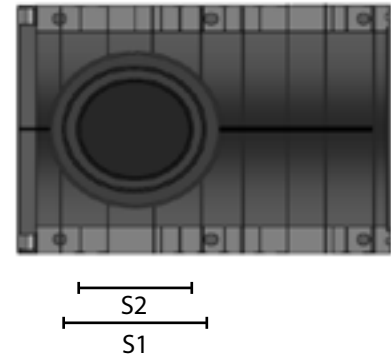
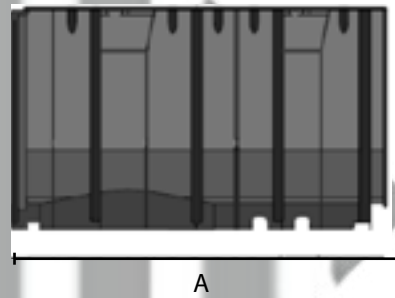
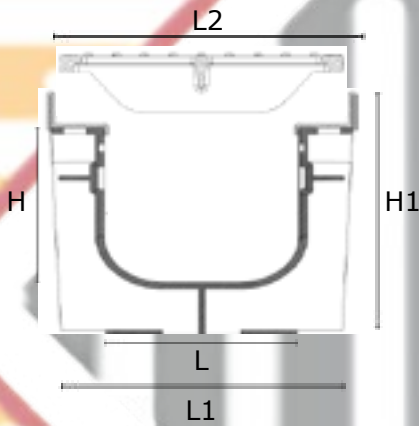

SABDRAIN 705 GRANDE										
CODE	L	H	L1	H1	L2	Drain cm ²	S1	S2	A	KG
DR705300200	300	200	390	270	376	756	160	200	500	23.4
DR705300300	300	300	390	370	376	756	160	200	500	23.8
DR705500500	500	500	595	560	580	1070	160	200	500	45





SAB drain
water drainage systems

706 CAST IRON GRATED CHANNEL

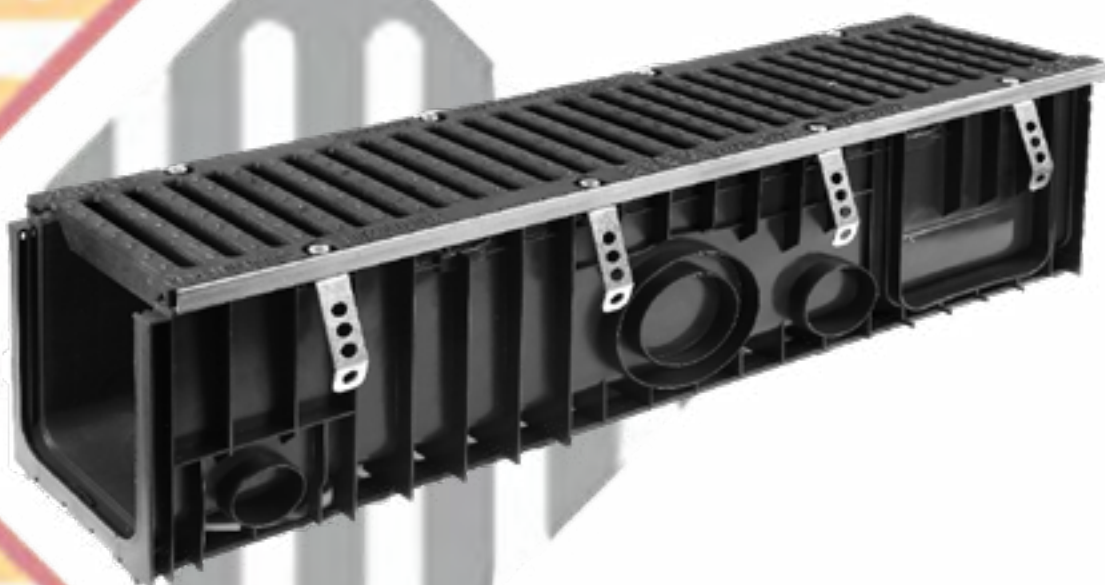

The details that make the difference.....

CLASS G POLYPROPYLENE DRAINAGE CHANNEL

SABDrain 706 is a heavy duty cast iron grated channel which comes with steel support edging to guarantee higher performance for heavy loads and high wheeled traffic up to the class G rating. This includes aircraft traffic, loading docks, container terminals, military and all hard wheeled vehicles. This high strength cast iron grate is equipped with an 8 point security fixing system to keep it rattle free from vehicular movements and secure from unauthorised access.

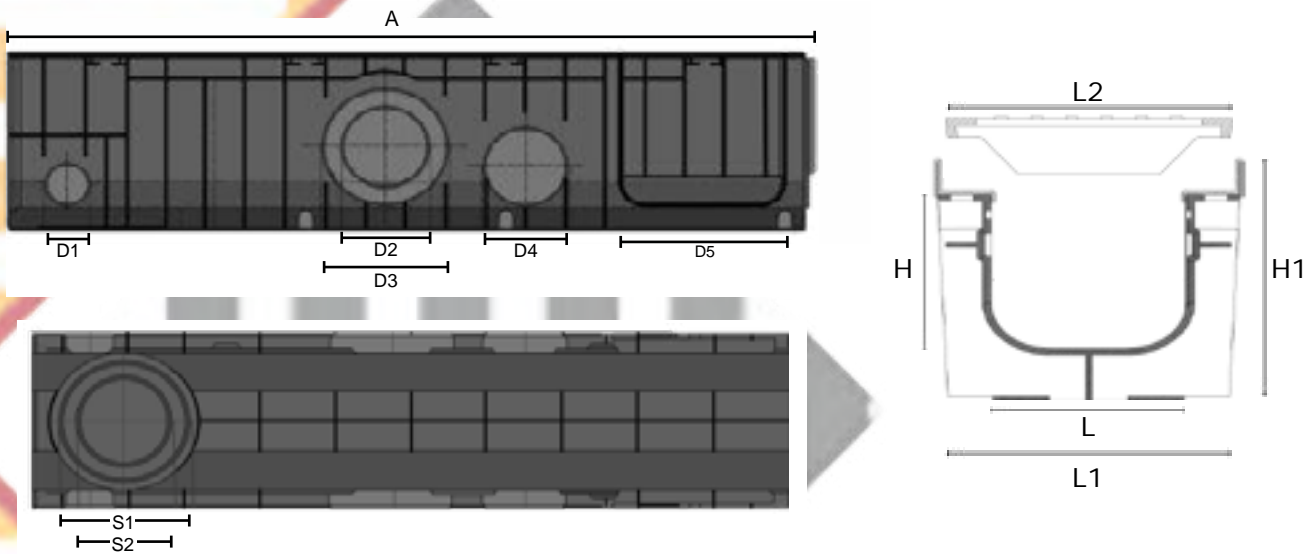
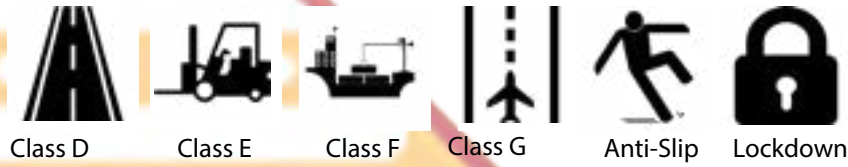

SABDRAIN 706															
CODE	L	H	L1	H1	L2	Drain cm ²	D1	D2	D3	D4	D5	S1	S2	A	KG
DR706100100	100	100	150	150	147	220	63	90	63	63	100	110	63	1000	16.2
DR706100150	100	150	150	200	147	220	63	110	63	110	100	110	63	1000	16.7
DR706150100	150	100	200	150	197	348	63	90	63	63	150	110	63	1000	22.6
DR706150150	150	150	200	200	197	348	63	110	63	110	150	110	63	1000	23.3
DR706200100	200	100	250	150	247	476	63	90	63	63	200	160	110	1000	33.1
DR706200150	200	150	250	200	247	476	63	110	63	90	200	160	110	1000	33.6
DR706200200	200	200	250	250	247	476	63	160	110	90	200	160	110	1000	34.1
DR706200250	200	250	250	300	247	476	63	160	110	90	200	160	110	1000	34.6
DR706200300	200	300	250	350	247	476	63	160	110	90	200	160	110	1000	35.1





SABdrain
water drainage systems

706 GRANDE CAST IRON GRATED CHANNEL

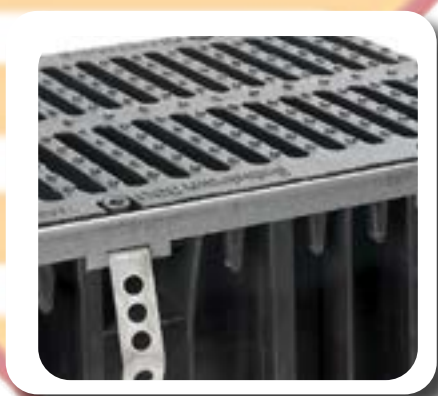

The details that make the difference.....

CLASS G CAST IRON GRATED DRAINAGE CHANNEL

SABDrain 706 Grande is the largest channel, available in both 300 & 500mm widths. This comes with steel support edging to guarantee higher performance for heavy loads and high wheeled traffic up to the class G rating. This includes aircraft traffic, loading docks, containers terminals, military and all hard wheeled vehicles. This high strength cast iron grate is equipped with an 4 point security fixing system to keep it rattle free from vehicular movements and secure from unauthorised access.

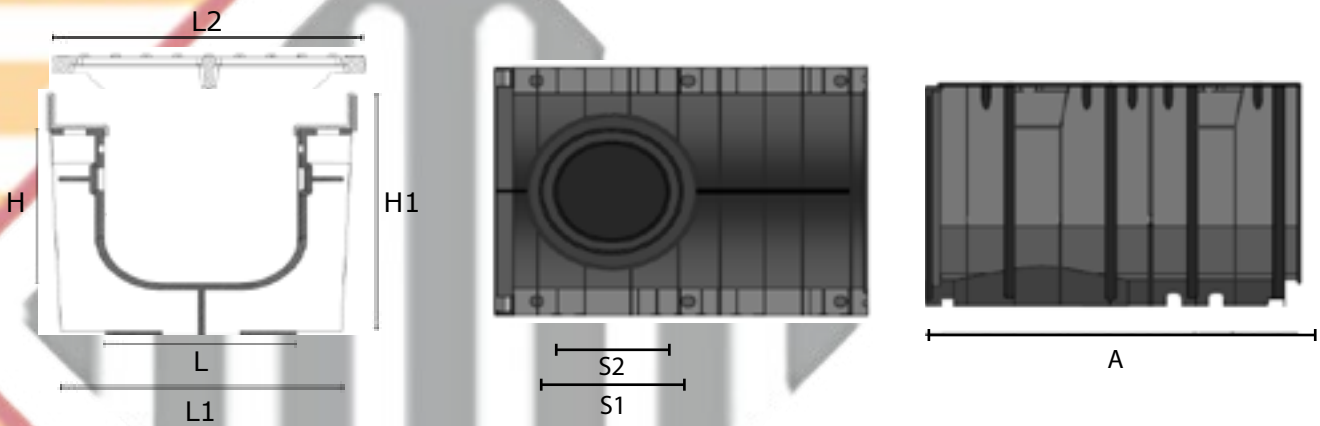
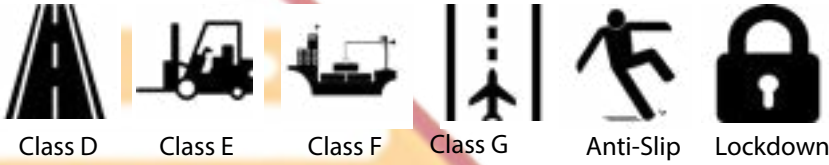

SABDRAIN 706 300

CODE	L	H	L1	H1	L2	Drain cm ²	S1	S2	A	KG
DR706300200	300	200	390	270	376	618	160	200	500	32.2
DR706300300	300	300	390	370	376	618	160	200	500	32.6
DR706500500	500	500	595	560	580	1070	160	200	500	56.7





SAB drain
water drainage systems

707 CAST IRON HEEL GUARD GRATED CHANNEL

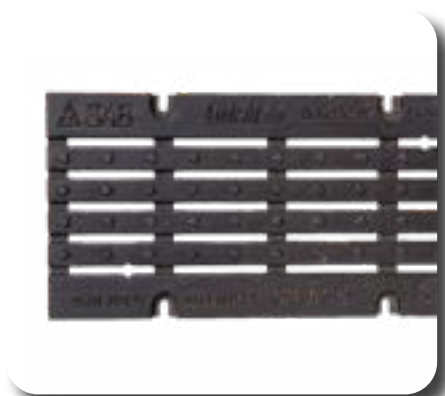

The details that make the difference.....

CLASS D CAST IRON HEEL GUARD DRAINAGE CHANNEL

SABdrain 707 provides the ultimate desirability for design and functionality of any drainage channel available to the civil construction market. From its lightweight channel unit to the high strength heel guard cast iron grate, the flexibility and durability of this product is able to offer the most demanding requirements placed upon it. This rated channel and grate has been designed to withstand fast heavy moving vehicles used in commercial areas along with motorways/highways meeting the Class D requirements. Each grate is equipped with 4 point security fixings system to keep this rattle free from vehicular movements and secured from unauthorised access.



Class C



Class D



Heel Guard



Anti-Slip



Lockdown



Disability Compliant

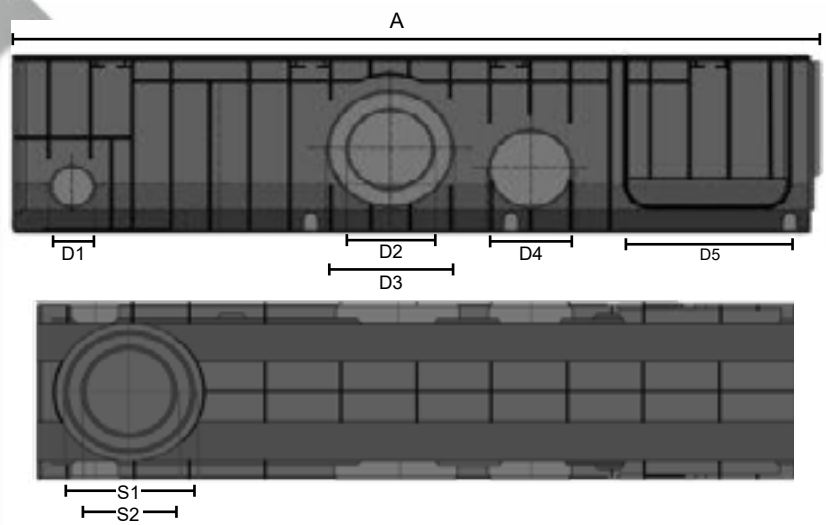
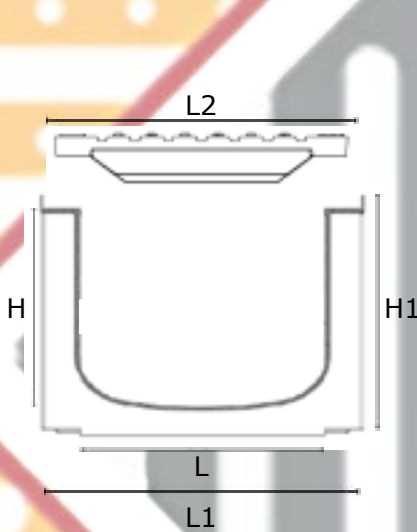

SABDRAIN 707

CODE	L	H	L1	H1	L2	Drain cm ²	D1	D2	D3	D4	D5	S1	S2	A	KG
DR707100100	100	100	150	150	147	81	63	90	63	63	100	110	63	1000	16.8
DR707100150	100	150	150	200	147	81	63	110	63	110	100	110	63	1000	17.3
DR707150100	150	100	200	150	197	137	63	90	63	63	150	110	63	1000	21.8
DR707150150	150	150	200	200	197	137	63	110	63	110	150	110	63	1000	22.5
DR707200100	200	100	250	150	247	191	63	90	63	63	200	160	110	1000	27.1
DR707200150	200	150	250	200	247	191	63	110	63	90	200	160	110	1000	27.6
DR707200200	200	200	250	250	247	191	63	160	110	90	200	160	110	1000	28.1
DR707200250	200	250	250	300	247	191	63	160	110	90	200	160	110	1000	28.6
DR707200300	200	300	250	350	247	191	63	160	110	90	200	160	110	1000	29.1





SABdrain
water drainage systems

707 GRANDE CAST IRON GRATED CHANNEL



The details that make the difference.....

CLASS D POLYPROPYLENE DRAINAGE CHANNEL

SABdrain 707 grande provides the ultimate desirability for design and functionality of any drainage channel available to the civil construction market. From its lightweight channel unit to the high strength heel guard cast iron grate, the flexibility and durability of this product is able to offer the most demanding requirements placed upon it. This rated channel and grate has been design to withstand fast heavy moving vehicles used in commercial areas along with motorways/highways meeting the Class D requirements. Each grate is equipped with 4 point security fixings system to keep this rattle free from vehicular movements and secured from unauthorised access.

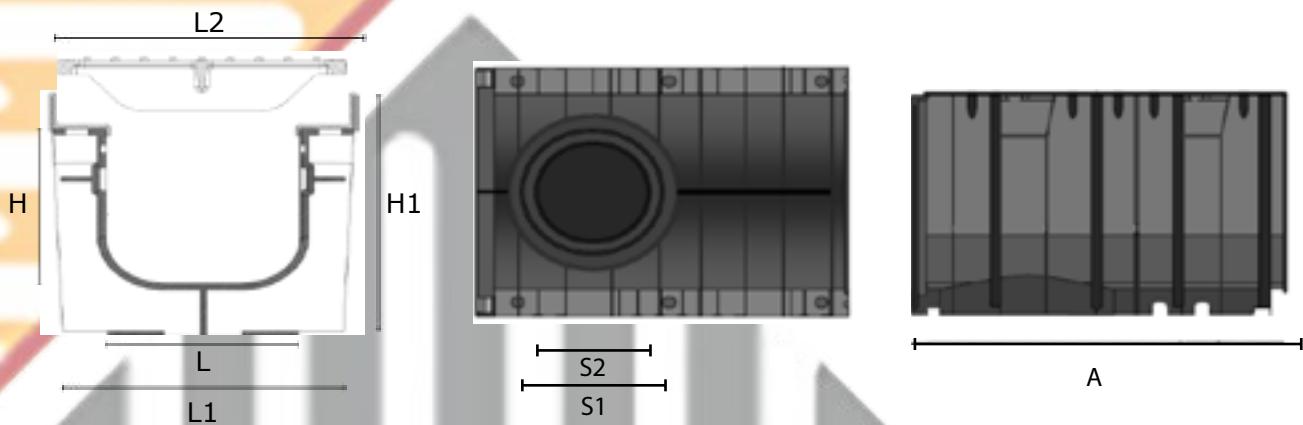

SABDRAIN 707 GRANDE										
CODE	L	H	L1	H1	L2	Drain cm ²	S1	S2	A	KG
DR707300200	300	200	390	270	376	273	160	200	500	20.5
DR707300300	300	300	390	370	376	273	160	200	500	20.5

