

Kemlan C24

The hottest thing in wood heater technology



One of the cleanest burning, most efficient wood heaters in Australia.



C24



C24 CLASSIC

The Kemlan C24 has been tested for emissions to an impressive 1.4gms/kg of hardwood (the Australian Standard is 4gms/kg), with an overall efficiency of 68%, making the C24 one of the most efficient wood heaters around.

So when you are heating your home with a C24 you know it's good for the environment.

The Kemlan C24 will be a stylish focal point in your home.

The C24 is easy to use. It has one slide control, which is simple to adjust. This single touch control regulates the preheated primary airwash system and a sophisticated 24-point secondary air induction system. Clean burning technology means you have the flexibility to regulate your comfort level by adjusting the flame pattern and burn time of the fire.

Kemlan heaters burn safely, with the flame behind a large, strong glass ceramic viewing area. The ceramic glass will remain clean throughout the life of the fire by an advanced airwash system designed within the firebox. The flames are so natural, the glass so clean, that viewing is actually more satisfying than an open fireplace.

The fully shielded firebox incorporates a natural convection system. This system allows warmth to circulate throughout your home. An optional 3 speed fan is available to increase circulation by fan forced convection.

The robust cast iron top features a large flat cooking area. Steady, controllable heat will allow the cooktop to reach temperatures up to and around 200°C, perfect for cooking, warming or steaming.

The C24 incorporates superheat ceramic baffle technology. Modern day ceramic refractory, similar to that used on space ships has the ability to eliminate heat loss up the flue and retain heat in the firebox, ensuring extra heat in the room. Secondary air is

added just below the baffle. Fumes are burnt due to the high ignition temperature, allowing a remarkable average of only 1.4gms/kg of wood burnt. The allowable Australian standard is 4.0gms/kg. The efficiencies in past designs have been compromised, but in the case of the C24 efficiencies are generally 8-10% more efficient than most other wood heaters on the market.

The C24 complies with AS/NZS 3869 for strength and durability and AS/NZS 2918 for safety clearances to heat sensitive materials.

Kemlan offers you flexibility in your choice of colours. The C24 is available in the standard colour, Metallic Black, or special colours. These are Charcoal and Metallic Brown. Consult your local distributor for the pricing details and availability of the colour you choose.

Kemlan is a wholly owned and operated Australian Company established in 1969, specialising in the design and manufacture of quality wood heating appliances. Relax in comfort with the attractive Kemlan C24 warming your home.

Super clean

- Environmentally friendly
- Complies to AS/NZS 4012/4013 for clean emission output
- Preheated primary airwash system ensures a clean view of the fire
- Fully controllable 24-point secondary air induction system
- Remarkable 1.4gms/kg emissions

Simple

- Trouble-free operation
- One easy slide control for steady controllable heat
- No levers, rods or dampers
- Easy to light

Safe

- Tested to AS/NZS 2918 for safety clearances
- Fully shielded convection firebox
- Large ceramic glass viewing area

Stylish

- The C24 Classic offers style, the convenience of wood storage and easy loading

Efficient

- An impressive 68% efficiency
- Overnight burn
- Natural convection system
- Optional 3-speed fan
- Large cooktop

Robust

- Tested to AS/NZS 3869 for design durability
- 6mm welded steel firebox
- Firebrick lined floor
- Superheat ceramic baffle for maximum efficiency
- Heavy duty door hinges
- Serviceable door handle assembly
- Stainless steel glass holder

Specifications

Overall Dimensions

A	B	C	D
Width 670mm	Height 710mm	Depth 550mm	Depth (centre of flue to back) 170mm

Minimum Clearance to Heat Sensitive Materials and Minimum Floor Protector Requirements

A	B	C	D	E	F	G	H	I	J
150	450	225	320	750	450	1000	1000	1225	500

Dimensions above are in millimetres.

One 900mm length of heatshield must be fitted to the flue to achieve clearances to heat sensitive materials (measurements A B C D E F).

A floor protector is required where the floor is heat sensitive. Thickness to be a minimum of 6mm heat resistant material and must extend 350mm in front and 200mm to each side of the firebox opening (measurements G H I J).

Glass viewing area 445mm wide x 215mm high
Flue pipe 150mm Ø – top ext
Cooktop area 250mm wide x 200mm deep
Shipping weight 198kg

All dimensions shown are approximate. Check all dimensions accurately before installation. Before installation refer to the installation instructions.

In line with our policy of continuous improvement, we reserve the right to alter specifications without notice.

Construction

- 8-10mm cast iron top convection chamber; base and legs
- 6mm heavy duty steel firebox – fully welded 25mm thick firebrick lined floor

Performance

- Heating capacity – 220-280m² (23-30 squares)
- Peak heat output – 16kW
- Average emission output – 1.4gms/kg
- Overall efficiency – 68%

Burn Rate

	HIGH	MEDIUM	LOW
Average heat output (kW)	11.6	9.3	7.0
Fuel consumption (kg/hr)	3.4	2.6	1.8

Tested by HRL, Report No. HCMG/06/009

Heating capacity of this appliance is given as a guide only and may vary depending on the climate zone and type of dwelling (floor plan and degree of insulation). Consult your local authorised distributor to determine realistic expectations for your home.

Heat output, fuel consumption and efficiency of this appliance, is dependent on the moisture content, size, loading geometry and the type of hardwood used.

The appliance complies to the safety standards AS/NZS 2918 and AS/NZS 3869. When in use some parts may become hot. A suitable fireguard is recommended where the very young, elderly or infirm are concerned.

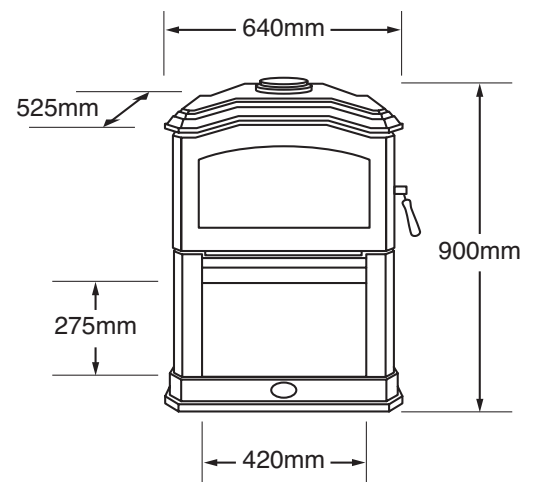
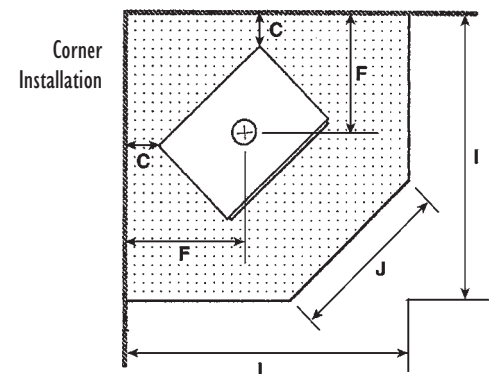
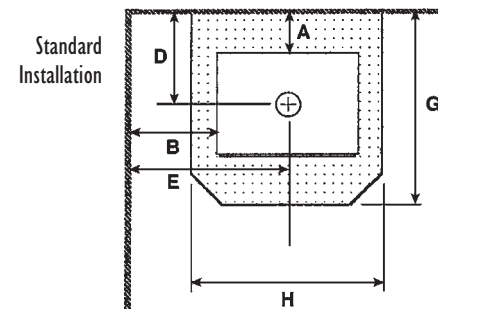
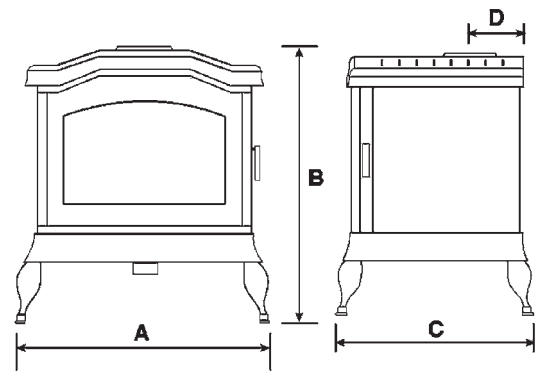

Call into your nearest Jetmaster showroom

NSW 10 Martin Ave, Arncliffe 02 9597 7222
 167 Eastern Valley Way, Castlecrag 02 9958 1777
 3/10 Salisbury Rd, Castle Hill 02 9680 7279
 17A Lyell St, Mittagong 02 4872 2234
 334 Bruncker Rd, Adamstown, Newcastle 02 4952 9299

QLD 59 Pineapple St, Zillmere 07 3263 4955
SA 19 Marlow Rd, Keswick, Adelaide 08 8371 1222
VIC 444 Swan St, Victoria 03 9429 5573
WA 277 Lord St, East Perth 08 9228 2600

www.jetmaster.com.au