

# SecuraGate

## Industrial Gates + Perimeter Security Handbook



Holistic guide to perimeter security | Vehicular access control

# The Leda Advantage

☎ 1300 780 450

Leda is the Australian market leader in the design and manufacture of physical security and vehicular access control products. Leda products have been installed across Australia to protect many of the nation's icons, government buildings and utilities, defence bases, and on numerous other projects where reliable high security equipment is required.



## The Leda Advantage

- Innovative products
- Stylish contemporary designs
- High vandal resistance
- Reliable and low maintenance
- Cost efficient
- Superior installation methods
- Unparalleled technical advice with product choice and specification
- Independently-tested, crash-rated barriers



Leda commenced operations in 1994 and has its main manufacturing plant located at Tuggerah NSW, about 90 kilometres north of Sydney. In early 2012 Leda opened its own factory and offices in Ningbo China, to service sales in that country as well as catering for the North America and European markets.

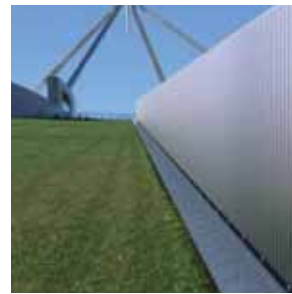

## Quality

As part of its policy of ongoing improvement, Leda works continually to advance the effectiveness and efficiency of all its products. When selecting or specifying from within this handbook, it is advisable to consult directly with Leda to ensure that specifications have not been altered. Leda can also advise on the suitability of your gate or barrier selection for the proposed application.

## Service

Every Leda client is guaranteed unrivalled service, advice and technical support. Products are distributed and supported through branch offices or distributors throughout Australia and New Zealand.



## Warranty

All Leda products carry a full comprehensive 12 month warranty. Optional warranty extensions are also available if and when Preventative Maintenance Contracts (PMC) are entered into.

## Materials and Finishes

Most Leda products are available in a pre-primed painted finish or galvanised mild steel. Leda utilises its own robotic cutting / welding and powder coating equipment to ensure a consistent, high quality finish to all of its products.



## Industrial Gates & Perimeter Security Handbook.

Copyright © Leda Security Products Pty Ltd 2013. All rights reserved. No part of this work may be produced or utilised in any form or by any means, electronic or mechanical, including photocopying, recording or in any information storage or retrieval system, without the prior written permission of Leda Security Products Pty Ltd.

1300 780 450



**General**

Leaders in perimeter security 2  
 Engineering 3  
 Specification to commissioning 4  
 Leda product range overview 6  
 Product applications 8  
 Security specifications 10  
 Security classes 12

**Gates**

The Leda gate range at a glance 14  
 Features of Leda gate technology 16  
 A Leda gate for every application 18  
     Track Gates 20  
     Cantilever Gates 30  
     Swing Gates 40  
     Bi-fold Gates 46  
     Boom Gates 52  
         Vertical Boom 54  
         Swing Boom 68  
         Sliding Boom 72  
 Options & Accessories 76  
 Safety 82  
 Signage 83  
 Product Checklist 86  
 Rendering Service 87  
 Installation Details 88  
 Transportation 92  
 Service & Maintenance 93

**Barriers**

Vehicle Barriers 94  
 Road Blockers 100  
 Tyre Spikes 102  
 Pre-cast Concrete Barriers 106  
 Other Barrier Products 111

**Pedestrian Access**

Full Height Turnstiles 114  
 Turnstile Roofs 126  
 Turnstile Options 127  
 Half Height Turnstiles 128  
 Gates & Doors 136

**Fencing**

Range 142  
 Premier / Palisade 143  
 Redfern / Sports 144  
 Bastille / Securamesh 145  
 Securamesh High Security / Bristorm 146  
 Impact Fence 147  
 FAXP Fence 148  
 Intruder Detection System 149  
 Retractable Fence 150  
 Retractable Gate 151  
 Rubbish Enclosures 152

**Index**

Product Codes 153



## Intro > Leaders in Perimeter Security

☎ 1300 780 450



As Australia's leading specialist in perimeter security solutions and vehicular traffic control systems, Leda can offer a complete range of integrated perimeter security solutions – comprising industrial and security gates, boom gates, road blockers, tyre spikes, turnstiles, barriers and fences, as well as over 500 models of Securapost® bollards.

For the complete range of Securapost bollards refer to Leda's *Architectural & Security Bollards Handbook*.

Leda offers:

- Holistic solutions
- Standard product range
- Standards compliance
- Quick turnaround
- Local production and parts support
- Minimal downtime

Designing perimeter security solutions requires an holistic approach. This is the fundamental undertaking by Leda Security in recommendations to clients, consulting organisations and business partners.





1300 780 450

One of Leda's strengths is its vast engineering experience in designing site-specific solutions, making it the 'go to' gate manufacturer for complex or difficult projects.

From the initial site survey and audit, Leda will provide the necessary technical information and options to allow clients to make an informed decision.



**Design**

If required, Leda can provide detailed renderings to show how the installation will look upon completion – a useful service, and one to take advantage of when a committee or management board need to make the decision.

**Production**

Prior to manufacture, a full set of working drawings will be submitted for approval eliminating any misunderstanding of the project's extent of work.



**Installation**

A Leda project manager will be appointed in advance of the installation to plan and supervise stages of production and ensure a smooth, professional install and commissioning of the equipment.



**Service and maintenance**

Leda technicians will make recommendations on the required service and maintenance program required for your equipment based on expected usage. An agreed Preventative Maintenance Contract (PMC) will then be implemented to ensure the equipment provides a maximum service life.

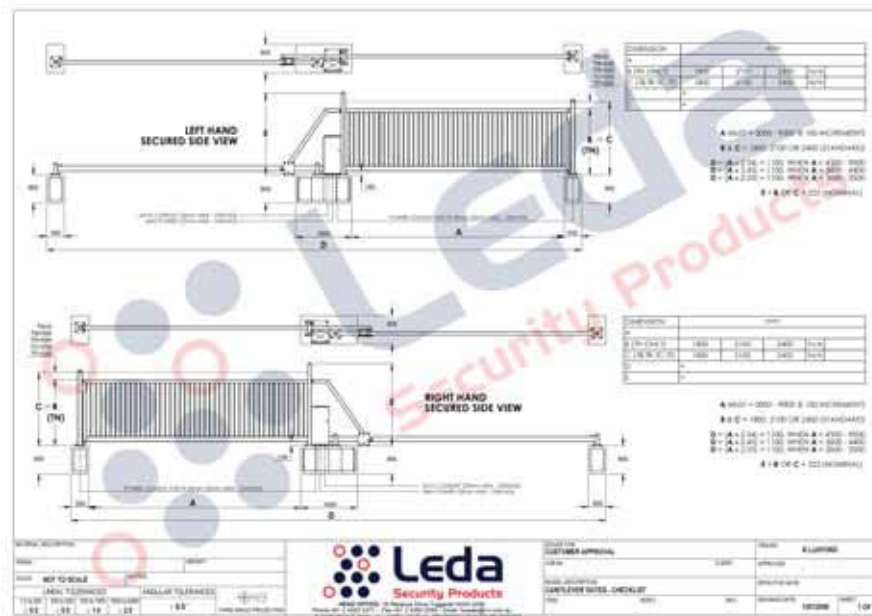

**Warranty**

A comprehensive 12 months' warranty (parts and equipment) commences from date of supply (or commissioning if Leda installs). This will be extended to 24 months provided Leda's recommended PMC is entered into within 6 months of the equipment being installed.

<b>Intro</b>	<b>2</b>
<b>Gates</b>	<b>14</b>
Track	20
Cantilever	30
Swing	40
Bi-fold	46
Boom	52
Options	76
General	82
<b>Barriers</b>	<b>94</b>
Blockers	100
Tyre Spikes	102
Pre-cast	106
Other	111
<b>Pedestrian</b>	<b>114</b>
Turnstiles	114
Gates & Doors	136
<b>Fencing</b>	<b>142</b>
<b>Code Index</b>	<b>153</b>

# Intro > Specification to Commissioning

☎ 1300 780 450

In selecting Leda, you are selecting an Australian owned company that manufactures its gates and security products in Australia under strict OH&S and quality controlled programs. Leda's strengths lie in its ability to offer comprehensive solutions through an extensive support structure comprising local sales teams and experienced engineering and design staff backed by modern manufacturing facilities and unparalleled installation and maintenance support.

You will be provided with:

- A check list to assure you select the appropriate accessories and consider the operational performance you will require of your gate or road barrier.
- Comprehensive working drawings allowing your staff to sign-off on before commencement of production.
- Structurally designed footing details.
- An operations manual including specifications, drawings, spare parts list and recommended servicing information.



## Double your warranty period

After successful commissioning of your gate, and normally within a month, you'll receive an after-sales service letter containing information on suggested servicing of your equipment and details of various Preventative Maintenance Programs available. If you elect to adopt one of these Programs Leda will double your warranty period from 12 months to 24 months.

## Specification

At the early stages of any project, Leda can provide advice and engineering documentation, including written specifications for product, and CAD drawings for site plans.

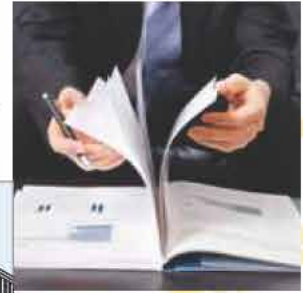
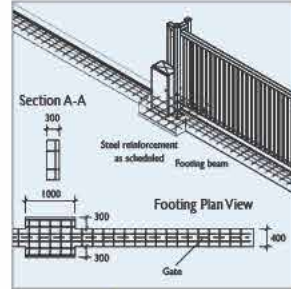

## Service

Service is a critical component to the long-term operation of all Leda equipment. Preventative maintenance programs are available to ensure all products continue to perform reliably and efficiently and it is highly recommended that a service and maintenance agreement be taken out for all automated or mechanically moving products.



## Installation

The construction industry is learning the benefit of suppliers able to project manage as it is more critical than price. Incompetent sub contractors will end up requiring more management which wipes out any perceived price advantage. Having Leda Install ensures that there are no excuses for poor commissioning.





☎ 1300 780 450



**Design**

Ongoing research and development provides the products and technical advice needed for real perimeter security solutions. Products are 3D modelled, and drawn for installation when required. Shop drawings are submitted for approval prior to manufacturing. Engineering staff includes both mechanical and electrical with close support from civil engineering sub-contractors.



**Testing**

Leda undertakes ongoing Impact testing programs to confirm design and engineering specifications. From the test data, computer-modelling of the expected impact ratings can be carried out for both product and footing designs.

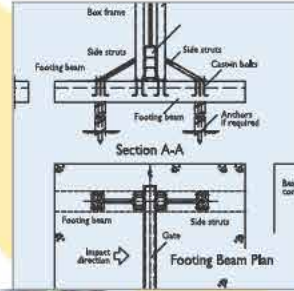

**Engineering**

Leda not only engineers the gates, but has developed a number of footing options that are designed to significantly reduce installation times and costs. This technology has been developed by Leda's engineers and further demonstrates Leda's reputation as the industry leader.

**Manufacturing**

Leda's modern 6000m<sup>2</sup> manufacturing facility is located at Tuggerah NSW (90km north of Sydney). Leda's internal manufacturing processes use MRP (Manufacturing Resource Planning) which also enables an effective QA system. To gain a deeper understanding of Leda's manufacturing capabilities, prearranged tours of the facility are welcome.



<b>Intro</b>	<b>2</b>
<b>Gates</b>	<b>14</b>
Track	20
Cantilever	30
Swing	40
Bi-fold	46
Boom	52
Options	76
General	82
<b>Barriers</b>	<b>94</b>
Blockers	100
Tyre Spikes	102
Pre-cast	106
Other	111
<b>Pedestrian</b>	<b>114</b>
Turnstiles	114
Gates & Doors	136
<b>Fencing</b>	<b>142</b>
<b>Code Index</b>	<b>153</b>



# Intro > Leda product range overview

☎ 1300 780 450

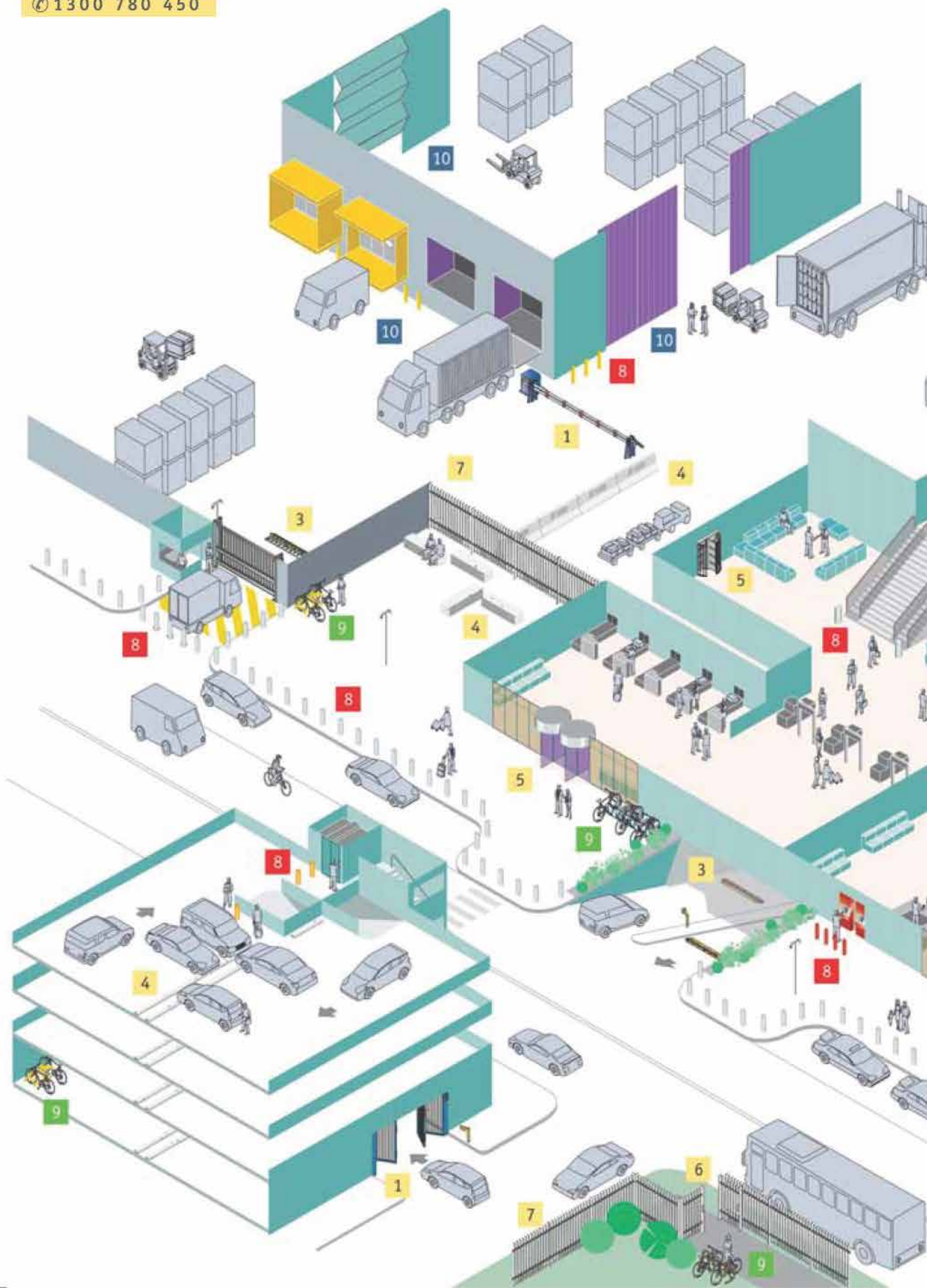

# Intro > Leda product range overview

☎ 1300 780 450

-  **8** **Bollards**  
*Refer Architectural & Security Bollards Handbook*
-  **9** **Bicycle Security**  
*Refer Bicycle Parking & Security Handbook*
-  **10** **Industrial Doors & Loading Docks**  
*Refer Doors & Loading Dock Products Handbook*

-  **1** **Gates**
-  **2** **Vehicle Barriers**
-  **3** **Tyre Spikes**
-  **4** **Pre-cast Barriers**
-  **5** **Turnstiles**
-  **6** **Pedestrian Gates**
-  **7** **Fencing**



<b>Intro</b>	<b>2</b>
<b>Gates</b>	<b>14</b>
Track	20
Cantilever	30
Swing	40
Bi-fold	46
Boom	52
Options	76
General	82
<b>Barriers</b>	<b>94</b>
Blockers	100
Tyre Spikes	102
Pre-cast	106
Other	111
<b>Pedestrian</b>	<b>114</b>
Turnstiles	114
Gates & Doors	136
<b>Fencing</b>	<b>142</b>
<b>Code Index</b>	<b>153</b>



# Intro > Product applications

☎ 1300 780 450

The Leda range of perimeter gates and security products can be used individually or in combination, depending on either the security required or the threat level.

For high security applications or critical infrastructure sites, Leda engineers will assist in designing a solution and tailoring it to site conditions.

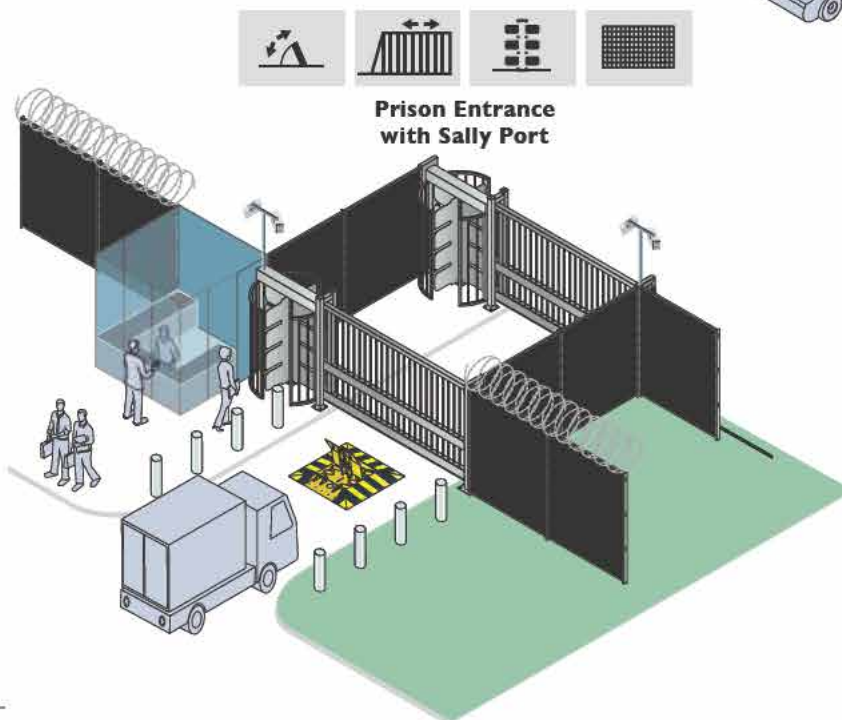
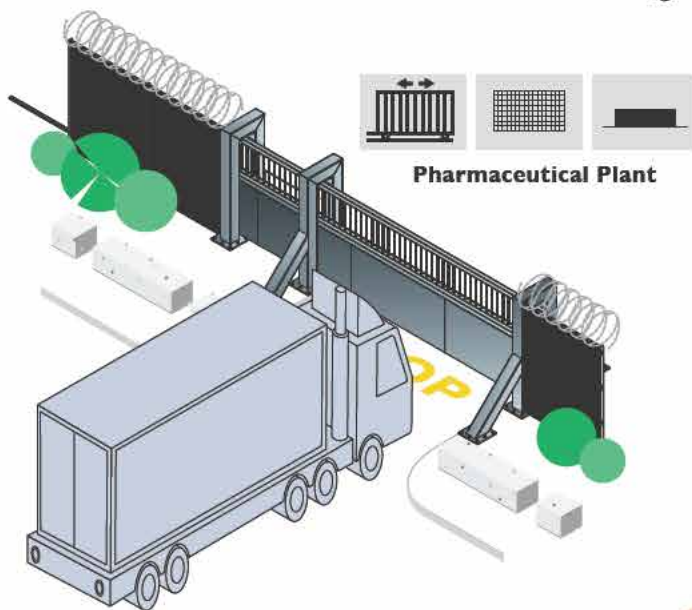
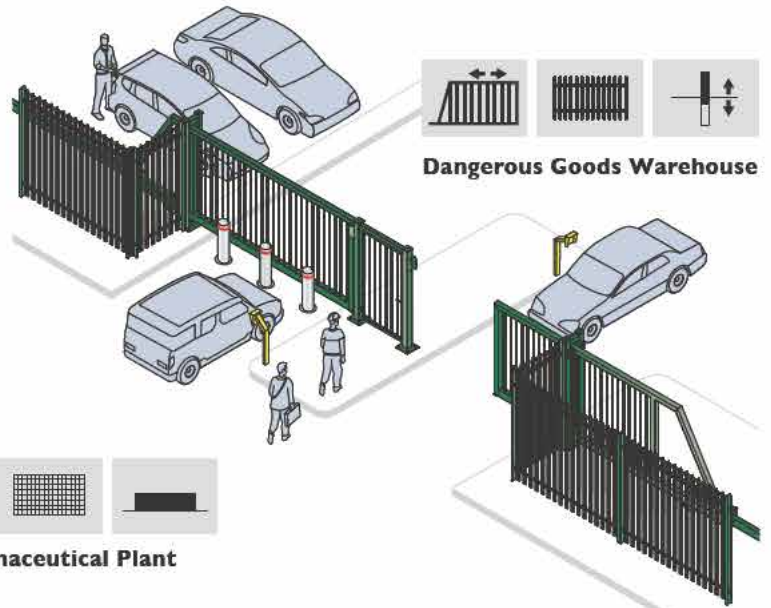



☎ 1300 780 450



Government or Embassy Offices

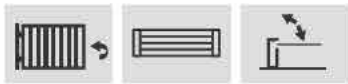
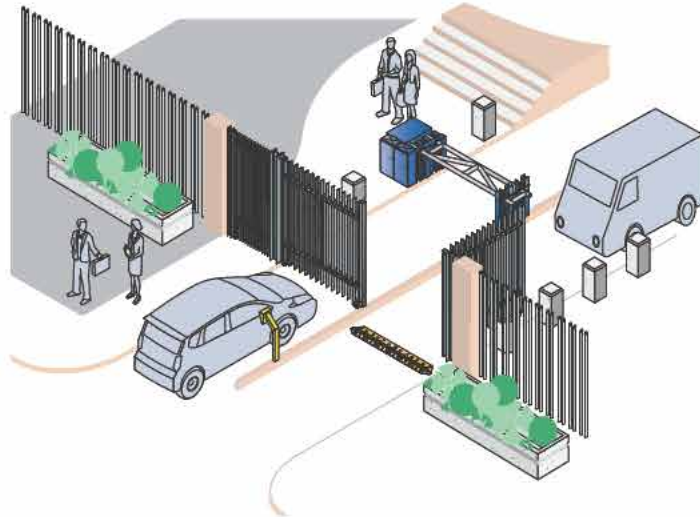

Government or Military Compound

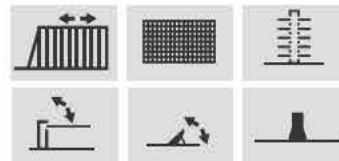
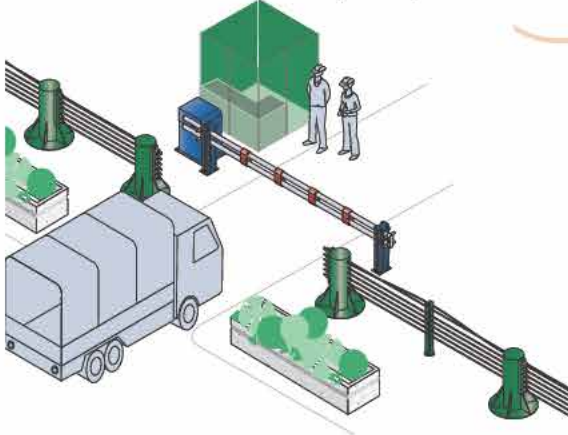

Seaport Container Terminal

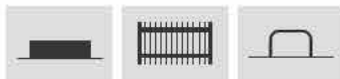
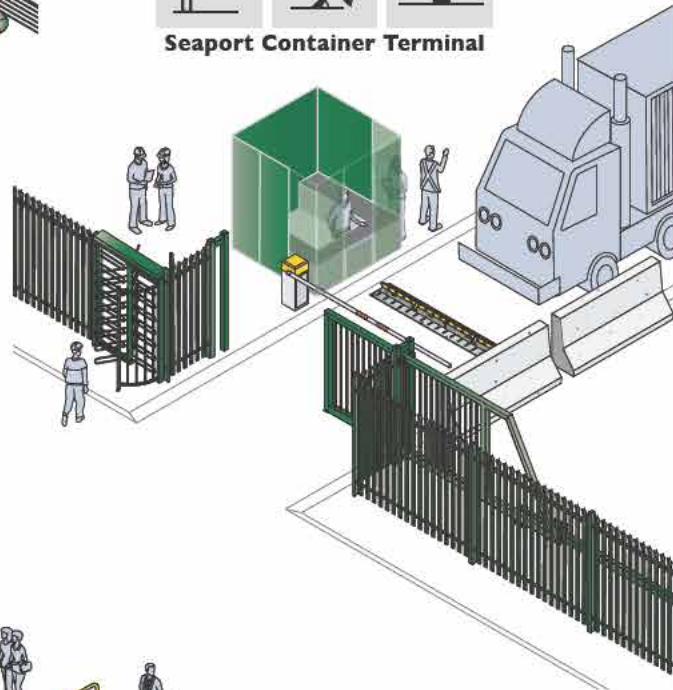

Sports Stadium Exit

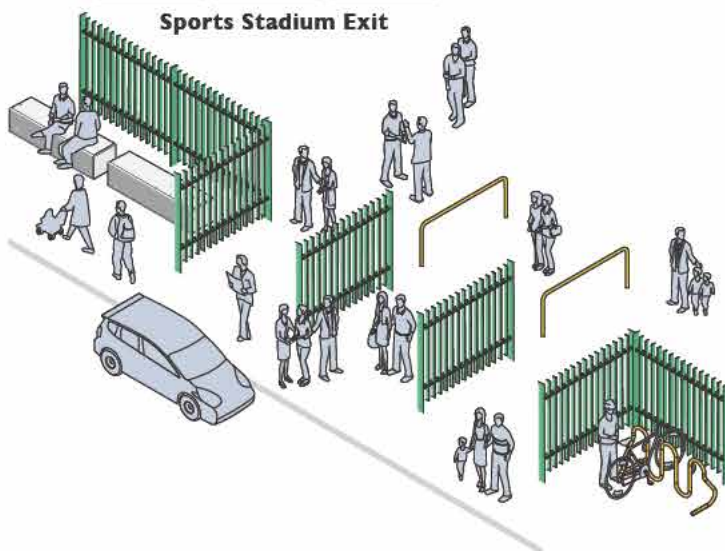

Intro	2
Gates	14
Track	20
Cantilever	30
Swing	40
Bi-fold	46
Boom	52
Options	76
General	82
<b>Barriers</b>	<b>94</b>
Blockers	100
Tyre Spikes	102
Pre-cast	106
Other	111
<b>Pedestrian</b>	<b>114</b>
Turnstiles	114
Gates & Doors	136
<b>Fencing</b>	<b>142</b>
<b>Code Index</b>	<b>153</b>

☎ 1300 780 450



Leda has been actively involved in designing and testing its physical security products for more than 10 years. Testing programs have been conducted both in Australia and in the United Kingdom providing invaluable data for Leda's engineers and project managers.

During this time, Leda has developed the largest range of engineered and vehicle impact tested high security products available in Australia.

With these products Leda is able to offer two levels of certified security ratings for high security equipment where vehicle weight and speed are part of the equipment specification.

### Impact Tested and Certified

There are two widely recognised standards:

**BSI. PAS68 & PAS69** – from the UK.

PAS68 2010 evolved to address the needs of governments, security consultants and organisations in the UK who wished to have the assurance that vehicle security barriers will provide the level of security sought.

Published by BSI (UK) the standard was developed to set out the test criteria for hostile vehicle mitigation products and caters for the wide range of products and systems that are considered for use as vehicle security barriers.



It is a rating system designed to accommodate many different products by recording through testing:

- Vehicle size and weight
- Vehicle speed
- Penetration
- Debris dispersal
- Performance of the installation and post impact condition

PAS69: 2006 provides guidance for installing the barriers.

**ASTM** – from the USA (formally K4-12 DOS standard).

Trucks designed and manufactured in the US and tested under the ASTM standard are not readily available in Australia and the behaviour of the vehicle during impact testing is significantly different to vehicles manufactured in Europe and ASIA.

So while there is no problem with USA vehicles the predominant test standard used in Australia is the PAS68 from the UK. Both standards are still evolving and we believe in time may converge, but for now the PAS68 standard is preferred by Australian security consultants and government departments.



1300 780 450

### Engineered Solutions

There are potentially two options:

- Alterations to a PAS68 product due to site or requirements, or
- Designing site specific products (to meet vehicle impact weight, speed and specifications).

Products are engineered and not impact tested.

In a perfect world, we should impact test every product and then install it identically on site. More often than not however, site considerations dictate changes that can be due to variations such as soil conditions, road camber, underground services, width or height changes, aesthetic requirements or cost considerations.

The PAS68 standard itself allows for engineered solutions under certain circumstances and in these instances, Leda uses UK-based Civil Engineering firms actively engaged in the CPNI Hostile Vehicle Mitigation (HVM) program and who have specific experience in designing foundation footings and the installation of PAS68 products. This knowledge and experience is critical and needs to be emphasised.

### Cost Considerations

**“We like PAS68 equipment but are not sure if our Budget is sufficient to cover the cost.”**

Leda appreciates and understands the problem. Leda staff have extensive experience in meeting budget restraints. They are a fact of life, even on Government projects.

While most clients considering impact rated equipment would love to magically click their fingers and use PAS68 tested equipment, there are cost considerations that cannot be ignored. Each impact test costs \$50,000 - \$100,000 and these costs need to be recouped in the product price. This makes the tested product more expensive than non-tested engineered solutions. It does however provide the certainty that the product (if installed correctly) will meet certain impact specifications.

With each year, engineering innovations such as shallow mount foundations and stronger and lighter weight materials, are being developed that are greatly reducing costs for high security hostile vehicle products.

Quite often if it’s a new site or threat, then a security budget / capital expenditure may not have been initially planned for. Engineered solutions are quite common and unlike PAS68 tested equipment, poorly installed products and installations are commonly found. This area of security is often a ‘grey area’ that can attract unscrupulous operators taking advantage of loose specifications and using inexperienced engineers that, while well-intentioned, may not have the required expertise in this specification area.



### Selecting a Security Equipment Supplier

Leda recommends the following be considered in your decision making process for engineered solutions.

The equipment supplier must be able to demonstrate greater than two years’ experience in PAS68 products and their installation. They should provide references of successfully completed projects of both tested and engineered sites in your city:

- The engineering firms engaged by the equipment supplier to design the footings must have greater than two years’ experience in PAS68 and engineered solutions so as to demonstrate an understanding of dynamic loads required in this field.
- If using security consultants then CPNI training in the UK or Australia for vehicle borne threats is highly recommended.
- Impact rating – vehicle weight and speed, must be clearly defined by you the client.
- If you are cautious and diligent in considering various product proposals then engineered solutions done properly can be a common and cost-effective option.



### Summary

As we have explained, PAS68 products and engineered solutions are more expensive than possible similar “off the shelf” equipment. There is simply no point in specifying and installing PAS68 or engineered equipment unless you can be sure that the costs are justified, otherwise money can be saved by installing a standard (gate or boom gate) product.

<b>Intro</b>	<b>2</b>
<b>Gates</b>	<b>14</b>
Track	20
Cantilever	30
Swing	40
Bi-fold	46
Boom	52
Options	76
General	82
<b>Barriers</b>	<b>94</b>
Blockers	100
Tyre Spikes	102
Pre-cast	106
Other	111
<b>Pedestrian</b>	<b>114</b>
Turnstiles	114
Gates & Doors	136
<b>Fencing</b>	<b>142</b>
<b>Code Index</b>	<b>153</b>













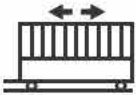

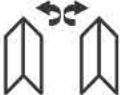
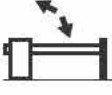

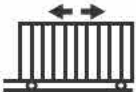
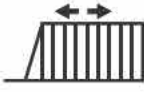
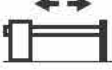

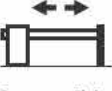

## Intro > Security classes

☎ 1300 780 450

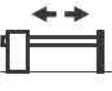
The table below is intended as a general guide to the relative strength (impact rating) of the various products in the Leda gates and barriers range. Products have been grouped in three Security Classes.

For further technical information or specific product certification, please contact Leda Security on 1300 780 450.

- 3 High security**  
Anti-terrorist
- 2 Medium security**  
Heavy commercial / industrial
- 1 Low security**  
Light commercial / industrial

	Track Gates	Cantilever Gates	Swing Gates	Bi-fold Gates	Boom Gates
High Security	 Crash Gate		 V Gate	 High Security	 Newey – Vertical
			 Cityscape Gate		 Defender – Vertical
	 High Security	 High Security			 High Security – Sliding
Medium Security	 Security	 Security	 Security	 Security	 Security – Sliding
					 Security – Vertical
Low Security	 Industrial	 Industrial	 Industrial		 Industrial – Sliding
					 Industrial – Vertical
	 Advantage	 Advantage	 Advantage		 Industrial – Swinging

The above table is intended to act as a general guide to the relative strength of the various products in the Leda Security Products range. Leda Security makes no claims as to the validity of independent testing and product positioning in the guide. For specific impact resistance related to any product or site, Leda Security should be contacted to evaluate engineering requirements. Leda Security's research and development policy is one of constant improvement, continuously working towards further validating and testing their products for accurate impact ratings. The above ratings are therefore subject to change as engineering adjustments and advances are being constantly made.

☎ 1300 780 450



Intro	2
Gates	14
Track	20
Cantilever	30
Swing	40
Bi-fold	46
Boom	52
Options	76
General	82
<b>Barriers</b>	<b>94</b>
Blockers	100
Tyre Spikes	102
Pre-cast	106
Other	111
<b>Pedestrian</b>	<b>114</b>
Turnstiles	114
Gates & Doors	136
<b>Fencing</b>	<b>142</b>
<b>Code Index</b>	<b>153</b>

Road Blockers

Tyre Spikes

Barriers

Turnstiles

Fencing



Heavy Duty – Cast-in



Heavy Duty – Shallow Mount



Heavy Duty – Cast-in



Heavy Duty – Surface Mount



Light Duty – Surface Mount



Light Duty – Cast-in



Light Duty – Surface Mount

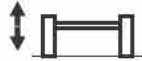

VBB Barrier

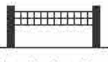

Barrier in a Box



Concrete Barriers



Logs



Planters



Steel Barriers



Full Height High Security



Full Height Security



Full Height



Full Height Polycarbonate



Half Height



Bristorm

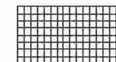

Security



Palisade

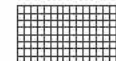

Securamesh



Redfern



Bastille



Premier

High Security

Medium Security

Low Security

# Gates General > The Leda gate range at a glance

☎ 1300 780 450

## Australia's preferred gate manufacturer

Leda's gate range has long been considered the industry standard. Gate applications cover a wide spectrum ranging from once-a-day operation for factories and industrial sites through to the demands of the constant operation required for access control in high security operations. Whether for light duty or high security and anti-terrorist protection, Leda has the product.

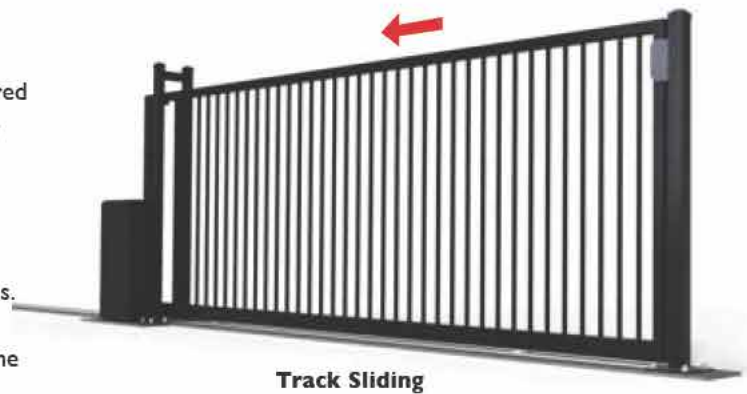

Single gates displayed are shown left hand opening, viewed from the secure side. Right hand opening gates are also available.

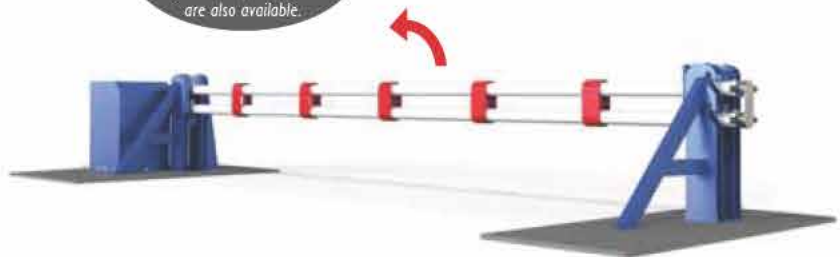

### High Security Vertical Boom

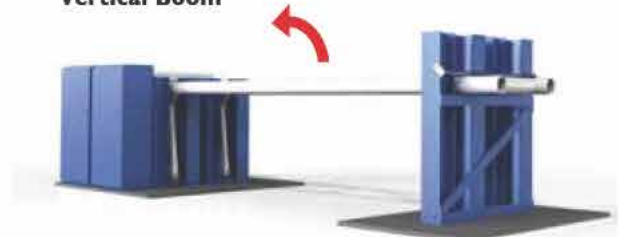

### Manual & Automatic Vertical Boom

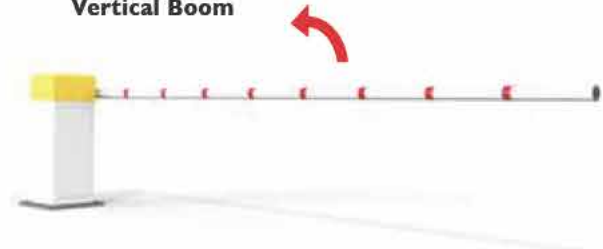

## Features

- Designed, manufactured & installed by Leda
- Strong, durable, corrosion-protected steel
- Control cabinets to AS standards, variable speed drive motors
- Engineer-designed footings for real security
- Occupational Health & Safety compliance
- Backed by Leda's unparalleled technical and design experience.

## Applications

- Industrial areas
- Airports and shipping ports
- Military complexes
- Power stations
- Private car parks
- Distribution depots
- Government utilities
- Mining sites



# Gates General > The Leda gate range at a glance

☎ 1300 780 450

Full specification details for Leda gates can be downloaded as a PDF document: [www.ledasecurity.com.au/gates](http://www.ledasecurity.com.au/gates) > (gate type) > specification

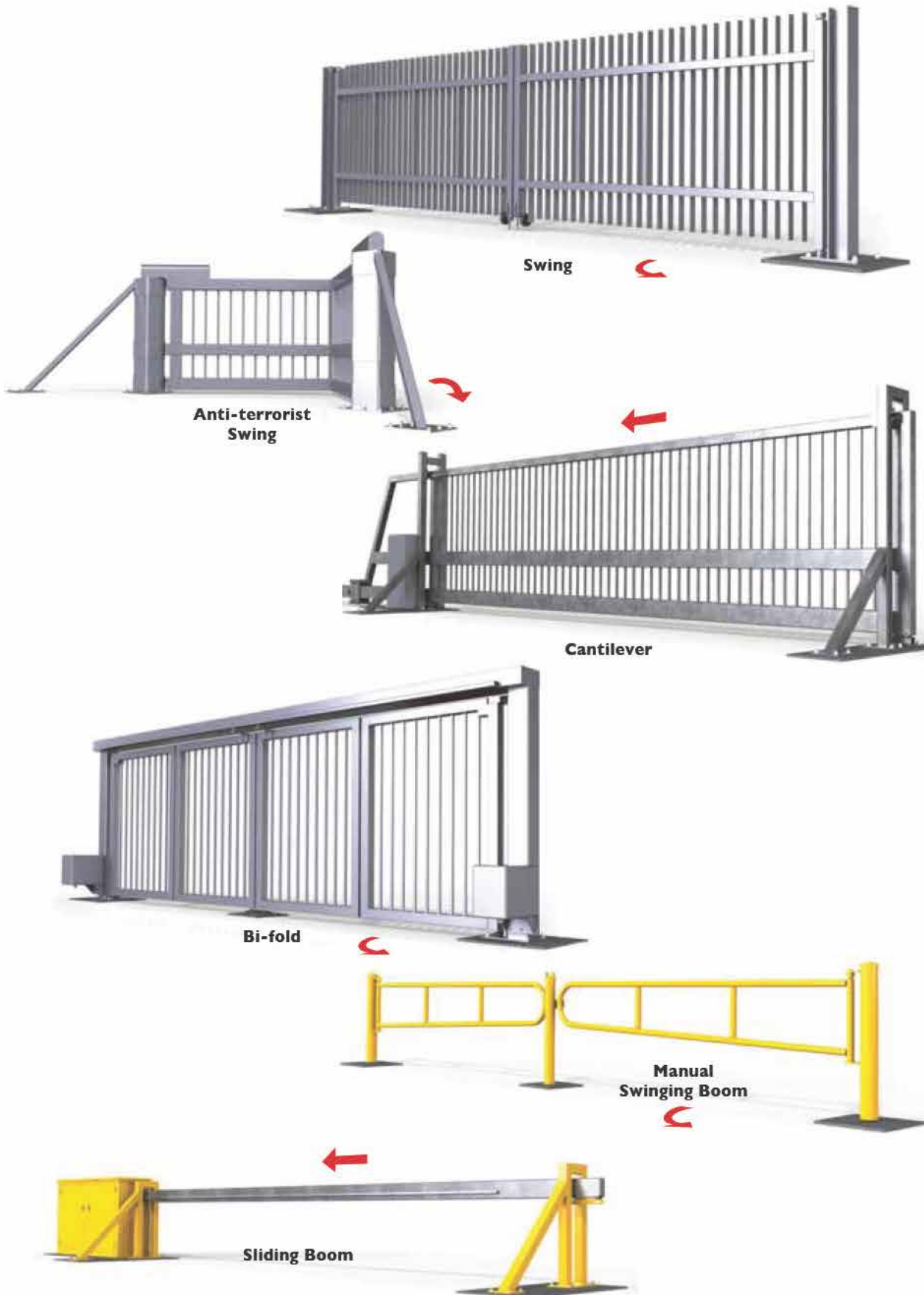

<b>Intro</b>	<b>2</b>
<b>Gates</b>	<b>14</b>
Track	20
Cantilever	30
Swing	40
Bi-fold	46
Boom	52
Options	76
General	82
<b>Barriers</b>	<b>94</b>
Blockers	100
Tyre Spikes	102
Pre-cast	106
Other	111
<b>Pedestrian</b>	<b>114</b>
Turnstiles	114
Gates & Doors	136
<b>Fencing</b>	<b>142</b>
<b>Code Index</b>	<b>153</b>

## Gates General > Features of Leda gate technology

☎ 1300 780 450

Not all gates available in Australia are created equal and it is essential that you arm yourself with relevant information to compare gate quotations. Leda considers its product to be 'best practice' and this section illustrates some important features that you should look for in a gate.

Checklist	Leda	Other
Master Security License holder	<input checked="" type="checkbox"/>	<input type="checkbox"/>
Structurally designed footings	<input checked="" type="checkbox"/>	<input type="checkbox"/>
Australian Standards compliance		
Footings	<input checked="" type="checkbox"/>	<input type="checkbox"/>
Materials	<input checked="" type="checkbox"/>	<input type="checkbox"/>
Electrical	<input checked="" type="checkbox"/>	<input type="checkbox"/>
Safety options available	<input checked="" type="checkbox"/>	<input type="checkbox"/>
Service program in place	<input checked="" type="checkbox"/>	<input type="checkbox"/>
Automation to meet duty cycle	<input checked="" type="checkbox"/>	<input type="checkbox"/>
Public and product liability coverage	<input checked="" type="checkbox"/>	<input type="checkbox"/>
Shop drawings supplied	<input checked="" type="checkbox"/>	<input type="checkbox"/>
Current site work method statements	<input checked="" type="checkbox"/>	<input type="checkbox"/>
One year warranty [Refer T&C]	<input checked="" type="checkbox"/>	<input type="checkbox"/>
Australia-wide – 20 years' experience	<input checked="" type="checkbox"/>	<input type="checkbox"/>
National Code Compliance	<input checked="" type="checkbox"/>	<input type="checkbox"/>
Project Management	<input checked="" type="checkbox"/>	<input type="checkbox"/>

### Beware of inferior products!

Poor quality industrial gates fabricated with light duty materials, fitted with cheap, underpowered drive motors are being supplied in the market. Too often gate selection is based on price – resulting in an expensive retrofit 12-24 months later.

Leda is often called out to repair, replace or service inappropriate product recommended by inexperienced suppliers. Take the time to carefully evaluate what to look for in selecting a gate.

### Advice on the right options

Experienced sales staff will inspect your site to acquaint themselves with what's needed and provide you with recommended proposals. They will also discuss with you the numerous options available:

- Gate infills / top extensions
- OH&S requirements and options
- Drive systems (motors and gear boxes)
- Power (mains or solar)

Many options will be driven by the level of security and the estimated daily operational requirements.

> For more information on the range of options, refer *Options & Accessories* on p76.

## Manufacturing

### Materials

Leda uses high quality Australian steel to AS standards. Leda recommends that strong, durable steel be used for all perimeter security in commercial applications.

### Corrosion protection & finishing

Leda offers a selection of protective finishes from hot dipped galvanising to powder coating in a range of colours.

### Gate stops

Standard on all Leda gates. Important for synchronisation, safety and trouble-free operation.



## Operation

### Electric cabinet

Our cabinets are C-ticked certified and meet all relevant AS safety standards for electrical cabinets.

### Automation

Leda will match your gate motor to power requirements – a combination of gate size and/or weight and operations per peak hour required.

### Operating speeds

Recommended speed is standard at 400mm/sec opening and closing. Faster (up to 800mm/sec) or slower speeds are available.

Dampers are recommended for sliding gates installed on sloping ground, to restrict gate speed during manual operation.

> Refer to *Options & Accessories*, p79.

☎ 1300 780 450

**Safety**

**OH&S procedures**

Some gates weigh more than 500kg, so Leda takes its staff and clients' safety extremely seriously. Independent safety audit reports are available on request.

> Refer to p78 for the complete range of Safety Options & Accessories.

**Runner enclosure**

An OH&S option Leda highly recommends is an enclosure around the recess where the gate retracts. Inexpensive chain wire fence will minimise the risk of accidental injury.

**Safety guard**

On each gate a mesh guard is permanently attached to the gate to ensure any person, including Leda service staff, does not have a limb through a gate at the wrong time.

**Options**

**Flashing lights**

**Audible signals**

**Traffic lights**

**Intrinsically safe options**

Available for hazardous and hostile environments like the chemical and petroleum industries.

**Infills – Top Sections / Fencing  
Column Beams**

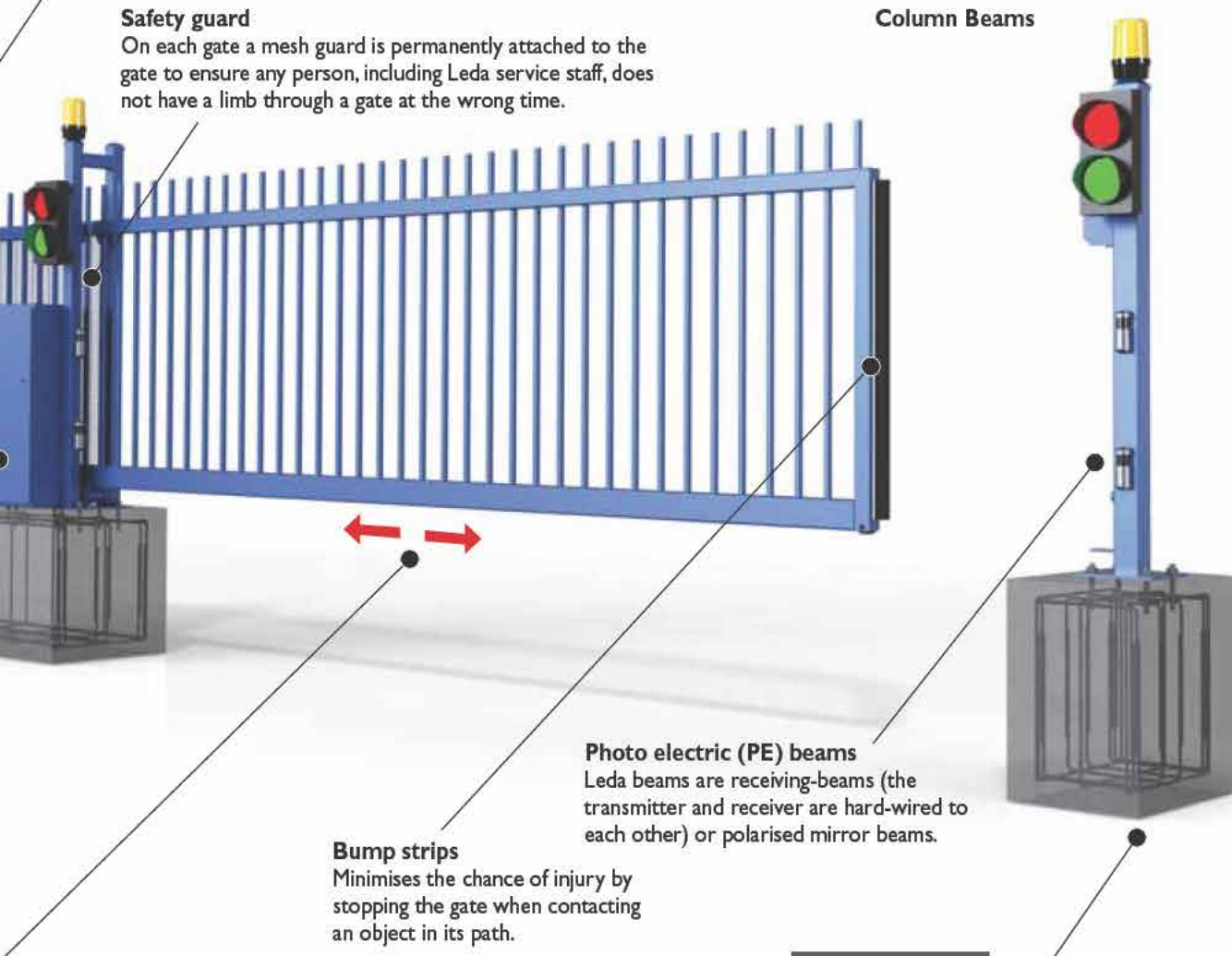

**Bump strips**

Minimises the chance of injury by stopping the gate when contacting an object in its path.

**Photo electric (PE) beams**

Leda beams are receiving-beams (the transmitter and receiver are hard-wired to each other) or polarised mirror beams.

**Shop drawings & design**

The majority of projects require signed shop drawings prior to the commencement of manufacturing. Drawings are completed in 3D and recorded for future spare parts.

**Installation**

**Structural footings**

Leda footings are designed by in-house civil engineers to ensure they meet the required structural and Australian standards for wind loadings. Leda engineers have recently designed a unique shallow mount footing that significantly reduces installation time and costs.

Intro	2
Gates	14
Track	20
Cantilever	30
Swing	40
Bi-fold	46
Boom	52
Options	76
General	82
<b>Barriers</b>	<b>94</b>
Blockers	100
Tyre Spikes	102
Pre-cast	106
Other	111
<b>Pedestrian</b>	<b>114</b>
Turnstiles	114
Gates & Doors	136
<b>Fencing</b>	<b>142</b>
<b>Code Index</b>	<b>153</b>



# Gates General > A Leda gate for every application

☎ 1300 780 450



Manufactured from strong RHS steel sections, the gates are supplied with heavy duty drive motors and gear boxes that are designed to last the life of the gate. Throughout the range, Leda has developed different 'duty levels' of many of the gate types using larger and heavier materials for more demanding usage applications.

Leda staff will assist in selecting the appropriate gate type for the proposed application to ensure both an optimum performance of the gate and a cost-effective solution.

Above, multi-leaf track gate spanning 34.5 metres, Pluto LNG Project, Burrup Peninsula WA, and right, customised swing gates, Redfern Park Sydney.



Gate Duty Level	Galvanised RHS Frame	Galvanised RHS Bottom Rail
Premier	<input type="checkbox"/>	<input type="checkbox"/>
Advantage	<input type="checkbox"/>	<input type="checkbox"/>
Industrial	<input type="checkbox"/>	<input type="checkbox"/>
Security	<input type="checkbox"/>	<input type="checkbox"/>
High Security	<input type="checkbox"/>	<input type="checkbox"/>

**\* Anti-terrorist Installations**  
 Leda manufactures gates and a range of other products for anti-terrorist installations. For security reasons these products are displayed but not detailed in the publication. For further information on PAS68 and SCEC certified products please contact your closest Leda sales office where your enquiry will be dealt with by an appropriately qualified consultant.

## Standard Drive System Features

- A range of various drive motors / gearboxes is available to suit the weight of the gate and the application. Variable Speed Drive (VSD) limit and/or proximity switches are used for position sensing.
- Features a manual override system in the event of a power failure.
- Controlled via a purpose-built control board, or optionally by a PLC.
- Flexible control boards and PLC units are used, allowing linkages to a range of peripheral applications like safety inputs, alarms, strobe lights, depending on client requirements.
- Standard system may be interfaced with most types of access control systems.
- High speed retracting ability – achieving up to 1 metre per second gate speed.
- Mains or eco solar power option. Many of Leda's gates are suitable for solar powered operation.

> Refer to the recommendations in the motor matrix tables under Options & Accessories.





# Gates General > A Leda gate for every application



☎ 1300 780 450

As most gates typically require some degree of customisation, Leda gates are not only available in a range of clear opening sizes and gate heights\*. They also offer a wide choice of gate infills and gate top extensions\*\*.

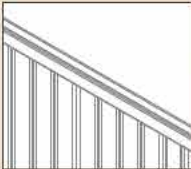
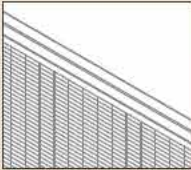
All Leda Track Sliding, Cantilever, Swing and Bi-fold gates offer a choice of gate infills and gate top extensions. Please refer to individual product specifications for availability.

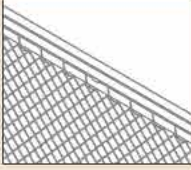
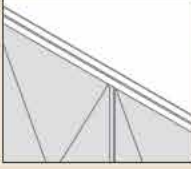
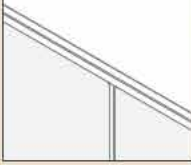
> Refer p76 for the full range of Options & Accessories.

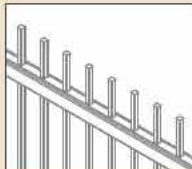
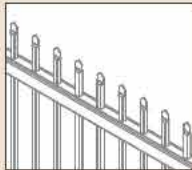
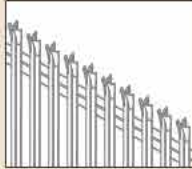
Gate Infills		
STANDARD		Square Pickets 25 x 25mm RHS
MESHGATE		Securamesh, anti-climb 71 x 9mm opening
PALGATE		Palisade Pickets (suit Palisade fencing)
CHAINGATE		Chain Link Mesh
ZINGGATE CBGATE		Zincalume Panel Colorbond® Panel
GLGATE		Glass Panel Security glass

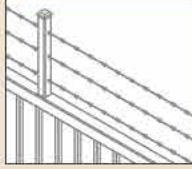
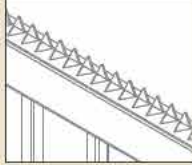
Gate Top Extensions		
TF		Flat Pickets 25 x 25mm RHS 200mm high
TC		Crimped Pickets 25 x 25mm RHS 200mm high
TP		Palisade Pickets 200mm high (suit Palisade infill)
TR		Razor Wire 450mm diameter, flat loop, short barbed. Incl 3 x barbed wire 500mm high
TB		Barbed Wire 3 strands 500mm high
TH		Shark Tooth Plate 25mm high

\* For most gates: Clear opening size range available in 1.0 metre increments; gate height range available in 0.3 metre increments.

\*\* Not available for Boom Gates.

## Product Code Generation

On each of the product specification pages you will find the necessary information to build a Product Code utilising the gate size range (clear opening and height) you require in your installation.

### Example:

You have chosen a heavy-duty track sliding gate for your application.

You require a clear opening of 7 metres and a height of 2.1 metres.

Gate Type	Track Sliding – Security	<b>TMS</b>
Clear Opening	7.0 metres	<b>TMS 70</b>
Gate Height	2.1 metres	<b>TMS70 21</b>

Intro	2
Gates	14
Track	20
Cantilever	30
Swing	40
Bi-fold	46
Boom	52
Options	76
General	82
Barriers	94
Blockers	100
Tyre Spikes	102
Pre-cast	106
Other	111
Pedestrian	114
Turnstiles	114
Gates & Doors	136
Fencing	142
Code Index	153



## Product Range > Gates > Track

☎ 1300 780 450

Track sliding gates are the most popular type of automated gates for industrial and commercial installations. Generally, they require less operating space than cantilever gates, and can be of lighter construction. They also have the added advantage of being able to accommodate very large clear openings particular when designed as a bi-parting or bi-slide operation.  
> Refer p29 for details.

There are five track gate types, each providing options to make gate selection an easy task. Steel sections (RHS) used during manufacture increase in size and wall thickness through the gate types to provide different levels of security.

Advantage	<input type="checkbox"/>
Industrial	<input type="checkbox"/>
Security	<input type="checkbox"/>
High Security	<input type="checkbox"/>
Anti-terrorist*	<input type="checkbox"/>

There is also a choice of drive motors / gear boxes catering for low and high operational requirements.  
> Refer p81 for details.

Tracks are normally surface mounted but can be mounted overhead depending upon the application.

**Advantage**  
Modular Panelled Gate



Gates displayed are shown left hand opening, viewed from the secure side. Right hand opening gates are also available.

**Industrial**

- Raked models available
- Bi-parting operation available
- Bi-slide operation available

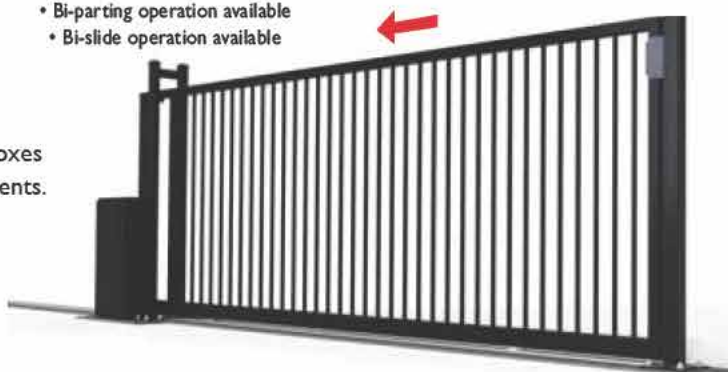
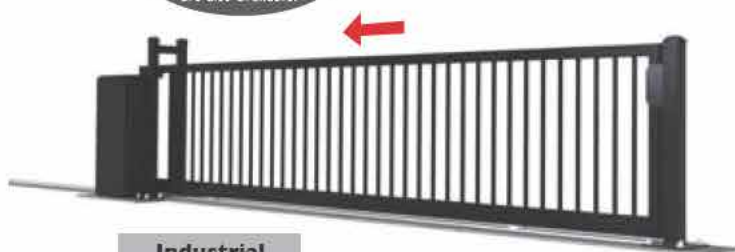

Duty Level	Code	Width Range	Height Range	Gate Infill *	Gate Top Extension *
Advantage <input type="checkbox"/>	<b>Modular</b> <b>AMTS</b>	2 panels 3.0-4.0m 3 panels 4.1-6.0m	2.1m only	RHS Pickets only	TH only
	<b>Standard</b> <b>ATS</b>	3.0m-6.0m 1.0m increments †	1.8m / 2.1m only	RHS Pickets only	TC / TF / TH
Industrial <input type="checkbox"/>	<b>Half Height</b> <b>ITSH</b>	3.0m-7.0m 1.0m increments †	1.0m / 1.2m only	Full Range	TC / TF
	<b>Full Height</b> <b>ITS</b>	3.0m-7.0m 1.0m increments †	1.8m-2.7m 0.3m increments †	Full Range	Full Range
	<b>'Redfern'</b> <b>RTS</b>	3.0m-6.0m 1.0m increments †	1.8m / 2.1m only	Flat Bars	Flat Bars
Security <input type="checkbox"/>	<b>TMS</b>	5.0m-15.0m ∞ 1.0m increments †	1.8m-3.0m 0.3m increments †	Full Range	Full Range
High Security <input type="checkbox"/>	<b>TMSH</b>	3.0m-8.0m 1.0m increments †	1.8m-3.6m 0.3m increments †	Full Range	Full Range
	<b>TMSH3</b>	3.0m-8.0m 1.0m increments †	2.5m only	Full Range	Full Range
	<b>ARSG45</b>	4.5m	0.85m only	n/a	n/a
Anti-terrorist *	<b>CGT</b>	3.0m-5.0m 0.5m increments †	2.1m / 2.4m only	Full Range	Full Range

\* Refer p19 for details. † Increments available within width and height range. ∞ Gate widths up to 20 metres are possible, contact your Leda sales office.



1300 780 450

Full specification details for Leda gates can be downloaded as a PDF document, [www.ledasecurity.com.au/gates](http://www.ledasecurity.com.au/gates) > (gate type) > specification

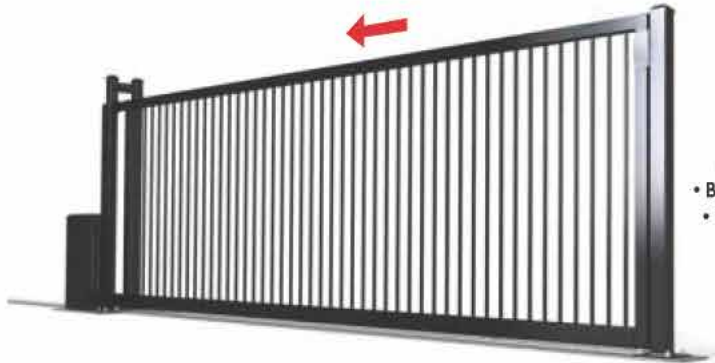

**Security**

- Raked models available
- Bi-parting operation available
- Bi-slide operation available



**High Security**

- Bi-parting operation available

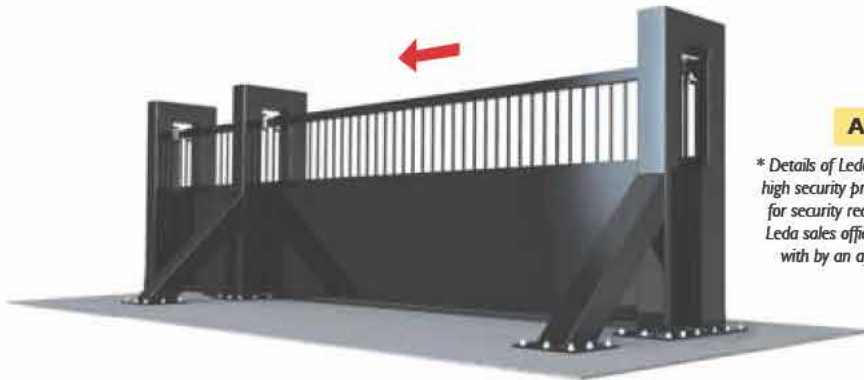

**Anti-terrorist\***

\* Details of Leda anti-terrorist gates and other Leda high security products are not detailed or specified for security reasons. Please contact your nearest Leda sales office where your enquiry will be dealt with by an appropriately qualified consultant.

Intro	2
Gates	14
Track	20
Cantilever	30
Swing	40
Bi-fold	46
Boom	52
Options	76
General	82
Barriers	94
Blockers	100
Tyre Spikes	102
Pre-cast	106
Other	111
Pedestrian	114
Turnstiles	114
Gates & Doors	136
Fencing	142
Code Index	153

Manual Operation Available	Bi-slide Option Available	Raking Available	Finish		
			Hot Dip Gal	Powdercoat	Wet Spray
Standard	No	No	Opt	Black only	N/a
Standard	No	No	Incl	Opt	Opt
Yes	No	Yes	Incl	Opt up to 6.0m only	Opt
Yes	Yes	Yes	Incl	Incl up to 6.0m only	Opt
Yes	No	Yes	Incl	N/a	
Yes (not recommended)	Yes	Yes	Incl	Opt up to 6.0m only	Opt
No	No	No	Incl	Opt up to 6.0m only	Opt
No	No	No	Incl	Opt up to 6.0m only	Opt
Yes	No	No	Incl	Opt	Opt
No	No	No	Incl	Opt	Opt

☎ 1300 780 450

**Advantage**

**Advantage Modular**



Viewed from secure side

**AMTS Fabrication**  
**Powdercoat RHS**  
 Frame 40 x 40 Bottom Rail 40 x 40

**ATS Fabrication**  
**Galvanised RHS**  
 Frame 50 x 50 Bottom Rail 100 x 50

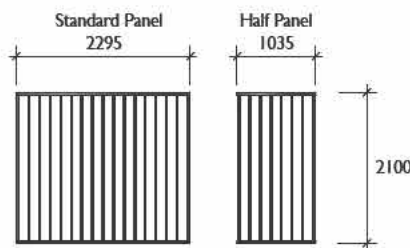
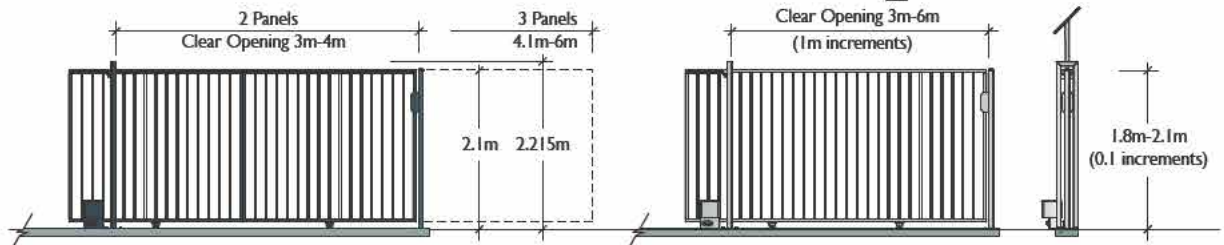

**DIY Installation**

- Advantage Modular**
- Available in kit form
  - Packed on a double pallet
  - Bolts together
  - Install and commission yourself

**Advantage Modular Gates**

Leda's Modular gates are robust, well designed and economical. They are easily transported, and easy to store and assemble.

The gates are supplied with everything that's needed to complete the installation. Even steel reinforcing for footings can be supplied pre-cut for assembly on site. A clear, simple instruction manual shows the steps required for trouble-free installation using a masonry drill and standard trade tools like spanners and screwdrivers.

**Benefits**

- Strong, robust mild steel construction.
- Australian designed and manufactured using high quality motors and running gear.
- Solar powered operation option.
- A range of access control systems including remote, keypad and mobile phone controls.
- Lower freight costs (fits on a double pallet).
- Reduced installation costs.
- Quick and easy to assemble.

**Applications**

- Industrial sites and factories
- Mining and rural sites
- Sporting fields and parks
- Power and water utilities

Track Advantage	Width Range	Height Range	Gate Infill	Top Extension
<b>AMTS Modular</b>	3.0m-6.0m	2.1m only	RHS Pickets only *	TH only *
<b>ATS</b>	3.0m-6.0m (1.0m †)	1.8m / 2.1m	RHS Pickets only *	TC / TF / TH *

† Increments available within width range. \* Refer p19 for details of Gate Infills and Top Extensions.

☎ 1300 780 450

**Industrial  
Half Height**

**Fabrication  
Galvanised RHS**

Frame  
75 x 75



Bottom Rail  
125 x 75

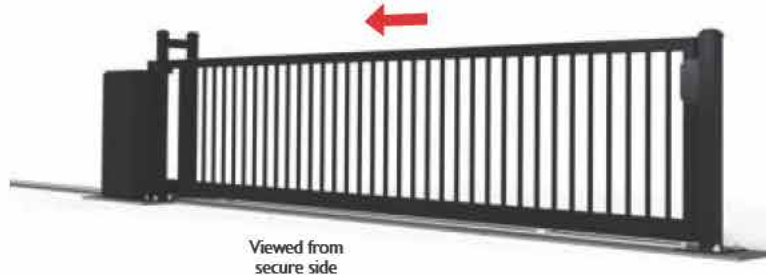

Viewed from secure side

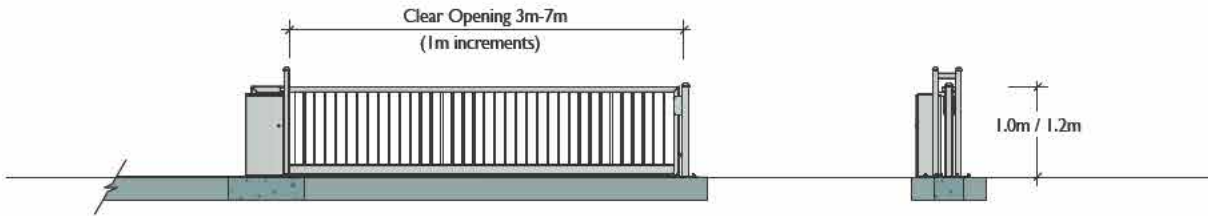

Track Industrial Half Height	Width Range	Height Range	Gate Infill	Top Extension
ITSH	3.0m-7.0m (1.0m †)	1.0m / 1.2m	Full Range *	TC / TF *

† Increments available within width range. • Refer p19 for details of Gate Infills and Top Extensions.

**Industrial  
Full Height**

**Fabrication  
Galvanised RHS**

Frame  
75 x 75



Bottom Rail  
125 x 75



**Most Popular Model**

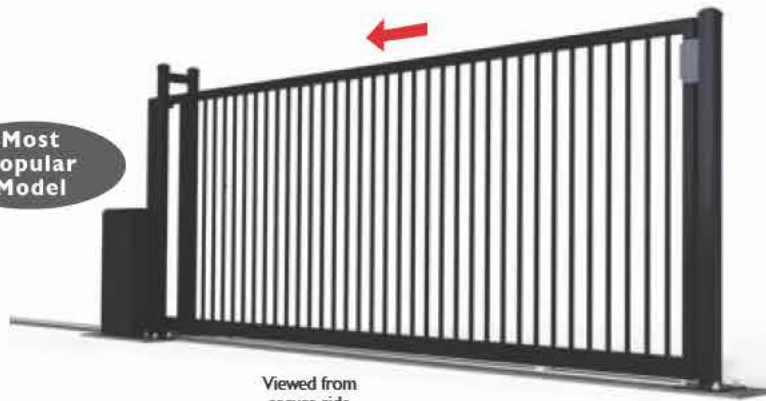

Viewed from secure side

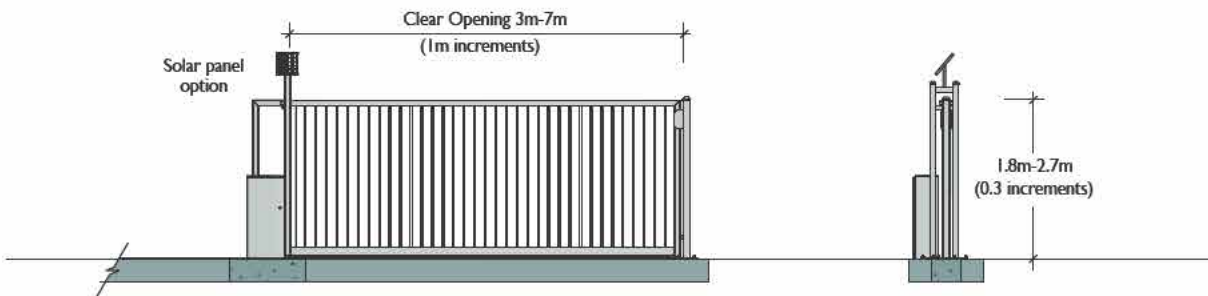

Track Industrial Full Height	Width Range	Height Range	Gate Infill	Top Extension
ITS	3.0m-7.0m (1.0m †)	1.8m-2.7m (0.3m †)	Full Range *	Full Range *

† Increments available within width and height range. • Refer p19 for details of Gate Infills and Top Extensions.

Intro	2
Gates	14
Track	20
Cantilever	30
Swing	40
Bi-fold	46
Boom	52
Options	76
General	82
Barriers	94
Blockers	100
Tyre Spikes	102
Pre-cast	106
Other	111
Pedestrian	114
Turnstiles	114
Gates & Doors	136
Fencing	142
Code Index	153



# Product Range > Gates > Track

☎ 1300 780 450

## Industrial Redfern

### Fabrication

- Rails  
75 x 75 RHS
- Pickets  
50 x 8 Flat Bar

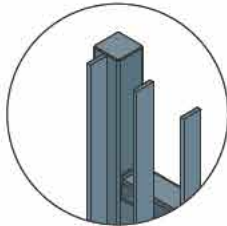

Redfern profile is also available as:  
Pedestrian Gate refer p138  
Fencing refer p144

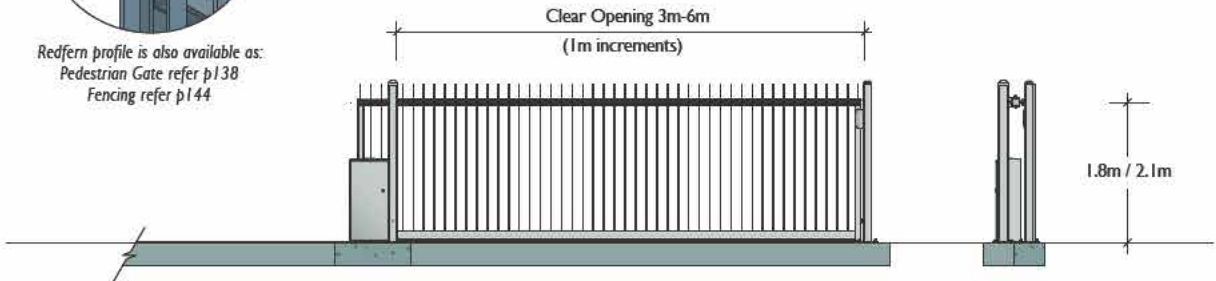
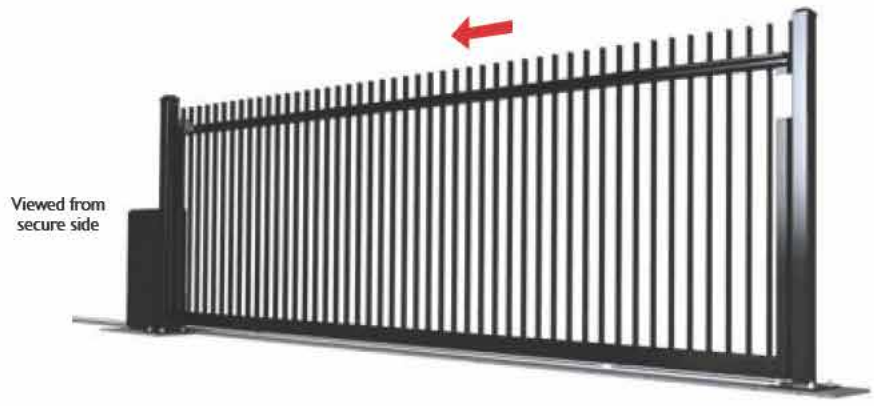

Track Industrial (Redfern)	Width Range	Height Range	Gate Infill	Top Extension
RTS Redfern	3.0m-6.0m (1.0m †)	1.8m / 2.1m only	Flat Bars	Flat Bars

† Increments available within width range.

## Raked Option

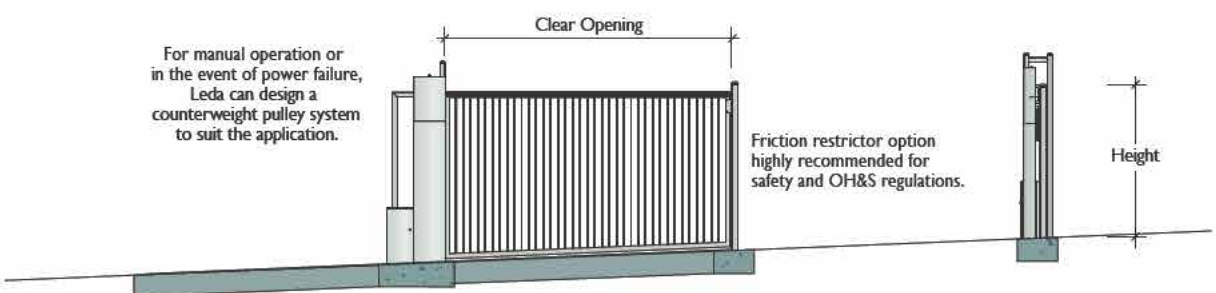
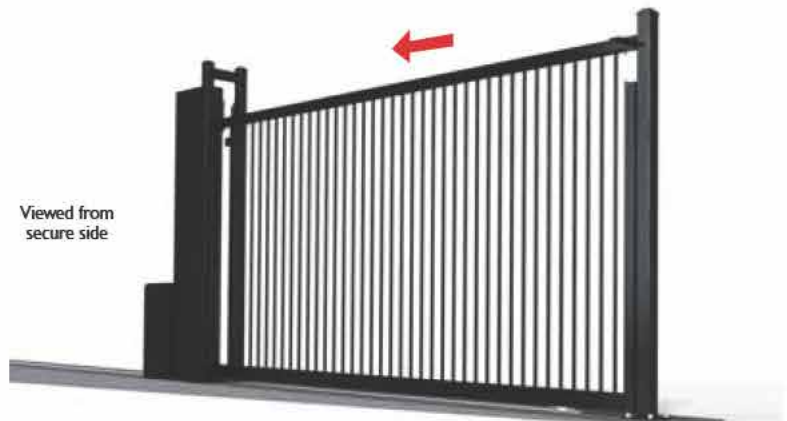

For manual operation or in the event of power failure, Leda can design a counterweight pulley system to suit the application.

Friction restrictor option highly recommended for safety and OH&S regulations.

To help overcome sloping driveway openings, track gates are available with a raked option. Raked track gates are available for Industrial (ITS) and Security (TMS) models.

1300 780 450

**Security**

**Fabrication Galvanised RHS**

Frame 100 x 100



Bottom Rail 150 x 100 / 200 x 100 (dependent upon span)

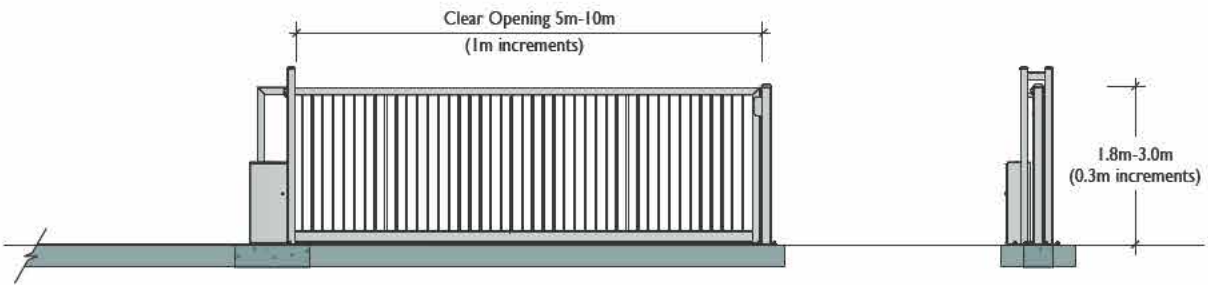
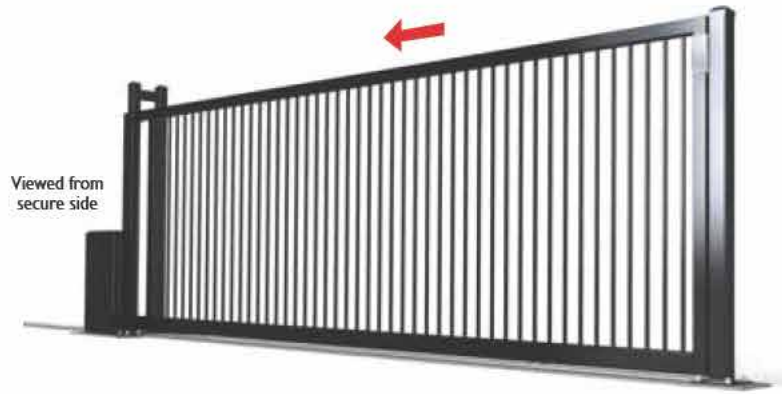

Track Security	Width Range	Height Range	Gate Infill	Top Extension
<b>TMS</b>	5.0m-15.0m (1.0m †)	1.8m-3.0m (0.3m †)	Full Range *	Full Range *

† Increments available within width and height range. \* Refer p19 for details of Gate Infills and Top Extensions.

**High Security**

**Fabrication Galvanised RHS**

Frame 100 x 100



Dual Bottom Rail 200 x 100

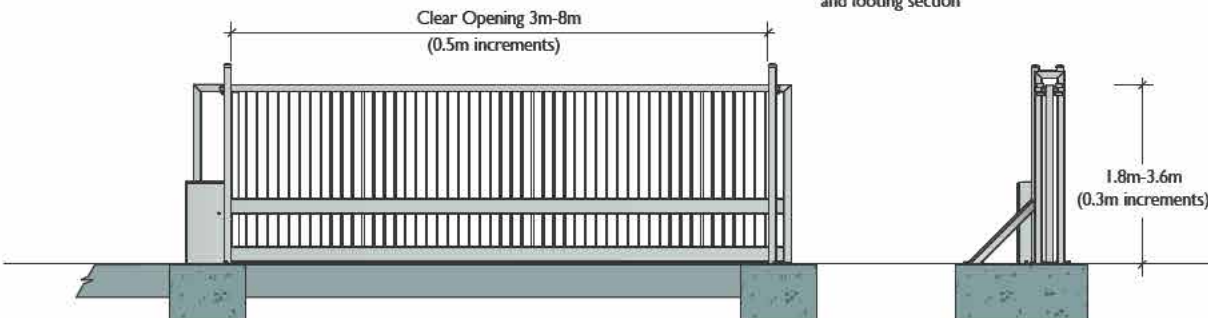
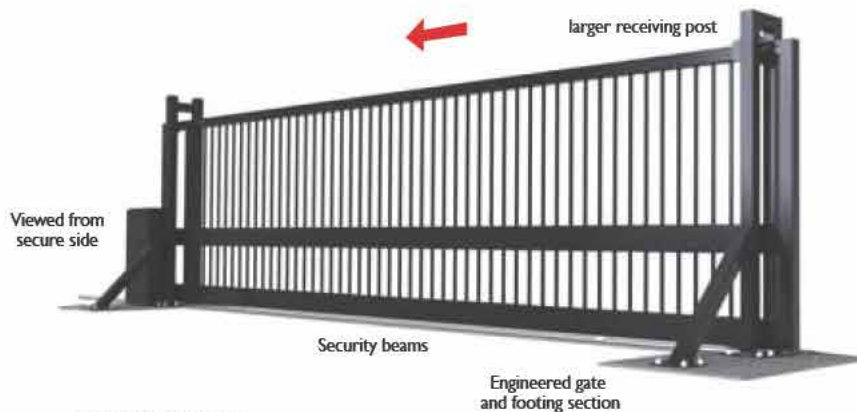

Track High Security	Width Range	Height Range	Gate Infill	Top Extension
<b>TMSH</b>	3.0m-8.0m (0.5m †)	1.8m-3.6m (0.3m †)	Full Range *	Full Range *

† Increments available within width and height range. \* Refer p19 for details of Gate Infills and Top Extensions.

Intro	2
Gates	14
Track	20
Cantilever	30
Swing	40
Bi-fold	46
Boom	52
Options	76
General	82
<b>Barriers</b>	<b>94</b>
Blockers	100
Tyre Spikes	102
Pre-cast	106
Other	111
<b>Pedestrian</b>	<b>114</b>
Turnstiles	114
Gates & Doors	136
<b>Fencing</b>	<b>142</b>
<b>Code Index</b>	<b>153</b>

1300 780 450

**High Security**

**ENGINEERED SOLUTION**

2.5 tonnes @ 40km/h

Viewed from secure side

Details of Leda anti-terrorist gates and other Leda high security products are not displayed or specified for security reasons.

Please contact your nearest Leda sales office where your enquiry will be dealt with by an appropriately qualified Leda staff member.

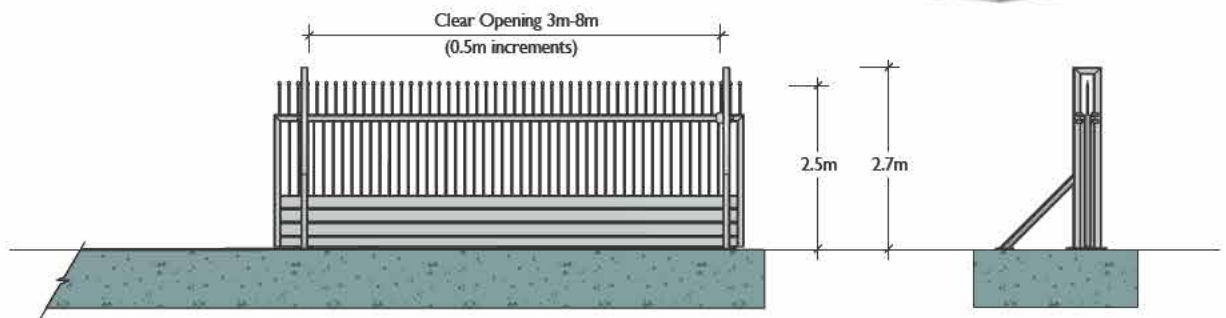

Track High Security	Width Range	Height Range	Gate Infill	Top Extension
<b>TMSH3</b>	3.0m-8.0m (0.5m †)	2.5m	Full Range *	Full Range *

† Increments available within width range. • Refer p19 for details of Gate Infills and Top Extensions.





1300 780 450

Anti Terrorist

Details of Leda anti-terrorist gates and other Leda high security products are not displayed or specified for security reasons. Please contact your nearest Leda sales office where your enquiry will be dealt with by an appropriately qualified Leda staff member.

**PAS68 TESTED**

**Tested and Certified**  
V7500 (N2) 48/90

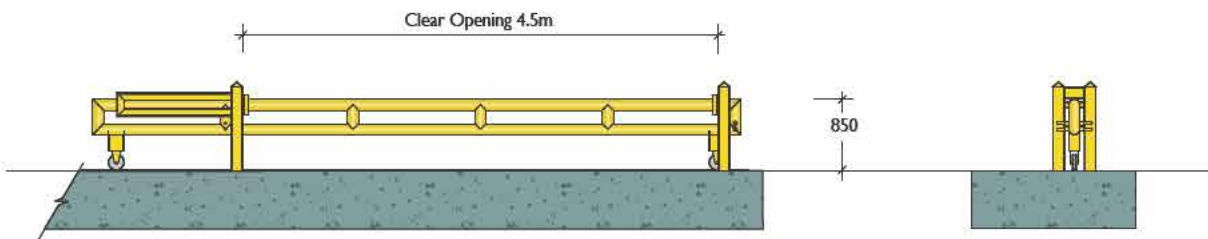
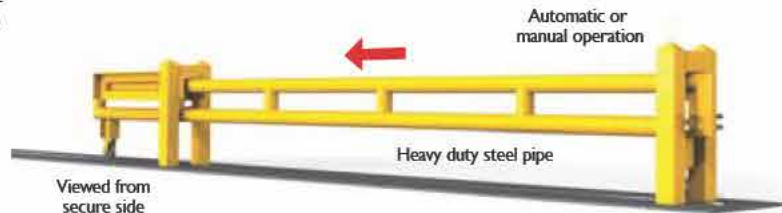

Track Anti-terrorist	Width Range	Height Range	Gate Infill	Top Extension
<b>ARSG45</b>	4.5m	0.85m	n/a	n/a

Anti Terrorist

**ENGINEERED SOLUTION**

7.5 tonnes @ 80km/h

Details of Leda anti-terrorist gates and other Leda high security products are not displayed or specified for security reasons. Please contact your nearest Leda sales office where your enquiry will be dealt with by an appropriately qualified Leda staff member.

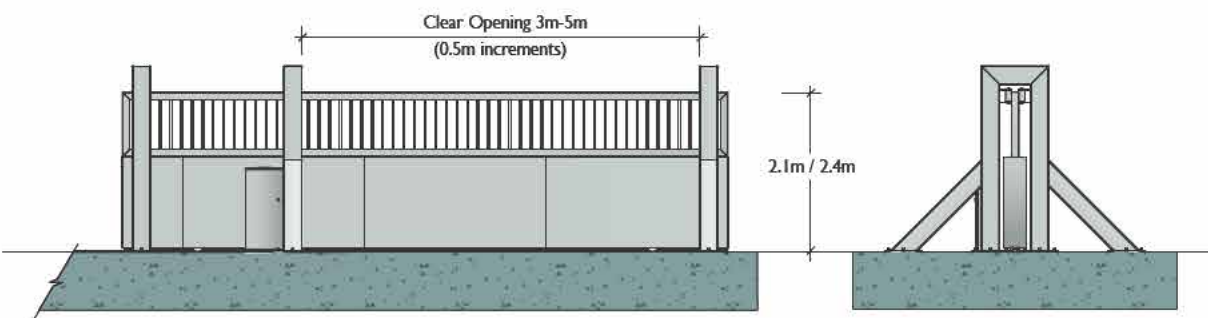

Track Anti-terrorist	Width Range	Height Range	Gate Infill	Top Extension
<b>CGT</b>	3.0m-5.0m (0.5m †)	2.1m / 2.4m	Full Range *	Full Range *

† Increments available within width range. • Refer p19 for details of Gate Infills and Top Extensions.

Intro	2
Gates	14
Track	20
Cantilever	30
Swing	40
Bi-fold	46
Boom	52
Options	76
General	82
<b>Barriers</b>	<b>94</b>
Blockers	100
Tyre Spikes	102
Pre-cast	106
Other	111
<b>Pedestrian</b>	<b>114</b>
Turnstiles	114
Gates & Doors	136
<b>Fencing</b>	<b>142</b>
<b>Code Index</b>	<b>153</b>

## Product Range > Gates > Track > Track Options

© 1300 780 450

The type of track suitable for your gate selection will depend on site conditions, whether a new or retro-fit installation and the overall size and weight of the gate.

Leda can provide a number of track types that are normally available in 3.0 metre and 6.0 metre lengths as well as standard AS41 rail line for larger gates.

Code  
SPDT55

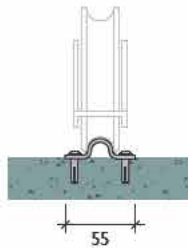

**Standard Pin-down Track**  
Most widely used.  
Galvanised finish.  
Installed with masonry anchors.  
Easy to retro-fit.  
Lighter duty gates up to 8m wide.

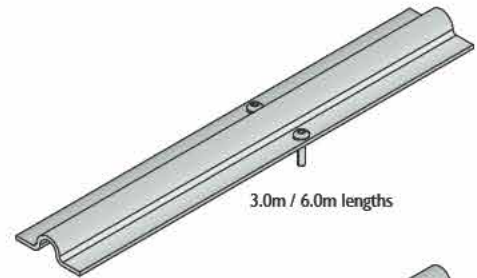

Code  
SCIT60

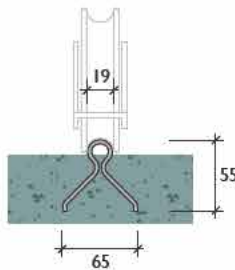

**Standard Cast-in Track**  
Galvanised finish.  
Suitable for casting-in to concrete.  
Lighter duty gates.

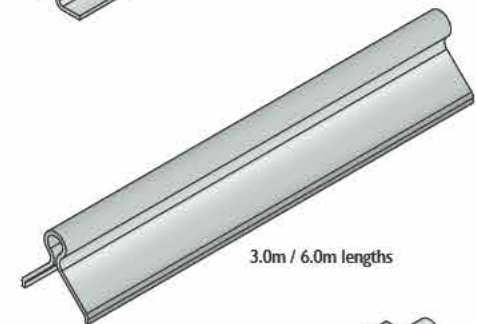

Code  
HBDT

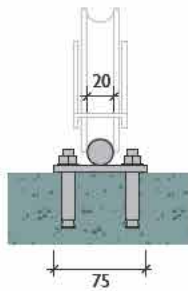

**Heavy Bolt-down Track**  
Galvanised finish.  
Installed with masonry anchors.  
Easy to retro-fit.  
Heavier duty gates.  
**Standard on all gates 8m and over.**  
**Optional on gates smaller than 8m.**

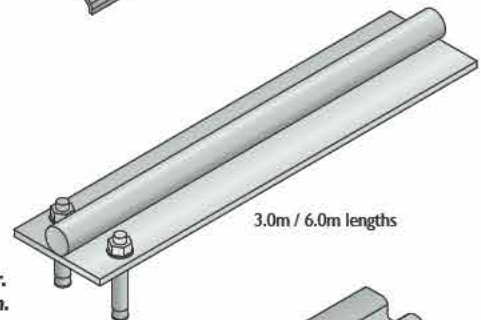

Code  
HCIT

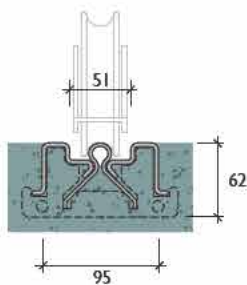

**Heavy Cast-in Track**  
Galvanised finish.  
Heavier duty gates.  
Suitable for areas with forklift traffic and frequent heavy vehicle truck traffic.

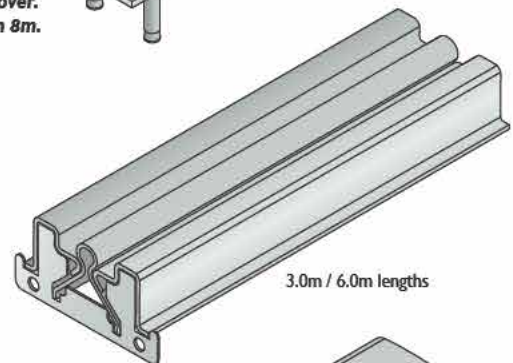

Code  
VHDRT

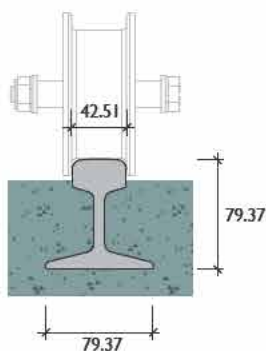

**Very Heavy Duty Rail Track**  
(AS15 standard rail)  
Suitable for casting-in to concrete.  
Heavier duty security gates.  
  
Weight: 15.2kg/m  
Tensile strength: 569N/mm<sup>2</sup> (min)

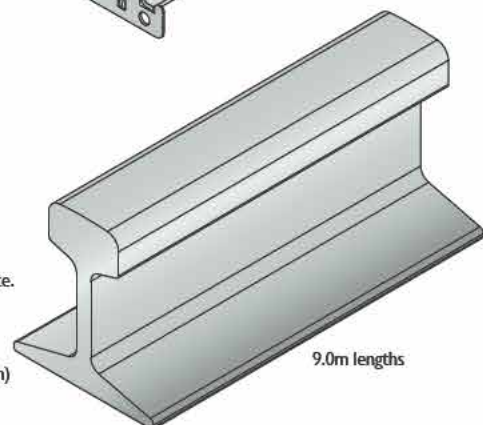

☎ 1300 780 450

**Bi-slide Options**

Bi-slide and bi-parting options are available for Industrial (ITS) and Security (TMS) gate models. These are ideal on sites where restricted space and/or very large openings (in excess of 20 metres) prevent the use of a single leaf gate.

Bi-slide gates utilise a wire cable pulley system that allows the second leaf to travel at quicker speeds, resulting in all leaves reaching the final open or closed position at the same time.

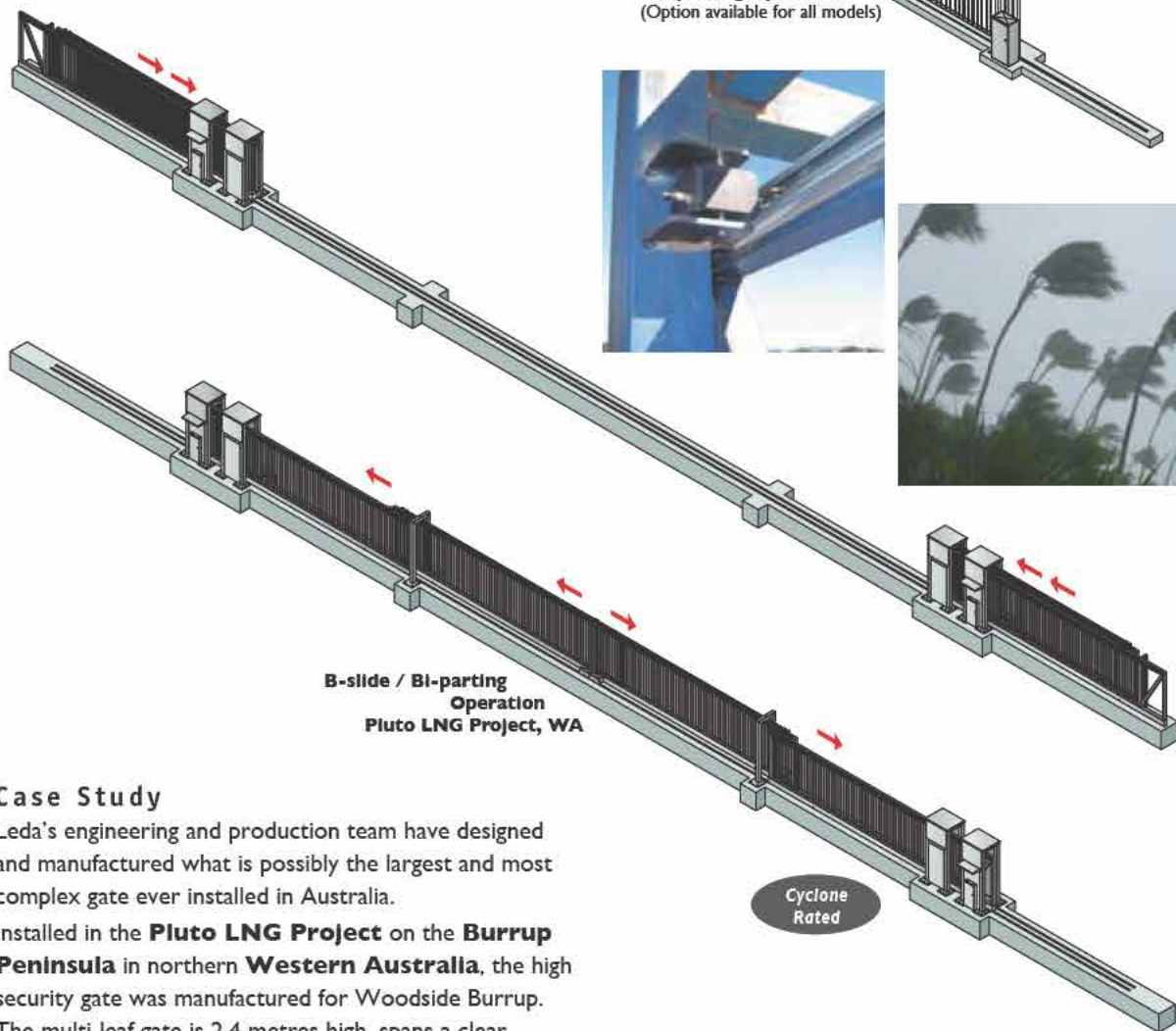
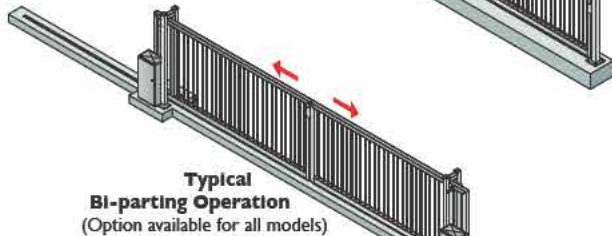
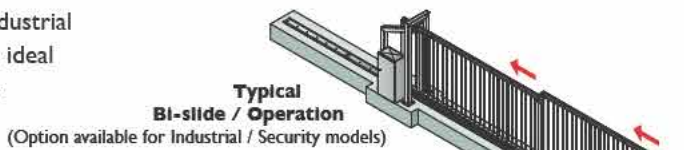

**Case Study**

Leda's engineering and production team have designed and manufactured what is possibly the largest and most complex gate ever installed in Australia.

Installed in the **Pluto LNG Project** on the **Burrup Peninsula** in northern **Western Australia**, the high security gate was manufactured for Woodside Burrup. The multi-leaf gate is 2.4 metres high, spans a clear opening of 34.5 metres and operates on AS41 railway track due to its immense size and weight.

Manufactured with four gate leaves, the complex design has carriage connections between the leaves mounted on large side bearings, allowing each leaf to follow track variations independently while maintaining the strength to meet cyclonic winds that the site could experience. Sophisticated microwave beams have been implemented for safety, with all electrics contained in stainless steel enclosures.



Intro	2
Gates	14
Track	20
Cantilever	30
Swing	40
Bi-fold	46
Boom	52
Options	76
General	82
<b>Barriers</b>	<b>94</b>
Blockers	100
Tyre Spikes	102
Pre-cast	106
Other	111
<b>Pedestrian</b>	<b>114</b>
Turnstiles	114
Gates & Doors	136
<b>Fencing</b>	<b>142</b>
<b>Code Index</b>	<b>153</b>



## Product Range > Gates > Cantilever

☎ 1300 780 450

The major feature of Leda's cantilever gates is that they are only supported at one end and are designed to operate without the need for a surface mounted track across the driveway – beneficial in high traffic or heavy vehicle areas. Cantilever gates require less space than swing gates and are easier to safeguard. They are also a more reliable option than track sliding gates as they require no track maintenance.

There are five cantilever gate types, each providing options to make gate selection an easy task. Steel sections (RHS) used during manufacture increase in size and wall thickness through the gate types to provide different levels of security.

Advantage	<input type="checkbox"/>
Industrial	<input type="checkbox"/>
Security	<input type="checkbox"/>
High Security	<input type="checkbox"/>
Anti-terrorist*	<input type="checkbox"/>

While Leda gates can be installed using conventional concrete footings poured on site, Leda engineers have developed superior and cost-reducing alternative systems that make the task of installing industrial gates, simpler, quicker and cheaper.

> Refer p91 for details.

There is also a choice of drive motors / gear boxes catering for both low and high operational requirements.

> Refer p81 for details.

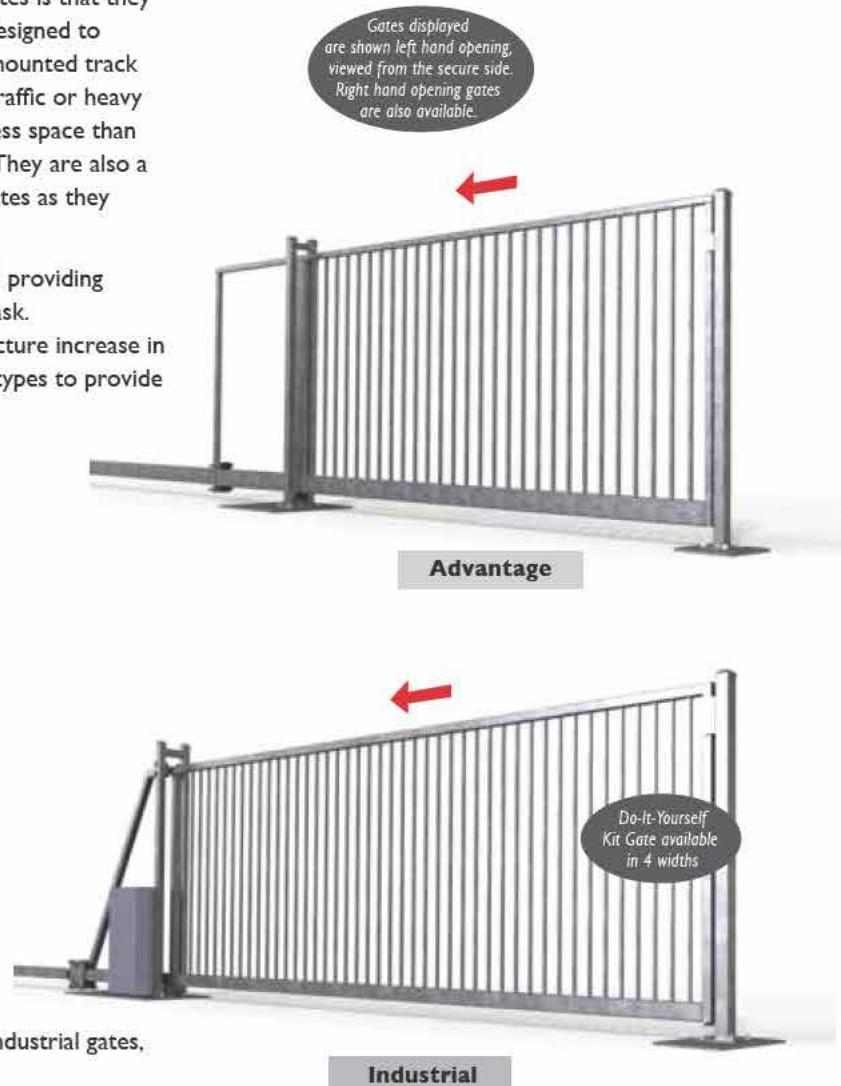

An alternative undercarriage system is available for Industrial and Security models. It is designed for sites with insufficient room to install a running rail, or where site conditions such as sand or snow drifts, effect operation.

Duty Level	Code	Width Range	Height Range	Gate Infill *	Top Extension *
<b>Advantage</b> <input type="checkbox"/>	<b>CLA</b>	3.0m-5.0m 0.1m increments †	1.8m / 2.1m only	RHS Pickets only	TH only
<b>Industrial</b> <input type="checkbox"/>	<b>ICL</b>	3.0m-6.0m 1.0m increments †	1.8m-2.7m 0.3m increments †	Full Range	Full Range
	<b>MLC</b> DIY Modular	5/6/7/8.5m only	2.5m only	Pickets	Shark Tooth
	<b>ICLU</b> Undercarriage	3.0m-6.0m 1.0m increments †	1.8m / 2.1m only	Full Range	Full Range
	<b>ICLUS</b> Undercarriage	3.0m-15.0m 1.0m increments †	1.8m / 2.7m only	Full Range	Full Range
	<b>Security</b> <input type="checkbox"/>	<b>CLS</b>	5.0m-10.0m 1.0m increments †	1.8m-3.0m 0.3m increments †	Full Range
<b>High Security</b> <input type="checkbox"/>	<b>CLSL</b>	12.0m-20.0m 1.0m increments †	1.8m-3.0m 0.3m increments †	Welded Mesh	Full Range
	<b>CLSH</b>	5.0m-8.0m 1.0m increments †	1.8m-3.6m 0.3m increments †	Full Range	Full Range
<b>Anti-terrorist*</b> <input type="checkbox"/>	<b>CGI2</b>	3.0m-9.0m	2.1m only	Full Range	Full Range

\* Refer p19 for details of Gate Infills and Top Extensions. † Increments available within width and height range.

1300 780 450

Full specification details for Leda gates can be downloaded as a PDF document: [www.ledasecurity.com.au/gates](http://www.ledasecurity.com.au/gates) > (gate type) > specification

**Security**

An alternative undercarriage system is available for Industrial and Security models. It is designed for sites with insufficient room to install a running rail, or where site conditions such as snow drifts, effect operation.



**High Security**



**Anti-terrorist\***

\* Details of Leda anti-terrorist gates and other Leda high security products are not detailed or specified for security reasons. Please contact your nearest Leda sales office where your enquiry will be dealt with by an appropriately qualified consultant.



<b>Intro</b>	<b>2</b>
<b>Gates</b>	<b>14</b>
Track	20
Cantilever	30
Swing	40
Bi-fold	46
Boom	52
Options	76
General	82
<b>Barriers</b>	<b>94</b>
Blockers	100
Tyre Spikes	102
Pre-cast	106
Other	111
<b>Pedestrian</b>	<b>114</b>
Turnstiles	114
Gates & Doors	136
<b>Fencing</b>	<b>142</b>
<b>Code Index</b>	<b>153</b>

Manual Operation Available	Raking Available	Finish		
		Hot Dip Gal	Powdercoat	Wet Spray
Standard	No	Incl	Opt	Opt
Yes	Yes	Incl	Opt up to 5.0m only	Opt
Yes	No	Incl	Opt	Opt
Yes	Yes	Incl	Opt up to 5.0m only	Opt
Yes	Yes	Incl	Opt up to 5.0m only	Opt
Yes (not recommended)	Yes	Incl	Opt up to 5.0m only	Opt
Yes (not recommended)	No	Incl	No	Opt
No	No	Incl	Opt up to 5.0m only	Opt
Yes	No	Incl	Opt up to 5.0m only	Opt

Product Range > Gates > Cantilever

☎ 1300 780 450

**Advantage**

**Fabrication**  
Galvanised RHS

Frame  
50 x 50  

Bottom Rail /  
Running Rail  
100 x 50  

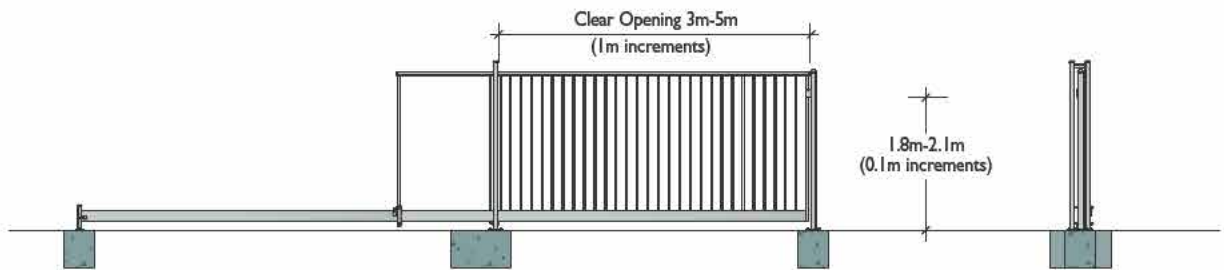
Cantilever Advantage	Width Range	Height Range	Gate Infill	Top Extension
CLA	3.0m-5.0m	2.1m only	RHS Pickets only *	Shark Tooth only *

\* Refer p19 for details of Gate Infills and Top Extensions.

**Industrial**

**Fabrication**  
Galvanised RHS

Frame  
75 x 75  

Bottom Rail/  
Running Rail  
125 x 75  

**Most Popular Model**

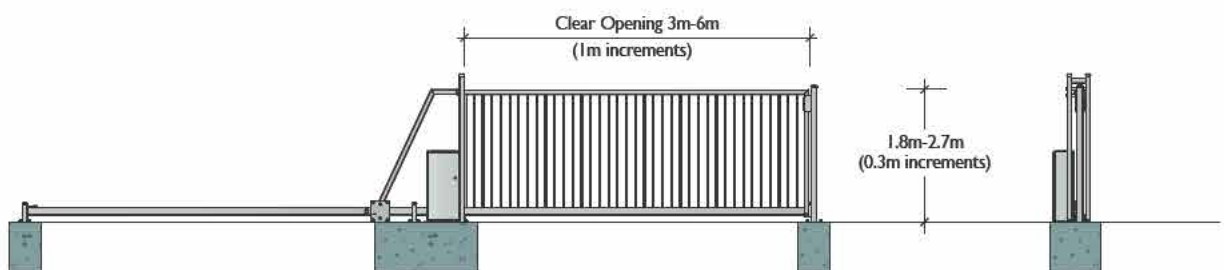
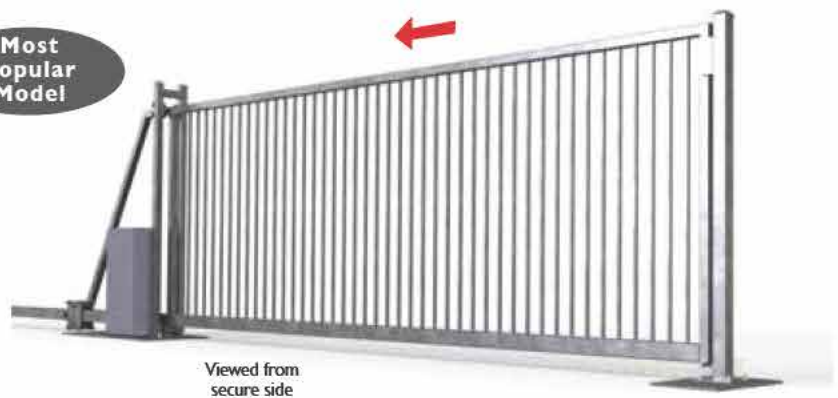

Cantilever Industrial	Width Range	Height Range	Gate Infill	Top Extension
ICL	3.0m-6.0m (1.0m †)	1.8m-2.7m (0.3m †)	Full Range *	Full Range *

† Increments available within width and height range. \* Refer p19 for details of Gate Infills and Top Extensions.



1300 780 450

**Industrial Undercarriage**

**Features**

- Centralised roller assembly
- Concealed rollers
- Eliminates the need for gate extensions

**Applications**

- Dusty, sandy locations, areas of snow drift
- Insufficient room to install a running rail
- Sloping sites

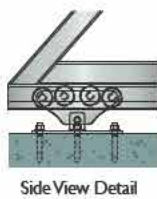
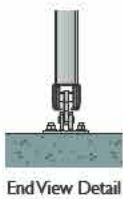

Viewed from secure side

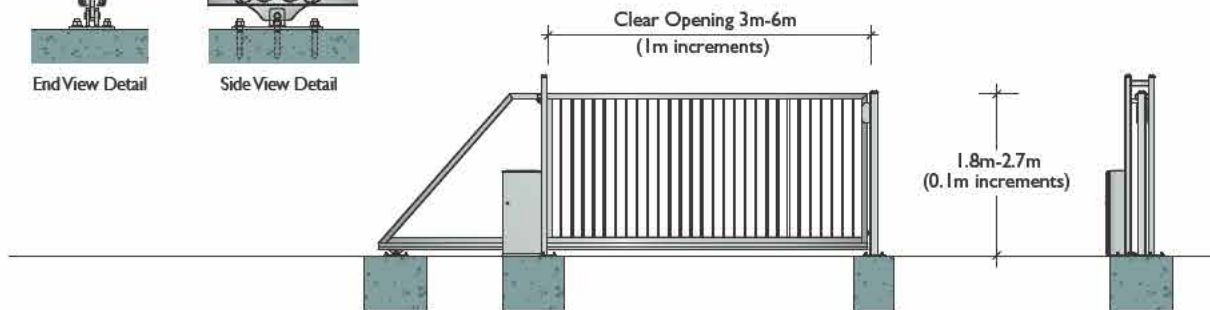

Intro	2
Gates	14
Track	20
Cantilever	30
Swing	40
Bi-fold	46
Boom	52
Options	76
General	82
Barriers	94
Blockers	100
Tyre Spikes	102
Pre-cast	106
Other	111
Pedestrian	114
Turnstiles	114
Gates & Doors	136
Fencing	142
Code Index	153

Undercarriage Option	Width Range	Height Range	Gate Infill	Top Extension
ICLU	3.0m-6.0m (1.0m †)	1.8m-2.7m (0.3m †)	Full Range *	Full Range *

† Increments available within width and height range. • Refer p19 for details of Gate Infills and Top Extensions.

**Security Undercarriage**

**Features**

- Centralised heavy duty roller assembly
- Concealed rollers
- Eliminates the need for gate extensions

**Applications**

- Dusty, sandy locations, areas of snow drift
- Insufficient room to install a running rail
- Sloping sites

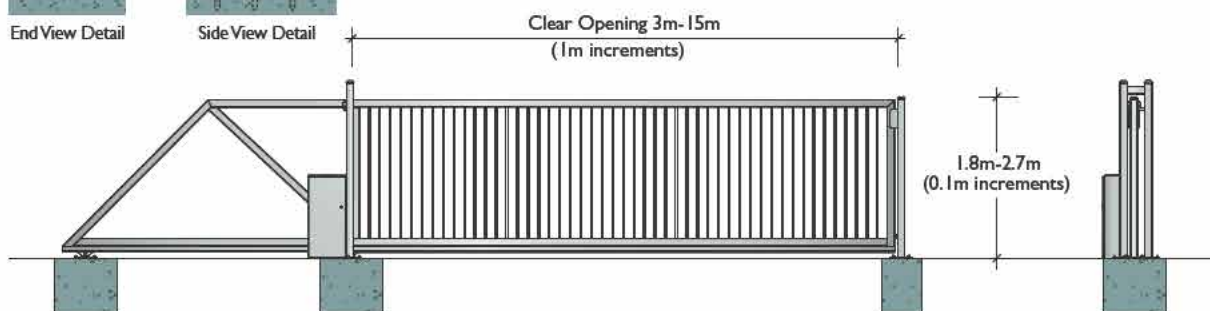
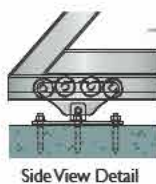
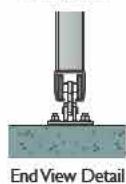

Undercarriage Option	Width Range	Height Range	Gate Infill	Top Extension
ICLUS	3.0m-15.0m (1.0m †)	1.8m-2.7m (0.3m †)	Full Range *	Full Range *

† Increments available within width and height range. • Refer p19 for details of Gate Infills and Top Extensions.

## Product Range > Gates > Cantilever DIY

☎ 1300 780 450



Leda's do-it-yourself gate is Australia's most popular gate for remote locations. It is supplied in knock-down kit form making it the ideal choice for long distance transportation or out-of-the-way locations.

Modular design allows for easy assembly, installation and commissioning in a single day.

Real advantages can be gained on sites with multiple gates, as a spare gate can be kept in stock for emergency situations when a gate needs to be replaced. The DIY gate means perimeter security and access can be restored within 24 hours.

### Features

- Economical
- Ideal for remote sites
- Low freight costs
- Four width options

### Fabrication

- Aluminium / steel sections
- Pickets Ø26mm @ 150mm spacings
- Beam 205mm x 285mm
- Tensioning wires 2 x Ø8mm



### Guiding System

- Double nylon wheels Ø90mm / Ø70mm
- Dust proof bearings
- Aluminium guard
- Aluminium wheel brackets (height adjustable)
- Wheel post 80mm x 60mm

*Ideal for remote locations.*

*Leda's detailed installation manual allows easy assembly and installation by 2 handymen.*



*Huge freight savings – a 6.0 metre gate stored on a single pallet (above), and a container loaded with 12 gates (right).*



*Easy assembly on site.*



*An Installation Kit with tools (**HGIS40**) is required to assemble these gates. Kits can be purchased or hired for a nominal fee which will be reimbursed on the Kit's return.*

1300 780 450

**Industrial  
DIY Kit Gate**

- Economical
- Ideal for remote sites
- Low freight costs
- Four width options

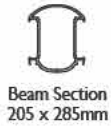

**Left or Right Hand  
Clear Opening**  
5.0m / 6.0m / 7.0m / 8.5m

**Typical  
End View**

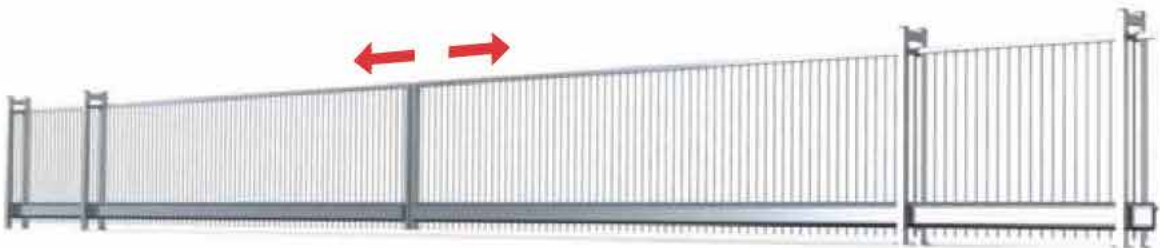
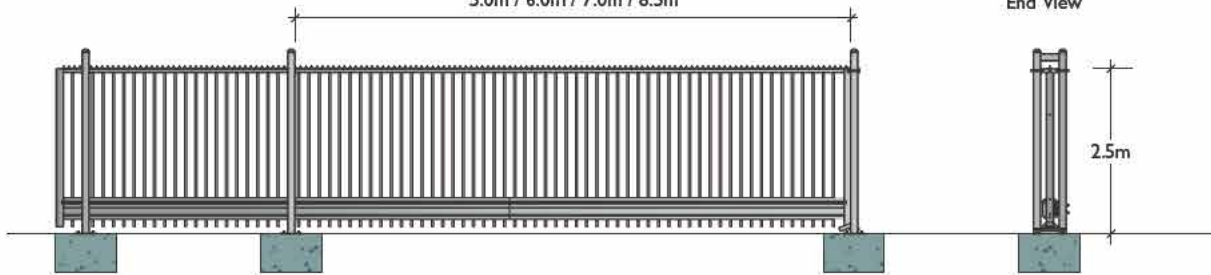

Viewed from  
secure side

**Bi-parting  
Clear Opening**  
10.0m / 12.0m / 14.0m / 17.0m

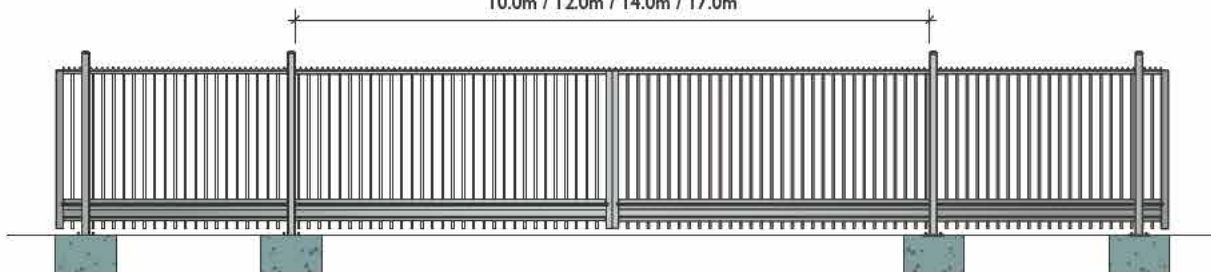

Intro	2
Gates	14
Track	20
Cantilever	30
Swing	40
Bi-fold	46
Boom	52
Options	76
General	82
<b>Barriers</b>	<b>94</b>
Blockers	100
Tyre Spikes	102
Pre-cast	106
Other	111
<b>Pedestrian</b>	<b>114</b>
Turnstiles	114
Gates & Doors	136
<b>Fencing</b>	<b>142</b>
<b>Code Index</b>	<b>153</b>

DIY Kit Gate	Width Range	Bi-Parting Width Range	Height Range	Gate Infill	Top Extension
LMC5025	5.0m	10.0m	2.5m	26mmØ Pickets	Shark Tooth
LMC6025	6.0m	12.0m	2.5m	26mmØ Pickets	Shark Tooth
LMC7025	7.0m	14.0m	2.5m	26mmØ Pickets	Shark Tooth
LMC8025	8.5m	17.0m	2.5m	26mmØ Pickets	Shark Tooth



☎ 1300 780 450

**Security**

**Fabrication  
Galvanised RHS**

Frame  
100 x 100



Bottom Rail  
150 x 100  
200 x 100  
(dependent upon span)



Running Rail  
150 x 100  
200 x 100  
(dependent upon span)

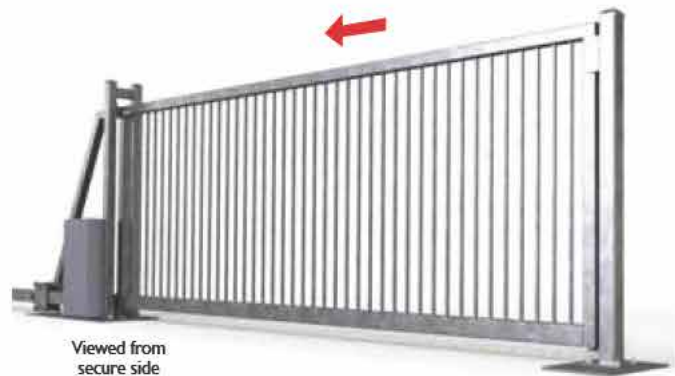

Viewed from secure side

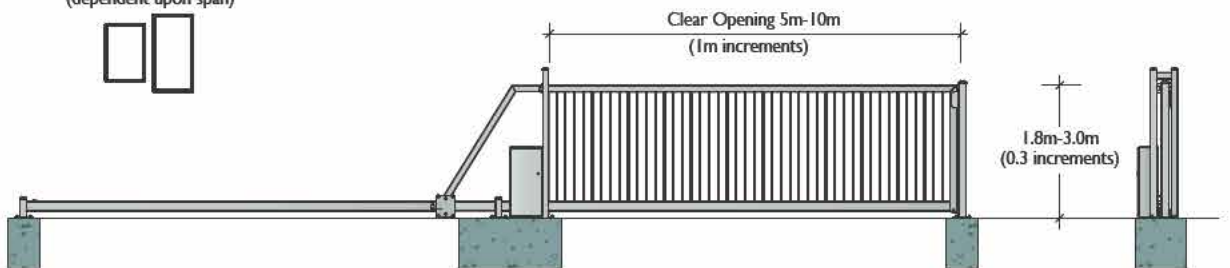

Cantilever Security	Width Range	Height Range	Gate Infill	Top Extension
<b>CLS</b>	5.0m-10.0m (1.0m †)	1.8m-3.0m (0.3m †)	Full Range *	Full Range *

† Increments available within width and height range. \* Refer p19 for details of Gate Infills and Top Extensions.

**Security**

**20m Span**

**Fabrication  
Galvanised RHS**

Frame  
250 x 250 x 6mm SHS



Back  
125 x 125 x 5mm SHS



Webbing  
50 x 50 x 4mm SHS



In an Australian first, Leda engineers have developed a new web design that will allow manufacture of cantilever gates with up to a 20 metre span.

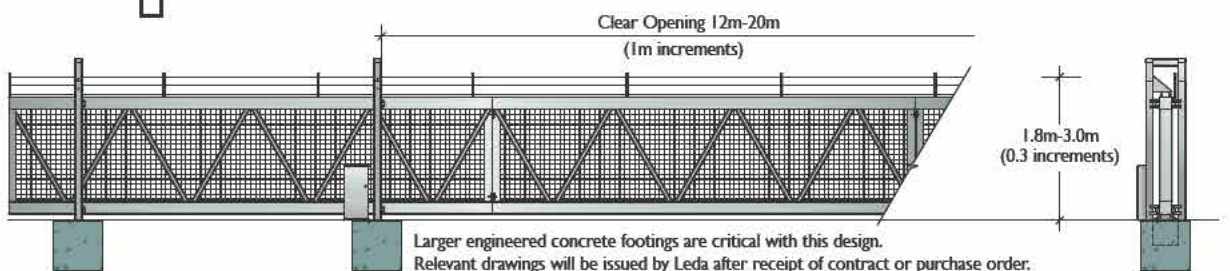
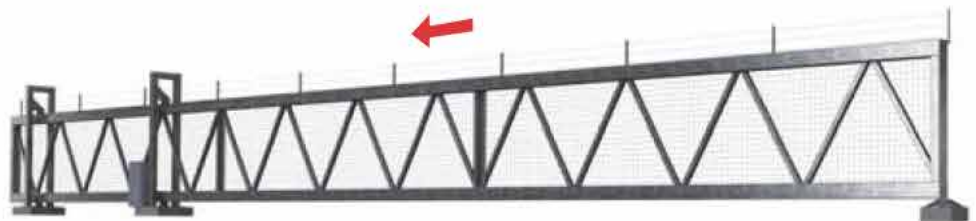

Cantilever Security	Width Range	Height Range	Gate Infill	Top Extension
<b>CLSL</b>	12.0m-20.0m (1.0m †)	1.8m-3.0m (0.3m †)	Welded Mesh	Full Range *

† Increments available within width and height range. \* Refer p19 for details of Top Extensions.

☎ 1300 780 450

**High Security**

**Fabrication Galvanised RHS**

Frame 100 x 100



Dual Bottom Rail 200 x 100



Running Rail 200 x 100



Viewed from secure side

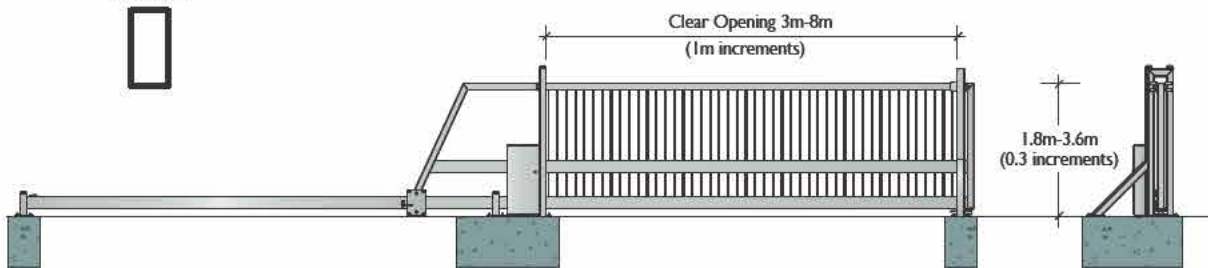

Intro	2
Gates	14
Track	20
Cantilever	30
Swing	40
Bi-fold	46
Boom	52
Options	76
General	82
Barriers	94
Blockers	100
Tyre Spikes	102
Pre-cast	106
Other	111
Pedestrian	114
Turnstiles	114
Gates & Doors	136
Fencing	142
Code Index	153

Cantilever High Security	Width Range	Height Range	Gate Infill	Top Extension
<b>CLSH</b>	5.0m-8.0m (1.0m †)	1.8m-3.6m (0.3m †)	Full Range *	Full Range *

† Increments available within width and height range. • Refer p19 for details of Gate Infills and Top Extensions.

**Anti-terrorist**

**CG12**



K12 Certified by US Department of State. (Equivalent to ASTM F2656-07 M50.) Manufactured under licence to APSG (American Physical Security Group).



Viewed from secure side

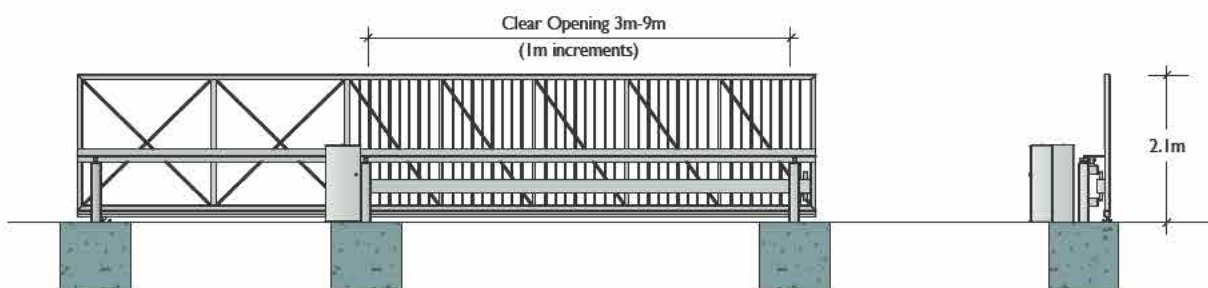

Cantilever Anti-terrorist	Width Range	Height Range	Gate Infill	Top Extension
<b>CG12</b>	3.0m-9.0m (1.0m †)	2.1m only	Full Range *	Full Range *

† Increments available within width range. • Refer p19 for details of Gate Infills and Top Extensions.

## Product Range > Gates > Cantilever > Configurations

☎ 1300 780 450



Cantilever gates continue to be the popular choice as a safe reliable gate design. They can be installed in a number of configurations, using bi-parting operation with options to include central pedestrian or smaller swing access gate.

Cantilever gates can also be installed with an overhead drive option for unrestricted operation in flood-prone areas or for alpine regions where drive mechanisms can be affected by compacting snow.



Roads and driveway entrances can be spanned up to 10 metres allowing clearance for central kerbs and road crowns. With less rolling resistance, cantilever gates can achieve faster, open and close speeds than track gates. Speeds can be adjusted and can be 'ramped' up or down at the end of the gate travel.



Heavy duty rollers and receiving rails together with a well-balanced design ensure smooth and efficient operation of all cantilever gates.

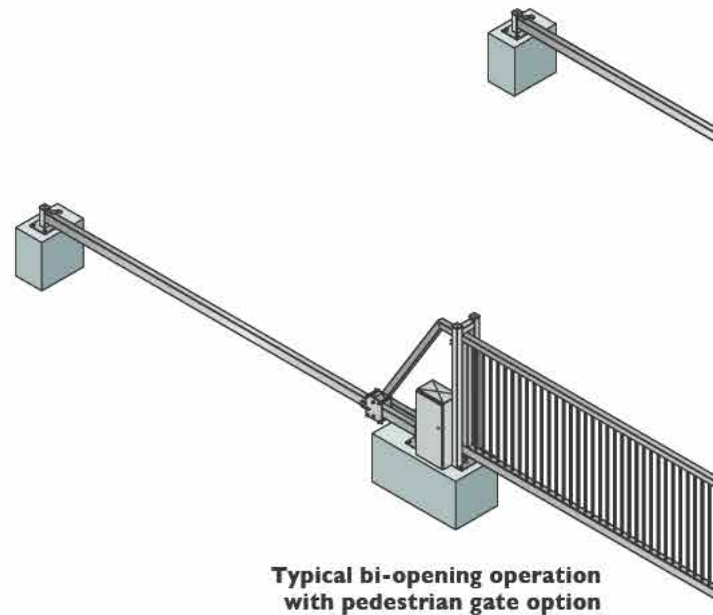

**Typical bi-opening operation with pedestrian gate option**

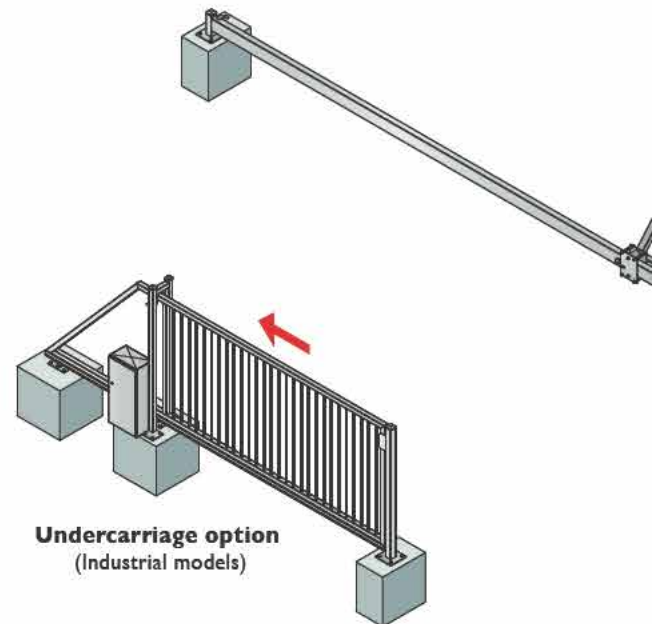

**Undercarriage option (Industrial models)**





☎ 1300 780 450

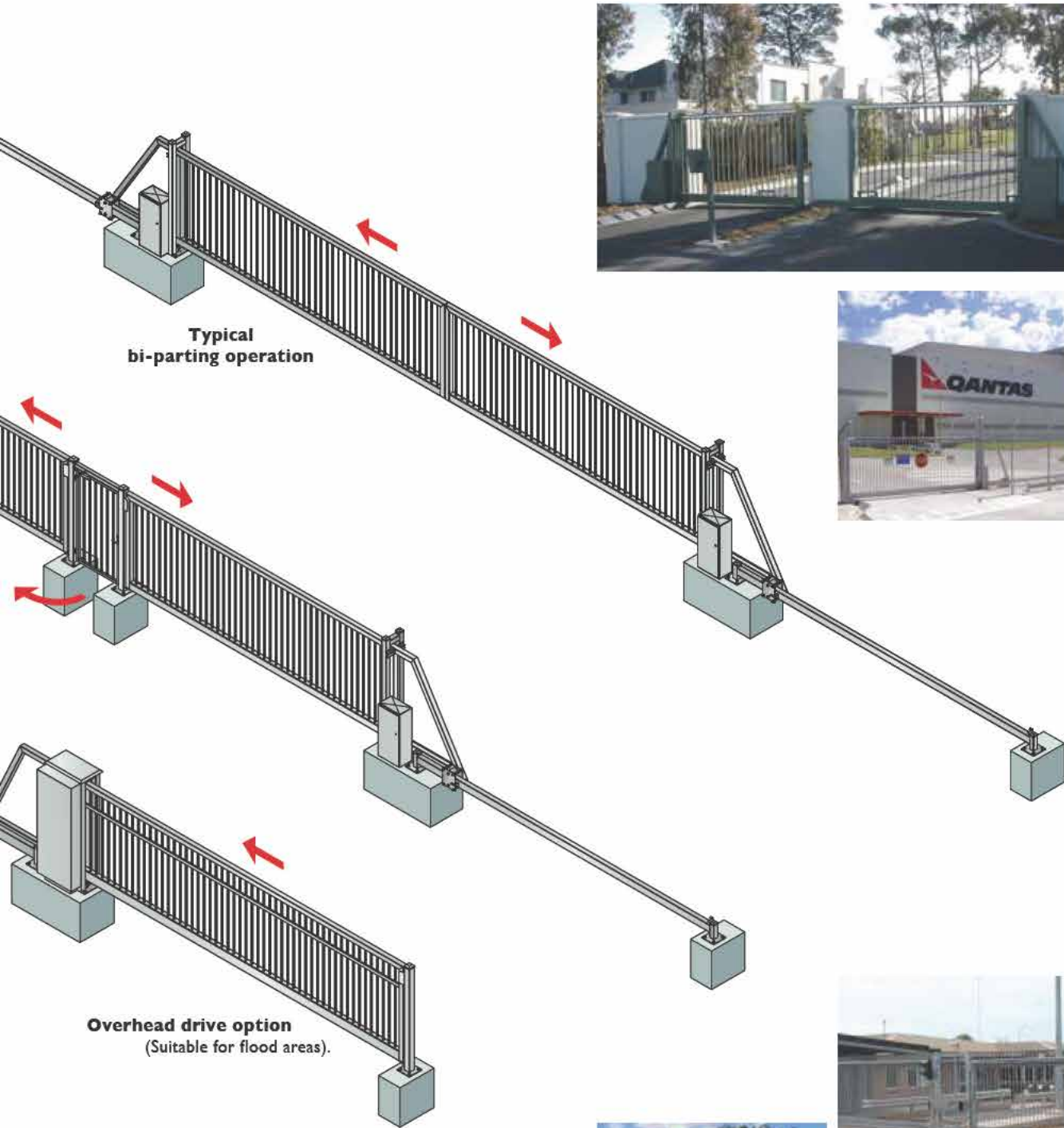

<b>Intro</b>	<b>2</b>
<b>Gates</b>	<b>14</b>
Track	20
Cantilever	30
Swing	40
Bi-fold	46
Boom	52
Options	76
General	82
<b>Barriers</b>	<b>94</b>
Blockers	100
Tyre Spikes	102
Pre-cast	106
Other	111
<b>Pedestrian</b>	<b>114</b>
Turnstiles	114
Gates & Doors	136
<b>Fencing</b>	<b>142</b>
<b>Code Index</b>	<b>153</b>



## Product Range > Gates > Swing

☎ 1300 780 450

Swing gates can be either single or dual leaf and can be operated manually or automated, with bi-fold options also available.

Swing gates normally require a level site across the driveway. They are also more prone to wind loadings so care should be taken in selecting the appropriate drive motor and gate infill.

There are four swing gate types, each providing options to make gate selection an easy task.

Steel sections (RHS) used during manufacture increase in size and wall thickness through the gate types to provide different levels of security.

Premier	<input type="checkbox"/>
Advantage	<input type="checkbox"/>
Industrial	<input type="checkbox"/>
Security	<input type="checkbox"/>
High Security	<input type="checkbox"/>
Anti Terrorist	<input type="checkbox"/>

With heavier steel sections used in Security models it is possible to extend the clear opening to 10 metres, however it does require substantial concrete footings for post support. For further technical information refer to your Leda sales office.

Single gates displayed are shown left hand opening, right hand opening gates are also available. All gates are viewed from the secure side.



**Premier**  
Single & Dual Opening



**Advantage**  
Single & Dual Opening



Duty Level		Code	Width Range	Height Range	Infill *	Top Extension *	Post Fixing
<b>Premier</b> <input type="checkbox"/>	Single	FPSS	2.7m only	1.8m/2.1m/2.4m	RHS Pickets	TC / TF	Fixed / Baseplate
	Dual	FPSD	5.4m only				
<b>Advantage</b> <input type="checkbox"/>	Single	ASS	2.0m-4.0m 1.0m increments †	1.8m/2.1m	RHS Pickets only	TC / TF only	Fixed / Baseplate
	Dual	ASD	4.0m-8.0m 2.0m increments †	1.8m / 2.1m	RHS Pickets only	TC / TF only	Fixed / Baseplate
<b>Industrial</b> <i>Redfern</i> <input type="checkbox"/> <i>Sports</i> <input type="checkbox"/> <i>Standard</i> <input type="checkbox"/>	Single	RSS	2.0m / 3.0m	1.8m / 2.1m	Flat Bar	N/a	Baseplate
	Dual	RSD	4.0m / 6.0m				
	Single	SSPOS	1.2m	0.8m	Flat Bar	N/a	Fixed
	Dual	SSPOD	2.4m				
<b>Security</b> <input type="checkbox"/>	Single	SWS	3.0m-6.0m 1.0m increments †	1.8m / 2.4m 0.3 increments †	Full Range	Full Range	Baseplate only
	Dual	ISD	6.0m-12.0m 2.0m increments †	1.8m / 2.4m 0.3 increments †	Full Range	Full Range	Baseplate only
<b>High Security</b> <input type="checkbox"/>	Single	SWSHS	4.0m-10.0m 1.0m increments †	2.1m / 3.0m 0.3 increments †	Full Range	Full Range	Baseplate only
	Dual	SWD	8.0m-20.0m 2.0m increments †	2.1m / 3.0m 0.3 increments †	Full Range	Full Range	Baseplate only
<b>Anti Terrorist</b>	Y Gate	SWSV	3.0m-6.0m 3.0m or 4.0m	2.5m only 2.1m only	RHS Pickets	Full Range	Fixed Insitu only
					RHS Pickets	TR / TB / TH	Fixed Insitu only

\* Refer p19 for details of Gate Infills and Top Extensions. † Increments available within width and height range.

1300 780 450

Full specification details for Leda gates can be downloaded as a PDF document, [www.ledasecurity.com.au/gates](http://www.ledasecurity.com.au/gates) > (gate type) > specification



**Industrial**  
Single & Dual Opening

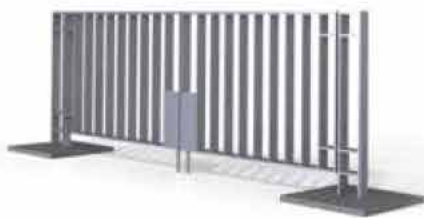

**Security**  
Single & Dual Opening

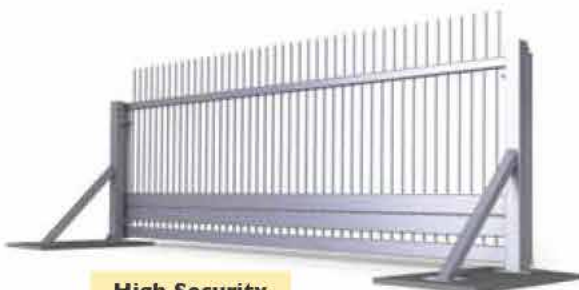

**High Security**  
Single Leaf Gate



**Anti Terrorist**  
Dual Opening 'V' Gate

Intro	2
Gates	14
Track	20
Cantilever	30
Swing	40
Bi-fold	46
Boom	52
Options	76
General	82
Barriers	94
Blockers	100
Tyre Spikes	102
Pre-cast	106
Other	111
Pedestrian	114
Turnstiles	114
Gates & Doors	136
Fencing	142
Code Index	153

Motor/s Optional	Lock Options		Raking Available	Finish		
	Manual Gate	Powered Gate		Hot Dip Gal	Powdercoat	Wet Spray
No	Padlockable Drop Bolt	n/a	No	Opt	Incl	Opt
Yes	Padlockable Drop Bolt	Magnetic Lock	No	Incl	Opt	Opt
Yes x 2	Padlockable Drop Bolt	Magnetic Lock	No	Incl	Opt	Opt
No	N/a	N/a	No	Incl	N/a	Opt
No	N/a	N/a	No	Incl	N/a	Opt
Yes	Padlockable Drop Bolt	Magnetic Lock	Yes	Incl	Opt	Opt
Yes x 2	Padlockable Drop Bolt	Magnetic Lock	Yes	Incl	Opt	Opt
Yes	Padlockable Drop Bolt	Magnetic Lock	Yes	Incl	Opt up to 6.5m only	Opt
Yes x 2	Padlockable Drop Bolt	Magnetic Lock	Yes	Incl	Opt up to 6.5m only	Opt
HS	n/a	Magnetic Lock	No	Incl	Opt	Opt
Yes x 2	n/a	Magnetic Lock	No	Incl	Opt	Opt



# Product Range > Gates > Swing

1300 780 450

## Premier

### Fabrication Galvanised RHS

Frame  
40 x 40



Bottom Rail  
40 x 40



Premier Gates utilise the same profile as Leda's popular Premier fencing design. They offer an economical solution for pedestrian or vehicular access, and while normally manually operated, they can be automated.

Viewed from  
secure side

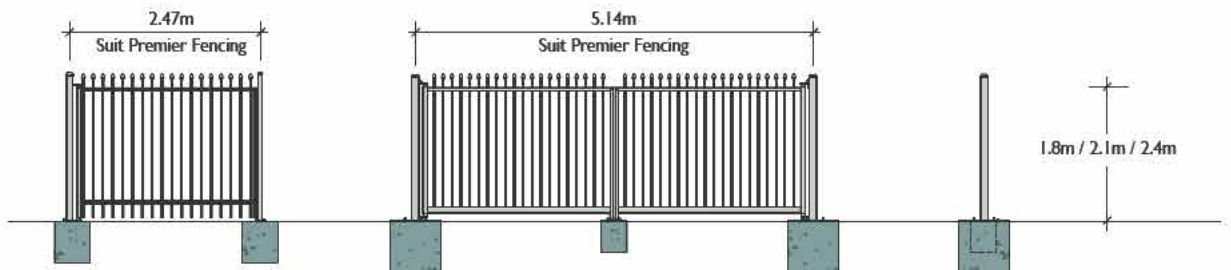

Swing Premier	Width Range	Height Range	Gate Infill	Top Extension
<b>FPSS Single Leaf</b>	2.47m only	1.8m / 2.1m / 2.4m	RHS Pickets only *	TC / TF only *
<b>FPSS Dual Leaf</b>	5.14m only	1.8m / 2.1m / 2.4m	RHS Pickets only *	TC / TF only *

\* Refer p19 for details of Gate Infills and Top Extensions.

## Advantage

### Fabrication Galvanised RHS

Frame  
50 x 50



Bottom Rail  
50 x 50 / 100 x 50  
(dependent upon span)



Viewed from  
secure side

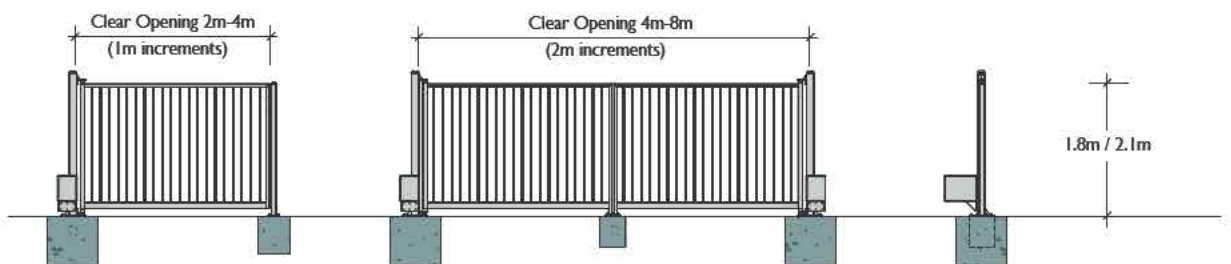

Swing Advantage	Width Range	Height Range	Gate Infill	Top Extension
<b>ASS Single Leaf</b>	2.0m-4.0m (1.0m †)	1.8m / 2.1 only	Full Range *	Full Range *
<b>ASD Dual Leaf</b>	4.0m-8.0m (2.0m †)	1.8m / 2.1 only	Full Range *	Full Range *

† Increments available within width range. \* Refer p19 for details of Gate Infills and Top Extensions.

1300 780 450

**Industrial Redfern**

**Fabrication**  
 Rails  
 75 x 75 RHS  
 125 x 75 RHS  
 (dependent upon span)

Pickets  
 65 x 8 Flat Bar

Viewed from secure side



Originally designed for sporting grounds and stadiums, the heavy construction makes them ideal for use with large crowds. The full height provides excellent perimeter security and can be installed individually or in a bank to allow for quick crowd disbursement.

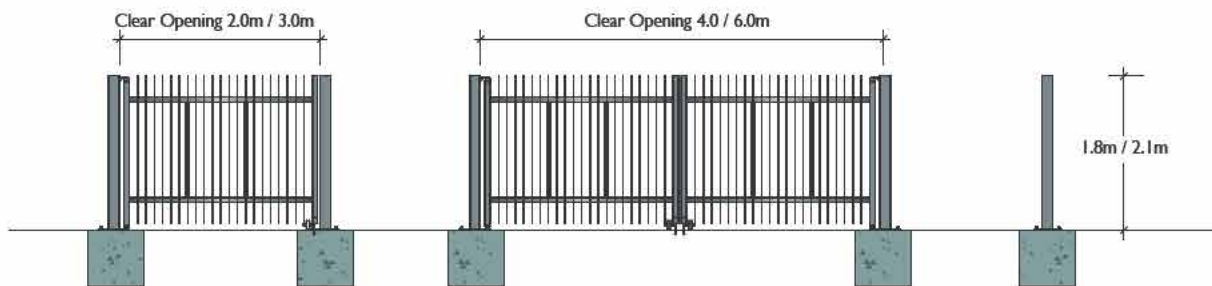

Swing Industrial Redfern >	Width Range	Height Range	Gate Infill
<b>RSS Single Leaf</b>	2.0m / 3.0m	1.8m / 2.1m	Flat Bar Picket
<b>RSD Dual Leaf</b>	4.0m / 6.0m	1.8m / 2.1m	Flat Bar Picket

> Matching Fencing available, refer p144 for details.

**Industrial Sports**

**Fabrication**  
 Rails  
 65 x 12 Flat bar

Pickets  
 65 x 8 Flat Bar

Viewed from secure side



The low height gate is for use with Leda's Sports fencing. It is designed for the pitch surround and provides security access to the playing area.

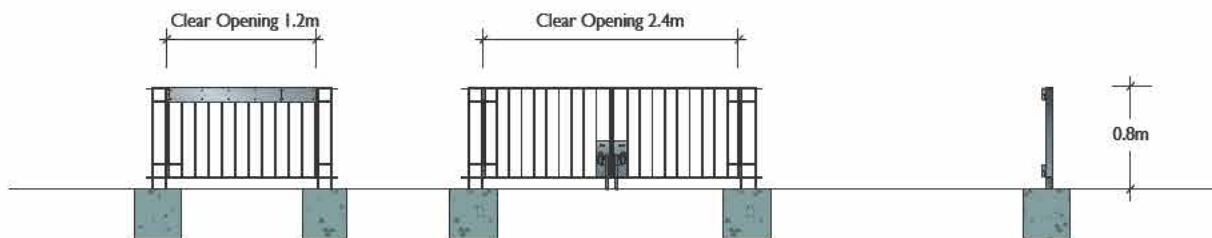

Swing Industrial Sports >	Width Range	Height Range	Gate Infill
<b>SSPOS Single Leaf</b>	1.2m	0.8m only	Flat Bar Picket
<b>SSPOD Dual Leaf</b>	2.4m	0.8m only	Flat Bar Picket

> Matching Fencing available, refer p144 for details.

Intro	2
Gates	14
Track	20
Cantilever	30
Swing	40
Bi-fold	46
Boom	52
Options	76
General	82
<b>Barriers</b>	<b>94</b>
Blockers	100
Tyre Spikes	102
Pre-cast	106
Other	111
<b>Pedestrian</b>	<b>114</b>
Turnstiles	114
Gates & Doors	136
<b>Fencing</b>	<b>142</b>
<b>Code Index</b>	<b>153</b>

# Product Range > Gates > Swing

☎ 1300 780 450

## Industrial

### Fabrication Galvanised RHS

Frame  
75 x 75



Bottom Rail  
75 x 75 / 125 x 75  
(dependent upon span)

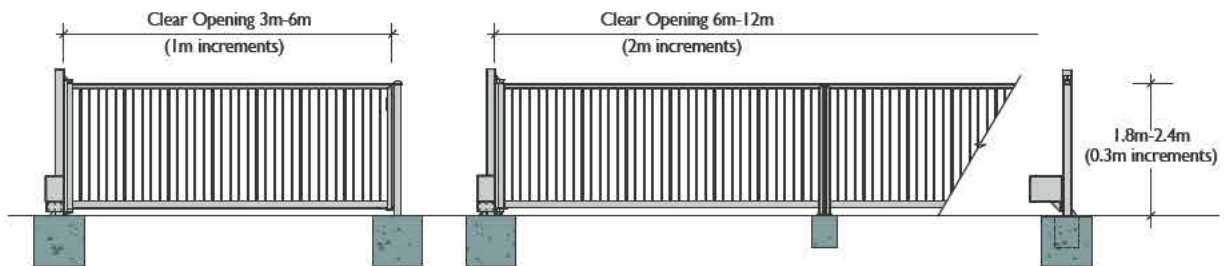

Swing Industrial	Width Range	Height Range	Gate Infill	Top Extension
ISS Single Leaf	3.0m-6.0m (1.0m †)	1.8m-2.4 (0.3m †)	Full Range *	Full Range *
ISD Dual Leaf	6.0m-12.0m (2.0m †)	1.8m-2.4 (0.3m †)	Full Range *	Full Range *

† Increments available within width and height range. \* Refer p19 for details of Gate Infills and Top Extensions.

## Security

### Fabrication Galvanised RHS

Frame  
100 x 100



Bottom Rail  
100 x 100  
150 x 100  
200 x 100

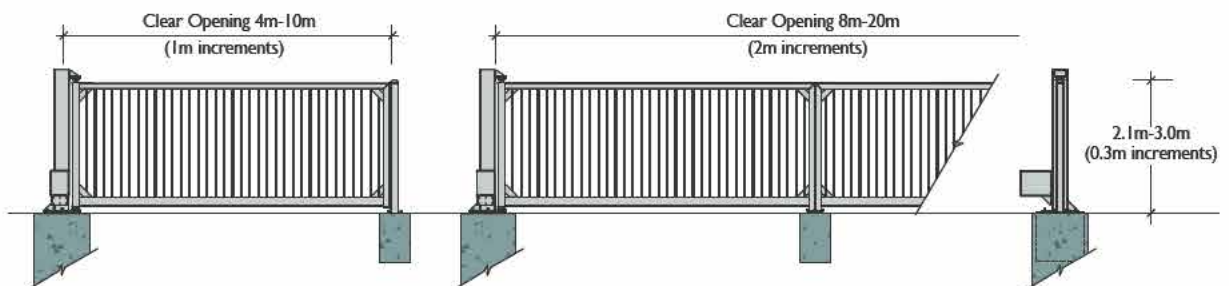

Swing Security	Width Range	Height Range	Gate Infill	Top Extension
SWS Single Leaf	4.0m-10.0m (1.0m †)	2.1m-3.0 (0.3m †)	Full Range *	Full Range *
SWD Dual Leaf	8.0m-20.0m (2.0m †)	2.1m-3.0 (0.3m †)	Full Range *	Full Range *

† Increments available within width and height range. \* Refer p19 for details of Gate Infills and Top Extensions.



1300 780 450

**High Security**  
Single Leaf

**ENGINEERED SOLUTION**

2.5 tonnes @ 40km/h

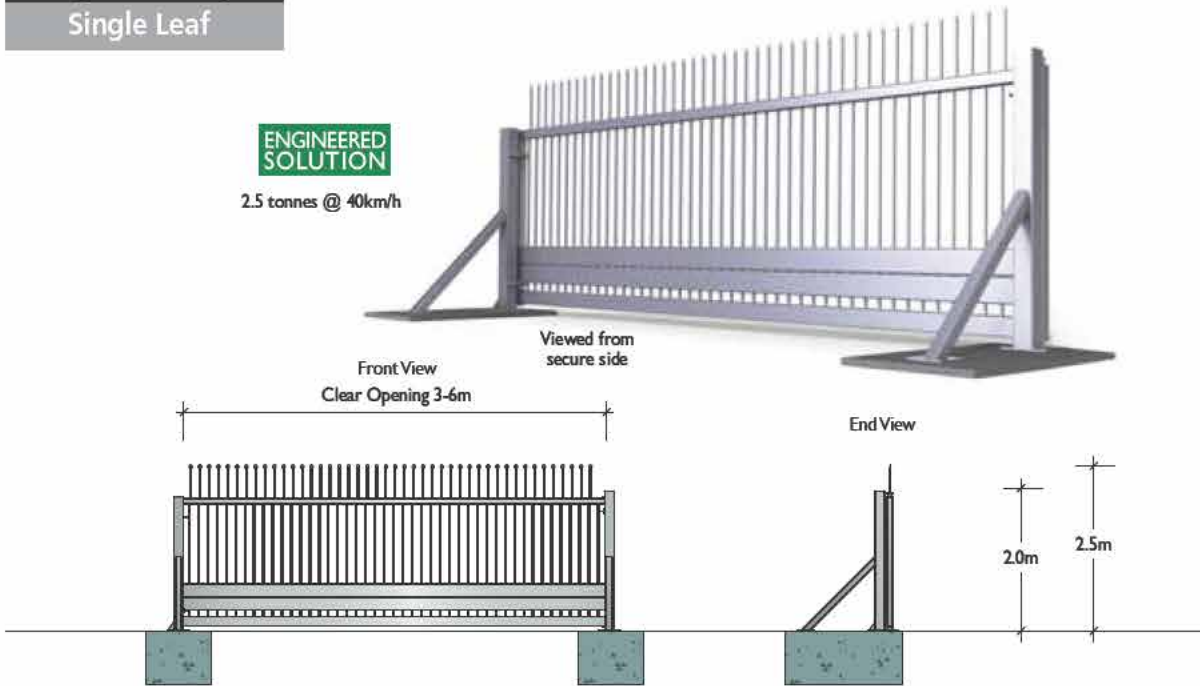

Swing High Security	Width Range	Height Range	Gate Infill	Top Extension
<b>SWSHS</b>	3.0m-6.0m (1.0m †)	2.5m only	RHS Pickets •	Full Range •

† Increments available within width and height range. • Refer p19 for details of Gate Infills and Top Extensions

**Anti Terrorist**  
'V' Gate

**PAS68 TESTED**

The Leda / Broughton 'V' Gate is a high security anti-terrorist product that is PAS68 tested and certified, achieving a classification of V/7500 (N3) 80/90 : 0/0

- Rapid open and close
- Zero penetration of site by attack vehicle
- No significant damage from attack vehicle
- Ultra-high impact capability
- Minimal site clearance required
- Shallow footing design

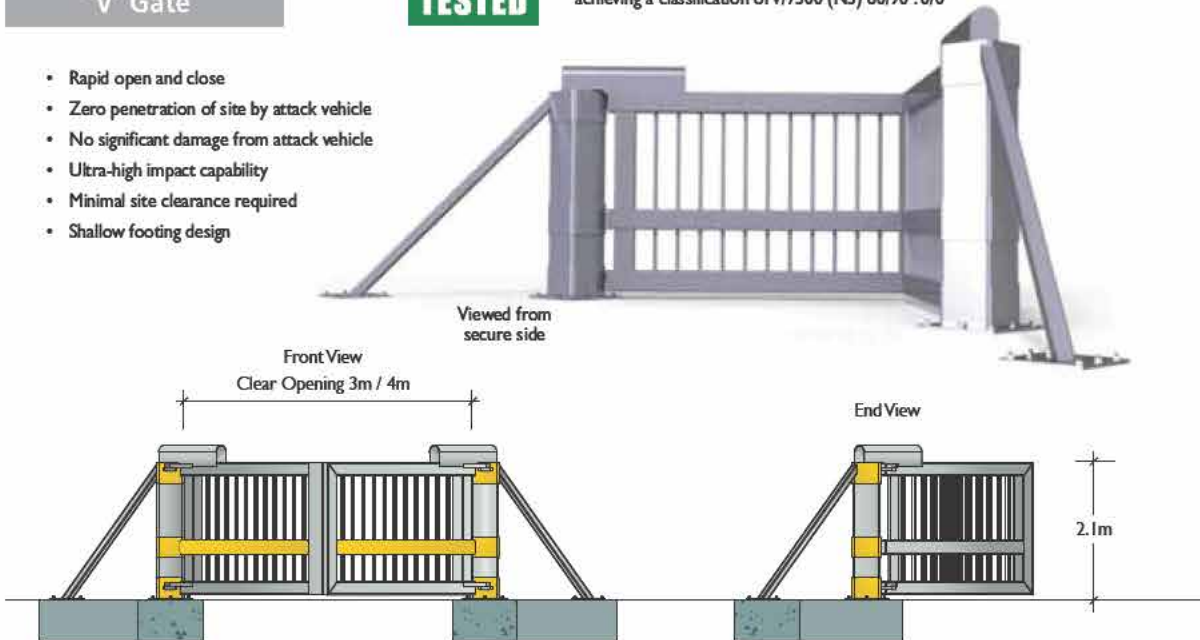

Swing Anti Terrorist	Width Range	Height Range	Gate Infill	Top Extension
<b>SWSV30</b>	3.0m only	2.1m only	RHS Pickets •	TR / TB / TH •
<b>SWSV40</b>	4.0m only	2.1m only	RHS Pickets •	TR / TB / TH •

• Refer p19 for details of Gate Infills and Top Extensions.

Intro	2
Gates	14
Track	20
Cantilever	30
Swing	40
Bi-fold	46
Boom	52
Options	76
General	82
<b>Barriers</b>	<b>94</b>
Blockers	100
Tyre Spikes	102
Pre-cast	106
Other	111
<b>Pedestrian</b>	<b>114</b>
Turnstiles	114
Gates & Doors	136
<b>Fencing</b>	<b>142</b>
<b>Code Index</b>	<b>153</b>

## Product Range > Gates > Bi-fold

☎ 1300 780 450

Bi-fold gates are a relatively new design having initially emerged in Europe as an alternative for vehicular access control for commercial buildings and industrial sites. Leda was the first Australian company to design and manufacture the gates to meet Australian conditions and building codes.

Quick opening and closing speeds allow the gates to operate in high-traffic applications while providing the security of a perimeter gate. They can be tailored to suit various widths and heights and are designed to meet all relevant OH&S requirements. To minimise potential accidents, traffic lights, photoelectric (PE) beams and safety bump strips are recommended,



They provide a higher level of security than boom gates, are much faster than traditional roller shutter doors and can be operated by all major access control systems. When not in use they completely secure the entry/exit access point to all vehicle and pedestrian intruders.

Leda's bi-fold gates are available in 4 duty levels.

Advantage
Industrial
Security
High Security

Trackless models require two drive motors which while operating individually are electronically controlled to operate in tandem.



### Features

- High Speed – reduces delays on entering and leaving
- 100% Duty Cycle – for continuous operation
- Security – superior to boom gates and roller shutters
- Space – tracks within its own confines

### Applications

- Apartment Buildings
- Car Parks
- Commercial Buildings
- Shopping Malls
- Industrial Sites

### Safety & Security

Leda Bi-fold Gates have been designed with safety and security as a high priority. They are also engineered for toughness and robustness and have been thoroughly tested to withstand intensive and continual use.

Traffic lights are installed as standard equipment to minimise potential accidents. They provide a positive signal when to proceed or stop – important for drivers unfamiliar with how the gates operate.

### Standard & Custom Sizes

Gates are tailored to suit site restraints and openings. While most are designed for single lane operations, they can be manufactured up to 6m in height and width to cater for large commercial and industrial applications.

Duty Level		Code	Width Range	Height Range	Gate Infill •
Advantage Trackless	Single Sided	BFGST	2.0m / 3.0m only	1.8m / 2.1m / 2.4m only	Refer p47
	Double Sided	BFGDT	4.0m-6.0m 1.0m increments †	1.8m / 2.1m / 2.4m only	Refer p47
Industrial Overhead Track	Single Sided	BFGSS	2.0m / 3.0m only	2.1m-4.0m 0.3m increments †	Refer p47
	Double Sided	BFGDS	4.0m-6.0m 1.0m increments †	2.1m-4.0m 0.3m increments †	Refer p47
Overhead Track High Speed *	Single Sided	BFGSF	2.0m / 3.0m only	2.1m-3.0m 0.3m increments †	Refer p47
	Double Sided	BFGDF	4.0m-6.0m 1.0m increments †	2.1m-3.0m 0.3m increments †	Refer p47
Security Trackless HS *	Double Sided	ABFDT	4.0m / 6.0m only	2.0m / 2.5m only	Pickets
High Security Trackless	Single Sided	VG01	3.0m-5.0m 1.0m increments †	2.1m / 2.4m only	Ø20NB Pickets

• Refer p47 for details of Bi-fold Gate Infills. † Increments available within width and height range.

\* For high speed units, extra safety devices must be used to stop the gate (s) opening when an obstruction is detected.

1300 780 450

Full specification details for Leda gates can be downloaded as a PDF document, [www.ledasecurity.com.au/gates](http://www.ledasecurity.com.au/gates) > (gate type) > specification



**Advantage**  
Trackless  
Double-sided



**Industrial**  
Overhead Track  
Double-sided



**Security**  
Trackless High Speed  
Double-sided



**High Security**  
Trackless  
Single or double-sided

**Infill Options**

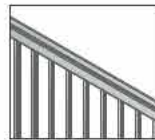

Standard Pickets

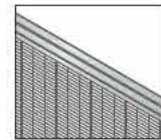

Mesh

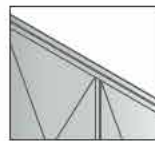

Solid Colorbond®

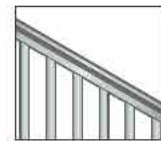

Large Pickets

Intro	2
Gates	14
Track	20
Cantilever	30
Swing	40
Bi-fold	46
Boom	52
Options	76
General	82
Barriers	94
Blockers	100
Tyre Spikes	102
Pre-cast	106
Other	111
Pedestrian	114
Turnstiles	114
Gates & Doors	136
Fencing	142
Code Index	153

Motor/s Included	Lock Options	Finish		
		Hot Dip Gal	Powdercoat	Wet Spray
Standard 8-10 seconds	Magnetic Lock at receiving post	Included	Standard	Optional
Standard x 2 8-10 seconds	Magnetic Locks at leaf hinge points	Included	Standard	Optional
Standard 8-10 seconds	Magnetic Lock at receiving post or in head	Included	Standard	Optional
Standard x 2 8-10 seconds	Magnetic Locks mounted to head section	Included	Standard	Optional
Standard 3-5 seconds	Magnetic Lock at receiving post or in head	Included	Standard	Optional
Standard x 2 3-5 seconds	Magnetic Locks mounted to head section	Included	Standard	Optional
1m / second	Solid Locking	Included	Standard	Optional
Standard 8-10 seconds	Solid Locking	Included	-	Optional



# Product Range > Gates > Bi-fold

☎ 1300 780 450

## Trackless Advantage

Automatic or Manual

Trackless option eliminates the need for overhead track, however the design requires 2 drive motors (one on each side) to operate.

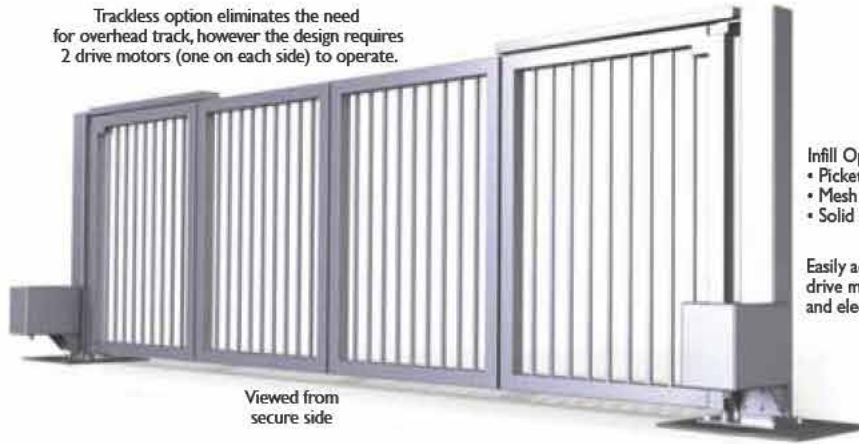

- Infill Options
- Pickets (Standard)
  - Mesh
  - Solid Colorbond®

Easily accessible drive motors and electronics

Viewed from secure side



Tracks within its own confines

Safety bump strips

Automatic operation may not be required on all sites particularly where there might be occasional or minimum openings per day. Contact Leda for further information.

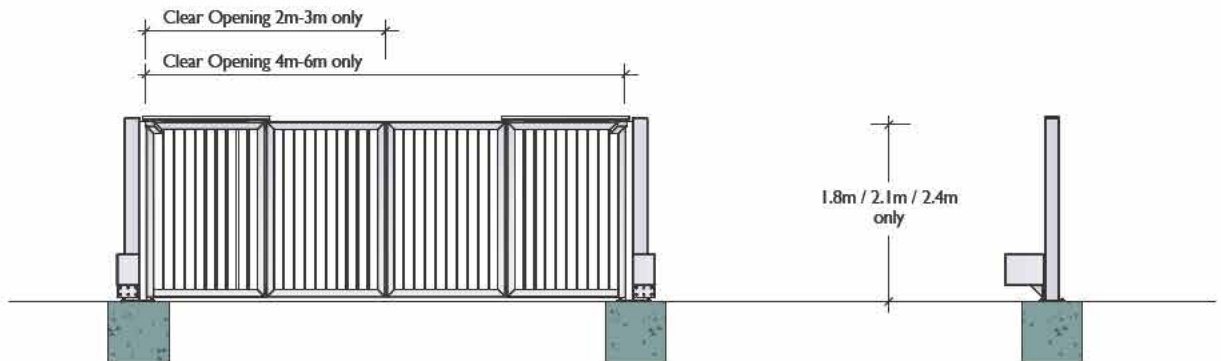

Bi-fold Advantage	Trackless	Width Range	Height Range	Gate Infill •
<b>BFGS T</b>	<b>Single Sided</b>	2.0m-3.0m only	1.8m / 2.1m / 2.4m only	Refer p47
<b>BFGD T</b>	<b>Double Sided</b>	4.0m-6.0m only	1.8m / 2.1m / 2.4m only	Refer p47

• Refer p47 for details of Gate Infills.

☎ 1300 780 450

**Overhead Track**

**Industrial**

Opening Speed  
Approx. 12 seconds

Viewed from  
secure side



Clear Opening 2m-3m only

Clear Opening 4m-6m only

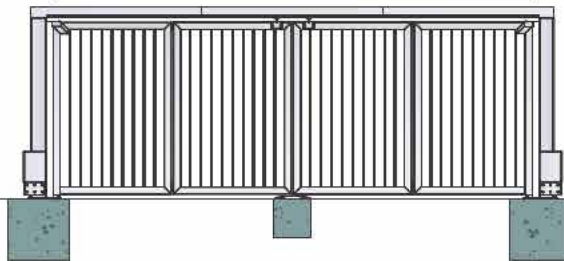

2.1m-4.0m  
0.3 increments

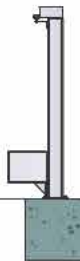

Bi-fold Industrial	Overhead	Width Range	Height Range	Gate Infill •
<b>BFGS S</b>	<b>Single Sided</b>	2.0m-3.0m only	2.1m-4.0m (0.3m †)	Refer p47
<b>BFGD S</b>	<b>Double Sided</b>	4.0m-6.0m only	2.1m-4.0m (0.3m †)	Refer p47

• Refer p47 for details of Gate Infills. † Increments available within height range.

Intro	2
Gates	14
Track	20
Cantilever	30
Swing	40
Bi-fold	46
Boom	52
Options	76
General	82
<b>Barriers</b>	<b>94</b>
Blockers	100
Tyre Spikes	102
Pre-cast	106
Other	111
<b>Pedestrian</b>	<b>114</b>
Turnstiles	114
Gates & Doors	136
<b>Fencing</b>	<b>142</b>
<b>Code Index</b>	<b>153</b>

**Overhead Track HS**

**Industrial**

High Speed  
Opening Speed  
Approx. 6 seconds

Viewed from  
secure side



Clear Opening 2m-3m only

Clear Opening 4m-6m only

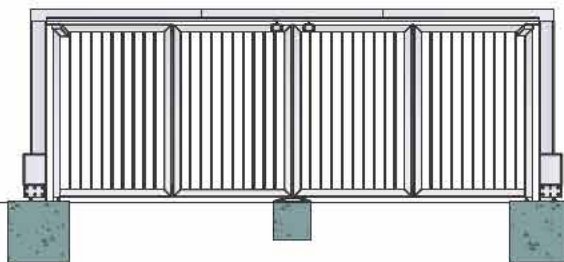

2.1m-3.0m  
0.3 increments

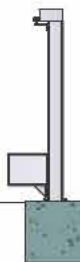

Bi-fold Industrial	Overhead High Speed	Width Range	Height Range	Gate Infill •
<b>BFGS F</b>	<b>Single Sided</b>	2.0m-3.0m only	2.1m-3.0m (0.3m †)	Refer p47
<b>BFGD F</b>	<b>Double Sided</b>	4.0m-6.0m only	2.1m-3.0m (0.3m †)	Refer p47

• Refer p47 for details of Gate Infills. † Increments available within height range.

# Product Range > Gates > Bi-fold

© 1300 780 450

## Trackless Security

### Fabrication

- Columns  
300 x 400 x 10mm RHS
- Leaf Frame  
80 x 80 x 3mm SHS
- Pickets  
40 x 40 x 2mm SHS

### Finish

Galvanised / epoxy paint  
in a range of standard RAL colours

Viewed from  
secure side



Manufactured in Europe, this trackless high speed gate is considered to be state-of-the-art technology in bi-fold gate design. The Almagate bi-fold gate surpasses many existing systems as it operates without a top and bottom track making it ideal for harsh environments.

The leaves swing behind the pillars when open allowing the entire clearance width to be available, and when in the fully closed position, a specially recessed catch makes it highly resistant to ram-raiding.

The gate operates at fast opening and closing speeds of 1 metre per second, powered by electric motors located in the column housing, and designed with a 'plug and play' principle that allows easy and quick replacement of parts by one person without having to dismantle the gate.

While the gate is not inexpensive, it is considered to be the best bi-fold gate available worldwide.

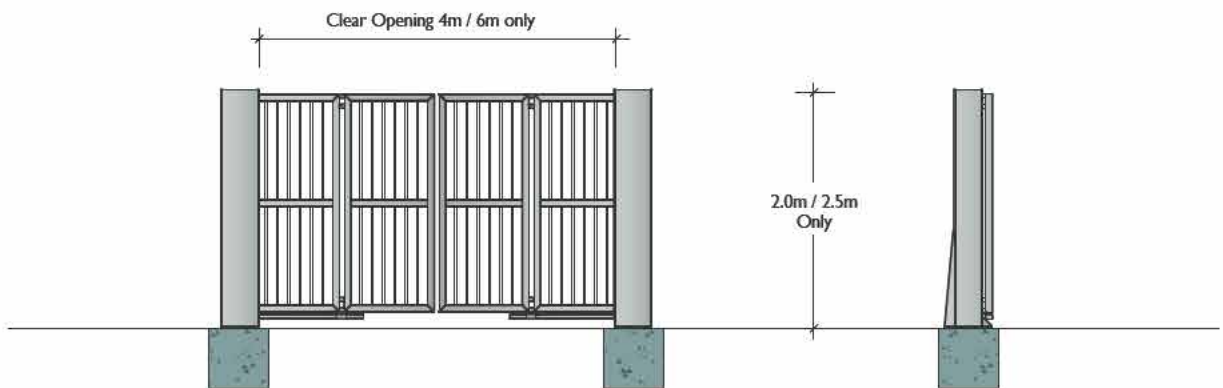

Bi-fold Industrial	Trackless High Speed	Width Range	Height Range	Gate Infill
ABFDT	Double Sided	4.0m / 6.0m	2.0m / 2.5m	40 x 50 x 2mm RHS



1300 780 450

**Trackless**  
**High Security**

Viewed from secure side



This Leda gate has been engineered to obtain the maximum impact resistance and security possible from a bi-fold gate of its size. Key engineering features include 3 layers of wire rope bracing located at the base of the gate to maximise impact resistance, it also only requires 500mm shallow mount concrete footings, making it easier to retro-install on existing sites. The gate has 2 leaves that operate in tandem via a chain drive mechanism.

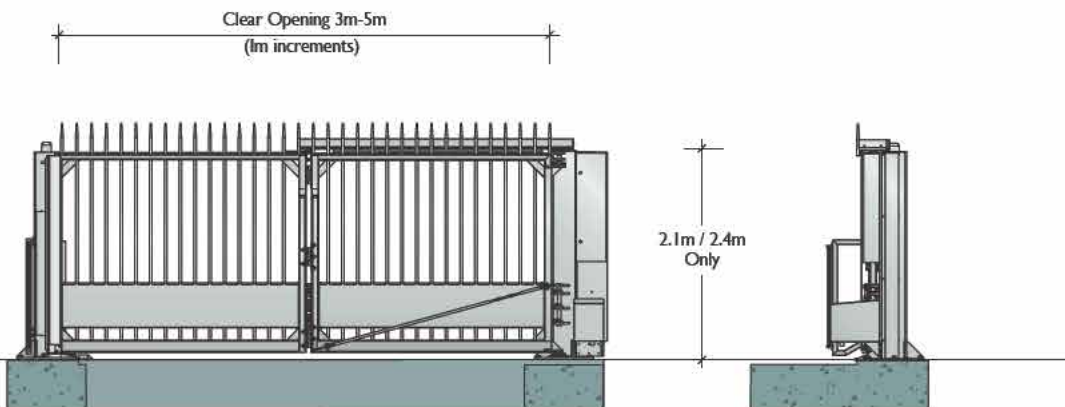

<b>Intro</b>	<b>2</b>
<b>Gates</b>	<b>14</b>
Track	20
Cantilever	30
Swing	40
Bi-fold	46
Boom	52
Options	76
General	82
<b>Barriers</b>	<b>94</b>
Blockers	100
Tyre Spikes	102
Pre-cast	106
Other	111
<b>Pedestrian</b>	<b>114</b>
Turnstiles	114
Gates & Doors	136
<b>Fencing</b>	<b>142</b>
<b>Code Index</b>	<b>153</b>

Bi-fold High Security		Width Range	Height Range	Gate Infill
<b>VG01</b>	<b>Single Sided</b>	3-0-5.0m (1.0m increments)	2.1m / 2.4m only	20NB Pickets

## Product Range > Gates > Boom

☎ 1300 780 450

Leda offers Australia's largest range of vehicle access control boom gates, ensuring the appropriate product can be selected and installed for a diversity of applications.

Leda has supplied and installed thousands of units across Australia, the majority of which, Leda's technicians continue to service and maintain.

Boom gates fall into three main categories:

- **Vertical**
- **Swing**
- **Sliding**

While the majority of boom gates are automated there are a limited number of manually operated models in the vertical and swing ranges.

Advantage	<input type="radio"/>	<input type="checkbox"/>
Industrial	<input type="radio"/>	<input type="checkbox"/>
Security	<input type="radio"/>	<input type="checkbox"/>
High Security	<input type="radio"/>	<input type="checkbox"/>

Boom gates can perform the majority of access control functions for regulating vehicular traffic in applications such as car parks through to high security installations. Boom gates can be integrated with other perimeter security devices such as barrier systems, retractable bollards, and tyre spikes to achieve higher levels of security.

Gates displayed are shown left hand opening, viewed from the secure side. Right hand opening gates are also available.

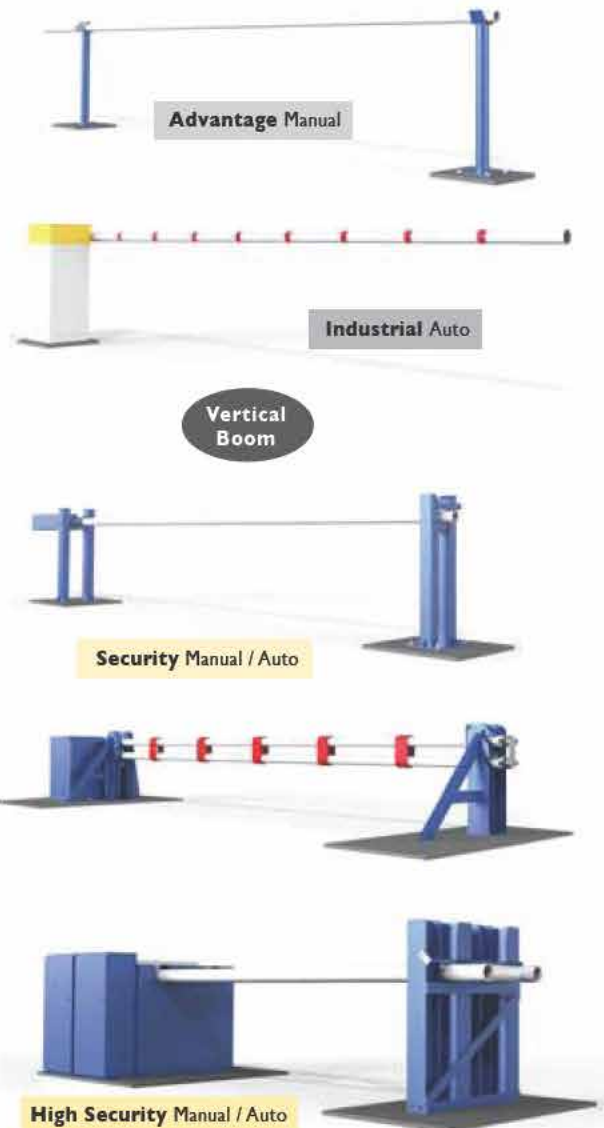

Boom Type	Duty Level		Code	Width Range	Height Range	Post Fixing	
Vertical	Advantage	Manual	MBGB/F	3.0m-7.0m (0.5m <sup>†</sup> )	0.9m / 1.0m	Fixed / Baseplate	
	Industrial	Auto	TMH60	3.0m-6.0m (0.5m <sup>†</sup> )	1.0m	n/a	
			TMH80	7.0m-8.0m (0.5m <sup>†</sup> )	1.0m	n/a	
	Security	Auto	TMH120	10.0m-12.0m (0.5m <sup>†</sup> )	1.0m	n/a	
			Auto 24V	TMH3024 / 5024	3.0m / 5.0m	0.87m	n/a
			Auto Portable	TMHP39	3.0m-9.0m	0.9m	n/a
	High Security	Auto	Manual	BR420	3.0m-5.0m (0.5m <sup>†</sup> )	0.9m / 1.0m	Fixed / Baseplate
MBGSB/F				3.0m or 4.5m only	0.9m / 1.0m	Fixed only	
Auto		Manual	ANB	3.0m-6.0m (0.5m <sup>†</sup> )	0.925m	Baseplate only	
			D941/D942/D943	3.0m or 4.5m only	0.9m / 1.0m	Fixed only	
Swing	Advantage	Single/Dual	MSG/DSG	2.0m-4.5m / x 2 (0.5m <sup>†</sup> )	1.0m	Fixed / Baseplate	
	Industrial	Single/Dual	IMSG/IDSG	2.0m-6.0m / x 2 (0.5m <sup>†</sup> )	1.0m	Fixed / Baseplate	
	Security	Single/Dual	SK010S/SK010D	8.0m / x 2	1.2m	Fixed	
		Single	CSG	4.0m-6.0m (1.0m <sup>†</sup> )	0.92m	Fixed	
Sliding	Industrial	Auto	ITSMBA	3.0m-7.0m (0.5m <sup>†</sup> )	0.9m / 1.0m	Fixed / Baseplate	
	Security	Auto	TSMBA	3.0m-9.0m (0.5m <sup>†</sup> )	0.9m / 1.0m	Fixed / Baseplate	
		Auto	TSMBAH	3.0m-9.0m (0.5m <sup>†</sup> )	0.9m / 1.0m	Fixed	
	High Security	Auto	TSMBAXH	3.0m-9.0m (0.5m <sup>†</sup> )	0.9m / 1.0m	Fixed	

<sup>†</sup> Increments available within width range.

# Product Range > Gates > Boom

1300 780 450

Full specification details for Leda gates can be downloaded as a PDF document, [www.ledasecurity.com.au/gates](http://www.ledasecurity.com.au/gates) > (gate type) > specification



<b>Intro</b>	<b>2</b>
<b>Gates</b>	<b>14</b>
Track	20
Cantilever	30
Swing	40
Bi-fold	46
Boom	52
Options	76
General	82
<b>Barriers</b>	<b>94</b>
Blockers	100
Tyre Spikes	102
Pre-cast	106
Other	111
<b>Pedestrian</b>	<b>114</b>
Turnstiles	114
Gates & Doors	136
<b>Fencing</b>	<b>142</b>
<b>Code Index</b>	<b>153</b>

Other Options	Auto Available	Manual Available	Locking Options	Finish		
				Hot Dip Gal	Powdercoat	Wet Spray
	No	Standard	Padlock at weight	No cost option	No cost option	Opt
	Standard	No	n/a		Standard	
	Standard	No	n/a		Standard	
	Standard	No	n/a		Standard	
	Standard	No	n/a		Standard	
	No	Standard	Padlock at weight	No cost option	No cost option	Opt
	Standard	Yes	n/a			
	Standard	No	n/a		Standard	
	Yes		Padlock at post	No cost option	No cost option	Opt
Dual Centre Post 1	No	Standard	Padlock at post	Included	Opt	Opt
Dual Centre Post 1	No	Standard	Padlock at post	Included	Opt	Opt
Dual Centre Post 1	No	Standard	Padlock at post	Included	Opt	Opt
	Standard	Yes	n/a	n/a	n/a	n/a
Boom Shroud 2	Standard	Yes	n/a	No cost option	No cost option	Opt
Boom Shroud 2	Standard	Yes 3	n/a	No cost option	No cost option	Opt
Boom Shroud 2	Standard	Yes 2	n/a	No cost option	No cost option	Opt
Boom Shroud 2	Standard	Yes 2	n/a	No cost option	No cost option	Opt

1. Removable centre post (Securapost bollard SP90R). 2. Boom shroud when in open position, refer p75. 3. Not recommended.



## Product Range > Gates > Vertical Boom

☎ 1300 780 450

Leda manufactures the largest and most comprehensive range of boom gates in Australia, catering for applications as simple as vehicle access control in public car parks to the more secure installations of heavy industrial sites and government installations.

- Manual and automatic models
- 100% Duty Cycle – for continuous operation
- 12 month warranty
- Range of options and accessories
- Suited for most car parks and low-medium vehicle access applications
- Commercial and industrial areas

The combination of Leda's proven and reliable electric motors and lever mechanism, represents a very simple and extremely reliable drive system. It allows for short opening and closing times without the boom arm bouncing at the end position. The lever arm system locks the boom at both end positions without the need for a receiving post.

Factory-set counterweights are designed in all boom arms, allowing easy manual lift of automatic booms in the event of power outages.

### Manual Vertical Boom Gates

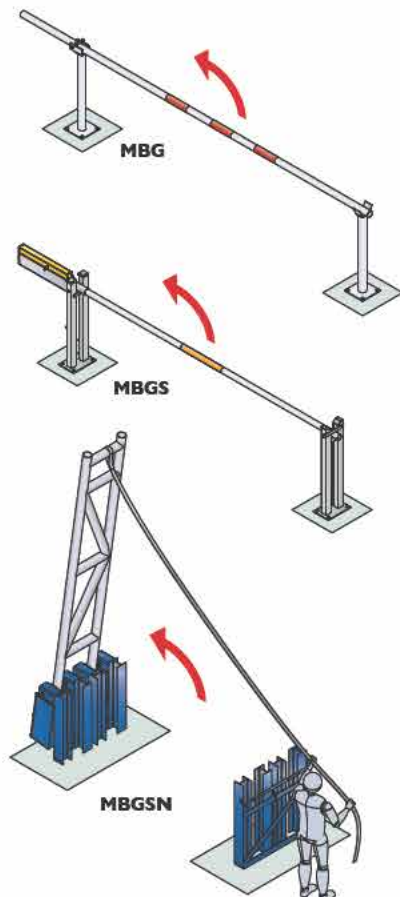

### Automatic Vertical Boom Gates

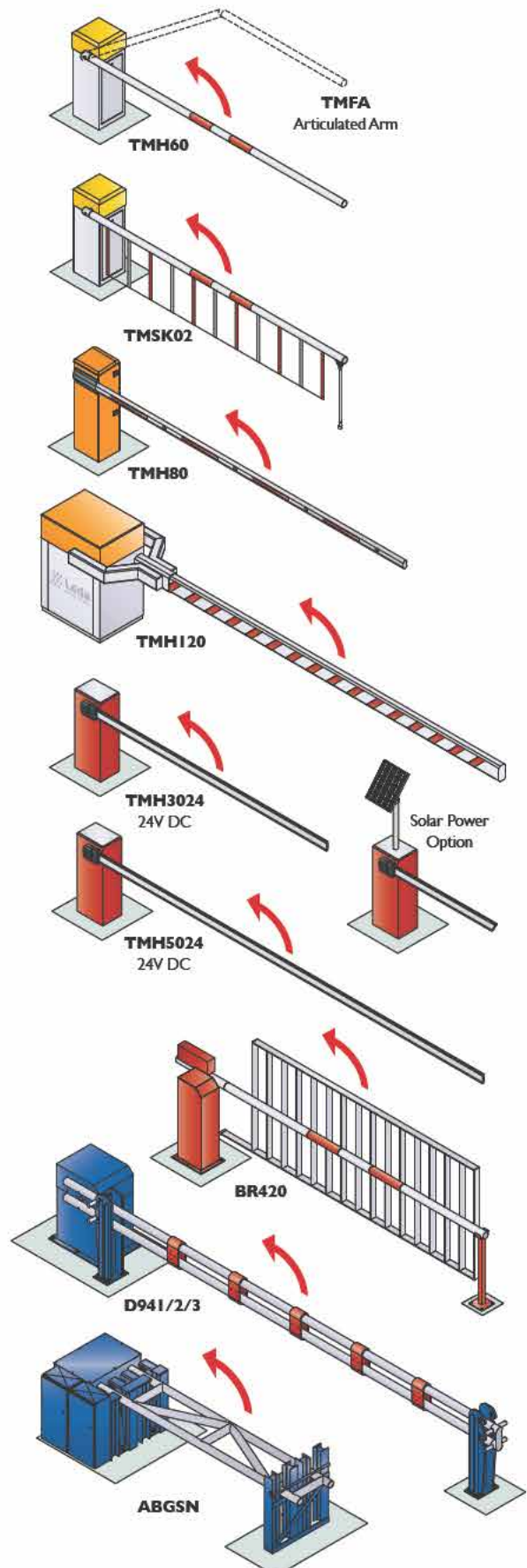

1300 780 450

Standard Configurations

Boom gates are normally installed to restrict unauthorised vehicle ingress or egress. Access entry and exit may be restricted to a single lane in which case it is possible to provide controlled exit or free exit.

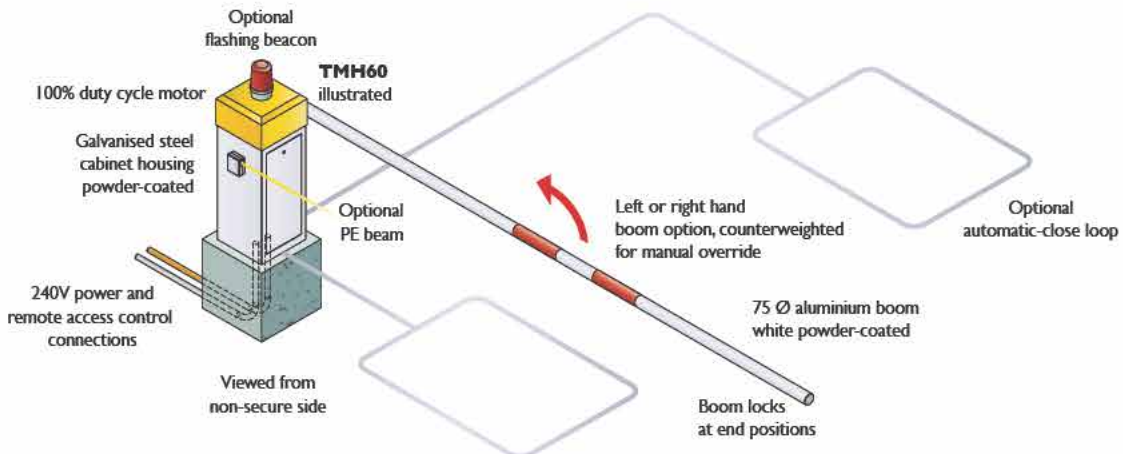
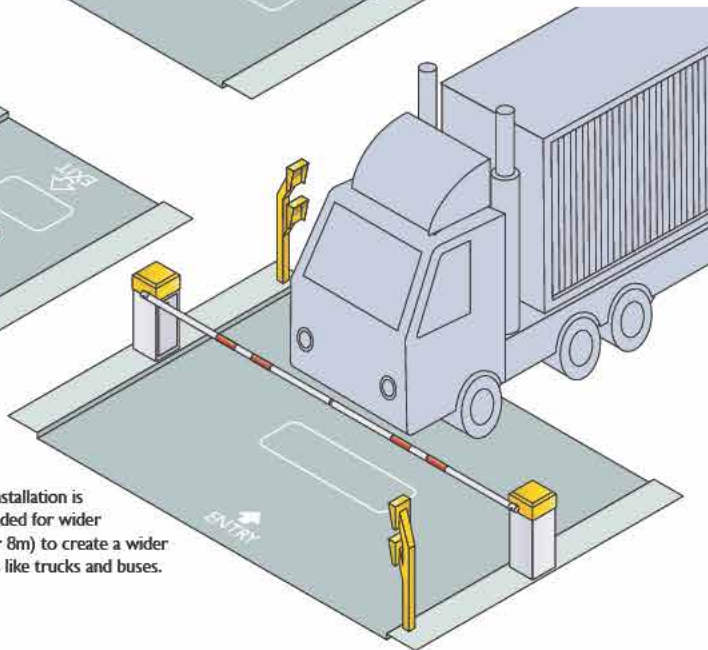
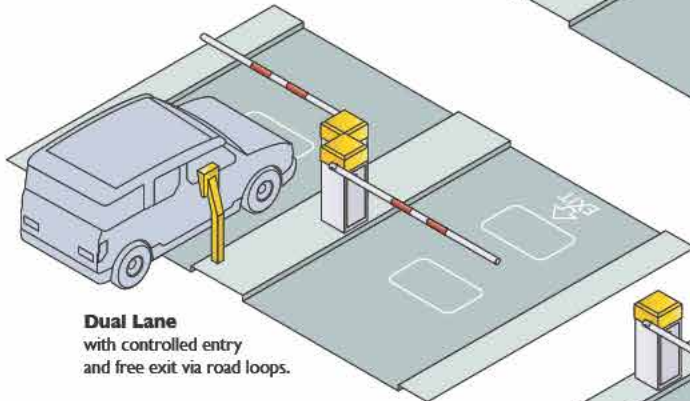
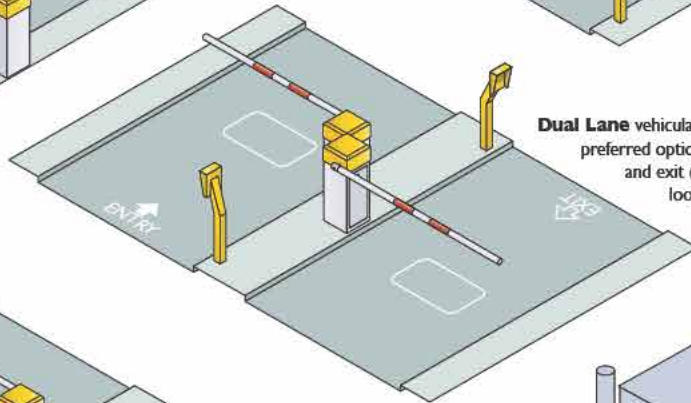
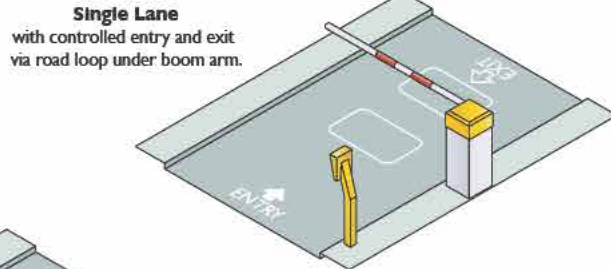
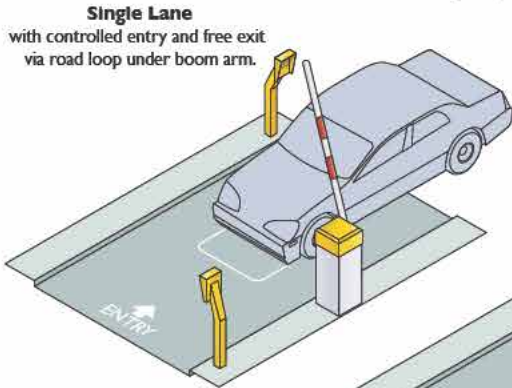

Intro	2
Gates	14
Track	20
Cantilever	30
Swing	40
Bi-fold	46
Boom	52
Options	76
General	82
Barriers	94
Blockers	100
Tyre Spikes	102
Pre-cast	106
Other	111
Pedestrian	114
Turnstiles	114
Gates & Doors	136
Fencing	142
Code Index	153

# Product Range > Gates > Vertical Boom

☎ 1300 780 450

## Industrial TM Series – Electric

### Fabrication

Boom Arm  
75 Ø Aluminium Pipe

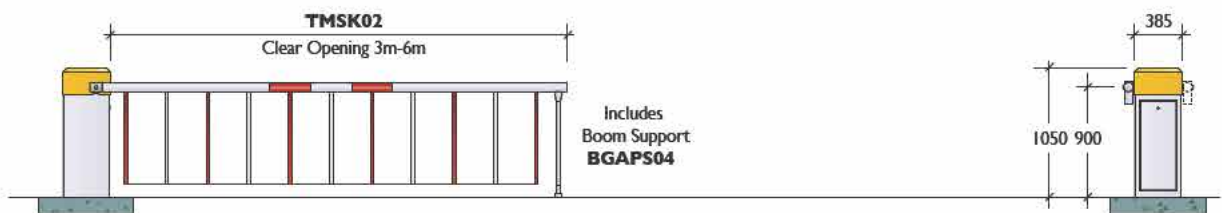
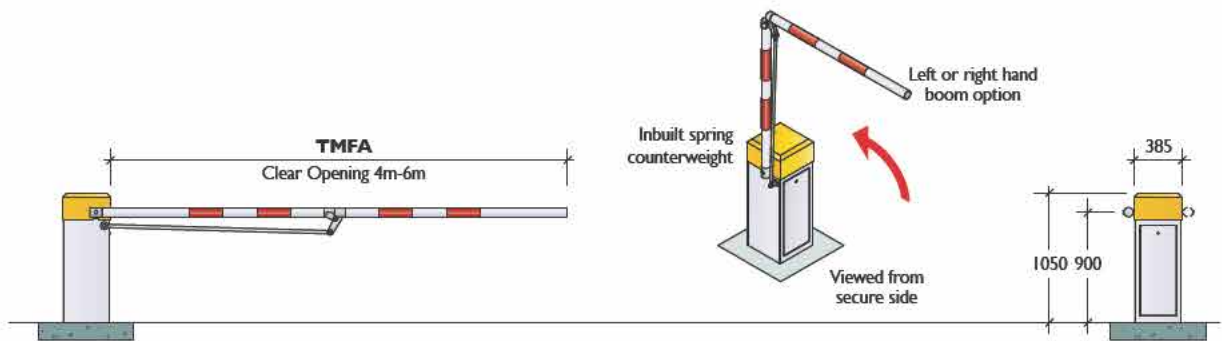
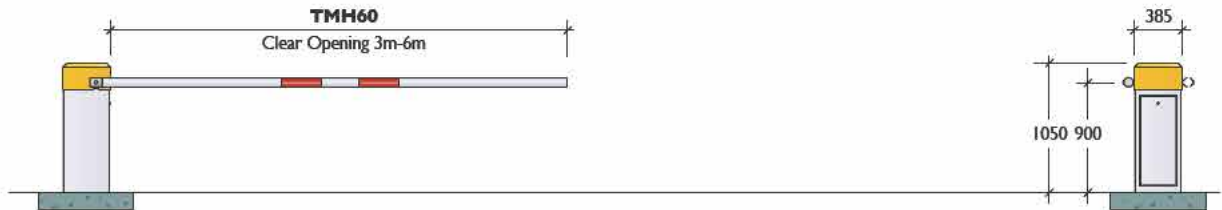
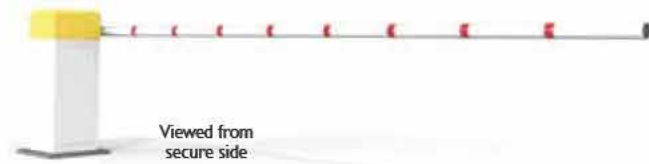

The TM Series of boom gates is the most popular and widely used in the range. A reliable 'workhorse', it is both economical to operate and easy to maintain.

### The Drive Unit

The majority of Leda's industrial boom gates are driven by a 100% duty cycle torque motor designed for alternating current which does not require limit switches nor a friction clutch. They are virtually maintenance-free and can be stalled in any position without causing any damage to the motor. The boom gates are factory-wired, tested, ready to connect and supplied with all necessary mounting accessories.

### Technical Data

Drive Unit	Torque Motor
Power / Rating	240V / 120W / 50Hz Frequency
Open / Close Speed	Average 4 seconds (approx 1 sec/m boom length)
Boom	Material $\phi 75 \times 1.6$ mm aluminium, white powdercoat
	Length Maximum 6000mm
Housing	Size 300 x 300 x 1000mm height
	Finish 2mm zinc plated sheet, powder coated
	Weight 45kg

Vertical Boom Industrial	Manual Override	Clear Opening Width Range	Height Range
<b>TMH60</b>	Inbuilt spring	3.0m-6.0m	0.9m
<b>TMFA</b>	Articulated Arm Inbuilt spring	4.0m-6.0m	0.9m
<b>TMSK02</b>	with Skirt External counterweight	7.0m-8.0m	0.9m

Stainless steel cabinets also available, add S prefix to Product Code. (eg. **STMH60**)



1300 780 450

**Industrial**  
**TH Series – Hydraulic**

**Fabrication**  
Elliptical Boom Arm  
Anodised Aluminium

- Options**
- Flashing beacon
  - Stainless steel cabinet
  - Safety beams
  - LED lighting on boom arm

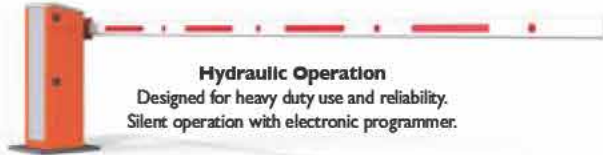

**Hydraulic Operation**  
Designed for heavy duty use and reliability.  
Silent operation with electronic programmer.

**TMH80**

Boom Arm Length (m)	Operating Time (sec)
4.2	4
6.4	8

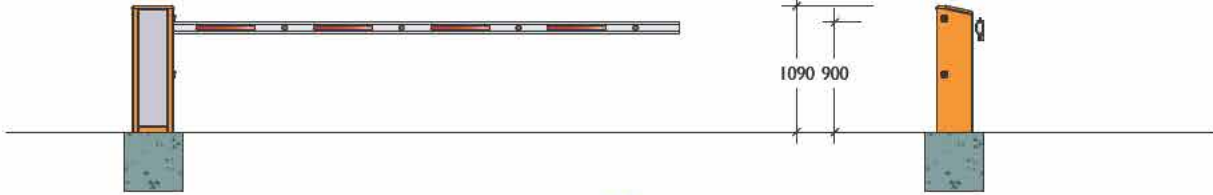

**TMH80S with Skirt**

Boom Arm Length (m)	Operating Time (sec)
4.2	14
6.4	19

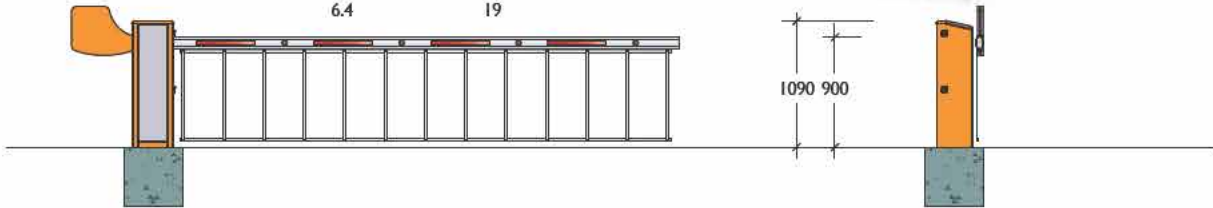

**TMH80CW with wire rope supports and counterweight**

Boom Arm Length (m)	Operating Time (sec)
7.0	19
8.0	19

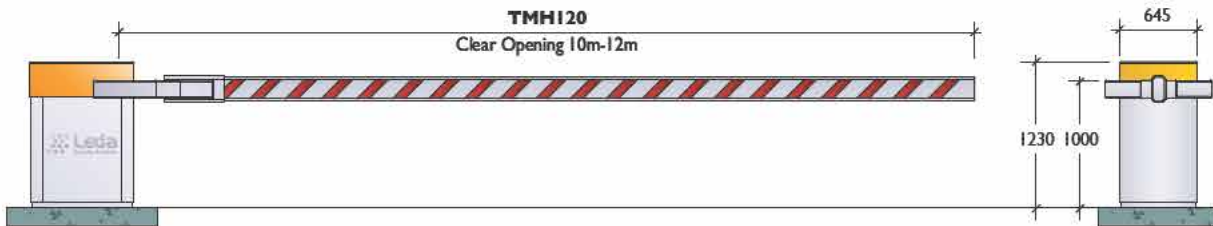
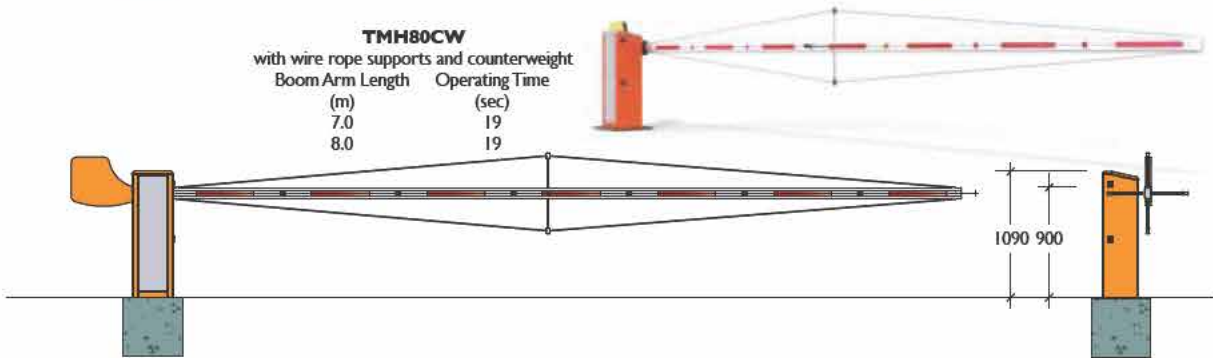

Intro	2
Gates	14
Track	20
Cantilever	30
Swing	40
Bi-fold	46
Boom	52
Options	76
General	82
<b>Barriers</b>	<b>94</b>
Blockers	100
Tyre Spikes	102
Pre-cast	106
Other	111
<b>Pedestrian</b>	<b>114</b>
Turnstiles	114
Gates & Doors	136
<b>Fencing</b>	<b>142</b>
<b>Code Index</b>	<b>153</b>

Vertical Boom Industrial	Manual Override	Clear Opening Width Range	Height Range
<b>TMH80</b>	External counterweight	4.2m or 6.4m	0.9m
<b>TMH80S</b> with skirt	External counterweight	4.2m or 6.4m	0.9m
<b>TMH80CW</b> wire rope supports & counterweight	External counterweight	7.0m-8.0m	0.9m
<b>TMH120</b>	Internal counterweight	10.0m-12.0m	1.0m

Stainless steel cabinets also available, add S prefix to Product Code. (eg. **STMH80**)

# Product Range > Gates > Vertical Boom

1300 780 450

## Industrial Low Voltage

Many industries, particularly the mining industry, prefer the low voltage models for OH&S requirements.

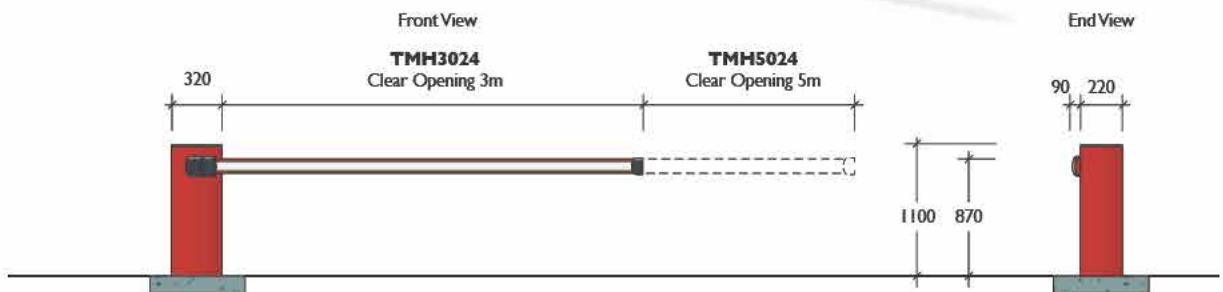

Vertical Boom Industrial Low Voltage	Width Range	Height Range
TMH3024 / 5024	3.0m / 5.0m only	0.87m

## Industrial Portable

Leda's Portable Boom Gate has been primarily developed for temporary locations such as building and mining sites.

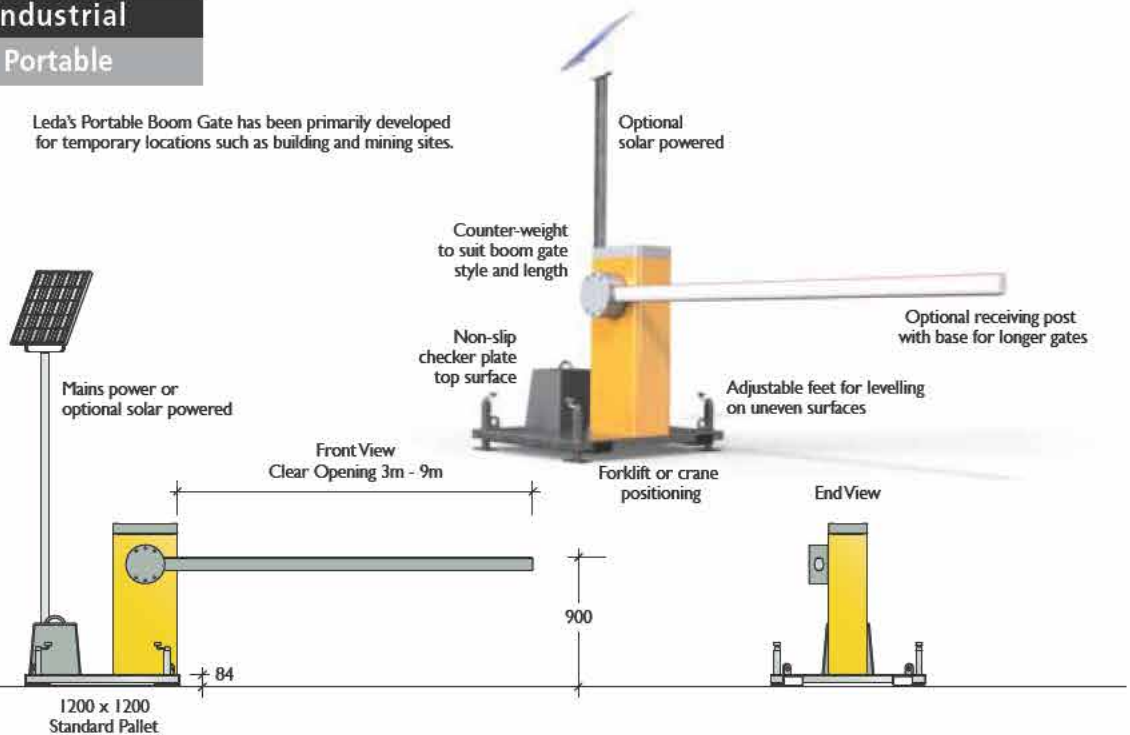

Vertical Boom Industrial Portable	Width Range	Height Range
TMHP39	3.0m - 9.0m	0.9m

Product Range > Gates > Vertical Boom

1300 780 450

**Industrial**  
**High Speed**

This robust and reliable boom gate is ideally suited for high-use applications and will cater for up to 10,000 operations a day.

**High Speed**  
**1.7 Second**  
**Opening**

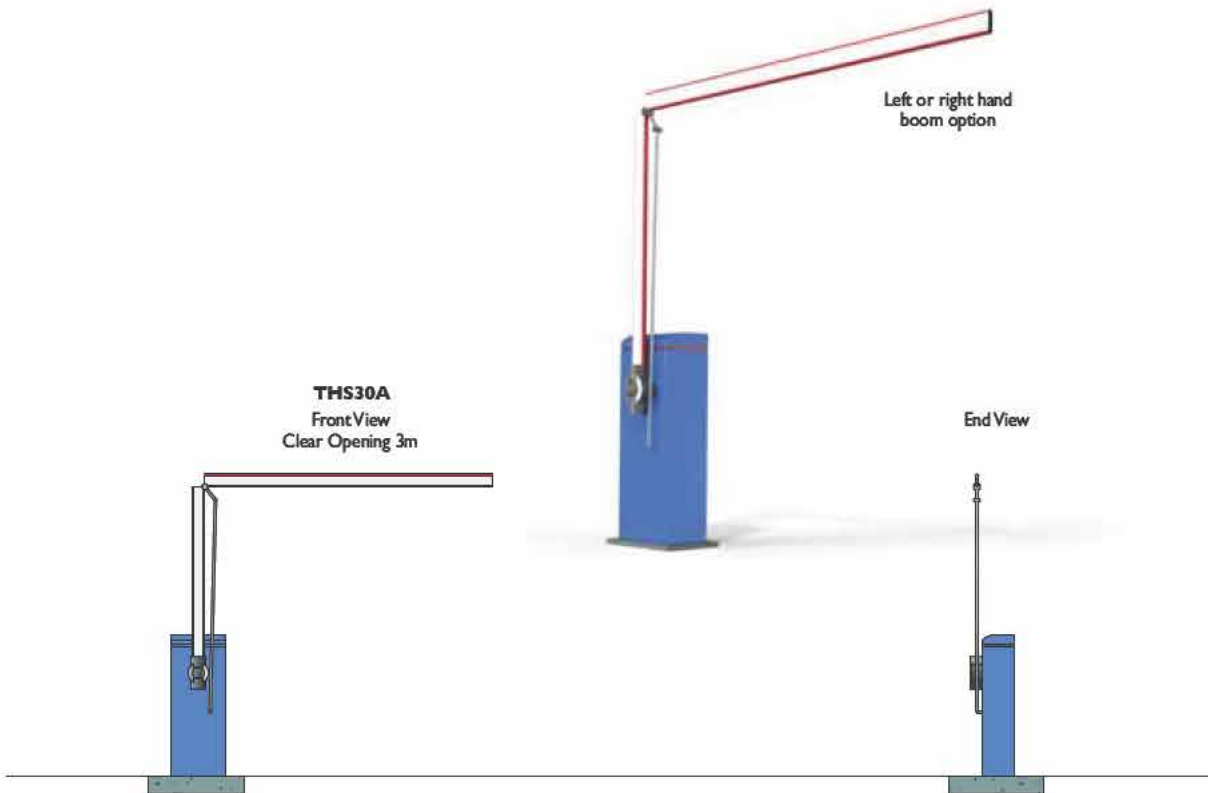
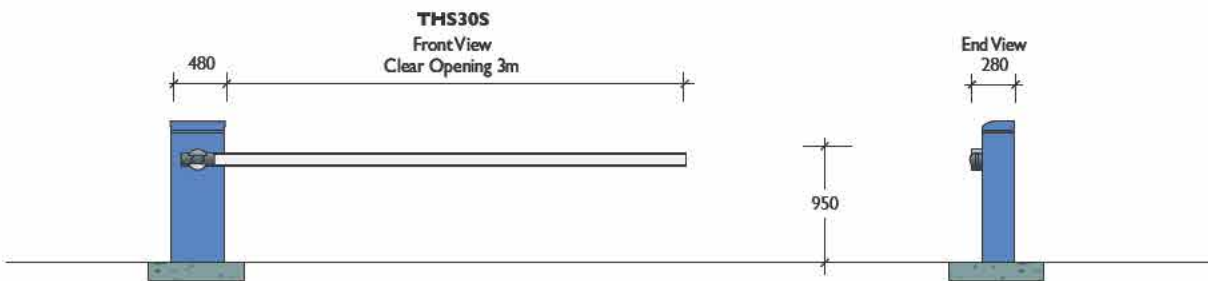
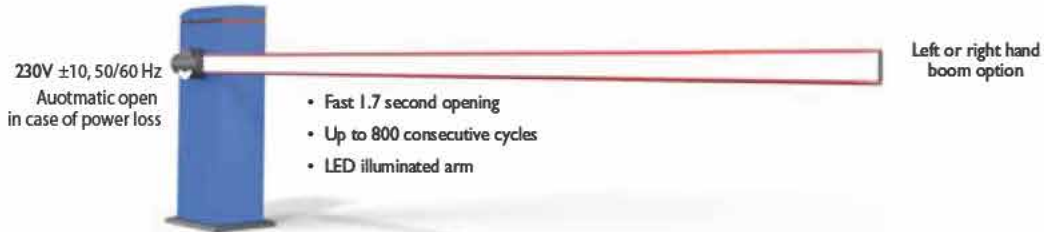

<b>Intro</b>	<b>2</b>
<b>Gates</b>	<b>14</b>
Track	20
Cantilever	30
Swing	40
Bi-fold	46
Boom	52
Options	76
General	82
<b>Barriers</b>	<b>94</b>
Blockers	100
Tyre Spikes	102
Pre-cast	106
Other	111
<b>Pedestrian</b>	<b>114</b>
Turnstiles	114
Gates & Doors	136
<b>Fencing</b>	<b>142</b>
<b>Code Index</b>	<b>153</b>

Vertical Boom Industrial High Speed	Details	Width Range	Height Range
<b>THS30S</b>	Standard Boom	3.0m only	0.95m
<b>THS30A</b>	Articulated Boom	3.0m only	0.95m



# Product Range > Gates > Vertical Boom

☎ 1300 780 450

## Options & Accessories

Note: These options may not be available for, or suit, certain models. Please check with your Leda sales office.

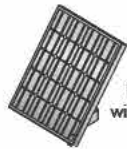

### Solar Power Kit

Photo voltaic Cell Panel with safety glass 10W x 24V (354h x 290w)



Control Box with 2 x 12V 7.2Ah batteries (318h x 119w x 219d)

Leda's Solar Power Kit is ideally suited for installation in on sites where mains power is not available, and will cater for up to 30 movements per day. It is an economical option and in many instances can save the considerable cost of mains power installation.

- Park entrances
- Mining sites
- Remote locations
- Industrial and commercial sites.

### Boom Skirts TMSK02

Designed to prevent pedestrian access. It is attached to the boom arm and pivots so uprights remain vertical when the boom is raised.

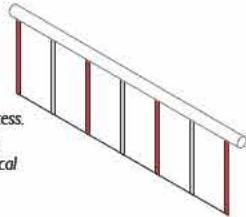

### PVC Boom Arm PVCBA3

Extendable boom arm – for high accident risk applications. Economical and quick to replace. Available in 3.0 metre lengths only.

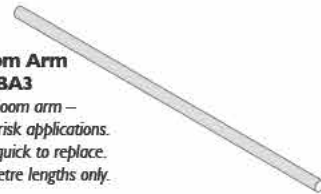

### Boom Support BGAPS04

Attached to the boom arm and pivots to remain vertical when the boom is raised.

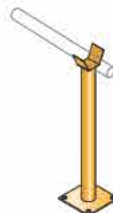

### Boom Stand BGABS

Fixed to the pavement – locking option available. Recommended for wider openings.



### Magnetic Lock DDMAG



### Stainless Steel Cabinet

Add 'S' prefix to Product Code eg. TMMH60S



### Cabinet Cladding

When aesthetics are important, cabinets can be clad in timber or stone

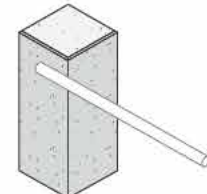

### Flashing Beacon FLA001

### Safety Beam PEBEAM

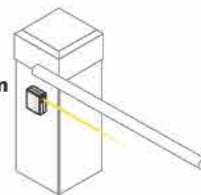

### Safety Beam Extension PEBEAMX

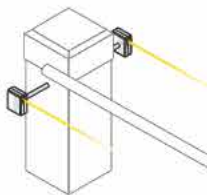

### PVC Canvas Signage

Tailored to your requirements



### Stop Sign STOP



### LED Lights THLED

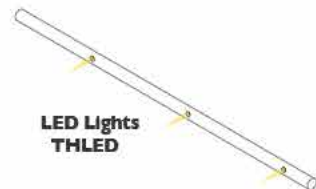

### Card Readers

A range of models that can accommodate the majority of access control devices, CCTV and intercom requirements.

For the complete range, refer to [www.ledasecurity.com.au](http://www.ledasecurity.com.au) or the Leda Security Bollard Handbook.

1300 780 450



<b>Intro</b>	<b>2</b>
<b>Gates</b>	<b>14</b>
Track	20
Cantilever	30
Swing	40
Bi-fold	46
Boom	52
Options	76
General	82
<b>Barriers</b>	<b>94</b>
Blockers	100
Tyre Spikes	102
Pre-cast	106
Other	111
<b>Pedestrian</b>	<b>114</b>
Turnstiles	114
Gates & Doors	136
<b>Fencing</b>	<b>142</b>
<b>Code Index</b>	<b>153</b>

# Product Range > Gates > Vertical Boom

☎ 1300 780 450

## Security BR410 Series

- Reliable electro-hydraulic operation for years of trouble-free service
- Continuous operation rated – no limit to number of operations per hour
- Smooth controlled operation (4-6 seconds)
- Counter-balanced arm
- Vandal-resistant cabinet if installed in unsupervised locations
- Optional protective shroud (BSHSHROUD)



10mm / 3mm MS steel  
continuously welded cabinet



Viewed from  
secure side

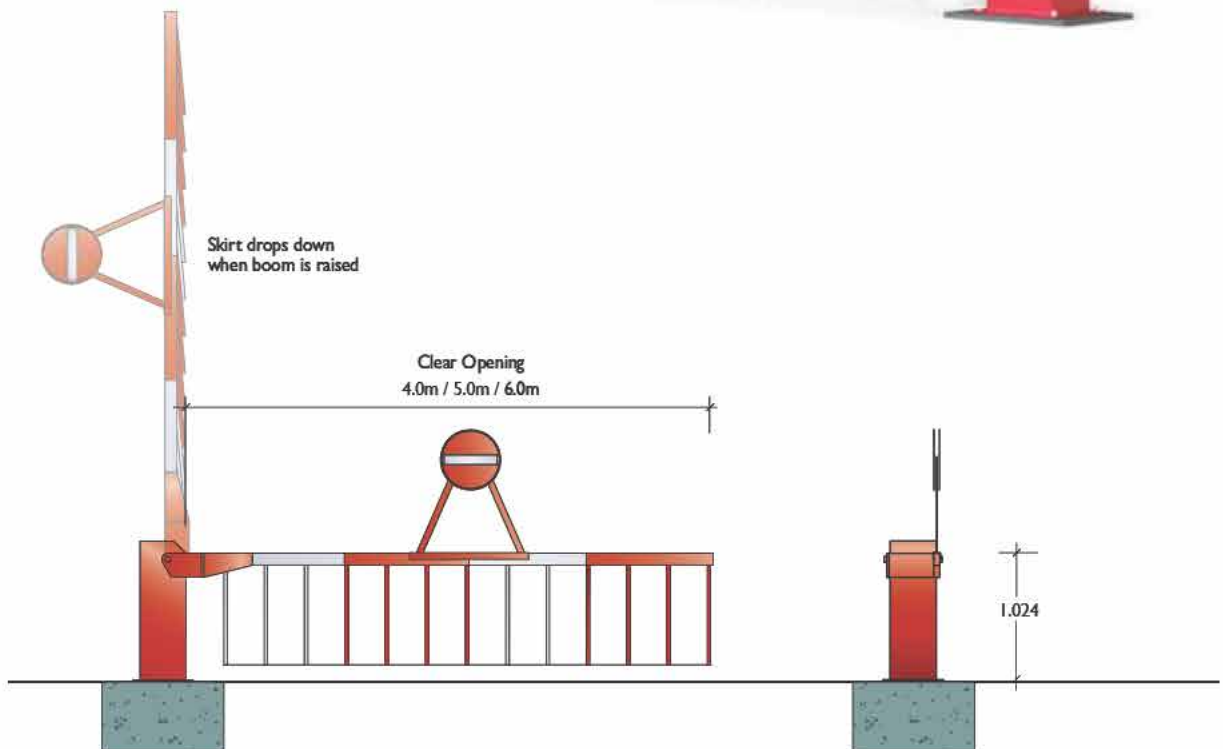

Vertical Boom Security	Width Range	Height Range
BR4104	4.0m	1.024m
BR4105	5.0m	1.024m
BR4106	6.0m	1.024m



☎ 1300 780 450

**Security**

**BR420 Series**

- Reliable electro-hydraulic operation for years of trouble-free service
- Continuous operation rated – no limit to number of operations per hour
- Smooth controlled operation (4-6 seconds)
- Counter-balanced arm
- Vandal-resistant cabinet if installed in unsupervised locations
- Optional protective shroud (BSHSHROUD)

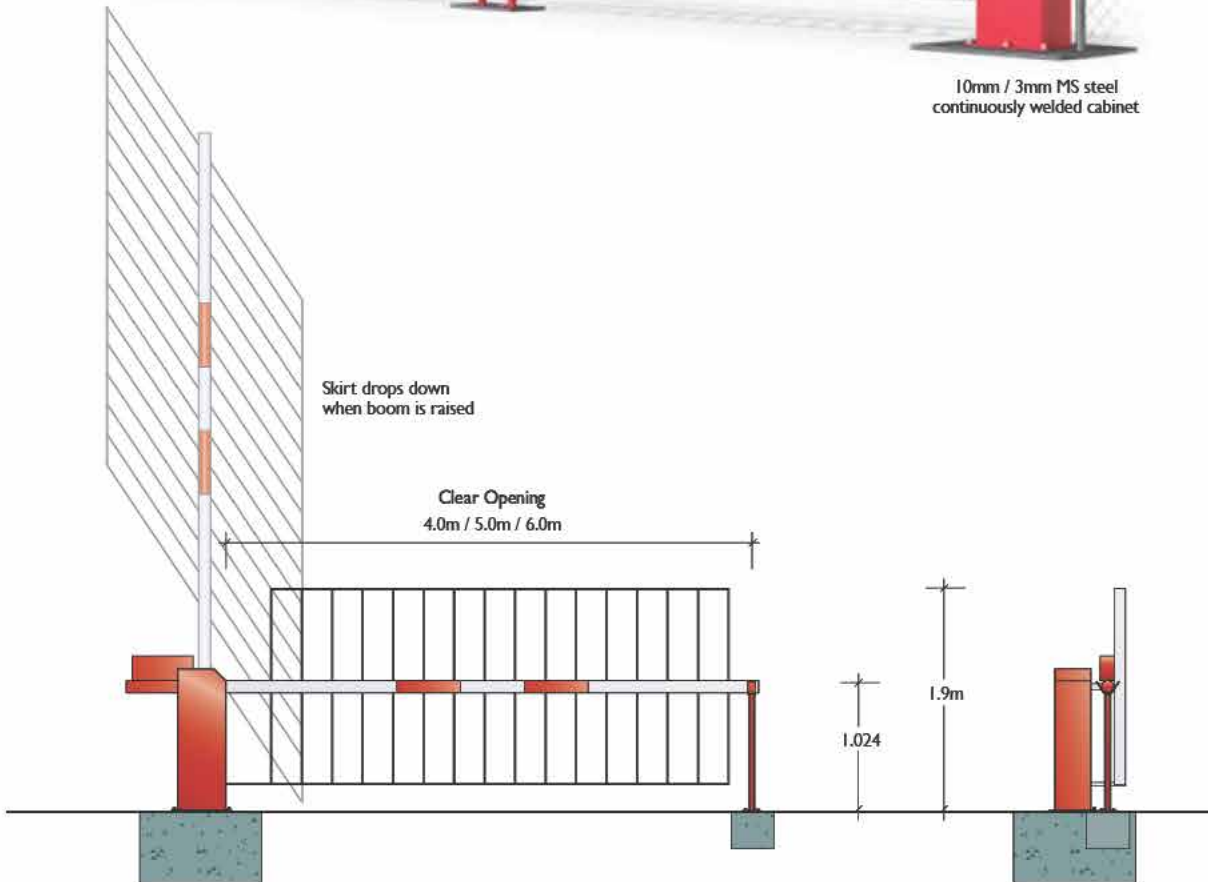
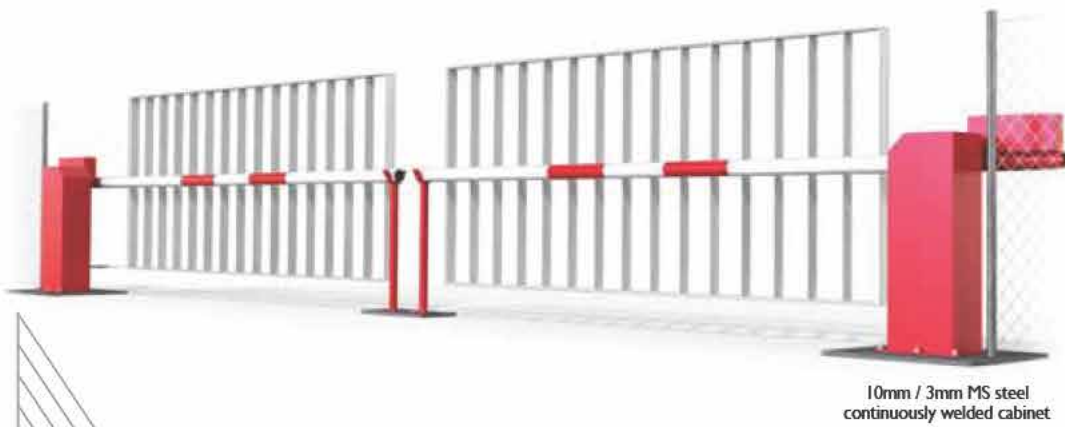
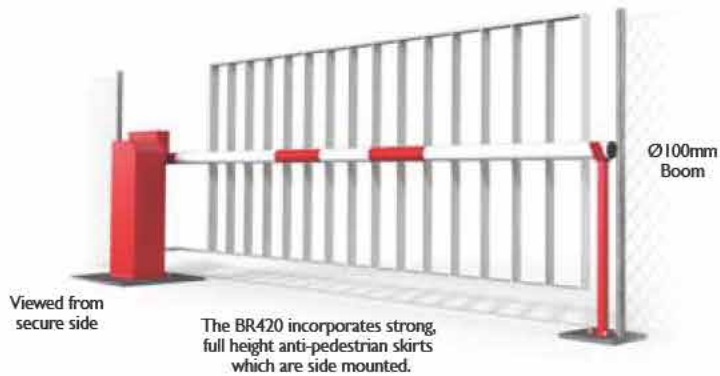

<b>Intro</b>	<b>2</b>
<b>Gates</b>	<b>14</b>
Track	20
Cantilever	30
Swing	40
Bi-fold	46
Boom	52
Options	76
General	82
<b>Barriers</b>	<b>94</b>
Blockers	100
Tyre Spikes	102
Pre-cast	106
Other	111
<b>Pedestrian</b>	<b>114</b>
Turnstiles	114
Gates & Doors	136
<b>Fencing</b>	<b>142</b>
<b>Code Index</b>	<b>153</b>

<b>Vertical Boom Security</b>	<b>Width Range</b>	<b>Height Range</b>
<b>BR4204</b>	4.0m	1.9m
<b>BR4205</b>	5.0m	1.9m
<b>BR4206</b>	6.0m	1.9m

## Product Range > Gates > Vertical Boom

☎ 1300 780 450

Leda is the Australian Distributor for Broughton Controls who are one of the world's leading suppliers of high security boom gates.

The Defender series features world-leading fibre strap technology that is incorporated into the boom arms to provide high security vehicular access control barriers.

To maintain security levels after an impact, the unique 'composite Cassette' system is designed to allow replacement of the beam within 20 minutes.

There are 3 models, each tested and certified to provide different levels of security.

- D941 3.5 tonne @ 48km/h
- D942 7.5 tonne @ 48km/h
- D943 7.5 tonne @ 64km/h

At time of publication, Broughton Controls has designed an additional barrier with a higher level of security. The D944 has been engineered to withstand a 7.5 tonne vehicle travelling at 80km/h, and is scheduled for testing in 2013.

Utilising shallow depth footing designs (500mm), the steel stanchions capture and distribute the impact loads, demonstrated by the successful field testing that has led to PAS68 certification.



**// This is simply the most cost-effective automated PAS68 tested equipment available in Australia. //**  
Heng Cheng  
High Security Advisor and Consultant

Leda has successfully installed numerous Defender barriers across Australia on high security government and commercial sites.



Apart from being PAS68 certified, they provide a much more economic alternative to many other high security barrier options as more and more consultants and clients are finding.



As with all high security equipment installations, correct anchoring of the barriers is critical. The engineering supporting the necessary concrete footings is highly confidential and will only be provided once a contract has been entered into to supply, or supply and install Leda's equipment.

### High Security Defender Series

#### Fabrication

Boom Arm  
Fibre strap and  
'Composite Cassette'  
inside the aluminium arms



- 'BIT' vehicle restraint technology
- Heavy duty hydraulic operation
- Operating speed 5-18 seconds, depending upon boom length
- 100% duty cycle
- IP65 rated control housing

Suitable for high volume traffic situations to protect high risk sites where vehicle impact is a real threat

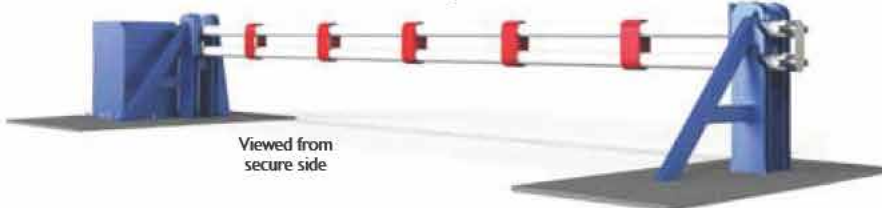

Viewed from secure side

500mm deep shallow mount footing system to allow simple, low cost, ease of installation. Engineered footing details will be provided by Leda before installation.

Vertical Boom High Security	Width Range	Height
D941	3.0m-6.0m	0.925m
D942	3.0m-6.0m	0.925m
D943	3.0m-6.0m	0.925m

☎ 1300 780 450

D941

**PAS68 TESTED**

**Tested and Certified**  
(3.5 tonne @ 48km/h)  
V3500 (N2) 48/90 : 0.5/0.0



D942

**PAS68 TESTED**

**Tested and Certified**  
(7.5 tonne @ 48km/h)  
V7500 (N2) 48/90 : 0.0/7.9



D943

**PAS68 TESTED**

**Tested and Certified**  
(7.5 tonne @ 64km/h)  
V7500 (N2) 64/90



**High Security  
Defender Series**

<b>Intro</b>	<b>2</b>
<b>Gates</b>	<b>14</b>
Track	20
Cantilever	30
Swing	40
Bi-fold	46
Boom	52
Options	76
General	82
<b>Barriers</b>	<b>94</b>
Blockers	100
Tyre Spikes	102
Pre-cast	106
Other	111
<b>Pedestrian</b>	<b>114</b>
Turnstiles	114
Gates & Doors	136
<b>Fencing</b>	<b>142</b>
<b>Code Index</b>	<b>153</b>

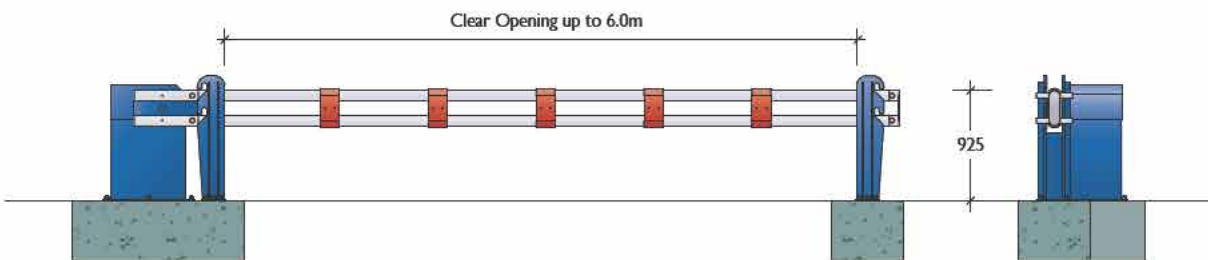

At time of publication, Broughton Controls has designed an additional barrier with a higher level of security. The D944 has been engineered to withstand a 7.5 tonne vehicle travelling at 80km/h, and is scheduled for testing in 2013.



# Product Range > Gates > Vertical Boom

☎ 1300 780 450

## High Security

### Manual

#### Fabrication

Boom Arm  
100 Ø Mild Steel HD Pipe



**PAS68  
TESTED**

Both manual and automatic models  
have been installed on  
numerous government sites across Australia.

Counter-weighted  
so arm remains  
in open position  
until manually closed

Viewed from  
secure side

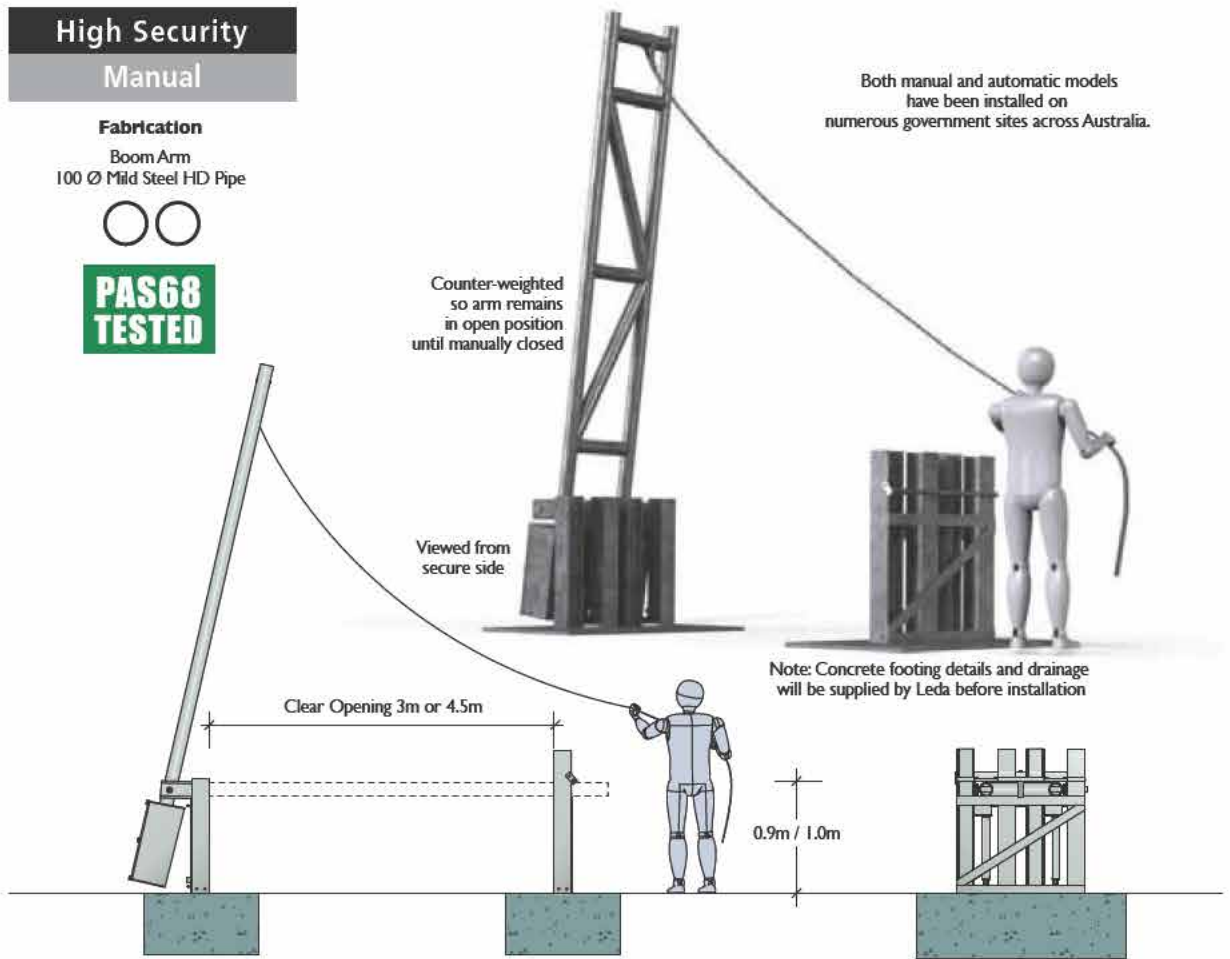

## High Security

### Automatic

#### Fabrication

Boom Arm  
100 Ø Mild Steel HD Pipe



**PAS68  
TESTED**

Hydraulically-powered  
adjustable opening and  
closing speeds

Viewed from  
secure side

Note: Concrete footing details and drainage  
will be supplied by Leda before installation

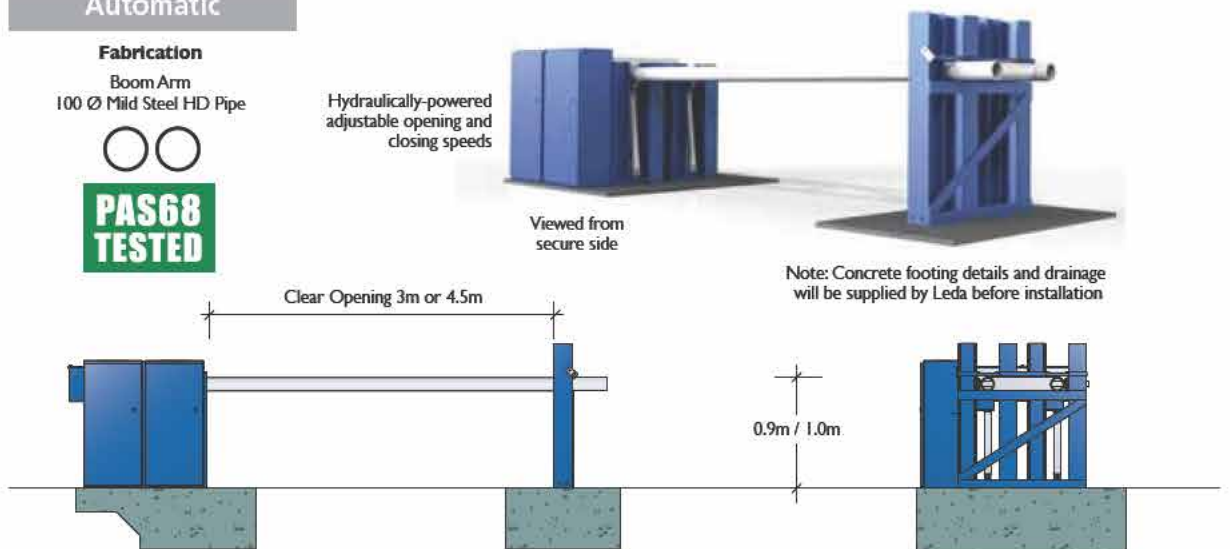

Vertical Boom High Security		Impact Rating	Width Range	Height Range
<b>Manual</b>	<b>MNB33580</b>	3500kg@80km/h	3.0m	0.9m / 1.0m
	<b>MNB37548</b>	7500kg@48km/h	3.0m	0.9m / 1.0m
	<b>MNB47548</b>	7500kg@48km/h	4.5m	0.9m / 1.0m
<b>Automatic</b>	<b>ANB33580</b>	3500kg@80km/h	3.0m	0.9m / 1.0m
	<b>ANB37548</b>	7500kg@48km/h	3.0m	0.9m / 1.0m
	<b>ANB47548</b>	7500kg@48km/h	4.5m	0.9m / 1.0m

Product Range > Gates > Vertical Boom

1300 780 450

Advantage

Manual

Fabrication

Boom Arm  
80 Ø Aluminium Tube



Baseplate & Fixed Insitu  
Models

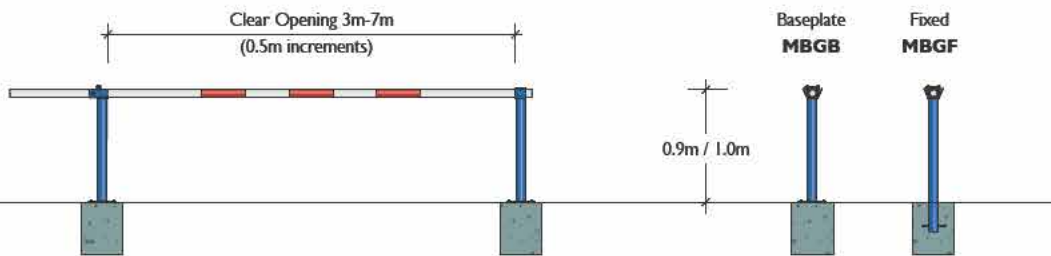
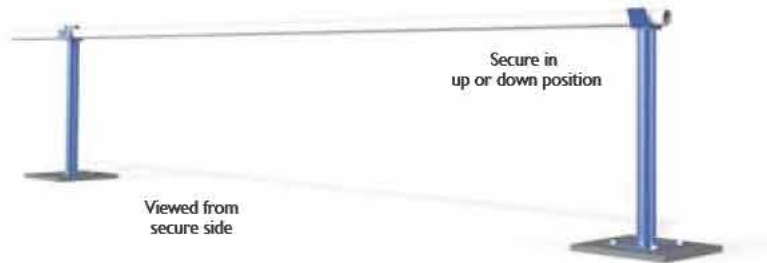

Vertical Boom Advantage	Width Range	Height Range
MBGB / MBGF	3.0m-7.0m (0.5m increments †)	0.9m / 1.0m

† Increments available within width range.

Security

Manual

Fabrication

Boom Arm  
80 Ø Mild Steel Pipe



Baseplate & Fixed Insitu  
Models

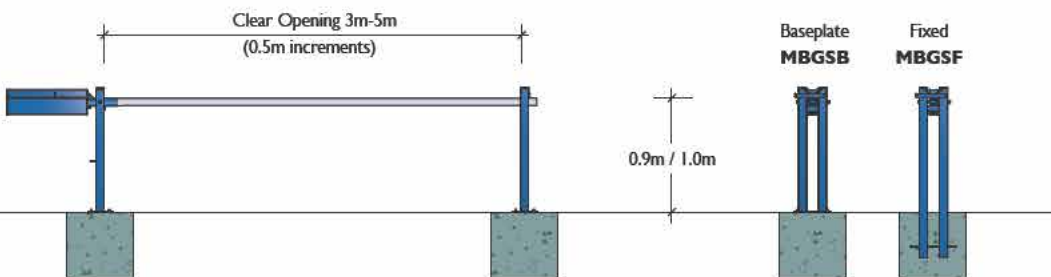
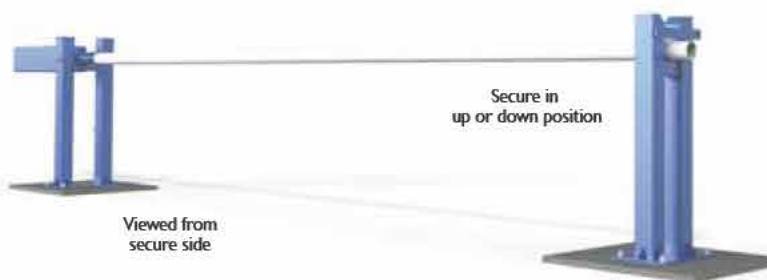

Vertical Boom Security	Width Range	Height Range
MBGSB / MBGSF	3.0m-5.0m (0.5m increments †)	0.9m / 1.0m

† Increments available within width range.

Intro	2
Gates	14
Track	20
Cantilever	30
Swing	40
Bi-fold	46
Boom	52
Options	76
General	82
Barriers	94
Blockers	100
Tyre Spikes	102
Pre-cast	106
Other	111
Pedestrian	114
Turnstiles	114
Gates & Doors	136
Fencing	142
Code Index	153

# Product Range > Gates > Swing Boom

1300 780 450

## Advantage

### Fabrication

Boom Frame  
75 x 50 RHS



### Finish

Galvanised or  
powder coated in  
a range of colours

Manual swing gates are an economical option for sealing a vehicle area's control point. They are normally padlock-secured to a bollard in the closed position. As this is an option, please specify at time of ordering.

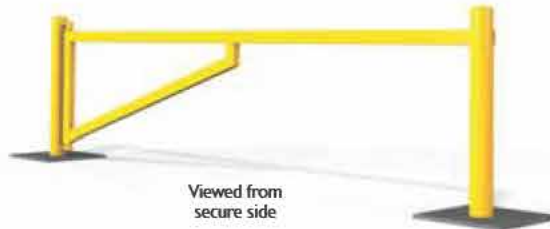
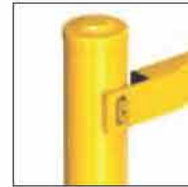

Viewed from  
secure side

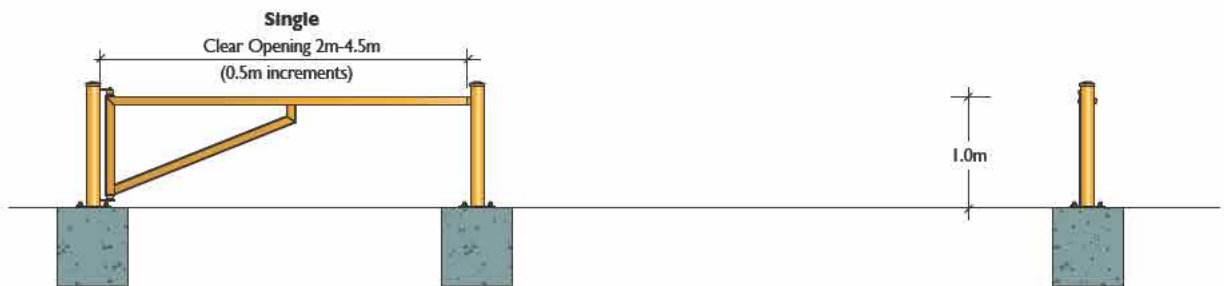

Padlock-secured to a bollard  
in the closed position.



Viewed from  
secure side

Optional  
locking & removable  
bollard

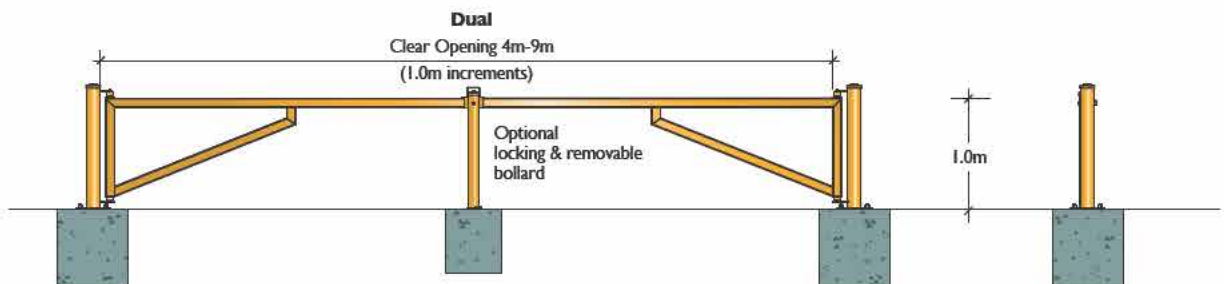

Optional  
locking & removable  
bollard

Swinging Boom Advantage		Width Range	Height Range
<b>MSG</b>	<b>Single</b>	2.0m-4.5m (0.5m increments †)	1.0m
<b>DSG</b>	<b>Dual</b>	4.0m-9.0m (1.0m increments †)	1.0m

† Increments available within width range.



Product Range > Gates > Swing Boom

☎ 1300 780 450

**Industrial**

**Fabrication**  
 Boom Frame  
 40Ø Mild Steel Pipe

○

**Finish**  
 Galvanised or powder coated in a range of colours

A marginally heavier and more robust model, they are normally padlock-secured to a bollard in the closed position. As this is an option, please specify at time of ordering.

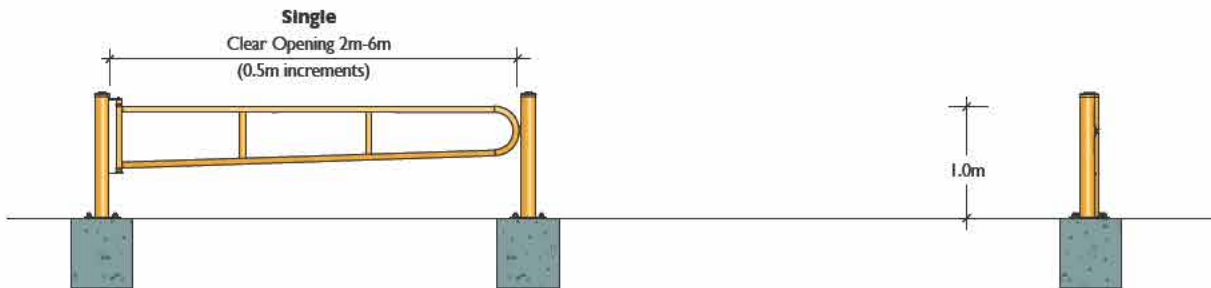
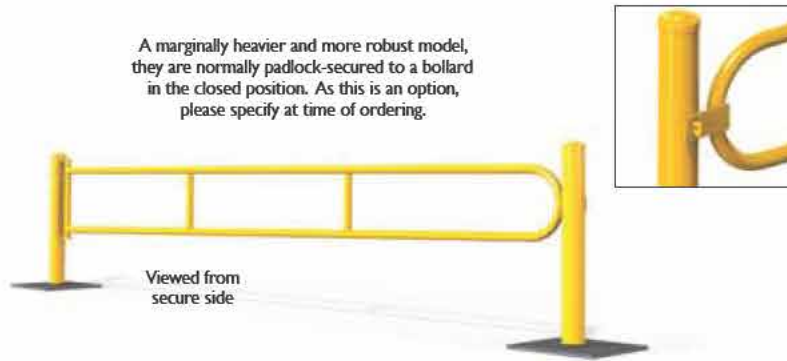

Padlock-secured to a bollard in the closed position.

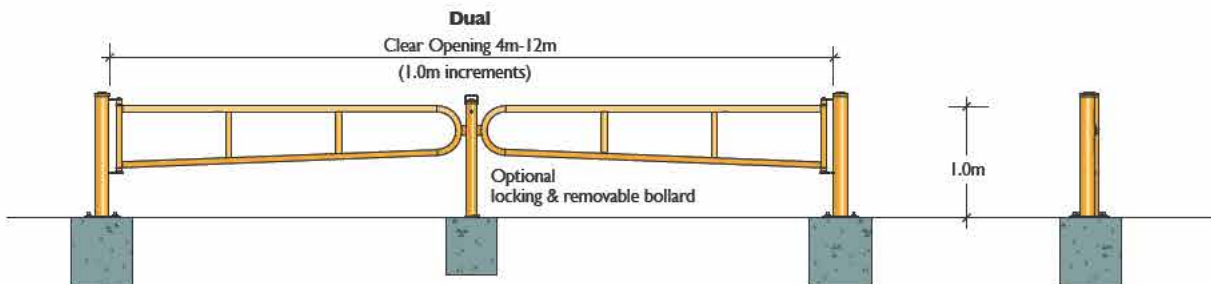
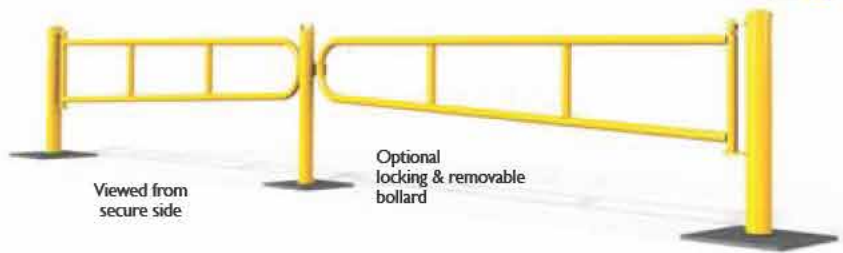

Intro	2
Gates	14
Track	20
Cantilever	30
Swing	40
Bi-fold	46
Boom	52
Options	76
General	82
<b>Barriers</b>	<b>94</b>
Blockers	100
Tyre Spikes	102
Pre-cast	106
Other	111
<b>Pedestrian</b>	<b>114</b>
Turnstiles	114
Gates & Doors	136
<b>Fencing</b>	<b>142</b>
<b>Code Index</b>	<b>153</b>

Swinging Boom Industrial		Width Range	Height Range
IMSG	Single	2.0m-6.0m (0.5m increments †)	1.0m
IDSG	Dual	4.0m-12.0m (1.0m increments †)	1.0m

† Increments available within width range.

# Product Range > Gates > Swing Boom

1300 780 450

## Security

### Finish

Hot dipped galvanised.  
Powder coated  
in a range of colours

### Fabrication

Boom Rail  
125 x 75 x 4 RHS



Bottom Rail  
100 x 75 x 4 RHS



Webbing  
75 x 75 x 3 SHS



A heavy duty manual boom gate for wide-opening security applications.

These drawings are reproduced courtesy of the Roads and Maritime Services of NSW and product is manufactured to their specifications

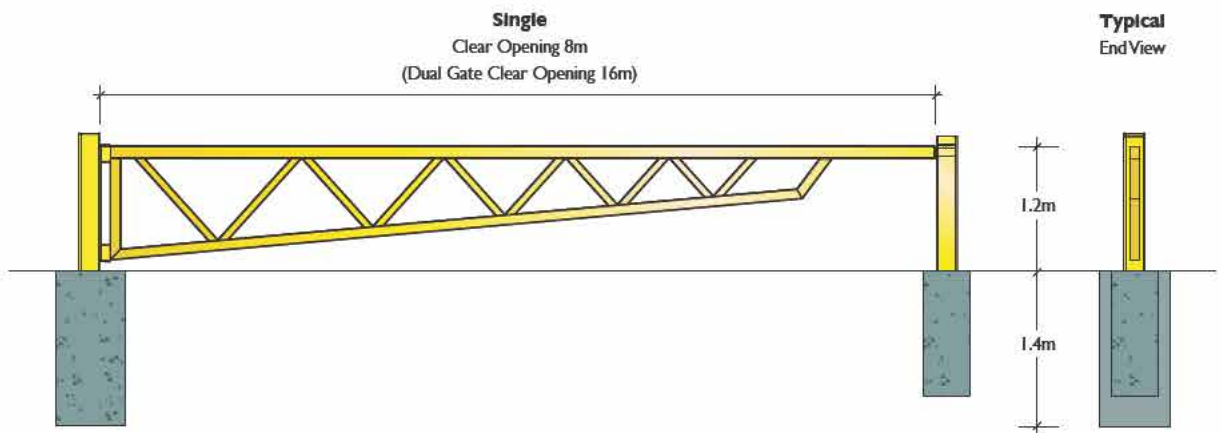

Swinging Boom Security	Width Range	Height Range
<b>SK010S Single</b>	8.0m	1.2m
<b>SK010D Dual</b>	16.0m	1.2m

1300 780 450

**Security**  
Cityscape Gate

- Synthetic fibre technology
- Impact rated: 7.5 tonne @ 64km/h
- Shallow footing engineering
- 4.0m to 6.0m widths
- Manual or automatic operation
- Aesthetically attractive

**PAS68  
TESTED**

**Tested and Certified**  
(7.5 tonne @ 64km/h)  
V7500 (N2) 64/90 : 1.09/2.4

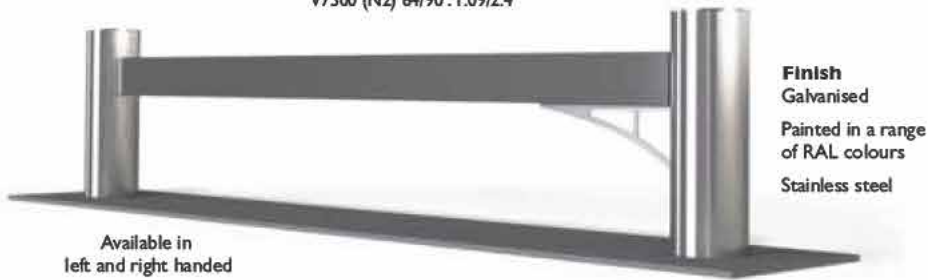

**Finish**  
Galvanised  
Painted in a range  
of RAL colours  
Stainless steel

Available in  
left and right handed

The Cityscape Gate is at the forefront of high security impact resistant technology, employing energy-absorbing synthetic fibre to arrest a wayward vehicle, and is ideal for sites with low or restricted vehicle movements. It is available in stainless steel, hot dipped galvanised or painted in a range of RAL colours, and is an aesthetically attractive solution in providing a tested and rated vehicle barrier.

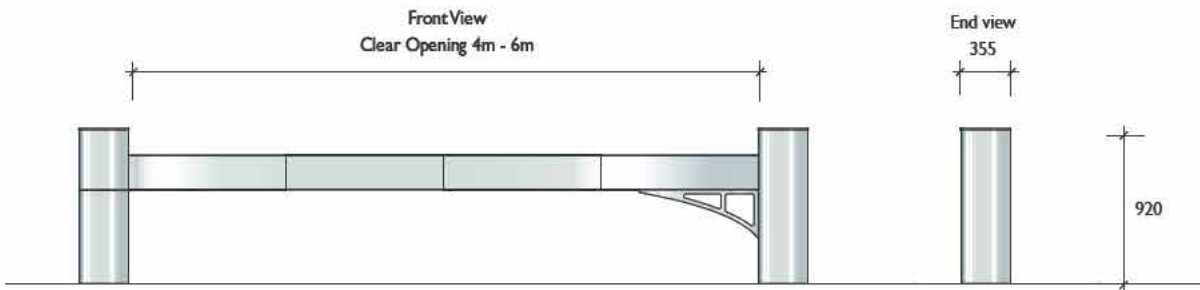

<b>Intro</b>	<b>2</b>
<b>Gates</b>	<b>14</b>
Track	20
Cantilever	30
Swing	40
Bi-fold	46
Boom	52
Options	76
General	82
<b>Barriers</b>	<b>94</b>
Blockers	100
Tyre Spikes	102
Pre-cast	106
Other	111
<b>Pedestrian</b>	<b>114</b>
Turnstiles	114
Gates & Doors	136
<b>Fencing</b>	<b>142</b>
<b>Code Index</b>	<b>153</b>

<b>Swinging Boom Security – Cityscape</b>		Width Range	Height Range
<b>CSG</b>	<b>Single Gate</b>	4.0m - 6.0m	920mm
		+1.0m increments	



## Product Range > Gates > Sliding Boom

☎ 1300 780 450



Sliding boom gates are designed and engineered to provide greater security and resistance to vandalism than conventional boom gate designs.

Originally designed for national parks and reserves, they prevent unauthorised vehicular access, yet allow pedestrians, hikers and fauna to transit.

Leda's engineers have designed several different models providing varying levels of security. Their ability to cater for wide openings has seen them used in a growing range of applications such as busways, parks and high security government sites.



☎ 1300 780 450

**Industrial**

**Fabrication**

Boom Arm  
125 x 75 RHS

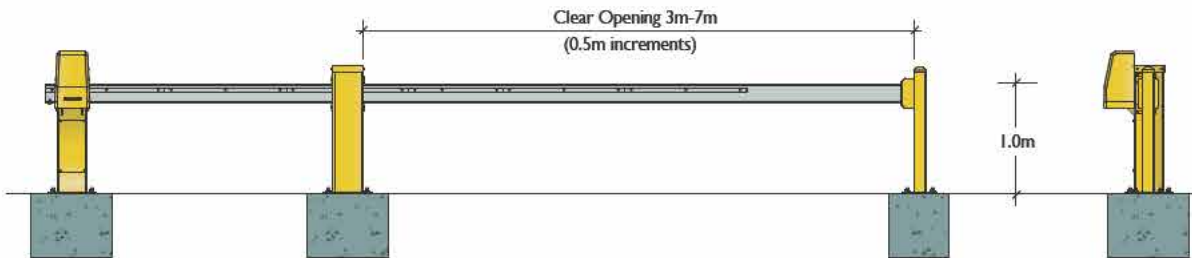

<b>Sliding Boom Industrial</b>	Width Range	Height Range
<b>ITSMBA</b>	3.0m-7.0m (0.5m increments †)	1.0m

† Increments available within width range.

**Security**

**Fabrication**

Boom Arm  
150 x 100 RHS  
200 x 100 RHS  
(dependent upon span)

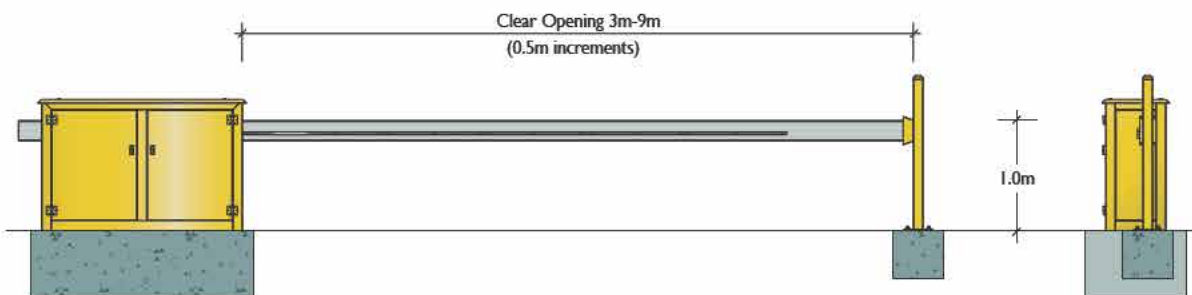
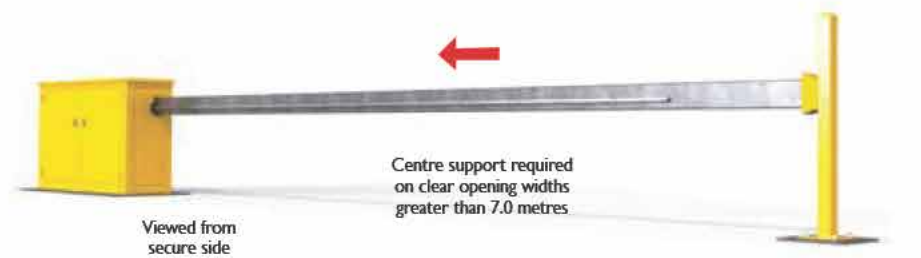

<b>Sliding Boom Security</b>	Width Range	Height Range
<b>TSMBA</b>	3.0m-9.0m (0.5m increments †)	1.0m

† Increments available within width range.

<b>Intro</b>	<b>2</b>
<b>Gates</b>	<b>14</b>
Track	20
Cantilever	30
Swing	40
Bi-fold	46
Boom	52
Options	76
General	82
<b>Barriers</b>	<b>94</b>
Blockers	100
Tyre Spikes	102
Pre-cast	106
Other	111
<b>Pedestrian</b>	<b>114</b>
Turnstiles	114
Gates & Doors	136
<b>Fencing</b>	<b>142</b>
<b>Code Index</b>	<b>153</b>

Product Range > Gates > Sliding Boom

1300 780 450

High Security

Fabrication

Boom Arm  
150 x 100 RH-S  
200 x 100 RH-S  
(dependent upon span)



Viewed from secure side

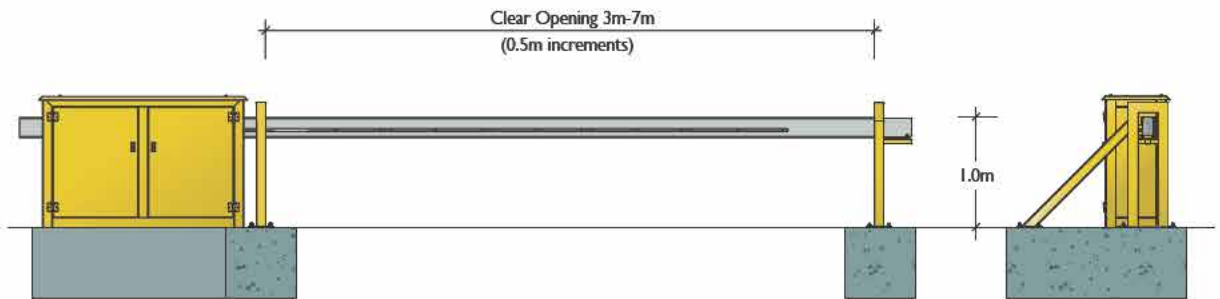

<b>Sliding Boom High Security</b>	Width Range	Height Range
<b>TSMBAH</b>	3.0m-9.0m (0.5m increments †)	1.0m

† Increments available within width range.

High Security

Fabrication

Boom Arm  
500 x 150



Viewed from secure side

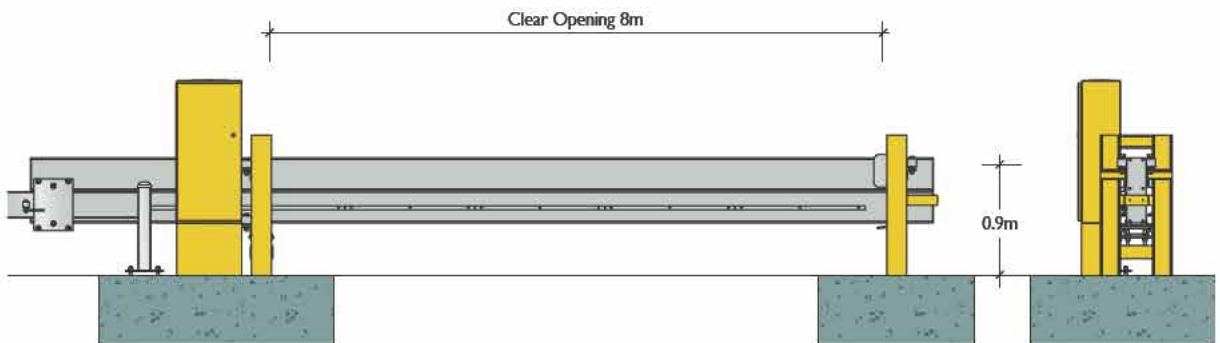

<b>Sliding Boom High Security</b>	Width Range	Height Range
<b>TSMBAXH</b>	8.0m	0.9m

† Increments available within width range.



1300 780 450

Boom Shrouds

Fabrication

Galvanised Mild Steel  
ITSMBA BS  
210 x 260



TSMBA BS  
220 x 350

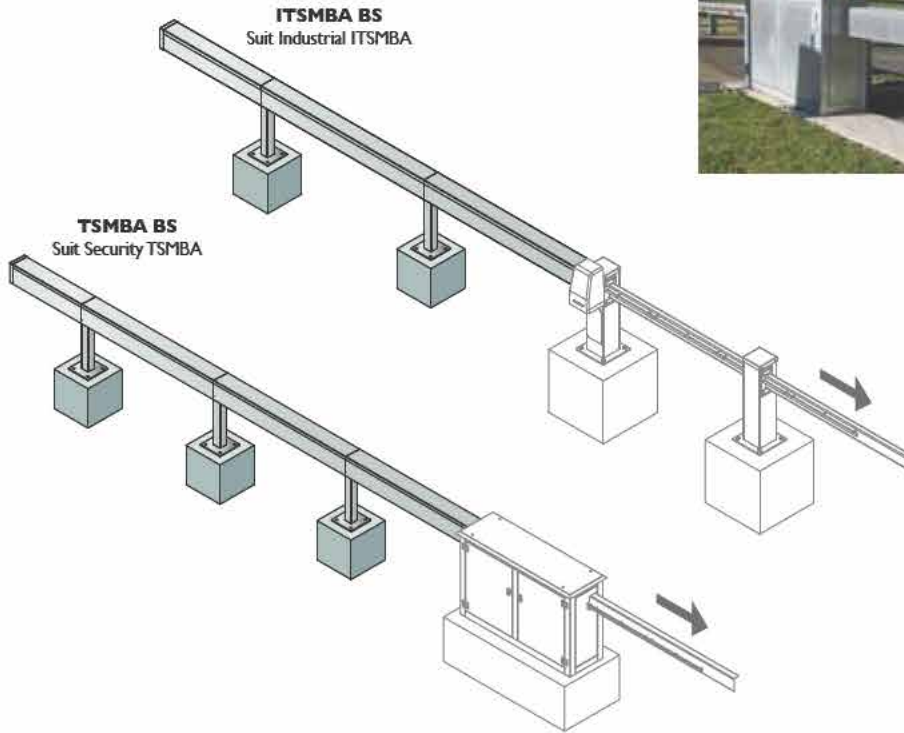

Intro	2
Gates	14
Track	20
Cantilever	30
Swing	40
Bi-fold	46
Boom	52
Options	76
General	82
Barriers	94
Blockers	100
Tyre Spikes	102
Pre-cast	106
Other	111
Pedestrian	114
Turnstiles	114
Gates & Doors	136
Fencing	142
Code Index	153



As with all automated products, Leda highly recommends consideration be given to a preventative maintenance program (PMC), designed to suit the equipment and site conditions. Refer to p93 for details.

## Product Range > Gates > Options & Accessories

☎ 1300 780 450





Leda recognises the importance of their gates providing you with all your operational requirements and the maximum service life possible. Experienced Leda staff will visit your site to acquaint themselves with the parameters needed to provide you with recommended proposals. Leda will also discuss with you the numerous options available, including:

- OH&S requirements and options
- Gate infills
- Gate top extensions
- Drive systems – motors and gear boxes
- Power – mains or solar.

The majority of these options will be driven by:

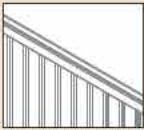
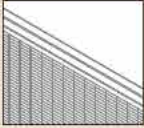
- The level of security required
- The estimated daily operational requirements.

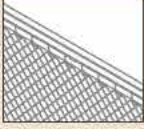
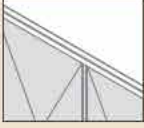
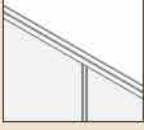
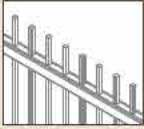
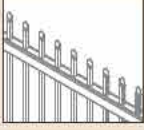
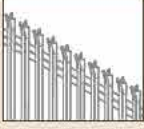
<b>Finish Options</b> <i>Standard gate finish is hot dipped galvanised.</i>	
<b>Industrial</b>	
GALCERT	Certificate from hot dipped galvanised to Australian Standards.
IHDGATE	Industrial gate heavy duty wet spray finish. Total m <sup>2</sup> is gate opening width x gate height. Includes painting on both sides, posts and motor cabinet if required. Abrasive blast ASI627.4 Class 2.5, Zincode 402 to 75um, Weathermax HBR to 75um.
IPCGATE	Industrial gate powder coated finish. Total m <sup>2</sup> is gate opening width x gate height. Includes painting on both sides, posts and motor cabinet if required.
ISDGATE	Industrial gate standard duty wet spray finish. Total m <sup>2</sup> is gate opening width x gate height. Includes painting on both sides, posts and motor cabinet if required. Abrasive blast ASI627.4 Class 1.0, Durmax GPE to 75um, Luxethane to 50um.
<b>Security</b>	
SHDGATE	Security gate heavy duty wet spray. Total m <sup>2</sup> is gate opening width x gate height. Includes painting on both sides, posts and motor cabinet if required. Abrasive blast ASI627.4 class 2.5, Zincode 402 to 75um, Weathermax HBR to 75um.
SPCGATE	Security gate powder coated finish. Total m <sup>2</sup> is gate opening width x gate height. Includes painting on both sides, posts and motor cabinet if required.
SSDGATE	Security gate standard duty wet spray finish. Total m <sup>2</sup> is gate opening width x gate height. Includes painting on both sides, posts and motor cabinet if required. Abrasive blast ASI627.4 class 1.0, Durmax GPE to 75um, Luxethane to 50um.

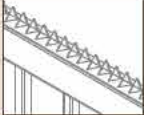
<b>Gate Infills</b>		
STANDARD		Square Pickets 25 x 25mm RHS. Standard infill.
MESHGATE		Securamesh Steel Mesh anti-climb, 71 x 9mm opening
PALGATE		Palisade Pickets to suit Palisade fencing.
CHAINGATE		Chain Link Mesh
ZINCGATE CBGATE		Zincalume Steel Panels or Colorbond® Steel Panels
GLGATE		Security Glass Panel
<b>Gate Top Extensions</b>		
TF		Flat Picket finish to match gate finish. 200mm high
TC		Crimped Picket 200mm high
TP		Palisade Picket to suit Palisade fencing. 200mm high
TR		Razor Wire 450mm diameter, flat loop, short barbed. 500mm high
TB		Barbed Wire 3 strands. 500mm high
TH		Shark Tooth Plate 25mm high



☎ 1300 780 450



**Drive Systems**

A range of various drive motors / gear boxes is available to suit the weight of the gate and the proposed application and expected usage.

Drive motors can be either mains or solar powered and should include:



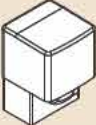
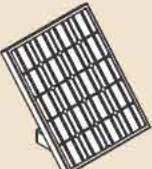

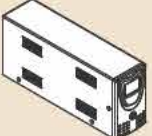





- Adjustable opening and closing speeds.
- Limit or proximity switches for position sensing.
- Manual override in the event of a power outage.
- Controlled by a purpose-built control board or PLC (Programmable Logical Controller).
  - allowing linkages to a range of peripheral applications like alarms and strobe lights.
  - interfacing with common access control systems.
- High speed retracting ability – achieving up to 1 metre per second gate speed.

**Drive Options**

 <p><b>TOPTIER</b></p>	<p>Top tier slide gate auto option. Suitable for high duty cycle sites, heavy security gates and faster operating speeds of 300-600mm / sec.</p>
 <p><b>MIDTIER</b></p>	<p>Mid tier slide gate auto option. Suitable for low-medium duty cycles, low to medium weights and safer operating speeds of approx 200mm / sec.</p>
  <p><b>SOLAR</b></p>	<p><b>Solar Power</b> 10W photovoltaic cell panel with safety glass (290 x 354mm). Control Box – 2 x 12V 7.2Ah batteries. Best suited for smaller gates or infrequent operation (less than 20 operations / day) and where mains power is not available.</p> <ul style="list-style-type: none"> <li>• Park entrances &amp; remote locations</li> <li>• Mining sites</li> <li>• Low-use industrial</li> </ul> <p>Used in conjunction with low voltage drive motors – see Gate Motors table on p81 for compatibility.</p>
<p><b>SOLAR B</b> <b>SOLAR G</b> <b>SOLAR T</b></p>	<p>For track gates 240V AC For track gates 24V DC For turnstiles 240V AC</p>
 <p><b>UPS</b></p>	<p>Uninterrupted power supply to suit the current draw and cycle requirements in the event of power failure. Various options available to suit site requirements.</p>

**Access Control**

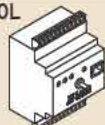



Leda supply and install basic systems for Leda equipment only. All Leda equipment can integrate with any type of 3rd party security system or access control system.



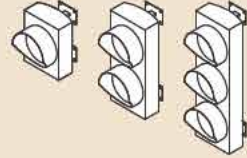

 <p><b>GSM1</b></p>	<p><b>GSM gate kit allows authorised users to call the gate to open or close it.</b> The Basic system allows for the control of authorised users without an audit function.</p>
 <p><b>GSM3</b></p>	<p>Intercom Kit. Stainless steel intercom face with push button activation.</p>
 <p><b>REMOTE1</b></p>	<p>Remote control system with aerial, receiver and two transmitters. Basic functionality with no audit.</p>
<p><b>REMOTE2</b></p>	<p>Remote control system with aerial, receiver and two transmitters. Screen programming and reporting.</p>
<p><b>REMOTE3</b></p>	<p>Remote control system with aerial, receiver and two transmitters. Laptop plug in for control and reporting.</p>
 <p><b>PROX</b></p>	<p>Programmable proximity cards. (Contactless access control)</p>
 <p><b>GATETIMER</b></p>	<p>Additional time settings for operations before or after an event. Eg. 'open every morning at 6am' or 'close 60 minutes after an event'.</p>
<p><b>GATETIMERCAL</b></p>	<p>Calendar-based timing to consider weekends and public holidays.</p>
 <p><b>PB</b></p>	<p>Push button controller.</p>
 <p><b>KS</b></p>	<p>Key switch controller. Sprung or hold to operate options.</p>
 <p><b>PIN</b></p>	<p>PIN code entry numerical pad.</p>
 <p><b>PL400L</b></p>	<p>24V Universal interface.</p>
 <p><b>PBEMERG</b></p>	<p>Emergency gate release kit. User breaks glass to activate emergency gate access / exit.</p>

<b>Intro</b>	<b>2</b>
<b>Gates</b>	<b>14</b>
Track	20
Cantilever	30
Swing	40
Bi-fold	46
Boom	52
Options	76
General	82
<b>Barriers</b>	<b>94</b>
Blockers	100
Tyre Spikes	102
Pre-cast	106
Other	111
<b>Pedestrian</b>	<b>114</b>
Turnstiles	114
Gates & Doors	136
<b>Fencing</b>	<b>142</b>
<b>Code Index</b>	<b>153</b>

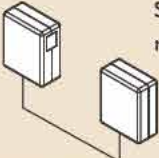
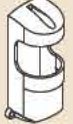
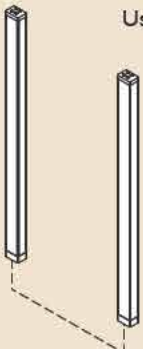



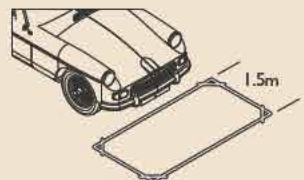
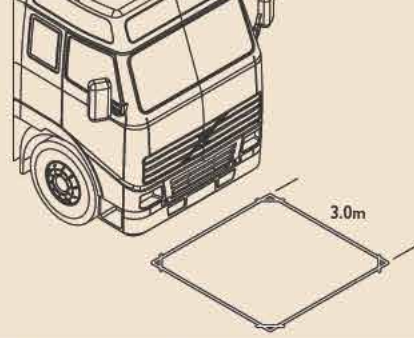

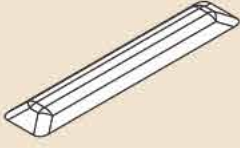
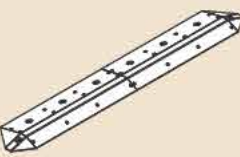



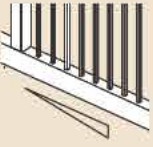

☎ 1300 780 450

Safety Options	
FLA001	Flashing light 360° 
SIREN	Audible warning siren for automated equipment 
SIRENB	Flashing light, siren combined 
LTLLED1	LED Traffic Light (Red or Green)
LTLLED2	LED Traffic Light (Red / Green)
LTLLED3	LED Traffic Light (Red / Amber / Green) 
GATEBUMP	Bump strip for leading edge of gate or door. Pneumatically operated so any obstruction encountered should force the gate to stop and/or retract. 
PEBEAM1	Photo Electric Beam. Single point to point polarised mirror beam. 
PEBEAM2	Photo Electric Beam. Single point to point send and receive beam – cable required. 
PESHROUD	Cast aluminium protective shroud for PE Beam 
PEBEAMGRID	Photo electric light grid, 1000mm high. Used to optimise safety. 

Safety Options	
PEBEAMARRAY	PE Beam light array where multi PE Beams can be linked. 
PEBEAMLZR	Programmable laser beam curtain. 10m x 10m. 
LOOPDECT	Single channel 230V AC loop detector. 
LOOPCAR	Road loop optimised for cars and vans. Induction cable is cut 50mm deep into road surface at least 1500mm in length. Cable is sealed in road and connects to an additional loop detector. 
LOOPTRUCK	Road loop optimised for larger vehicle detection such as trucks and buses. Installation as above. 
ISTD	Surface mounted vehicle detector. Magnetic sensor alternative option to conventional loop detectors. 
SHUMPASPH	Speed hump, 120mm height. For installation on asphalt surfaces. 
HUMPMS	Mild steel bolt down speed hump. 

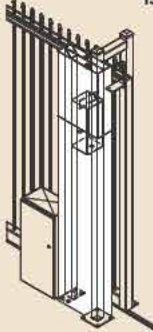
☎ 1300 780 450









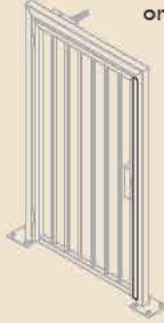

Gate Accessories	
<p><b>LGCC</b></p> 	<p>Standard gate control cabinet, finish to gate finish. Includes isolator, GPO, mounting block, perspex window to meet Australian Standards. This is an optional extra for clients requiring additional room for access control equipment, etc. It is a beneficial work space for service during inclement weather which is often overlooked when going with a standard gate motor with removable hood.</p>
<p><b>LGIBSF</b></p> 	<p>Industrial gate bi-slide kit and fitting to enable bi-slide on one gate only. This is the fixed component and a per metre rate (L GIBSI) is addition. Bi-parting gates will need two. Please note: due to the speed and type of gate, it is highly recommended.</p>
<p><b>LGIBSI</b></p> 	<p>Industrial gate bi-slide kit per metre. (These are the additional rollers and pulleys required on the 2nd leaf, including labour charges.)</p>
<p><b>LGSBSF</b></p> 	<p>Security gate bi-slide kit per metre. (These are the additional rollers and pulleys required on the 2nd leaf, including labour charges.)</p>
<p><b>LGR</b></p> 	<p>Additional gate raking charge per gate. Includes drawing issue for client and sign-off and additional production labour to rake to ordered angle.</p>
<p><b>LGDAMP</b></p> 	<p>Gate Damper. For OH&amp;S reasons Dampers are recommended for track sliding gates installed on sloping ground. Restricts the gate speed during manual operation or in the event of power failure. Designed for loads up to 7Nm.</p>

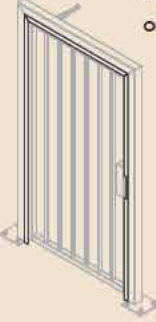
Gate Accessories	
<p><b>SC</b></p> 	<p>Security column receiving post that gate penetrates when in the closed position.</p>
<p><b>CTRWGH</b></p> 	<p>Counter weighting of gates is an option for raked gates.</p>
Gate Spares	
<p><b>FLROLLER</b></p> 	<p>Flanged roller assembly mounted at base of tunnel for gate to slide on. Fully assembled with bearings, fixing nuts and bolts.</p>
<p><b>GDROLLER</b></p> 	<p>Black metal guide roller assembly complete with bearings, fixing nuts and bolts.</p>
<p><b>NROLLER</b></p> 	<p>Nylon roller assembly mounted at front of gate. Fully assembled with bearings, fixing nuts and bolts.</p>
<p><b>PLROLLER</b></p> 	<p>Plain roller assembly mounted at rear of gate, for gate to slide on running rail.</p>

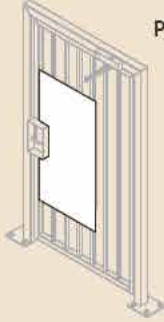
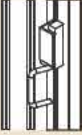
<b>Intro</b>	<b>2</b>
<b>Gates</b>	<b>14</b>
Track	20
Cantilever	30
Swing	40
Bi-fold	46
Boom	52
Options	76
General	82
<b>Barriers</b>	<b>94</b>
Blockers	100
Tyre Spikes	102
Pre-cast	106
Other	111
<b>Pedestrian</b>	<b>114</b>
Turnstiles	114
Gates & Doors	136
<b>Fencing</b>	<b>142</b>
<b>Code Index</b>	<b>153</b>

## Product Range > Gates > Options & Accessories

© 1300 780 450

Pedestrian Gate Accessories		Pedestrian Gate Accessories	
DDLOCK	Lockwood slimline mortice lock kit including barrels & handles.	DDJAMB	Pedestrian swing gate door jamb bracket attached to gate to physically stop gate or access to lock tongue.
			
DDFREE	Free-to-exit setup for DDLOCK. Includes handle shroud to stop reach-around. Must add MESHGATE to gate and adjacent fence panel to prevent people reaching around and using free-to-exit handle. Must also have DDLOCK in sales order.	DDJAMF	Pedestrian gate door frame bracket attached to frame to physically stop gate or access to lock tongue.
			
ES200	Electric strike to suit DDLOCK.	DDSCREEN	Polycarbonate screen around door lock to prevent reach-around access. Commonly used for free-to-exit pedestrian doors.
			
DDMAG	Electronic magnetic lock, fabricated brackets & handles.	SHCP20	Stainless steel hinged cover plate for manual gate locking bolt.
			
DDPAD	Horizontal sliding padbolt (1000 high) for locking gate (padlock not included).	PGDB32	Key locking drop bolt
			
DDDROP	Vertical drop bolt 12mm. For locking gate in the open position.		
			
TS8300 SIL	Dorma automatic door closer (only available on gates with top frame – SWSC).		
			



☎ 1300 780 450

**Gate Motors**

Duty Level	Gate Code	Duty	Motor Code	Operations Per Day	Opening Speed (mm/sec)	Max Leaf Length (m)	Max Leaf Weight (kg)	Motor Size (W)	Control Type
<b>Track Gates</b>									
<b>Advantage</b>	ATS	Light Solar	MOTSLLS	<6	150	6	250	80	Basic Logic
		Light	MOTSLL	<10	200	6	1000	750	Basic Logic
	AMTS	Light Solar	MOTSLLS	<6	150	6	250	80	Basic Logic
		Light	MOTSLL	<10	200	6	1000	750	Basic Logic
<b>Industrial</b>	ITS	Light	MOTSLL	<10	200	6	1000	750	Basic Logic
		Mid	MOTSML	10-50	450	8	800	550	Invertor & CB6
	ITSH	Light	MOTSLL	<10	200	6	1000	750	Basic Logic
		Mid	MOTSML	10-50	450	8	800	550	Invertor & CB6
RTS	Mid	MOTSML	10-50	450	6	800	550	Invertor & CB6	
	High	MOTSLH	50+	630	6	2000	750	Invertor & CB6	
<b>Security</b>	TMS	Mid	MOTSML	10-50	450	8	800	550	Invertor & CB6
		High	MOTSLH	50+	630	12	2000	750	Invertor & CB6
<b>High Security</b>	TMSH	High	MOTSLH	50+	600	12	2000	750	Invertor & CB6
<b>Anti-Terrorist</b>	CGT	High	MOTSLH	50+	630	5	2000	750	Invertor & CB6
<b>Cantilever Gates</b>									
<b>Advantage</b>	CLA	Light Solar	MOTSLLS	<6	150	6	250	80	Basic Logic
		Light	MOTSLL	<10	200	6	1000	750	Basic Logic
<b>Industrial</b>	ICL	Light	MOTSLL	<10	200	6	1000	750	Basic Logic
		Mid	MOTSML	10-50	450	8	800	550	Invertor & CB6
	ICLM	Light	MOTSLL	<10	200	6	1000	750	Basic Logic
		Mid	MOTSML	10-50	450	8	800	550	Invertor & CB6
ICLU	Light	MOTSLL	<10	200	6	1000	750	Basic Logic	
	Mid	MOTSML	10-50	450	8	800	550	Invertor & CB6	
CG12	Light	MOTSLH	50+	600	9	2000	750	Invertor & CB6	
	Mid	MOTSLH	50+	600	9	2000	750	Invertor & CB6	
<b>Security</b>	CLS	Mid	MOTSML	10-50	450	8	800	550	Invertor & CB6
		High	MOTSLH	50+	630	10	2000	750	Invertor & CB6
<b>High Security</b>	CLSH	High	MOTSLH	50+	630	10	2000	750	Invertor & CB6
<b>Single Swing Gates (seconds)*</b>									
<b>Premier</b>	FPSS	Light	MOTSWSL	<10	17	2	300	250	Basic Logic
		Mid	MOTSWSM4	10-50	7-10	4	400	180	Invertor
<b>Advantage</b>	ASS	Light Solar	MOTSWSL	<5	17	2	300	40	Basic Logic
		Light	MOTSWSL	<10	17	2	300	250	Basic Logic
<b>Industrial</b>	ISS	Light Solar	MOTSWSL	<5	17	2	300	40	Basic Logic
		Light	MOTSWSL	<10	17	2	300	250	Basic Logic
	Mid	MOTSWSM4	10-50	7-10	4	400	180	Invertor	
		MOTSWSM6	10-50	8-10	6	500	370	Invertor	
RSS	Mid	MOTSWSM4	10-50	7-10	4	400	180	Invertor	
	Mid	MOTSWSM6	10-50	8-10	6	500	370	Invertor	
<b>Security</b>	SWS	Mid	MOTSWSM4	10-50	7-10	4	400	180	Invertor
		Mid	MOTSWSM6	10-50	8-10	6	500	370	Invertor
	High	MOTSWSH7	50+	8-10	7	600	370	Invertor	
		MOTSWSH8	50+	12-15	8	800	750	Invertor	
<b>Dual Swing Gates (seconds)*</b>									
<b>Premier</b>	FPSD	Light	MOTSWDL	<10	17	2	300	250	Basic Logic
		Mid	MOTSWDM4	10-50	7-10	4	400	180	Invertor
<b>Advantage</b>	ASD	Light Solar	MOTSWDLS	<5	17	2	300	40	Basic Logic
		Light	MOTSWDL	<10	17	2	300	250	Basic Logic
<b>Industrial</b>	ISD	Light Solar	MOTSWDLS	<5	17	2	300	40	Basic Logic
		Light	MOTSWDL	<10	17	2	300	250	Basic Logic
	Mid	MOTSWDM4	10-50	7-10	4	400	180	Invertor	
		MOTSWDM6	10-50	8-10	6	500	370	Invertor	
RSD	Mid	MOTSWDM4	10-50	7-10	4	400	180	Invertor	
	Mid	MOTSWDM6	10-50	8-10	6	500	370	Invertor	
<b>Security</b>	SWD	Mid	MOTSWDM4	10-50	7-10	4	400	180	Invertor
		Mid	MOTSWDM6	10-50	8-10	6	500	370	Invertor
	High	MOTSWDH7	50+	8-10	7	600	370	Invertor	
		MOTSWDH8	50+	12-15	8	800	750	Invertor	
<b>High Security</b>	SWSV	Mid	MOTSWDH8	50+	12-15	8	800	750	Invertor
		High	MOTSWDH8	50+	12-15	8	800	750	Invertor

Intro	2
Gates	14
Track	20
Cantilever	30
Swing	40
Bi-fold	46
Boom	52
Options	76
General	82
Barriers	94
Blockers	100
Tyre Spikes	102
Pre-cast	106
Other	111
Pedestrian	114
Turnstiles	114
Gates & Doors	136
Fencing	142
Code Index	153

\* Time in seconds for gate to fully open – ie. 90° from closed position.

☎ 1300 780 450



### Occupational Health & Safety

Leda's gate range is manufactured from strong, durable, corrosion-protected steel and has long been considered the industry standard.

> Refer to Features of Leda gate technology, p16-17.

With some gates weighing more than 500kg, Leda also treats Occupational Health & Safety issues seriously, and includes features in all gates to minimise accidental injury in risk areas.

Leda offers a range of optional mechanical and electronic accessories to foster an accident-free working environment.

> Refer to p78 for safety options.



### Intrinsic Safety Options

Intrinsic safety (IS) is a protection technique for safe operation of electronic equipment in explosive atmospheres and under irregular operating conditions.

Intrinsic safe options are required wherever flammable products are generated, prepared, processed, handled, stored or otherwise used. Australian standards are available to determine the classification of all sites and Leda will supply to the appropriate standard at a particular site. Typical sites include:

- Gas works and ports
- Certain mine sites
- Explosives storage
- Petro-chemical plants or storage areas



Such sites are also subject to heightened security safeguards requiring many of the perimeter security solutions that Leda is able to provide.

Relevant industries are well aware of the high standards required during design, manufacture, installation and ongoing service. Leda has a proven track record on supplying to these strict standards and is able to offer certified intrinsically safe solutions.

For further information on intrinsically safe equipment, be sure to ask a Leda product specialist. Client references and certification are available upon request.

**Crushing Point** Areas that could potentially cause injury when the gate is being opened or closed. In particular, the area between the main and opposing closing edge.



**Closing Edges** Main. Edge of a gate leaf, whose distance from the parallel opposing edge determines the usable aperture. Opposing. Edge formed by the main closing edge of a counter closing leaf, a fixed edge or a surface against which the gate leaf is moving.



**Trapping Point** Areas that could catch someone while the gate is moving and pull them towards crush points.



**Shearing Points** Points at which a person may be at risk of injury through shearing between fixed and moving areas, i/e bars on the gate and guide post.



**Automatic** Automatic starting machinery.



**Tripping Point** Protruding edges or rails that may cause tripping.





1300 780 450

**Caution Signs**

Leda can also supply custom designed signs for site specific conditions.

450 x 300 Aluminium  
(displayed at larger scale for clarity)



GSC01

130 x 185 Aluminium  
(displayed at larger scale for clarity)



GSC10

1000 x 500 Aluminium



GSC02

1000 x 500 Corflute



GSC03

400 x 500 Aluminium



GSC06



GSC07

400 x 500 Aluminium



GSC04

500 x 300 Corflute



GSC05



GSC08



GSC09

BOOM GATE SIGN  
1500 x 300 PVC Canvas



GSC11

**General Signs**



GGS01



GGS02

300 x 125 Aluminium



GGS08



GGS09 (Blank)



GGS03

300 x 450 Aluminium



GGS04



GGS05



GGS06



GGS07

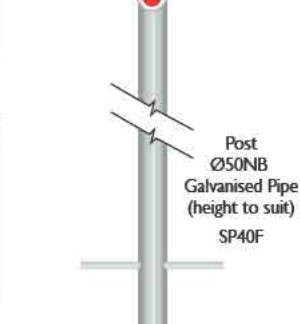

Intro	2
Gates	14
Track	20
Cantilever	30
Swing	40
Bi-fold	46
Boom	52
Options	76
General	82
Barriers	94
Blockers	100
Tyre Spikes	102
Pre-cast	106
Other	111
Pedestrian	114
Turnstiles	114
Gates & Doors	136
Fencing	142
Code Index	153



☎ 1300 780 450

### Entry & Exit Signs

300 x 450 Aluminium



GSE01



GSE02

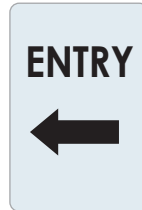

GSE03

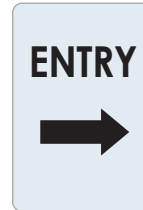

GSE04

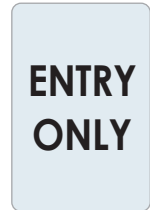

GSE05



GSE06



GSE07



GSE08



GSE09



GSE10



GSE11



GSE12



GSE13



GSE14

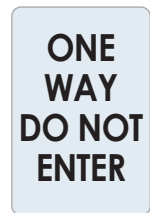

GSE15

### Speed Control Signs



GSS01



GSS02



GSS03



GSS04



GSS05

### Warning Signs



GSW01



GSW02



GSW03



GSW04



GSW05

1300 780 450

**Stencils**

Designs are indicative only – actual product may vary  
Nominal maximum size 1000 x 1000



Stencil BS04



Stencil BS05



Stencil BS06



Stencil BS07



Stencil BS08



Stencil BS09



Stencil BS10



Stencil BS11



Stencil BS12

<b>Intro</b>	<b>2</b>
<b>Gates</b>	<b>14</b>
Track	20
Cantilever	30
Swing	40
Bi-fold	46
Boom	52
Options	76
General	82
<b>Barriers</b>	<b>94</b>
Blockers	100
Tyre Spikes	102
Pre-cast	106
Other	111
<b>Pedestrian</b>	<b>114</b>
Turnstiles	114
Gates & Doors	136
<b>Fencing</b>	<b>142</b>
<b>Code Index</b>	<b>153</b>

# General > Product Checklist

☎ 1300 780 450

It is important that you, the client, has every opportunity to consider all the operational requirements of the automated barrier or gate that you intend to install.

Additionally, you need to be aware of the limitations of the equipment and/or any options that might be available which will enhance and improve the equipment performance and meet all requirements.

Leda provides checklists on all its automated equipment to ensure that the required information is collected before working drawings are commenced.

## Typical pedestrian gate checklist

**HINGE ORIENTATION LAYOUT**

LH - Out     LH - In     RH - Out     RH - In

**FINISH (choose 1 only)**

- Hot Dip Galvanized
- Powdercoated - Colour: \_\_\_\_\_
- 2 Pack Wet Painted - Colour: \_\_\_\_\_

SPIN 18, 21 or 24 Industrial Duty  
SPIN 18, 21 or 24 Normal Duty

**LOCKING MECHANISM (Choose 1 type only)**

- Slimline Mortice Lock (choose options below)  
DOLCK
- Maglock  
DGM40
- Sliding Pad Bolt (padlock not supplied)  
DOPAD

**MORTICE LOCK OPTIONS**

- Free to Exit (includes handle shroud)  
DIFREE
- Key Lockable
- Handles Both Sides
- Handle Secure Side Only
- Electric Strike  
ES200  
(Allows access control with mechanical override)

**INFILL**

- Vertical Uprights (Standard)
- Palisade  
PALGATE18, 21 or 24
- Coloursbond  
CBGATE18, 21 or 24
- Securamesh  
MEASHGATE18, 21 or 24

**ACCESSORIES**

- Door Closer (available with SWSC outer frame only - see sheet 1)  
FSB300 SE
- Vertical Drop Bolt (for holding/locking the gate in the open position)  
DZDRBP

**CHAINWIRE**

- Chainwire
- Welded General Purpose Mesh  
1) 100 x 100    2) 80 x 80
- Other: \_\_\_\_\_

**TOP SECTION**

- TN - No Top Section (std)
- TC - Crimped Picket
- TF - Flat Top Pickets (Plastic Cap Provided)
- TB - Barbed Wire (Three Strands)
- TR - Razor Wire (800mm Flat cap, Short Barbed, 3 Strands Barbed Wire)

1475  
1000 OPENING  
500 200

1475  
1000 OPENING  
500 200

TN = 0  
TB = 500  
TR = 500  
TC = 200  
TF = 200

LH GATE SHOWN WITH MAGLOCK & DOOR CLOSER OPTION (SECURED SIDE VIEW)

A 2100 (TN)  
B  
C  
500 650 500

SWSC - Outer Frame  
 Fixed  Baseplate (shown)

LH GATE SHOWN WITH SLIMLINE MORTICE LOCK OPTION (SECURED SIDE VIEW)

A (TN)  
B  
C  
500 650 500

SWS - 2 Post  
 Fixed  Baseplate (shown)

MATERIAL DESCRIPTION:		ISSUED FOR: CUSTOMER APPROVAL		DRAWN:																
FINISH:	WEIGHT: kg	JOB No.	CLIENT:	APPROVED:																
SCALE: NOT TO SCALE	SW FILE:	MODEL DESCRIPTION: PEDESTRIAN GATES - CHECKLIST		EFFECTIVE DATE:																
<table border="1" style="width: 100%; border-collapse: collapse;"> <tr> <th colspan="2">LINEAL TOLERANCES</th> <th colspan="2">ANGULAR TOLERANCES</th> </tr> <tr> <td>1 to 250</td> <td>250 to 500</td> <td>90 to 1350</td> <td>1000 to 6000</td> </tr> <tr> <td>± 0.2</td> <td>± 0.5</td> <td>± 1.0</td> <td>± 2.5</td> </tr> </table>		LINEAL TOLERANCES		ANGULAR TOLERANCES		1 to 250	250 to 500	90 to 1350	1000 to 6000	± 0.2	± 0.5	± 1.0	± 2.5	<table border="1" style="width: 100%; border-collapse: collapse;"> <tr> <td>ITEM:</td> <td>INDEX:</td> <td>REV:</td> <td>5</td> </tr> </table>	ITEM:	INDEX:	REV:	5	DRAWING DATE:	
LINEAL TOLERANCES		ANGULAR TOLERANCES																		
1 to 250	250 to 500	90 to 1350	1000 to 6000																	
± 0.2	± 0.5	± 1.0	± 2.5																	
ITEM:	INDEX:	REV:	5																	
THIRD ANGLE PROJECTION		SHEET:																		





# General > Rendering Service

☎ 1300 780 450

Leda's design team prides itself on the ability to provide high quality renderings that provide a clear picture of what the proposed site will look like when the product is installed and the project is completed.

This is particularly helpful when assessing the visual impact a proposed installation will have on the aesthetics of a site or surrounding area.



## Gates

<b>Intro</b>	<b>2</b>
<b>Gates</b>	<b>14</b>
Track	20
Cantilever	30
Swing	40
Bi-fold	46
Boom	52
Options	76
General	82
<b>Barriers</b>	<b>94</b>
Blockers	100
Tyre Spikes	102
Pre-cast	106
Other	111
<b>Pedestrian</b>	<b>114</b>
Turnstiles	114
Gates & Doors	136
<b>Fencing</b>	<b>142</b>
<b>Code Index</b>	<b>153</b>

## General > Installation Details

☎ 1300 780 450

One of the most overlooked aspects of a good gate installation is the footing design. Besides impact from motor vehicles – either accidental or intentional – gates can be exposed to high wind loadings (depending on which region in Australia they are being installed), and this potential live load on the structural support and footings needs to be taken into account. Gate installations carried out by unqualified and/or inexperienced suppliers is a common problem that Leda is often requested to rectify.



Leda footings are designed by Leda's civil engineers to ensure they meet the required structural and Australian standards for wind loadings. This often makes Leda footings larger than those of many inexperienced suppliers and marginally more costly, but for good reason.

Where Leda is not required to pour the concrete footings, detailed footing designs, along with steel reinforcing schedules will be provided.

As with all high security equipment installations, correct anchoring of the barriers is critical. The engineering supporting the necessary concrete footings is highly confidential and will only be provided once a contract has been entered into to supply, or supply and install, Leda's equipment.



**Typical Concrete Footings & Steel Reinforcement**  
Cantilever gate displayed

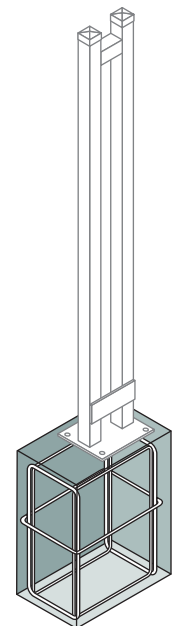
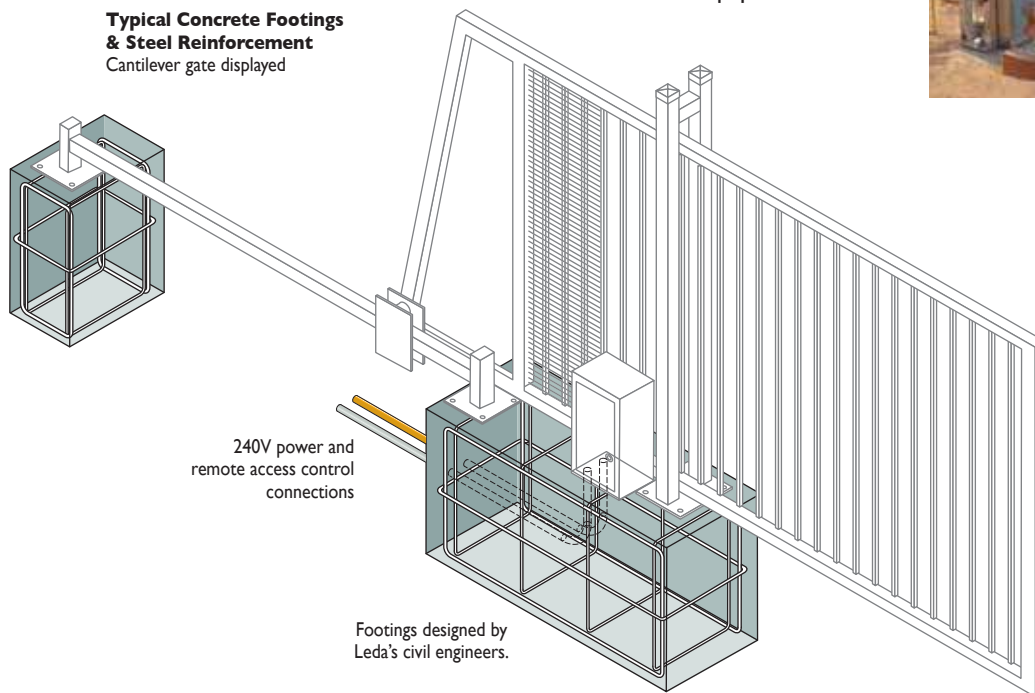

Concrete footings preparation for swing gates

General > Installation Details

1300 780 450

**Intro** 2

**Gates** 14

Track 20

Cantilever 30

Swing 40

Bi-fold 46

Boom 52

Options 76

General 82

**Barriers** 94

Blockers 100

Tyre Spikes 102

Pre-cast 106

Other 111

**Pedestrian** 114

Turnstiles 114

Gates & Doors 136

**Fencing** 142

**Code Index** 153

**Typical Concrete Footings**

**Track Gates**

Steel reinforcement design by Leda's consulting civil engineers

(Detailed drawings provided for civil works by others)

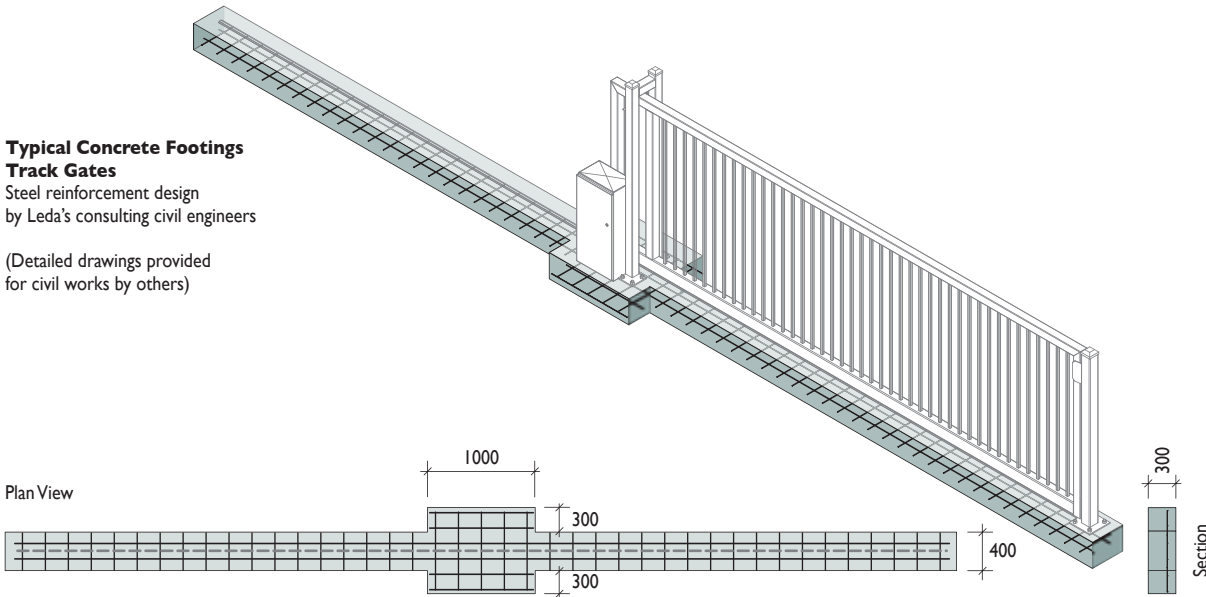

**Typical Concrete Footings**

**Cantilever Gates**

Steel reinforcement design by Leda's consulting civil engineers

(Detailed drawings provided for civil works by others)

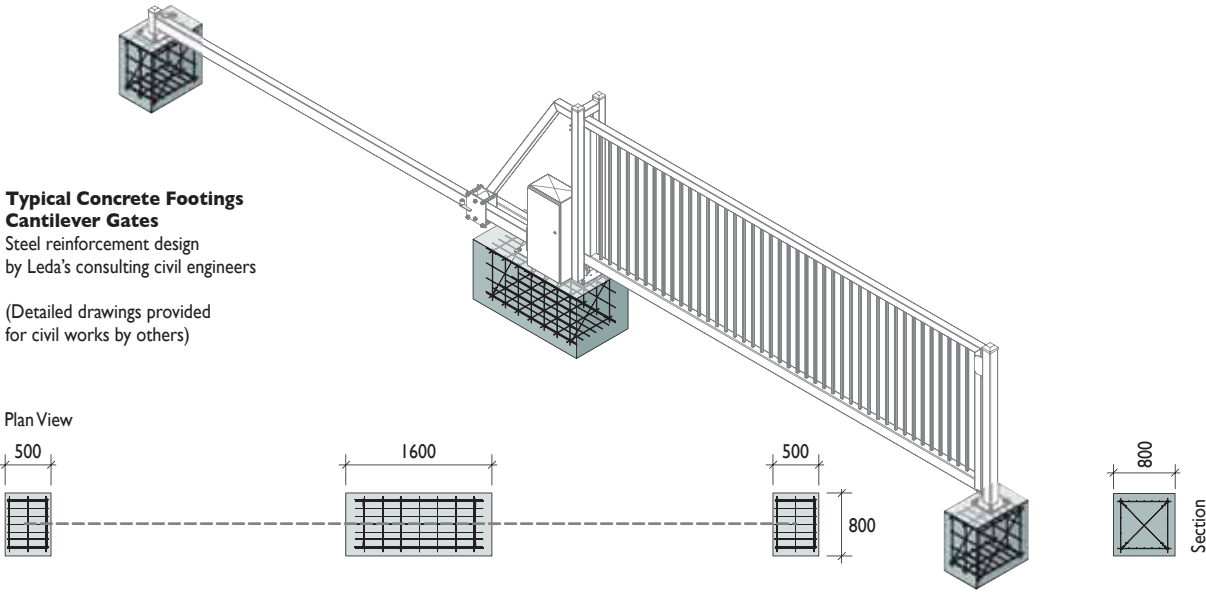

**Typical Concrete Footings**

**Swing Gates**

Steel reinforcement design by Leda's consulting civil engineers

(Detailed drawings provided for civil works by others)

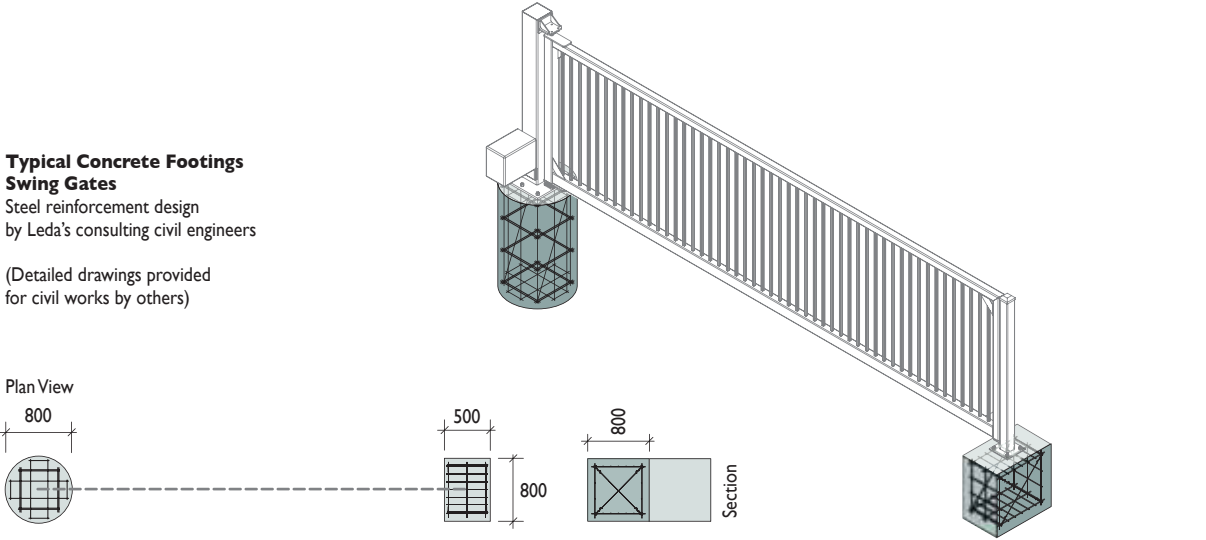



## General > Installation Details > Pre-fabricated

☎ 1300 780 450

As the industry leader in industrial and high security cantilever gates, Leda's engineers are constantly researching and improving footing designs that will provide more convenient, speedier and economical installations.

Excavating and pouring concrete footings insitu is both expensive and a time-consumer while concrete cures. Leda has developed and offers alternative pre-fabricated footing options that provide more economical installations and time savings.

As both systems are considerably shallower than conventional insitu footings, it may also be possible to avoid any excavation by simply sitting the pre-fabricated components directly onto a levelled site.



General > Installation Details > Pre-fabricated

1300 780 450

**Pre-cast Concrete Footings**

2 off, 1600 x 800 x 200 plinths, each 630kg

1 off, 500 x 800 x 200 plinth, 200kg.

**Simple & Economical**

- Simply level the site or dig shallow excavation and add thin sand base for levelling purposes.
- Position the pre-cast bases, locate the equipment on top and align
- Drill the required fixing holes and instal the chemical anchors supplied to complete the installation.

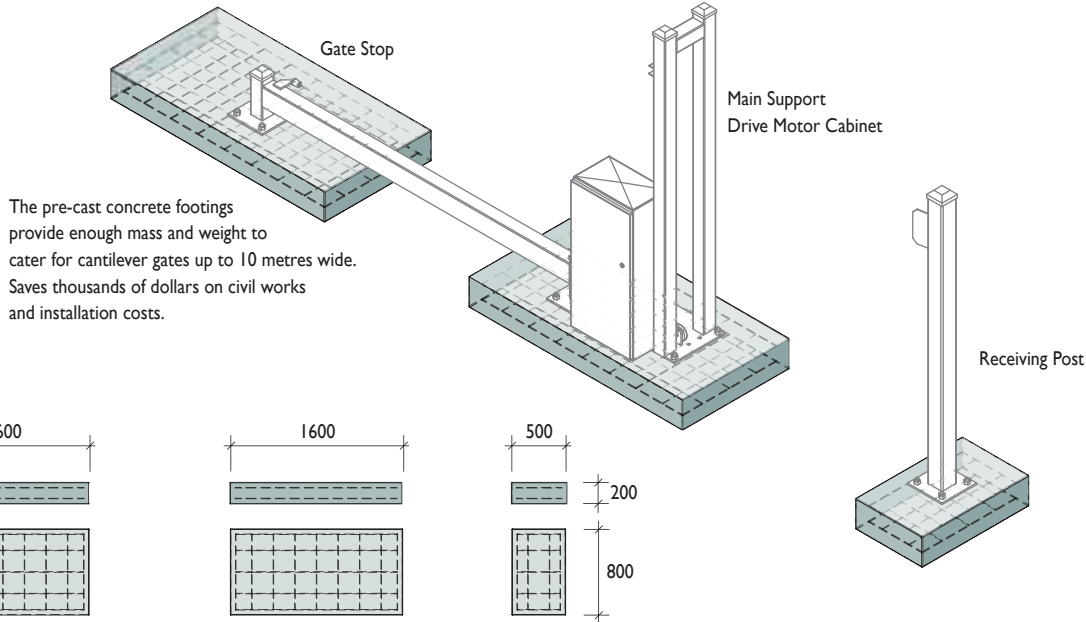

**Shallow Mount Biscuit Footings**

The shallow mount system uses steel biscuits with all fixing points incorporated into the units.

2 off, 1600 x 800 x 120 biscuits

1 off, 500 x 800 x 120 biscuit

Once the biscuits are correctly positioned and the gate equipment installed, the units can be filled with concrete to meet the weight requirement for wind loadings.

Leda's shallow mount biscuit footing option can also provide significant installation cost savings.

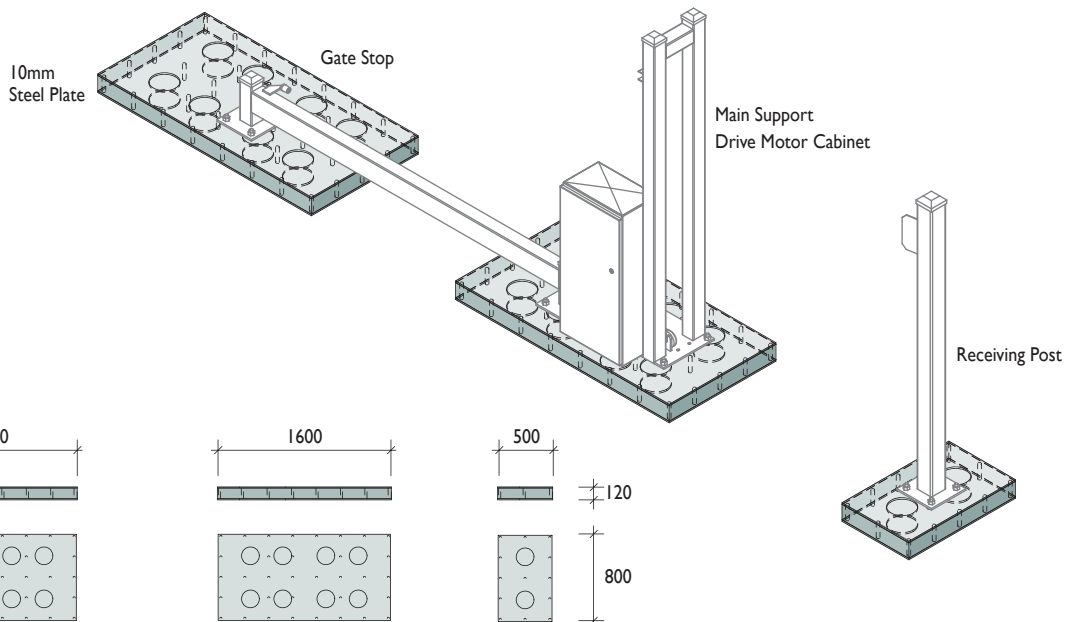

<b>Intro</b>	<b>2</b>
<b>Gates</b>	<b>14</b>
Track	20
Cantilever	30
Swing	40
Bi-fold	46
Boom	52
Options	76
General	82
<b>Barriers</b>	<b>94</b>
Blockers	100
Tyre Spikes	102
Pre-cast	106
Other	111
<b>Pedestrian</b>	<b>114</b>
Turnstiles	114
Gates & Doors	136
<b>Fencing</b>	<b>142</b>
<b>Code Index</b>	<b>153</b>

## General > Transportation

☎ 1300 780 450

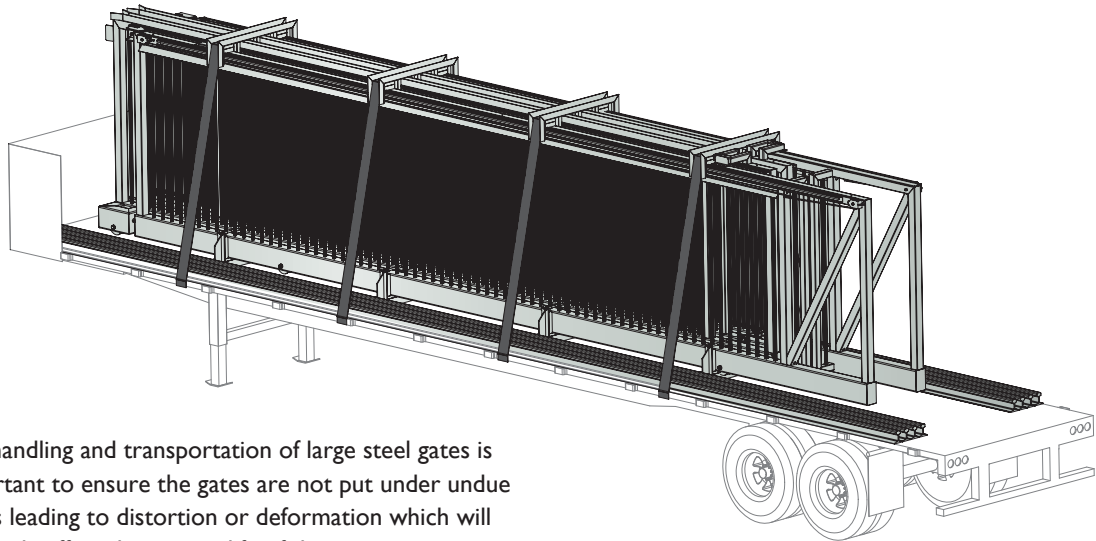

The handling and transportation of large steel gates is important to ensure the gates are not put under undue stress leading to distortion or deformation which will adversely effect the service life of the gate.

Leda staff are trained and experienced in the handling and installation of larger gates, guaranteeing that they arrive at their destination in perfect condition.

Where possible, manufactured gates will be transported in an upright vertical position supported at their quarter points to minimise any possibility of strain or distortion.



Lightweight modular track gates can be loaded onto double pallets providing large freight and transport savings.

Do-it-yourself cantilever gates are economical and easy to transport, particularly to remote locations



1300 780 450



The range of options and accessories on pages 76-80 allows your Leda gate to be tailored to your requirements, incorporating all the functions for ease of operation, and most importantly, compliance with OH&S issues which are often overlooked.

Also, by choosing a Leda gate, you are guaranteed of the highest quality possible, safe in the knowledge that it will provide you with reliable service within the optimum service life of the gate.

Leda has a selection of preventative maintenance programs that can be tailored to your equipment ensuring your gate is kept operational at all times.



## Securacare

There are 3 levels of service in the **Securacare** portfolio to suit individual requirements and budgets while offering a re-assuring after-hours service.

### Gold

Gold membership is a comprehensive agreement which covers you for scheduled and unscheduled maintenance and parts. Critical sites that need 24 hour access will benefit from this level of service which is only available on Leda equipment.

### Silver

Silver membership encompasses preventative maintenance and is our most popular **Securacare** service level. All automated equipment requires preventative maintenance to minimise the chance of inconvenient breakdowns. Regular checks by Leda's technicians also enhances the OH&S on any site.

### Bronze

Bronze membership gives that extra peace-of-mind should you need assistance. A small annual subscription ensures your site's equipment and service record is kept on Leda's database and help is at hand after hours.

#### Additional Information

- **Securacare** is available on all Leda products or third party products by agreement. An initial site review is recommended.
- **Securacare** service is available after hours by arrangement. **Securacare** clients receive priority emergency service. Non **Securacare** service calls will be answered by the next available technician.
- **Securacare** is available in Metropolitan areas within 100 kilometres of a Leda office. Country and regional areas by arrangement.
- **Securacare** service is carried out by Leda trained technicians, and service agents in remote areas. All service is covered by our national response number 1300 780 450.
- **Service Books** – Leda supply a service book which is normally left in the control cabinet. It provides information and details on all services and repairs carried out on your equipment.

<b>Intro</b>	<b>2</b>
<b>Gates</b>	<b>14</b>
Track	20
Cantilever	30
Swing	40
Bi-fold	46
Boom	52
Options	76
General	82
<b>Barriers</b>	<b>94</b>
Blockers	100
Tyre Spikes	102
Pre-cast	106
Other	111
<b>Pedestrian</b>	<b>114</b>
Turnstiles	114
Gates & Doors	136
<b>Fencing</b>	<b>142</b>
<b>Code Index</b>	<b>153</b>

## Product Range > Vehicle Barriers

☎ 1300 780 450

Leda's vehicle barriers and road blockers offer varying degrees of security and impact protection, ranging from low to very high security and impact resistance. They may be installed as single independent units in tandem or in a combination with other products such as gates in order to achieve a sluice arrangement forming a vehicle checkpoint.

The Leda range includes above ground, surface mount, shallow mount or with conventional deep concrete footings.

Vehicle barriers and road blockers provide medium to high levels of security against vehicle-borne impact attacks without compromising on pedestrian safety within pedestrian inclusion areas.

Barriers are also a very effective visual security deterrent when suitably used as a vehicle checkpoint due to their sheer bulk when in armed mode. They are usually painted in highly visible yellow with red warning colours.

Hostile Vehicle Mitigation (HVM) is now a major consideration for engineers and consultants when designing new projects or upgrading existing sites. As the operating specifications can change significantly, Leda's engineers have developed a range of barriers from which to select.

### Applications

- Critical infrastructure
- Petroleum and chemical plants
- Container terminals and wharves
- Embassies and consulates
- High profile government facilities
- Defence bases
- Commercial office buildings

*For further information on impact ratings, please contact your closest Leda sales office where your enquiry will be dealt with by an appropriately qualified Leda staff member.*



**SECURITY  
KI2  
RATED**



**PAS68  
TESTED**

Product	Code	Width Range m	Barrier Height mm	Mount Type
Chain Barrier	CPB10	10.0-16.0	800	n/a
Road Barrier	RBI	4.0	350	Surface Mount
Barrier Bar	VBB	4.0 / 6.0	760	Surface Mount
Barrier in a Box	BIB	Various	Various	n/a
Retractable Gate	RMG50	5.0	920	Shallow Mount
Road Blocker	RB1414	1.4	804	Surface Mount
Road Blocker	RB3014	2.98	804	Surface Mount
Road Blocker	DEF950	2.0 / 2.5 / 3.0	750	Shallow Mount
Road Blocker	SW12	2.6-4.5	1000	Shallow Mount

# Product Range > Vehicle Barriers

☎ 1300 780 450

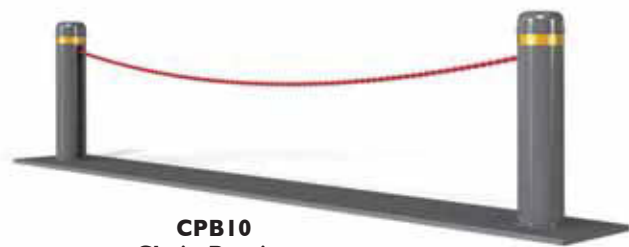

**CPB10**  
Chain Barrier



**RBI**  
Light Duty Road Barrier



**VBB**  
Barrier Bar

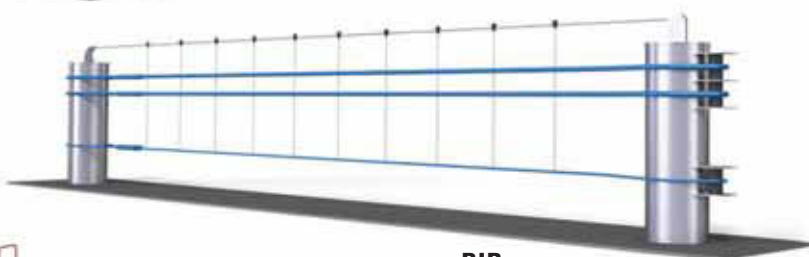

**BIB**  
Barrier in a Box



**RMG50**  
Retractable Gate



**DEF950**  
Road Blocker



**RB3014**  
Road Blocker

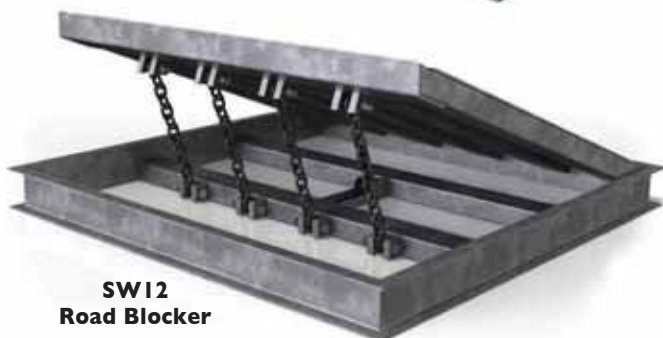

**SW12**  
Road Blocker



**Traffic Lights**



**Flashing Beacon**



**Siren**

Traffic Lights are normally recommended to signal motorists when it is safe to proceed or stop. Flashing Beacons and Sirens are to warn motorists and pedestrians that the blocker is in operation.

## Barriers

<b>Intro</b>	<b>2</b>
<b>Gates</b>	<b>14</b>
Track	20
Cantilever	30
Swing	40
Bi-fold	46
Boom	52
Options	76
General	82
<b>Barriers</b>	<b>94</b>
Blockers	100
Tyre Spikes	102
Pre-cast	106
Other	111
<b>Pedestrian</b>	<b>114</b>
Turnstiles	114
Gates & Doors	136
<b>Fencing</b>	<b>142</b>
<b>Code Index</b>	<b>153</b>



## Product Range > Vehicle Barriers

1300 780 450

### CPB10 Chain Barrier

The Chain Barrier while not designed as a security device, is ideal for the access control of low speed vehicles in parking areas. Similar in principle to a boom gate's operation, the chain can be lowered or raised using a remote control, allowing access to restricted areas. Lowering and raising is controlled by an electric motor in one pilon and a counterweight in the second pilon.

- Easy to install
- 24V motor / battery back-up
- Remote control operation
- LOG-BC control with integrated receiver
- 10 second lower-raise

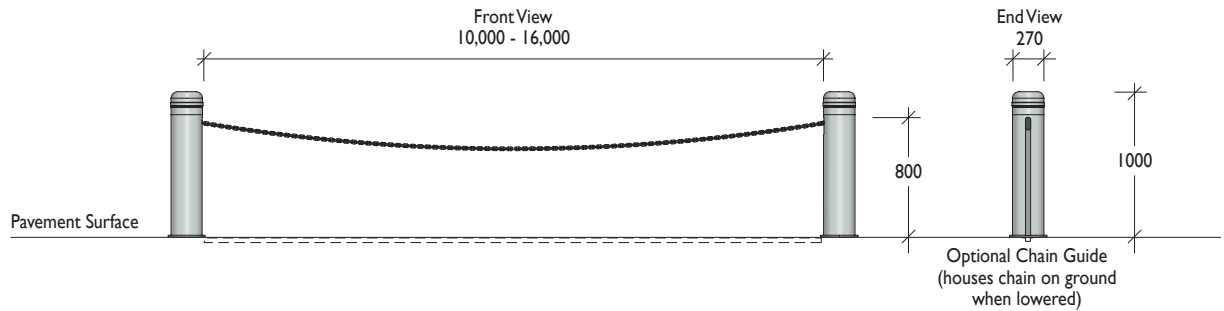
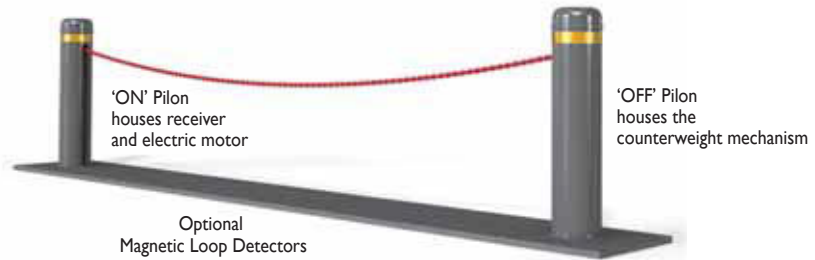

### RB1 Road Barrier

A practical vehicular access control solution that is ideal for temporary or permanent installations. It is easily deployed and operates both as a road blocker and a speed reducing hump.

- Light duty
- Vehicular access control only
- Pneumatic operation
- Temporary or permanent installation
- Speed hump in passive mode

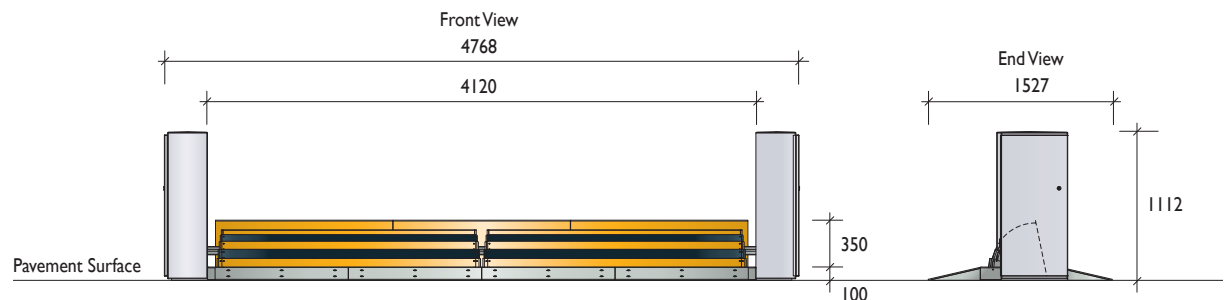

Product Range > Vehicle Barriers

☎ 1300 780 450

**The Vehicle Barrier Bar (VBB)**

The Vehicle Barrier Bar is a unique product providing high impact resistance. Engineered to stop a 7.5 tonne vehicle, the units can be installed in shallow mount concrete footings. The barrier is operated by a robust hydraulic system that raises or lowers the horizontal beam in 3-5 seconds. When in the lowered (or open) position the beam fits flat into a recess in the concrete footing.



commercial buildings in major cities throughout North America and Europe. They provide higher levels of security and are used as the primary vehicle access control, or as back-up to conventional boom gates.

The VBB Barrier is completely at home in hostile environments where sand or ice would make it difficult for alternate barriers to provide reliable operation.

While initially designed to protect defence sites and other government sites, Vehicle Barrier Bars are being increasingly specified and installed in multi-storey

**Applications**

- Embassies
- Government buildings
- Military bases
- Public utilities
- Financial institutions

<b>Intro</b>	<b>2</b>
<b>Gates</b>	<b>14</b>
Track	20
Cantilever	30
Swing	40
Bi-fold	46
Boom	52
Options	76
General	82
<b>Barriers</b>	<b>94</b>
Blockers	100
Tyre Spikes	102
Pre-cast	106
Other	111
<b>Pedestrian</b>	<b>114</b>
Turnstiles	114
Gates & Doors	136
<b>Fencing</b>	<b>142</b>
<b>Code Index</b>	<b>153</b>

**VBB**  
Vehicle Barrier Bar

- Impact tested: 7.5 tonne @ 80km/h
- Reliable hydraulic operation
- Adjustable 3-5 seconds lower-raise
- Reinforced horizontal beam
- High impact resistance

**PAS68 TESTED**



Beam fits into a recess when lowered.

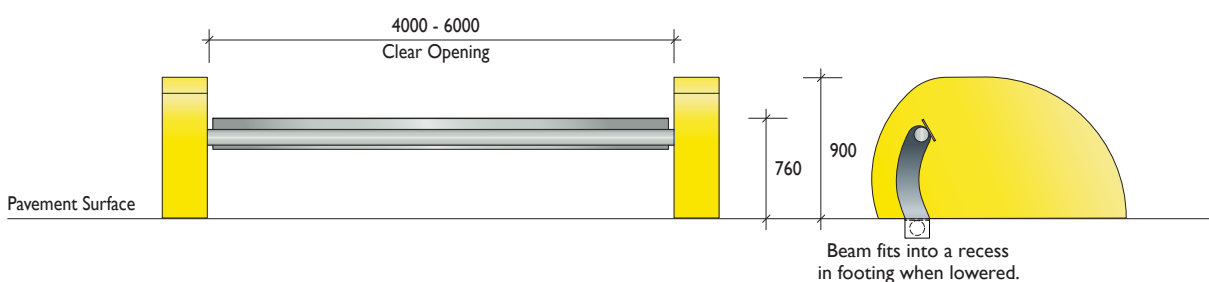

## Product Range > Vehicle Barriers

☎ 1300 780 450

### Barrier-in-a-Box

Designed to provide temporary high security for high-profile events. Aptly named, Barrier-in-a-Box can be transported in a box using a light vehicle and deployed quickly and effectively using existing bollards.

Traffic flow disruption caused by lengthy road closures can be kept to a minimum prior to, and directly after the crucial control period.

Barrier-in-a-Box is a versatile physical barrier that is ideal for where a temporary security solution is required. It relies on high-tech fibre technology and has been successfully tested and has arrested a 7.5 tonne vehicle travelling at 48 km/h.

### Applications

- Official openings and visitations
- Outdoor music and cultural events
- Temporary road closures
- Plaza and open space access control

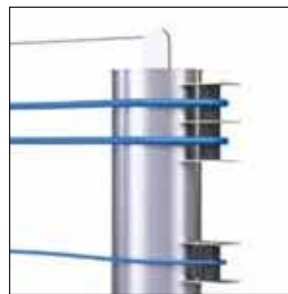

**BIB**

**Barrier-in-a-Box**

**PAS68  
TESTED**

Security Rating  
V7500 (N2) 48/90 : 1.7/0.8

- Impact tested: 7.5 tonne @ 48km/h
- Temporary or permanent installation
- Minimises traffic disruptions
- Uses existing security bollards
- Deployed in 7 minutes
- High impact resistance

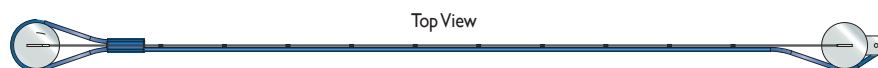
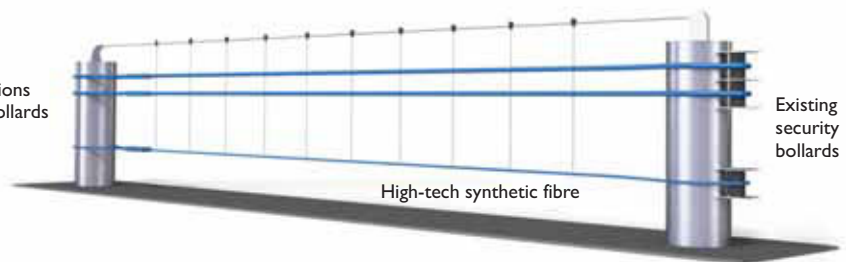

Top View

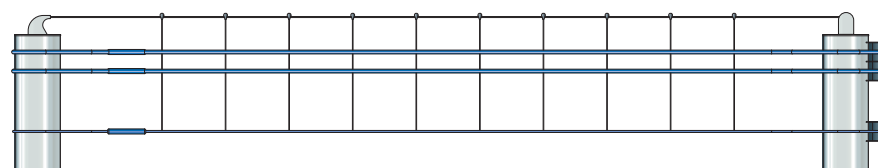

Front View

End View

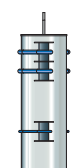

Pavement Surface



# Product Range > Vehicle Barriers

# Barriers

1300 780 450

## RMG50 Retractable Manual

Ideal for sites that are subject to infrequent vehicular traffic

**PAS68  
TESTED**

Security Rating  
V2500 (NIG) 48/90 : 0.0/0.0

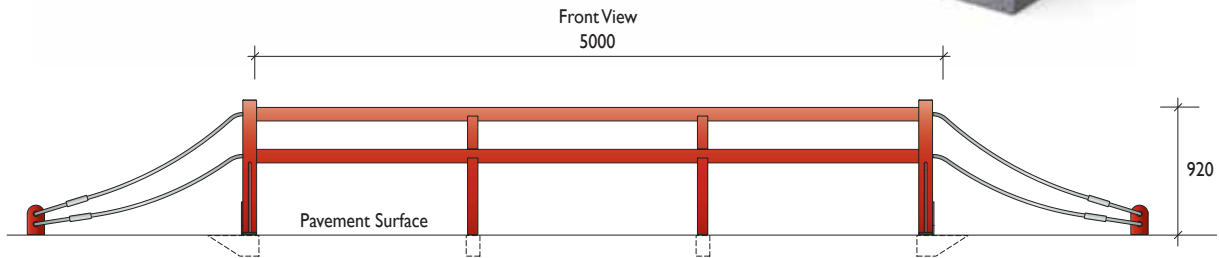

<b>Intro</b>	<b>2</b>
<b>Gates</b>	<b>14</b>
Track	20
Cantilever	30
Swing	40
Bi-fold	46
Boom	52
Options	76
General	82
<b>Barriers</b>	<b>94</b>
Blockers	100
Tyre Spikes	102
Pre-cast	106
Other	111
<b>Pedestrian</b>	<b>114</b>
Turnstiles	114
Gates & Doors	136
<b>Fencing</b>	<b>142</b>
<b>Code Index</b>	<b>153</b>



Product Range > Vehicle Barriers > Road Blockers

☎ 1300 780 450

**RB1414**  
Surface Mount



- Impact rated up to 138kj  
1.5 tonne @ 48km/h  
2 tonne @ 42km/h  
3 tonne @ 35km/h
- Manual or automatic operation
- Hydraulic mitigator option for added protection
- Temporary or permanent installation
- Speed hump in passive mode

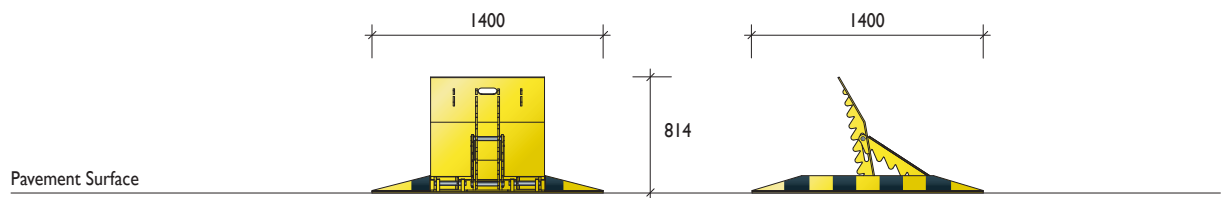

**RB3014**  
Surface Mount



- Impact rated up to 700kj  
3.5 tonne @ 48km/h
- Manual or automatic operation (3 rams)
- Hydraulic mitigator option for added protection
- Temporary or permanent installation
- Designed for rapid deployment
- Prefabricated footings available
- Speed hump in passive mode

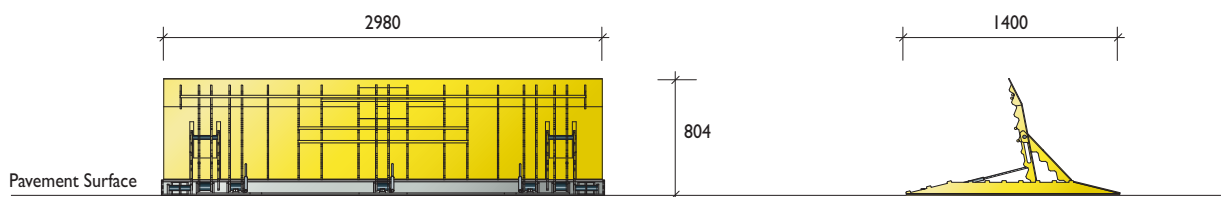

Product Range > Vehicle Barriers > Road Blockers

Barriers

☎ 1300 780 450

**DEF950**  
Shallow Mount

**PAS68  
TESTED**

- Hydraulic operation
- Emergency hand pump during power outages
- Operating speed 6 seconds raise or lower
- Collapsible safety skirts
- PC programmable control system compatible with most access control systems
- Operating temperature range -25°C - 70°C
- Crash tested – 7.75 tonne @ 80km/h

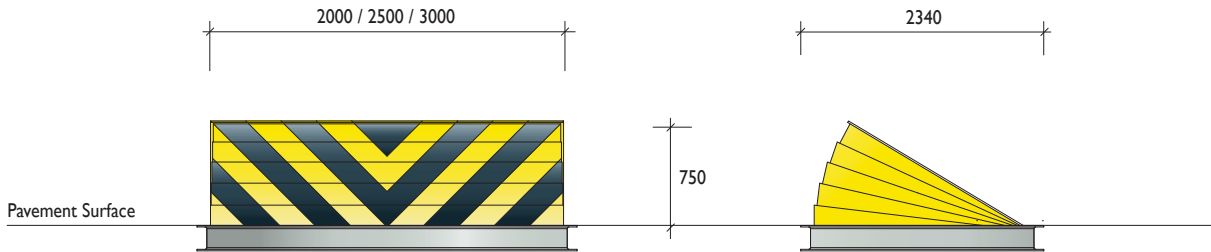

**SW12**  
Shallow Mount

**SECURITY  
K12  
RATED**

- Standard operating speed 3-5 seconds, raise or lower
- Emergency operating available 1-2 seconds, raise or lower
- Crash tested – 7.5 tonne @ 80km/h

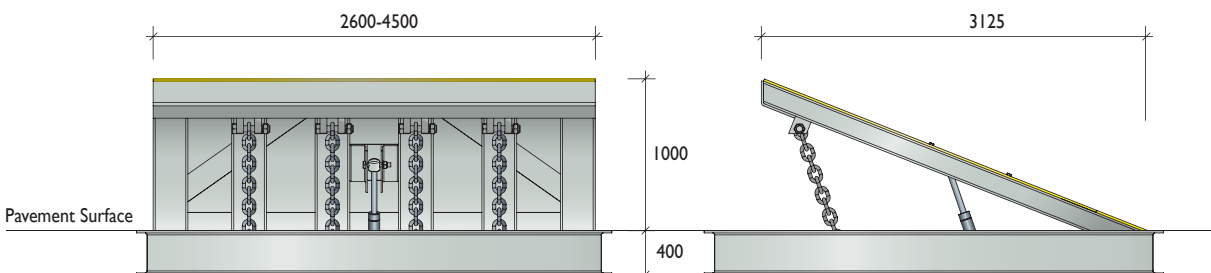

<b>Intro</b>	<b>2</b>
<b>Gates</b>	<b>14</b>
Track	20
Cantilever	30
Swing	40
Bi-fold	46
Boom	52
Options	76
General	82
<b>Barriers</b>	<b>94</b>
Blockers	100
Tyre Spikes	102
Pre-cast	106
Other	111
<b>Pedestrian</b>	<b>114</b>
Turnstiles	114
Gates & Doors	136
<b>Fencing</b>	<b>142</b>
<b>Code Index</b>	<b>153</b>



☎ 1300 780 450



Leda tyre spikes provide security protection for restricted areas against forced and unauthorised entry or exit of motor vehicles. Tyre spikes work by destroying vehicle tyres and immobilising the vehicle.

- Manual
- Automatic

Tyre spikes are available in both manual and automatic models and can be installed as single or multiple units. They are often used as part of a combined perimeter security solution incorporating barriers such as gates, bollards or boom gates to achieve a sluice arrangement forming a vehicle check-point or as part of a vehicle interlocking system.

They are constructed in heavy gauge mild steel, fully welded and hot-dipped galvanised to ensure maximum protection against corrosion.

### Applications

- Airports and shipping ports
- Government buildings
- Industrial areas
- Embassies
- Military complexes
- Power plants
- Car parks
- Distribution depots
- Car rental yards



### Manual Tyre Spikes

Manual tyre spikes allow safe vehicle movement in one authorised direction. They sit in the raised position as a permanent deterrent and prevent vehicles from entering unauthorised areas or in the wrong direction. They are counter-weighted to allow vehicles to cross safely in the correct direction and act as a speed hump to provide traffic calming.



Product Range > Vehicle Barriers > Tyre Spikes

Barriers

☎ 1300 780 450

**Manual TSM10**  
Surface Mount

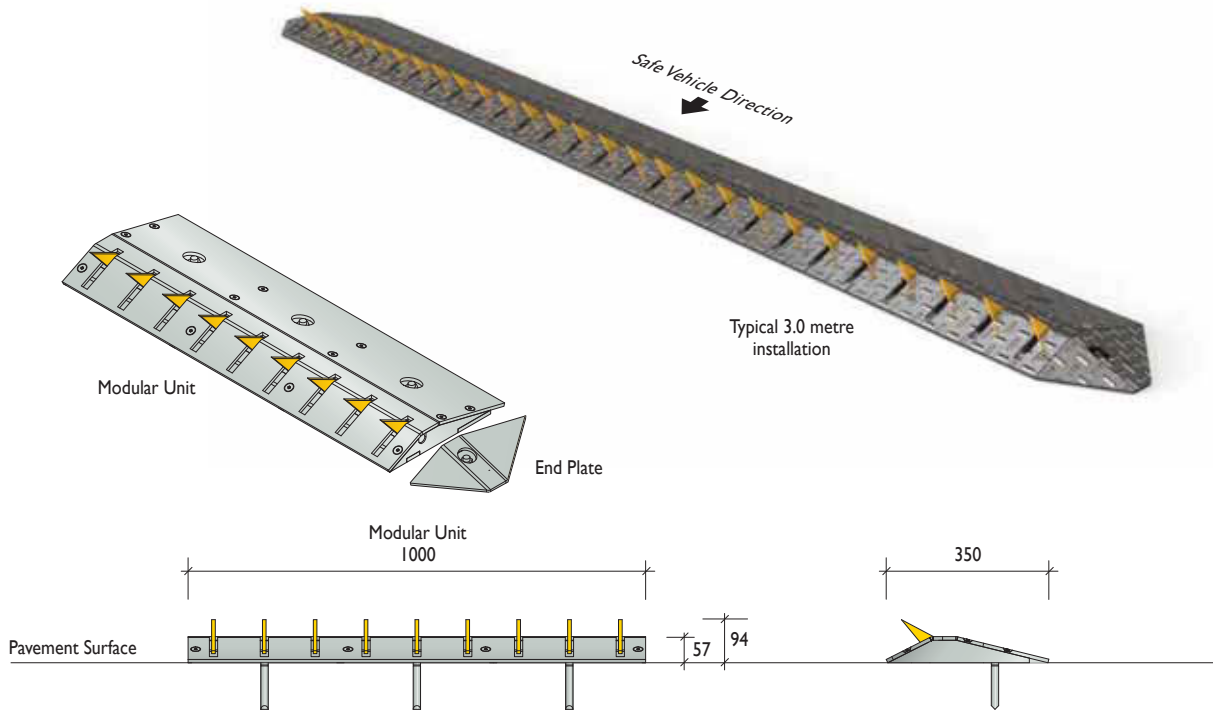

**Manual TSM10IG**  
In Ground

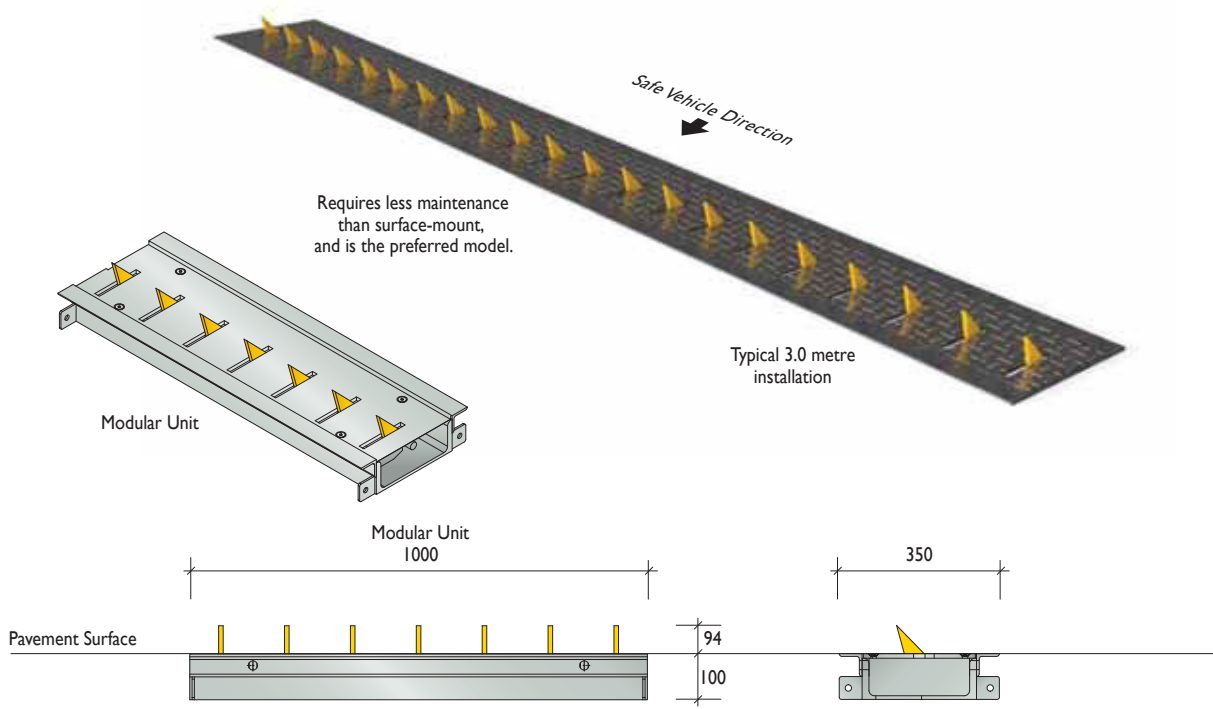

<b>Intro</b>	<b>2</b>
<b>Gates</b>	<b>14</b>
Track	20
Cantilever	30
Swing	40
Bi-fold	46
Boom	52
Options	76
General	82
<b>Barriers</b>	<b>94</b>
Blockers	100
Tyre Spikes	102
Pre-cast	106
Other	111
<b>Pedestrian</b>	<b>114</b>
Turnstiles	114
Gates & Doors	136
<b>Fencing</b>	<b>142</b>
<b>Code Index</b>	<b>153</b>

☎ 1300 780 450



### Automatic Tyre Spikes

Automatic heavy duty tyre spikes have been installed on numerous port exits throughout Australia. They are pneumatically operated and can be raised to their armed position in approximately two seconds. In the unarmed (lowered) position, they are completely inconspicuous and safe to drive over.

Standard model tyre spikes are designed to block standard width driveways. Wider versions may be fabricated as customised units by combining standard units together.

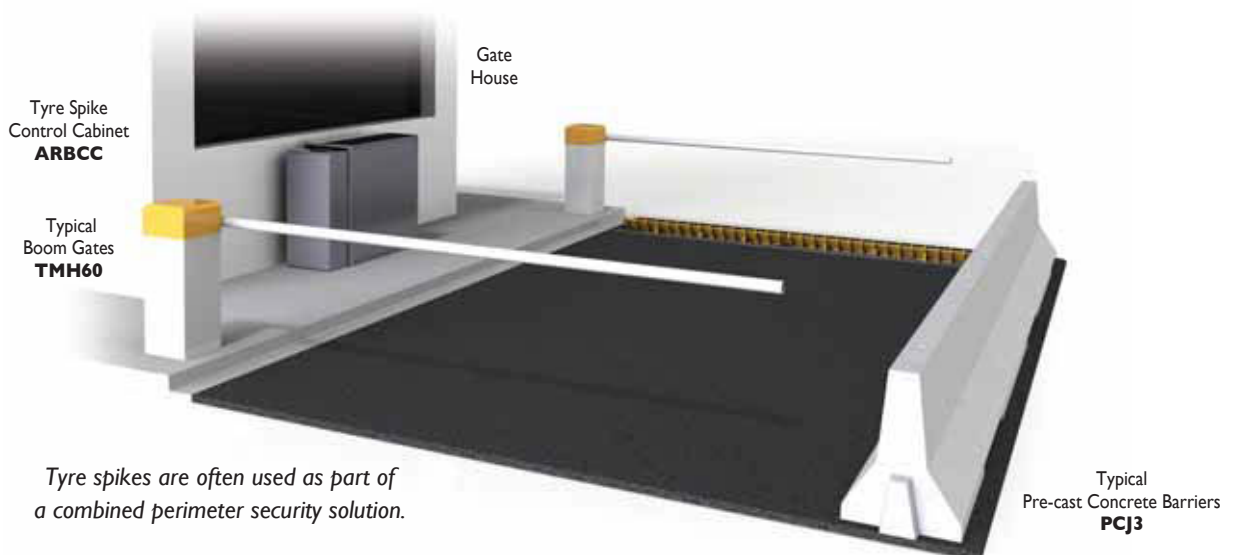

*Tyre spikes are often used as part of a combined perimeter security solution.*



# Product Range > Vehicle Barriers > Tyre Spikes

## Barriers

1300 780 450

**Auto TSA20**  
In Ground

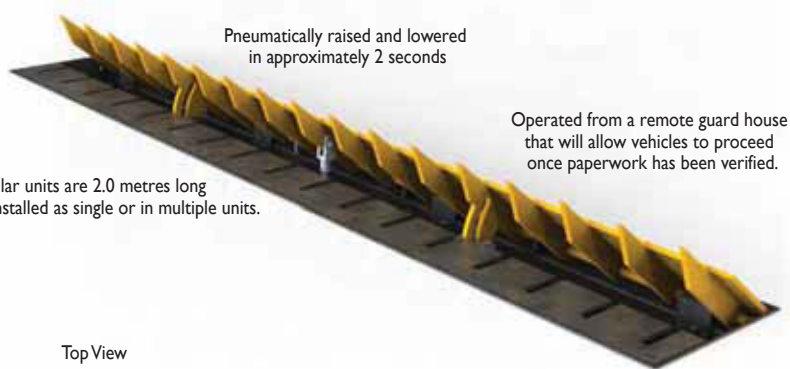

Modular units are 2.0 metres long and can be installed as single or in multiple units.

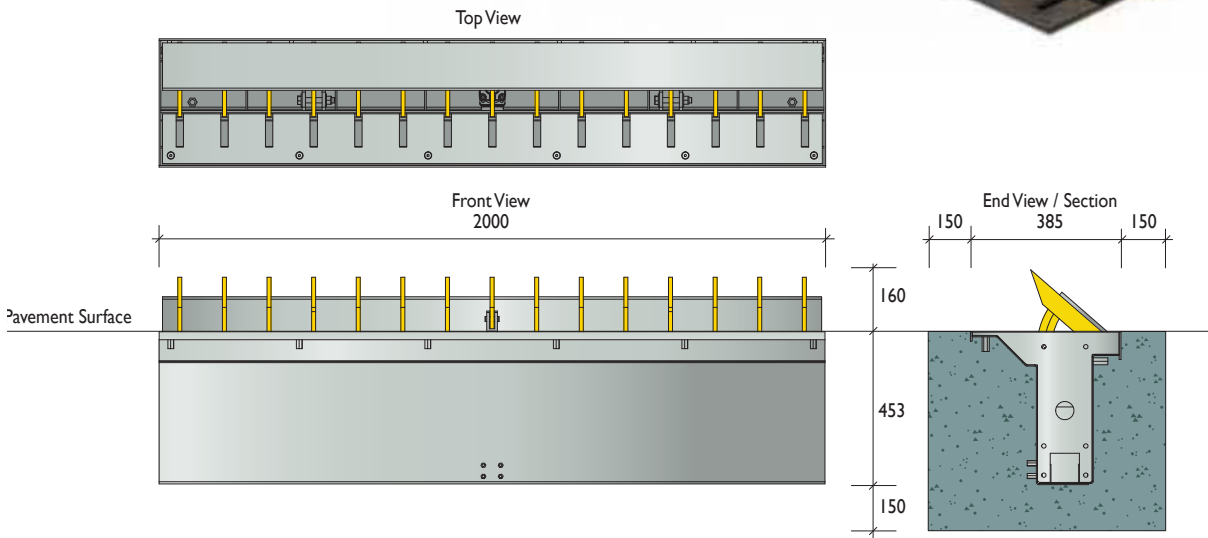

### Typical Configuration

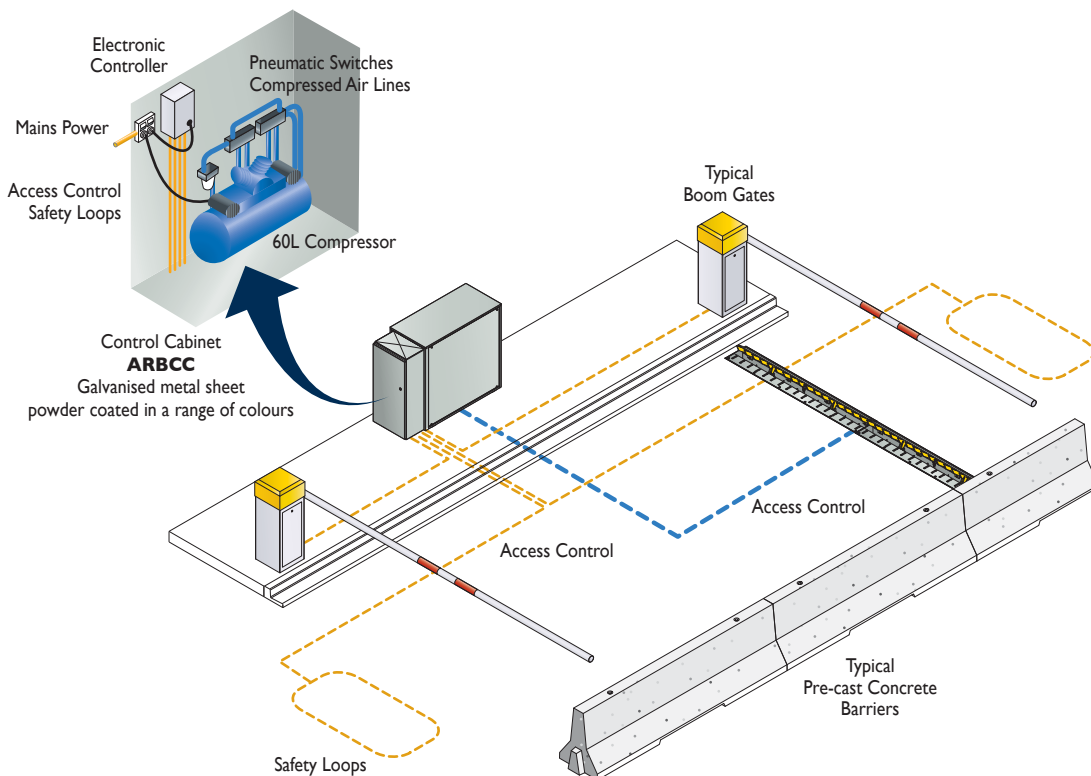

<b>Intro</b>	<b>2</b>
<b>Gates</b>	<b>14</b>
Track	20
Cantilever	30
Swing	40
Bi-fold	46
Boom	52
Options	76
General	82
<b>Barriers</b>	<b>94</b>
Blockers	100
Tyre Spikes	102
Pre-cast	106
Other	111
<b>Pedestrian</b>	<b>114</b>
Turnstiles	114
Gates & Doors	136
<b>Fencing</b>	<b>142</b>
<b>Code Index</b>	<b>153</b>

## Product Range > Vehicle Barriers > Pre-cast Concrete

☎ 1300 780 450

Leda pre-cast concrete barriers can form a critical part to any security solution requiring the need to sustain vehicle impact while maintaining a high degree of aesthetic appeal. Concrete barriers are a formidable visual deterrent and can be designed into various configurations to meet both security and architectural requirements.



Leda concrete barriers are available in a variety of shapes, textures and colours, in 4 main lines:

- Pre-cast Concrete Barriers
- Pre-cast Concrete Planters
- Pre-cast Concrete Logs
- Pre-cast Concrete Vehicle Stops

Manufactured from solid reinforced concrete, the Leda pre-cast range offers temporary and permanent solutions from good-looking planters through to high security barriers.

While impact resistance is achieved through the mass of the concrete barriers, higher impact resistance can be achieved by using Leda's high-strength steel locating pins (Australian Innovative Patent 2006101002) keyed into the pavement. Installation is quick and simple through concrete core drilling.

Concrete barriers also have the added advantage of being cost-effective portable barriers suitable to be used as part of a temporary or permanent security installation solution.

All pre-cast concrete barriers are steel reinforced, and engineered to provide maximum security against impact attacks.

### Applications

- Road and building sites
- Public areas and squares
- Alfresco on-street dining areas
- Government building forecourts
- Defence areas
- Mining sites



☎ 1300 780 450



**Jersey Barriers**

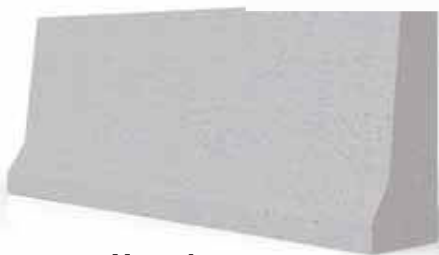

**Hercules Barriers**



**Samson Barriers**



**Rectangular Planters**



**Car & Truck Stops**



**Logs & Cubes**

<b>Intro</b>	<b>2</b>
<b>Gates</b>	<b>14</b>
Track	20
Cantilever	30
Swing	40
Bi-fold	46
Boom	52
Options	76
General	82
<b>Barriers</b>	<b>94</b>
Blockers	100
Tyre Spikes	102
Pre-cast	106
Other	111
<b>Pedestrian</b>	<b>114</b>
Turnstiles	114
Gates & Doors	136
<b>Fencing</b>	<b>142</b>
<b>Code Index</b>	<b>153</b>



☎ 1300 780 450

**Jersey Barriers**

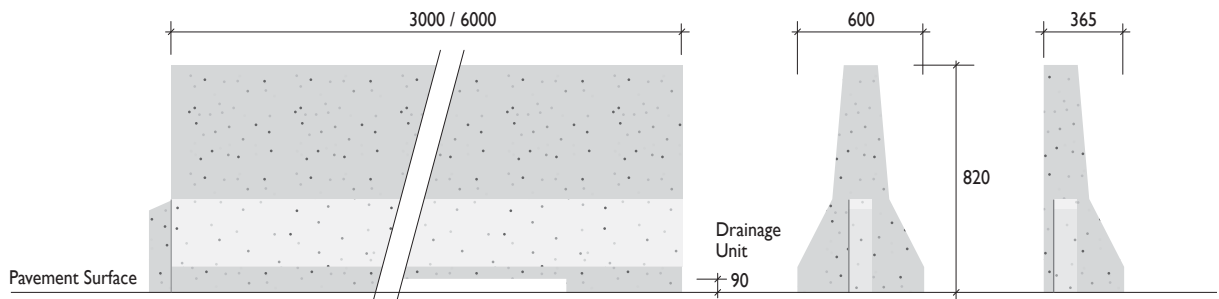
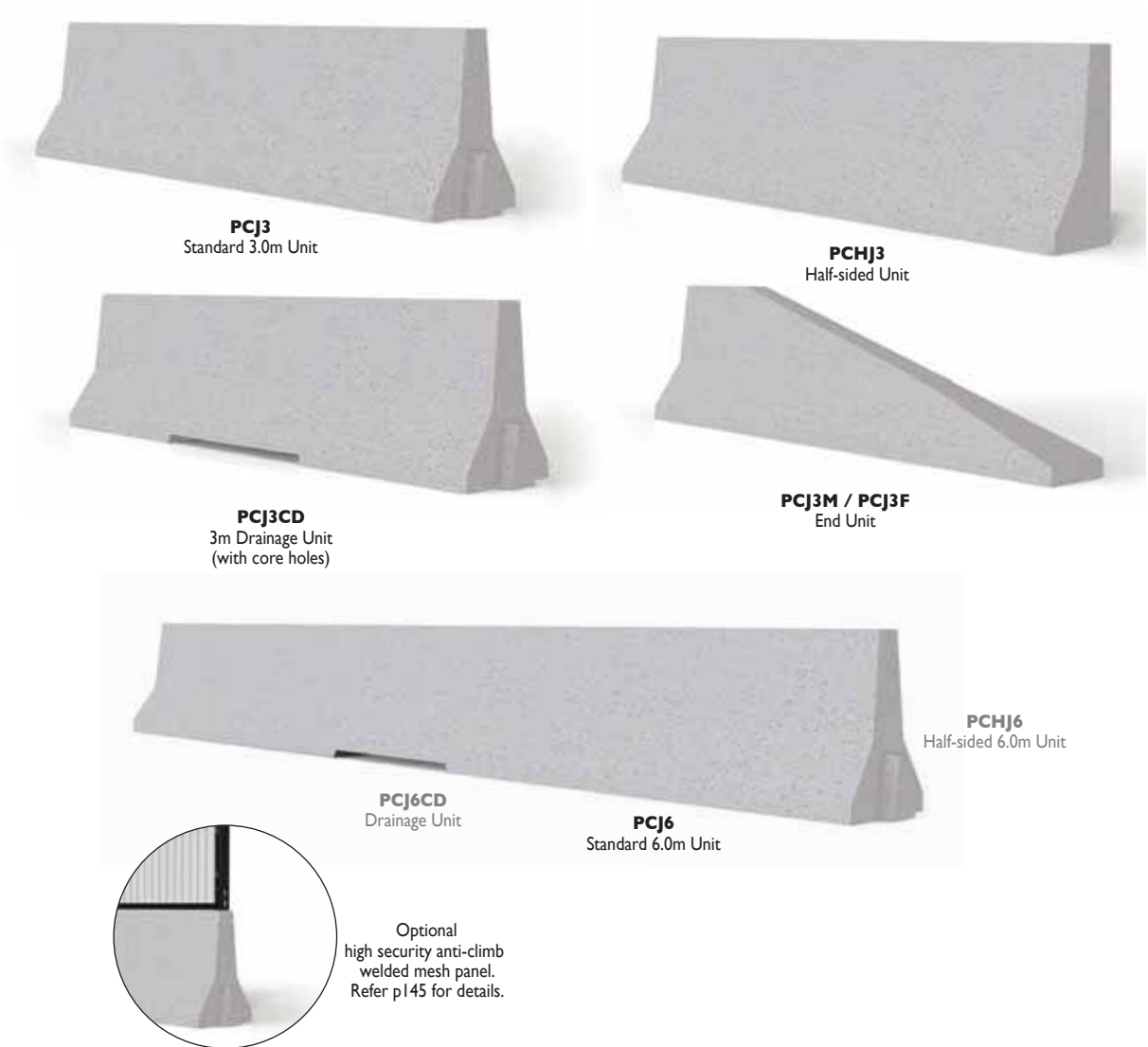

Product code	Type	Length (mm)	Width (mm)	Weight (kg)	Details
<b>PCJ3</b>	Standard Unit	3000	600	2300	
<b>PCHJ3</b>	Half-sided Unit	3000	365	1300	Flat one side
<b>PCJ3CD</b>	Drainage Unit	3000	600	2100	Core holes & 90mm recess
<b>PCJ3M / F</b>	Unit	3000	600	1400	Tapered end, male / female
<b>PCJ6</b>	Standard Unit	6000	600	4600	
<b>PCHJ6</b>	Half-sided Unit	6000	365	2700	Flat one side
<b>PCJ6CD</b>	Drainage Unit	6000	600	4200	Core holes & 90mm recess

☎ 1300 780 450

**Hercules Barrier**

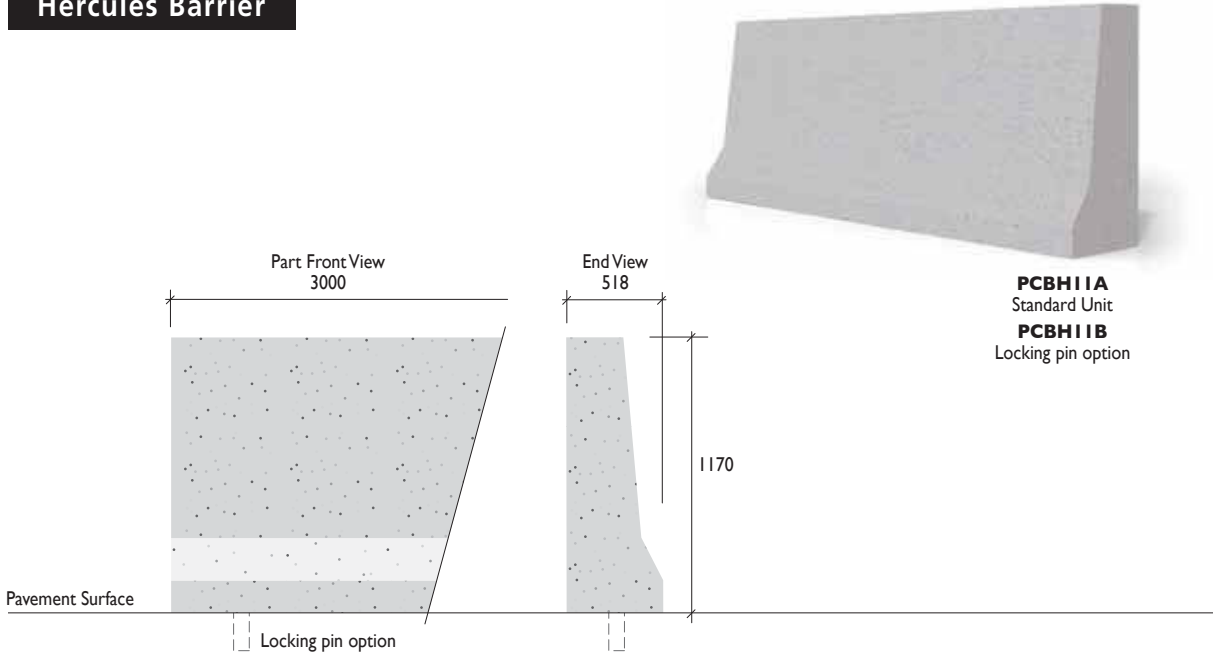

**Intro** 2

**Gates** 14

Track 20

Cantilever 30

Swing 40

Bi-fold 46

Boom 52

Options 76

General 82

**Barriers** 94

Blockers 100

Tyre Spikes 102

Pre-cast 106

Other 111

**Pedestrian** 114

Turnstiles 114

Gates & Doors 136

**Fencing** 142

**Code Index** 153

**Samson Barrier**

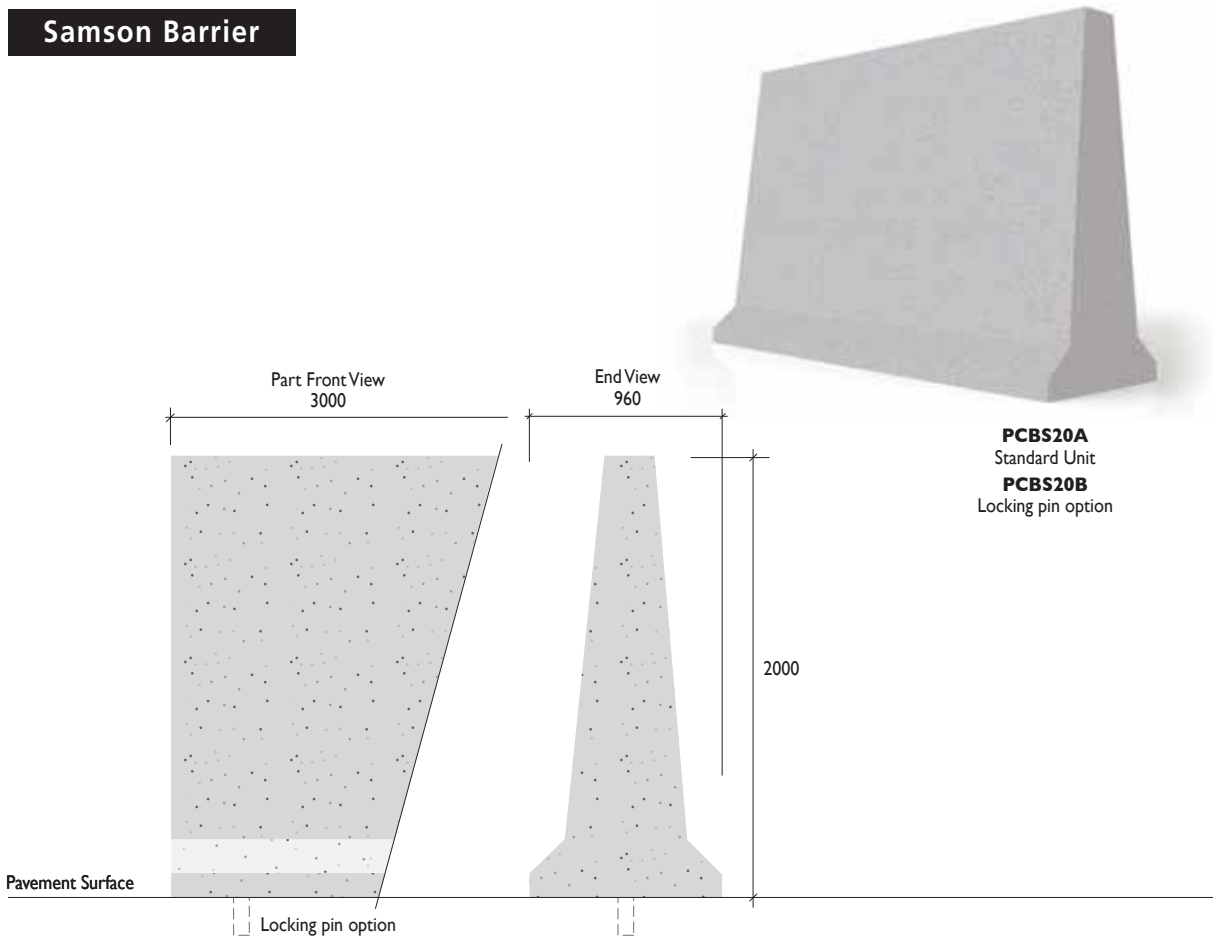

Product code	Type	Length (mm)	Width (mm)	Height	Weight (kg)
<b>PCBH11A</b>	Standard Unit	3000	518	1170	3285
<b>PCBH11B</b>	Locking Pins	3000	518	1170	3285
<b>PCBS20A</b>	Standard Unit	3000	960	2000	7950
<b>PCBS20B</b>	Locking Pins	3000	960	2000	7950

☎ 1300 780 450

**Planters & Logs**



Minimum 30MPa concrete

**Finishes**  
Off-white / grey lightly sandblasted

**Rectangular Planters  
PCB1800A/B**

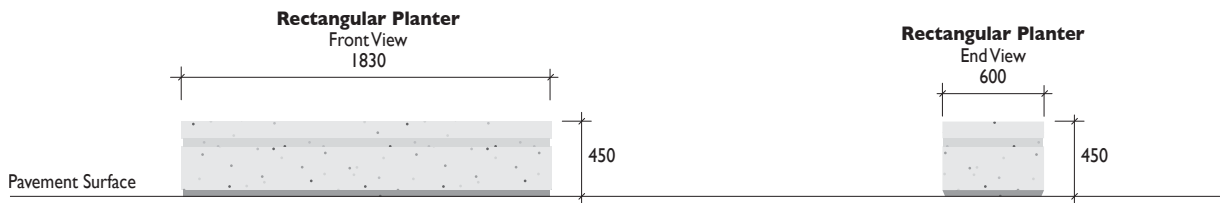

Minimum 30MPa concrete

**Finishes**  
Off-white lightly sandblasted

**Log  
PCL205F**

80NB locking pins  
(Australian Innovative Patent 2006101002)  
keyed to pavement, significantly increases impact resistance



**Cube  
PCL55F**

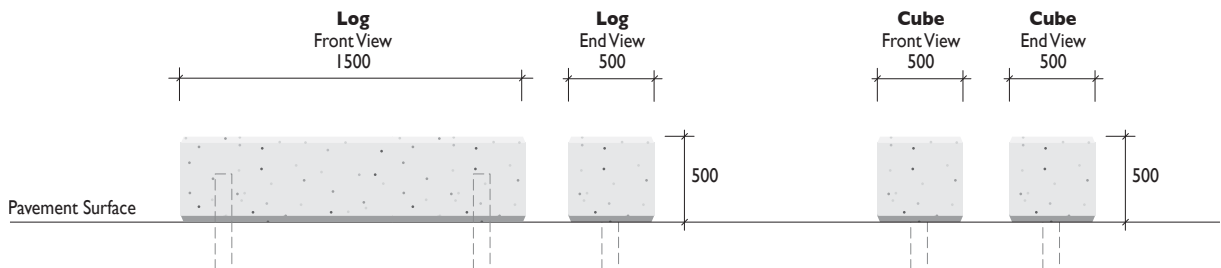

Product code	Type	Length (mm)	Width (mm)	Height	Finish
<b>PCB1800A</b>	Rectangular Planter	1830	600	450	Grey / sand blasted
<b>PCB1800B</b>	Rectangular Planter	1830	600	450	Off-white / sand blasted
<b>PCL205F</b>	Solid Log	2000	500	500	Off-white / sand blasted
<b>PCL55F</b>	Solid Cube	500	500	500	Off-white / sand blasted



1300 780 450

Wheel Stops

**Pre-cast Concrete Car Stops**  
30MPa concrete  
Conforming to AS2890.1 – 2004

WS16

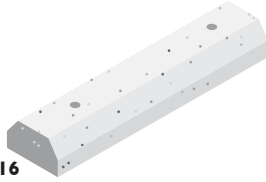

**Truck Stops**

TWS

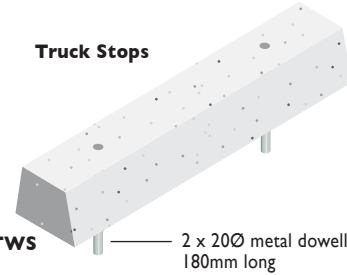

WS20



**100% Recycled Rubber Car Stops**

WSR16

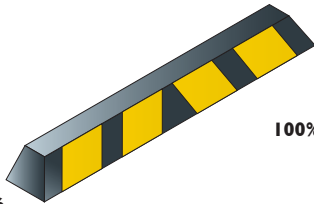

WSR20

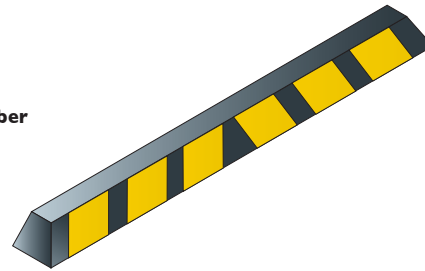

**Mild Steel Speed Hump**

Bolt down

HUMPMS

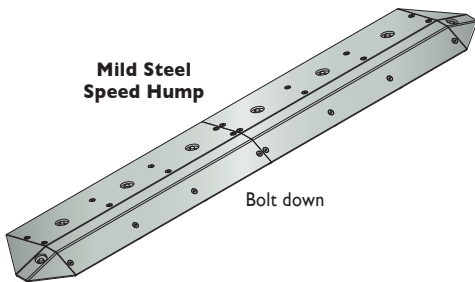

**Asphalt Speed Hump**

120mm height  
for installation on asphalt surfaces

SHUMPASPH

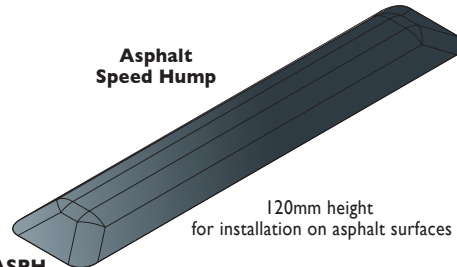

<b>Intro</b>	<b>2</b>
<b>Gates</b>	<b>14</b>
Track	20
Cantilever	30
Swing	40
Bi-fold	46
Boom	52
Options	76
General	82
<b>Barriers</b>	<b>94</b>
Blockers	100
Tyre Spikes	102
Pre-cast	106
Other	111
<b>Pedestrian</b>	<b>114</b>
Turnstiles	114
Gates & Doors	136
<b>Fencing</b>	<b>142</b>
<b>Code Index</b>	<b>153</b>

Product code	Material	Type	Length (mm)	Width (mm)	Height	Weight (kg)
WS16	Pre-cast	Car Stop	1650	190	90	57
WS20		Car Stop	2000	190	90	70
TWS		Truck Stop	1500	200	158	110
WSR16	Rubber	Car Stop	1650	160	100	19
WSR20		Car Stop	2000	160	100	22
HUMPMS	Mild Steel	Speed Hump	1000 modules	350	57	30
SHUMPASPH		Speed Hump	to design	to design	100	n/a

# Product Range > Vehicle Barriers > Other Products

☎ 1300 780 450

## Steel Barriers

### Finish

Hot dipped galvanised or powder coated in a range of colours

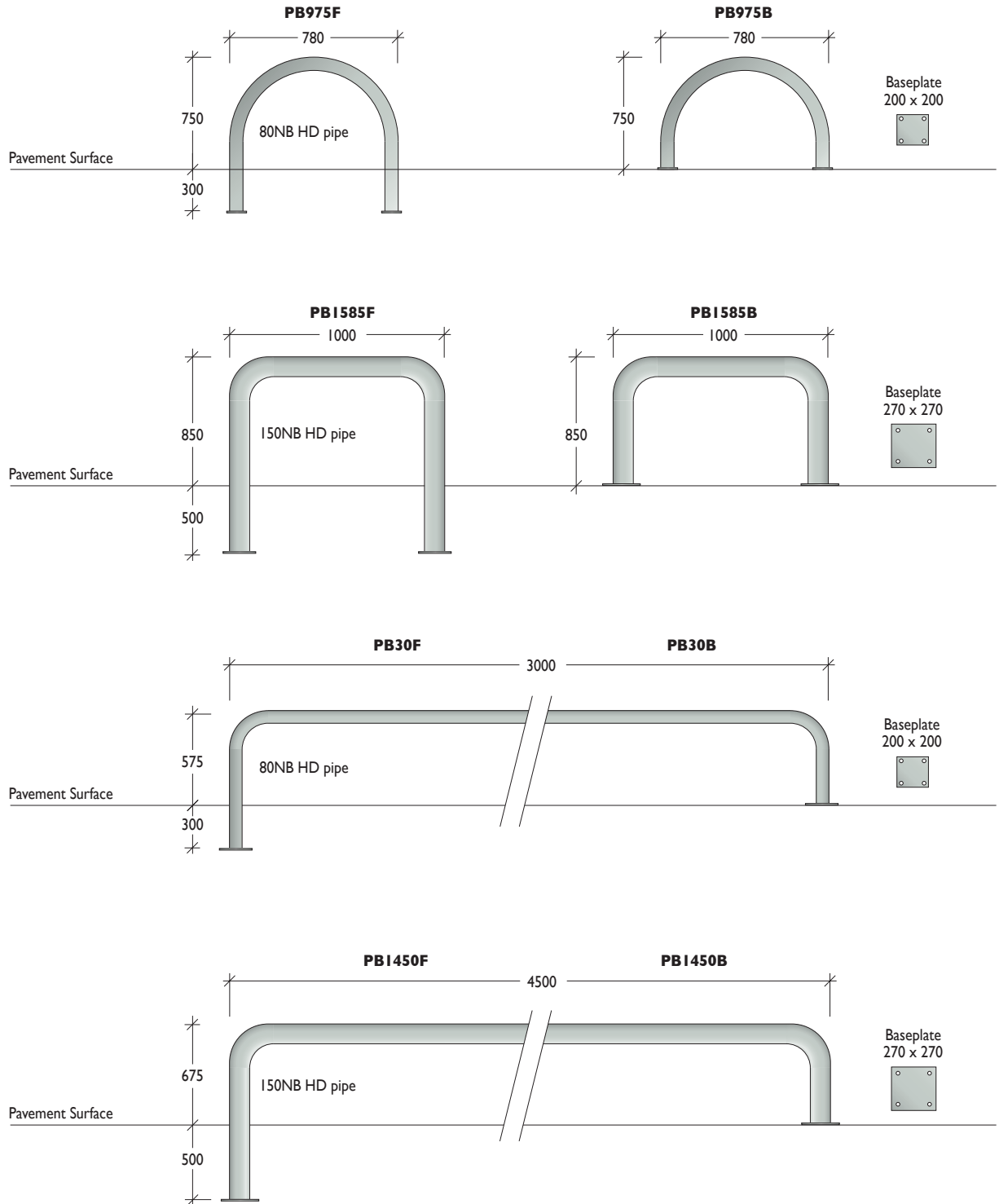

Product code	Type	Length (mm)	Height (mm)	Material
<b>PB975F / B</b>	Fixed Insitu / Baseplate	780	750	80NB (88.9) x 5.9mm HD pipe
<b>PB1585F / B</b>	Fixed Insitu / Baseplate	1000	850	150NB (168.3) x 5.4mm HD pipe
<b>PB30F / B</b>	Fixed Insitu / Baseplate	3000	575	80NB (88.9) x 5.9mm HD pipe
<b>PB1450F / B</b>	Fixed Insitu / Baseplate	4500	675	150NB (168.3) x 5.4mm HD pipe

1300 780 450

**Steel Guards**

**Finish**

Hot dipped galvanised or powder coated in a range of colours

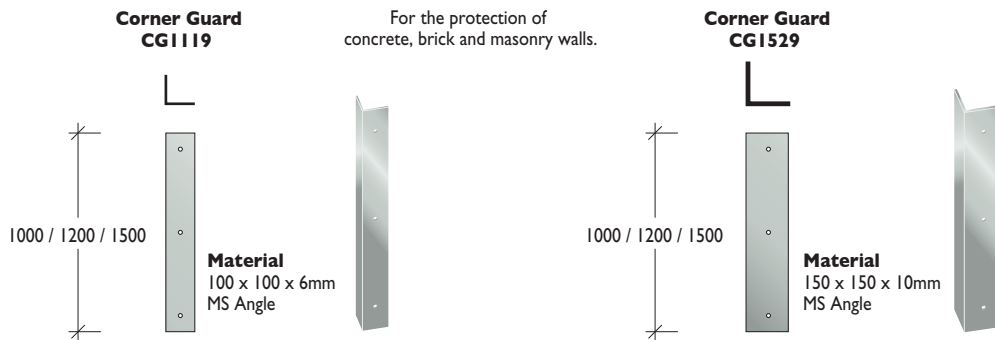
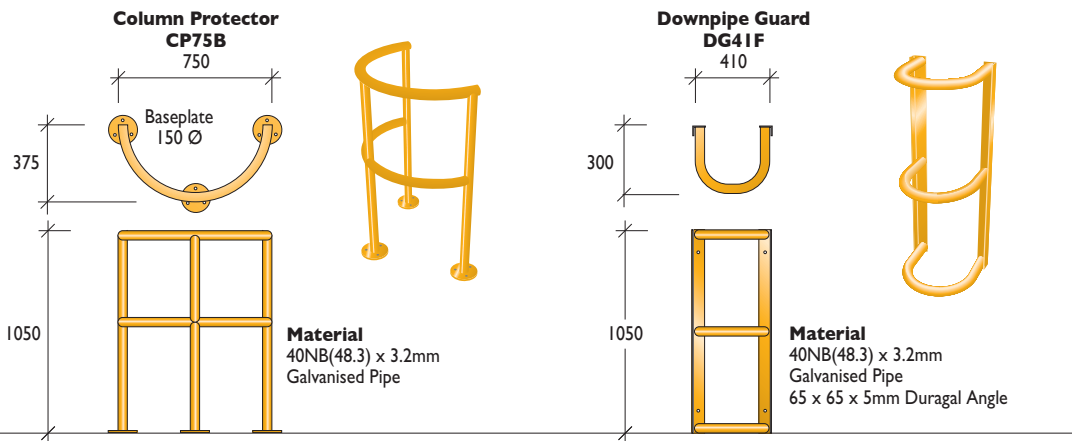
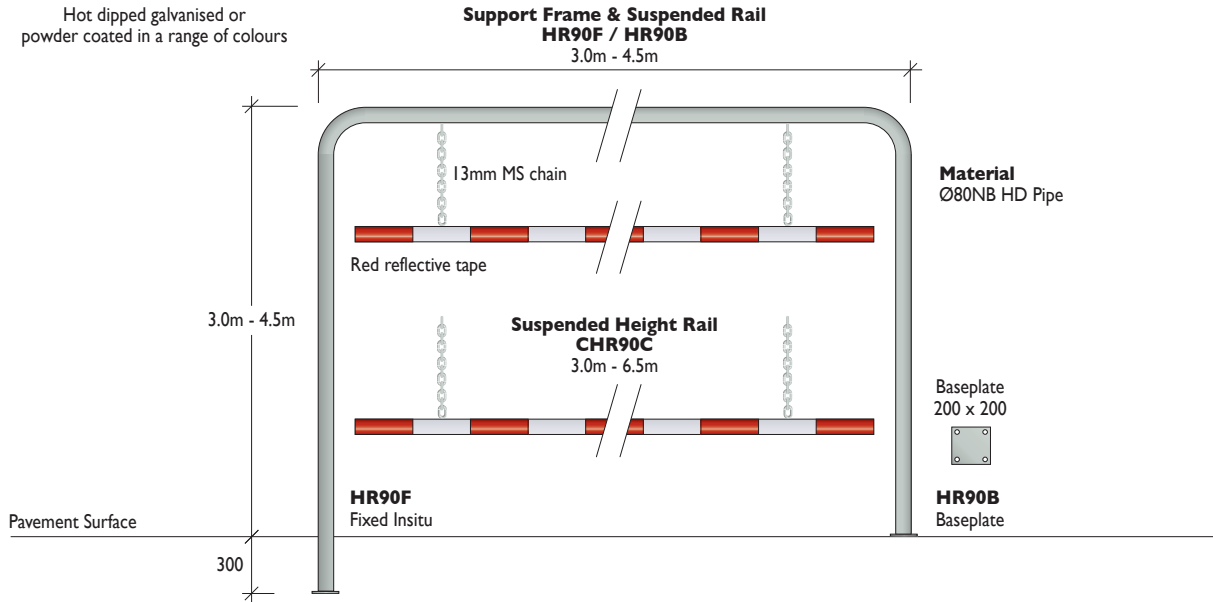

<b>Intro</b>	<b>2</b>
<b>Gates</b>	<b>14</b>
Track	20
Cantilever	30
Swing	40
Bi-fold	46
Boom	52
Options	76
General	82
<b>Barriers</b>	<b>94</b>
Blockers	100
Tyre Spikes	102
Pre-cast	106
Other	111
<b>Pedestrian</b>	<b>114</b>
Turnstiles	114
Gates & Doors	136
<b>Fencing</b>	<b>142</b>
<b>Code Index</b>	<b>153</b>

Product code	Type	Width	Height (mm)	Material
<b>HR90F / B</b>	Suspended Height Rail & Frame	3.0m - 4.5m	3.0m - 4.5m	80NB (88.9) x 5.9mm HD pipe
<b>CHR90C</b>	Suspended Height Rail	3.0m - 6.5m	n/a	80NB (88.9) x 5.9mm HD pipe
<b>CP75B</b>	Column Protector	750 x 375mm	1050mm	40NB (48.3) x 3.2mm HD pipe
<b>DG41F</b>	Downpipe Guard	410 x 300mm	1050mm	40NB (48.3) x 3.2mm HD pipe
<b>CG1119</b>	Corner Guard	100 x 100mm	1000/1200/1500mm	100 x 100 x 6mm MS angle
<b>CG1529</b>	Corner Guard	150 x 150mm	1000/1200/1500mm	150 x 150 x 10mm MS angle



## Product Range > Pedestrian Access > Turnstiles

☎ 1300 780 450

### Full Height Turnstiles

Leda turnstiles have been part of entrance and exit control solutions of major corporations, government bodies and high security organisations' security systems for many years.

Leda pedestrian turnstiles offer designs manufactured from a broad range of materials suitable for use in varying applications across different security levels. The range includes standard full-height turnstiles with simple-to-use functions, to customised turnstiles fitted out with safety or intruder-resistant glass panels and secured by biometric access control systems. Leda turnstiles present a very high operating reliability, making them suitable to be used in areas with high pedestrian traffic while maintaining the need for access control.

They can be supplied in either fail-safe or fail-secure options, with or without battery back-up and can be interfaced with the building's fire alarm panels. They are also designed to allow integration with all common access control systems.

Available in stainless steel (grade 304 or 316) galvanised or electrostatically powder coated in a range of colours. All stainless steel surfaces are finished to a class 4 satin finish.

### Applications

- Industrial complexes
- Warehousing and distribution facilities
- Offices and government buildings
- Low-medium security sections at power plants
- Retail outlets
- Schools, gymnasiums, car parks
- Stadiums and sporting venues
- Ports and wharves
- Mining and refinery plants
- Building sites

Importantly, with branches across Australia, Leda's service technicians are never far away. Leda also offers a range of preventative maintenance contracts (PMC) designed to keep your turnstiles in prime operating condition.

> Refer to p93 for more information on service and maintenance programs.



☎ 1300 780 450



**900mm Rotor Arm  
Bar or Hoop**

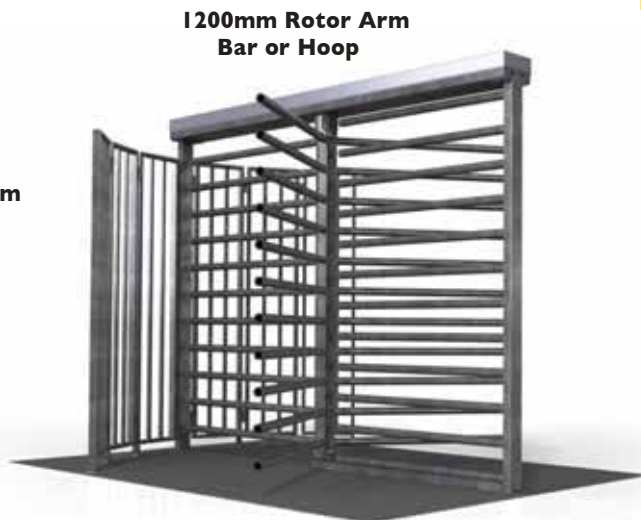

**1200mm Rotor Arm  
Bar or Hoop**



**Polycarbonate**



**High Security**



**Double  
900mm Rotor Arm  
Bar or Hoop**



**High Security  
Double Turnstile with Pedestrian Gate  
Bar or Hoop**



**Roof Options**

<b>Intro</b>	<b>2</b>
<b>Gates</b>	<b>14</b>
Track	20
Cantilever	30
Swing	40
Bi-fold	46
Boom	52
Options	76
General	82
<b>Barriers</b>	<b>94</b>
Blockers	100
Tyre Spikes	102
Pre-cast	106
Other	111
<b>Pedestrian</b>	<b>114</b>
Turnstiles	114
Gates & Doors	136
<b>Fencing</b>	<b>142</b>
<b>Code Index</b>	<b>153</b>

Product Range > Pedestrian Access > Turnstiles

☎ 1300 780 450

**TFB1120**  
900mm Bar

3 arm (120°) rotor  
900mm long



Concrete base  
1800 x 1800 x 100mm deep

**Most Popular Model**

**Finish**

TFB1120 Hot dipped gal steel  
STFB1120 Stainless steel  
(grade 304 or 316)

**Features**

Durable turning head, low noise  
Optional card reader head (300 x 300) can be mounted on turnstile or on separate card reader bollard.  
Optional solar power.  
(Refer accessories p127)

**TFB1120C**  
Cyclone Rated



**CYCLONE RATED**

**CYCLONE RATED**

Engineered footing details and specifications are provided after order has been placed.

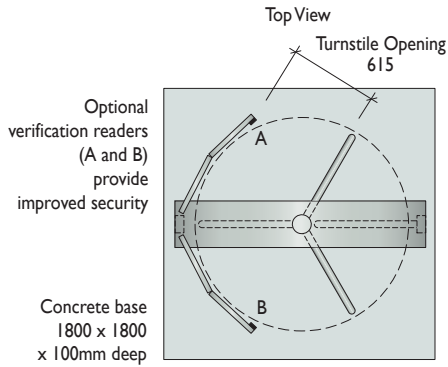

**SAVE ON FREIGHT**

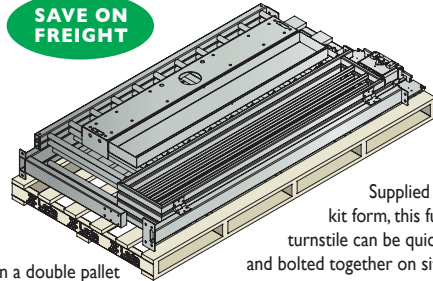

Fits on a double pallet

Supplied in 'knockdown' kit form, this full height turnstile can be quickly assembled and bolted together on site.

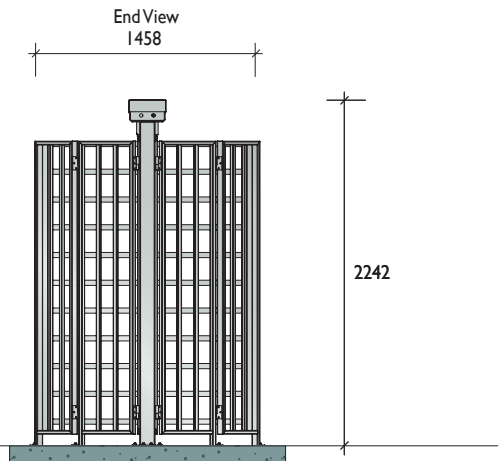

Leda full height turnstiles integrate with other access control systems and cater for a flow of up to 20 people per minute. Controllers can be configured to provide a range of functions (entry only / exit only / entry and exit). Recommended minimum for all concrete footings, 30MPa.



1300 780 450

**TFB2120**  
1200mm Bar



**Finish**  
TFB2120 Hot dipped galvanised steel  
STFB2120 Stainless steel (grade 304 or 316)

**Features**  
Durable turning head, low noise  
Optional card reader head (300 x 300) can be mounted on turnstile or on separate card reader bollard.  
Optional solar power. (Refer accessories p127)

3 arm (120°) rotor  
1200mm long

Concrete base  
100mm deep

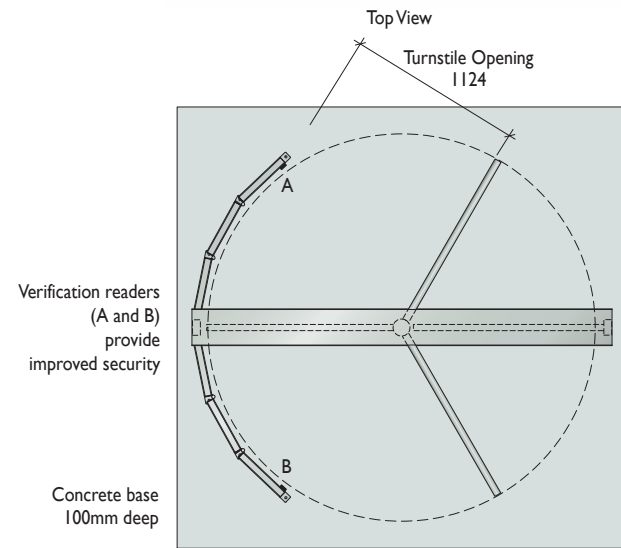

**SAVE ON FREIGHT**

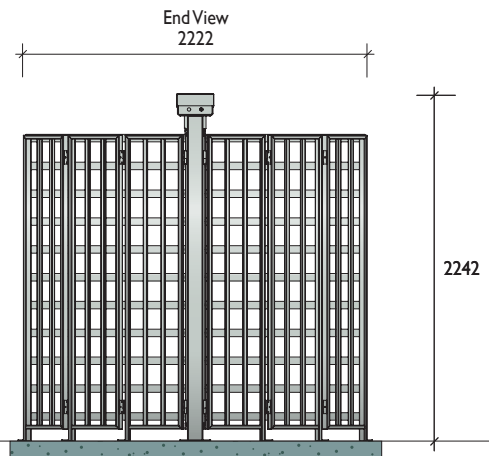
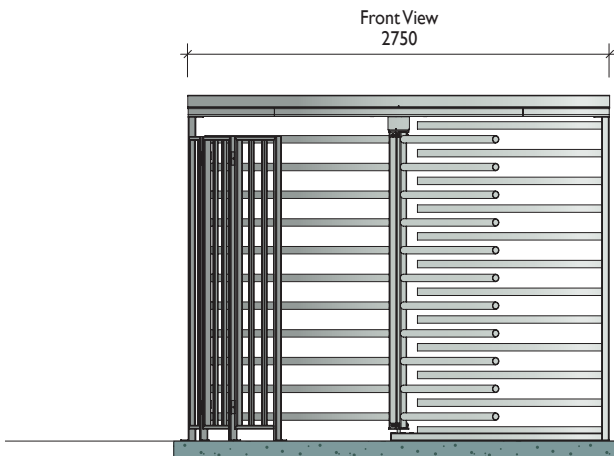
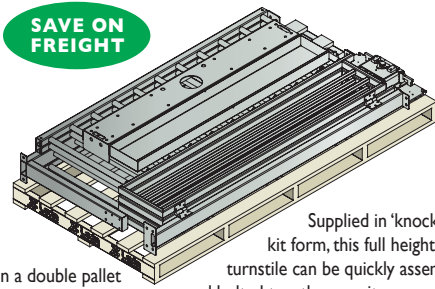

<b>Intro</b>	<b>2</b>
<b>Gates</b>	<b>14</b>
Track	20
Cantilever	30
Swing	40
Bi-fold	46
Boom	52
Options	76
General	82
<b>Barriers</b>	<b>94</b>
Blockers	100
Tyre Spikes	102
Pre-cast	106
Other	111
<b>Pedestrian</b>	<b>114</b>
Turnstiles	114
Gates & Doors	136
<b>Fencing</b>	<b>142</b>
<b>Code Index</b>	<b>153</b>

Leda full height turnstiles integrate with other access control systems and cater for a flow of up to 20 people per minute. Controllers can be configured to provide a range of functions (entry only / exit only / entry and exit). Recommended minimum for all concrete footings, 30MPa.

# Product Range > Pedestrian Access > Turnstiles

☎ 1300 780 450

**RTFB1120**  
900mm Bar  
Relocatable

Designed for easy placement and removal  
at mining sites or building projects

Lifting lugs



**Finish**

Hot dipped galvanised steel

**Features**

3 arm (120°) rotor

Chequerplate base

Lifting lugs for ease of transport and installation

Available either fully assembled or in kit form

Chequerplate base  
2920 x 1600

Top View

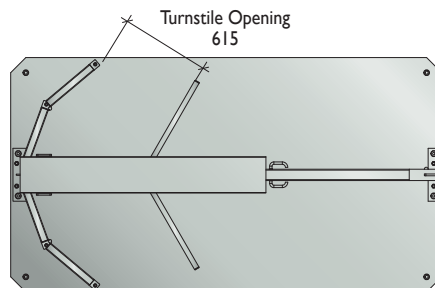

Front View  
2920

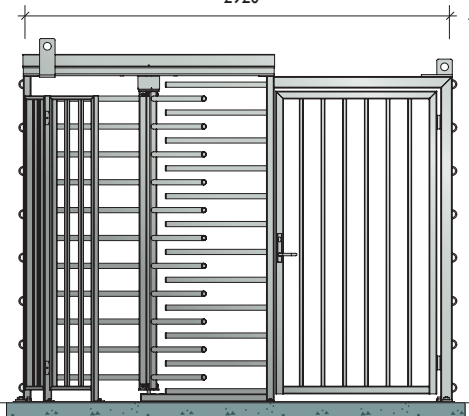

End View  
1600

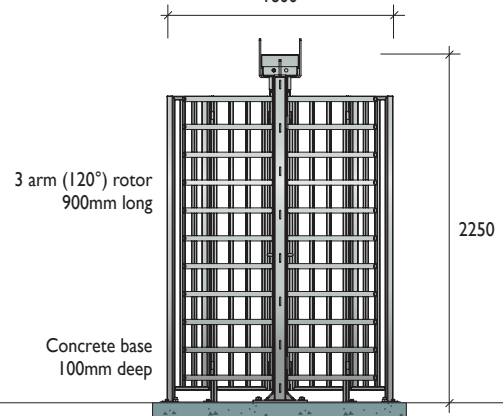

Leda full height turnstiles integrate with other access control systems and cater for a flow of up to 20 people per minute. Controllers can be configured to provide a range of functions (entry only / exit only / entry and exit). Recommended minimum for all concrete footings, 30MPa.

☎ 1300 780 450

**TFBD1120**  
 900mm  
 Double Bar



**Finish**  
 TFBD1120 Hot dipped galvanised steel  
 STFBD1120 Stainless steel (grade 304 or 316)

**Features**  
 3 arm (120°) rotors  
 900mm long  
 Durable turning head, low noise

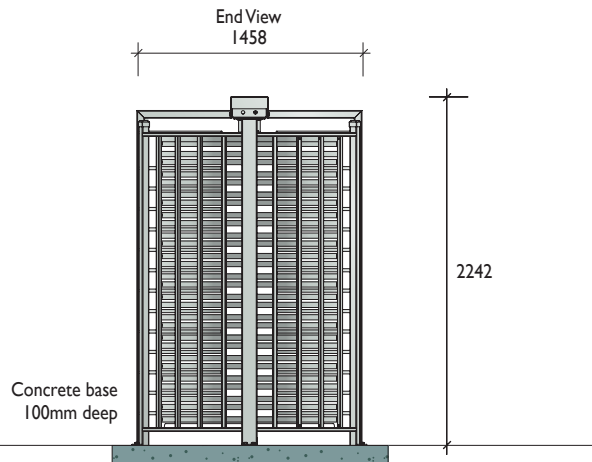
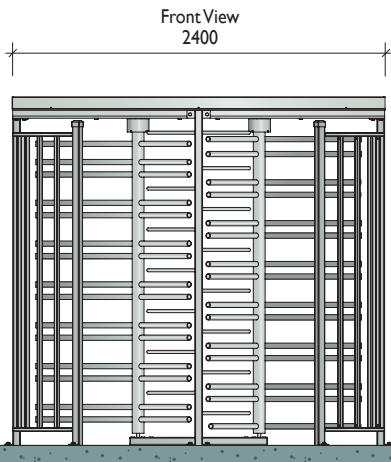
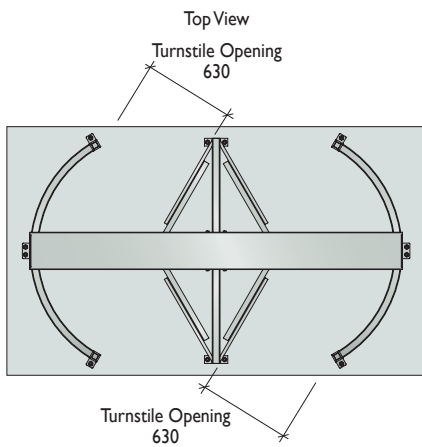

<b>Intro</b>	<b>2</b>
<b>Gates</b>	<b>14</b>
Track	20
Cantilever	30
Swing	40
Bi-fold	46
Boom	52
Options	76
General	82
<b>Barriers</b>	<b>94</b>
Blockers	100
Tyre Spikes	102
Pre-cast	106
Other	111
<b>Pedestrian</b>	<b>114</b>
Turnstiles	114
Gates & Doors	136
<b>Fencing</b>	<b>142</b>
<b>Code Index</b>	<b>153</b>

Leda full height turnstiles integrate with other access control systems and cater for a flow of up to 20 people per minute. Controllers can be configured to provide a range of functions (entry only / exit only / entry and exit). Recommended minimum for all concrete footings, 30MPa.



Product Range > Pedestrian Access > Turnstiles

☎ 1300 780 450

**BTFB1120**  
 900mm Bar  
 Bicycle Entry

Single Turnstile  
 with Bicycle Entry

Access control for cyclists has long been ignored but now, Leda's engineers have designed an electronically operated swing gate for the bicycle which is triggered when the cyclist moves through the turnstile.



**Finish**  
 BTFB1120 Hot dipped galvanised steel  
 SBTFB1120 Stainless steel (grade 304 or 316)

Top View

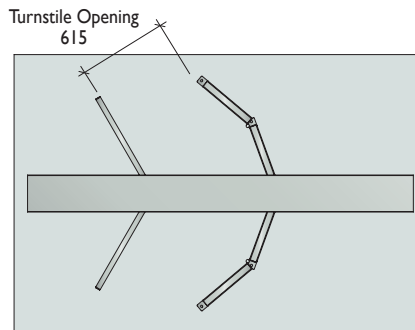

Front View

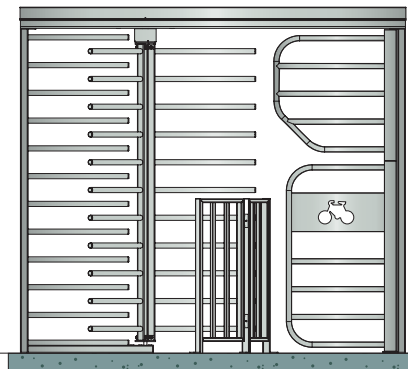

End View



3 arm (120°) rotor  
 900mm long

Concrete base  
 100mm deep

2242

Leda full height turnstiles integrate with other access control systems and cater for a flow of up to 20 people per minute. Controllers can be configured to provide a range of functions (entry only / exit only / entry and exit). Recommended minimum for all concrete footings, 30MPa.

1300 780 450

**TFL1120**  
900mm Looped Bar

Single Turnstile  
**TFL1120**



Double Turnstile  
**TFLD1120**



**Finish**

- TFL1120 Hot dipped galvanised steel
- TFLD1120 Hot dipped galvanised steel
- STFL1120 Stainless steel (grade 304 or 316)
- STFLD1120 Stainless steel (grade 304 or 316)

**TFL1120**  
Top View

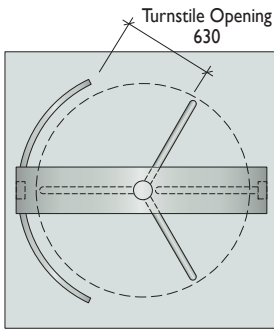

**TFLD1120**  
Top View

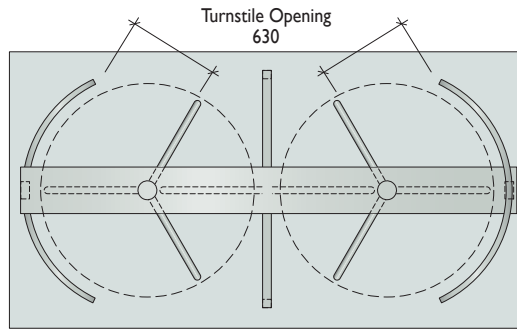

Front View  
1620

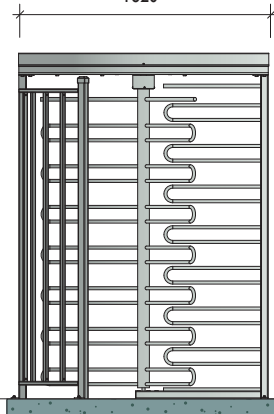

Front View  
2400

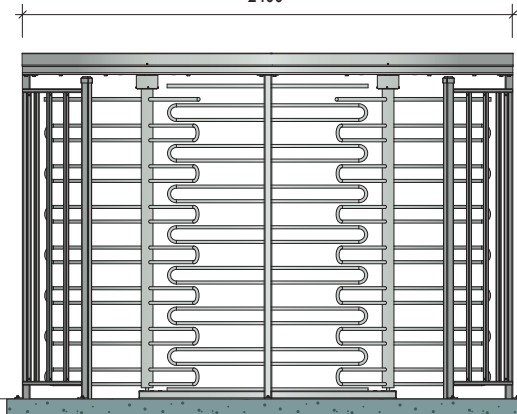

2244

<b>Intro</b>	<b>2</b>
<b>Gates</b>	<b>14</b>
Track	20
Cantilever	30
Swing	40
Bi-fold	46
Boom	52
Options	76
General	82
<b>Barriers</b>	<b>94</b>
Blockers	100
Tyre Spikes	102
Pre-cast	106
Other	111
<b>Pedestrian</b>	<b>114</b>
Turnstiles	114
Gates & Doors	136
<b>Fencing</b>	<b>142</b>
<b>Code Index</b>	<b>153</b>

Leda full height turnstiles integrate with other access control systems and cater for a flow of up to 20 people per minute. Controllers can be configured to provide a range of functions (entry only / exit only / entry and exit). Recommended minimum for all concrete footings, 30MPa.

Product Range > Pedestrian Access > Turnstiles

☎ 1300 780 450

**TFBDP1120**  
900mm Bar  
Pedestrian Gate

Double Turnstile  
with Pedestrian Gate  
Also available in looped bar  
TFLDP1120

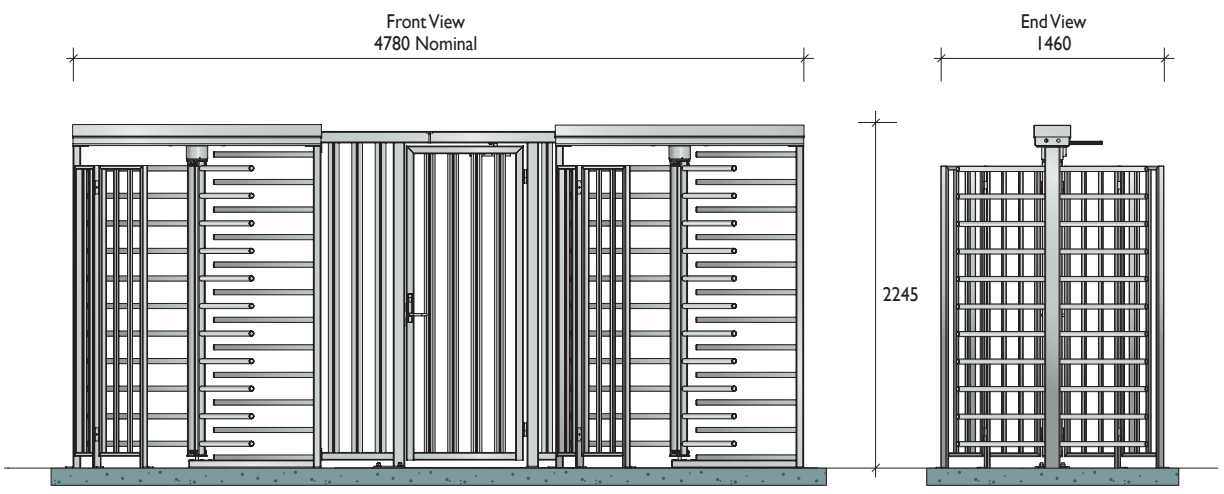
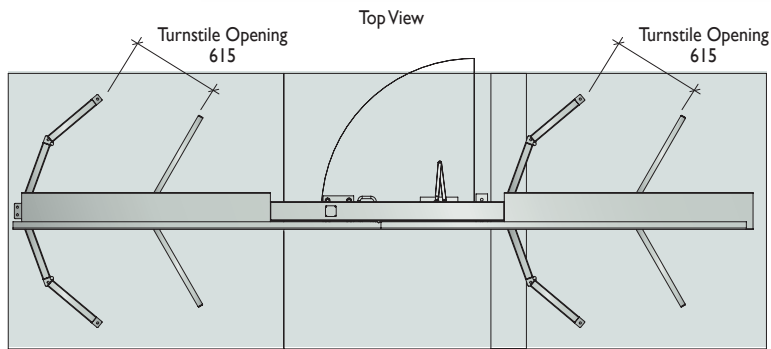

Leda full height turnstiles integrate with other access control systems and cater for a flow of up to 20 people per minute. Controllers can be configured to provide a range of functions (entry only / exit only / entry and exit). Recommended minimum for all concrete footings, 30MPa.



1300 780 450

**STFBDP1120**  
 Double Security  
 Pedestrian Gate

Double Security Turnstile  
 with Pedestrian Gate  
 Also available in looped bar  
 STFLDP1120

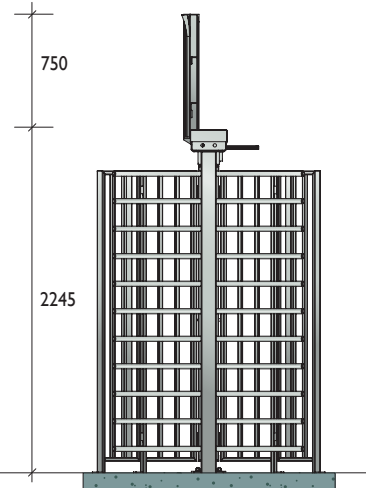
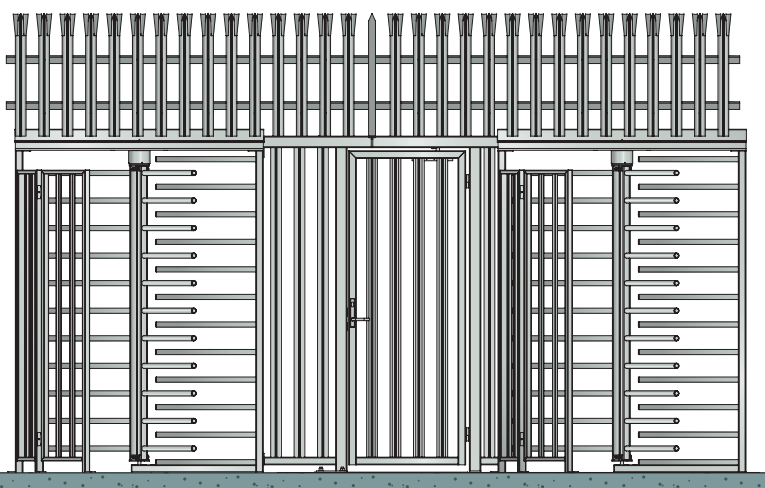
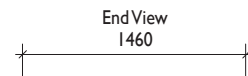
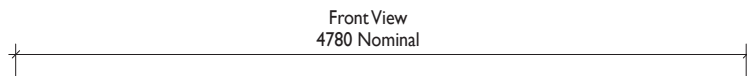
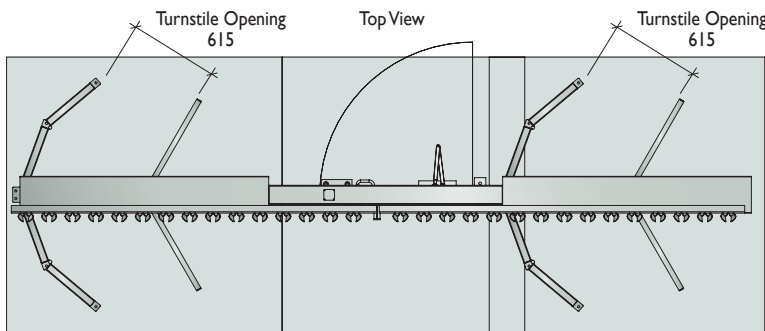

<b>Intro</b>	<b>2</b>
<b>Gates</b>	<b>14</b>
Track	20
Cantilever	30
Swing	40
Bi-fold	46
Boom	52
Options	76
General	82
<b>Barriers</b>	<b>94</b>
Blockers	100
Tyre Spikes	102
Pre-cast	106
Other	111
<b>Pedestrian</b>	<b>114</b>
Turnstiles	114
Gates & Doors	136
<b>Fencing</b>	<b>142</b>
<b>Code Index</b>	<b>153</b>

Leda full height turnstiles integrate with other access control systems and cater for a flow of up to 20 people per minute. Controllers can be configured to provide a range of functions (entry only / exit only / entry and exit). Recommended minimum for all concrete footings, 30MPa.

## Product Range > Pedestrian Access > Turnstiles

☎ 1300 780 450

**D970**

**High Security**

This Leda / Broughton design has been installed in multiple high security locations around the world.



**Security**

4 arm (90°) solid steel plate rotator  
Tested to the equivalent of LPS1175 – 5.2  
Tool Category 'C' Standard  
Resistant to a concerted 15 minute assault

**Finish**

Hot dipped galvanised steel

**Features**

Security-locked housing  
Secure fail safe  
Concealed reinforcement plates prevent drilling

Top View

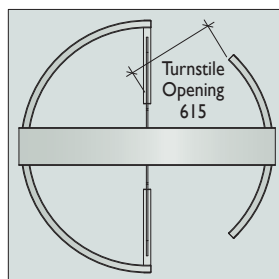

Front View

1350

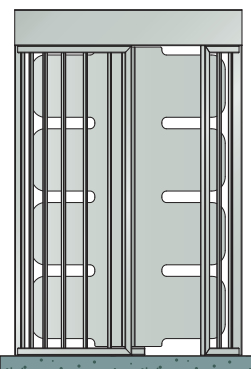

End View

1350

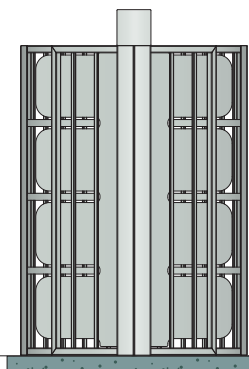

2250

Leda full height turnstiles integrate with other access control systems and cater for a flow of up to 20 people per minute. Controllers can be configured to provide a range of functions (entry only / exit only / entry and exit). Recommended minimum for all concrete footings, 30MPa.

☎ 1300 780 450

**STF2R / 3S**  
Polycarbonate

Aesthetically attractive  
with stainless steel and polycarbonate surfaces

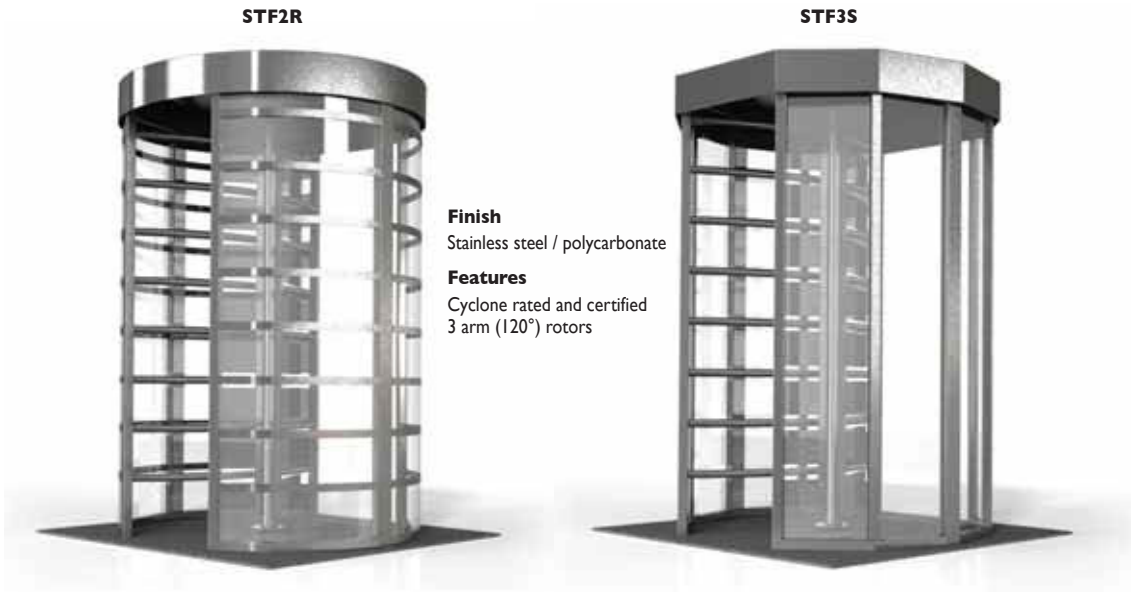

**Finish**  
Stainless steel / polycarbonate

**Features**  
Cyclone rated and certified  
3 arm (120°) rotors

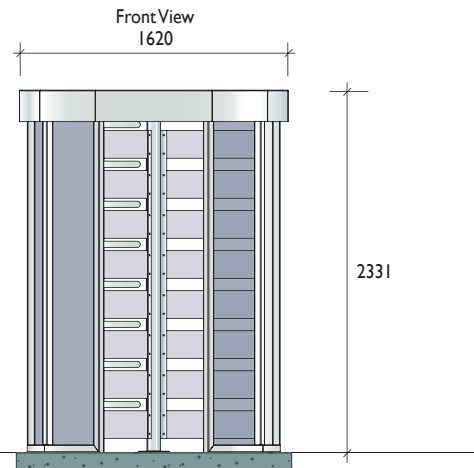
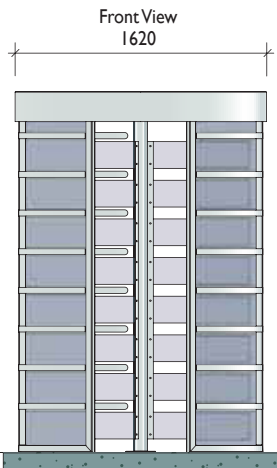
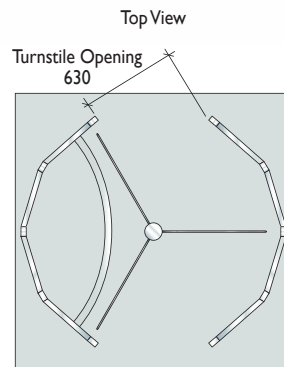
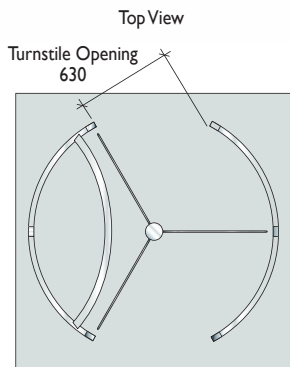

<b>Intro</b>	<b>2</b>
<b>Gates</b>	<b>14</b>
Track	20
Cantilever	30
Swing	40
Bi-fold	46
Boom	52
Options	76
General	82
<b>Barriers</b>	<b>94</b>
Blockers	100
Tyre Spikes	102
Pre-cast	106
Other	111
<b>Pedestrian</b>	<b>114</b>
Turnstiles	114
Gates & Doors	136
<b>Fencing</b>	<b>142</b>
<b>Code Index</b>	<b>153</b>

Leda full height turnstiles integrate with other access control systems and cater for a flow of up to 20 people per minute. Controllers can be configured to provide a range of functions (entry only / exit only / entry and exit). Recommended minimum for all concrete footings, 30MPa.



# Product Range > Pedestrian Access > Turnstiles Roofs

☎ 1300 780 450

## TROOF1

Weather protection for staff should be considered whenever full height turnstiles are installed externally. Leda can provide three standard options in cover, ranging from simple roof structures which attach to the top of the turnstile, to a free-standing shelter. Site specific solutions can also be engineered for larger and more complex projects. Refer to the Shelters section in Leda's Securabike *Bicycle Parking & Security Handbook* for a wider range of models.

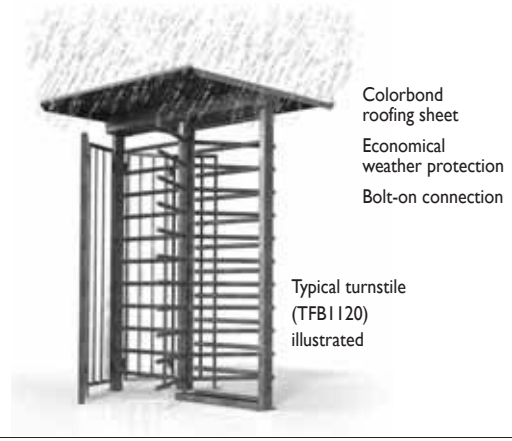
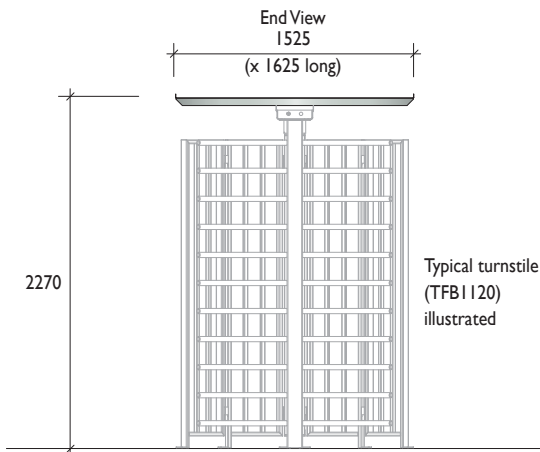

## TROOF2

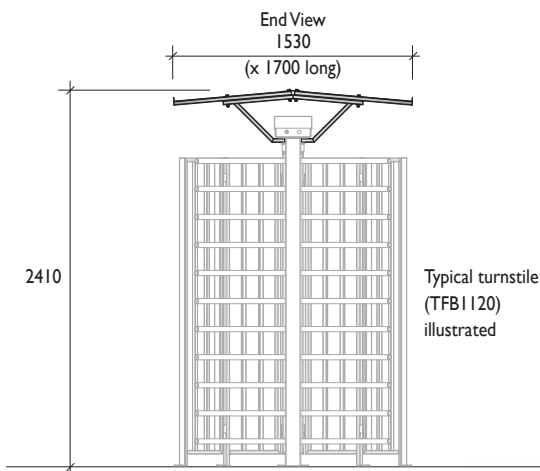

## TROOF3

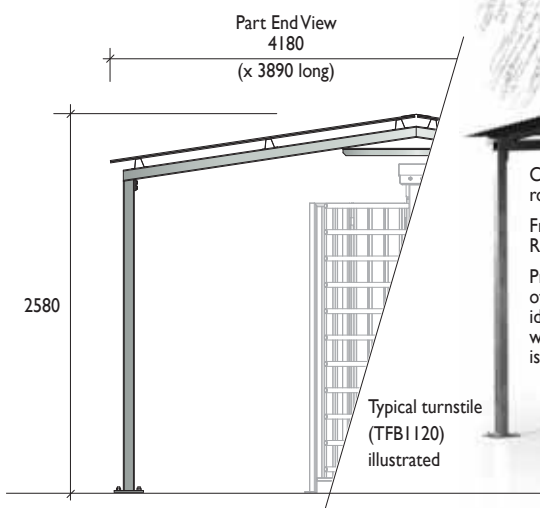

☎ 1300 780 450

Leda has a number of options that can be added to various Leda turnstiles to enhance their performance or appearance.

**Stainless Steel**

The majority of Leda’s turnstiles can be manufactured using either SS304 or SS316 stainless steel. Please check with your Leda sales office.

**Cyclone Rating**

Many Leda turnstiles are supplied to remote cyclone-affected locations. Leda engineers have strengthened TFL models, and the respective footing designs, to meet loading requirements of the appropriate Australian Standards.



**Solar Powered Operation (SOLART)**

Powers 240V AC turnstiles continuously. Includes IP66 Cabinet with regulator, batteries and GPO and 3 x solar panels with mounting post.

> For more information refer Options & Accessories on p77.

**Turnstile Adaptor Kit (TFREE)**

Upon power loss, allows the turnstile to freewheel in one direction only, making it fail safe. If the turnstile needs to freewheel in both directions, two kits are required.

**Pedestrian Pressure Pad (PRESSPAD)**

Pressure pad allows for free exit for pedestrians.

**Roofs (TROOF1/2/3)**

Weather protection for full height turnstiles installed outdoors.

> Refer p126 for details.



**Intro** 2

**Gates** 14

Track 20

Cantilever 30

Swing 40

Bi-fold 46

Boom 52

Options 76

General 82

**Barriers** 94

Blockers 100

Tyre Spikes 102

Pre-cast 106

Other 111

**Pedestrian** 114

Turnstiles 114

Gates & Doors 136

**Fencing** 142

**Code Index** 153



## Product Range > Pedestrian Access > Half-height Turnstiles

☎ 1300 780 450

Leda's half height turnstiles provide a range of various models that provide aesthetically attractive pedestrian access control for a wide array of entrances.

Leda turnstiles present a very high operating reliability, and can be supplied in either fail-safe or fail-secure options, with or without battery back-up and can be interfaced with the building's fire alarm panels. They are also designed to allow integration with all common access control systems.

Available in stainless steel (grade 304 or 316) galvanised or electrostatically powder coated in a range of colours. All stainless steel surfaces are finished to a class 4 satin finish.

### Applications

- Commercial offices
- Government buildings
- Retail outlets
- Schools and universities
- Stadiums and sporting venues
- Mining sites
- Building sites

Importantly, with branches across Australia, Leda's service technicians are never far away. Leda also offers a range of preventative maintenance contracts (PMC) designed to keep your turnstiles in prime operating condition.

> Refer to p93 for more information on service and maintenance programs.





☎ 1300 780 450

**HTFL1120**  
Titan Industrial

Durable and extremely reliable, this half height turnstile is ideal for use in harsh environments such as mining or building sites.

**HTFL1120S/D**  
Mild Steel  
**SHTFL1120S/D**  
Stainless Steel

- Features**
- High speed
  - Quiet operation
  - Mild or stainless steel
  - Self lubricating
  - Unaffected by dust, dirt or moisture and requires no maintenance
  - Mechanical override
  - Suspended rotary technology
  - Bi-directional operation



Guide Rail  
**BR120B**  
Mild Steel  
**SBR120B**  
Stainless Steel

**HTFL1120S**  
Single  
Top View

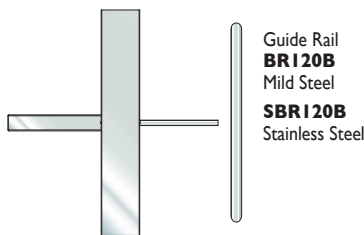

**HTFL1120D**  
Double  
Top View

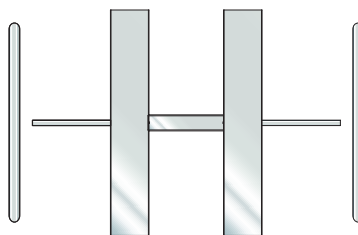

Front View  
1335

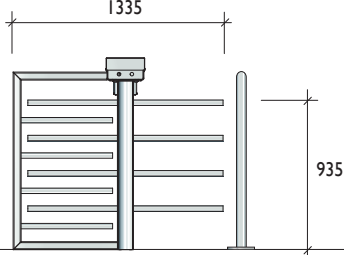

Front View  
1950

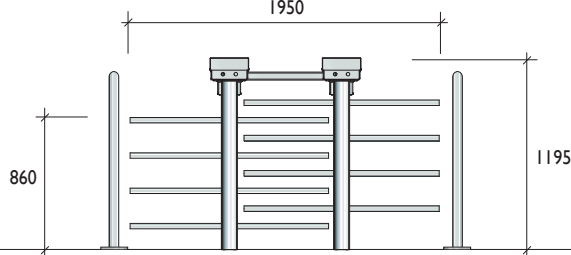

<b>Intro</b>	<b>2</b>
<b>Gates</b>	<b>14</b>
Track	20
Cantilever	30
Swing	40
Bi-fold	46
Boom	52
Options	76
General	82
<b>Barriers</b>	<b>94</b>
Blockers	100
Tyre Spikes	102
Pre-cast	106
Other	111
<b>Pedestrian</b>	<b>114</b>
Turnstiles	114
Gates & Doors	136
<b>Fencing</b>	<b>142</b>
<b>Code Index</b>	<b>153</b>

Providing low level security and pedestrian access.  
Operate on 230/240V AC 50Hz.  
Recommended minimum for all concrete footings, 30MPa.

Product Range > Pedestrian Access > Half-height Turnstiles

☎ 1300 780 450

**TH1**



**Finish**  
 TH1 Gal / powder coated  
 STH1 Stainless steel

**Features**  
 Continuous operation  
 Two direction passage  
 Integrated access control

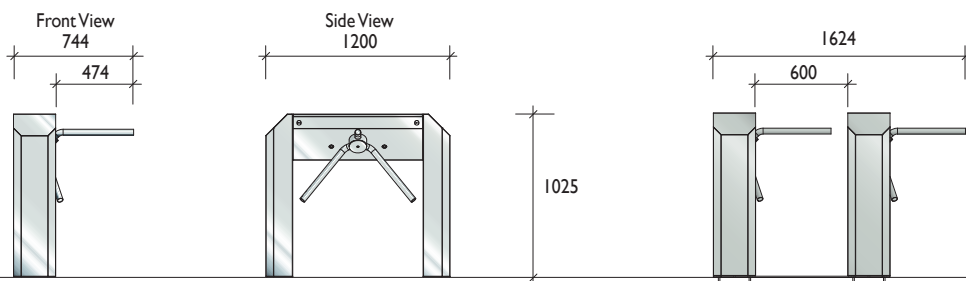

**STHSG1 L/I/R**

Typical triple configuration using left, intermediate and right unit



**Finish**  
 Stainless steel  
 Optional marble top  
 Acrylic arms (range of colours)

**Features**  
 Elegant style  
 Quick operating speeds  
 Directional symbols  
 Audio / visual alarm

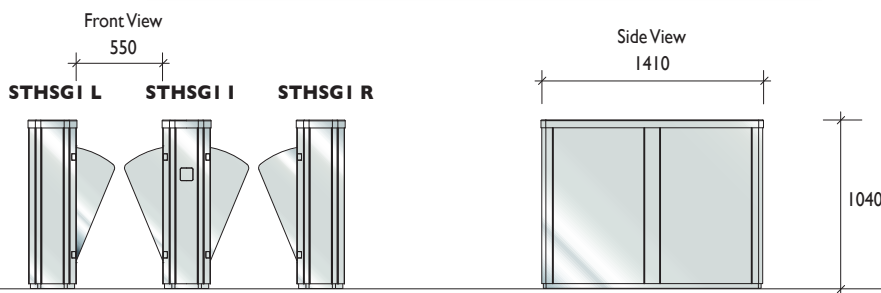

Providing low level security and pedestrian access.  
 Operate on 230/240V AC 50Hz.  
 Recommended minimum for all concrete footings. 30MPa.

1300 780 450

**SSG20 L/R**

**SSG20 L**  
Left handed



**SSG20 R**  
Right handed

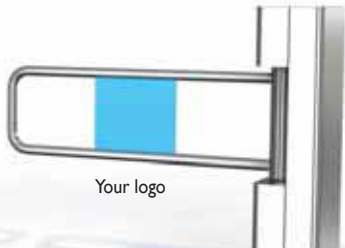

**Finish**

Stainless steel

**Features**

- Suitable for large goods entry
- 25-30 passages per minute
- Economical option
- Single or double configuration
- Left or right handed
- Lockable service panel

Arm length  
500-930

Your logo

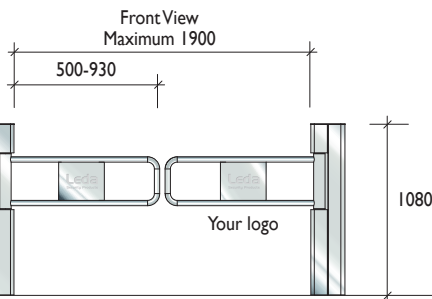

**SFBS0611/0911L/R**

Lobby / Reception  
Swing Barrier



**Finish**

- Galvanised steel / powder coated
- Stainless steel
- Glass/Acrylic panel 5mm thick

**Features**

- Quiet and compact
- Pivoting central column
- Single or double configuration
- 2 arm lengths
- Left or right handed



Single Opening

**SFBS0611L**  
600

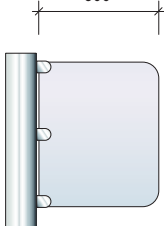

Double Opening

**SFBS0911L**

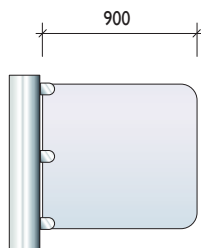

**SFBS0911R**

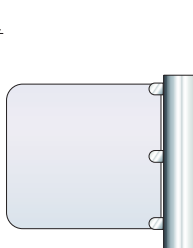

168

1000



Providing low level security and pedestrian access.  
Operate on 230/240V AC 50Hz.  
Recommended minimum for all concrete footings, 30MPa.

<b>Intro</b>	<b>2</b>
<b>Gates</b>	<b>14</b>
Track	20
Cantilever	30
Swing	40
Bi-fold	46
Boom	52
Options	76
General	82
<b>Barriers</b>	<b>94</b>
Blockers	100
Tyre Spikes	102
Pre-cast	106
Other	111
<b>Pedestrian</b>	<b>114</b>
Turnstiles	114
Gates & Doors	136
<b>Fencing</b>	<b>142</b>
<b>Code Index</b>	<b>153</b>



# Product Range > Pedestrian Access > Half-height Turnstiles

☎ 1300 780 450

**FBS1011L/R**  
Supermarket

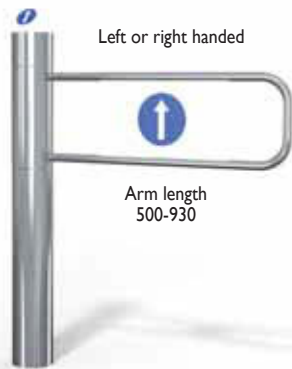

- Sensor controlled opening upon approach, with closing adjustable from 0-18 seconds.
- Stops automatically if object detected after the gate with operation continuing after the 'blockage' clears.
- The gate can also be operated by push button or remote control.
- For emergency situations, (such as fire escape) the gate can be manually pushed in the opposite direction activating a flashing light and alarm.
- If the gate is impeded in the opening process, the gate will try to open and close 3 times automatically. If the gate cannot clear the faults it will enter sleep mode until it is closed manually and reactivated with the auto adjust / control.

**Finish**  
Chrome / stainless steel  
White acrylic infill panel

**Features**  
Quiet and compact  
Pivoting central column  
Left or right hand  
Single or double configuration

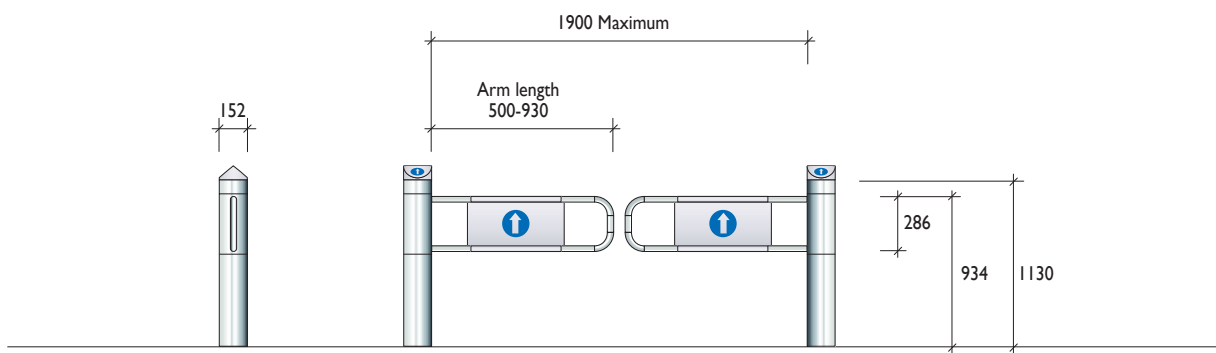

Providing low level security and pedestrian access.  
Operate on 230/240V AC 50Hz.  
Recommended minimum for all concrete footings, 30MPa.

1300 780 450

**GH1**  
Manual

Manual Operation  
Can be set up to open in one direction or in both directions



Commissioned by Sydney Ferries, these turnstile gates were designed to operate in harsh salt environments. Their wide passage allows large numbers of commuters to pass quickly.

**Finish**  
Stainless steel (grade 304 or 316)  
Galvanised steel / powder coated

**Features**  
Heavy duty / external applications  
Extra-wide passage  
Adjustable recessed spring

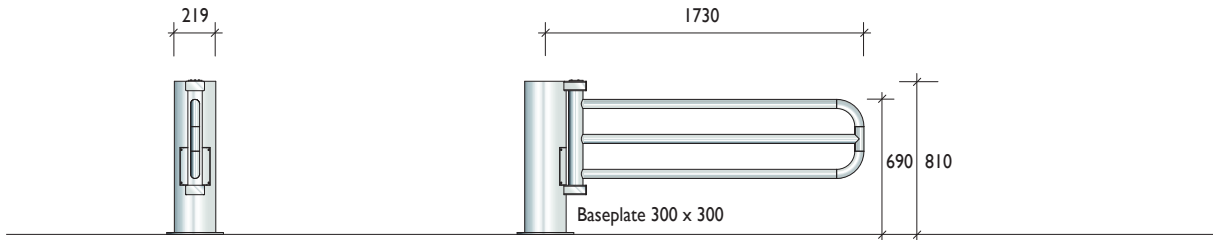

<b>Intro</b>	<b>2</b>
<b>Gates</b>	<b>14</b>
Track	20
Cantilever	30
Swing	40
Bi-fold	46
Boom	52
Options	76
General	82
<b>Barriers</b>	<b>94</b>
Blockers	100
Tyre Spikes	102
Pre-cast	106
Other	111
<b>Pedestrian</b>	<b>114</b>
Turnstiles	114
Gates & Doors	136
<b>Fencing</b>	<b>142</b>
<b>Code Index</b>	<b>153</b>

**PSWS1010**  
Manual

Manual Operation  
Can be set up to open in one direction or in both directions



Ideal for cafeterias or to prevent pass-back.

**Finish**  
Stainless steel (grade 304 or 316)

**Features**  
Single or dual leaves  
Gate closer included

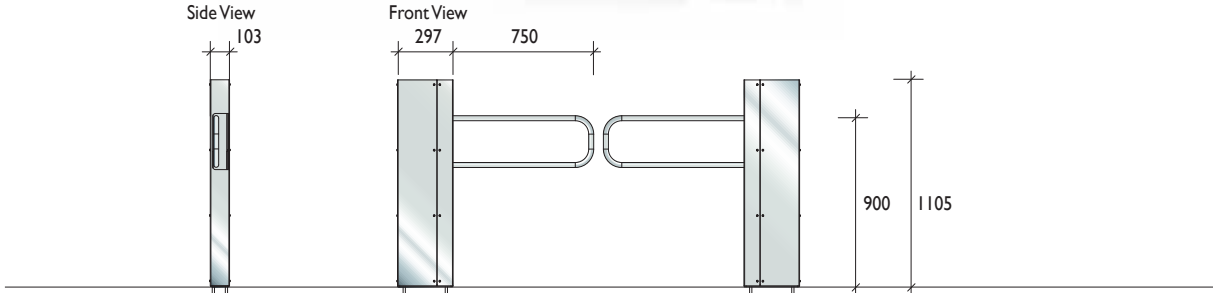

Providing low level security and pedestrian access.  
Operate on 230/240V AC 50Hz.  
Recommended minimum for all concrete footings, 30MPa.

☎ 1300 780 450

### TL900 Series Sliding Doors

This elegant design is the most versatile high security access control system available, and offers fast, controlled and bi-directional access. The TL900 Series has options for higher doors, and wider and longer passages.

**H Model** – Higher door provides increased security.

**L Model** – Extended passage length plus sensors provide a longer detection zone to optimise user flow.

**W Model** – Larger passage to cater for disabled access and bulky deliveries.

An advanced sensor system prevents the door wings from closing when a person or object is located in the safety zone. The optional high door wings are equipped with additional safety sensors.

### Applications

- Reception areas
- Commercial and government offices
- Rail and passenger terminals
- Museums and art galleries

### Specifications

Power 220-240V AC, 50/60Hz  
 Material Stainless Steel (Grade 304)  
 10mm tempered safety glass  
 Operation -15°C / +50°C

Product code	Unit Length mm	Passage Width mm	Wing Height mm	Unit Height mm	Overall Width mm	Capacity / Minute
<b>TL900</b>	1390	510	900	1030	1290	25-30
<b>TL900H</b>	1390	510	1200/1400/1600/1800	1030	1290	25-30
<b>TL900HL</b>	2580	510	1200/1400/1600/1800	1030	1290	25-30
<b>TL900L</b>	2580	510	900	1030	1290	25-30
<b>TL900W</b>	1390	910	900	1030	2090	25-30
<b>TL900HW</b>	1390	910	1200/1400/1600/1800	1030	2090	25-30
<b>TL900LW</b>	2580	910	900	1030	2090	25-30
<b>TL900HLW</b>	2580	910	1200/1400/1600/1800	1030	2090	25-30

### TL900 Series Sliding Doors



1300 780 450

### TL901 Series Swinging Doors

Another elegant model designed to cater for high capacity, high security access control.

A longer detection lane prevents tailgating.

In the rest position, the doors are locked closed, however 'open' mode is available and the swing door only closes if an unauthorised person tries to transit.

The TL901 Series is available in standard or extra wide for disabled access or bulky deliveries.

**S Model** – Higher door provides increased security.

**W Model** – Larger passage to cater for disabled access and bulky deliveries.

### Applications

- Reception areas
- Commercial and government offices
- Rail and passenger terminals
- Museums and art galleries

### Specifications

Power	220-240V AC, 50/60Hz
Weight	Standard Unit 420kg
Material	Stainless Steel (Grade 304) 8mm tempered safety glass
Operation	-15°C / +50°C

Product code	Unit Length mm	Passage Width mm	Wing Height mm	Unit Height mm	Overall Width mm	Capacity / Minute
<b>TL901S</b>	1900	500	900	1085	940	25-30
<b>TL901W</b>	1900	900	1200/1400/1600/1800	1085	1290	25-30

### TL901 Series Swinging Doors

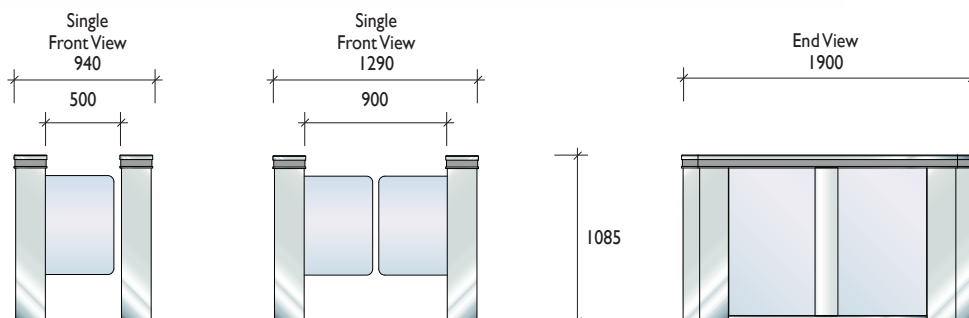

<b>Intro</b>	<b>2</b>
<b>Gates</b>	<b>14</b>
Track	20
Cantilever	30
Swing	40
Bi-fold	46
Boom	52
Options	76
General	82
<b>Barriers</b>	<b>94</b>
Blockers	100
Tyre Spikes	102
Pre-cast	106
Other	111
<b>Pedestrian</b>	<b>114</b>
Turnstiles	114
Gates & Doors	136
<b>Fencing</b>	<b>142</b>
<b>Code Index</b>	<b>153</b>



## Product Range > Pedestrian Access > Gates & Doors

☎ 1300 780 450

Leda's **pedestrian swing gates** are designed to provide a 1 metre opening, and are available in 1.8m, 2.1m or 2.4m heights.

The gates are available in different finishes and with a number of infill options. There are also options on locking mechanisms and automatic closers.

Pedestrian gates can be supplied as stand alone units or integrated with track and cantilever vehicular gates, turnstiles or fencing. Hinging can be left or right handed.

Leda **security doors** utilise 5 standard designs customised to fit existing doorways, and are available with a range of locking options.

> For options on locking mechanisms and automatic closers for pedestrian gates and doors, refer to p80.

### Disabled Access Kit

Leda's disabled access kit can be fitted to the RPGS Industrial gate.



Duty Level	Code	Width	Height Range	Infill Range °	Top Extension °	Post Fixing
<b>Premier</b>	<b>FPSS01</b> suits Premier fencing	1.0m only	1.8m / 2.1m / 2.4m	RHS Pickets only	TC only	Fixed or Baseplate
<b>Industrial</b>	<b>PRSS (Redfern)</b> suits Redfern fencing	1.0m only	1.8m / 2.1m / 2.4m	Flat Bar	N/a	Baseplate
	<b>RPGS (RAAF)</b>	1.25m only	2.125m	Full Range	Full Range on o/head rail	Baseplate
<b>Security</b>	<b>PSWS</b> no o/head rail	1.0m only	1.8m-2.7m 0.3m increments	Full Range	Full Range	Fixed or Baseplate
	<b>PSWSC</b> with o/head rail	1.0m only	2.1m-2.7m 0.3m increments	Full Range	Full Range on o/head rail	Fixed or Baseplate
<b>Security</b>	<b>Doors</b>	Custom	Custom	RHS Pickets	N/a	N/a

• Refer p76 for details

1300 780 450

<b>Intro</b>	<b>2</b>
<b>Gates</b>	<b>14</b>
Track	20
Cantilever	30
Swing	40
Bi-fold	46
Boom	52
Options	76
General	82
<b>Barriers</b>	<b>94</b>
Blockers	100
Tyre Spikes	102
Pre-cast	106
Other	111
<b>Pedestrian</b>	<b>114</b>
Turnstiles	114
Gates & Doors	136
<b>Fencing</b>	<b>142</b>
<b>Code Index</b>	<b>153</b>



**Premier Gate**  
suit Premier Fencing



**Industrial Redfern Gate**  
suit Redfern Fencing



**Industrial Gate**  
with optional disabled access kit

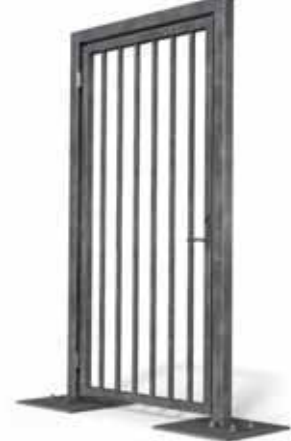

**Security Gate**  
with overhead rail option

Gates & doors displayed are shown left hand opening, viewed from the secure side. Right hand opening gates are also available.



**Security Door**  
with vertical pickets



**Security Door**  
with bracing



**Security Door**  
with double bracing



**Security Door**  
with horizontal pickets



**Security Door**  
with metal cladding

Padlock	Drop Bolt	Lock Options			Auto Closer	Finish		
		Mortice	Magnetic	Electric		Hot Dip Gal	Powdercoat	Wet Spray
Standard	Standard	N/a	N/a	N/a	N/a	Incl	Incl	Opt
N/a	N/a	Optional	Optional	Optional	Optional	Incl	N/a	Opt
Optional	Optional	Optional	Optional	Optional	Optional	Incl	N/a	Opt
Optional	Optional	Optional	Optional	Optional	N/a	Incl	Incl	Opt
Optional	Optional	Optional	Optional	Optional	Optional	Incl	Incl	Opt
Optional	Optional	Optional	N/a	N/a	Optional	Incl	Opt	Opt

Product Range > Pedestrian Access > Gates & Doors

1300 780 450

**Premier**  
FPSS01

**Fabrication**

Post  
65 x 65 RHS



Rail  
40 x 40 RHS



Pickets  
25 x 25 RHS

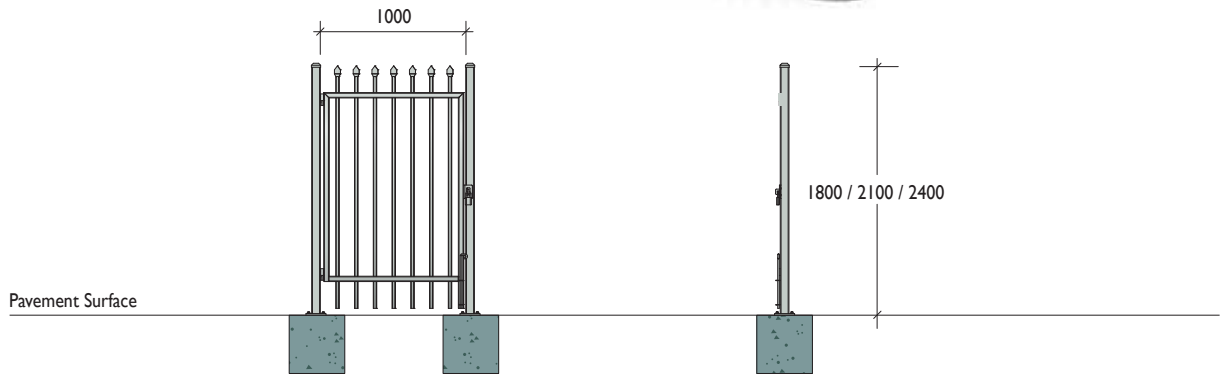
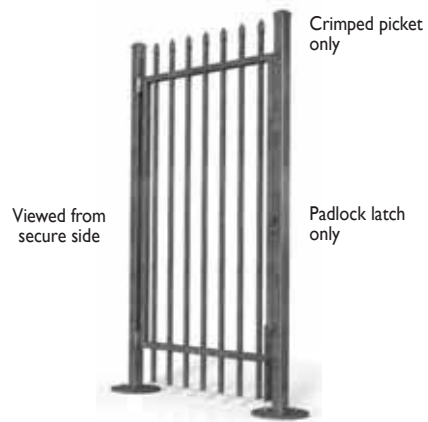

**Industrial**  
PRSS (Redfern)

**Fabrication**

Rail  
65 x 35 RHS



Pickets  
65 x 8 Flat Bar



Redfern profile  
is also available as:  
Track Gate refer p24  
Fencing refer p144

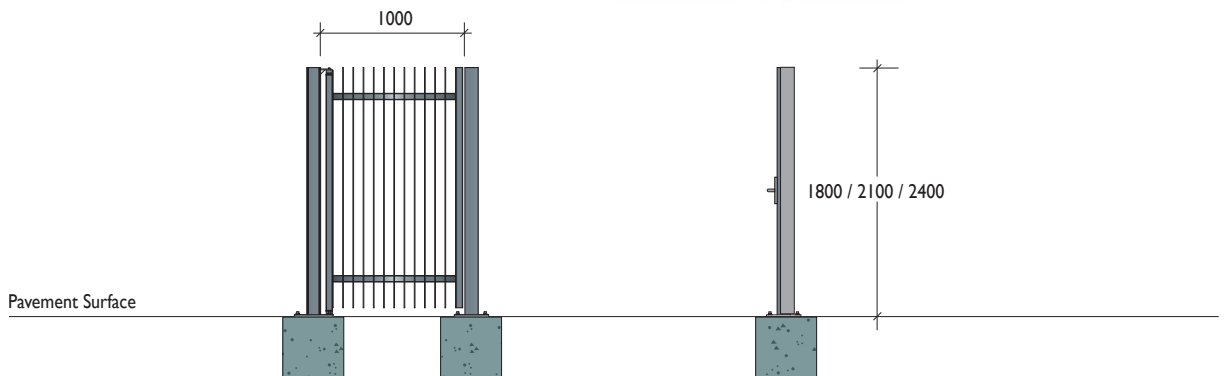

1300 780 450

**Industrial**

**RPGS**

**Fabrication**

Frame  
75 x 75 RHS



Frame  
50 x 50 RHS



Full range of gate infills  
> Refer to p76 for options



**Optional Disabled Access Kit**

- Low energy (DDA compliant) 240V / 2.5A
- Complies with emergency exit requirements
- Controlled via a PLC
- Programmable to work with access control systems
- Other options include UPS function, electric locking and safety sensor.

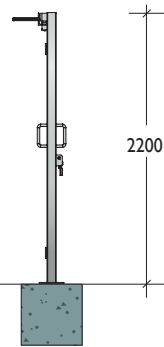
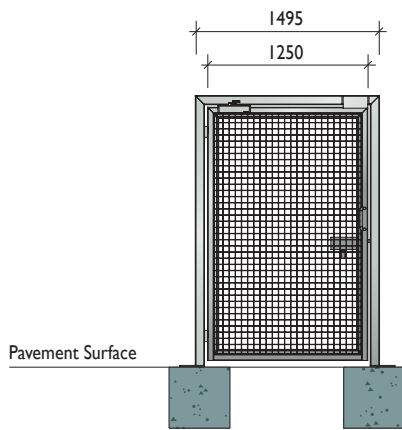

**Security**

**PSWS / PSWSC**

**Fabrication**

Post / O/head Rail  
75 x 75 RHS



Frame  
50 x 50 RHS



Full range of gate infills  
> Refer to p76 for options

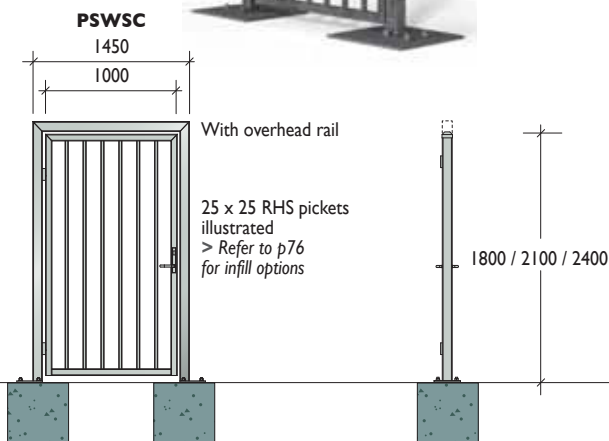
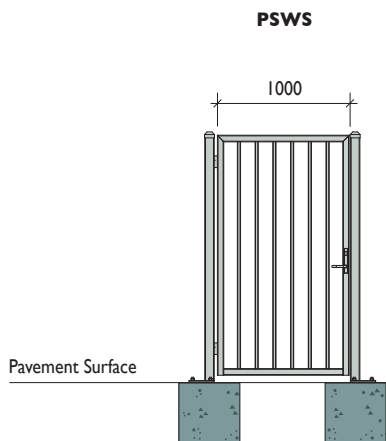

<b>Intro</b>	<b>2</b>
<b>Gates</b>	<b>14</b>
Track	20
Cantilever	30
Swing	40
Bi-fold	46
Boom	52
Options	76
General	82
<b>Barriers</b>	<b>94</b>
Blockers	100
Tyre Spikes	102
Pre-cast	106
Other	111
<b>Pedestrian</b>	<b>114</b>
Turnstiles	114
Gates & Doors	136
<b>Fencing</b>	<b>142</b>
<b>Code Index</b>	<b>153</b>



☎ 1300 780 450

Typical Pedestrian Gate Options

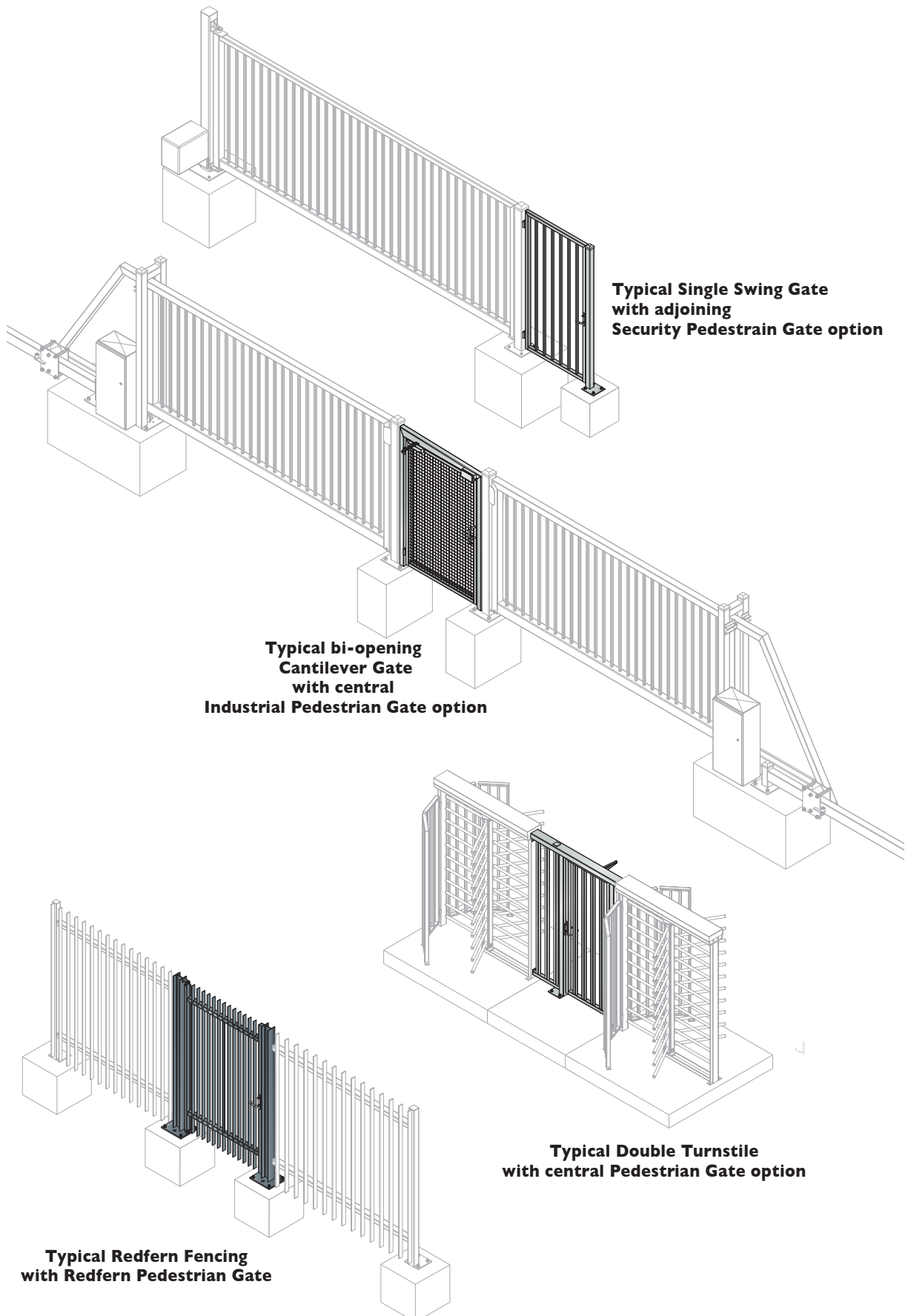

1300 780 450

### Security Doors

Leda's range of security doors are designed to provide the maximum physical security to doorways.

Manufactured from strong RHS steel sections, the doors are firmly fitted to a steel angle frame which is securely installed in the door frame.

Leda security doors utilise standard designs but are custom manufactured to fit each doorway.

#### Finish

Available in hot dipped galvanised or electrostatically powder coated in a range of colours.

#### Security Locking

Leda provides a range of locking options from manual key locking to electric magnet locks.

> Refer to p80 for pedestrian gates and doors lock options.

### Applications

- Commercial offices
- Government utilities
- Industrial factories
- High security sites
- Residential houses and apartments

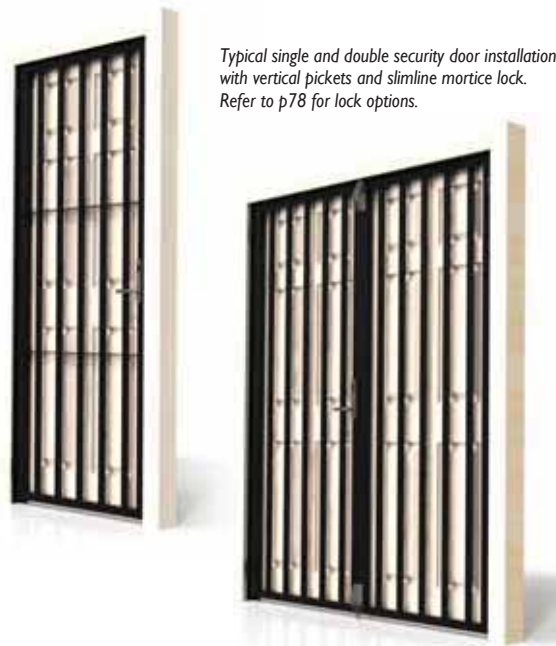

Typical single and double security door installation with vertical pickets and slimline mortice lock. Refer to p78 for lock options.



Double security door bolt detail

## Security Doors

#### Fabrication

Frame  
40 x 40 RHS



Pickets  
25 x 25 RHS



#### Options

- Double door configuration
- Matching window security frames
- Fly screen cover
- Security mesh

50 x 50 angle frame secured to existing door frame

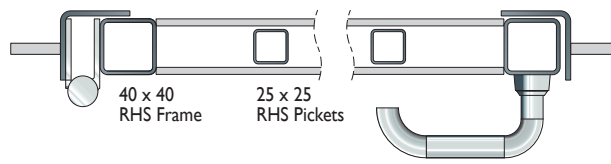

#### Detail Section

40 x 40 RHS Frame

25 x 25 RHS Pickets

Shown with slimline mortice lock.  
> Refer to p80 for lock options

#### Vertical Pickets SDVP01

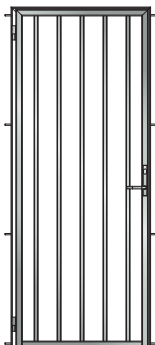

50 x 50 angle frame secured to existing door frame

40 x 40 RHS door frame

#### Horizontal Bracing SDVP02

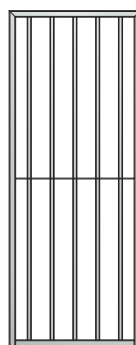

#### Double Bracing SDVP03



#### Horizontal Pickets SDHP04

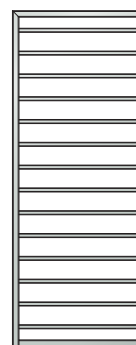

#### Metal Cladding SDMC05



<b>Intro</b>	<b>2</b>
<b>Gates</b>	<b>14</b>
Track	20
Cantilever	30
Swing	40
Bi-fold	46
Boom	52
Options	76
General	82
<b>Barriers</b>	<b>94</b>
Blockers	100
Tyre Spikes	102
Pre-cast	106
Other	111
<b>Pedestrian</b>	<b>114</b>
Turnstiles	114
Gates & Doors	136
<b>Fencing</b>	<b>142</b>
<b>Code Index</b>	<b>153</b>

## Product Range > Fencing

☎ 1300 780 450

Fencing forms one of the most important components of perimeter security as it helps define the parameters of a secure area through the physical barrier and detection capabilities it provides.

Leda regards fencing, and the integration of other perimeter security equipment, as a very important component of any perimeter security installation.

As Australia's only fully-integrated perimeter security manufacturer, Leda is able to offer a broad range of supporting products with end-to-end solutions.

This includes designing, specifying, manufacturing, integrating, installing and servicing the complete range of perimeter security products.



**Premier**



**Palisade**



**Sports**



**Redfern**



**Bastille**

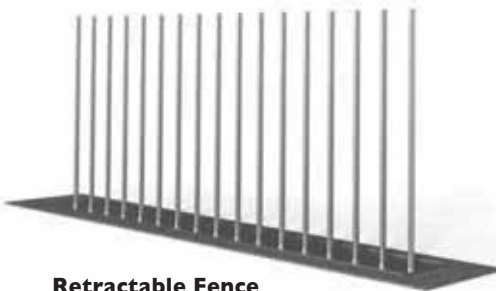

**Retractable Fence**



**Retractable Gate**



**Securamesh**

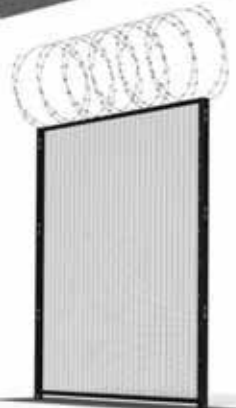

**High Security Securamesh**



**Security FAXP**



**Impact Fence**



**High Security Bristorm**

# Product Range > Fencing

# Fencing

1300 780 450

## Premier FP27TC

### Fabrication

Post  
65 x 65 RHS



Rails  
40 x 40 RHS



Pickets  
25 x 25 RHS



### Detail

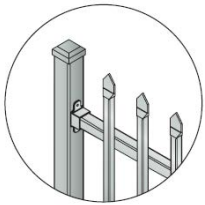

Viewed from  
secure side



Fixed and Baseplate  
models available

Pavement Surface

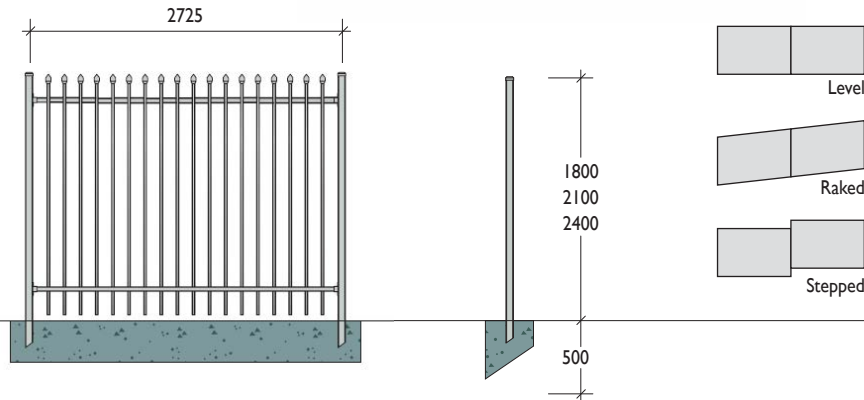

## Palisade FP26

### Fabrication

Post  
100 x 45 Beam



Rail  
50 x 50 Angle



Pickets  
'W' Pale



### Detail

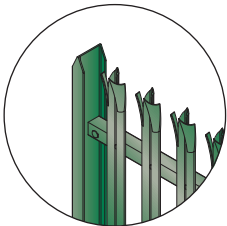

Anti-climb profile  
Tamper-resistant fittings

Viewed from  
secure side



Fixed and Baseplate  
models available

Pavement Surface

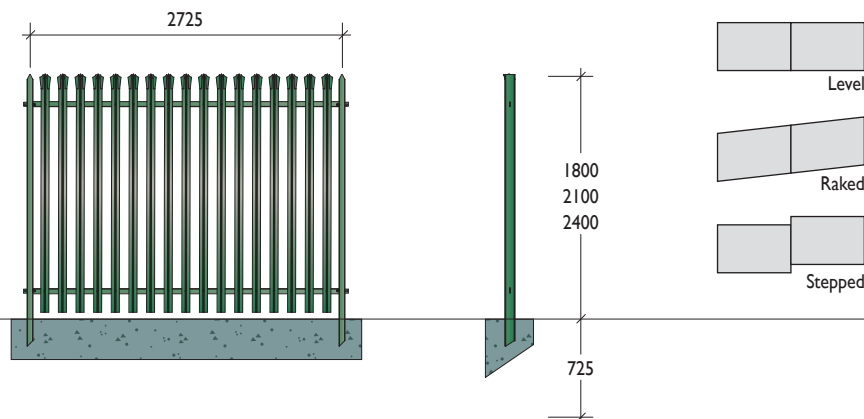

**Intro** 2

**Gates** 14

Track 20

Cantilever 30

Swing 40

Bi-fold 46

Boom 52

Options 76

General 82

**Barriers** 94

Blockers 100

Tyre Spikes 102

Pre-cast 106

Other 111

**Pedestrian** 114

Turnstiles 114

Gates & Doors 136

**Fencing** 142

**Code Index** 153



# Product Range > Fencing

1300 780 450

## Redfern FR26

### Fabrication

Post  
75 x 75 RHS



Rail  
75 x 50 RHS



Pickets  
50 x 8 Flat Bar



### Detail

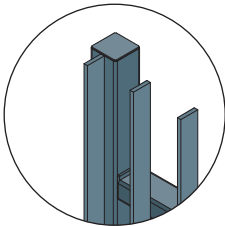

Redfern profile is also available as:  
Track Gate refer p24  
Pedestrian Gate refer p138

- > Matching Swing Gates available, refer p43 for details.
- > Redfern Pedestrian Gates available, refer p138 for details.

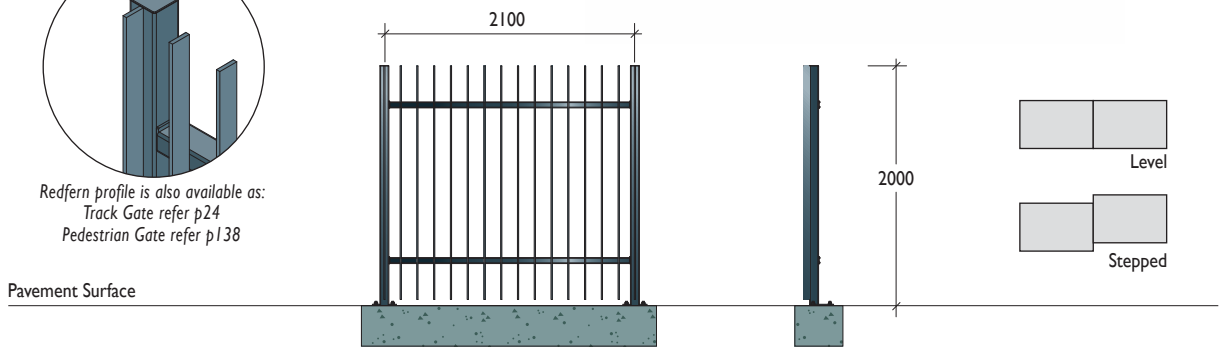

## Sports FSR

### Fabrication

Rail  
65 x 16 Flat Bar



Pickets  
65 x 8 Flat Bar



### Detail

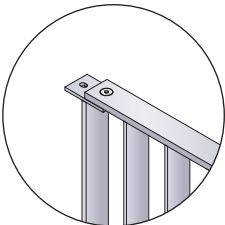

- > Matching Swing Gates available, refer p43 for details.



The low height Sports fence is designed as a strong and durable surround for sporting pitches and playing areas.

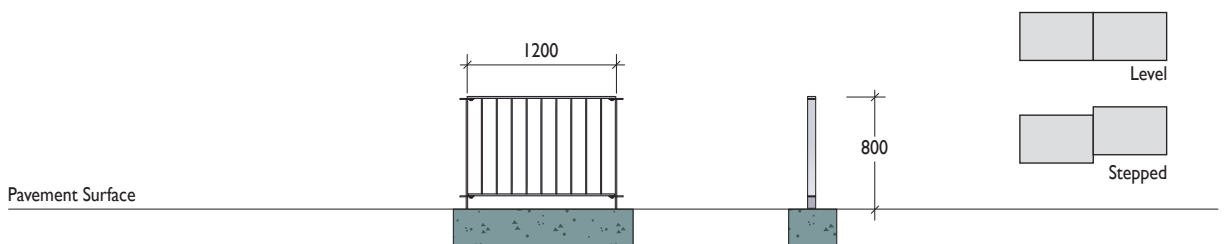

# Product Range > Fencing

# Fencing

1300 780 450

## Bastille

FB32R

### Fabrication

Pickets

32NB



FB32R

Galvanised Steel

SFB32R

Stainless Steel

### Detail

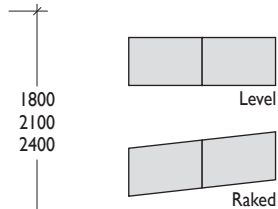
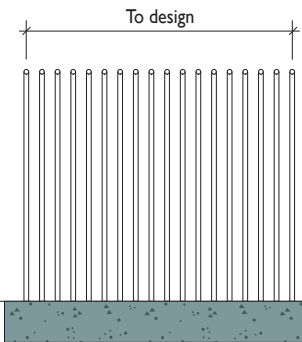
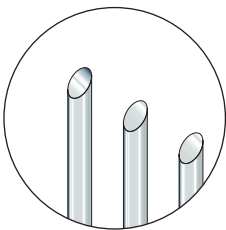

1800  
2100  
2400

Pavement Surface

## Securamesh

FS2624

### Fabrication

Post

104 x 3.2 Channel



Infill

4mm Ø wire  
welded 71mm x 9mm

### Detail

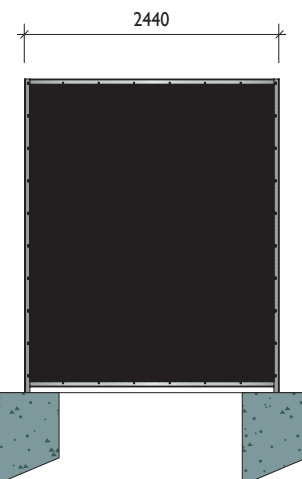
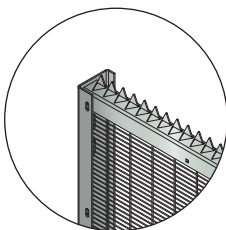

Sharktooth top



4mm Ø wire  
71mm x 9mm  
aperture

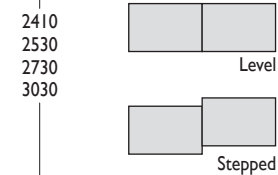

2410  
2530  
2730  
3030

790-1050

Pavement Surface

Intro 2

Gates 14

Track 20

Cantilever 30

Swing 40

Bi-fold 46

Boom 52

Options 76

General 82

Barriers 94

Blockers 100

Tyre Spikes 102

Pre-cast 106

Other 111

Pedestrian 114

Turnstiles 114

Gates & Doors 136

Fencing 142

Code Index 153

# Product Range > Fencing

1300 780 450

## High Security

### FHS

#### Fabrication

Post  
150 x 90 x 10 Channel

Mesh Infill  
4mm Ø wire  
welded 71mm x 9mm

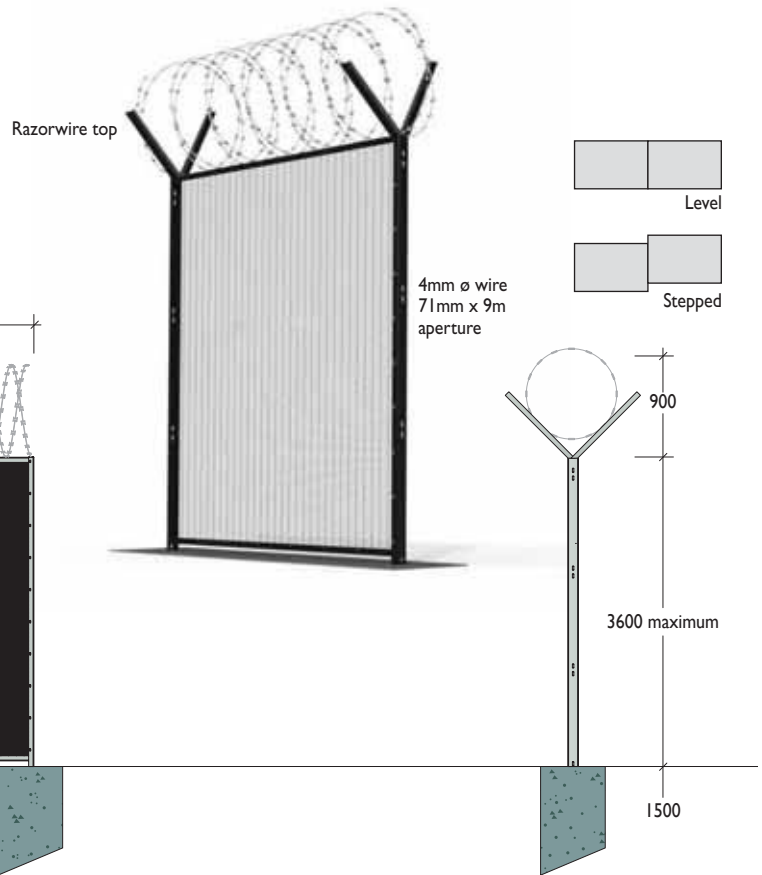

Pavement Surface

## High Security

### Bristorm BLPA

#### Tested to PAS68

(7500kg @ 48km/h)

Provides uninterrupted line of sight beyond the Bristorm perimeter.

**PAS68  
TESTED**

#### Installation

Must be installed in straight lengths with 20-100 metres between anchors. Tensioned ropes require little or no maintenance over the lifetime of the installation.

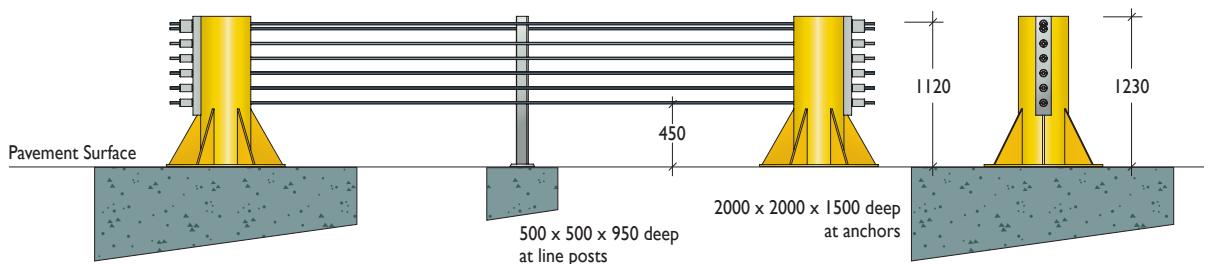
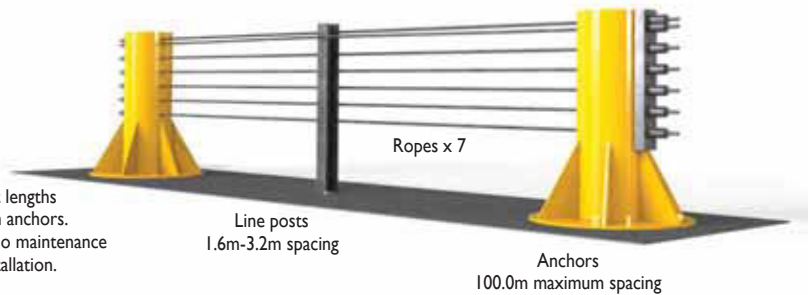

# Product Range > Fencing

# Fencing

1300 780 450

## High Security Impact LIF25

**ENGINEERED SOLUTION**

**LIF25** 2.5 tonnes @ 40km/h

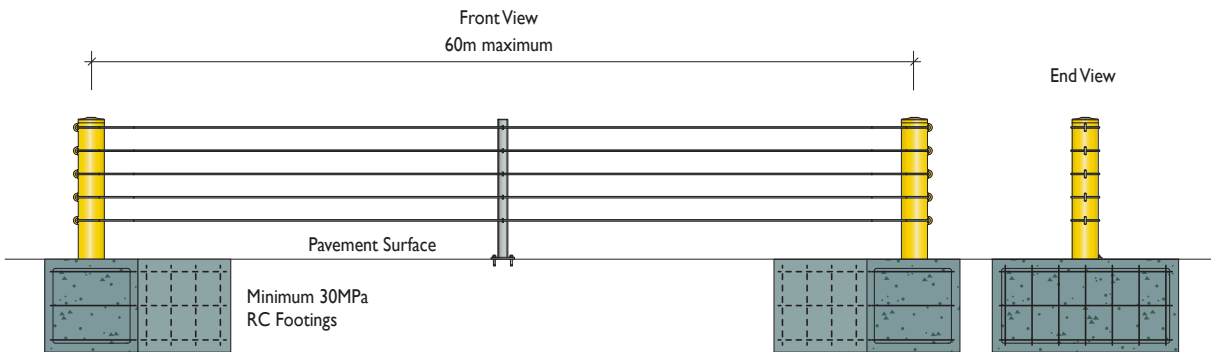
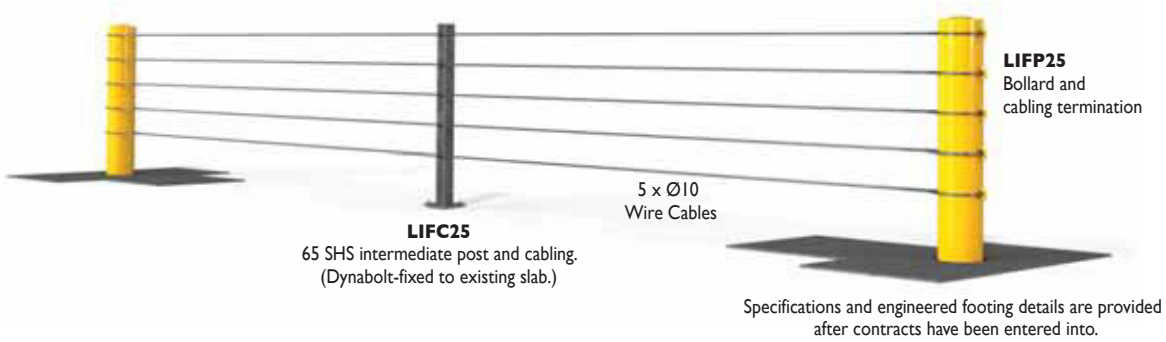

## High Security Impact LIF35

**ENGINEERED SOLUTION**

**LIF35** 3.5 tonnes @ 48km/h

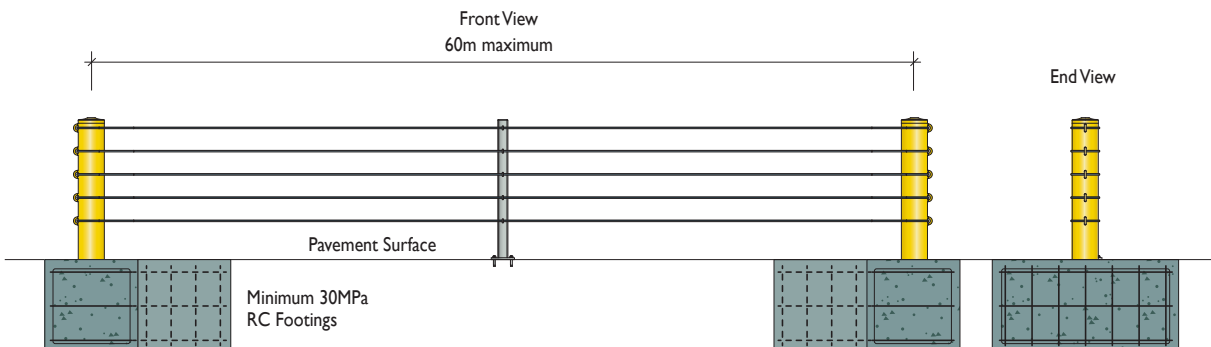
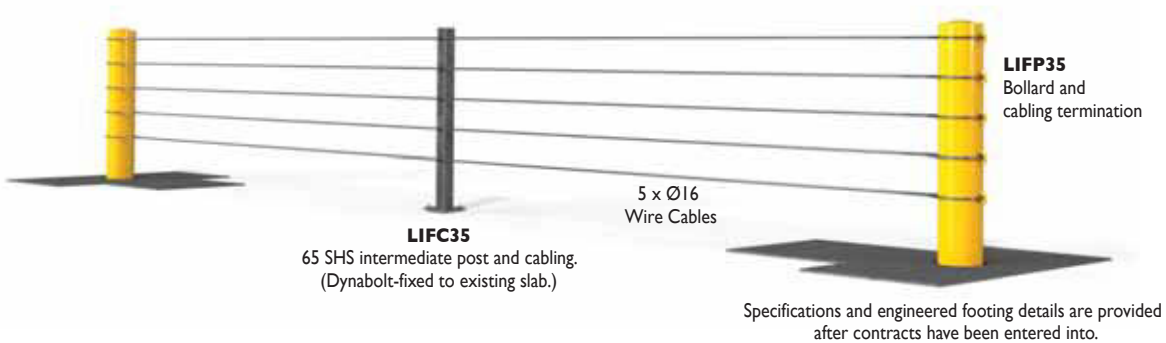

<b>Intro</b>	<b>2</b>
<b>Gates</b>	<b>14</b>
Track	20
Cantilever	30
Swing	40
Bi-fold	46
Boom	52
Options	76
General	82
<b>Barriers</b>	<b>94</b>
Blockers	100
Tyre Spikes	102
Pre-cast	106
Other	111
<b>Pedestrian</b>	<b>114</b>
Turnstiles	114
Gates & Doors	136
<b>Fencing</b>	<b>142</b>
<b>Code Index</b>	<b>153</b>



# Product Range > Fencing

1300 780 450

## FAXP Fence

A unique, versatile security fence that is simple and quick to install.

> Optional inserted detection system refer p149 for details

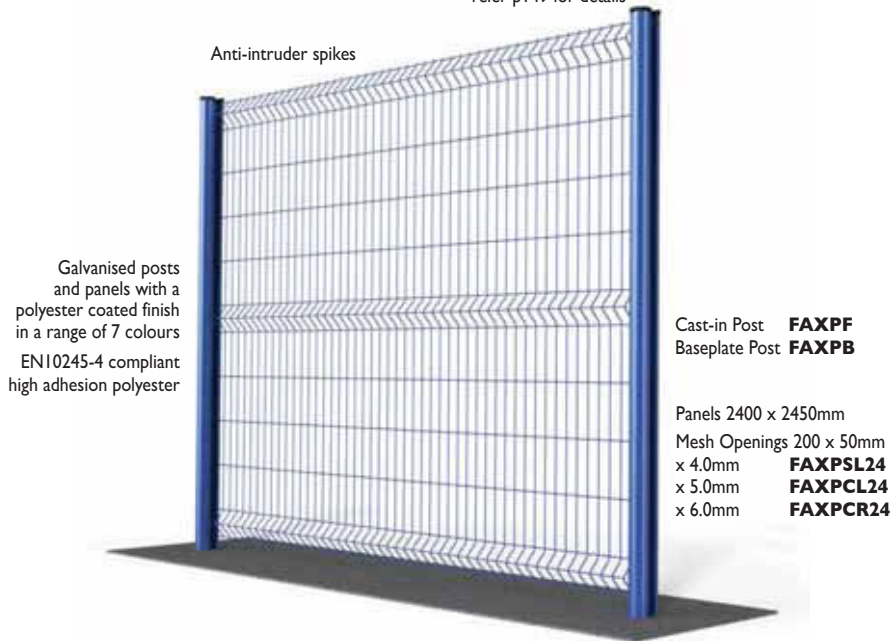

### Features

- Quick installation, no accessories required
- All configurations possible with the same post
- Adaptable to various ground constraints, curves, corners and slopes
- Stylish, fluid lines
- Difficult to penetrate once installed
- Defensive spikes (24mm high) provide deterrent

### Options

- Detection sensors
- LED post lighting
- Barb or razor wire extensions

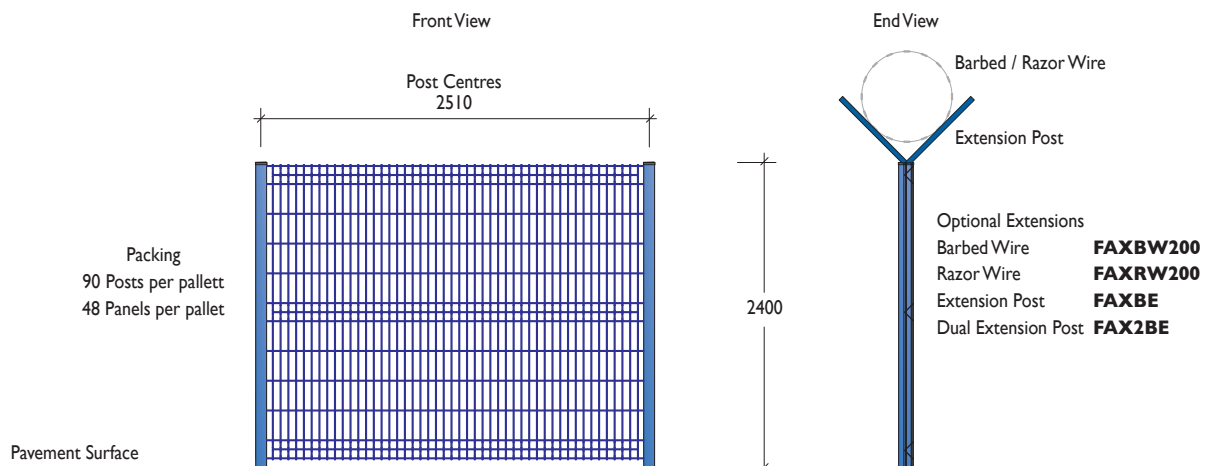

1300 780 450

**Intruder Detection System**

Sensor Detect is an economical, automatic detection system which is quick and easy to install onto new or existing fences. The sensors will be installed by Leda technicians while integrating the surveillance software into your security system.

The system is designed to detect intruders before they enter the premises. It detects impacts to the entire fence surface:

- shearing or cutting
- climbing or lifting
- pinpoints the intrusion zone to the specific detector

The Leda Sensor Detect comprises the following:

**FDSS** Sensor – fitted to the top of each FAXP post (battery powered). Service life of 2 years.

**FDSP** Sensor – external and cabled.

**FDSR** Router – relays information between the sensor and the hub

**FDSH** Hub – retrieves information from the sensors, ethernet connection to PC

Surveillance Software – used to set up the system’s different elements



FDSS internal post detector.



FDSP cabled exterior detector can be retrofitted to some fences.

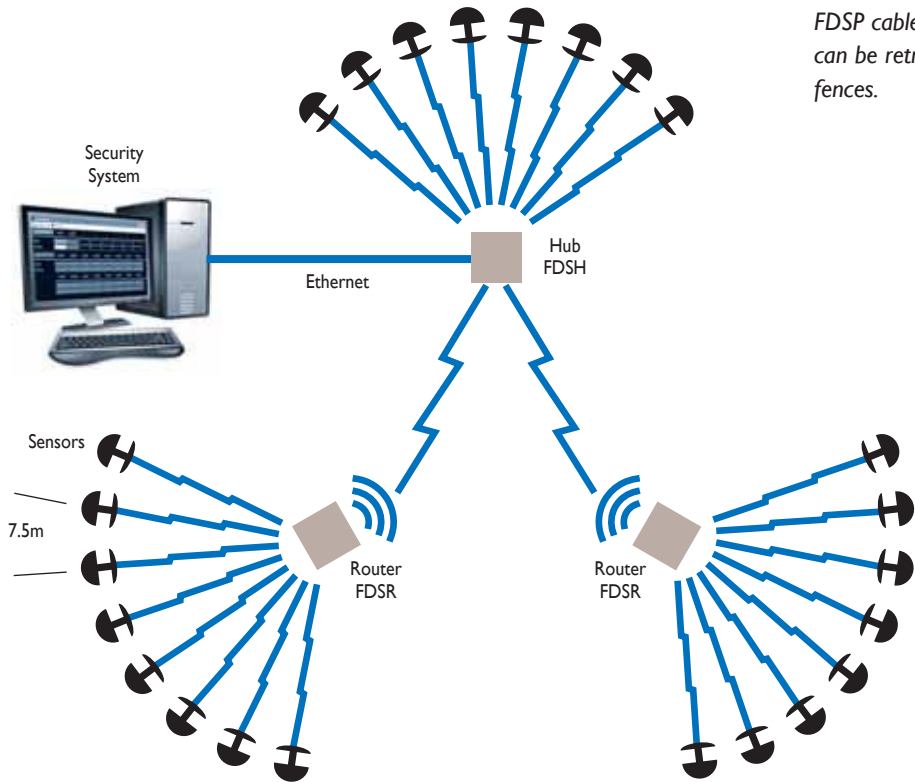

**Intro** 2

**Gates** 14

Track 20

Cantilever 30

Swing 40

Bi-fold 46

Boom 52

Options 76

General 82

**Barriers** 94

Blockers 100

Tyre Spikes 102

Pre-cast 106

Other 111

**Pedestrian** 114

Turnstiles 114

Gates & Doors 136

**Fencing** 142

**Code Index** 153

# Product Range > Fencing

☎ 1300 780 450

## Retractable Fence

FBR12

### Fabrication

- Pickets  
25m Ø aluminium tube
- 
- Cover Plate  
Stainless steel sheet
- Subframe  
Galvanised MS angle
- Cladding  
3mm galvanised sheet

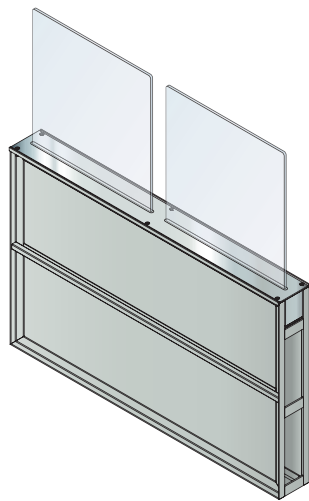
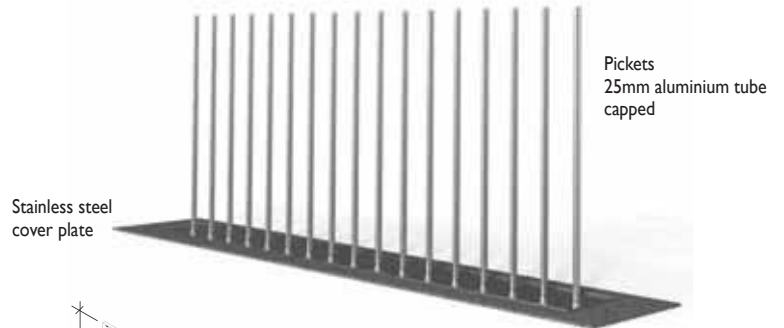

Typical modular unit using retractable safety glass panels

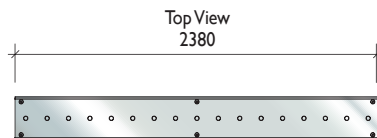
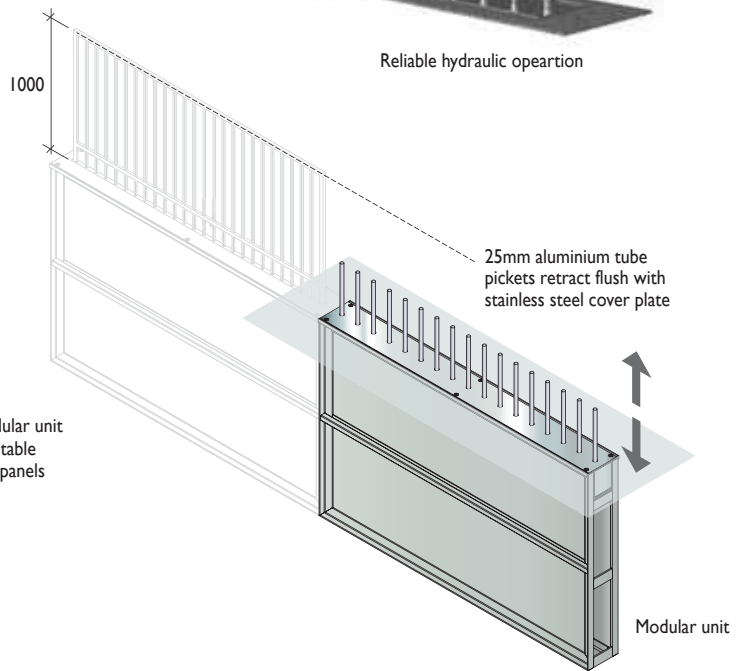

Top View  
2380

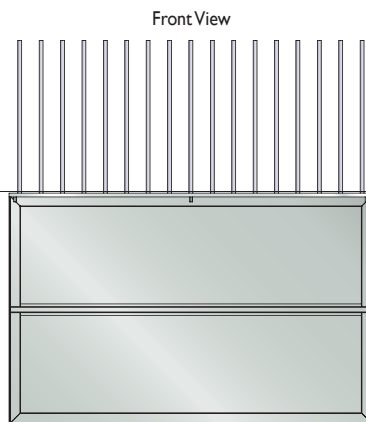

Front View

Pavement Surface

Side View  
282

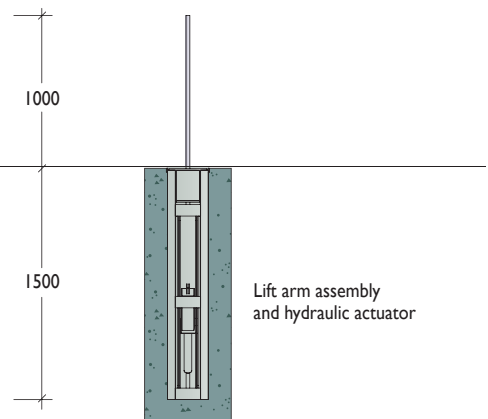

Lift arm assembly and hydraulic actuator

# Product Range > Fencing

1300 780 450

## Retractable Gate RG21

### Fabrication

- Gate Frame  
Galvanised MS Channel
- Gate Infill  
To design
- Cover Plate  
Stainless steel sheet
- Subframe  
Galvanised MS angle
- Subframe Cladding  
3mm galvanised sheet



Top View

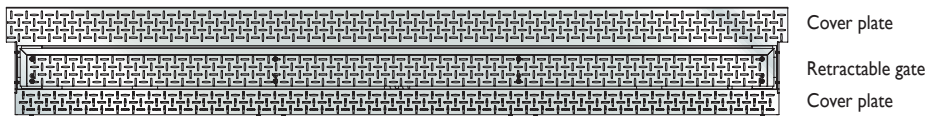

Front View

End View

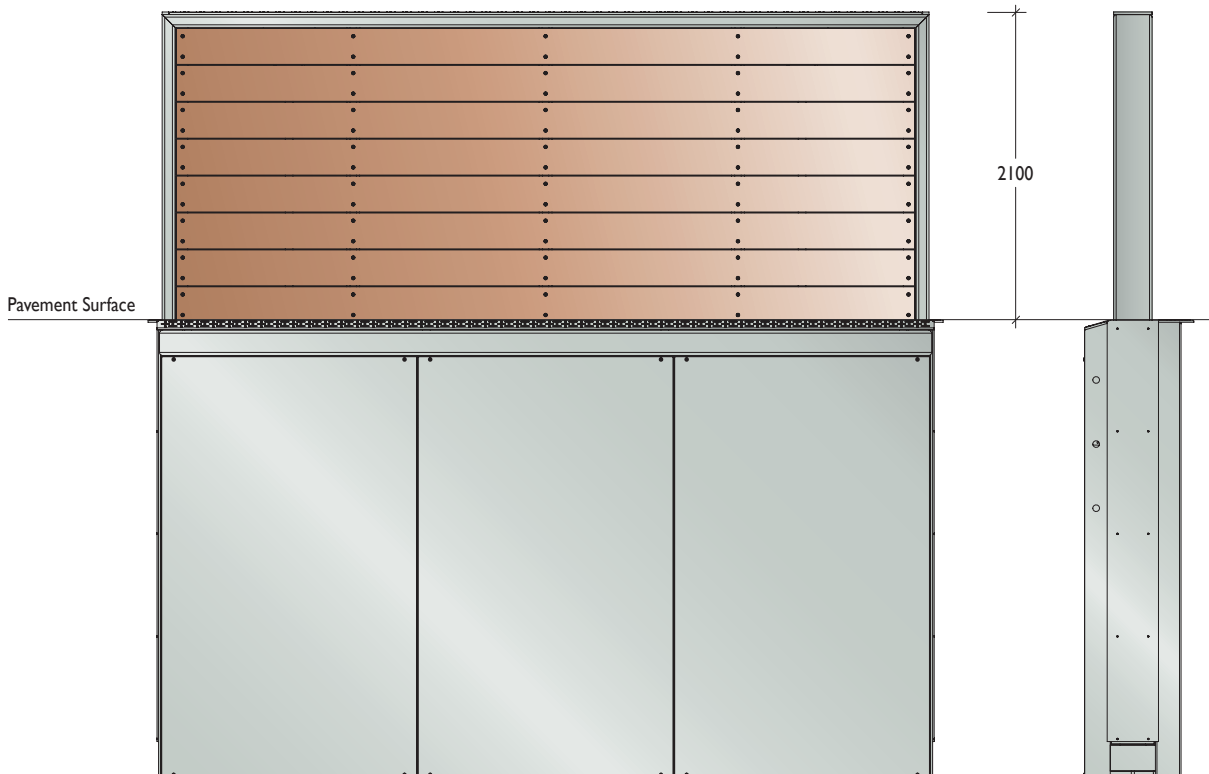

# Fencing

<b>Intro</b>	<b>2</b>
<b>Gates</b>	<b>14</b>
Track	20
Cantilever	30
Swing	40
Bi-fold	46
Boom	52
Options	76
General	82
<b>Barriers</b>	<b>94</b>
Blockers	100
Tyre Spikes	102
Pre-cast	106
Other	111
<b>Pedestrian</b>	<b>114</b>
Turnstiles	114
Gates & Doors	136
<b>Fencing</b>	<b>142</b>
<b>Code Index</b>	<b>153</b>



## Product Range > Fencing

☎ 1300 780 450

### Rubbish Enclosures

The enclosures provide ideal screening of unsightly refuse stations and wheelie bins.

Manufactured from rigid steel sections and clad using modular steel mesh panels or solid sheet metal, Leda can tailor the size of the enclosures to the site requirements. Modular frames are simply bolted together and fixed to the pavement using masonry anchors.

Rubbish enclosures are normally finished in powder coated black to be unobtrusive, or can be supplied in hot dipped galvanised finish for industrial applications.

### Applications

- Apartment buildings
- Commercial offices
- Industrial complexes

Photo renderings are indicative only.  
Leda will custom design and manufacture using modular panels to suit site requirements.



50 x 50 x 4mm galvanised wire mesh  
on galvanised mild steel angle frame

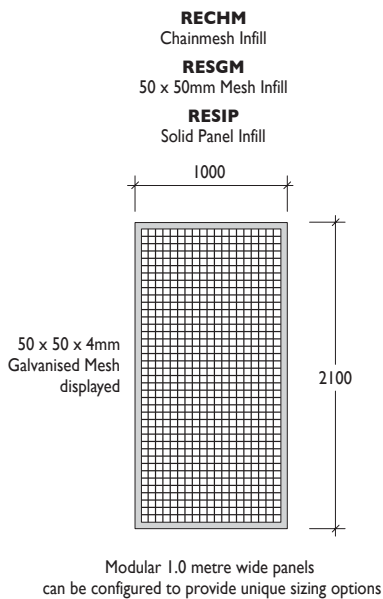

Gate openings  
can be altered to accommodate  
larger industrial skips

Galvanised metal infill panels  
on galvanised mild steel angle frame

1300 780 450

Code	Product Group	Details	Page
ABFDT	Gate Bi-Fold	Security Trackless Double Sided	50
AMTS	Gate Track	Advantage Modular	22
ANB33580	Gate Boom	Vertical High Security Automatic	66
ANB37548	Gate Boom	Vertical High Security Automatic	66
ANB47548	Gate Boom	Vertical High Security Automatic	66
ARSG45	Gate Track	Anti-terrorist	27
ASD	Gate Swing	Advantage Dual	42
ASS	Gate Swing	Advantage Single	42
ATS	Gate Track	Advantage Standard	22
BFGDF	Gate Bi-Fold	Industrial O'head Track High Speed	49
BFGDS	Gate Bi-Fold	Industrial O'head Track Double Sided	49
BFGDT	Gate Bi-Fold	Advantage Double Sided	48
BFGSF	Gate Bi-Fold	Industrial O'head Track High Speed	49
BFGSS	Gate Bi-Fold	Industrial O'head Track Single Sided	49
BFGST	Gate Bi-Fold	Advantage Single Sided	48
BGABS	Gate Boom	Vertical Boom Stand	60
BGAPS04	Gate Boom	Vertical Boom Support	60
BIB	Vehicle Barriers	Barrier in a Box	98
BLPA	Fencing	High Security Bristorm Fencing	146
BR120B	Pedestrian Access	Turnstile (HTFL1120) Gal Guide Rail	129
BR410	Gate Boom	Vertical Security Automatic	62
BR4204	Gate Boom	Vertical Security Automatic	63
BR4205	Gate Boom	Vertical Security Automatic	63
BR4206	Gate Boom	Vertical Security Automatic	63
BRFBI120	Pedestrian Access	Bicycle Entry Turnstile 0.9m Bar	120
BS04	Signage	Stencil Stop	85
BS05	Signage	Stencil Up Arrow	85
BS06	Signage	Stencil Slow	85
BS07	Signage	Stencil Left and Right	85
BS08	Signage	Stencil Left	85
BS09	Signage	Stencil Right	85
BS10	Signage	Stencil Left Up Right	85
BS11	Signage	Stencil Left Up	85
BS12	Signage	Stencil Up Right	85
CBGATE	Options & Access	Gate Infill Colorbond®	76
CGI119	Vehicle Barriers	Steel Corner Guard	113
CGI2	Gate Cantilever	Anti-terrorist	37
CG1529	Vehicle Barriers	Steel Corner Guard	113
CGT	Gate Track	Anti-terrorist	27
CHAINGATE	Options & Access	Gate Infill Chain Link Mesh	76
CHR90C	Vehicle Barriers	Steel Guard Suspended Height Rail	113
CLA	Gate Cantilever	Advantage	32
CLS	Gate Cantilever	Security	36
CLSH	Gate Cantilever	High Security	37
CLSL	Gate Cantilever	Security	36
CP75B	Vehicle Barriers	Steel Guard Column Protector	113

Code	Product Group	Details	Page
CPB10	Vehicle Barriers	Chain Barrier	96
CRTWGH	Options & Access	Counter Weighing of Gates	79
CSG	Gate Boom	Swing Boom Security Cityscape	71
D941	Gate Boom	Vertical High Security Automatic	65
D942	Gate Boom	Vertical High Security Automatic	65
D943	Gate Boom	Vertical High Security Automatic	65
DDDROP	Options & Access	Vertical Drop Bold	80
DDFREE	Options & Access	Free-to-exit Setup	80
DDJAMB	Options & Access	Pedestrian Swing Gate Door Jamb Bkt	80
DDJAMF	Options & Access	Pedestrian Gate Door Jamb Bracket	80
DDLCK	Options & Access	Lockwood Slimline Mortice Lock Kit	80
DDMAG	Options & Access	Electronic Magnetic Lock	80
DDPAD	Options & Access	Horizontal Sliding Padbolt	80
DDSCREEN	Options & Access	Polycarbonate Screen Door Lock	80
DEF950	Vehicle Barriers	Road Blocker Shallow Mount	101
DG41F	Vehicle Barriers	Steel Downpipe Guard	113
DOORS	Pedestrian Access	Security Doors	141
DP970	Pedestrian Access	Full Turnstile High Security	124
DSG	Gate Boom	Swing Advantage Dual	68
ES200	Options & Access	Electric Spike	80
FAX2BE	Fencing	Security Fencing Dual Extension Post	148
FAXBE	Fencing	Security Fencing Extension Post	148
FAXBW200	Fencing	Security Fencing Barbed Wire	148
FAXRW200	Fencing	Security Fencing Razor Wire	148
FAXPB	Fencing	Security Fencing Post / Baseplate	148
FAXPCL24	Fencing	Security Fencing Panel 5mm Wire	148
FAXPCR24	Fencing	Security Fencing Panel 6mm Wire	148
FAXPF	Fencing	Security Fencing Post / Cast-in	148
FAXPSL24	Fencing	Security Fencing Panel 4mm Wire	148
FB32R	Fencing	Bastille Fencing	145
FBR12	Fencing	Retractable Fencing	150
FBS101IL	Pedestrian Access	Half Turnstile Supermarket Left	132
FBS101IR	Pedestrian Access	Half Turnstile Supermarket Right	132
FDSC	Fencing	Detection System Router	149
FDSS	Fencing	Detection System Sensor	149
FHS	Fencing	High Security Fencing	146
FLA001	Options & Access	Flashing Light	78
FLROLLER	Options & Access	Flanged Roller	79
FP26	Fencing	Palisade Fencing	143
FP27TC	Fencing	Premier Fencing	143
FPSD	Gate Swing	Premier Dual	42
FPSS	Gate Swing	Premier Single	42
FPSS01	Pedestrian Access	Premier Gate	138
FR26	Fencing	Redfern Fencing	144
FS2624	Fencing	Securamesh Fencing	145
FSR	Fencing	Sports Fencing	144

<b>Intro</b>	<b>2</b>
<b>Gates</b>	<b>14</b>
Track	20
Cantilever	30
Swing	40
Bi-fold	46
Boom	52
Options	76
General	82
<b>Barriers</b>	<b>94</b>
Blockers	100
Tyre Spikes	102
Pre-cast	106
Other	111
<b>Pedestrian</b>	<b>114</b>
Turnstiles	114
Gates & Doors	136
<b>Fencing</b>	<b>142</b>
<b>Code Index</b>	<b>153</b>

## Product Range > Product Code Index

☎ 1300 780 450

Code	Product Group	Details	Page
GALCERT	Options & Access	Gal Certificate to Australian Standard	76
GATEBUMP	Options & Access	Bump Strip	78
GATETIMER	Options & Access	Programmable Timer	77
GATETIMERCAL	Options & Access	Programmable Timer Calendar Base	77
GDROLLER	Options & Access	Guide Roller	79
GG501	Signage	Stop	83
GG502	Signage	No Entry	83
GG503	Signage	Give Way	83
GG504	Signage	Stop / Visitors Report	83
GG505	Signage	No Entry	83
GG506	Signage	Visitor Parking	83
GG507	Signage	Shared Zone	83
GG508	Signage	Visitor Parking	83
GG509	Signage	Blank	83
GHI	Pedestrian Access	Half Turnstile Manual Gate	133
GLGATE	Options & Access	Gate Infill Security Glass Panel	76
GSC01	Signage	Caution Automatic Gate	83
GSC02	Signage	Warning Rising Bollards	83
GSC03	Signage	Caution Do Not Tailgate	83
GSC04	Signage	Caution Do Not Tailgate	83
GSC05	Signage	Caution / One Vehicle at a Time	83
GSC06	Signage	Caution Stop After Hours Exit	83
GSC07	Signage	Warning Stop	83
GSC08	Signage	Caution Pedestrians Must Not Use	83
GSC09	Signage	Caution Pedestrians Must Use	83
GSC10	Signage	Danger Keep Out	83
GSC11	Signage	Caution Automatic Gate	83
GSE01	Signage	Entry Down	84
GSE02	Signage	Entry Up	84
GSE03	Signage	Entry Left	84
GSE04	Signage	Entry Right	84
GSE05	Signage	Entry Only	84
GSE06	Signage	Exit Down	84
GSE07	Signage	Exit Up	84
GSE08	Signage	Exit Left	84
GSE09	Signage	Exit Right	84
GSE10	Signage	Exit Only	84
GSE11	Signage	Keep Left	84
GSE12	Signage	Keep Right	84
GSE13	Signage	One Way Left	84
GSE14	Signage	One Way Right	84
GSE15	Signage	One Way Do Not Enter	84
GSM1	Options & Access	GSM Gate Kit	77
GSM3	Options & Access	GSM Intercom Kit	77
GSS01	Signage	Speed Limit 5	84
GSS02	Signage	Speed Limit 10	84

Code	Product Group	Details	Page
GSS03	Signage	Speed Limit 15	84
GSS04	Signage	Speed Limit 20	84
GSS05	Signage	Speed Limit 25	84
GSW01	Signage	No Vehicles Beyond This Point	84
GSW02	Signage	No Stopping At Any Time	84
GSW03	Signage	Company Vehicles Only	84
GSW04	Signage	Authorised Vehicles Only	84
GSW05	Signage	Do Not Block Gate	84
HBDT	Gate Track Option	Heavy Bolt-Down Track	28
HCIT	Gate Track Option	Heavy Cast-In Track	28
HGIS40	Gate Cantilever	DIY Gate Installer Kit	34
HR90F/B	Vehicle Barriers	Steel Guard Susp Height Rail & Frame	113
HTFLI120D	Pedestrian Access	Half Turnstile Titan Industrial Dual	129
HTFLI120S	Pedestrian Access	Half Turnstile Titan Industrial Single	129
HUMPMS	Vehicle Barriers	Mild Steel Speed Hump	78 / 111
ICL	Gate Cantilever	Industrial	32
ICLU	Gate Cantilever	Industrial Undercarriage	33
ICLUS	Gate Cantilever	Security Undercarriage	33
IDSG	Gate Boom	Swing Industrial Dual	69
IHDGATE	Options & Access	Heavy Duty Wet Spray Finish	76
IMSG	Gate Boom	Swing Industrial Single	69
IPCGATE	Options & Access	Industrial Gate Powder Coated Finish	76
ISD	Gate Swing	Industrial Standard Dual	44
ISDGATE	Options & Access	Industrial Gate Std Duty Wet Spray	76
ISS	Gate Swing	Industrial Standard Single	44
ISTD	Options & Access	Surface Mounted Vehicle Detector	78
ITS	Gate Track	Industrial Full Height	23
ITSH	Gate Track	Industrial Half Height	23
ITSMBA	Gate Boom	Sliding Industrial Automatic	73
ITSMBA BS	Gate Boom	Sliding Boom Boom Shroud	75
KS	Options & Access	Key Switch Controller	77
LGCC	Options & Access	Standard Gate Control Cabinet	79
LGDAMP	Options & Access	Gate Damper	79
LGBSF	Options & Access	Industrial Gate Bi-Slide Kit	79
LGIBSI	Options & Access	Industrial Gate Bi-Slide Kit Per Metre	79
LGR	Options & Access	Additional Gate Raking Charge	79
LGSBSF	Options & Access	Security Gate Bi-Slide Kit Per Metre	79
LIF25	Fencing	High Security Impact Fencing	147
LIF35	Fencing	High Security Impact Fencing	147
LMC	Gate Cantilever	DIY Kit Gate	35
LOOPCAR	Options & Access	Road Loop Smaller Vehicles	78
LOOPDECT	Options & Access	Single Channel Loop Detector	78
LOOPTRUCK	Options & Access	Road Loop Truck	78
LTLLED1	Options & Access	LED Traffic Light x 1	78
LTLLED2	Options & Access	LED Traffic Light x 2	78
LTLLED3	Options & Access	LED Traffic Light x 3	78

1300 780 450

Code	Product Group	Details	Page
MBG	Gate Boom	Vertical Advantage Manual	67
MBGS	Gate Boom	Vertical Security Manual	67
MESHGATE	Options & Access	Gate Infill Steel Mesh	76
MIDTEIR	Options & Access	Mid Tier Slide Gate Auto	77
MNB33580	Gate Boom	Vertical High Security Manual	66
MNB37548	Gate Boom	Vertical High Security Manual	66
MNB47548	Gate Boom	Vertical High Security Manual	66
MSG	Gate Boom	Swing Advantage Single	68
NLROLLER	Options & Access	Nylon Roller	79
PALGAE	Options & Access	Gate Infill Palisade Pickets	76
PB	Options & Access	Push Button Controller	77
PBI450F/B	Vehicle Barriers	Steel Barrier 1.45m	112
PBI585F/B	Vehicle Barriers	Steel Barrier 1.0m	112
PB30F/B	Vehicle Barriers	Steel Barrier 3.0m	112
PB975F/B	Vehicle Barriers	Steel Barrier 0.78m	112
PBEMERG	Options & Access	Emergency Gate Release Kit	77
PCBI800A	Vehicle Barriers	Pre-cast Rectangular Planter	110
PCBI800B	Vehicle Barriers	Pre-cast Rectangular Planter	110
PCBH11A	Vehicle Barriers	Pre-cast Hercules Standard	109
PCBH11B	Vehicle Barriers	Pre-cast Hercules Locking Pins	109
PCBS20A	Vehicle Barriers	Pre-cast Samson Standard	109
PCBS20B	Vehicle Barriers	Pre-cast Samson Locking Pins	109
PCHJ3	Vehicle Barriers	Pre-cast Jersey Half-Sided 3m	108
PCHJ6	Vehicle Barriers	Pre-cast Jersey Half-sided 6m	108
PCJ3	Vehicle Barriers	Pre-cast Jersey Standard 3m	108
PCJ3CD	Vehicle Barriers	Pre-cast Jersey Drainage 3m	108
PCJ3M/F	Vehicle Barriers	Pre-cast Jersey End Unit 3m	108
PCJ6	Vehicle Barriers	Pre-cast Jersey Standard 6m	108
PCJ6CD	Vehicle Barriers	Pre-cast Jersey Drainage 6m	108
PCL205F	Vehicle Barriers	Pre-cast Solid Log	110
PCL55F	Vehicle Barriers	Pre-cast Solid Cube	110
PEBEAM	Gate Boom	Safety Beam	60
PEBEAMARRAY	Options & Access	Photo Electric Beam Light Array	78
PEBEAMGRID	Options & Access	Photo Electric Light Grid	78
PEBEAMLZR	Options & Access	Programmable Laser Beam Curtain	78
PEBEAMX	Gate Boom	Safety Beam Extension	60
PEMEANI	Options & Access	PE Beam Single Point	78
PEMEAN2	Options & Access	PE Beam Single Point to Point	78
PESHROUD	Options & Access	PE Beam Protective Shroud	78
PGDB32	Options & Access	Key Locking Drop Bolt	80
PIN	Options & Access	Pin Code Pad	77
PL400L	Options & Access	24V Universal Interface	77
PLROLLER	Options & Access	Plain Roller	79
PROX	Options & Access	Proximity Card	77
PRSS	Pedestrian Access	Industrial Redfern Gate	138
PSWS	Pedestrian Access	Security Gate	139

Code	Product Group	Details	Page
PSWS1010	Pedestrian Access	Half Turnstile Manual Gate	133
PSWSC	Pedestrian Access	Security Gate Overhead Rail	139
PVCBAS	Gate Boom	PVC Boom Arm	60
RBI	Vehicle Barriers	Road Barrier	96
RBI414	Vehicle Barriers	Road Blocker Surface Mount	100
RB3014	Vehicle Barriers	Road Blocker Surface Mount	100
RECHM	Fencing	Rubbish Enclosure Chain Mesh Panel	152
REMOTE1	Options & Access	Remote Control	77
REMOTE2	Options & Access	Remote, Reporting	77
REMOTE3	Options & Access	Remote, Laptop, Reporting	77
RESGM	Fencing	Rubbish Enclosure Square Mesh Panel	152
RESIP	Fencing	Rubbish Enclosure Solid Panel	152
RG21	Fencing	Retractable Gate	151
RMG50	Vehicle Barriers	Retractable Gate Manual	99
RPGS	Pedestrian Access	Industrial RAAF Gate	139
RSD	Gate Swing	Industrial Redfern Dual	43
RSS	Gate Swing	Industrial Redfern Single	43
RTFBI120	Pedestrian Access	Full Turnstile Relocatable 0.9m Bar	118
RTS	Gate Track	Industrial Redfern	24
SBRI20B	Pedestrian Access	Turnstile (HTFLI 120) SS Guide Rail	129
SBTFBI120	Pedestrian Access	Bicycle Entry Turnstile 0.9m Bar SS	120
SC	Options & Access	Security Column Receiving Post	79
SCIT60	Gate Track Option	Standard Cast-In Track	28
SDHP04	Pedestrian Access	Security Door Horizontal Pickets	141
SDMC05	Pedestrian Access	Security Door Metal Cladding	141
SDVP01	Pedestrian Access	Security Door Vert Pickets	141
SDVP02	Pedestrian Access	Security Door Vert Pickets / Bracing	141
SDVP03	Pedestrian Access	Security Door Vert Pickets / Bracing	141
SFBS0611L	Pedestrian Access	Half Turnstile Swing Barrier Left	131
SFBS0611R	Pedestrian Access	Half Turnstile Swing Barrier Right	131
SFBS0911L	Pedestrian Access	Half Turnstile Swing Barrier Left	131
SFBS0911R	Pedestrian Access	Half Turnstile Swing Barrier Right	131
SFBS1011L	Pedestrian Access	Half Turnstile Supermarket Left SS	132
SFBS1011R	Pedestrian Access	Half Turnstile Supermarket Right SS	132
SHCP20	Options & Access	Stainless Steel Hinged Cover Plate	80
SHDGATE	Options & Access	Security Gate HDuty Wet Spray Finish	76
SHTFLI120	Pedestrian Access	Half Turnstile Titan Industrial Stainless	129
SHUMPASPH	Vehicle Barriers	Speed Hump	78 / 111
SIREN	Options & Access	Siren	78
SIRENB	Options & Access	Flashing Light and Siren	78
SK010D	Gate Boom	Swing Security Dual	70
SK010S	Gate Boom	Swing Security Single	70
SOLAR	Options & Access	Solar Power	77
SOLARB	Options & Access	Solar Power for Track Gates	77
SOLARG	Options & Access	Solar Power for Track Gates	77
SOLART	Options & Access	Solar Power for Turnstiles	77

<b>Intro</b>	<b>2</b>
<b>Gates</b>	<b>14</b>
Track	20
Cantilever	30
Swing	40
Bi-fold	46
Boom	52
Options	76
General	82
<b>Barriers</b>	<b>94</b>
Blockers	100
Tyre Spikes	102
Pre-cast	106
Other	111
<b>Pedestrian</b>	<b>114</b>
Turnstiles	114
Gates & Doors	136
<b>Fencing</b>	<b>142</b>
<b>Code Index</b>	<b>153</b>



## Product Range > Product Code Index

1300 780 450

Code	Product Group	Details	Page
SP40F	Signage	Galvanised Pipe Post	83
SPCGATE	Options & Access	Security Gate Powder Coated Finish	76
SPDT55	Gate Track Option	Standard Pin-Down Track	28
SSDGATE	Options & Access	Security Gate Std Duty Wet Finish	76
SSG20L	Pedestrian Access	Half Turnstile Stainless Left	131
SSG20R	Pedestrian Access	Half Turnstile Stainless Right	131
SSPOD	Gate Swing	Industrial Sports Dual	43
SSPOS	Gate Swing	Industrial Sports Single	43
STANDARD	Options & Access	Gate Infill Square Pickets	76
STF2R	Pedestrian Access	Full Turnstile Polycarb Round	125
STF3S	Pedestrian Access	Full Turnstile Polycarb Decagonal	125
STFB1120	Pedestrian Access	Full Turnstile 0.9m Bar Stainless	116
STFB2120	Pedestrian Access	Full Turnstile 1.2m Bar Stainless	117
STFBD1120	Pedestrian Access	Full Turnstile Dble 0.9m Bar SS	119
STFBDP1120	Pedestrian Access	Full Turnstile Dble Security Ped Gate	123
STFL1120	Pedestrian Access	Full Turnstile Loop 0.9m Bar SS	121
STFLD1120	Pedestrian Access	Full Turnstile Dble Loop 0.9m Bar SS	121
STFLDP1120	Pedestrian Access	Full Turnstile Dble Sec Ped Gate Loop	123
STHI	Pedestrian Access	Half Turnstile Stainless	130
STHSG1I	Pedestrian Access	Half Turnstile Stainless Intermediate	130
STHSG1L	Pedestrian Access	Half Turnstile Stainless Left	130
STHSG1R	Pedestrian Access	Half Turnstile Stainless Right	130
SW12	Vehicle Barriers	Road Blocker Shallow Mount	101
SWD	Gate Swing	Security Dual	44
SWS	Gate Swing	Security Single	44
SWSV	Gate Swing	High Security V Gate	45
TB	Options & Access	Gate Top Extension Barbed Wire	76
TC	Options & Access	Gate Top Extension Crimped Picket	76
TF	Options & Access	Gate Top Extension Flat Picket	76
TFB1120	Pedestrian Access	Full Turnstile 0.9m Bar	116
TFB1120C	Pedestrian Access	Full Turnstile 0.9m Bar Cyclone Rated	116
TFB2120	Pedestrian Access	Full Turnstile 1.2m Bar	117
TFBD1120	Pedestrian Access	Full Turnstile Double 0.9m Bar	119
TFBDP1120	Pedestrian Access	Full Turnstile Ped Gate 0.9m Bar	122
TFL1120	Pedestrian Access	Full Turnstile Looped 0.9m Bar	121
TFLD1120	Pedestrian Access	Full Turnstile Loop Double 0.9m Bar	121
TFLDP1120	Pedestrian Access	Full Turnstile Loop Ped Gate 0.9m Bar	122
TH	Options & Access	Gate Top Extension Shark Tooth	76
THI	Pedestrian Access	Half Turnstile	130
THLED	Gate Boom	LED Boom Lights	60
THS30A	Gate Boom	Vert Ind High Speed Articulated Boom	59
THS30S	Gate Boom	Vert Ind High Speed Standard Boom	59
TL900	Pedestrian Access	Half Turnstile Sliding Door	134
TL900H	Pedestrian Access	Half Turnstile Sliding Door	134
TL900HL	Pedestrian Access	Half Turnstile Sliding Door	134
TL900HLW	Pedestrian Access	Half Turnstile Sliding Door	134

Code	Product Group	Details	Page
TL900HW	Pedestrian Access	Half Turnstile Sliding Door	134
TL900LW	Pedestrian Access	Half Turnstile Sliding Door	134
TL900W	Pedestrian Access	Half Turnstile Sliding Door	134
TL901S	Pedestrian Access	Half Turnstile Sliding Door	135
TL901W	Pedestrian Access	Half Turnstile Sliding Door	135
TMFA	Gate Boom	Vertical Boom Articulated Arm	56
TMH120	Gate Boom	Vertical Industrial Automatic	57
TMH3024	Gate Boom	Vertical Industrial Automatic 24V	58
TMH5024	Gate Boom	Vertical Industrial Automatic 24V	58
TMH60	Gate Boom	Vertical Industrial Automatic	56
TMH80	Gate Boom	Vertical Industrial Automatic	57
TMH80CW	Gate Boom	Vert Ind Auto, Supports, C'weight	57
TMH80S	Gate Boom	Vertical Industrial Automatic with Skirt	57
TMHP39	Gate Boom	Vertical Industrial Portable	58
TMS	Gate Track	Security	25
TMSBA	Gate Boom	Sliding Security Automatic	73
TMSBAH	Gate Boom	Sliding High Security Automatic	74
TMSBAXH	Gate Boom	Sliding High Security Automatic	74
TMSH	Gate Track	High Security	25
TMSH3	Gate Track	High Security	26
TMSK02	Gate Boom	Vertical Boom Skirt	56
TOPTIER	Options & Access	Top Tier Slide Gate Auto	77
TP	Options & Access	Gate Top Extension Palisade Picket	76
TR	Options & Access	Gate Top Extension Razor Wire	76
TR00F1	Pedestrian Access	Turnstile Roof	126
TR00F2	Pedestrian Access	Turnstile Roof	126
TR00F3	Pedestrian Access	Turnstile Roof	126
TS8300 SIL	Options & Access	Dorma Automatic Door Closer	80
TSA20	Vehicle Barriers	Tyre Spike Auto In Ground	105
TSM10	Vehicle Barriers	Tyre Spike Manual Surface Mount	103
TSM10IG	Vehicle Barriers	Tyre Spike Manual In Ground	103
TSMBA BS	Gate Boom	Sliding Boom Boom Shroud	75
TWS	Vehicle Barriers	Pre-cast Truck Stop 1.5m	111
UPS	Options & Access	Uninterrupted Power Supply	77
VBB	Vehicle Barriers	Barrier Bar	97
VG01	Gate Bi-Fold	High Security Trackless Single Sided	51
VHDRT	Gate Track Option	Very Heavy Duty Rail Track	28
WS16	Vehicle Barriers	Pre-cast Car Stop 1.6m	111
WS20	Vehicle Barriers	Pre-cast Car Stop 2.0m	111
WSR16	Vehicle Barriers	Rubber Car Stop 1.6m	111
WSR20	Vehicle Barriers	Rubber Car Stop 2.0m	111
ZINCGATE	Options & Access	Gate Infill Zinalume Steel	76



Where no standard exists, Leda Product Handbooks are normally considered industry standard.

Leda Handbooks not only display the updated and expanded range of products but are also informative reference guides for any security library.



Architectural & Security Bollards Handbook



Bicycle Parking & Security Handbook



Copyright © Leda Security Products Pty Ltd 2013.  
Product specifications displayed in this Handbook are accurate at time of printing.  
Improvements and additions are continually being made to the product range.  
Check with your nearest Leda Sales office that the designs and specifications displayed are still current. Comprehensive brochures and technical literature on the complete range of Leda's architectural and security products are available on request or visit the website: [www.ledasecurity.com.au](http://www.ledasecurity.com.au).



Doors & Loading Dock Product Handbook



**Leda Security Products Pty Ltd**  
ABN 23 067 258 235

**Telephone 1300 780 450**  
**Email [sales@ledasecurity.com.au](mailto:sales@ledasecurity.com.au)**

**NSW Sales**

Unit 8 / 185 Briens Rd  
Northmead NSW 2152  
PO Box 128  
Wentworthville NSW 2145  
Phone: 02 8413 3410  
Fax: 02 8677 7119

**VIC Sales**

Unit 2 / 89 Enterprise Way  
Sunshine West VIC 3020  
PO Box 1091  
Sunshine West VIC 3020  
Phone: 03 8399 8150  
Fax: 03 9315 1085

**QLD Sales**

Unit 2 / 387 Lytton Rd  
Morningside QLD 4170  
PO Box 186  
Morningside QLD 4170  
Phone: 07 3613 8270  
Fax: 07 3399 5688

**SA Sales**

Unit 1 / 5 Tooronga Ave  
Edwardstown SA 5039  
Phone: 08 8374 3266  
Fax: 08 8374 3299

**WA Sales**

Unit 1 / 3 Finance Place  
Malaga WA 6090  
Phone: 08 6430 1670  
Fax: 08 9209 2860

**Head Office**

**& Manufacturing**  
18 Reliance Drive  
Tuggerah NSW 2259  
PO Box 5196  
Chittaway Bay NSW 2261  
Australia  
Phone: +61 2 8413 3430  
Fax: +61 2 4353 2255

*Australasian distributors and resellers in Northern Territory, north Queensland, Tasmania and New Zealand.*

---

**Distributed by**