

COMPRESSED

FLOORING SUBSTRATE



HISTORY & MISSION



Our distribution network ensures that our entire product range is readily available in all states of Australia and in New Zealand.

In keeping with our mission, we are constantly assessing and improving our products to ensure that we always provide cost effective, high quality and easy-to-use products to the market.

CONTENTS



5 // PRODUCT DESCRIPTION	7 // CONCENTRATED LOADS	
5 // PRODUCT INFORMATION	7 // UNIFORMLY DISTRIBUTED LOADS	
5 // FIRE RESISTANCE	8 // WET AREA TILED FLOORS	
5 // SHEET PROPERTIES	8 // GENERAL	
5 // SHEET TOLERANCES	8 // FRAMING	13 // LIGHTWEIGHT STEEL FRAMING
5 // SIZE AND WEIGHT	8 // SHEET JOINTS	13 // SHEET PREPARATION
6 // HANDLING AND STORAGE	8 // FLOOR DRAINAGE	13 // SEALING
6 // QUALITY SYSTEMS	10 // SHOWER RECESSES	13 // RAISED DECKS: HABITABLE AREA BELOW
6 // CUTTING AND DRILLING	11 // INTERIOR TILED FLOORS	13 // SHEET MEMBRANE
6 // HOLES	12 // EXTERIOR DECKING	13 // SLIP SHEET
6 // HEALTH AND SAFETY	12 // GENERAL REQUIREMENTS	15 // SHEET LAYOUT
6 // AVOID INHALING DUST	12 // FRAMING	15 // LOW LEVEL DECK
7 // CONCENTRATED AND UNIFORMLY DISTRIBUTED LOADS	12 // FIXING	15 // WARRANTY
	13 // TIMBER FRAMING	

COMPRESSED

FLOORING SUBSTRATE



HIGH-DENSITY COMPRESSED FLOORING IS A SUPERLATIVE SUBSTRATE FOR INTERIOR FLOORS IN FRAMED CONSTRUCTION WET AREAS. FINE FOR UPPER STORIES AND TRANSPORTABLE BUILDINGS, IT'S EQUALLY SUITED FOR USE AS A SUBSTRATE FOR EXTERIOR DECKS.

COMPRESSED FLOORING IS MANUFACTURED FROM PORTLAND CEMENT, FINELY-GROUND SILICA, CELLULOSE FIBRES AND WATER. AFTER FORMING, WE COMPRESS THE SHEETING TO HIGH DENSITY, THEN CURE IT IN A HIGH-PRESSURE STEAM AUTOCLAVE FOR AN EXCEPTIONALLY DURABLE, FIT-FOR-PURPOSE PRODUCT.

COMPRESSED FLOORING

- // Immune to permanent water damage
- // Impact-resistant and immune to termite attacks
- // Highly durable and dimensionally stable
- // Suitable for wet areas and for cladding external decking
- // Easy to work

PRODUCT DESCRIPTION

Compressed Flooring is a high density fibre cement sheet which is ideally suited as a structural substrate or interior floors in wet areas or ramed constructions; including upper stories and transportable buildings.

It is equally suited for use in the cladding of exterior decks.

PRODUCT INFORMATION

Compressed Flooring is manufactured from Portland cement, finely ground silica, cellulose fibers and water. After forming it is compressed to a high density then cured in a high-pressure steam autoclave to create a durable, dimensionally stable product.

Compressed Flooring is immune to permanent damage from water. It is impact resistant, immune to termite attack and easy to work.

Compressed Flooring is manufactured to conform to the requirements of AS2908 Cellulose Cement Products, and is classified as Type A Category 5 for exterior use.

SHEET PROPERTIES

Property	at EMC*
Density	1700 kg/m ³
Modulus of Elasticity	10 GPa
Thermal Expansion Co-Efficient	10 x 10 ⁻⁶ /k0 (est. average)
Moisture Movement - from EMC* to saturated	Approx. 700 Microstrains (expansion)
- from 30 to 90% RH	Approx. 500 Microstrains (expansion)

NOTE: The environmental conditions for *Equilibrium Moisture Content (EMC) values is nominally 23°C and 50% relative humidity.

FIRE RESISTANCE

Compressed Flooring is deemed non-combustible and may be used where a non-combustible material is required in accordance with C2D10 and H3D2 of the BCA.

When tested in accordance with Australian Standard AS 1530.3 the Early Fire Hazard Indices are as follows:

// Ignitability Index 0
 // Spread of Flame Index 0
 // Heat Evolved Index 0
 // Smoke Developed Index 0 – 1

SHEET TOLERANCES

// Width +0/-1mm
 // Length +0/-2mm
 // Thickness +10%/-0%
 // Diagonals difference (max) 2mm
 // Edge straightness deviation (max) 1mm
 // R Value (approx.) 0.08

SIZE AND WEIGHT

Thickness mm	Weight kg/m ²	Width mm	Length mm					
			1500	1800	2100	2400	2700	3000
15	26	900	✓	✓	✓	✓	✓	✓
		1200	✓	✓	✓	✓	✓	✓
18	31.1	900	✓	✓		✓		✓
		1200	✓	✓	✓	✓		✓
24	41.2	1200				✓		

Weights are based on Equilibrium Moisture Content.

HANDLING AND STORAGE

Compressed Flooring must be stacked flat, up off the ground and supported on equally spaced level bearers at 450mm centres.

Compressed Flooring must be kept dry, preferably by being stored inside a building. When stored outdoors it must be protected from the weather.

Care should be taken to avoid damage to the ends, edges and surfaces.

Compressed Flooring must be dry prior to fixing, jointing or finishing.

QUALITY SYSTEMS

Innova Fibre Cement manufactures Compressed Flooring under the rigorous Quality Management System of the International Standard ISO 9001:2008, and is the holder of Licence Agreement number QEC2955/13.

CUTTING AND DRILLING

Compressed Flooring can be cut to size on site.

Because of the high density of Compressed Flooring either Tungsten Carbide or Diamond tipped tools are generally required.

For straight cuts, Innova recommend the use of a Durablade fitted to a 185mm circular saw, with a full dust extraction system.

HOLES

For small holes a well-sharpened Tungsten Carbide Masonry drill is recommended. Use a slow drill speed.

Do not use the drills hammer function.

For larger circular holes such as waste holes a Tungsten Carbide or Diamond tipped hole saw is recommended.

Alternatively drill a series of small holes around the perimeter of the cut out, and then gently tap out the waste piece while supporting the underside of the opening to avoid damage. Clean up any rough edges with a rasp.

HEALTH AND SAFETY

Compressed Flooring is manufactured from cellulose fibre, finely ground sand, Portland cement and additives. As manufactured the product will not release airborne dust, but during drilling, cutting and sanding operations cellulose fibres, silica and calcium silicate dust may be released.

Breathing in fine silica dust is hazardous, prolonged exposure (usually over several years) may cause bronchitis, silicosis or cancer.

AVOID INHALING DUST

When cutting sheets, work in a well-ventilated area and use the methods recommended in this literature to minimise dust generation.

If using power tools for cutting drilling or sanding they must be fitted with appropriate dust collection devices or alternatively use an approved (P1 or P2) dust mask and wear safety glasses.

These precautions are not necessary when stacking, unloading or handling fibre cement products.

For further information or a Material Safety Data Sheet contact the nearest Innova Sales Office.

CONCENTRATED AND UNIFORMLY DISTRIBUTED LOADS

The BCA (Building Code of Australia) specifies that all floor structures be designed in accordance with AS1170.1-2002 'Structural design actions: Part 1 - Permanent, imposed and other actions'.

This standard specifies the loading conditions that the floor must be able to sustain. All dead and live loads that a floor is subjected to must be combined and factored in accordance with AS1170.0-2002 'Structural design actions: Part 0 - General principles'.

CONCENTRATED LOADS

Table 1 shows that Compressed Flooring is suitable for these loads and should be used to determine the thickness of Innova Compressed Flooring required based on the application it is to be used for.

AS1170.1 distinguishes between residential and commercial flooring applications with point loads that each application must be designed to withstand.

Table 3.1 of AS1170.1 gives the minimum concentrated loads that must be sustained for each application. For residential and domestic applications the floor must sustain a 1.8kN (~180kg) load over an area of 350mm². This is equal to a 21.1mm diameter round or 18.71mm square annulus. Innova Compressed Flooring can sustain this load.

Other residential and indoor commercial applications, AS1170.1 requires higher concentrated loads of: 2.7kN, 3.5kN and 4.5kN depending on the application of the floor. These concentrated loads must be exerted over an area of not more than 0.01m², which is equivalent to a 100mm x 100mm applicator.

Table 1

Thickness (mm)	Concentrated Load (kN)	Joist Spacing (mm)
15	2.5	300-600
18	4.1	300-600
24	7.8	300-600

UNIFORMLY DISTRIBUTED LOADS

Tables 2a and 2b show the maximum allowable uniformly distributed load for Innova Compressed Flooring thickness and the specified joist centres.

Table 2a

Span/joist spacing - Sheets perpendicular to joists

Thickness (mm)	Span/Joist Spacing						
	300	350	400	450	500	550	600
	kPa						
15	39.80	28.33	18.98	13.33*	9.72*	7.30*	5.65*
18	53.13	38.81	29.16	18.20*	11.94*	8.16*	5.76*
24	92.65	67.85	51.75	40.72	31.19	21.31*	15.04*

Table 2b

Span/joist spacing - Sheets parallel to joists

Thickness (mm)	Span/Joist Spacing						
	300	350	400	450	500	550	600
	kPa						
15	27.95	20.32	15.36	11.97	9.54	7.30*	5.62*
18	36.35	26.49	20.09	15.7	11.94*	8.16*	5.76*
24	68.32	49.97	38.07	29.9	24.06	19.74	15.04*

* UDL as indicated is limited by deflection

Notes

Applications that require a point load capacity greater than 1.8kN will require trimmers to support all edges of each floor sheet. A deflection limit of span/200 has not been exceeded under serviceability load conditions. Loads specified in the tables are working loads and need to be factored in accordance with AS1170 to determine ultimate loads. Uniformly distributed loads specified include 1kpa to account for floor coverings and partitions etc. These values apply to the dry and fully saturated state. Orientation of the sheets length across joists is preferred; Parallel orientation requires all sheet edges to be supported in all instances.

WET AREA TILED FLOORS

Compressed Flooring is ideally suited as a substrate for ceramic tiled floors in the wet areas such as bathrooms and laundries.

GENERAL

Satisfactory performance of wet area systems depends on strict adherence to the Building Code of Australia and the Australian Standard AS 3740-2010 "Waterproofing of wet areas within residential buildings" and AS 4654.2-2009 "Waterproofing membrane systems for exterior use – above ground level".

FRAMING

Compressed Flooring can be fixed to either timber or lightweight steel framing.

Timber framing must comply with AS 1684 "Residential Timber Frame Construction". Unseasoned timber must not be used.

Metal framing must comply with AS3623 "Domestic Metal Framing".

Floor joists are required as follows:

INNOVA COMPRESSED FIBRE CEMENT FLOORING SHEET THICKNESS (MM)	MAXIMUM JOIST CENTRES (MM)
15	450
18	600
24	600

Innova recommend sheets to be laid with the long edge across the joists. (Figure 2)

When sheets are laid with the long edge parallel to the joists; trimmers must be added so that all sheet edges and joints are supported.

In all cases a floor joist or trimmer must support the sheet end.

SHEET JOINTS

For interior applications sheet joints must be sealed using HydrEpoxy 501 or similar.

Thoroughly clean the edges to be joined using a wire brush. Butter the adhesive onto both edges and push together gently until the glue line thickness is 1mm (the edges of the board are separated by 1mm of adhesive). Do not fix adjacent sheets and then attempt to fill the joint in situ.

Hint: Placing a strip of masking tape along each sheet edge before jointing will reduce clean up. Removing the tape immediately after sealing will leave the area clear of sealant and scuffmarks.

FLOOR DRAINAGE

In wet areas lay mortar bed (screed) over the Compressed Flooring to produce a minimum 1:60 fall to the waste drain. Minimum screed thickness of 25mm.

Figure 1 depicts a typical floor waste installation showing the waterproof membrane carried down into the fitting. The inner pipe is slotted to allow drainage of the mortar bed (screed).

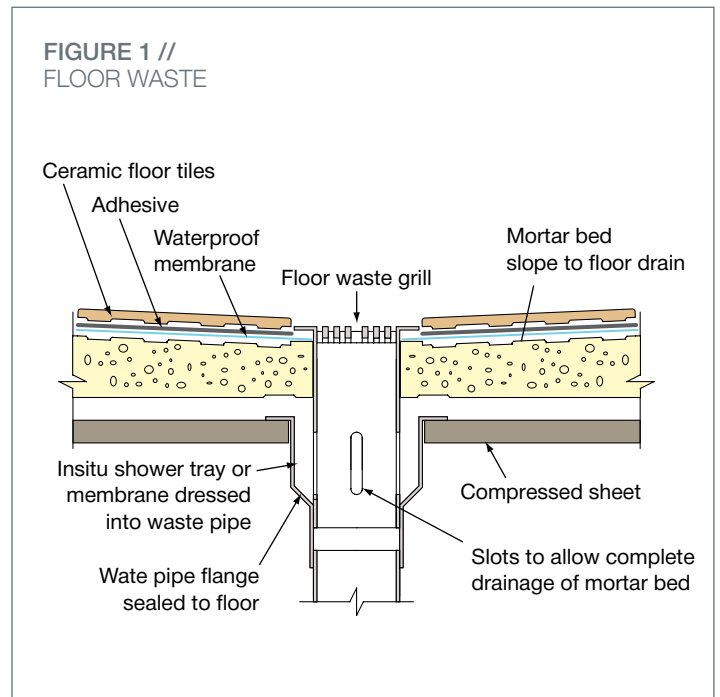
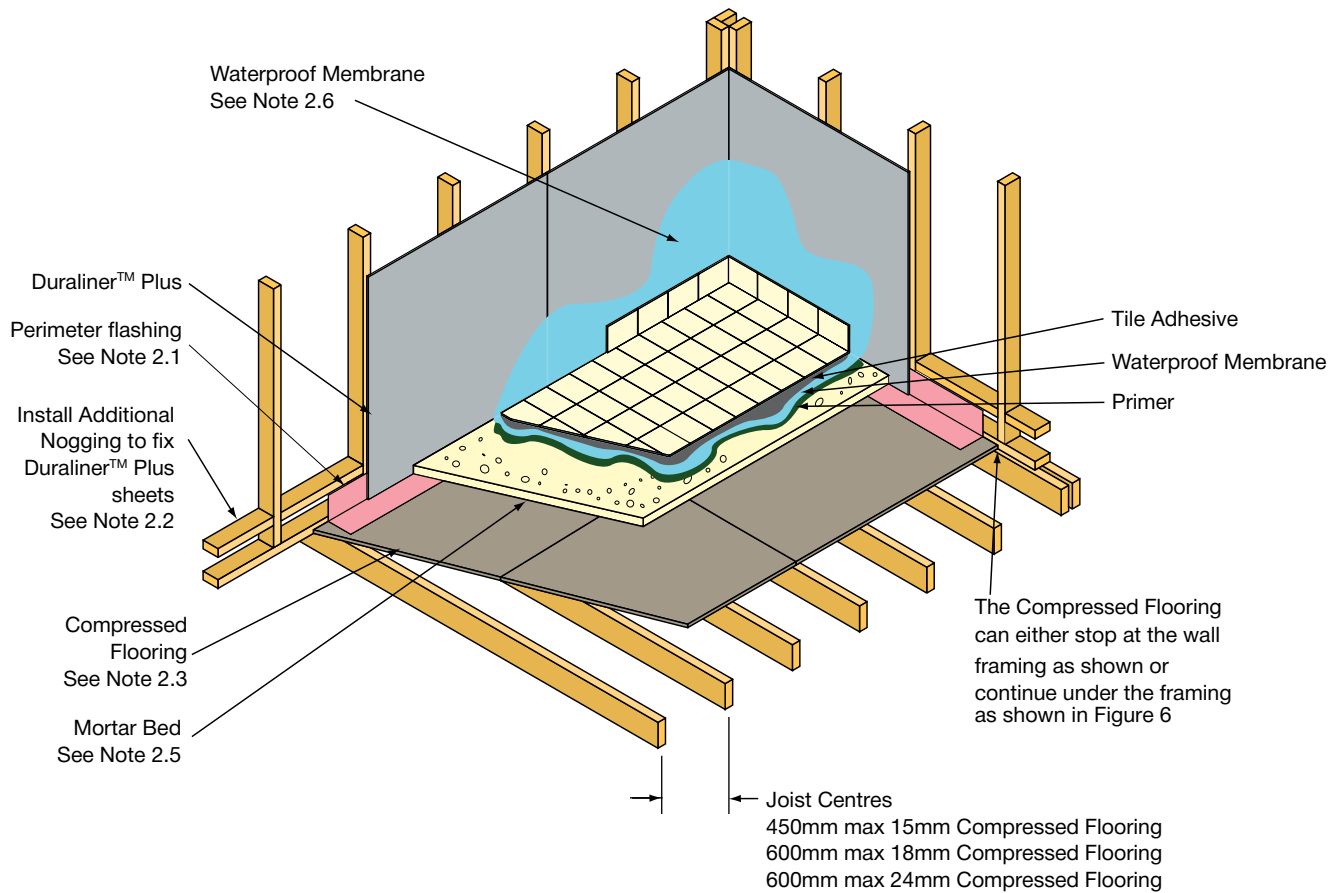

FIGURE 2 //
WET AREA - TYPICAL DETAIL
 Ensure all work complies with the BCA + AS3740



Note 2.1

Perimeter flashing or in situ membrane bonded to Innova Compressed Flooring, using a two-part flexible epoxy resin eg. HydrEpoxy 501 or equivalent.

The perimeter flashing may be a preformed PVC angle or a waterproof flashing strip such as Hypalon.

It must extend 150mm minimum up the wall and 50mm across the floor. The corner detail must be waterproof, as per AS 3740.

The flashing or membrane must not be bonded to the wall studs.

Note 2.2

An additional wall nogging must be installed so that the bottom of the Duraliner™ Plus is nailed above the flashing.

Note 2.3

The Compressed Flooring should be laid across the floor joists as shown.

All sheet joints must be sealed with HydrEpoxy 501, or similar.

Note 2.4

Lay waterproof membrane over compressed sheets at a minimum of 150mm upstand of the perimeter flashing, as per AS3740.

The membrane must be dressed into the floor waste.

Note 2.5

Lay a mortar bed (screed) over the Compressed Flooring to produce a 1:60 fall to the waste drain. Minimum screed thickness of 25mm.

Note 2.6

Shower walls are to be water resistant to 1800mm from finished floor level.

SHOWER RECESSES

Particular attention is required to the sealing of shower alcoves or recesses.

As with all wet area applications strict adherence to the Building Code of Australia, AS 3740-2010 and local building regulations is essential.

Two basic systems are presented to illustrate the general principals involved.

Figures 3&4 depict a preformed shower base. Figure 5 depicts a waterproof membrane, which may be either preformed or insitu.

FIGURE 3 //
SHOWER RECESS - TYPICAL DETAIL
Ensure all work complies with the BCA + AS3740

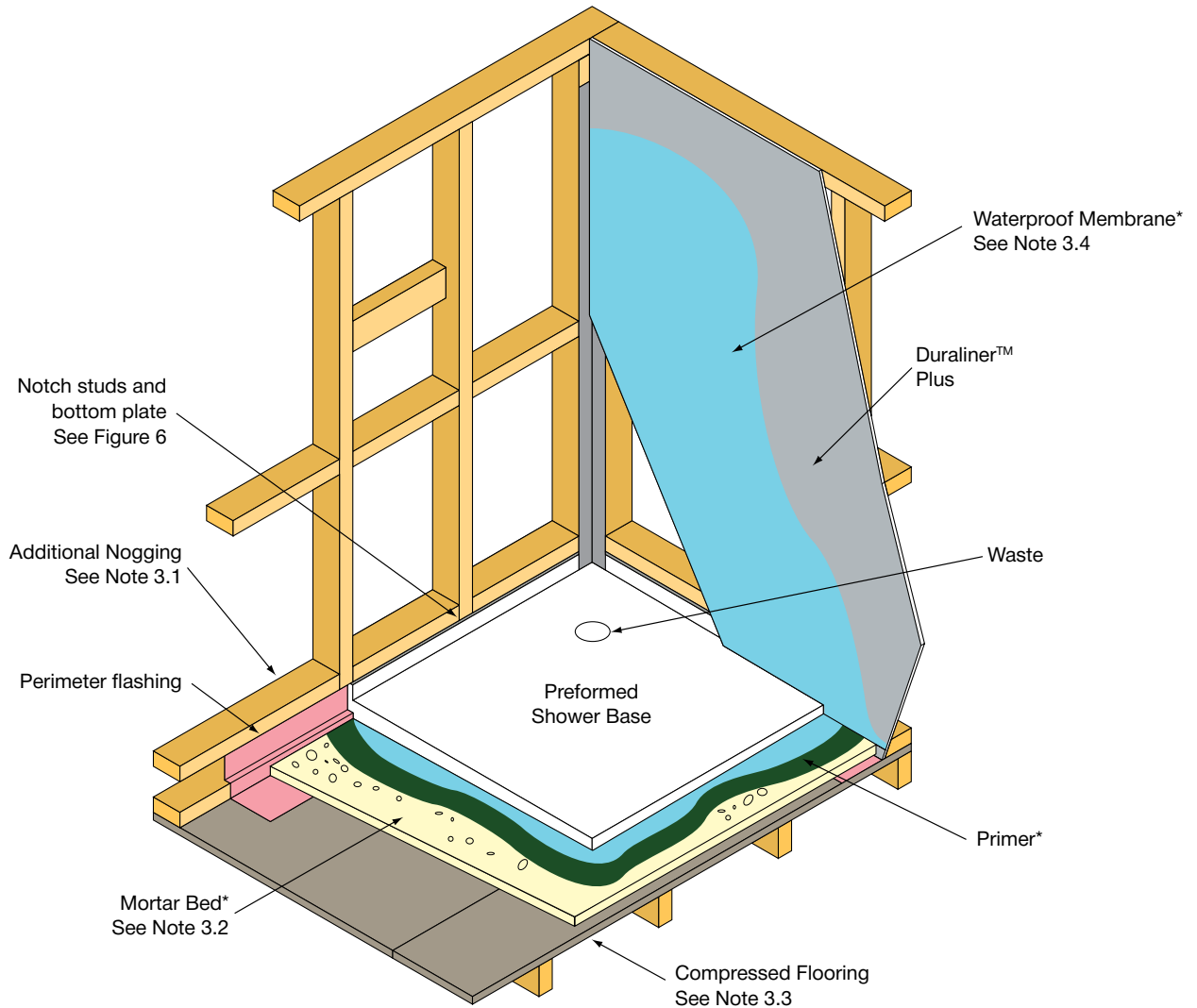

Note 3.1

A nogging is required 25mm above the top of the shower tray to nail the Duraliner™ Plus sheet to without penetrating the perimeter flashing.

Note 3.2

Lay a mortar bed over the Compressed Flooring to produce a 1:60 fall away from the shower base toward the waste drain.

Note 3.3

The Compressed Flooring are to be laid across the floor joists as shown.

All sheet joints must be sealed with HydrEpoxy 501 or equivalent.

Note 3.4

Shower walls are to be water resistant to 1800mm from finished floor level.

FIGURE 4 // PREFORMED SHOWER BASE

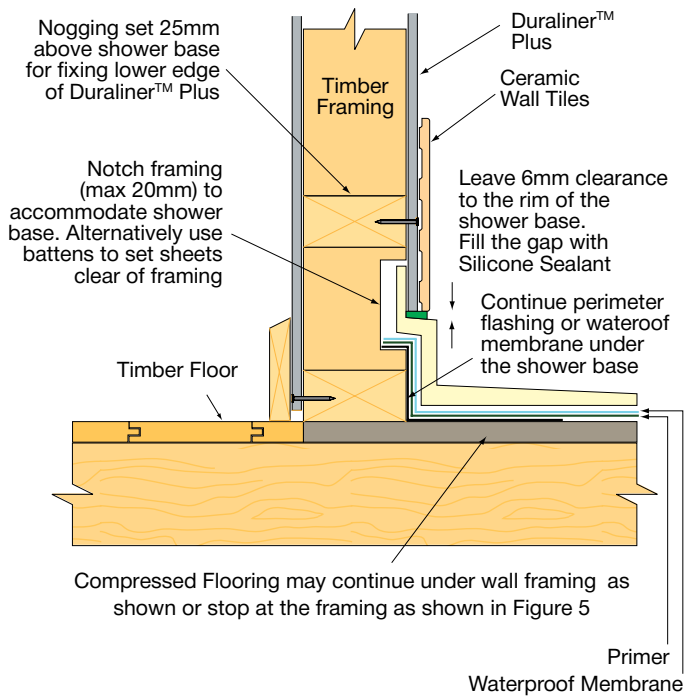

In areas where floor waste drains are not required, or example kitchens, ceramic floor tiles may be fixed directly to the Compressed Flooring.

Compressed Flooring should be laid across the floor joists. Use a proprietary tile adhesive conforming to the Australia Standards AS2358 – Adhesives – for fixing ceramic tiles and AS3958.1 – Ceramic tiles – Part 1 – Guide to the installation of ceramic tiles.

Thoroughly clean the edges to be joined using a wire brush. Butter the adhesive onto both edges and push together gently until the glue line thickness is 1mm (the edges of the board are separated by 1mm of adhesive). Do not fix adjacent sheets and then attempt to fill the joint in situ. **Ensure the tiles do not bridge the sheet joints.**

Do not fix adjacent sheets and then attempt to fill the joint in situ.

FIGURE 6 // TILES AND SHEET JOINTS

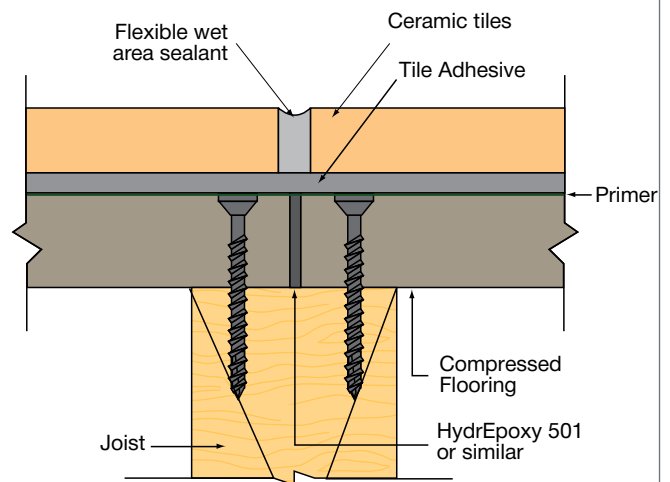

Expansion control joints are required when a continuous run of flooring exceeds 4.5 metres, at changes of direction, around the perimeter and at openings such as doorways. Control joints must continue through the Innova Compressed Flooring and the tiling.

FIGURE 5 // USING WATERPROOF MEMBRANE

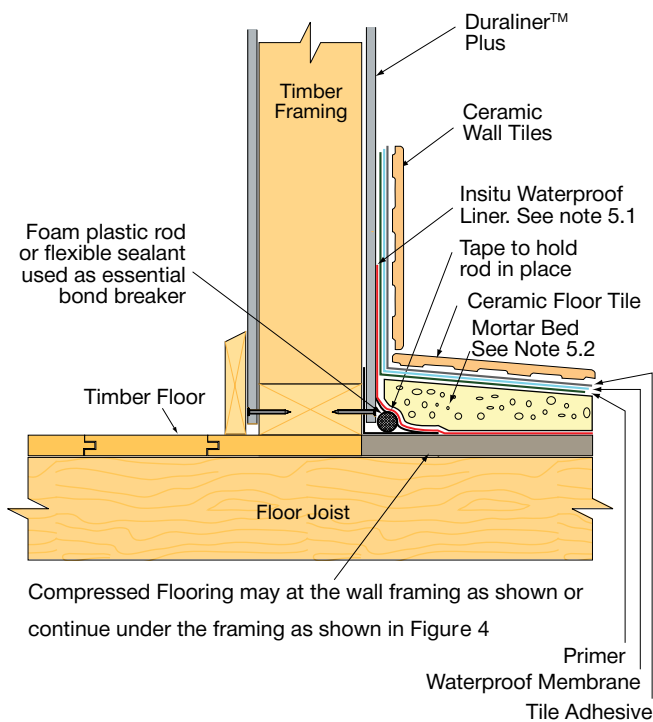

Note 5.1

The waterproof lining must extend 150mm min up the walls or 25mm above any hobs (whichever is greatest).

Note 5.2

Lay a mortar bed (screed) over the Innova Compressed Flooring to produce a 1:60 fall to the waste drain. Minimum screed thickness of 25mm.

FIGURE 7 // CONTROL JOINTS

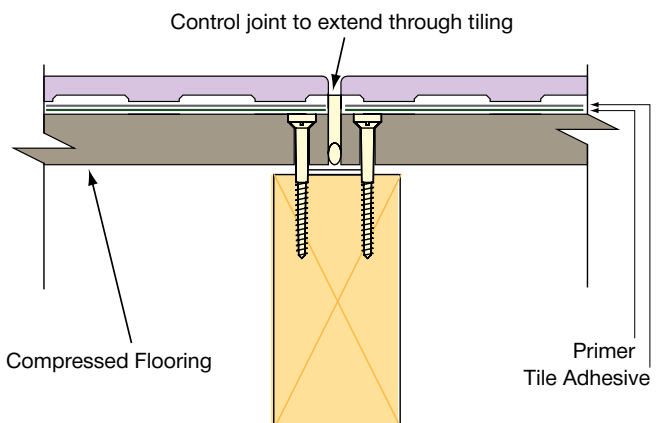

Areas subject to moisture and/or sunlight require a control and expansion joint at 2400-3600 max. centres.

EXTERIOR DECKING

Compressed Flooring can be used as the substrate for a variety of exterior decking applications such as above ground pool surrounds, verandas and sun decks.

The basic requirements of three systems are covered in this brochure.

GENERAL REQUIREMENTS

Installation of waterproofing membranes must be in accordance with AS 4654.2-2009 Waterproofing Membrane Systems for Exterior Use – Above ground level. Tile installation must be in accordance with AS3958.1-2007 Ceramic tiles – A Guide to the Installation of Ceramic Tiles.

All decks shall have a fall of at least 1:100 to an outside edge. The use of internal sumps in decking is not recommended.

A step down, of at least 50mm should be provided at any doorways onto the deck, as per AS 4654.2-2009.

Framing is required to support all sheet edges. The exception being the outer edge of decks with a drip mould is installed.

A minimum gap of 5mm is required between sheets. A 10mm foam-backing rod is placed in the gap, which is then sealed with a polyurethane sealant.

This gap needs to be taken into account when setting out the framing. For example for 1200mm wide sheets at a nominal 600mm framing centres the actual framing centres will be:

$1205 / 2 = 602.5\text{mm}$. (round to 603mm and leave 6mm gap between sheets).

FRAMING

Timber or hot dipped galvanised steel joists are suitable framing member for Compressed Flooring.

For exterior application the joist face width must be no less than 45mm min. For interior applications joist and trimmer face width must be no less than 38mm min. Joists must be spaced at 450mm max. for 15mm thick sheets and 600mm max for 18mm and 24mm thick sheets.

FIXING

Lay the sheets with long edges across the joists, with the ends of sheet supported on the centre line of the joist, as shown in Figure 9.

For exterior decking applications leave a 10mm gap between sheets to allow for movement. Insert a 15mm backing rod into the gap and seal with a Polyurethane flexible sealant. (See Figure 8).

Note: Do not bridge sheet joints. With ceramic tiles, ensure tile joints and sheet joints correspond. Refer figure 11.

FIGURE 8 //
EXTERIOR SHEET JOINTS

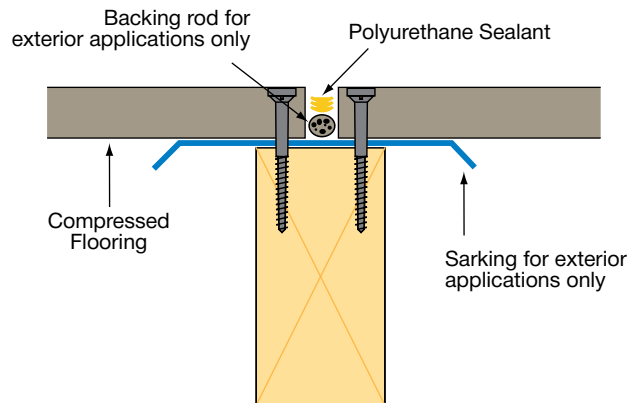
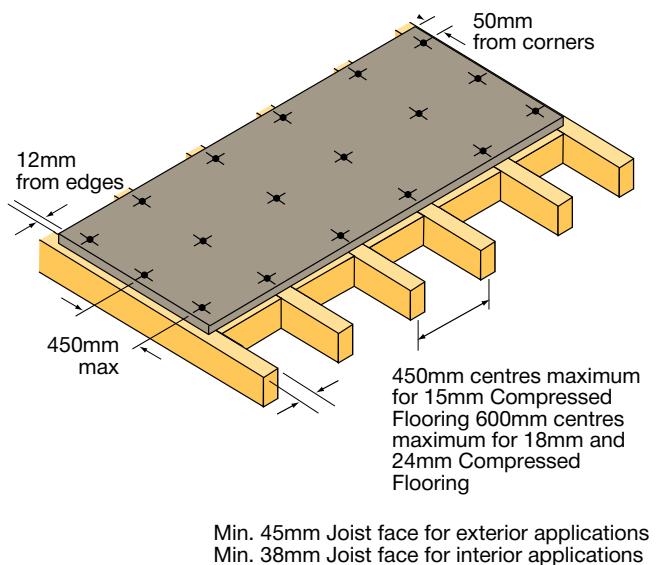

FIGURE 9 //
FIXING PATTERN



TIMBER FRAMING

No 10 Hot Dipped Galvanised Steel or Brass Countersunk Head Wood Screw or equivalent can be used.

SHEET THICKNESS (MM)	RECOMMENDED SCREW LENGTH (MM)	
	INTERIOR APPLICATIONS INCLUDING WET AREAS	EXTERIOR DECKING
15	40	50
18		
24	65	65

LIGHTWEIGHT STEEL FRAMING

No 10 x 30mm Galvanised Countersunk Head Tek Screws or equivalent, which comply with AS 3566-2002.

SHEET PREPARATION

Screw holes should be drilled prior to fixing the sheets to the framework.

Use a sharp Tungsten Carbide tipped masonry drill with a diameter 1mm greater than the screw diameter to allow sheet movement.

Countersink the screw holes to a depth of 3mm using a drill that is 1mm greater in diameter than the screw head or Tungsten Carbide C/S bit.

Screws must not be located closer than 12mm from the sheet edge or closer than 50mm from the sheet corner.

SEALING

After fixing, the screw holes should be sealed using a polyurethane sealant to prevent ingress of water into the framing.

Hint: Before drilling the holes, place a piece of masking tape over each hole location. Leave the tape in place until the hole is drilled, the screw fixed and sealant applied. Removing the tape immediately after sealing will leave the area clear of sealant and scuffmarks.

RAISED DECKS: HABITABLE AREA BELOW

This system utilises a proprietary membrane fixed over the Compressed Flooring to provide waterproofing. A slip-sheet and reinforced mortar bed is installed above the membrane. Finally the tiling or a similar surface finish is installed on top of the mortar bed.

The slip-sheet and mortar bed isolate the tiling from any movement in the framing and Compressed Flooring. Control joint requirements for the tiling are therefore independent of the sheet layout.

The membrane must be installed to the supplier's specifications.

SHEET MEMBRANE

A sheet membrane should be used if the deck width exceeds 3 metres.

A movement control joint is required in the tiling whenever a continuous run exceeds 4.5 metres. Figure 10

SLIP SHEET

The slip-sheet typically consists of two layers, a sheet of 330 g/m² geotextile fabric followed by a sheet of thick plastic sheeting such as Fortecon or equivalent.

FIGURE 10 //
EXTERNAL DECK (TYPICAL) HABITABLE AREA BELOW
 Refer to Ardex Pty Ltd RLA Polymers Pty Ltd or
 Construction Technologies Australia for
 preferred waterproof deck system

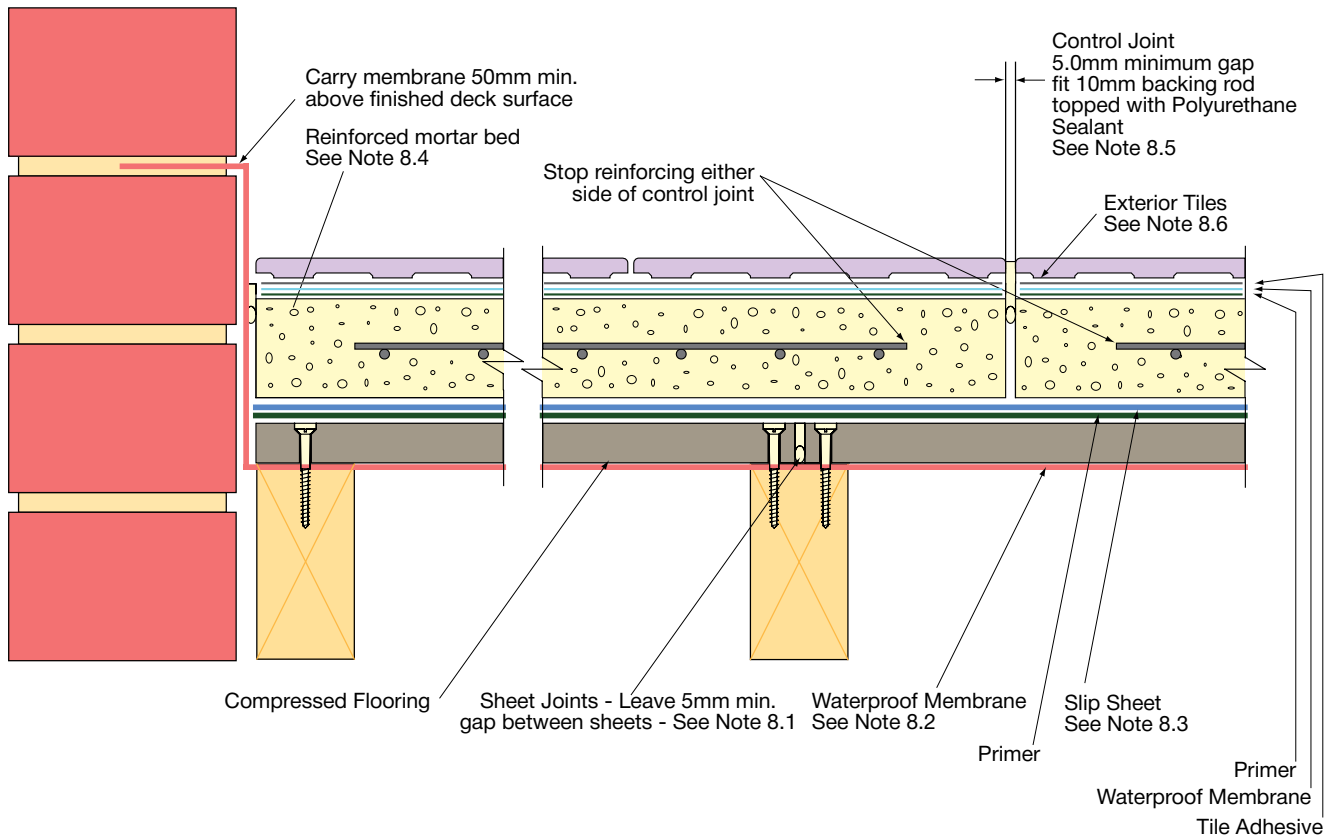

Note 10.1

Compressed Flooring joint details, see Figure 6.

Note 10.2

A waterproof membrane must be applied over the Compressed Flooring and extend up any adjacent walls to 50mm above the finished level of the deck or a sheet membrane such as Bitcoat No.3 or Duraseal. The waterproof membrane must be installed in accordance with the supplier's recommendations. Consult with the tile and tile adhesive manufacturer for their preferred method of achieving a waterproof deck. Typically Ardex or RLA Polymers or Construction Technologies Australia.

Note 10.3

A slip-sheet is placed over the Compressed Flooring to allow the mortar bed and tiling to move independently. Plastic sheetings such as Polyfill Fortecon or builders film is ideal.

Note 10.4

A reinforced mortar bed (minimum thickness 40mm) is placed over the slip-sheet. Typically reinforcing should be 75 x 25 x 2.5mm Galvanised Weld Mesh or equivalent. The mortar bed must be allowed to cure before tiling or applying other finishes.

Note 10.5

Control joints are required in the mortar bed and tiles whenever a continuous run exceeds 4.5m and around the perimeter. These joints need not coincide with joints in the Innova Compressed Flooring.

Note 10.6

Tiles or other applied finishes must be suitable for exterior use. Follow the manufacturer's installation instructions.

SHEET LAYOUT

The visual impact of control joints should be considered when laying out the Innova Compressed Flooring.

Checking the tile size and taking this into account before setting out the framing will reduce the tile cutting and wastage.

LOW LEVEL DECK

This system is suitable for low-level decks including above ground pool surrounds.

Timber framing must be protected from rot by installing flashing over all members. Good under deck ventilation is also necessary.

Steel framing does not require flashing although good ventilation is still recommended.

FIGURE 11 //
EXTERIOR DECKING LOW LEVEL

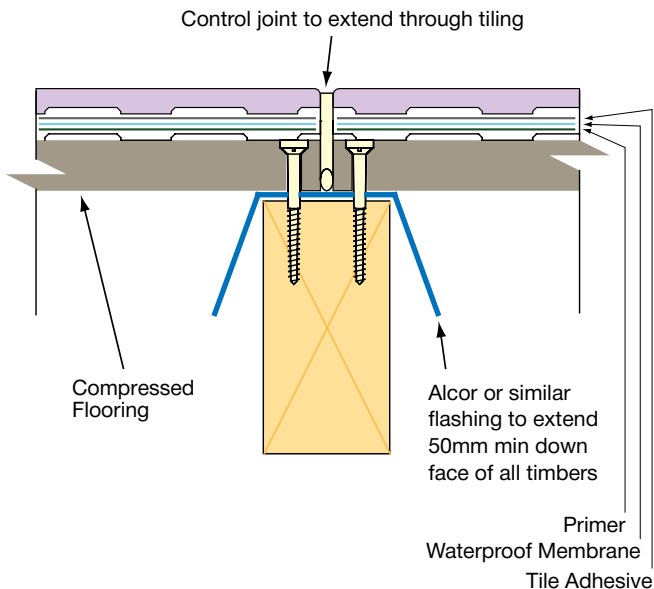

Joint Detail

Note 11.1

All sheet joints as well as control joints must coincide with all joints in the Innova Compressed Flooring. Ensure tiles do not bridge sheet joints as detailed above.

FIGURE 12 //
EDGE DETAIL

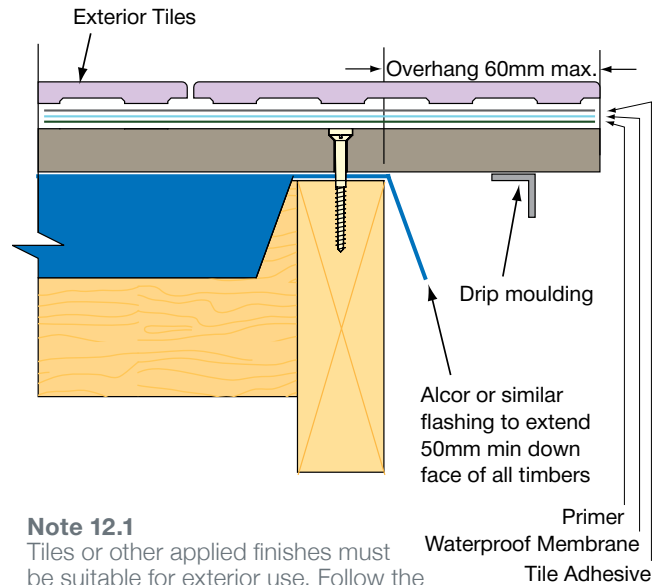

Note 12.1

Tiles or other applied finishes must be suitable for exterior use. Follow the manufacturers installation instructions.

WARRANTY

We warrant that our products are free from defects caused by faulty manufacture or materials for the following period from the date of purchase:

- 25 years for the Nuline™ Plus, Stratum™ and Duraplank™ ranges
- 10 years for the Montage™ range and
- 15 years for all other Innova™ Fibre Cement ranges

If you acquire any defective products, we will repair or replace them, supply equivalent replacement products or refund the purchase price within 30 days of receiving a valid claim, subject to product inspection and confirmation of the existence of a defect by Innova™. We will bear the cost of any such repair, replacement or refund.

This warranty is given by:

Etex Australia Pty Ltd
31 Military Road, Matraville NSW 2036
Phone 1300 724 505

To claim under this warranty, you must provide proof of purchase as a consumer and make a written claim (including any costs of claiming) to us at the address specified above within 30 days after the defect was reasonably apparent, or if the defect was reasonably apparent prior to installation, the claim must be made prior to installation. You may not claim under this warranty for loss or damage caused by:

- faulty or incorrect installation by non-Innova installers (Innova's installation procedures are at www.innovafibrecement.com.au);
- failure to comply with the Building Code of Australia or any applicable legislation, regulations approvals and standards;
- products not made or supplied by Innova;
- abnormal use of the product; or
- normal wear and tear.

The benefits available under this warranty are in addition to other rights and remedies of the consumer under the law. Our goods come with guarantees that cannot be excluded under the Australian Consumer Law. You are entitled to a replacement or refund for a major failure and for compensation for any other reasonably foreseeable loss or damage.

You are also entitled to have the goods repaired or replaced if the goods fail to be of acceptable quality and the failure does not amount to a major failure.

TO CONTACT
YOUR NEAREST
INNOVA STOCKIST,
PLEASE CALL:

ADELAIDE
TELEPHONE
08 8480 1700

BRISBANE
TELEPHONE
07 3548 8400

MELBOURNE
TELEPHONE
03 9492 1700

PERTH
TELEPHONE
08 9311 5500

SYDNEY
TELEPHONE
02 8107 9500

NEW ZEALAND
TELEPHONE
0011 64 9273 1457

TECHNICAL HELP LINE
1300 652 242

INNOVAFIBRECEMENT.
COM.AU

INNOVA FIBRE CEMENT PROVIDES BUILDERS, DEVELOPERS AND ARCHITECTS WITH A RANGE OF DESIGN ALTERNATIVES AND INNOVATIVE PRODUCTS, SUCH AS:

EXTERIOR PRODUCTS AND APPLICATIONS INNOVA RANGE OF PRODUCTS

DURACOM™ / A compressed fibre cement facade system.

DURAFLOOR™ / Is the ultimate flooring product that can be used in both interior and exterior applications.

DURAGRID™ RESIDENTIAL & DURAGRID™ LIGHT COMMERCIAL / A light weight facade giving a modern and durable finish.

DURAGROOVE™ / A vertically grooved exterior facade panel.

DURASCAPE™ / A lightweight exterior facade base sheet with a subtle vertical shadow line.

NULINE™ PLUS / A weatherboard style cladding system.

MONTAGE™ / A pre-finished versatile facade system that can be used internally and externally.

STONESHEET™ / Purpose designed substrate for stone tile facade.

STRATUM™ / Is a trio of plank products, each of which can be used as stand alone products or used together to create a striking exterior cladding solution.

DURASHEET™ / Ideal for the cladding of gables and lining of eaves. Can also be used on commercial soffits and cladding on non impact areas.

DURAPLANK™ / Available in Smooth, Woodgrain and Rusticated finishes, Duraplank™ is ideal for exterior cladding of upper storey conversions or ground level extensions.

DURATEX™ / A base sheet used for textured coatings on exterior wall applications.

COMPRESSED / Used for domestic, commercial sheet for wet areas, flooring, partitions, exterior decking, fascia and facade cladding.

DURALUX™ PLUS / Suitable for exterior applications where it will be sheltered from direct weather.

DURALINER™ PLUS / Suitable for exterior applications where it will be sheltered from direct weather.

INTERIOR PRODUCTS AND APPLICATIONS INNOVA FIBRE CEMENT RANGE OF PRODUCTS

DURALUX™ PLUS / An interior lining board suitable for ceilings and soffits.

DURALINER™ PLUS / An interior lining board, this is the perfect substrate for tiles and is ideal for wet areas.



Safe working practices - Please wear a P1 or P2 mask and safety goggles (approved to AS/NZW1337 standards) whilst cutting or installing Compressed Flooring Substrate. Compressed can be safely handled during unloading or stacking without the use of these precautions.

Cleaning up - Always wet down your work area when cutting Compressed, to ensure that dust is managed. Dispose of any vacuumed dust with care and using containment procedures.