

Models:  
6TRSI-AUD  
6TRSILP-AUD

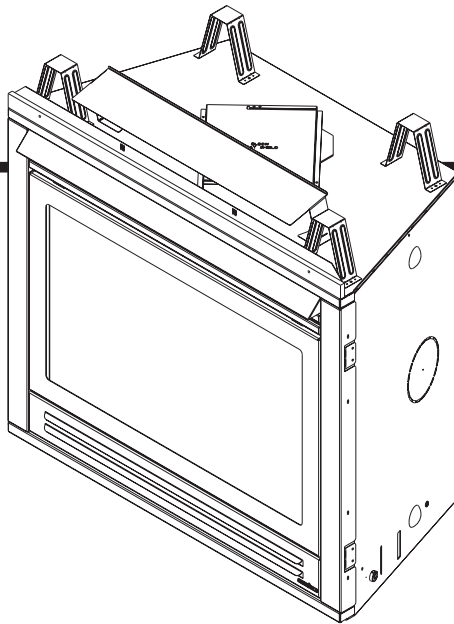

SAI Global  
Gas Safety  
Certified

Ref No GSCS20164  
AS4553:2008

### NOTICE



#### DO NOT DISCARD THIS MANUAL

- Important operating and maintenance instructions included.
- Read, understand and follow these instructions for safe installation and operation.
- Leave this manual with party responsible for use and operation.

**DO NOT  
DISCARD**

**⚠ WARNING:** If the information in these instructions is not followed exactly, a fire or explosion may result causing property damage, personal injury, or death.

- **DO NOT USE OR STORE FLAMMABLE MATERIALS NEAR THIS APPLIANCE.**
- **DO NOT SPRAY AEROSOLS IN THE VICINITY OF THIS APPLIANCE WHILE IT IS IN OPERATION.**
- **What to do if you smell gas**
  - **DO NOT** try to light any appliance.
  - **DO NOT** touch any electrical switch. **DO NOT** use any phone in your building.
  - Immediately call your gas supplier from a neighbor's phone. Follow the gas supplier's instructions.
  - If you cannot reach your gas supplier, call the fire department.
- Installation and service must be performed by a qualified installer, service agency, or the gas supplier.

### ⚠ WARNING



#### HOT SURFACES!

Glass and other surfaces are hot during operation AND cool down.

#### Hot glass will cause burns.

- **DO NOT** touch glass until it is cooled
  - **NEVER** allow children to touch glass
  - Keep children away
  - **CAREFULLY SUPERVISE** children in same room as fireplace.
  - Alert children and adults to hazards of high temperatures.
- High temperatures may ignite clothing or other flammable materials.**
- **DO NOT** PLACE ARTICLES ON OR AGAINST THIS APPLIANCE.
  - Keep clothing, furniture, draperies and other flammable materials away.

***This appliance has been supplied with an integral barrier to prevent direct contact with the fixed glass panel. DO NOT operate the appliance with the barrier removed.***

Contact your dealer or Hearth & Home Technologies if the barrier is not present or help is needed to properly install one.

This is a room sealed appliance and no other ventilation is required than what is provided.



No one builds a better fire

PLEASE READ THIS MANUAL BEFORE INSTALLING  
AND USING THIS APPLIANCE.

**MODELS: 6TRSI-AUD, 6TRSILP-AUD  
ARE SAI GLOBAL APPROVED FOR  
NATURAL GAS, PROPANE OR BUTANE  
AS A BALANCED FLUE HEATER.**

Refer to the appliance data plates for gas consumptions and pressures.

Installation of this appliance should only be carried out by an authorized person in accordance with the manufacturer's instructions. Appliance is to be installed in full compliance with the National Gas Installation Standard AS5601, the manufacturer's instructions, and any local authorities' requirements for gas, electrical and building regulations.

This appliance and its components are tested and safe when installed in accordance with this Installation Manual. Report to your dealer any parts damaged in shipment, specifically check glass condition. The gas logs and flue system components are in separate packages. Read all instructions before starting installation and follow these instructions carefully during

installation to ensure maximum benefit and safety. Failure to follow them will void your warranty and may present a fire hazard.

The Heat & Glo, a brand of Hearth & Home Technologies Inc. warranty will be voided by, and Heat & Glo, a brand of Hearth & Home Technologies Inc. disclaims any responsibility for the following actions:

- Installation of any damaged heater or flue system component
- Modification of the heater or balanced flue system installation other than as instructed by Heat & Glo, a brand of Hearth & Home Technologies Inc.
- Improper positioning of the gas logs or the glass door
- Installation and/or use of any component part not manufactured or approved by Heat & Glo, brand of Hearth & Home Technologies Inc., notwithstanding any independent testing laboratory or other party approval of such component part or accessory.

**It is the responsibility of the professionals involved with the service and installation of the appliance to test the operation of the appliance before leaving the installation site.**

**IMPORTANT:** Read all instructions carefully before starting installation. Failure to follow these installation instructions may result in a possible fire hazard and will void the warranty. Save this manual for future reference.

Heat & Glo, a brand of Hearth & Home Technologies, Inc.  
7571 215<sup>th</sup> Street West, Lakeville, MN 55044  
Copyright 2009 • Printed in U.S.A.

Read this manual before installing or operating this appliance.  
Please retain this owner's manual for future reference.

**A. Congratulations**

Congratulations on selecting a Heat & Glo gas fireplace, an elegant and clean alternative to wood burning fireplaces. The Heat & Glo gas fireplace you have selected is designed to provide the utmost in safety, reliability, and efficiency.

As the owner of a new fireplace, you'll want to read and carefully follow all of the instructions contained in this owner's manual. Pay special attention to all cautions and warnings.

This owner's manual should be retained for future reference. We suggest that you keep it with your other important documents and product manuals.

The information contained in this owner's manual, unless noted otherwise, applies to all models and gas control systems.

Your new Heat & Glo gas fireplace will give you years of durable use and trouble-free enjoyment. Welcome to the Heat & Glo family of fireplace products!

<b>Homeowner Reference Information</b>	<i>We recommend that you record the following pertinent information about your fireplace.</i>
Model Name: _____	Date purchased/installed: _____
Serial Number: _____	Location on fireplace: _____
Dealership purchased from: _____	Dealer Phone: _____
Notes: _____	
_____	

**Listing Label Information/Location**

The model information regarding your specific fireplace can be found on the rating plate usually located in the control area of the fireplace.

**HEAT & GLO** Heat & Glo, a brand of Hearth & Home Technologies Inc.  
No one builds a better fire 7571 215th Street West, Lakeville, MN 55044

SAI Global Certification N°:

Injector Size:.....	DMS (mm)
Gas Inlet Pressure:.....	kPa
Outlet (Manifold) Gas Pressure:.....	kPa
Turndown Outlet Gas Pressure:.....	N/A
Maximum Nominal Gas Consumption.....	MJ/h
Electrical Rating.....	.240V 50hz 1A

This product may be covered by one or more of the following patents: (United States) 4507510, 4686807, 4766876, 4793322, 4811534, 5000162, 5016609, 5076254, 5113843, 5191877, 5218953, 5263471, 5320756, 5320757, 5347983, 5429495, 5452708, 5542407, 5601073, 5613487, 5647340, 5688568, 5762062, 5775408, 5890485, 5931601, 5931602, 5931603, 5947112, 5996575, 6006743, 6019099, 6048195, 6053165, 6145502, 6170481, 6237588, 6296474, 6374822, 6413079, 6439233, 6484712, 6543698, 6550687, 6601579, 6672880, 6688302B2, 6715724B2, 6729551, 6736133, 6748940, 6748942, 6769426, 6774802, 6796302, 6840261, 6848441, 6863064, 6866205, 6869278, 6875012, 6880275, 6908039, 6919884, D320652, D445174, D462436; (Canada) 1297749, 2195264, 2225408, 2313972; (Australia) 780250, 780403, 1418504 or other U.S. and foreign patents pending.

This unit is designed to be recessed into framed construction.  
**TO BE INSTALLED ON WOOD FLOORING OR NON-COMBUSTIBLE FLOORING.**  
*See installation manual for details.*

**Gas Type:** \_\_\_\_\_ **Model:** \_\_\_\_\_

**Serial:** \_\_\_\_\_

**MADE IN USA** 2198-996

Type of Gas →

Model Number →

Serial Number →

## ▲ Safety Alert Key:

- **DANGER!** Indicates a hazardous situation which, if not avoided will result in death or serious injury.
- **WARNING!** Indicates a hazardous situation which, if not avoided could result in death or serious injury.
- **CAUTION!** Indicates a hazardous situation which, if not avoided, could result in minor or moderate injury.
- **NOTICE:** Used to address practices not related to personal injury.

## Table of Contents

A. Congratulations . . . . .	3
B. Limited Lifetime Warranty . . . . .	6

### 1 Listing and Code Approvals

A. Appliance Certification . . . . .	8
B. Gas Pressure Requirements . . . . .	8
C. High Altitude Installations . . . . .	8
D. Non-Combustible Materials Specification . . . . .	8
E. Combustible Materials Specification . . . . .	8
F. Electrical Codes . . . . .	8

## User Guide

### 2 Operating Instructions

A. Gas Fireplace Safety . . . . .	9
B. Your Fireplace . . . . .	9
C. Fan Kit . . . . .	10
D. Clear Space . . . . .	10
E. Decorative Doors and Fronts . . . . .	10
F. Fixed Glass Assembly . . . . .	10
G. Remote Controls, Wall Controls and Wall Switches . . . . .	10
H. Before Lighting Fireplace . . . . .	10
I. Lighting Instructions (IPI) . . . . .	11
J. Control Module Operation . . . . .	12
K. After Fireplace is Lit . . . . .	13
L. Frequently Asked Questions . . . . .	13

### 3 Maintenance and Service

A. Maintenance Tasks-Homeowner . . . . .	14
B. Maintenance Tasks-Qualified Service Technician . . . . .	15

## Installer Guide

### 4 Getting Started

A. Typical Appliance System . . . . .	16
B. Design and Installation Considerations . . . . .	17
C. Tools and Supplies Needed . . . . .	17
D. Inspect Appliance and Components . . . . .	17

### 5 Framing and Clearances

A. Selecting Appliance Location . . . . .	18
B. Constructing the Appliance Chase . . . . .	19
C. Clearances . . . . .	19
D. Mantel and Wall Projections . . . . .	20

### 6 Termination Locations

A. Vent Termination Minimum Clearances . . . . .	21
--	----

### 7 Vent Information and Diagrams

A. Approved Pipe . . . . .	23
B. Vent Table Key . . . . .	23
C. Use of Elbows . . . . .	23
D. Measuring Standards . . . . .	23
E. Vent Diagrams . . . . .	23

### 8 Vent Clearances and Framing

A. Pipe Clearances to Combustibles . . . . .	35
B. Wall Penetration Framing . . . . .	35
C. Install the Ceiling Firestop . . . . .	36
D. Install Attic Insulation Shield . . . . .	37
E. Installing the Optional Heat-Zone-240V Kit . . . . .	37

### 9 Appliance Preparation

A. Top Vent . . . . .	38
B. Rear Vent . . . . .	39
C. Installing the Non-combustible Board . . . . .	40
D. Securing and Leveling the Appliance . . . . .	40
E. Covers Removal For Servicing . . . . .	41
F. Components Removal For Service . . . . .	41
G. Parts Replacement . . . . .	41
H. Adjustments And Replacement Parts . . . . .	41
I. Install Trim and/or Surround . . . . .	41
J. Air Shutter Setting . . . . .	41

### 10 Installing Vent Pipe

A. Assemble Vent Sections . . . . .	42
B. Assemble Slip Sections . . . . .	43
C. Secure the Vent Sections . . . . .	43
D. Disassemble Vent Sections . . . . .	44
E. Install Support Brackets . . . . .	44
F. Install Firestops . . . . .	45
G. Flue Termination . . . . .	46
H. Heat Shield Requirements for Horizontal Termination . . . . .	47
I. Install Metal Roof Flashing . . . . .	47
J. Assemble and Install Storm Collar . . . . .	48
K. Install Vertical Termination Cap . . . . .	48

### 11 Gas Information

A. Gas Pressure Requirements . . . . .	49
B. Gas Connection . . . . .	49

### 12 Electrical Information

A. Wiring Requirements . . . . .	51
B. IntelliFire Ignition System Wiring . . . . .	51
C. Optional Accessories Requirements . . . . .	51
D. Blower . . . . .	52
E. Control Module Operation . . . . .	53



### **13 Finishing**

- A. Mantel and Wall Projections . . . . . 61
- B. Facing Material . . . . . 61

### **14 Appliance Setup**

- A. Remove Fixed Glass Assembly . . . . . 62
- B. Remove the Shipping Materials . . . . . 62
- C. Clean the Appliance . . . . . 62
- D. Accessories . . . . . 62
- E. Log Placement Instructions . . . . . 63

### **15 Troubleshooting**

- A. IntelliFire Plus™ Ignition System . . . . . 65

### **16 Reference Materials**

- A. Appliance Dimension Diagram . . . . . 67
- B. Maintenance Tasks . . . . . 68
- C. Vent Components Diagrams . . . . . 69
- D. Service Parts . . . . . 72
- E. Contact Information . . . . . 75

➔ = Contains updated information.

## B. Limited Lifetime Warranty

### Hearth & Home Technologies Inc. LIMITED LIFETIME WARRANTY

Hearth & Home Technologies Inc., on behalf of its hearth brands ("HHT"), extends the following warranty for HHT gas, wood, pellet, coal and electric hearth appliances that are purchased from an HHT authorized dealer.

#### **WARRANTY COVERAGE:**

HHT warrants to the original owner of the HHT appliance at the site of installation, and to any transferee taking ownership of the appliance at the site of installation within two years following the date of original purchase, that the HHT appliance will be free from defects in materials and workmanship at the time of manufacture. After installation, if covered components manufactured by HHT are found to be defective in materials or workmanship during the applicable warranty period, HHT will, at its option, repair or replace the covered components. HHT, at its own discretion, may fully discharge all of its obligations under such warranties by replacing the product itself or refunding the verified purchase price of the product itself. The maximum amount recoverable under this warranty is limited to the purchase price of the product. This warranty is subject to conditions, exclusions and limitations as described below.

#### **WARRANTY PERIOD:**

Warranty coverage begins on the date of installation. In the case of new home construction, warranty coverage begins on the date of first occupancy of the dwelling or six months after the sale of the product by an independent, authorized HHT dealer/ distributor, whichever occurs earlier. The warranty shall commence no later than 24 months following the date of product shipment from HHT, regardless of the installation or occupancy date. The warranty period for parts and labor for covered components is produced in the following table.

The term "Limited Lifetime" in the table below is defined as: 20 years from the beginning date of warranty coverage for gas appliances, and 10 years from the beginning date of warranty coverage for wood, pellet, and coal appliances. These time periods reflect the minimum expected useful lives of the designated components under normal operating conditions.

Warranty Period		HHT Manufactured Appliances and Venting							Components Covered
Parts	Labor	Gas	Wood	Pellet	EPA Wood	Coal	Electric	Venting	
1 Year		X	X	X	X	X	X	X	All parts and material except as covered by Conditions, Exclusions, and Limitations listed
2 years				X	X	X			Igniters, electronic components, and glass
		X	X	X	X	X			Factory-installed blowers
			X						Molded refractory panels
3 years				X					Firepots and burnpots
5 years	1 year			X	X				Castings and baffles
7 years	3 years		X	X	X				Manifold tubes, HHT chimney and termination
10 years	1 year	X							Burners, logs and refractory
Limited Lifetime	3 years	X	X	X	X	X			Firebox and heat exchanger
90 Days		X	X	X	X	X	X	X	All replacement parts beyond warranty period

See conditions, exclusions, and limitations on next page.

## **WARRANTY CONDITIONS:**

- This warranty only covers HHT appliances that are purchased through an HHT authorized dealer or distributor. A list of HHT authorized dealers is available on the HHT branded websites.
- This warranty is only valid while the HHT appliance remains at the site of original installation.
- Contact your installing dealer for warranty service. If the installing dealer is unable to provide necessary parts, contact the nearest HHT authorized dealer or supplier. Additional service fees may apply if you are seeking warranty service from a dealer other than the dealer from whom you originally purchased the product.
- Check with your dealer in advance for any costs to you when arranging a warranty call. Travel and shipping charges for parts are not covered by this warranty.

## **WARRANTY EXCLUSIONS:**

This warranty does not cover the following:

- Changes in surface finishes as a result of normal use. As a heating appliance, some changes in color of interior and exterior surface finishes may occur. This is not a flaw and is not covered under warranty.
- Damage to printed, plated, or enameled surfaces caused by fingerprints, accidents, misuse, scratches, melted items, or other external sources and residues left on the plated surfaces from the use of abrasive cleaners or polishes.
- Repair or replacement of parts that are subject to normal wear and tear during the warranty period. These parts include: paint, wood, pellet and coal gaskets; firebricks; grates; flame guides; and the discoloration of glass.
- Minor expansion, contraction, or movement of certain parts causing noise. These conditions are normal and complaints related to this noise are not covered by this warranty.
- Damages resulting from: (1) failure to install, operate, or maintain the appliance in accordance with the installation instructions, operating instructions, and listing agent identification label furnished with the appliance; (2) failure to install the appliance in accordance with local building codes; (3) shipping or improper handling; (4) improper operation, abuse, misuse, continued operation with damaged, corroded or failed components, accident, or improperly/incorrectly performed repairs; (5) environmental conditions, inadequate ventilation, negative pressure, or drafting caused by tightly sealed constructions, insufficient make-up air supply, or handling devices such as exhaust fans or forced air furnaces or other such causes; (6) use of fuels other than those specified in the operating instructions; (7) installation or use of components not supplied with the appliance or any other components not expressly authorized and approved by HHT; (8) modification of the appliance not expressly authorized and approved by HHT in writing; and/or (9) interruptions or fluctuations of electrical power supply to the appliance.
- Non-HHT venting components, hearth components or other accessories used in conjunction with the appliance.
- Any part of a pre-existing fireplace system in which an insert or a decorative gas appliance is installed.
- HHT's obligation under this warranty does not extend to the appliance's capability to heat the desired space. Information is provided to assist the consumer and the dealer in selecting the proper appliance for the application. Consideration must be given to appliance location and configuration, environmental conditions, insulation and air tightness of the structure.

### **This warranty is void if:**

- The appliance has been over-fired or operated in atmospheres contaminated by chlorine, fluorine, or other damaging chemicals. Over-firing can be identified by, but not limited to, warped plates or tubes, rust colored cast iron, bubbling, cracking and discoloration of steel or enamel finishes.
- The appliance is subjected to prolonged periods of dampness or condensation.
- There is any damage to the appliance or other components due to water or weather damage which is the result of, but not limited to, improper chimney or venting installation.

## **LIMITATIONS OF LIABILITY:**

- The owner's exclusive remedy and HHT's sole obligation under this warranty, under any other warranty, express or implied, or in contract, tort or otherwise, shall be limited to replacement, repair, or refund, as specified above. In no event will HHT be liable for any incidental or consequential damages caused by defects in the appliance. Some states do not allow exclusions or limitation of incidental or consequential damages, so these limitations may not apply to you. This warranty gives you specific rights; you may also have other rights, which vary from state to state. EXCEPT TO THE EXTENT PROVIDED BY LAW, HHT MAKES NO EXPRESS WARRANTIES OTHER THAN THE WARRANTY SPECIFIED HEREIN. THE DURATION OF ANY IMPLIED WARRANTY IS LIMITED TO DURATION OF THE EXPRESSED WARRANTY SPECIFIED ABOVE.

# 1 Listing and Code Approvals

## A. Appliance Certification

**MODELS:** 6TRSI-AUD, 6TRSILP-AUD

**LABORATORY:** SAI Global

**TYPE:** Gas Space Heating Appliance

**STANDARD:** AS4553-2008

The Heat & Glo gas appliances discussed in this Installer's Guide have been tested to certification standards and listed by the applicable laboratories.

This appliance must be installed in accordance with the rules in force.  
NOX Class 5 for G20, NOX Class 5 for G31

## B. Gas Pressure Requirements

**WARNING! Risk of Explosion!** An in-line regulator *MUST* be installed if the gas pressure exceeds 3.7 kPa. Failure to install a regulator could damage valve.

Pressure requirements for 6TRSI-AUD and 6TRSILP-AUD fireplaces are shown in table below.

Two taps are provided on the right hand side of the gas control for a test gauge connection to measure the inlet and outlet pressures.

The fireplace and its individual shut-off valve must be disconnected from the gas supply piping system during any pressure testing of the system at test pressures in excess of 60 mbar or 6 kPa.

If the fireplace must be isolated from the gas supply piping system by closing an individual shut-off valve, it must be of the handle-less type.

	Natural Gas	Propane
Inlet Pressure	1.13 kPa	2.75 kPa
Outlet Gas Pressure	0.80 kPa	2.40 kPa
Maximum Gas Consumption	36 MJ/h	34.0 MJ/h
Burner Injector	DMS 33 (2.87 mm)	DMS 51 (1.70 mm)
Pilot Injector	.0121	0.0181

An in-line regulator *MUST* be installed if the gas pressure exceeds 3.7 kPa. Failure to install a regulator could damage valve.

## C. High Altitude Installations

**NOTICE:** If the heating value of the gas has been reduced, these rules do not apply. Check with your local gas utility or authorities having jurisdiction.

When installing above 610 meter elevation:

Reduce input rate 4% for each 305 meters feet above 610 meters.

## D. Non-Combustible Materials Specification

Material which will not ignite and burn. Such materials are those consisting entirely of steel, iron, brick, tile, concrete, slate, glass or plasters, or any combination thereof.

Materials that are reported as passing **ASTM E 136, Standard Test Method for Behavior of Materials in a Vertical Tube Furnace at 750 °C** and **UL763** shall be considered non-combustible materials.

## E. Combustible Materials Specification

Materials made of or surfaced with wood, compressed paper, plant fibers, plastics, or other material that can ignite and burn, whether flame proofed or not, or plastered or unplastered shall be considered combustible materials.

## F. Electrical Codes

All electrical safety testing has been done following the EN 60335-2-102 standard. Local codes apply.

## A. Gas Fireplace Safety

### ⚠ WARNING



#### HOT SURFACES!

Glass and other surfaces are hot during operation AND cool down.

#### Hot glass will cause burns.

- DO NOT touch glass until it is cooled
- NEVER allow children to touch glass
- Keep children away

- CAREFULLY SUPERVISE children in same room as fireplace.
- Alert children and adults to hazards of high temperatures.

#### High temperatures may ignite clothing or other flammable materials.

- Keep clothing, furniture, draperies and other flammable materials away.

***This appliance has been supplied with an integral barrier to prevent direct contact with the fixed glass panel. DO NOT operate the appliance with the barrier removed.***

Contact your dealer or Hearth & Home Technologies if the barrier is not present or help is needed to properly install one.

If you expect that small children or vulnerable adults may come into contact with this fireplace, the following precautions are recommended:

- Install a physical barrier such as:
  - A decorative firescreen.
  - Adjustable safety gate.
- Install a switch lock or a wall/remote control with child protection lockout feature.

- Keep remote controls out of reach of children.
- Never leave children alone near a hot fireplace, whether operating or cooling down.
- Teach children to NEVER touch the fireplace.
- Consider not using the fireplace when children will be present.

Contact your dealer for more information, or visit: [www.hpba.org/staysafe](http://www.hpba.org/staysafe).

To prevent unintended operation when not using your fireplace for an extended period of time (summer months, vacations, trips, etc):

- Remove batteries from remote controls.
- Turn off wall controls.
- Unplug 6 volt transformer plug and remove batteries on IPI models.

## B. Your Fireplace

**WARNING! DO NOT operate fireplace before reading and understanding operating instructions. Failure to operate fireplace according to operating instructions could cause fire or injury.**

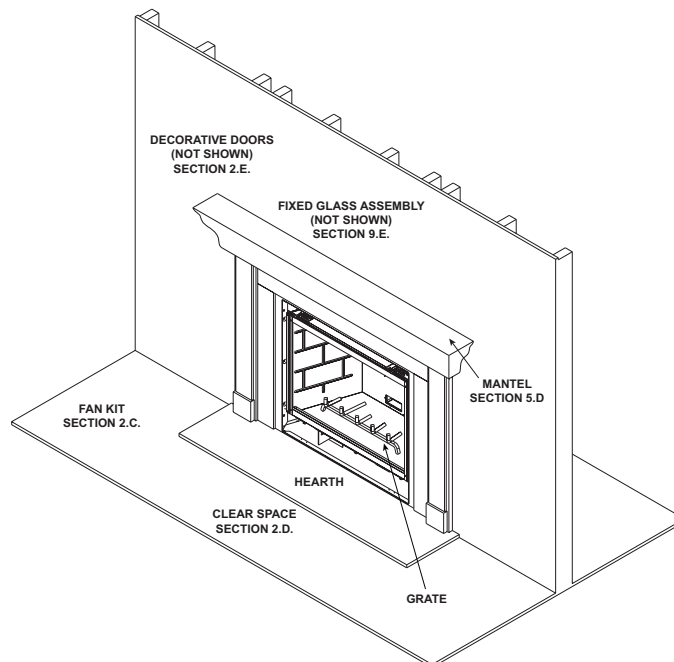

Figure 2.1 General Operating Parts

### C. Fan Kit

A fan is shipped with this appliance.

### D. Clear Space

**WARNING! DO NOT** place combustible objects in front of the fireplace or block louvers. High temperatures may start a fire. See Figure 2.2.

Avoid placing candles and other heat-sensitive objects on mantel or hearth. Heat may damage these objects.

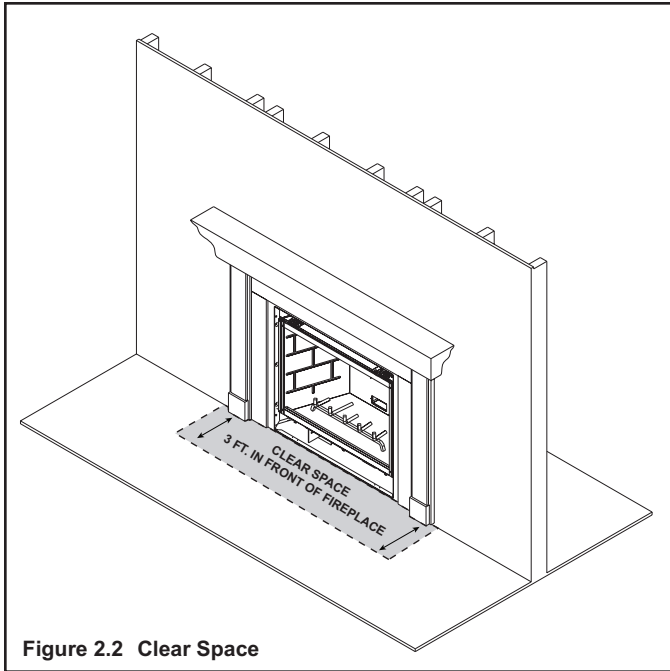

### E. Decorative Doors and Fronts

**WARNING! Risk of Fire!** Install **ONLY** doors or fronts approved by Hearth & Home Technologies. Unapproved doors or fronts may cause fireplace to overheat.

**This fireplace has been supplied with an integral barrier to prevent direct contact with the fixed glass panel. DO NOT operate the fireplace with the barrier removed.**

Contact your dealer or Hearth & Home Technologies if the barrier is not present or help is needed to properly install one.

For more information refer to the instructions supplied with your decorative door or front.

### F. Fixed Glass Assembly

See Section 9.E.

### G. Remote Controls, Wall Controls and Wall Switches

Follow the instructions supplied with the control installed to operate your fireplace:

For safety:

- Install a switch lock or a wall/remote control with child protection lockout feature.
- Keep remote controls out of reach of children.

See your dealer if you have questions.

### H. Before Lighting Fireplace

Before operating this fireplace for the first time, **have a qualified service technician:**

- Verify all shipping materials have been removed from inside and/or underneath the firebox.
- Review proper placement of logs, ember material and/or other decorative materials.
- Check the wiring.
- Check the air shutter adjustment.
- Ensure that there are no gas leaks.
- Ensure that the glass is sealed and in the proper position and that the integral barrier is in place.

**WARNING! Risk of Fire or Asphyxiation! DO NOT operate fireplace with fixed glass assembly removed.**



# I. Lighting Instructions (IPI)

## FOR YOUR SAFETY READ BEFORE LIGHTING

**WARNING:** If you do not follow these instructions exactly, a fire or explosion may result causing property damage, personal injury or loss of life.

- A.** This appliance is equipped with an intermittent pilot ignition (IPI) device which automatically lights the burner. **DO NOT** try to light the burner by hand.
- B. BEFORE LIGHTING,** smell all around the appliance area for gas. Be sure to smell next to the floor because some gas is heavier than air and will settle on the floor.
- WHAT TO DO IF YOU SMELL GAS**
  - **DO NOT** try to light any appliance.
  - **DO NOT** touch any electric switch; do not use any phone in your building.
- Immediately call your gas supplier from a neighbor's phone. Follow the gas supplier's instructions.
- If you cannot reach your gas supplier, call the fire department.
- C. DO NOT** use this appliance if any part has been under water. Immediately call a qualified service technician to inspect the appliance and to replace any part of the control system and any gas control which has been under water.

### WARNING:

**DO NOT CONNECT LINE VOLTAGE (110/120 VAC OR 220/240 VAC) TO THE CONTROL VALVE.**

Improper installation, adjustment, alteration, service or maintenance can cause injury or property damage. Refer to the owner's information manual provided with this appliance.

This appliance needs fresh air for safe operation and must be installed so there are provisions for adequate combustion and ventilation air.

If not installed, operated, and maintained in accordance with the manufacturer's instructions, this product could expose you to substances in fuel or fuel combustion which are known to the State of California to cause cancer, birth defects, or other reproductive harm.

Keep burner and control compartment clean. See installation and operating instructions accompanying appliance.

For additional information on operating your Hearth & Home Technologies fireplace, please refer to [www.fireplaces.com](http://www.fireplaces.com).

### CAUTION:

Hot while in operation. **DO NOT** touch. Keep children, clothing, furniture, gasoline and other liquids having flammable vapors away.

**DO NOT** operate the appliance with fixed glass assembly removed, cracked or broken. Replacement of the fixed glass assembly should be done by a licensed or qualified service person.

### NOT FOR USE WITH SOLID FUEL

For use with natural gas and propane. A conversion kit, as supplied by the manufacturer, shall be used to convert this appliance to the alternate fuel.

**Also Certified for Installation in a Bedroom or a Bedsitting Room.**

For assistance or additional information, consult a qualified installer, service agency or the gas supplier.

## LIGHTING INSTRUCTIONS (IPI)

1. This appliance is equipped with an ignition device which automatically lights the burner. **DO NOT** try to light the burner by hand.

**GAS VALVE**

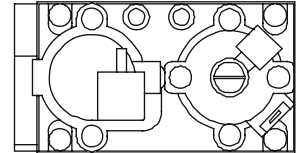

2. Wait five (5) minutes to clear out any gas. Then smell for gas, including near the floor. If you smell gas, STOP! Follow "B" in the Safety Information located on the left side of this label. If you do not smell gas, go to next step.
3. To light the burner:
  - Equipped with wall switch: Turn ON/OFF switch to ON.
  - Equipped with remote or wall control: Press ON or FLAME button.
  - Equipped with thermostat: Set temperature to desired setting.
4. If the appliance does not light after three tries, call your service technician or gas supplier.

## TO TURN OFF GAS TO APPLIANCE

1. Equipped with wall switch: Turn ON/OFF switch to OFF.
  - Equipped with remote or wall control: Press OFF button.
  - Equipped with thermostat: Set temperature to lowest setting.
2. Service technician should turn off electric power to the control when performing service.

593-913G

Final inspection by \_\_\_\_\_

## J. Control Module Operation

1. The control module has an ON/OFF/REMOTE selector switch that must be set. See Figure 2.3.

**OFF Position:** Appliance will ignore all power inputs and will not respond to any commands from a wall switch or remote. The unit should be in the OFF position during installation, service, battery installation, fuel conversion, and in the event that the control goes into LOCK-OUT mode as a result of an error code.

**ON Position:** Appliance will ignite and run continuously in the HI flame setting, with no adjustment in flame output. This mode of operation is primarily used for initial installation or power outage operation with battery backup.

**REMOTE Position:** Appliance will initiate commands from an optional wired wall switch and/or the wireless remote (RC300AU).

2. If using a wired wall switch with the module in REMOTE mode, the flame output can be adjusted with the HI/LO selector switch on the module. See Figure 2.3. Note that the flame HI/LO selector switch will become inactive once an optional remote control (RC300AU) is programmed to the control module. Note that the control module will always ignite the fireplace on HI and remain so for the initial 10 seconds of operation. If the HI/LO is switched to the LO position, the flame output will automatically drop to the lowest setting after the flame has been established for 10 sec. After this 10 second period, the flame can be adjusted from HI to LO with the switch.
3. The control module has safety feature that automatically shuts down the fireplace after 9 hours of continuous operation without receiving a command from the RC300AU remote.
4. If you intend to use both an optional wired wall switch and the RC300AU remote control to operate your fireplace, the wall switch will override any commands given by the remote.
5. The module has the capability to recognize potential malfunctions. If these occur, it will fail to ignite and/or respond to a command to ignite via the wall switch and/or remote. In this case, the module may have gone into LOCK-OUT mode. In this state, it will emit a RED/GREEN LED error code. To reset the error code, switch the selector to OFF, and then back to REMOTE or ON. If the ignition command again fails, the module will emit an LED error code, prior to going back into LOCK-OUT mode. Contact your dealer for service if this occurs.

**Note:** If the module is in LOCK-OUT mode, resetting the circuit breaker to the appliance will also reset the module.

**Note:** For units installed in Australia, the residence's 220/240 wall outlet to which this appliance's power cord is connected, must be wired to an in-line on/off switch. This is required for servicing and/or resetting the control module in the event of a control module LOCK-OUT.

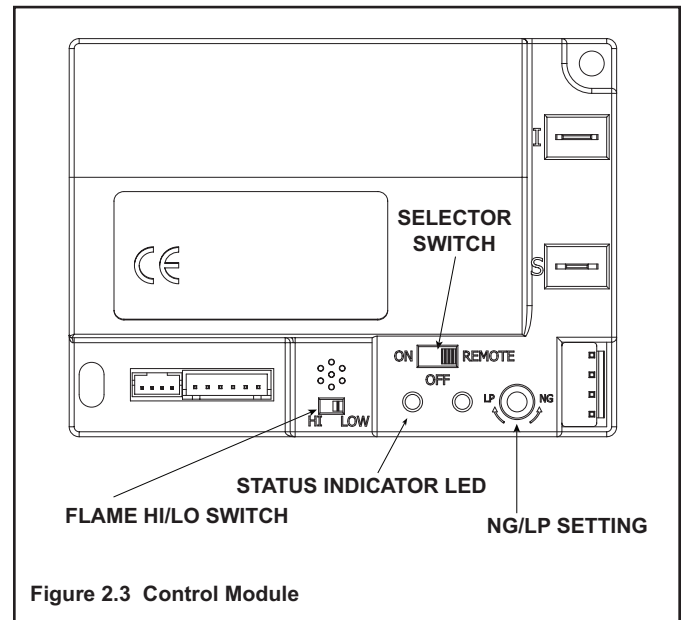

## K. After Fireplace is Lit

### Initial Break-in Procedure

- The fireplace should be run three to four hours continuously on high.
- Turn the fireplace off and allow it to completely cool.
- Remove fixed glass assembly. See Section 9.E.
- Clean fixed glass assembly. See Section 3.
- Replace the fixed glass assembly and run continuously on high an additional 12 hours.

This cures the materials used to manufacture the fireplace.

### **NOTICE! Open windows for air circulation during fireplace break-in.**

- *Some people may be sensitive to smoke and odors.*
- *Smoke detectors may activate.*

## L. Frequently Asked Questions

ISSUE	SOLUTIONS
Condensation on the glass	This is a result of gas combustion and temperature variations. As the appliance warms, this condensation will disappear.
Blue flames	This is a result of normal operation and the flames will begin to yellow as the appliance is allowed to burn for 20 to 40 minutes.
Odor from appliance	When first operated, this appliance may release an odor for the first several hours. This is caused by the curing of the paint and the burning off of any oils remaining from manufacturing. Odor may also be released from finishing materials and adhesives used around the appliance.
Film on the glass	This is a normal result of the curing process of the paint and logs. Glass should be cleaned within 3 to 4 hours of initial burning to remove deposits left by oils from the manufacturing process. A non-abrasive cleaner such as gas fireplace glass cleaner may be necessary. See your dealer.
Metallic noise	Noise is caused by metal expanding and contracting as it heats up and cools down, similar to the sound produced by a furnace or heating duct. This noise does not affect the operation or longevity of the appliance.
Is it normal to see the pilot flame burn continually?	In an intermittent pilot ignition system (IPI), the pilot flame should turn off when appliance is turned off. Some optional control systems available with IPI models may allow pilot flame to remain lit.

# 3 Maintenance and Service

Any safety screen or guard removed for servicing must be replaced prior to operating the fireplace.

When properly maintained, your fireplace will give you many years of trouble-free service. We recommend annual service by a qualified service technician.

## A. Maintenance Tasks-Homeowner

Installation and repair should be done by a qualified service technician only. The fireplace should be inspected before use and at least annually by a professional service person.

The following tasks may be performed annually by the homeowner. If you are uncomfortable performing any of the listed tasks, please call your dealer for a service appointment.

More frequent cleaning may be required due to lint from carpeting or other factors. Control compartment, burner and circulating air passageway of the fireplace must be kept clean.

**CAUTION! Risk of Burns!** *The fireplace should be turned off and cooled before servicing.*

### Glass Cleaning

**Frequency:** Seasonally

**By:** Homeowner

**Tools Needed:** Protective gloves, glass cleaner, drop cloth and a stable work surface.

**CAUTION! Handle fixed glass assembly with care.** *Glass is breakable.*

- *Avoid striking, scratching or slamming glass*
- *Avoid abrasive cleaners*
- **DO NOT** clean glass while it is hot
- Prepare a work area large enough to accommodate fixed glass assembly and door frame by placing a drop cloth on a flat, stable surface.

**Note:** Fixed glass assembly and gasketing may have residue that can stain carpeting or floor surfaces.

- Remove door or decorative front from fireplace and set aside on work surface.
- See Section 9.E for instructions to remove fixed glass assembly.
- Clean glass with a non-abrasive commercially available cleaner.
  - Light deposits: Use a soft cloth with soap and water
  - Heavy deposits: Use commercial fireplace glass cleaner (consult with your dealer)
- Carefully set fixed glass assembly in place on fireplace. Hold glass in place with one hand and secure glass latches with the other hand.
- Reinstall door or decorative front.

### Doors, Surrounds, Fronts

**Frequency:** Annually

**By:** Homeowner

**Tools needed:** Protective gloves, stable work surface

- Assess condition of screen and replace as necessary.
- Inspect for scratches, dents or other damage and repair as necessary.
- Check that louvers are not blocked.
- Vacuum and dust surfaces.

### Remote Control

**Frequency:** Seasonally

**By:** Homeowner

**Tools needed:** Replacement batteries and remote control instructions.

- Locate remote control transmitter and receiver.
- Verify operation of remote. Refer to remote control operation instructions for proper calibration and setup procedure.
- Place batteries as needed in remote transmitters and battery-powered receivers.
- Place remote control out of reach of children.

If not using your fireplace for an extended period of time (summer months, vacations/trips, etc), to prevent unintended operation:

- Remove batteries from remote controls.
- Unplug 6 volt transformer plug on IPI models.
- Remove battery backup from control module.

### Venting

**Frequency:** Seasonally

**By:** Homeowner

**Tools needed:** Protective gloves and safety glasses.

- Inspect venting and termination cap for blockage or obstruction such plants, bird nests, leaves, snow, debris, etc.
- Verify termination cap clearance to subsequent construction (building additions, decks, fences, or sheds). See Section 6.
- Inspect for corrosion or separation.
- Verify weather stripping, sealing and flashing remains intact.
- Inspect draft shield to verify it is not damaged or missing.

## B. Maintenance Tasks-Qualified Service Technician

The following tasks must be performed by a qualified service technician.

### Gasket Seal and Glass Assembly Inspection

**Frequency:** Annually

**By:** Qualified Service Technician

**Tools needed:** Protective gloves, drop cloth and a stable work surface.

- Inspect gasket seal and its condition.
- Inspect fixed glass assembly for scratches and nicks that can lead to breakage when exposed to heat.
- Confirm there is no damage to glass or glass frame. Replace as necessary.
- Verify that fixed glass assembly is properly retained and attachment components are intact and not damaged. Replace as necessary.

### Logs

**Frequency:** Annually

**By:** Qualified Service Technician

**Tools needed:** Protective gloves.

- Inspect for damaged or missing logs. Replace as necessary. Refer to Section 14 for log placement instructions.
- Verify correct log placement and no flame impingement causing sooting. Correct as necessary.

### Firebox

**Frequency:** Annually

**By:** Qualified Service Technician

**Tools needed:** Protective gloves, sandpaper, steel wool, cloths, mineral spirits, primer and touch-up paint.

- Inspect for paint condition, warped surfaces, corrosion or perforation. Sand and repaint as necessary.
- Replace fireplace if firebox has been perforated.

### Control Compartment and Firebox Top

**Frequency:** Annually

**By:** Qualified Service Technician

**Tools needed:** Protective gloves, vacuum cleaner, dust cloths

- Vacuum and wipe out dust, cobwebs, debris or pet hair. Use caution when cleaning these areas. Screw tips that have penetrated the sheet metal are sharp and should be avoided.
- Remove all foreign objects.
- Verify unobstructed air circulation.

## Burner Ignition and Operation

**Frequency:** Annually

**By:** Qualified Service Technician

**Tools needed:** Protective gloves, vacuum cleaner, whisk broom, flashlight, voltmeter, indexed drill bit set, and a manometer.

- Verify burner is properly secured and aligned with pilot or igniter.
- Clean off burner top, inspect for plugged ports, corrosion or deterioration. Replace burner if necessary.
- Replace Glowing embers with new dime-size pieces. **DO NOT** block ports or obstruct lighting paths.
- Verify batteries have been removed from battery back-up IPI systems to prevent premature battery failure or leaking.
- Check for smooth lighting and ignition carryover to all ports. Verify that there is no ignition delay.
- Inspect for lifting or other flame problems.
- Verify air shutter setting is correct. See Section 9.J for required air shutter setting. Verify air shutter is clear of dust and debris.
- Inspect orifice for soot, dirt and corrosion. Verify orifice size is correct. See Service Parts List for proper orifice sizing.
- Verify manifold and inlet pressures. Adjust regulator as required.
- Inspect pilot flame pattern and strength. See Figures 3.1 for proper pilot flame pattern. Clean or replace orifice spud as necessary.
- Inspect IPI flame sensing rod for soot, corrosion and deterioration. Clean with emery cloth or replace as required.
- Verify that there is not a short in flame sense circuit by checking continuity between pilot hood and flame sensing rod. Replace pilot as necessary.

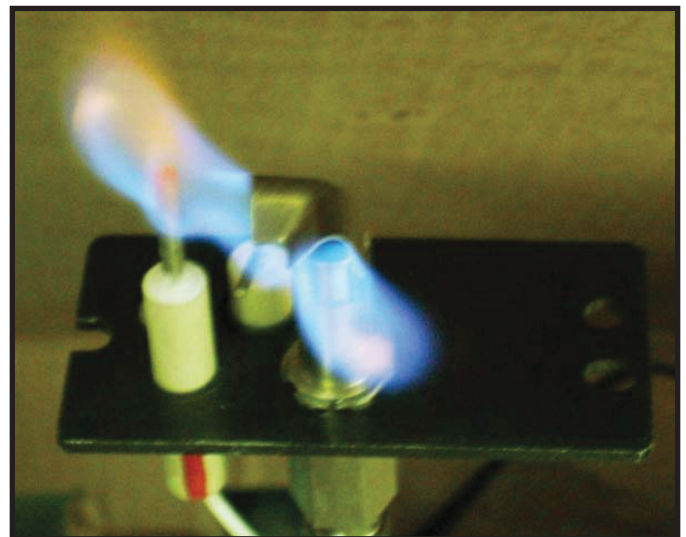

Figure 3.1 IPI Pilot Flame Patterns



# 4 Getting Started

# Installer Guide

## A. Typical Appliance System

**NOTICE:** Illustrations and photos reflect typical installations and are for design purposes only. Illustrations/diagrams are not drawn to scale. Actual product may vary from pictures in manual

**Note:** Dual venting configurations **ARE NOT** allowed. Appliance **MUST** be vented **EITHER** vertically **OR** horizontally.

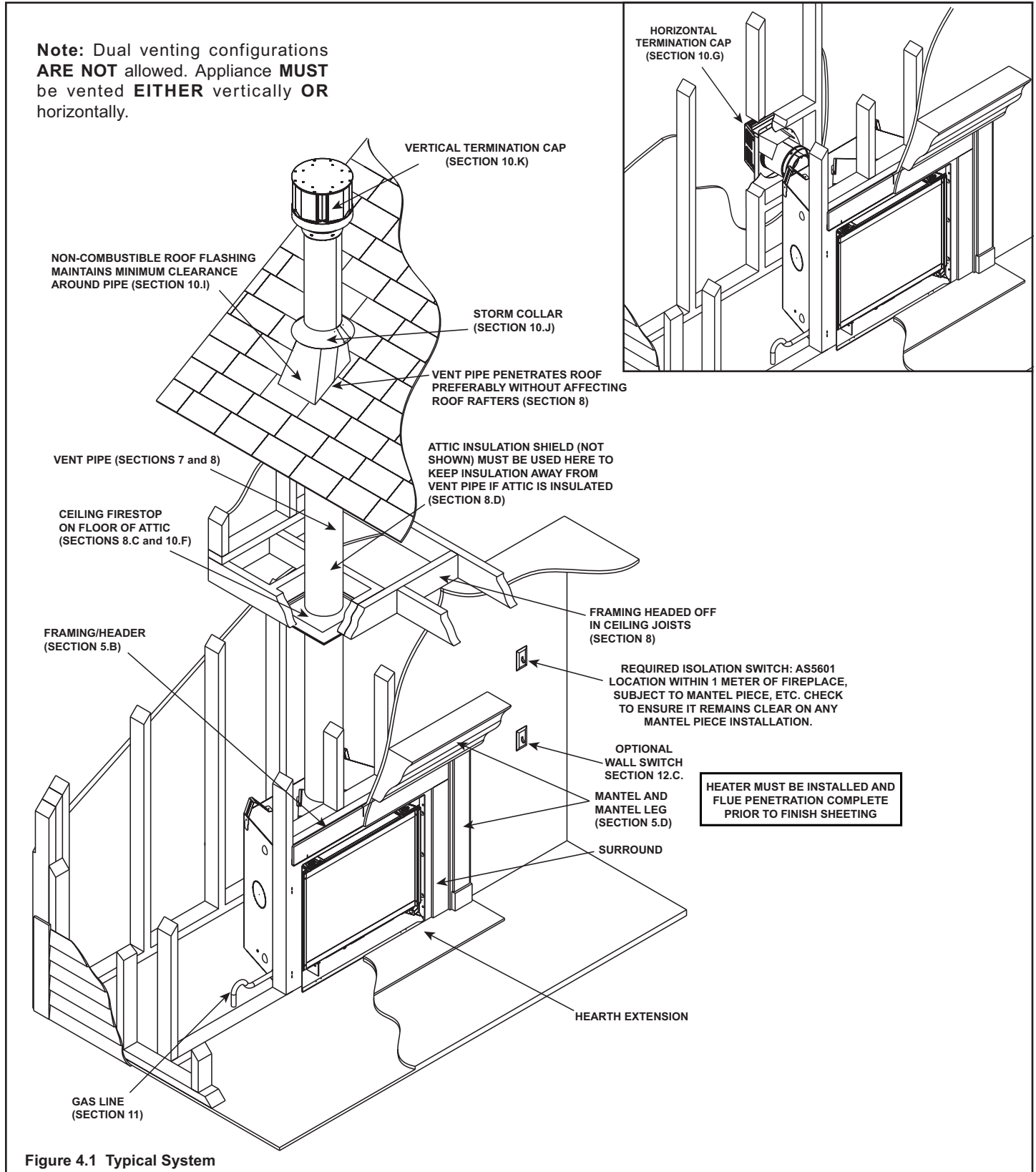

Figure 4.1 Typical System



## B. Design and Installation Considerations

Heat & Glo direct vent gas appliances are designed to operate with all combustion air siphoned from outside of the building and all exhaust gases expelled to the outside of the building. No additional outside air source is required.

Installation **MUST** comply with local, regional, state and national codes and regulations. Consult insurance carrier, local building inspector, fire officials or authorities having jurisdiction over restrictions, installation inspection and permits.

Before installing, determine the following:

- Where the appliance is to be installed.
- The vent system configuration to be used.
- Gas supply piping requirements.
- Electrical wiring requirements.
- Framing and finishing details.
- Whether optional accessories—devices such as a fan, wall switch, or remote control—are desired.

Improper installation, adjustment, alteration, service or maintenance can cause injury or property damage. For assistance or additional information, consult a qualified service technician, service agency or your dealer.

## C. Tools and Supplies Needed

Before beginning the installation be sure that the following tools and building supplies are available.

Tape measure	Framing material
Pliers	High temperature caulking material
Hammer	Phillips screwdriver
Gloves	Framing square
Voltmeter	Electric drill and bits (1/4 in.)
Plumb line	Safety glasses
Level	Reciprocating saw
Manometer	Flat blade screwdriver

Non-corrosive leak check solution  
1/2 - 3/4 in. length, #6 or #8 Self-drilling screws  
One 1/4 in. female connection (for optional fan).

## D. Inspect Appliance and Components

- Carefully remove the appliance and components from the packaging.
- The vent system components and decorative doors and fronts may be shipped in separate packages.
- If packaged separately, the log set and appliance grate must be installed.
- Report to your dealer any parts damaged in shipment, particularly the condition of the glass.
- **Read all of the instructions before starting the installation. Follow these instructions carefully during the installation to ensure maximum safety and benefit.**

**WARNING! Risk of Fire or Explosion!** Damaged parts could impair safe operation. **DO NOT** install damaged, incomplete or substitute components. Keep appliance dry.

Hearth & Home Technologies disclaims any responsibility for, and the warranty will be voided by, the following actions:

- Installation and use of any damaged appliance or vent system component.
- Modification of the appliance or vent system.
- Installation other than as instructed by Hearth & Home Technologies.
- Improper positioning of the gas logs or the glass door.
- Installation and/or use of any component part not approved by Hearth & Home Technologies.

**Any such action may cause a fire hazard.**

**WARNING! Risk of Fire, Explosion or Electric Shock!** **DO NOT** use this appliance if any part has been under water. Call a qualified service technician to inspect the appliance and to replace any part of the control system and/or gas control which has been under water.

# 5 Framing and Clearances

## A. Selecting Appliance Location

When selecting a location for the appliance it is important to consider the required clearances to walls (see Figure 5.1).

**WARNING! Risk of Fire or Burns!** Provide adequate clearance around air openings and for service access. Due to high temperatures, the appliance should be located out of traffic and away from furniture and draperies.

**NOTICE:** Illustrations reflect typical installations and are FOR DESIGN PURPOSES ONLY. Illustrations/diagrams are not drawn to scale. Actual installation may vary due to individual design preference.

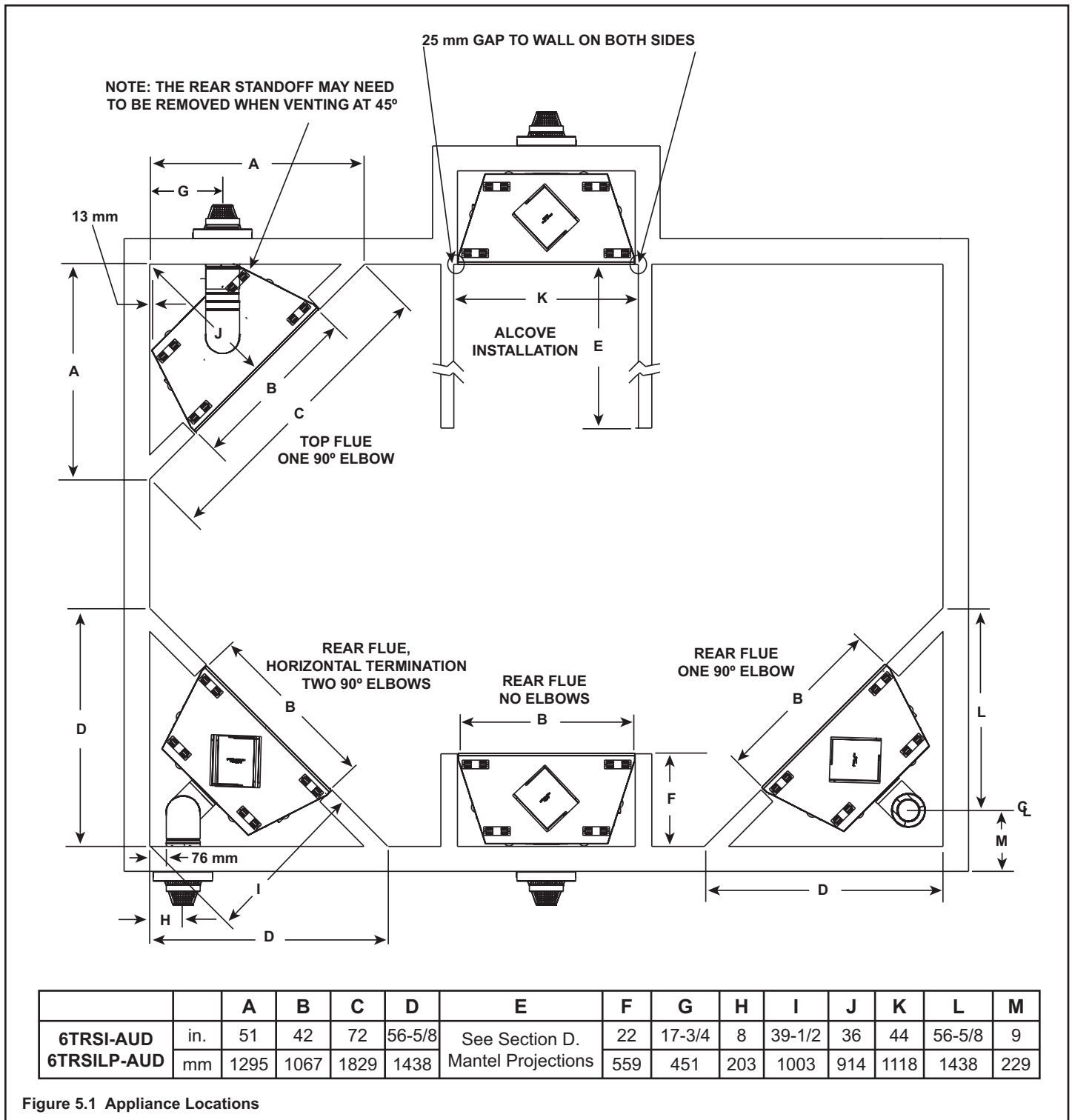

Figure 5.1 Appliance Locations

## B. Constructing the Appliance Chase

A chase is a vertical box-like structure built to enclose the gas appliance and/or its vent system. In cooler climates the vent should be enclosed inside the chase.

**NOTICE:** Treatment of ceiling firestops and wall shield firestops and construction of the chase may vary with the type of building. These instructions are not substitutes for the requirements of local building codes. Therefore, you **MUST** check local building codes to determine the requirements to these steps.

Chases should be constructed in the manner of all outside walls of the home to prevent cold air drafting problems. The chase should not break the outside building envelope in any manner.

Walls, ceiling, base plate and cantilever floor of the chase should be insulated. Vapor and air infiltration barriers should be installed in the chase as per regional codes for the rest of the home. Additionally, in regions where cold air infiltration may be an issue, the inside surfaces may be sheetrocked and taped for maximum air tightness.

**NOTICE:** Measure heater dimensions and verify framing methods and wall covering details, before framing construction begins.

To further prevent drafts, the wall shield and ceiling firestops should be caulked with high temperature caulk to seal gaps. Gas line holes and other openings should be caulked with high temperature caulk or stuffed with unfaced insulation. If the appliance is being installed on a cement surface, a layer of plywood may be placed underneath to prevent conducting cold up into the room.

## C. Clearances

**NOTICE:** Install appliance on hard metal or wood surfaces extending full width and depth. **DO NOT** install directly on carpeting, vinyl, tile or any combustible material other than wood.

**WARNING! Risk of Fire!** Maintain specified air space clearances to appliance and vent pipe:

- Insulation and other materials must be secured to prevent accidental contact.
- The chase must be properly blocked to prevent blown insulation or other combustibles from entering and making contact with fireplace or chimney.
- Failure to maintain airspace may cause overheating and a fire.

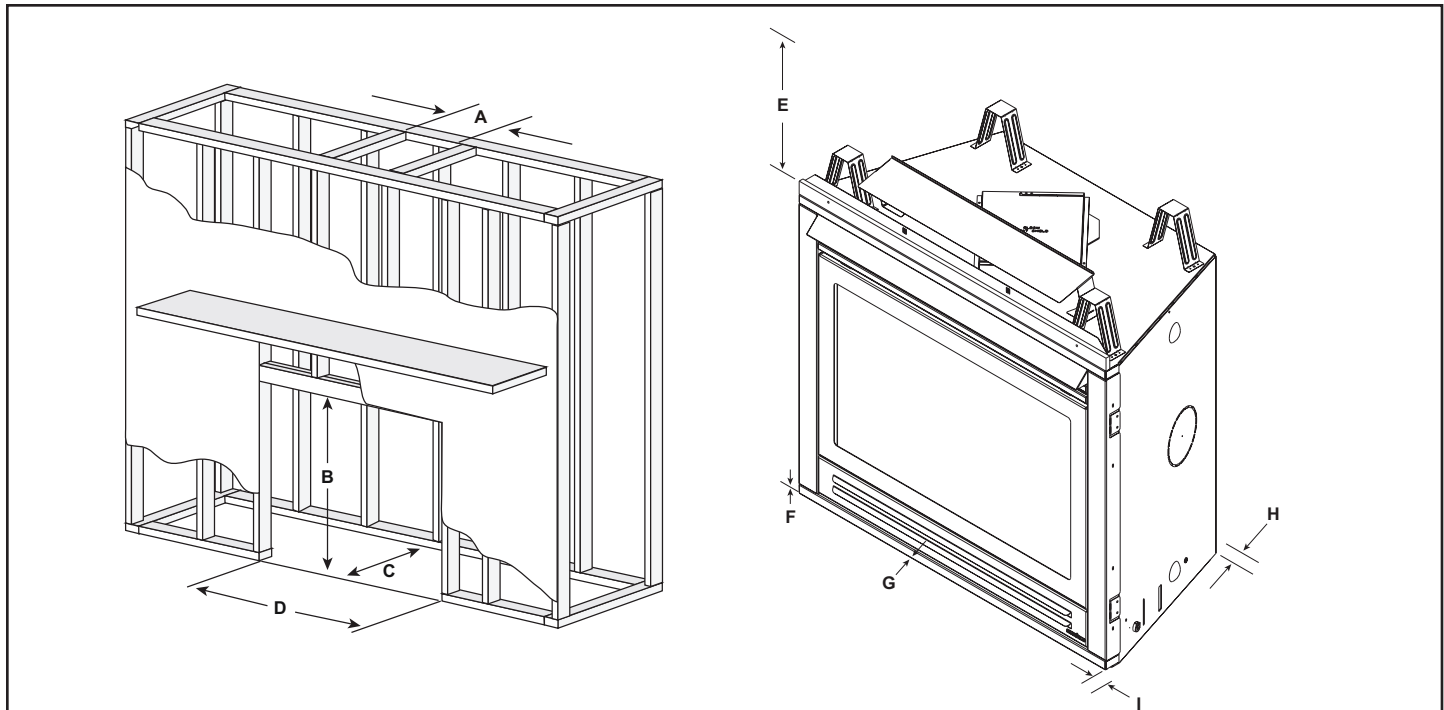

**NOTE:** FRAME OPENING HEIGHT IS GREATER THAN PLASTER OPENING HEIGHT.

		* MINIMUM FRAMING DIMENSIONS									
Models		A	B	C**	D	E	F	G	H	I	J
		Rough Opening (Width)	Rough Opening (Height)	Rough Opening (Depth)	Rough Opening (Width)	Clearance to Ceiling	Combustible Floor	Combustible Flooring	Behind Appliance	Sides of Appliance	Front of Appliance (Glass Front)
6TRSI-AUD	in.	10	40-1/4	22	42-1/8	31	0	0	1/2	1/2	36
6TRSI-LP-AUD	mm	254	1022	560	1070	787	0	0	13	13	914

\* Adjust framing dimensions for interior sheathing (such as sheetrock)

C\*\* Add 12 in. (305 mm) for rear venting with one 90° elbow.

Figure 5.2 Clearances to Combustibles

## D. Mantel and Wall Projections

**WARNING! Risk of Fire!** Comply with all minimum clearances as specified. Framing or finishing material closer than the minimums listed must be constructed entirely of non-combustible materials (i.e., steel studs, concrete board, etc).

### Combustible Mantels

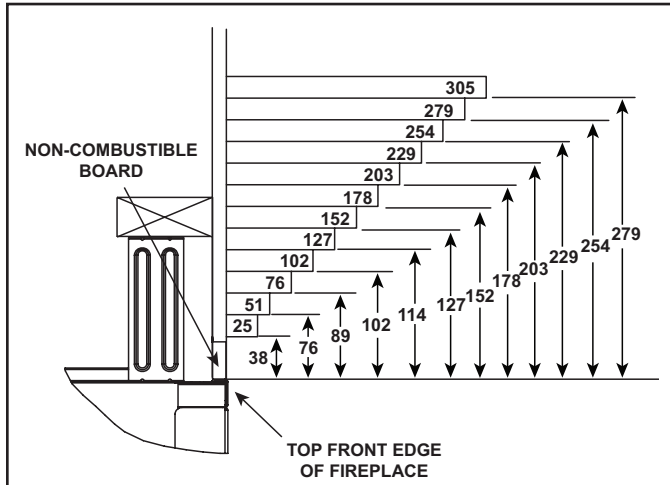

**Note:** All measurements in millimeters.

**Note:** Measurement is taken from top of the opening, NOT the top of the fireplace.

**Figure 5.3 Minimum Vertical and Maximum Horizontal Dimensions of Combustibles**

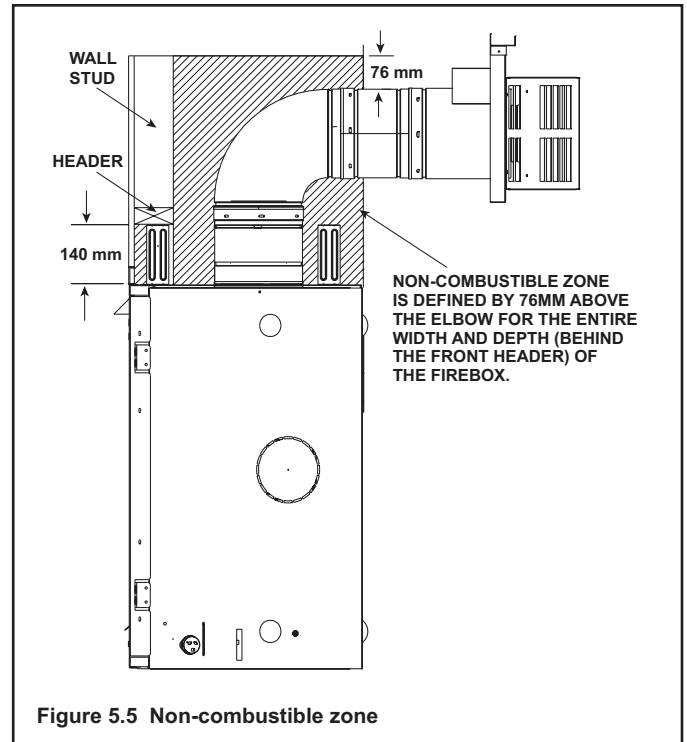

**Figure 5.5 Non-combustible zone**

If joints between the finished walls and the heater surround (top and sides) are sealed, a 150° C minimum sealant material must be used. These joints are not required to be sealed. Only non-combustible material (using 150° C. minimum adhesive, if needed) can be applied as facing to the heater surround. See Figure 5.6.

### Combustible Mantel Legs or Wall Projections

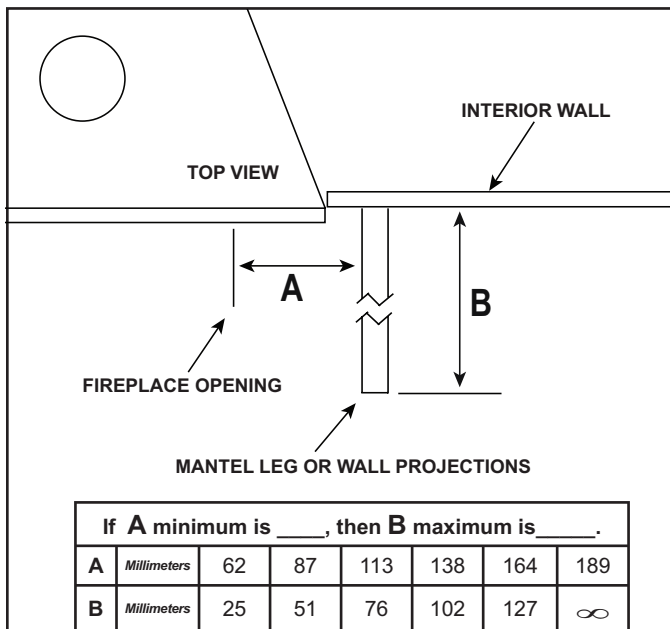

**Figure 5.4 Clearances to Mantel Legs or Wall Projections (Acceptable on both sides of opening.)**

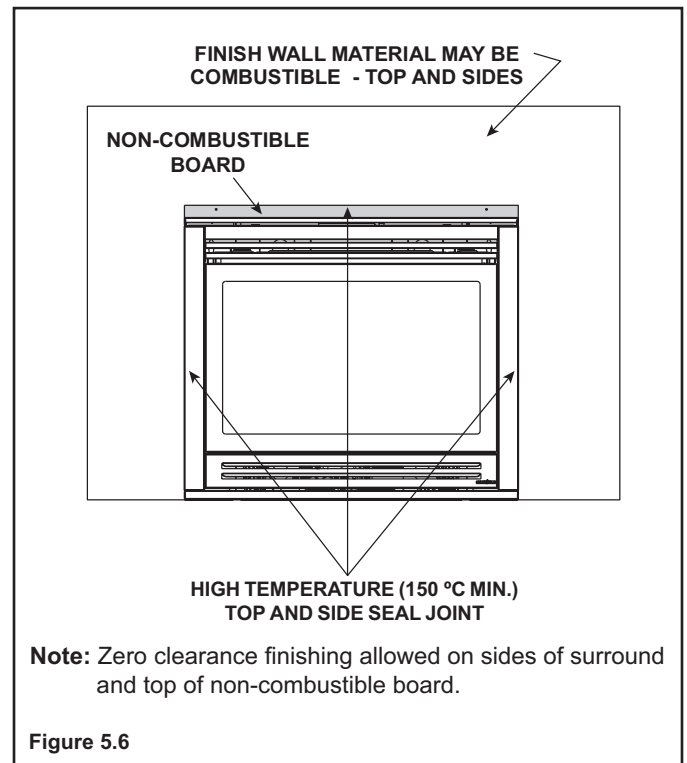

**Figure 5.6**

# 6 Termination Locations

## A. Vent Termination Minimum Clearances

### WARNING

Fire Risk.  
Maintain vent clearance to combustibles as specified.

- **DO NOT** pack air space with insulation or other materials.

Failure to keep insulation or other materials away from vent pipe may cause overheating and fire.

Angle	H (Min.) mm
0°-26.6°	500*
26.6°-30.3°	500*
30.3°-33.7°	500*
33.7°-36.9°	610*
36.9°-39.8°	760
39.8°-42.5°	990
42.5°-45.0°	1220
45.0°-49.4°	1520
49.4°-53.1°	1830
53.1°-56.3°	2130
56.3°-59.0°	2290
59.0°-60.3°	2440

\*910 mm minimum in snow regions

**Figure 6.1 Minimum Height From Roof To Lowest Discharge Opening**

A	B
152 mm (minimum) up to 508 mm	457 mm minimum
508 mm and over	0 mm minimum

\* If using decorative cap cover(s), this distance may need to be increased. Refer to the installation instructions supplied with the decorative cap cover.

\*\* In a staggered installation with both gas and wood terminations, the wood termination cap must be higher than the gas termination cap.

**Figure 6.2 Staggered Termination Caps**

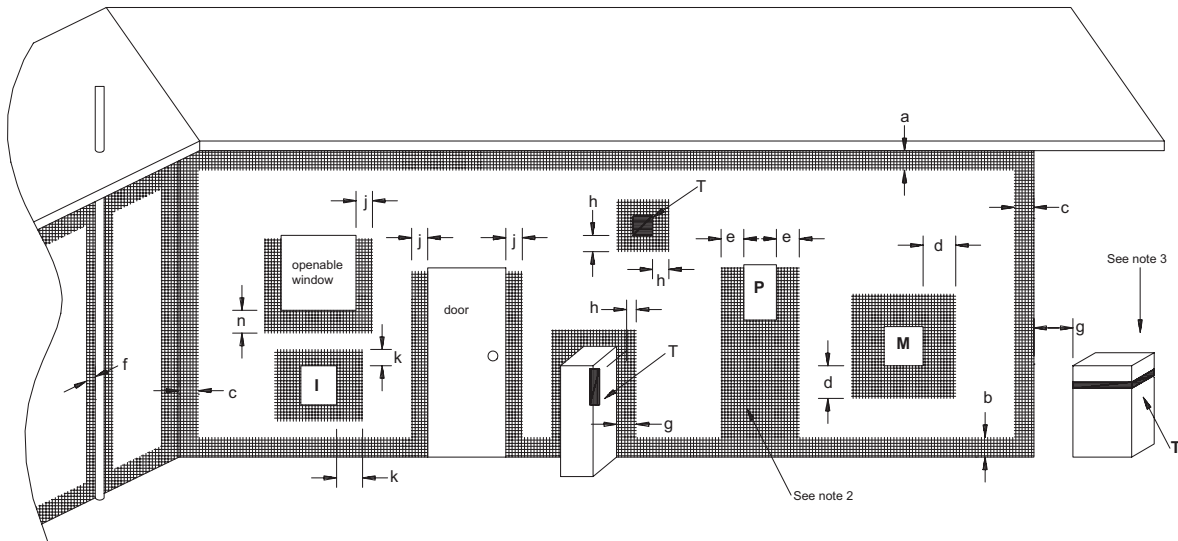

T = Flue terminal  
 I = Mechanical air inlet  
 M = Gas meter  
 P = Electricity meter or fuse box  
 Shading indicates prohibited areas for flue terminals

- |   |  |                            |
|---|--|----------------------------|
| a | - Below eaves, balconies or other projections:   | <b>MIN. CLEARANCE (mm)</b> |
|   | Appliances up to 50 MJ/h input .....   | 300                        |
|   | Appliances over 50 MJ/h input .....  | 500                        |
| b | - From the ground or above a balcony .....   | 300                        |
| c | - From a return wall or external corner .....  | 500                        |
| d | - From a gas meter (M) .....   | 1000                       |
| e | - From an electricity meter or fuse box (P) .....  | 500                        |
| f | - From a drain or soil pipe .....  | 150                        |
| g | - Horizontally from any building structure (unless appliance approved for closer installation) or obstruction facing a terminal .....                      | 500                        |
| h | - From any other flue terminal, cowl, or combustion air intake .....   | 500                        |
| j | - Horizontally from an openable window, door, non-mechanical air inlet, or any other opening into a building, with the exception of sub-floor ventilation: |                            |
|   | Appliances up to 150 MJ/h input .....  | 500                        |
|   | Appliances over 150 MJ/h input .....   | 1500                       |
| k | - From a mechanical air inlet, including a spa blower .....  | 1500                       |
| n | - Vertically below an openable window, non-mechanical air inlet or any other opening into a building, with the exception of sub-floor ventilation .....    | See table below            |

CLEARANCE 'n' (mm)			
Space Heaters	All other appliances		
Up to 50 MJ/h input	Up to 50 MJ/h input	Over 50 MJ/h input and Up to 150 MJ/h input	Over 50 MJ/h input
150	500	1000	1500

- NOTES:**
1. All distances are measured vertically or horizontally along the wall to a point in line with the nearest part of the terminal.
  2. Prohibited area below electricity meter or fuse box extends to ground level.
  3. See clause 5.13.6.6 for restrictions on a flue terminal under a roofed area.
  4. See Appendix J, Figure J1(a) and J2(a) for clearances required from a flue terminal to a LP Gas cylinder. A flue terminal is considered to be a source of ignition.

**MINIMUM CLEARANCES REQUIRED FOR BALANCED FLUE TERMINALS OR THE FLUE TERMINALS OF OUTDOOR APPLIANCES**

**Figure 6.3 Minimum Clearances for Termination**



# 7 Vent Information and Diagrams

## A. Approved Pipe

This appliance is approved for use with Hearth & Home Technologies DVP venting systems. Refer to Section 16.B for vent component information.

**DO NOT** mix pipe, fittings or joining methods from different manufacturers.

The pipe is tested to be run inside an enclosed wall. There is no requirement for inspection openings at each joint within the wall.

**WARNING! Risk of Fire or Asphyxiation.** This appliance requires a separate vent. **DO NOT** vent to a pipe serving a separate solid fuel burning appliance.

## B. Vent Table Key

The abbreviations listed in this vent table key are used in the vent diagrams.

Symbol	Description
V <sub>1</sub>	First section (closest to appliance) of vertical length
V <sub>2</sub>	Second section of vertical length
H <sub>1</sub>	First section (closest to appliance) of horizontal length
H <sub>2</sub>	Subsequent sections of horizontal length

## C. Use of Elbows

Diagonal runs have both vertical and horizontal vent aspects when calculating the effects. Use the rise for the vertical aspect and the run for the horizontal aspect (see Figure 7.1).

Two 45° elbows may be used in place of one 90° elbow. On 45° runs, one foot of diagonal is equal to 216 mm horizontal run and 216 mm vertical run. A length of straight pipe is allowed between two 45° elbows (see Figure 7.1).

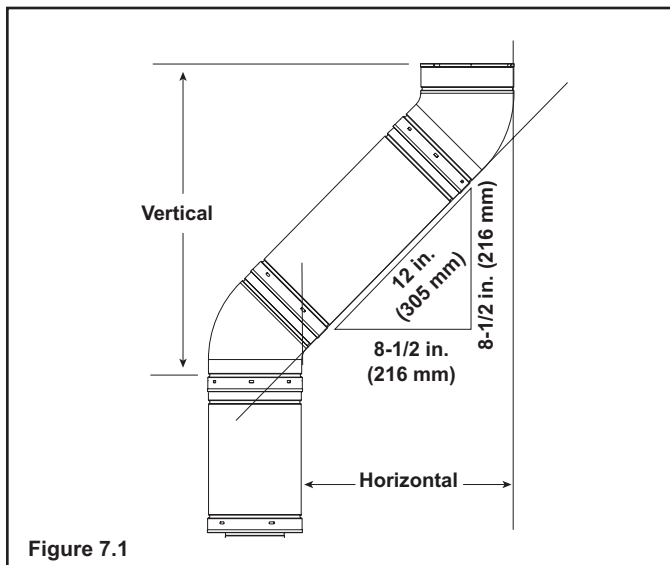

Figure 7.1

## D. Measuring Standards

Vertical and horizontal measurements listed in the vent diagrams were made using the following standards.

- Pipe measurements are shown using the effective length of pipe (see Figure 7.2).
- Measurements are made from the appliance outer wrap, not from the standoffs.
- Horizontal terminations are measured to the outside mounting surface (flange of termination cap).
- Vertical terminations are measured to bottom of termination cap.
- Horizontal pipe installed level with no rise.

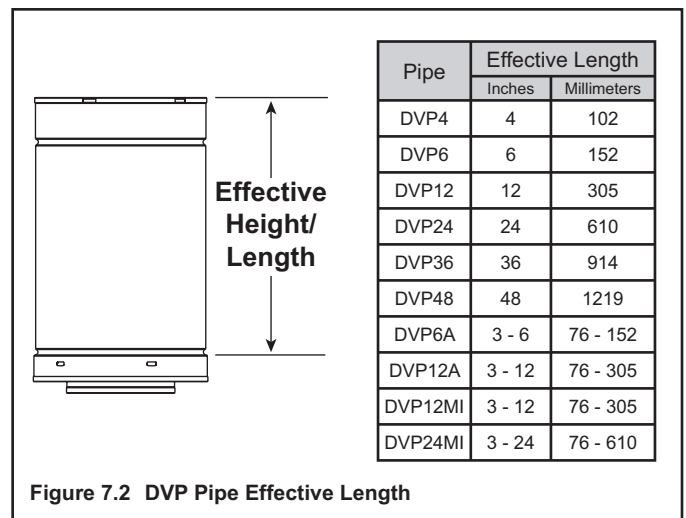

Figure 7.2 DVP Pipe Effective Length

## E. Vent Diagrams

General Rules:

- When penetrating a combustible wall, a wall shield firestop must be installed.
- When penetrating a combustible ceiling, a ceiling firestop must be installed.
- Horizontal runs of vent do not require vertical rise; horizontal runs may be level.

## Top Vent - Horizontal Termination

V <sub>1</sub> Minimum		H <sub>1</sub> Maximum	
Elbow only		Not Allowed	
6 in.	152 mm	3 ft.	610 mm
1 ft.	305 mm	4 ft.	1.22 m
2 ft.	610 mm	7 ft.	2.13 m
3 ft.	914 mm	11 ft.	3.35 m
4 ft.	1.22 m	16 ft.	4.88 m
5 ft.	1.52 m	19 ft.	5.79 m
V <sub>1</sub> + H <sub>1</sub> = 24 ft. (7.32 m) Maximum			

**Note:** For corner installations: A 152 mm section of straight pipe may need to be attached to the appliance before a 90° elbow, to allow the vent pipe to clear the top standoffs.

### WARNING



Fire Risk. Explosion Risk.

Do NOT pack insulation or other combustibles between ceiling firestops.

- ALWAYS maintain specified clearances around venting and firestop systems.
- Install wall shield and ceiling firestops as specified.

Failure to keep insulation or other material away from vent pipe may cause fire.

**Example:** DVP pipe 3 ft. min. vertical = 11 ft. max. horizontal

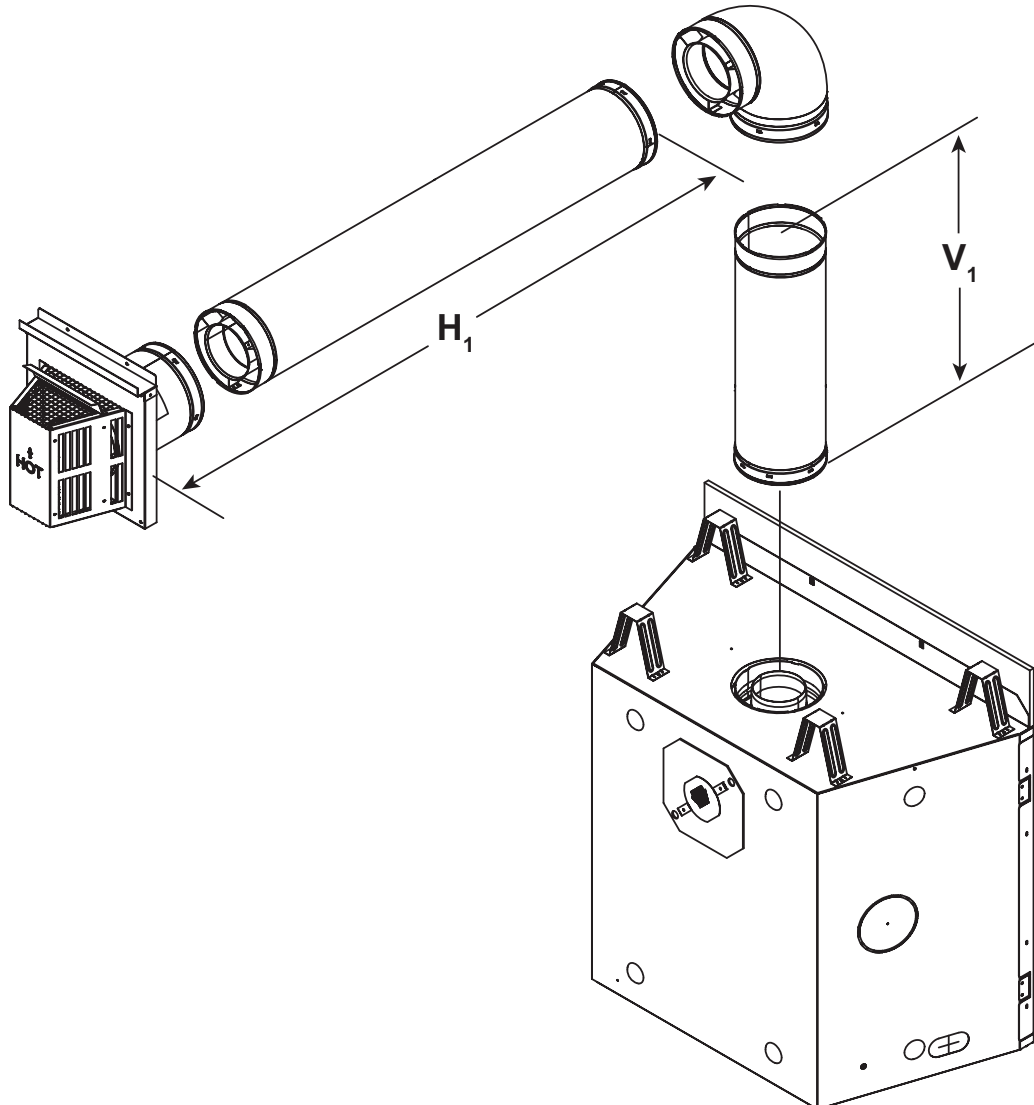

Figure 7.3

## Top Vent - Horizontal Termination - (continued)

### Two Elbows

**Note:** For corner installations: A 152 mm section of straight pipe may need to be attached to the appliance before a 90° elbow, to allow the vent pipe to clear the top standoffs.

V <sub>1</sub> Minimum		H <sub>1</sub> + H <sub>2</sub> Maximum	
Elbow only		Not allowed	
6 in.	152 mm	1 ft.	305 mm
1 ft.	305 mm	2 ft.	610 mm
2 ft.	610 mm	6 ft.	1.83 m
3 ft.	914 mm	10 ft.	3.05 m
4 ft.	1.22 m	14 ft.	4.26 m
5 ft.	1.52 m	16 ft.	4.88 m
V <sub>1</sub> + H <sub>1</sub> + H <sub>2</sub> = 34 ft. (10.36 m) Maximum			
H <sub>1</sub> + H <sub>2</sub> = 16 ft. (4.88 m) Maximum			

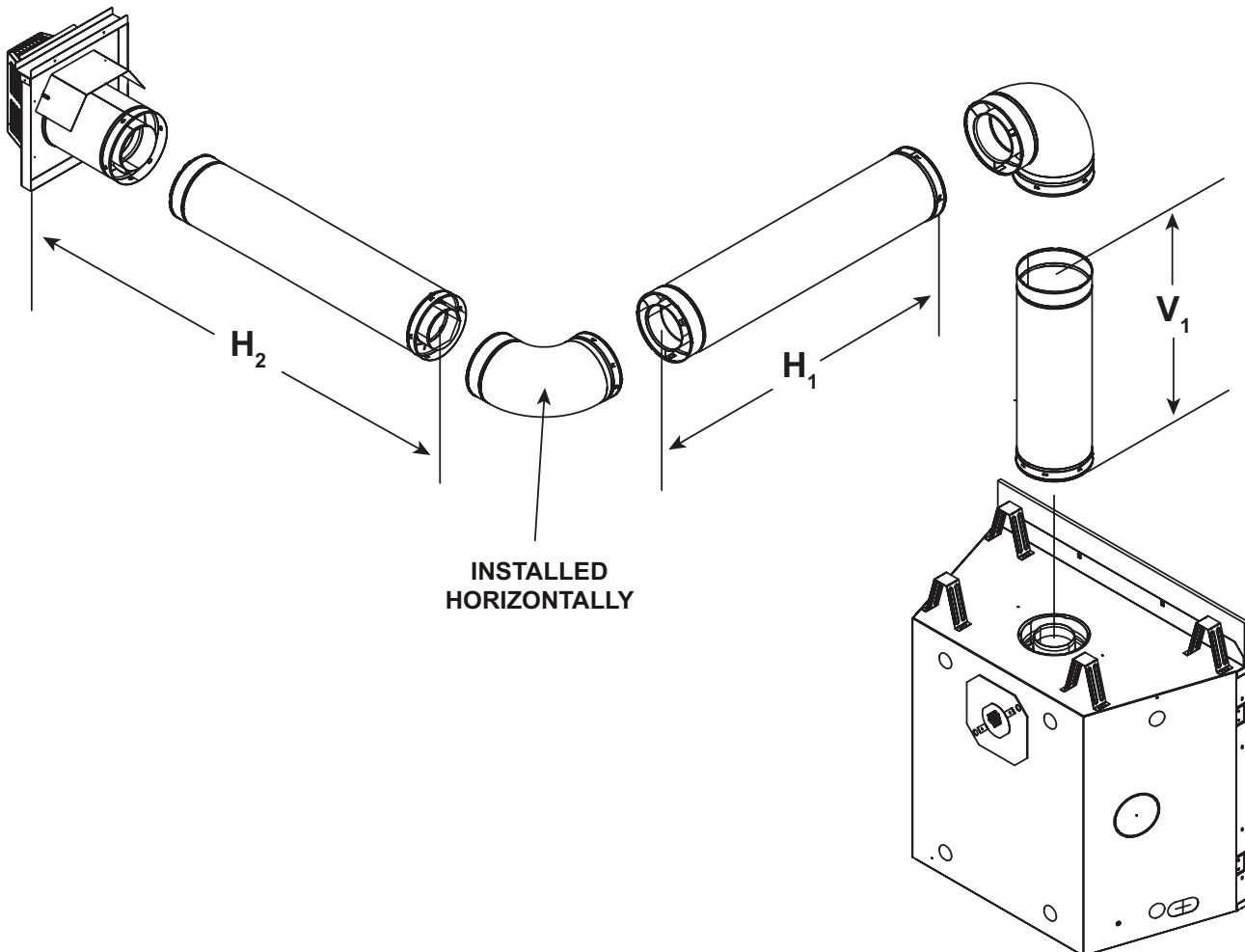

Figure 7.4

### Three Elbows

V <sub>1</sub> Min.		H <sub>1</sub> Max.		V <sub>2</sub> Min.		H <sub>2</sub> Max.	
Elbow only		1 ft.	305 mm	0 in.	0 mm	1 ft.	305 mm
6 in.	152 mm	2 ft.	610 mm	6 in.	152 mm	2 ft.	610 mm
1 ft.	305 mm	3 ft.	914 mm	1 ft.	305 mm	3 ft.	914 mm
2 ft.	610 mm	7 ft.	2.13 m*	2 ft.	610 mm	7 ft.	2.13 m*
3 ft.	914 mm	9 ft.	2.74 m	3 ft.	914 mm	9 ft.	2.74 m
4 ft.	1.22 m	12 ft. *	3.66 m*	4 ft.	1.22 m	12 ft. *	3.66 m*

\*H<sub>1</sub> + H<sub>2</sub> = 12 ft. (3.66 m) Maximum      V<sub>1</sub> + V<sub>2</sub> + H<sub>1</sub> + H<sub>2</sub> = 32 ft. (9.75 m) Maximum

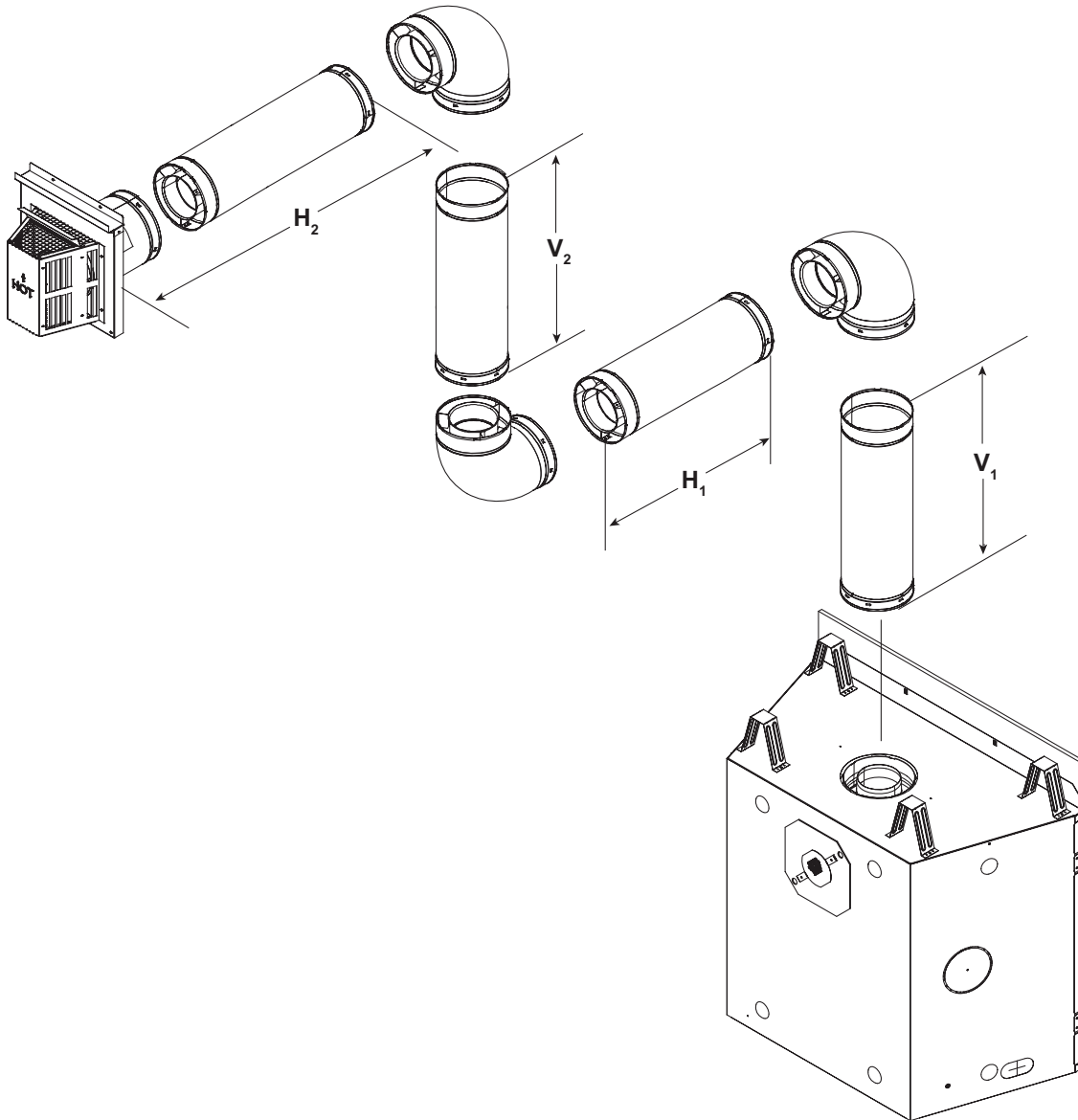

Figure 7.5

## Top Vent - Vertical Termination

MODEL	FLUE TERMINATION APPROVALS
6TRSI-AUD 6TRSILP-AUD	DVP-TVHW

This model is approved to use DVP-Series flue pipe components. A **DVP-TVHW** vertical Termination Cap must be used to terminate flue systems in a vertical position.

Approved flue system components are labeled for identification. **NO OTHER FLUE SYSTEMS OR COMPONENTS MAY BE USED.** Detailed installation instructions are included with each flue termination kit and should be used in conjunction with this manual.

**WARNING! Risk of Fire!** This gas appliance and flue assembly must be flued directly to the outside and must never be attached to a chimney serving a separate solid fuel burning appliance. Each gas appliance must use a separate flue system—common flue systems are prohibited.

→ **WARNING! Risk of Fire!** DO NOT apply combustible materials beyond the minimum clearances. Comply with all minimum clearances to combustibles as specified in this manual. Overlapping material could ignite and will interfere with proper operation of doors and louvers.

- Horizontal sections 3 inches (762 mm) from the top of the pipe.
- Horizontal sections 2-1/2 inches (635 mm) at wall shield firestops.
- Horizontal sections 1 inches (254 mm) from sides and bottom of the pipe.
- Vertical sections 1 inches (254 mm) on all sides of pipe.

Failure to keep insulation or other material away from vent pipe may cause over heating and fire.

For alternative installations, other than depicted, contact your dealer for further information.

## Straight Up Vertical Flue System

Figure 7.6 shows straight up vertical flue system approved for use on this model.

If the heater installation requires a vertical flue exceeding 4.5 m above the unit with no horizontal flue or elbows a vertical flue restrictor must be installed (see Figure 7.7).

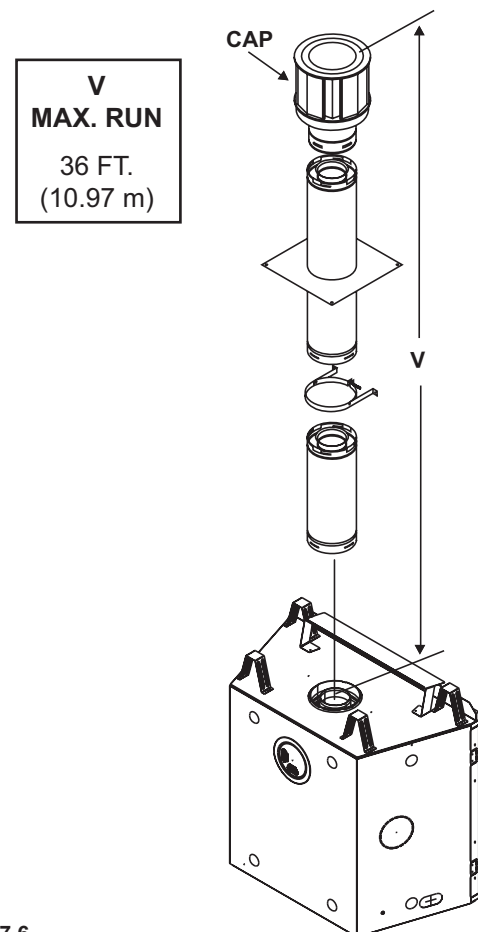

Figure 7.6

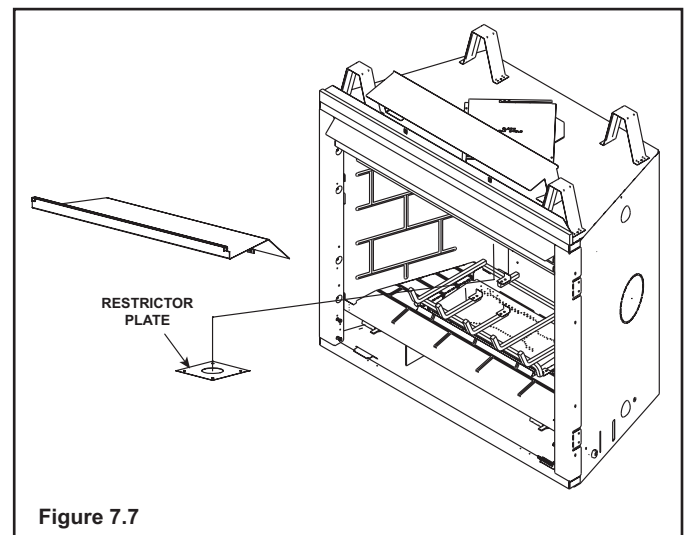

Figure 7.7

**MODEL**  
6TRSI-AUD  
6TRSILP-AUD

**FLUE TERMINATION APPROVALS**  
DVP-TRAP2 HORIZONTAL TERMINATION CAP  
DVP-FBHT HORIZONTAL TERMINATION CAP  
DVP-TVHW VERTICAL TERMINATION CAP

## Flue System Approvals And Installations

These models have flue starting collars on both the top and the back of the unit. Depending upon the installation, decide which ONE set of starting collars will be used to attach the flue system. The starting collar sealing cap must remain on the starting collar NOT used.

These models use DVP series direct flue components when using the TOP flue collars and DVP-series direct flue components when using the REAR flue collars.

Approved flue system components are labeled for identification. **NO OTHER FLUEING SYSTEMS OR COMPONENTS MAY BE USED.** Detailed installation instructions are included with each flue termination kit and should be used in conjunction with this manual. Figure 7.8 shows flue system components and terminations.

### Identifying Flue Components

The flue systems installed on this gas heater may include one, two, or three 90° elbow assemblies. The relationships of vertical rise to horizontal run in flue configurations using 90° elbows **MUST BE** strictly adhered to. The rise to run relationships are shown in the flueing drawings and tables on the next few pages.

**WARNING! Risk of Fire!** This gas appliance and flue assembly must flue directly to the outside and must never be attached to a chimney serving a separate solid fuel burning appliance. Each gas appliance must use a separate flue system-common flue systems are prohibited.

**WARNING! Risk of Fire!** DO NOT apply combustible materials beyond the minimum clearances. Comply with all minimum clearances to combustibles as specified in this manual. Overlapping material could ignite and will interfere with proper operation of doors and louvers.

- Horizontal sections 3 inches (762 mm) from the top of the pipe.
- Horizontal sections 2-1/2 inches (635 mm) at wall shield firestops.
- Horizontal sections 1 inches (254 mm) from sides and bottom of the pipe.
- Vertical sections 1 inches (254 mm) on all sides of pipe.

Failure to keep insulation or other material away from vent pipe may cause over heating and fire.

For alternative installations, other than depicted, contact your dealer for further information.

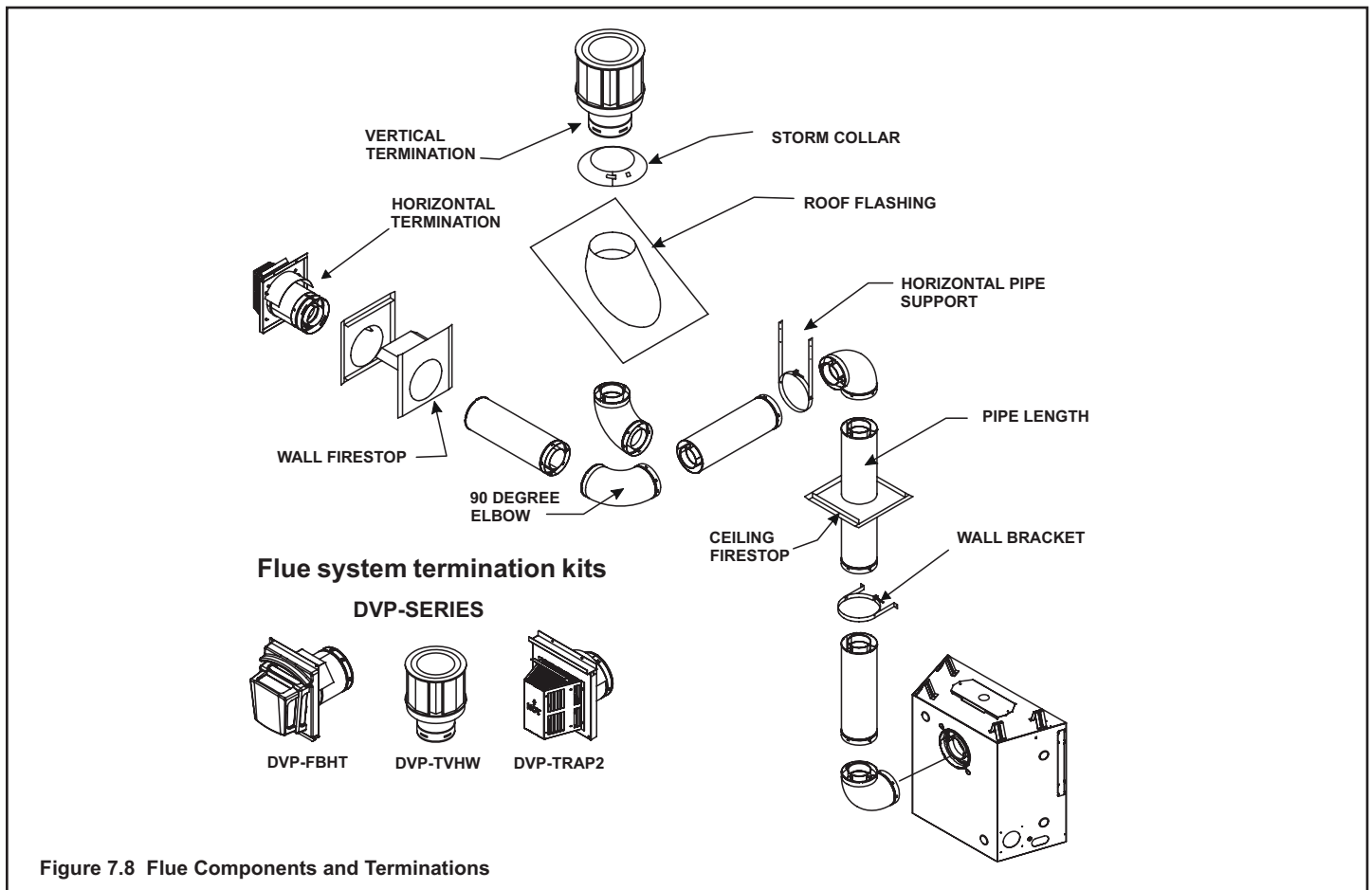
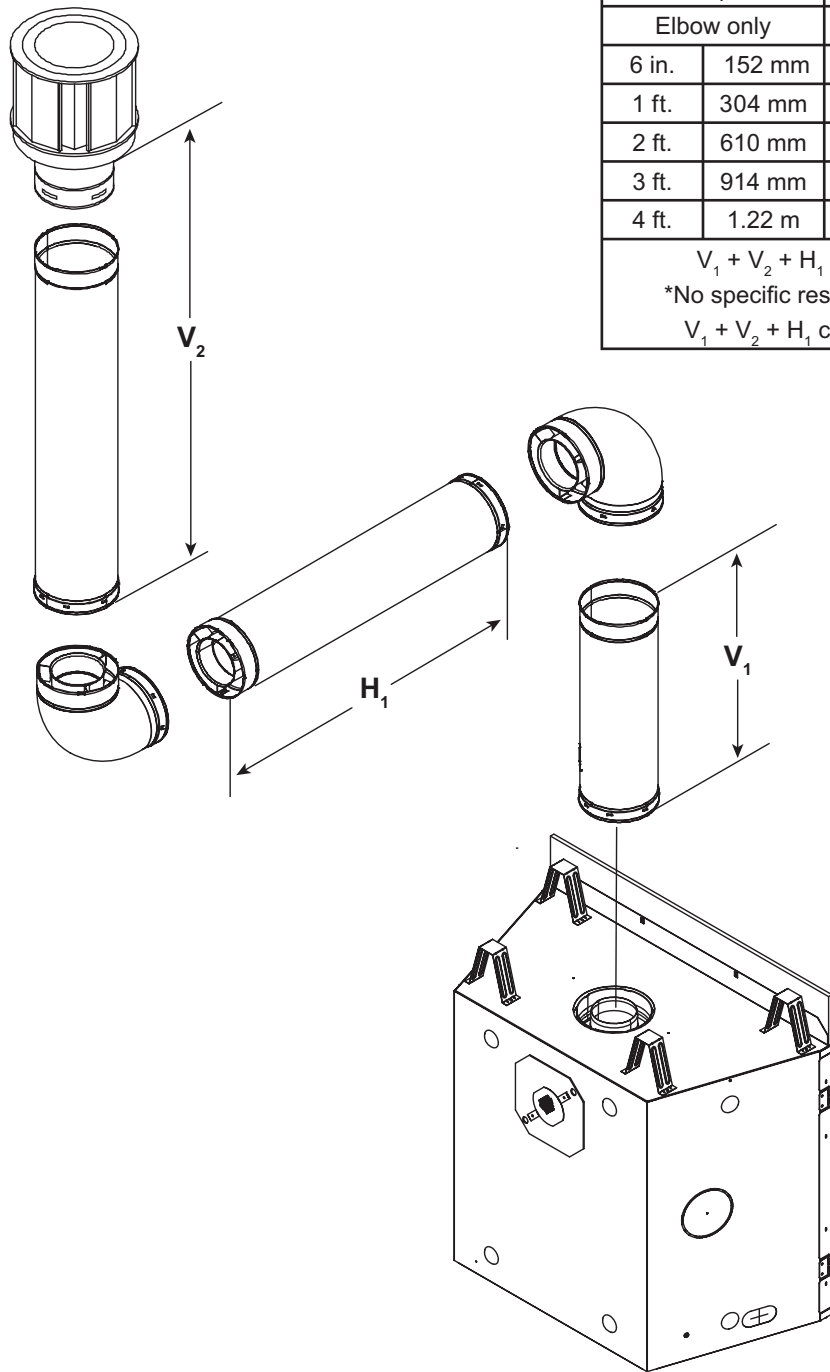

Figure 7.8 Flue Components and Terminations



# Two Elbows



$V_1$		$H_1$ Maximum		$V_2$	$V_1 + V_2$ Min.	
Elbow only		2 ft.	610 mm	*	*	*
6 in.	152 mm	3 ft.	914 mm	*	*	*
1 ft.	304 mm	4 ft.	1.22 m			
2 ft.	610 mm	8 ft.	2.44 m	*	*	*
3 ft.	914 mm	12 ft.	3.66 m	*	*	*
4 ft.	1.22 m	16 ft.	4.88 m	*	*	*
$V_1 + V_2 + H_1 = 36 \text{ ft. (10.97 m)}$ Maximum *No specific restrictions on this value EXCEPT $V_1 + V_2 + H_1$ cannot exceed 36 ft. (10.97 m)						

Figure 7.9

# Top Vent - Vertical Termination - (continued)

## Three Elbows

$V_1$		$H_1 + H_2$		$V_2$	$V_1 + V_2$ Minimum		$H_1 + H_2$ Maximum	
Elbow only		1 ft.	305 mm	*	*	*	1 ft.	305 mm
6 in.	152 mm	2 ft.	610 mm	*	*	*	2 ft.	610 mm
1 ft.	305 mm	3 ft.	914 mm	*	*	*	3 ft.	914 mm
2 ft.	610 mm	7 ft.	2.13 m	*	*	*	7 ft.	2.13 m
3 ft.	914 mm	9 ft.	2.74 m	*	*	*	9 ft.	2.74 m
4 ft.	1.22 m	12 ft.	3.66 m	*	*	*	12 ft.	3.66 m
$H_1 + H_2 = 12$ ft. (3.66 m) Maximum				$V_1 + V_2 + H_1 + H_2 = 32$ ft. (9.75 m) Maximum				

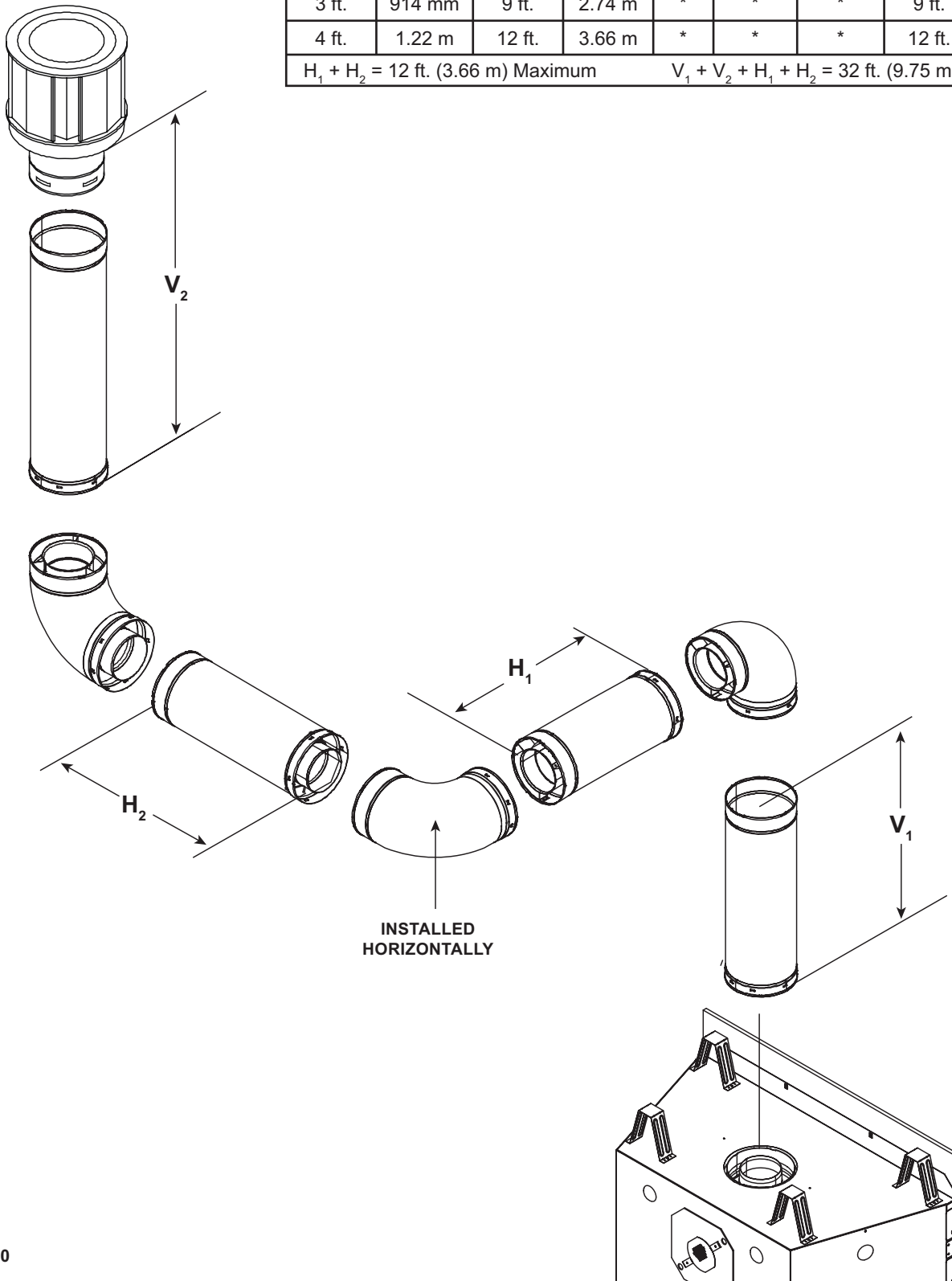

Figure 7.10

## Rear Vent - Horizontal Termination

### No Elbow

H <sub>1</sub> Minimum	H <sub>1</sub> Maximum
6-1/2 in. (165 mm)	18 in (457 mm)

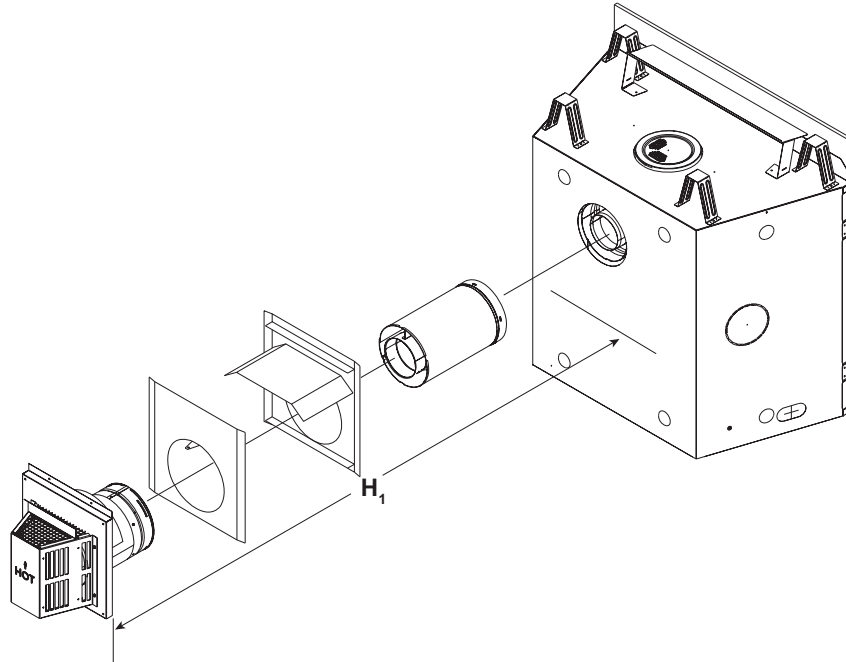

Figure 7.11

### One 45° Elbow

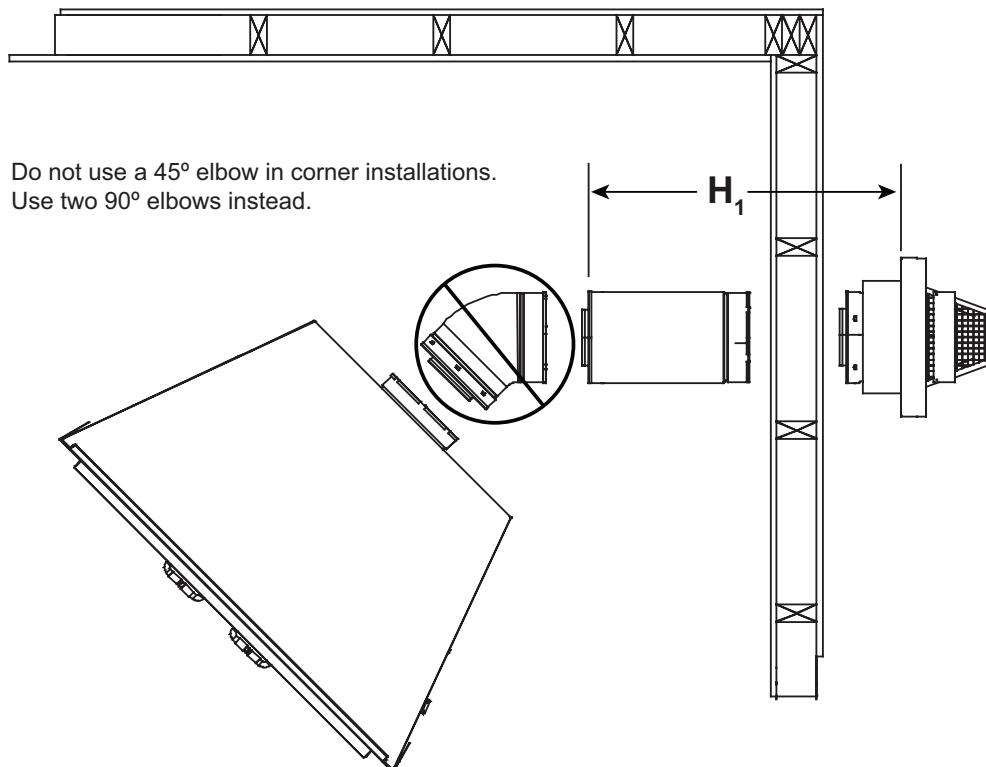

Figure 7.12

## Rear Vent - Horizontal Termination - (continued)

### Two Elbows

H <sub>1</sub> Maximum		V <sub>1</sub> Minimum		H <sub>2</sub>		H <sub>1</sub> + H <sub>2</sub> Maximum	
6 in.	152 mm	Back to Back 90° Elbows		1 ft.	305 mm	1-1/2 ft.	457 mm
1 ft.	305 mm	6 in.	152 mm	1-1/2 ft.	457 mm	2-1/2 ft.	762 mm
2 ft.	610 mm	1 ft.	305 mm	2 ft.	610 mm	4 ft.	1.22 m
3 ft.	914 mm	2 ft.	610 mm	3 ft.	914 mm	6 ft.	1.83 m
4 ft.	1.22 m	3 ft.	914 mm	7 ft.	2.13 m	10 ft.	3.05 m
5 ft.	1.52 m	4 ft.	1.22 m	11 ft.	3.35 m	15 ft.	4.57 m
5 ft.	1.52 m	5 ft.	1.52 m	11 ft.	3.35 m	15 ft.*	4.57 m*

$V_1 + H_1 + H_2 = 36 \text{ ft. (10.97 m) Maximum}$      $H_1 = 5 \text{ ft. (1.52 m) Maximum}$   
 $V_1 = 20 \text{ ft. (6.09 m) Maximum}$      $*H_1 + H_2 = 15 \text{ ft. (4.57 m) Maximum}$

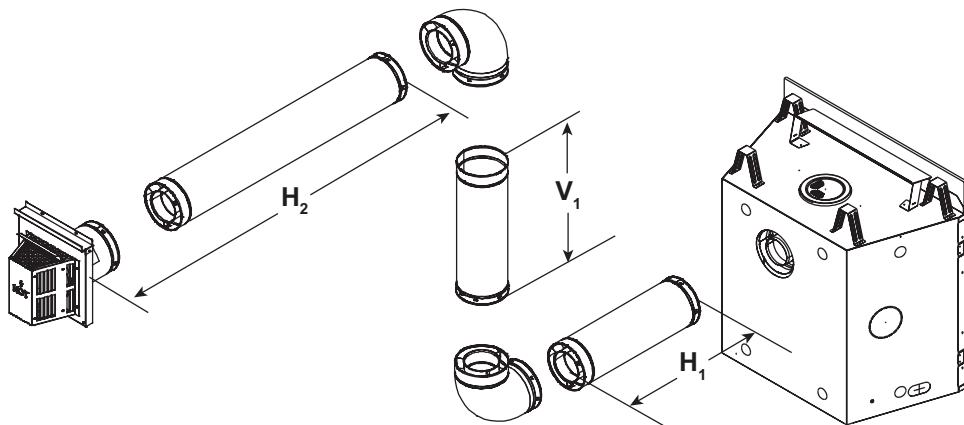

Figure 7.13

### Three Elbows

H <sub>1</sub> Maximum		V <sub>1</sub> Minimum		H <sub>2</sub> + H <sub>3</sub>		H <sub>1</sub> + H <sub>2</sub> + H <sub>3</sub> Max.	
0 ft.	0 mm	Back to Back 90° Elbows		1 ft.	305 mm	1 ft.	305 mm
1 ft.	305 mm	6 in.	152 mm	1-1/2 ft.	457 mm	2-1/2 ft.	762 mm
2 ft.	610 mm	1 ft.	305 mm	2 ft.	610 mm	4 ft.	1.22 m
3 ft.	914 mm	2 ft.	610 mm	3 ft.	914 mm	6 ft.	1.83 m
4 ft.	1.22 m	3 ft.	914 mm	7 ft.	2.13 m	10 ft.	3.05 m
5 ft.	1.52 m	4 ft.	1.22 m	12 ft.	3.66 m	15 ft.	4.57 m
5 ft.	1.52 m	5 ft.	1.52 m	17 ft.	5.18 m	20 ft.	6.09 m

$V_1 + H_1 + H_2 + H_3 = 32 \text{ ft. (9.75 m) Maximum}$      $H_1 = 3 \text{ ft. (914 mm) Maximum}$   
 $H_1 + H_2 + H_3 = 12 \text{ ft. (3.66 m) Maximum}$

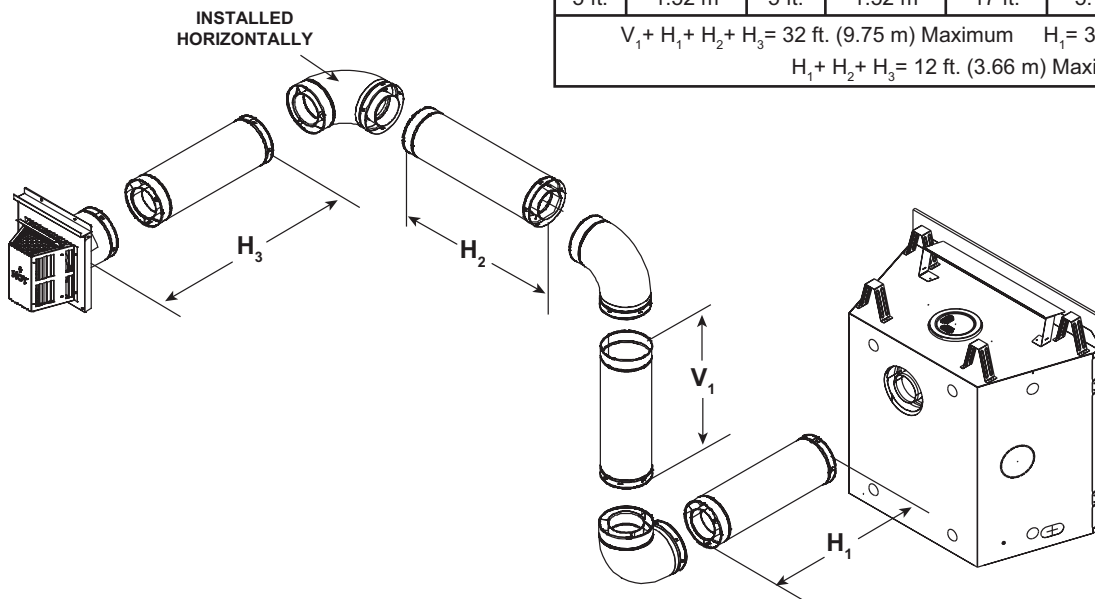
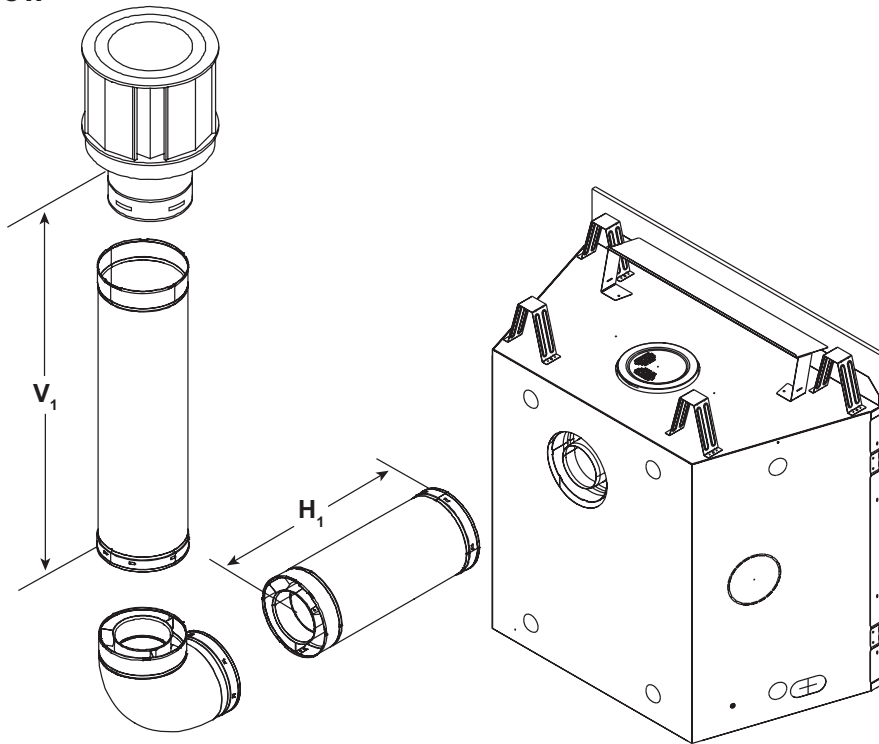

Figure 7.14

## Rear Vent - Vertical Termination

### One Elbow



$V_1$ Minimum		$H_1$ Maximum	
1 ft.	305 mm	2 ft.	610 mm
2 ft.	610 mm	2 ft.	610 mm
3 ft.	914 mm	4 ft.	1.22 m
4 ft.	1.22 m	6 ft.	1.83 m
5 ft.	1.52 m	8 ft.	2.44 m
$V_1 + H_1 = 32$ ft. (9.75 m) Maximum			
$H_1 = 8$ ft. (2.44 m) Maximum			

Figure 7.15

### Two Elbows

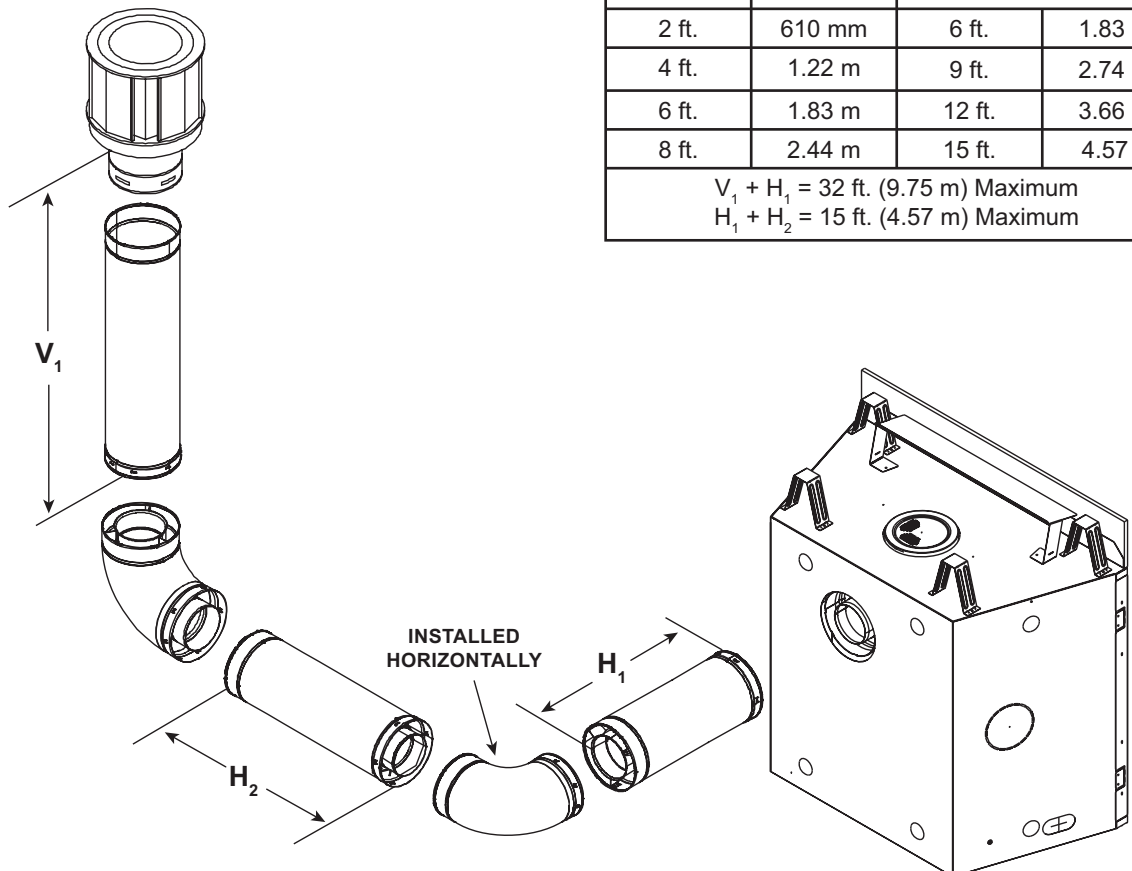

$V_1$ Minimum		$H_1 + H_2$ Maximum	
3 ft.	914 mm	Back to Back 90° Elbows	
2 ft.	610 mm	6 ft.	1.83 m
4 ft.	1.22 m	9 ft.	2.74 m
6 ft.	1.83 m	12 ft.	3.66 m
8 ft.	2.44 m	15 ft.	4.57 m
$V_1 + H_1 = 32$ ft. (9.75 m) Maximum			
$H_1 + H_2 = 15$ ft. (4.57 m) Maximum			

Figure 7.16

## Rear Vent - Vertical Termination - (continued)

### Three Elbows

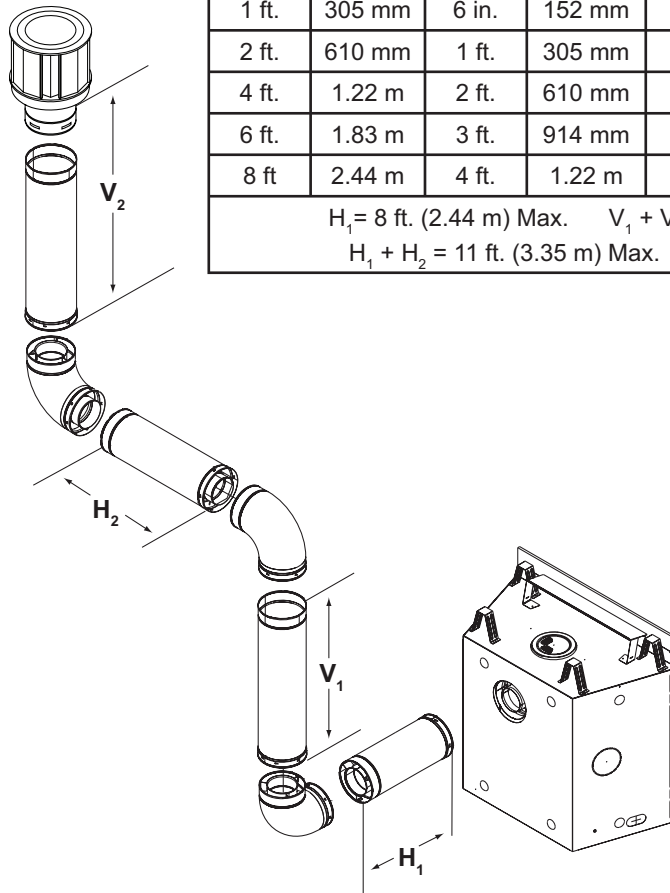

H <sub>1</sub> Maximum		V <sub>1</sub> Minimum		H <sub>2</sub>		H <sub>1</sub> + H <sub>2</sub> Maximum		V <sub>2</sub>
1 ft.	305 mm	6 in.	152 mm	1 ft.	305 mm	2 ft.	610 mm	*
2 ft.	610 mm	1 ft.	305 mm	4 ft.	1.22 m	3 ft.	914 mm	*
4 ft.	1.22 m	2 ft.	610 mm	6 ft.	1.83 m	6 ft.	1.83 m	*
6 ft.	1.83 m	3 ft.	914 mm	8 ft.	2.44 m	11 ft.	3.35 m	*
8 ft.	2.44 m	4 ft.	1.22 m	8 ft.	2.44 m	11 ft.	3.35 m	*

$H_1 = 8 \text{ ft. (2.44 m) Max.}$      $V_1 + V_2 + H_1 + H_2 = 32 \text{ ft. (9.75 m) Max.}$   
 $H_1 + H_2 = 11 \text{ ft. (3.35 m) Max.}$      $V_1 + V_2 = 20 \text{ ft. (6.09 m) Max.}$

Figure 7.17

### Three Elbows

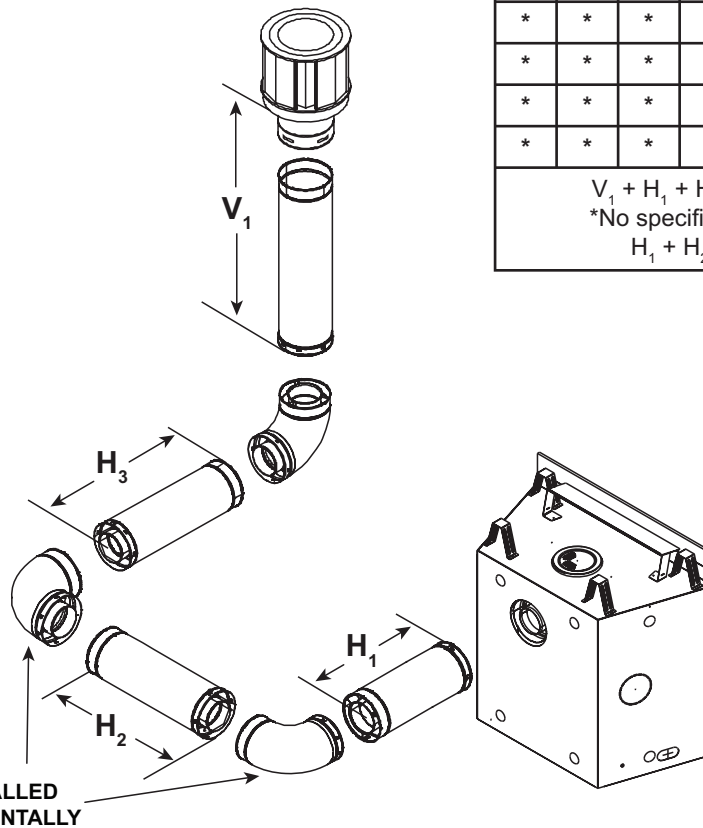

H <sub>1</sub>	H <sub>2</sub>	H <sub>3</sub>	V <sub>1</sub> Minimum		H <sub>1</sub> + H <sub>2</sub> + H <sub>3</sub> Maximum	
*	*	*	8 ft.	2.44 m	6 ft.	1.83 m
*	*	*	9 ft.	2.74 m	7 ft.	2.13 m
*	*	*	10 ft.	3.05 m	8 ft.	2.44 m
*	*	*	10 ft.	3.05 m	8 ft.	2.44 m

$V_1 + H_1 + H_2 + H_3 = 36 \text{ ft. (10.97 m) Maximum}$   
 \*No specific restrictions on this value EXCEPT  
 $H_1 + H_2 + H_3 = 8 \text{ ft. (2.44 m) Maximum}$

Figure 7.18

INSTALLED  
HORIZONTALLY



# 8 Vent Clearances and Framing

## A. Pipe Clearances to Combustibles

**WARNING! Risk of Fire! Maintain air space clearance to vent. DO NOT pack insulation or other combustibles:**

- Between ceiling firestops
- Between wall shield firestops
- Around vent system

Failure to keep insulation or other material away from vent pipe may cause over heating and fire.

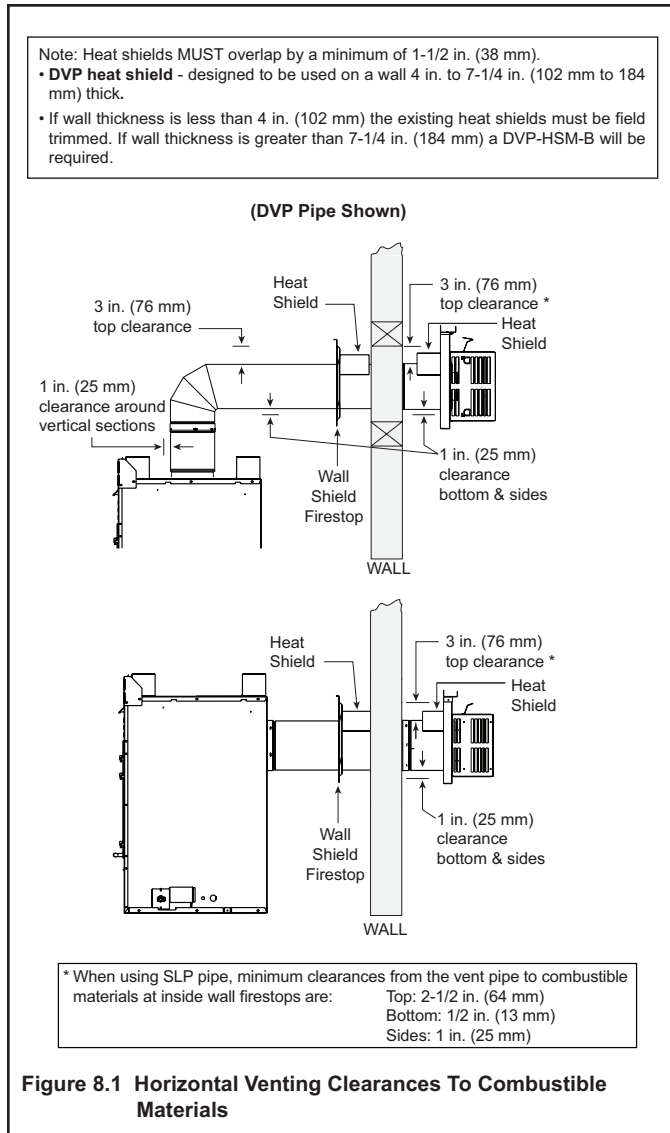

## B. Wall Penetration Framing

### Combustible Wall Penetration

Whenever a combustible wall is penetrated, you must frame a hole for the wall shield firestop(s). The wall shield firestop maintains minimum clearances and prevents cold air infiltration.

- The opening must be framed on all four sides using the same size framing materials as those used in the wall construction.
- DVP pipe - A wall shield firestop is required on one side only on interior walls. If your local inspector requires a wall shield firestop on both sides, then both wall shield firestops must have a heat shield (refer to Section 16.B.) attached to them.
- See Section 10 for information for regarding the installation of a horizontal termination cap.

### Non-Combustible Wall Penetration

If the hole being penetrated is surrounded by noncombustible materials such as concrete, a hole with diameter one inch greater than the pipe is acceptable.

Whenever a non-combustible wall is penetrated, the wall shield firestop is only required on one side and no heat shield is necessary.

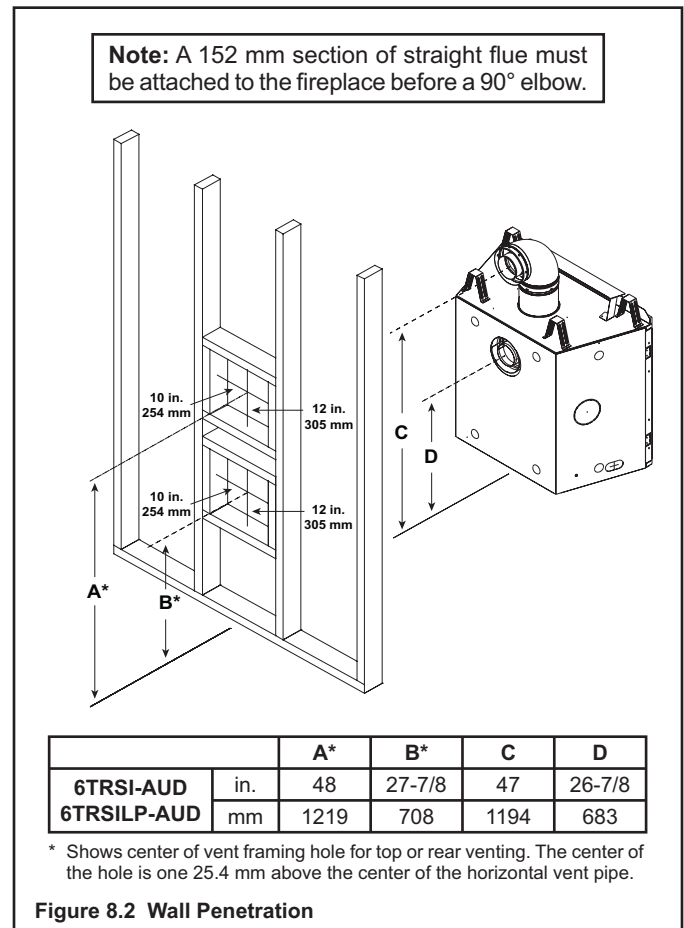

### C. Install the Ceiling Firestop

A ceiling firestop **MUST** be used between floors and attics.

- **DVP pipe only** - Frame an opening 10 in. by 10 in. (254 mm by 254 mm) whenever the vent penetrates a ceiling/floor (see Figure 8.3).
- Frame the area with the same sized lumber as used in ceiling/floor joist.
- The ceiling firestop may be installed above or below the ceiling joists when installed with a attic insulation shield. It must be under joists between floors that are not insulated. Refer to Figure 8.4.
- Secure with three fasteners on each side.

**WARNING! Risk of Fire! DO NOT pack insulation around the vent. Insulation must be kept back from the pipe to prevent overheating.**

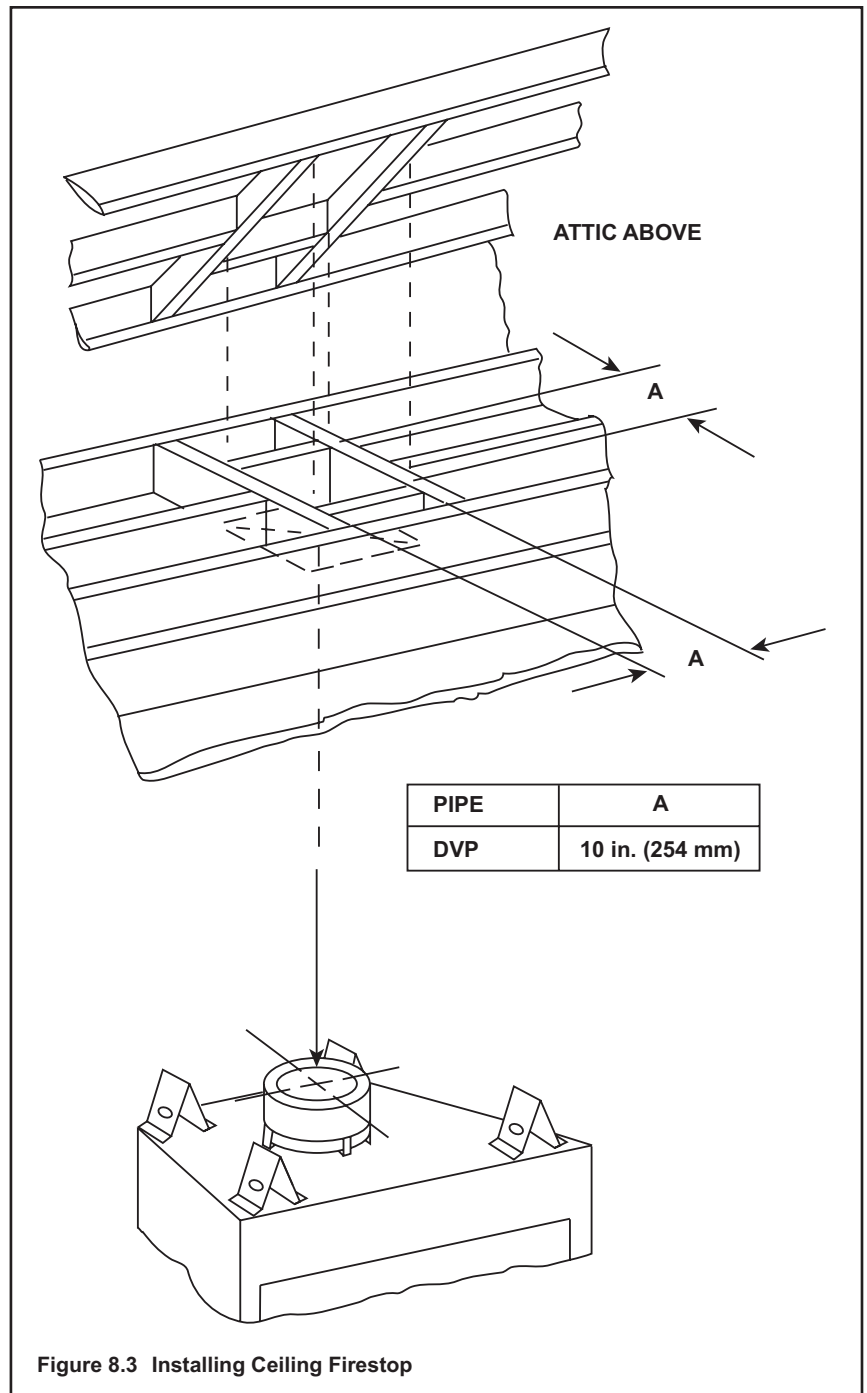

Figure 8.3 Installing Ceiling Firestop

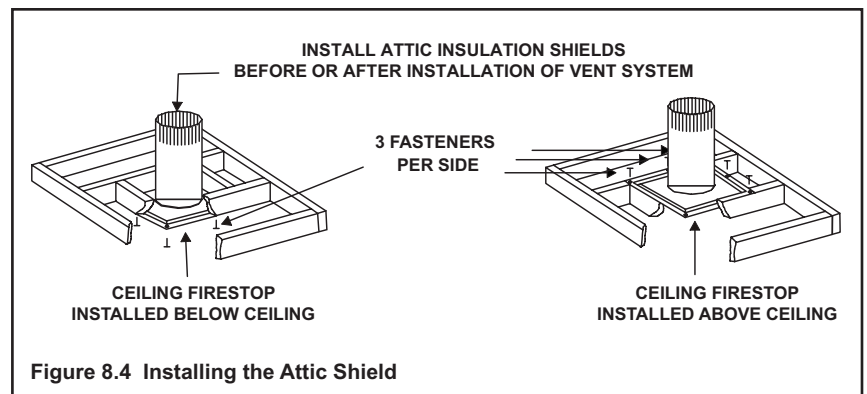

Figure 8.4 Installing the Attic Shield

## D. Install Attic Insulation Shield

**WARNING! Fire Risk. DO NOT** allow loose materials or insulation to touch vent. Hearth & Home Technologies Inc. requires the use of an attic shield.

→ An attic shield constructed of 26 gauge minimum metal that extends at least 2 in. (5,1 cm) above insulation is required.

Attic shields must meet specified clearance and be secured in place.

### Flat Ceiling Installation

- Remove one shield from box.

**NOTICE:** Cut previously installed batt insulation to make room for the attic insulation shield.

- Wrap shield around pipe if pipe is already installed in area to be insulated.
- Match the three holes in each side and fasten with three screws to form a tube.
- Bend three tabs on the bottom of the shield outward to allow attachment to the ceiling firestop.
- Bend the remaining bottom tabs inward 90° to maintain the air space between the pipe and the shield. Set the shield on the ceiling firestop and attach to the firestop.
- Bend all tabs inward 90° around the top of the shield. These tabs must be used to prevent blown insulation from getting between the shield and vent pipe, and to maintain air space clearance.

### Vaulted Ceiling Installation

- Remove one shield from box.

**NOTICE:** Cut previously installed batt insulation to make room for the attic insulation shield.

- Cut the attic insulation shield (if application is for vaulted ceiling) to fit your ceiling pitch. Snip cut edge to recreate 1 in. bend tabs all the way around the bottom.
- Wrap shield around pipe if pipe is already installed in area to be insulated.
- Match the three holes in each side and fasten with three screws to form a tube.
- Bend three tabs on the bottom of the shield outward to allow attachment to the ceiling firestop.
- Bend the remaining bottom tabs inward 90° to maintain the air space between the pipe and the shield. Set the shield on the ceiling firestop and attach to the firestop.
- Bend all tabs inward 90° around the top of the shield. These tabs must be used to prevent blown insulation from getting between the shield and vent pipe, and to maintain air space clearance.

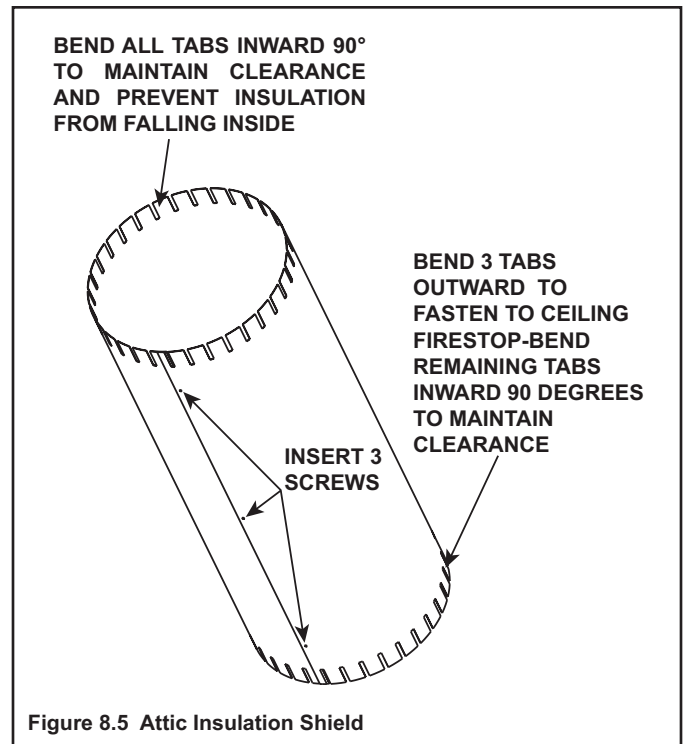

## E. Installing the Optional Heat-Zone-240V Kit

- Remove the knockout from the fireplace and discard it (see Figure 8.6).
- Center the duct collar around the exposed hole and attach it to the fireplace with 3 screws. Note: Do this BEFORE final positioning of fireplace.
- Determine the location for the air register/fan housing assembly.

Reference the Heat-Zone-240V Kit instructions for the remaining installation steps.

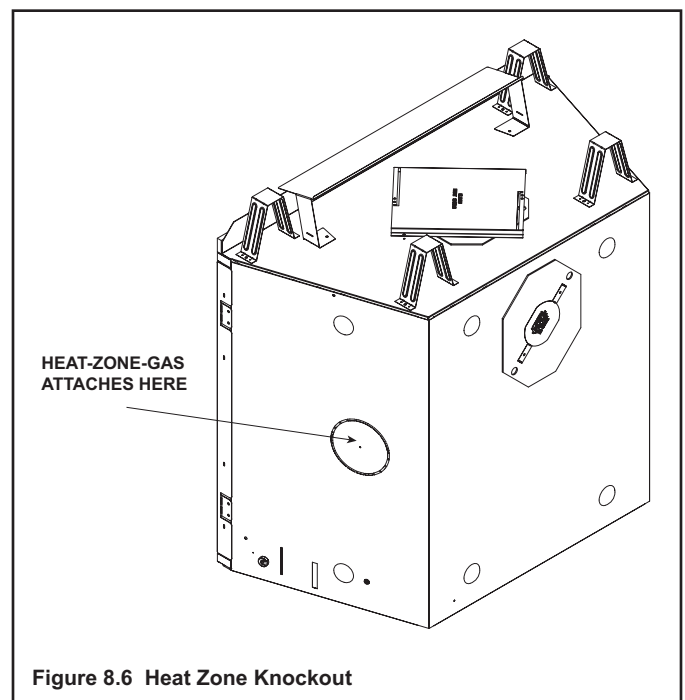

# 9 Appliance Preparation

## A. Top Vent

**CAUTION! Risk of Cuts, Abrasions or Flying Debris.** Wear protective gloves and safety glasses during installation. Sheet metal edges are sharp.

**NOTICE:** Once appliance is set up for top or rear venting, it CANNOT be changed at a later time.

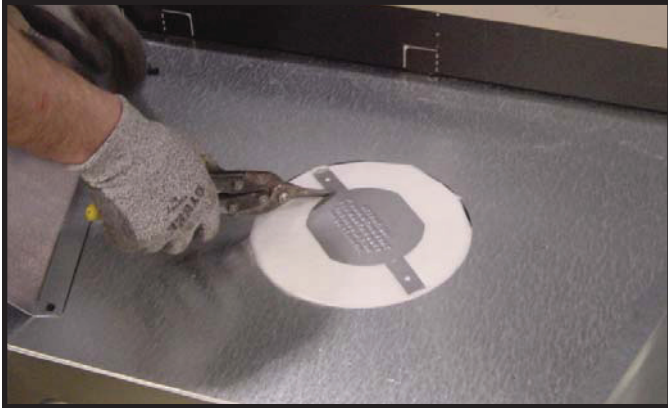

**Figure 9.1** Cut the seal cap strap across the rectangles next to the disk. For rear vent, skip this step.



**Figure 9.2** Remove the white gasket material covering the seal cap.

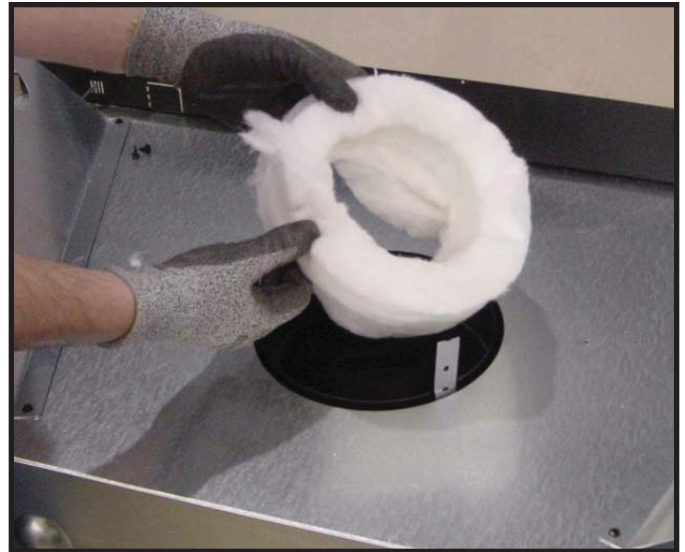

**Figure 9.3** Remove the seal cap.

**NOTICE:** Once the seal cap has been removed it CANNOT be reattached.



**Figure 9.4** Remove the insulation basket and white insulation from the center vent pipe.



**Figure 9.5** Remove the insulation from the outer vent pipe. For rear venting there is no insulation in the outer vent pipe.

### **WARNING**



Fire Risk  
Explosion Risk

The rear flue collar seal cap must remain attached to the rear flue collars if the flue system is attached to the top starting collars.





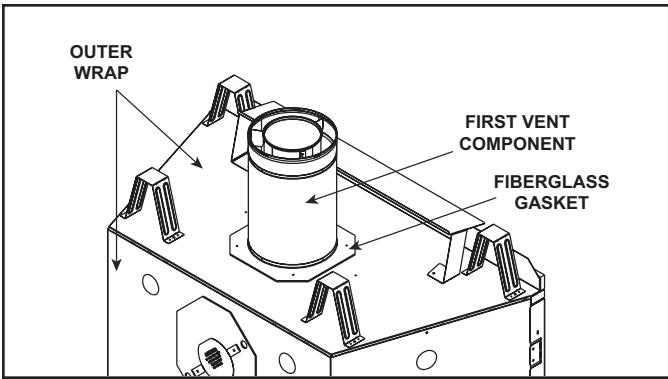

**Figure 9.6** To attach the first section of vent pipe, make sure to use the fiberglass gasket in the manual bag to seal between the first vent component and the outer fireplace wrap. Use 2 self tapping screws to secure the gasket to the outer wrap.

Secure the first section of venting to the fireplace by screwing through the two straps left over from cutting the seal cap strap in step 2.

## B. Rear Vent

**CAUTION! Risk of Cuts, Abrasions or Flying Debris.** Wear protective gloves and safety glasses during installation. Sheet metal edges are sharp.

**NOTICE:** Once appliance is set up for top or rear venting, it CANNOT be changed at a later time.

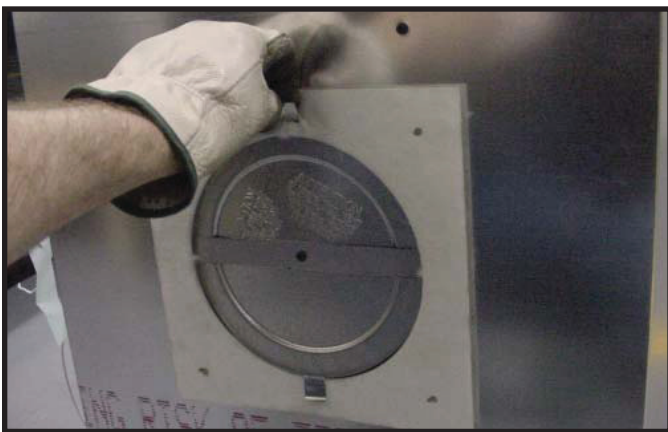

**Figure 9.7** Fold the tabs toward the center of the seal cap (90°) and remove the insulation gasket.



**Figure 9.8** Cut the metal retaining band and fold the sides out.



**Figure 9.9** Fold the center parts of the retaining band out and use to remove the seal cap.

**NOTICE:** Once the seal cap has been removed it CANNOT be reattached.



**Figure 9.10** Discard the vent cap, remove and discard the insulation basket.

<b>⚠ WARNING</b>	
	<p>Fire Risk Explosion Risk</p>
<p>The rear flue collar seal cap must remain attached to the rear flue collars if the flue system is attached to the top starting collars.</p>	

**WARNING! Risk of Fire!** The top heat shield (inside the firebox) must remain attached if the flue system is attached to the rear starting collars.

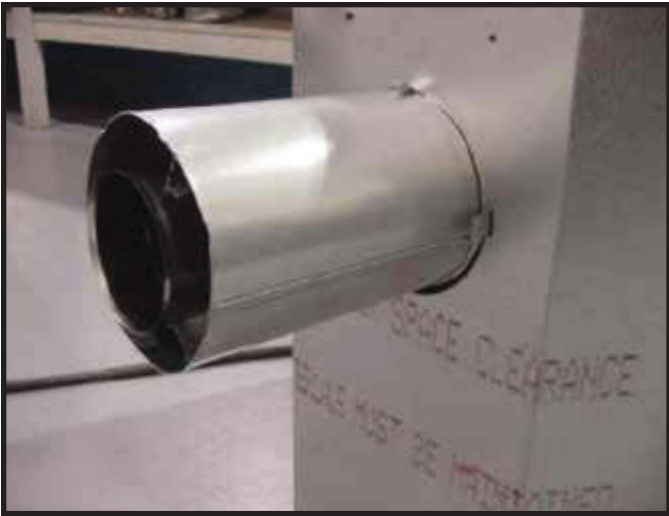

**Figure 9.11** Attach the first vent section (it will snap into place). Slide the insulation gasket onto the vent section, up against the appliance and over the tabs.

### C. Installing the Non-combustible Board

The factory supplied non-combustible board must be used. See Figure 9.12.

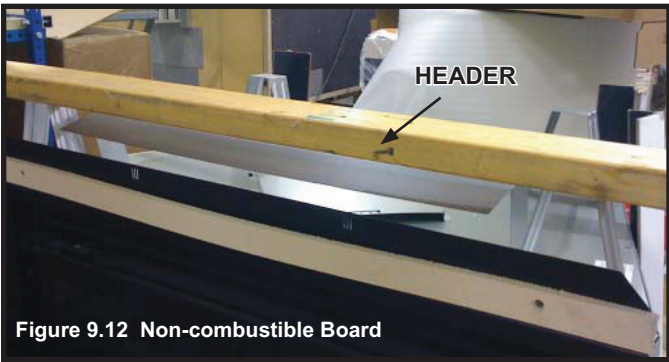

**Figure 9.12** Non-combustible Board

### D. Securing and Leveling the Appliance

**WARNING! Risk of Fire!** Prevent contact with:

- Sagging or loose insulation
- Insulation backing or plastic
- Framing and other combustible materials

Block openings into the chase to prevent entry of blown-in insulation. Make sure insulation and other materials are secured.

**DO NOT** notch the framing around the appliance standoffs.

Failure to maintain air space clearance may cause overheating and fire.

The diagram shows how to properly position and secure the appliance (see Figure 9.14). Nailing tabs are provided to secure the appliance to the framing members.

- Bend out nailing tabs on each side.
- Place the appliance into position.

- Keep nailing tabs flush with the framing.
- Level the appliance from side to side and front to back.
- “Square” the unit by securing diagonal dimensions to within 1/4 inch of each other. See Figure 9.13.
- Shim the appliance as necessary. It is acceptable to use wood shims underneath the appliance.
- Secure the appliance to the framing by using nails or screws through the nailing tabs.
- Secure the appliance to the floor by inserting two screws through the pilot holes at the bottom of the appliance.

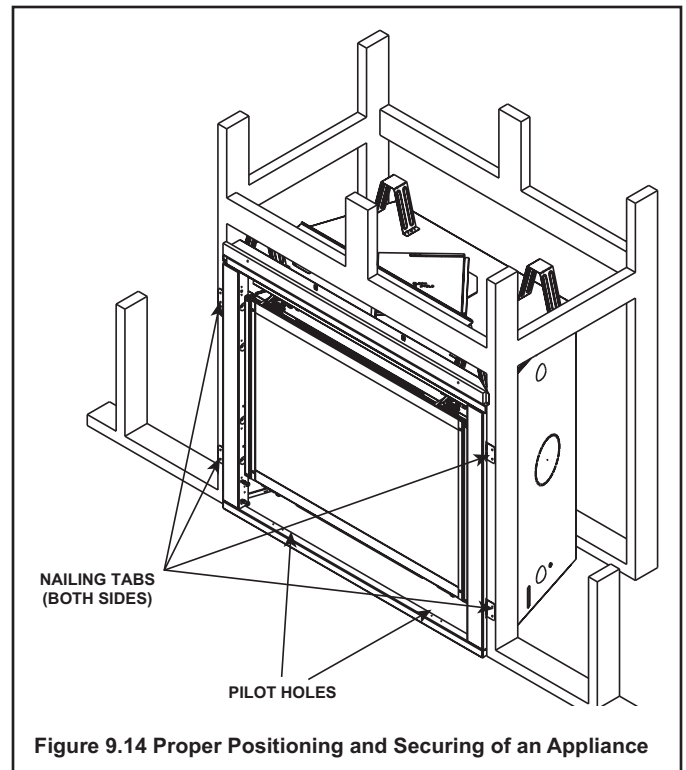
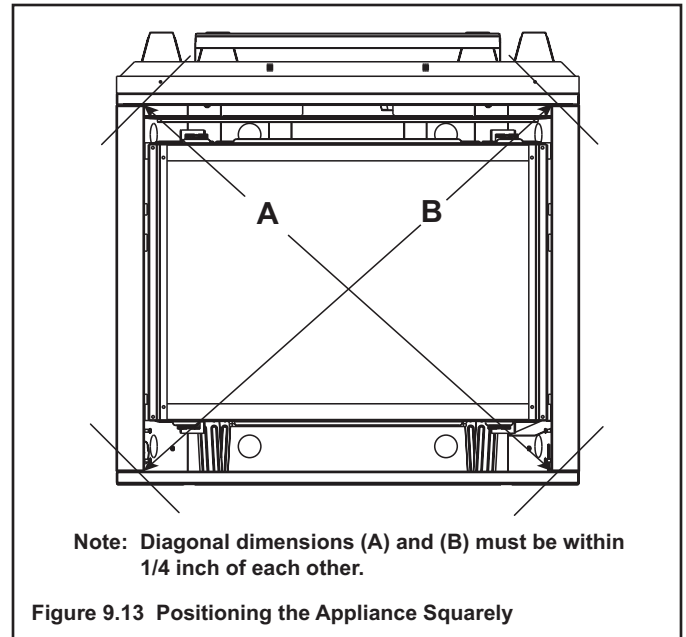



## E. Covers Removal For Servicing

### Control Compartment Access Door

- Lift the lower door up and out to access the gas controls.

### Trim Door and Glass Door

- Lift the front trim door up and out away from the appliance side surrounds. Replace the door when servicing is complete.
- Noting carefully how the brackets fit on the glass, release the two spring latches at the top and two at the bottom of the glass door. Carefully lift the glass up and out away from the appliance. See Figure 9.15.

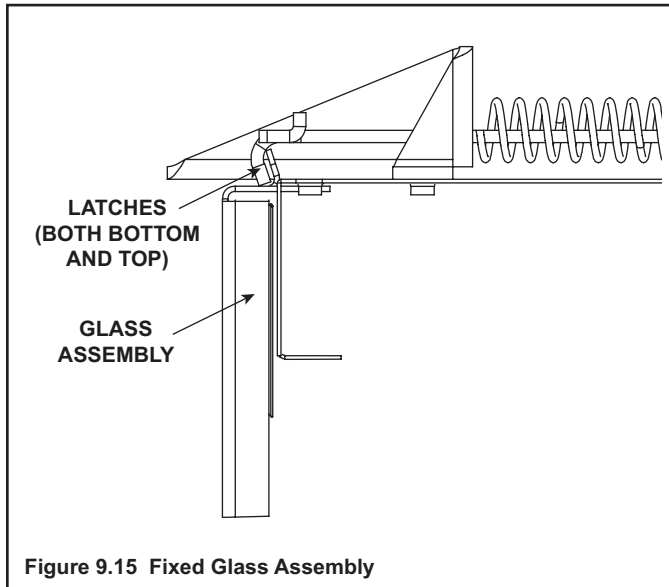

## F. Components Removal For Service

- Release the screws at the base of the log grate and carefully lift up and remove the logs and log grate.
- Remove the base pan.
- Unscrew the brackets at both ends of the burner and the top two screws locating the pilot bracket (see Figure 9.16). Slide the burner away from the burner orifice.

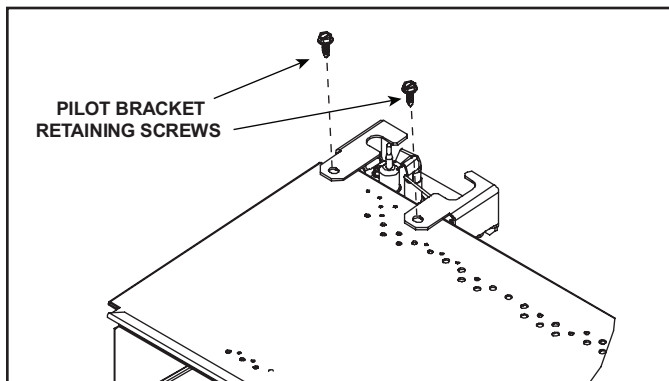

**Figure 9.16**

**NOTICE:** All screws which were removed must be replaced.

## Pilot Assembly/Ignition System

- Remove the log set, log grate and burner assembly.
- Disconnect the gas supply tube from the outlet side of valve.
- Disconnect the orange ignitor wire (I) and white sensor wire (S) from module.
- Unscrew the pilot assembly bracket and remove, the pilot assembly along with silicone sealant grommet.

## G. Parts Replacement

### Fan

- Unplug the fan from the AUX300CE and slide the fan out the front of the lower controls compartment.
- Fan can be operated at 3 speed levels using RC300AU remote and AUX300CE. Refer to RC300AU section.
- The fan will automatically turn on after 7 minutes and will stop 12 minutes after unit has been turned off.

### Glass Panel

- To replace the glass door, place the bottom edge into the lower holders, push glass against unit and secure the two spring latches at the top and bottom.

## H. Adjustments And Replacement Parts

Adjustments and replacement parts for this appliance should only be done by a qualified service person. A wiring diagram for the appliance is shown in Section 12. A service parts list is shown in Section 16 of this manual.

## I. Install Trim and/or Surround

- Install optional trim kits and/or surrounds using the instructions included with the accessory.
- Use non-combustible materials to cover the gap between the sheet rock and the appliance (when applicable to the model).

## J. Air Shutter Setting

	Natural Gas	Propane	Butane
<b>6TRSI-AUD</b>	12.5 mm	N/A	N/A
<b>6TRSILP-AUD</b>	N/A	Full Open	Full Open

# 10 Installing Vent Pipe

## A. Assemble Vent Sections

### Attach Vent to the Firebox Assembly

**Note:** The end of the pipe sections with the lanced tabs will face toward the appliance.

Attach the first pipe section to the starting collar:

- Lanced pipe end to the starting collar
- Inner pipe over inner collar
- Push the pipe section until all lanced tabs snap in place
- Lightly tug on pipe to confirm it has locked.

### Commercial, Multi-family (Multi-level exceeding two stories), or High-Rise Applications

All outer pipe joints must be sealed with high temperature silicone, including the slip section that connects directly to the horizontal termination cap.

- Apply a bead of silicone sealant inside the female outer pipe joint prior to joining sections. See Figure 10.1
- Only outer pipes need to be sealed. All unit collar, pipe, slip section, elbow and cap outer flues shall be sealed in this manner, unless otherwise stated.

**WARNING! Risk of Fire or Explosion! DO NOT break silicone seals on slip sections. Use care when removing termination cap from slip pipe. If slip section seals are broken during removal of the termination cap, vent may leak.**

### Assemble Pipe Sections

Per Figure 10.2:

- Start the inner pipe on the lanced end of section A into the flared end of section B.
- Start the outer pipe of section A over the outer pipe of section B.
- Once both vents sections are started, push firmly until all lanced tabs lock into place.
- Lightly tug on the pipe to confirm the tabs have locked.

It is acceptable to use screws no longer than 1/2 in. (13 mm) to hold outer pipe sections together. If predrilling holes, **DO NOT** penetrate inner pipe.

For 90° and 45° elbows that are changing the vent direction from horizontal to vertical, one screw minimum should be put in the outer flue at the horizontal elbow joint to prevent the elbow from rotating. Use screws no longer than 1/2 in. (13 mm). If predrilling screw holes, **DO NOT** penetrate inner pipe.



Figure 10.1 High Temperature Silicone Sealant or High Temperature Foil Tape

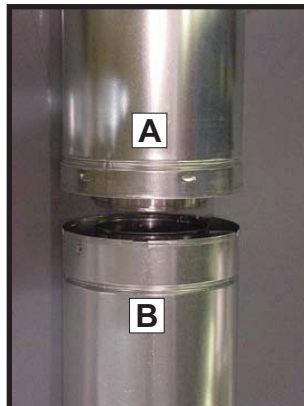

Figure 10.2

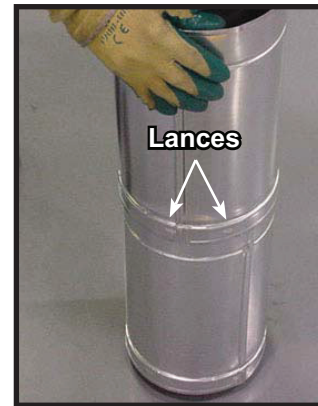

Figure 10.3

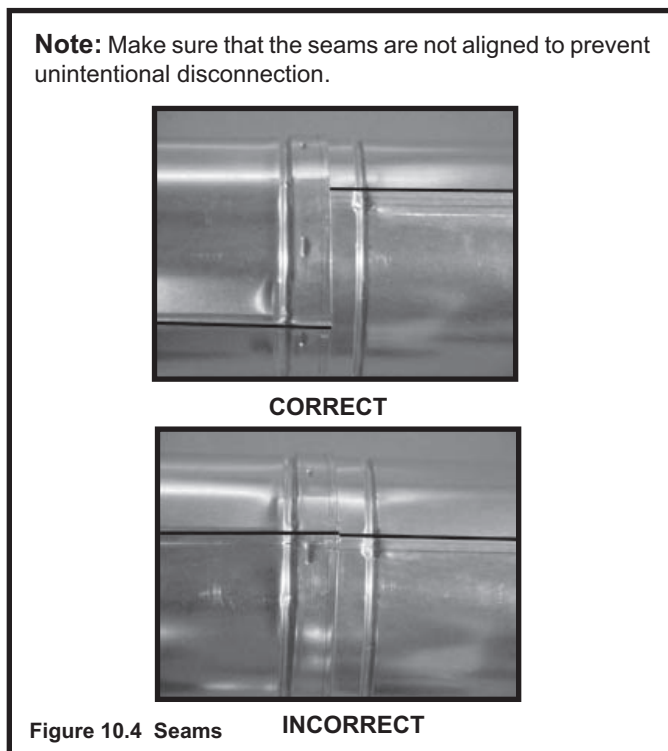

Figure 10.4 Seams

## B. Assemble Slip Sections

- Slide the inner flue of the slip section into the inner flue of the pipe section and the outer flue of the slip section over the outer flue of the pipe section. See Figure 10.6.
- Slide together to the desired length.

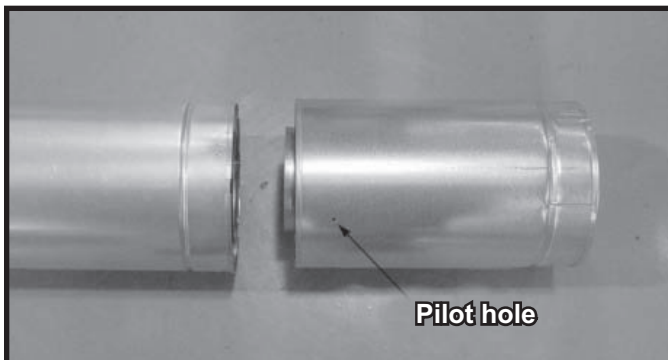

Figure 10.6 Slip Section Pilot Holes

- Maintain a 1-1/2 in. (38 mm) overlap between the slip section and the pipe section.
- Secure the pipe and slip section with two screws no longer than 1/2 in. (13 mm), using the pilot holes in the slip section. See Figure 10.7.

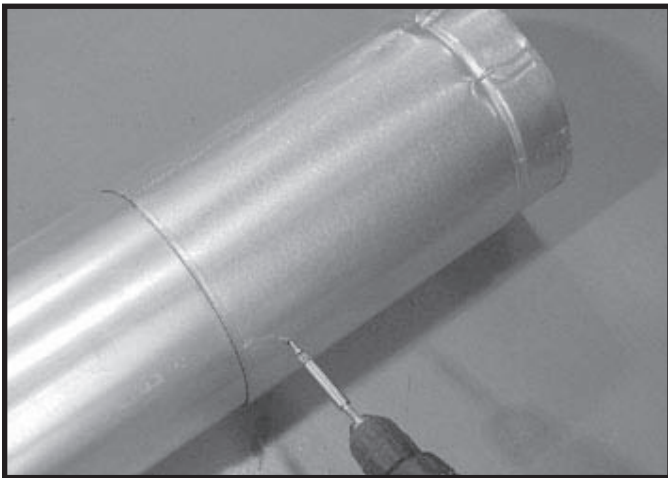

Figure 10.7 Screws into Slip Section

- Continue adding pipe as necessary following instructions in “Assembling Pipe Sections.”

**NOTICE:** If slip section is too long, the inner and outer flues of the slip section can be cut to the desired length.

**NOTICE:** When installing a vent system with an HRC termination cap, all pipe system joints shall be sealed using a high temperature silicone sealant.

- Apply a bead of silicone sealant inside the female outer pipe joint prior to joining sections.
- Only outer pipes are sealed, sealing the inner flue is not required.
- All unit collar, pipe, slip section, elbow and cap outer flues shall be sealed.

## C. Secure the Vent Sections

- Vertical runs of DVP pipe must be supported every 8 ft. (2.44 m) after the 25 ft. (7.62 m) maximum unsupported rise.
- Horizontal sections must be supported every 5 feet (1.52 m).
- Vent supports or plumbers strap (spaced 120° apart) may be used to support vent sections. See Figures 10.8 and 10.9.
- Wall shield firestops may be used to provide horizontal support vent sections.

**WARNING! Risk of Fire, Explosion or Asphyxiation!** Improper support may allow vent to sag and separate. Use vent run supports and connect vent sections per installation instructions. **DO NOT** allow vent to sag below connection point to appliance.

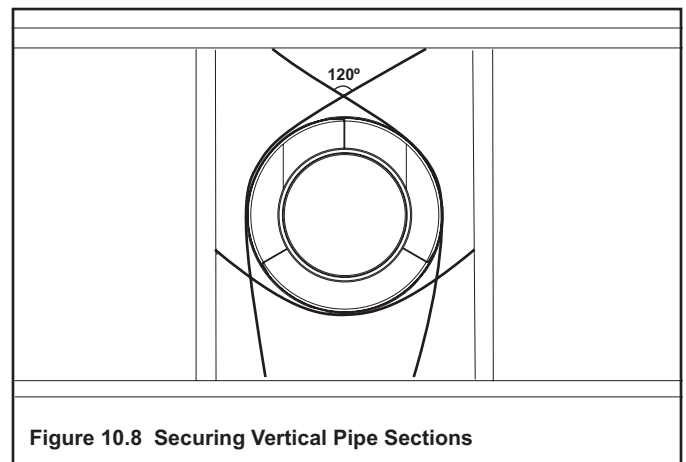

Figure 10.8 Securing Vertical Pipe Sections

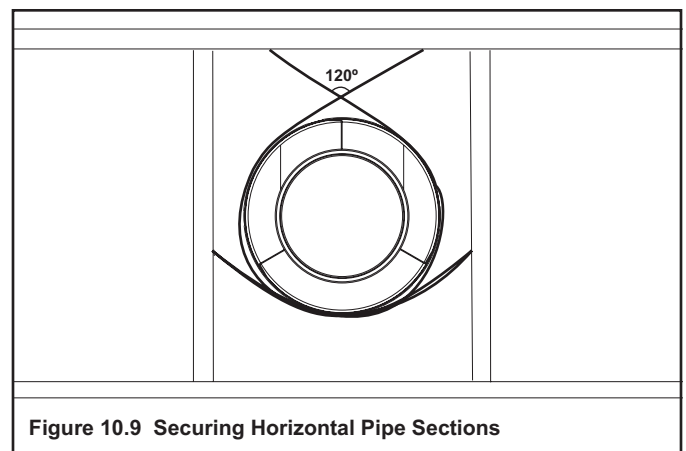

Figure 10.9 Securing Horizontal Pipe Sections

## D. Disassemble Vent Sections

- Rotate either section (see Figure 10.10) so the seams on both pipe sections are aligned as shown in Figure 10.11.
- Pull carefully to separate the pieces of pipe.

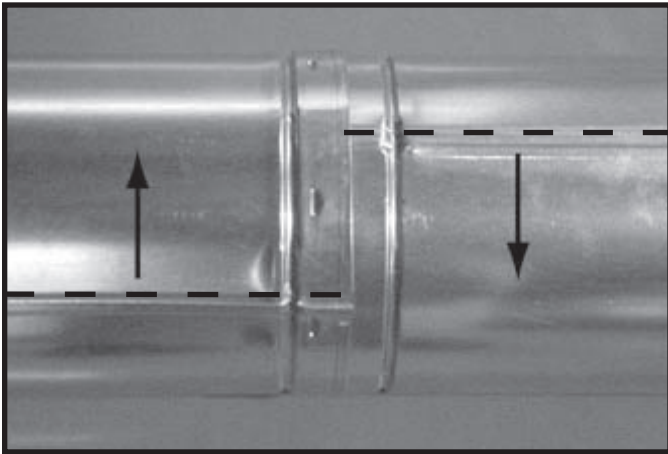

Figure 10.10 Rotate Seams for Disassembly

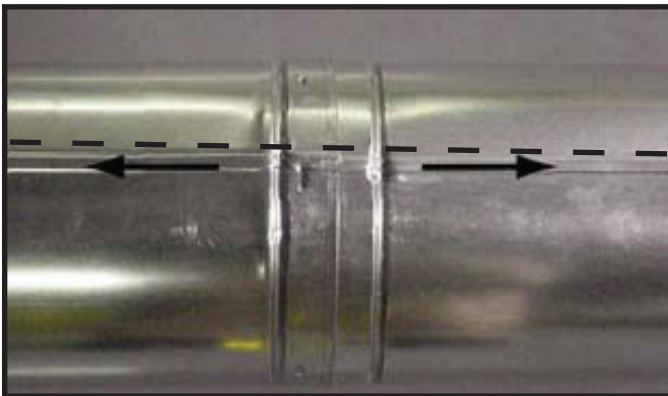

Figure 10.11 Align and Disassemble Vent Sections

## E. Install Support Brackets

**For Horizontal Runs** - The flue system must be supported every five (5) feet (1.52 m) of horizontal run by a horizontal pipe support. To install support brackets for horizontal runs:

- Place the pipe supports around the flue pipe.
- Nail the pipe supports to the framing members.

**For Vertical Runs** - The flue system must be supported every eight feet (2.44 m) above the heater flue outlet by wall brackets (see Figure 10.12). To install support brackets for vertical runs:

- Attach wall brackets to the flue pipe and secure the wall bracket to the framing members with nails or screws.

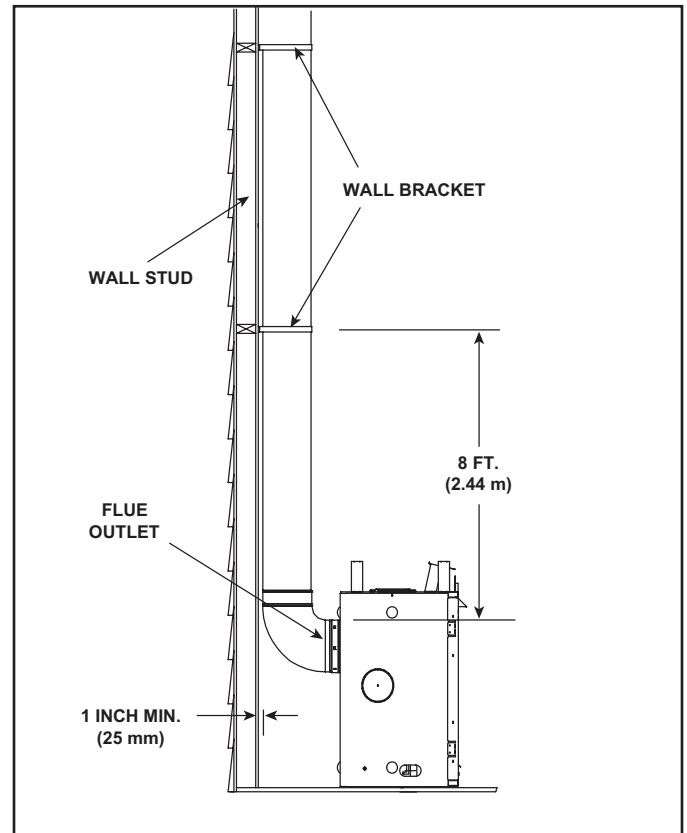

Figure 10.12 Installing Support Brackets

## F. Install Firestops

**For Horizontal Runs** - Firestops are **REQUIRED** on both sides of a combustible wall through which the flue passes. See Figure 10.13.

To install firestops (heat shield) for horizontal runs that pass through either interior or exterior walls:

- Cut a 10 inch by 12 inch (254 mm X 305 mm) hole through the wall.
- Position the firestops on both sides of the hole previously cut and secure the firestops with nails or screws.
- The pipe opening of the firestops **MUST BE** placed towards the bottom of the firestop.
- Continue the flue run through the firestop.

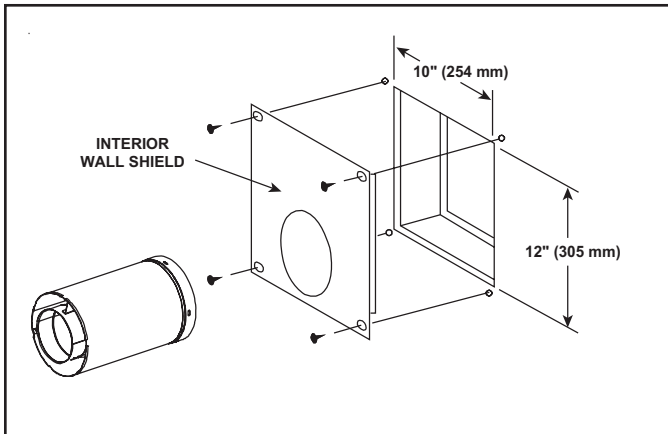

Figure 10.13 Flue Pipe & Firestop

**For Vertical Runs** - One firestop is **REQUIRED** at the hole in each ceiling through which the flue passes.

To install firestops for vertical runs that pass through ceilings:

- Position a plumb bob directly over the center of the vertical flue component.
- Mark the ceiling to establish the centerpoint of the flue.
- Drill a hole or drive a nail through this center point.
- Check the floor above for any obstructions, such as wiring or plumbing runs.
- Reposition the heater and flue system, if necessary, to accommodate the ceiling joists and/or obstructions.
- Cut a 10 in. x 10 in. (254 mm X 254 mm) hole through the ceiling, using the firestop pipe opening as a guide.
- Frame the hole with framing lumber the same size as the ceiling joists.

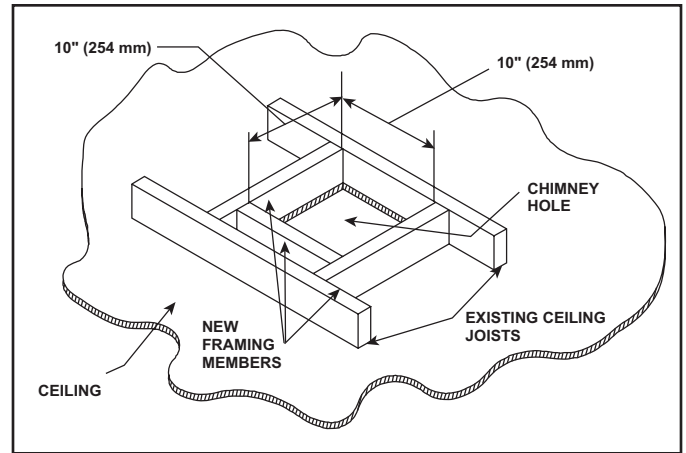

Figure 10.14 Hole and New Framing Members

If the area above the ceiling is **NOT** an attic, position and secure the ceiling firestop on the ceiling side of the previously cut and framed hole.

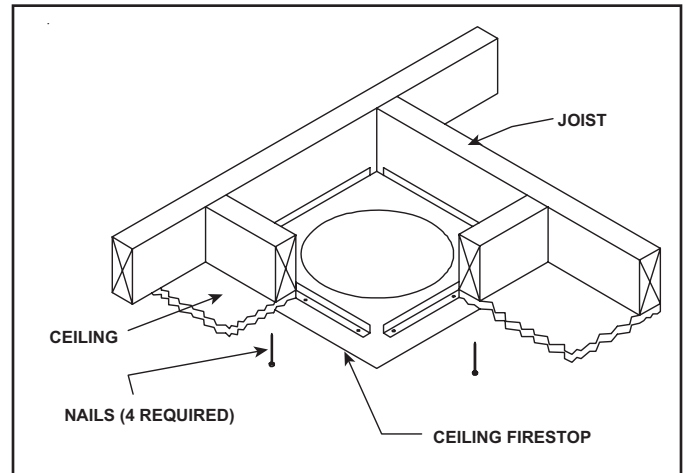

Figure 10.15 Ceiling Firestop (Ceiling Side)

If the area above the ceiling **IS** an attic, position and secure the firestop on top of the previously framed hole.

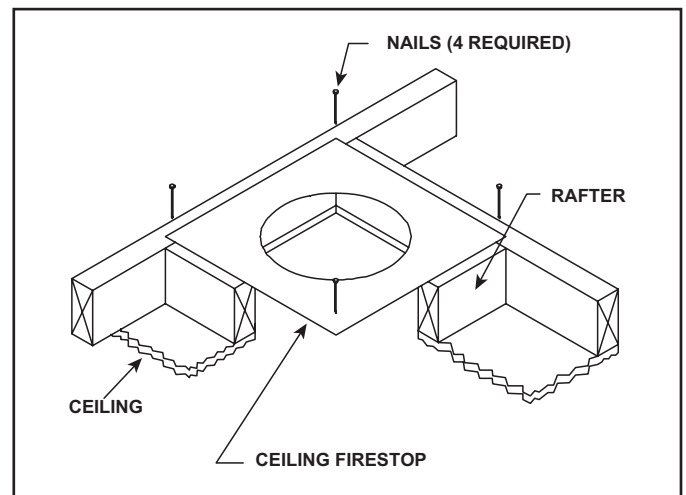

Figure 10.16 Attic Firestop



## G. Flue Termination

**For Horizontal Terminations** - To attach and secure the termination to the last section of horizontal flue:

- The rear flue heat shield **MUST** be placed one inch above the top of the flue between the wall shield and the base of the termination cap.
- One section of the heat shield is attached to the wall shield. The other is attached to the termination cap in the same manner.
- The heat shield sections will overlap to match the wall thickness (depth).
- If the wall thickness does not allow the required 1-1/2 inch heat shield overlap, an extended heat shield must be used. The extended heat shield will need to be cut to the thickness of the wall and be attached to the wall shield.
- The small leg in the shield rests on top of the flue to properly space it from the pipe section (see Figure 10.17).

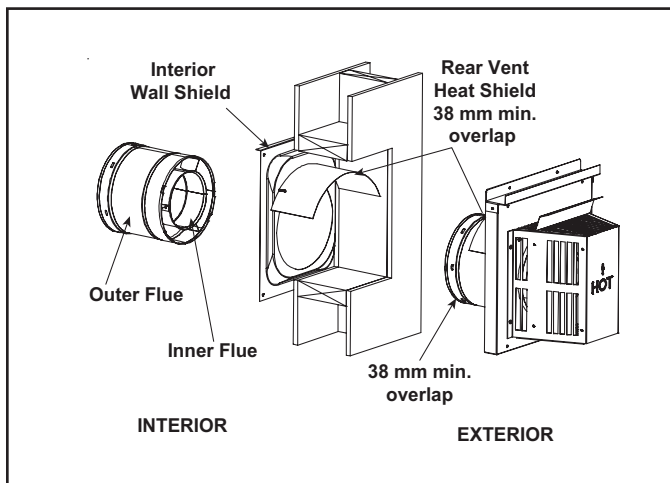

Figure 10.17 Flueing through the Wall

- The termination kit should pass through the wall firestops from the exterior of the building.

- Adjust the termination cap to its final exterior position on the building and interlock the flue sections.

**WARNING! Risk of fire!** The termination cap must be positioned so that the arrow is pointing up.

- Use a high-temperature sealant gasket to seal between the pipe and exterior firestop.

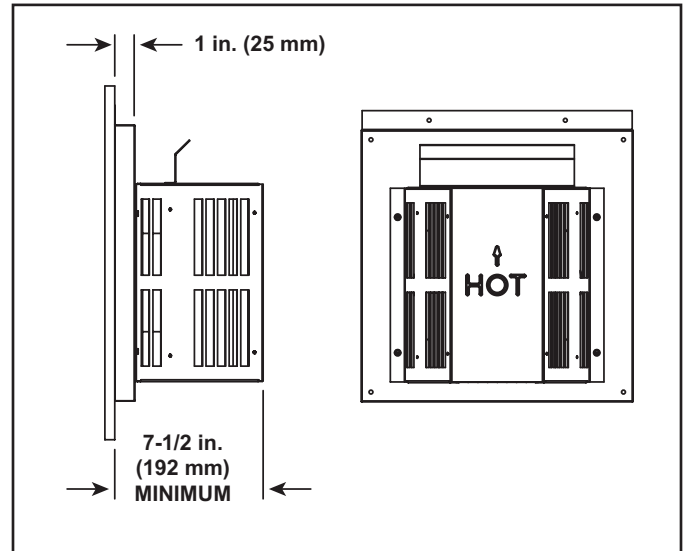

Figure 10.18 Termination Cap

**Cap Specification Chart**  
(depth without using additional pipe sections)

6TRSI-AUD 6TRSILP-AUD	DVP-TRAP2 Rear Vent <u>Depth</u>
	5-1/2 in. (152 mm) to 9-1/2 in. (241 mm)

DVP-TRAP2 can adjust 4 in. 102 mm (5-3/8 to 9-3/8) (132 mm to 238 mm)



## H. Heat Shield Requirements for Horizontal Termination

**WARNING! Risk of Fire!** To prevent overheating and fire, heat shields must extend through the entire wall thickness.

- **DO NOT** remove the heat shields attached to the wall shield firestop and the horizontal termination cap (shown in Figure 10.23).
- Heat shields must overlap 1-1/2 in. (38 mm) minimum.

There are two sections of the heat shield. One section is factory-attached to the wall shield firestop. The other section is factory-attached to the cap. See Figure 10.23.

If the wall thickness does not allow the required 1-1/2 in. (38 mm) heat shield overlap when installed, an extended heat shield must be used.

- If the wall thickness is less than 4 in./102 mm DVP, the heat shields on the cap and wall shield firestop must be trimmed. A minimum 1-1/2 in. (38 mm) overlap **MUST** be maintained.
- Use an extended heat shield if the finished wall thickness is greater than 7-1/4 in. (184 mm).
- The extended heat shield may need to be cut to length maintaining sufficient length for a 1-1/2 in. (38 mm) overlap between heat shields.
- Attach the extended heat shield to either of the existing heat shields using the screws supplied with the extended heat shield. Refer to vent components diagrams in the back of this manual.
- Rest the small leg on the extended heat shield on top of the pipe section to properly space it from the pipe section.

**Important Notice:** Heat shields may not be field constructed.

## I. Install Metal Roof Flashing

- See minimum vent heights for various pitched roofs (Figure 10.19) to determine the length of pipe to extend through the roof.
- Slide the roof flashing over the pipe sections extending through the roof as shown in Figure 10.20.

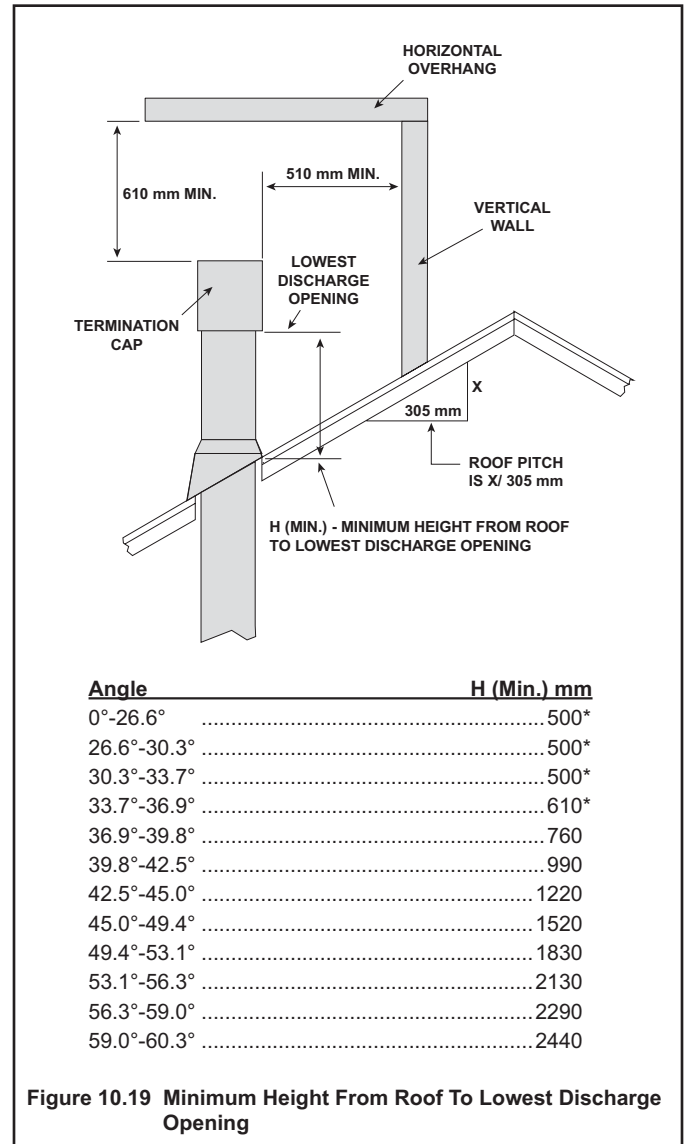

**NOTICE:** Failure to properly caulk the roof flashing could cause water entry.

- Caulk the gap between the roof flashing and the outside diameter of the pipe.
- Caulk the perimeter of the flashing where it contacts the roof surface. See Figure 10.20.

**CAUTION! Risk of Fire!** Follow the requirements of the Australian gas installation code for minimum height requirements above the roof.

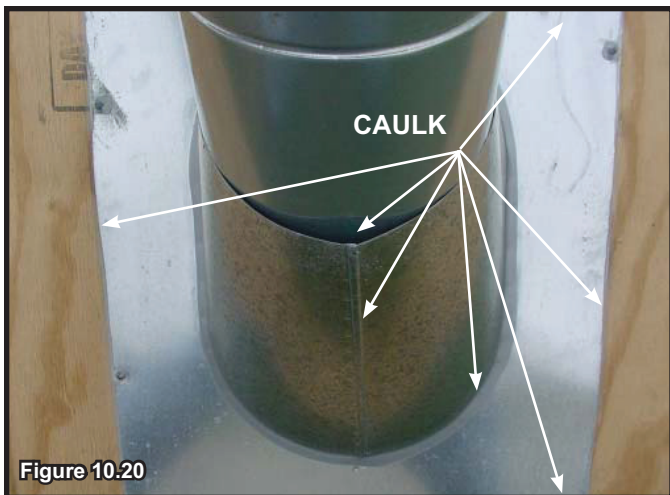

Figure 10.20

## J. Assemble and Install Storm Collar

**CAUTION! Risk of Cuts, Abrasions or Flying Debris.** Wear protective gloves and safety glasses during installation. Sheet metal edges are sharp.

- Connect both halves of the storm collar with two screws (see Figure 10.21).
- Wrap the storm collar around the exposed pipe section closest to the roof and align brackets. Insert a bolt (provided) through the brackets and tighten the nut to complete the storm collar assembly. Make sure the collar is tight against the pipe section.
- Slide the assembled storm collar down the pipe section until it rests on the roof flashing (see Figure 10.22).
- Caulk around the top of the storm collar (see Figure 10.23).

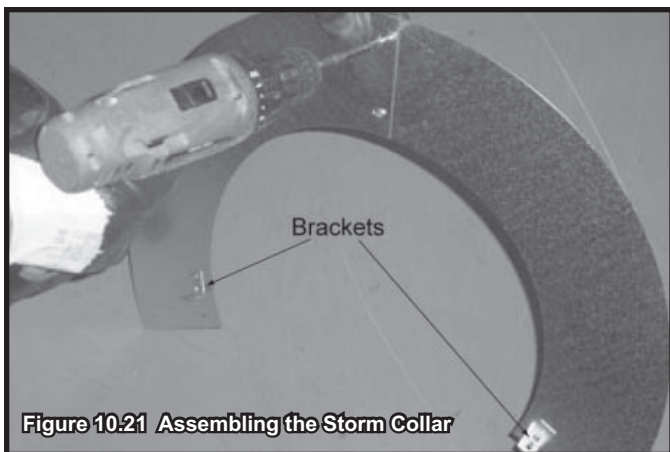

Figure 10.21 Assembling the Storm Collar

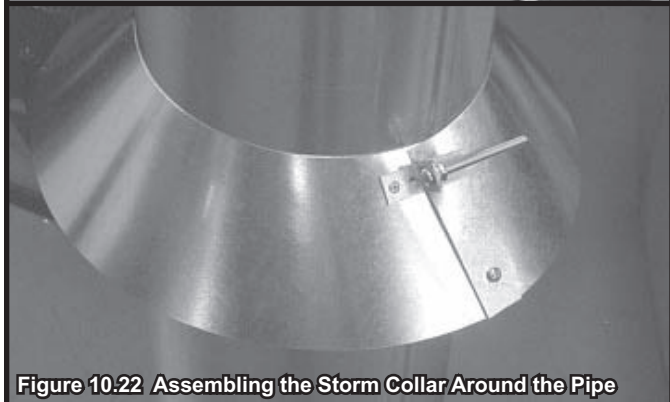

Figure 10.22 Assembling the Storm Collar Around the Pipe

## K. Install Vertical Termination Cap

- Locate and mark the flue center point on the underside of the roof, and drive a nail through the center point.
- Make the outline of the roof hole around the center point nail.
- The size of the roof hole framing dimensions depend on the pitch of the roof. There **MUST BE** a 1 inch (25 mm) clearance from the vertical flue pipe to combustible materials.
- Mark the roof hole accordingly.
- Cover the opening of the installed flue pipes.
- Cut and frame the roof hole.
- Use framing lumber the same size as the roof rafters and install the frame securely. Flashing anchored to the frame must withstand heavy winds.
- Continue to install concentric flue sections up through the roof hole and up past the roof line until you reach the appropriate distance above the roof.
- Attach the vertical termination cap by sliding the inner collar of the cap into the inner flue of the pipe section while placing the outer collar of the cap over the outer flue of the pipe section.
- Secure the cap by driving three self-tapping screws (supplied) through the pilot holes in the outer collar of the cap into the outer flue of the pipe (see Figure 10.23).



Figure 10.23

# 11 Gas Information

## A. Gas Pressure Requirements



**WARNING! Risk of Explosion!** An in-line regulator **MUST** be installed if the gas pressure exceeds 3.7 kPa. Failure to install a regulator could damage valve.

Pressure requirements for 6TRSI-AUD and 6TRSILP-AUD fireplaces are shown in the table below.

Two taps are provided on the right hand side of the gas control for a test gauge connection to measure the inlet and outlet pressures.

The fireplace and its individual shut-off valve must be disconnected from the gas supply piping system during any pressure testing of the system at test pressures in excess of 6 kPa.

If the fireplace must be isolated from the gas supply piping system by closing an individual shut-off valve, it must be of the handle-less type.

 <b>WARNING</b>	
  	<p>Fire Risk Explosion Risk High pressure will damage valve.</p> <ul style="list-style-type: none"> <li>• Disconnect gas supply piping <b>BEFORE</b> pressure testing gas line at test pressures above 6 kPa.</li> <li>• Close the manual shutoff valve <b>BEFORE</b> pressure testing gas line at test pressures equal to or less than 6 kPa.</li> </ul>

## B. Gas Connection



**Note:** Have the gas supply line installed in accordance with local building codes by a qualified installer approved and/or licensed as required by the locality.

**Note:** Before the first firing of the appliance, the gas supply line should be purged of any trapped air.

**Note:** Consult local building regulations to properly size the gas supply line leading to the (Rp 1/2 in.) hook-up at the unit.

Incoming gas line should be piped into the valve compartment and connected to the ISO 7-Rp 1/2 (BSP Rp 1/2) threaded gas inlet connection on the manual shutoff valve.

Leak test all gas line points and the gas control valve prior to and after starting the gas appliance.

 <b>WARNING</b>	
  	<p><b>CHECK FOR GAS LEAKS</b> Explosion Risk Fire Risk Asphyxiation Risk</p> <ul style="list-style-type: none"> <li>• Check all fittings and connections.</li> <li>• Do not use open flame.</li> <li>• After the gas line installation is complete, all connections must be tightened and checked for leaks with a commercially-available, non-corrosive leak check solution. Be sure to rinse off all leak check solution following testing.</li> </ul> <p>Fittings and connections may have loosened during shipping and handling.</p>

	Natural Gas	Propane
Inlet Pressure	1.13 kPa	2.75 kPa
Outlet Gas Pressure	0.80 kPa	2.40 kPa
Maximum Gas Consumption	36 MJ/h	34.0 MJ/h
Burner Injector	DMS 33 (2.87 mm)	DMS 51 (1.70 mm)
Pilot Injector	.0121	0.0181

An in-line regulator **MUST** be installed if the gas pressure exceeds 3.7 kPa. Failure to install a regulator could damage valve.

The gas is introduced to the appliance on the left hand side. See Figure 11.1. Section 16 also shows location of gas line in appliance.

After the gas pipe installation is complete, check carefully all gas connections for leaks with a commercially-available, noncorrosive leak check solution. Be sure to rinse off all leak check solution following testing. **DO NOT USE AN OPEN FLAME.**

**NOTICE:** the gas supply line should be purged of any trapped air prior to the first firing of the unit.

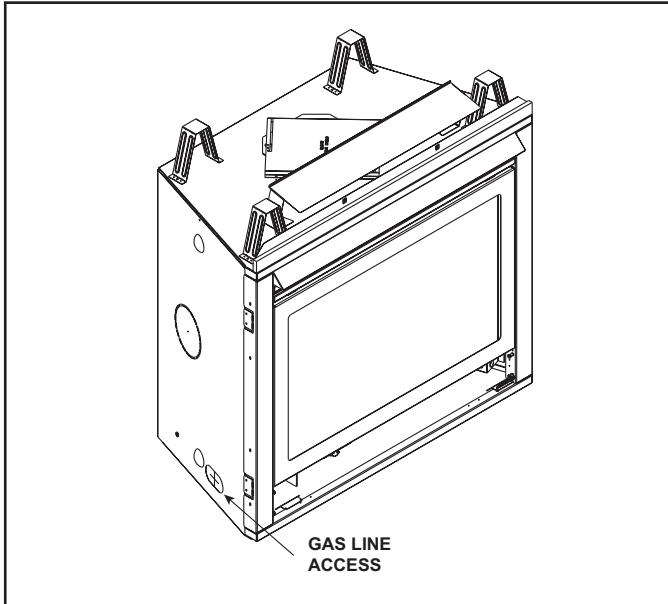

Figure 11.1

- Gas line may be run through knockout(s) provided.
- The gap between supply piping and gas access hole may be caulked with high temperature caulk or stuffed with non-combustible, unfaced insulation to prevent cold air infiltration.
- Ensure that gas line does not come in contact with outer wrap of the appliance. Follow local codes. Reference AS5601 Gas Installation Standard
- Pipe incoming gas line into valve compartment.
- Connect incoming gas line to the connection on manual shutoff valve.

**WARNING! Risk of Fire or Explosion!** Support control when attaching pipe to prevent bending gas line.

- A small amount of air will be in the gas supply lines.

**WARNING! Risk of Fire or Explosion!** Gas build-up during line purge could ignite.

- Purge should be performed by qualified service technician.
- Ensure adequate ventilation.
- Ensure there are no ignition sources such as sparks or open flames.

Light the appliance. It will take a short time for air to purge from lines. When purging is complete the appliance will light and operate normally.

**WARNING! Risk of Fire, Explosion or Asphyxiation!** Check all fittings and connections with a non-corrosive commercially available leak-check solution. **DO NOT** use open flame. Fittings and connections could have loosened during shipping and handling.

**WARNING! Risk of Fire! DO NOT** change valve settings. This valve has been preset at the factory.

# 12 Electrical Information

## A. Wiring Requirements

**NOTICE:** This appliance must be installed by a qualified electrician in accordance with the relevant national and local regulations.

- Wire the appliance junction box to 220-240 VAC. This is required for proper operation of the appliance.

**WARNING! Risk of Shock or Explosion! DO NOT** wire 220/240 VAC to the valve or to the appliance wall switch. Incorrect wiring will damage controls.

**NOTICE:** The mains supply to the appliance must have isolation of a minimum 3 mm contact separation in both poles.

**WARNING! Risk of Injury!** The gas supply shall be shut off prior to disconnecting the electrical power and removing batteries (if installed) before proceeding with any maintenance to the appliance.

## B. IntelliFire Ignition System Wiring

- Wire the appliance junction box to 220-240 VAC for proper operation of the appliance.

**WARNING! Risk of Shock or Explosion! DO NOT** wire IPI controlled appliance junction box to a switched circuit. Incorrect wiring will override IPI safety lockout.

- Refer to Figure 12.1, IntelliFire Pilot Ignition (IPI) Wiring Diagram.
- This appliance is equipped with an IntelliFire control valve which operates on a 6 volt system.

- For units installed in Australia, the residence's 220/240 wall outlet to which this appliance's power cord is connected, must be wired to an in-line on/off switch. This is required for servicing and/or resetting the control module in the event of a control module LOCK-OUT.
- Plug the 6-volt AC power supply into the appliance junction box to supply power to the unit.

## C. Optional Accessories Requirements

- This appliance may be used with a wall switch, wall mounted thermostat and/or a remote control.

Wiring for optional Hearth & Home Technologies approved accessories should be done now to avoid reconstruction. Follow instructions that come with those accessories.

### Optional Remote Control Receiver Location

The control module and remote control receiver can be accessed through the air space below the firebox front and the lower access door.

The IPI control module and the remote control receiver are placed on the firebox bottom.

**WARNING! Risk of Shock!** Label all wires prior to disconnection when servicing controls. Wiring errors can cause improper and dangerous operation. Verify proper operation after servicing.

**WARNING! Risk of Shock!** Replace damaged wire with type 105° C rated wire. Wire must have high temperature insulation.

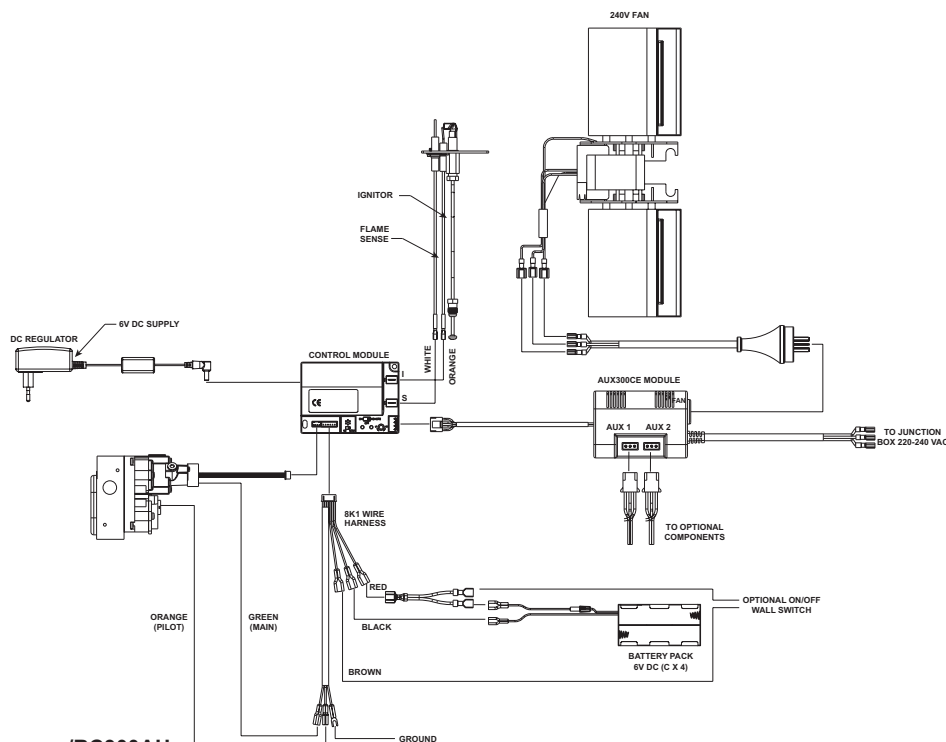
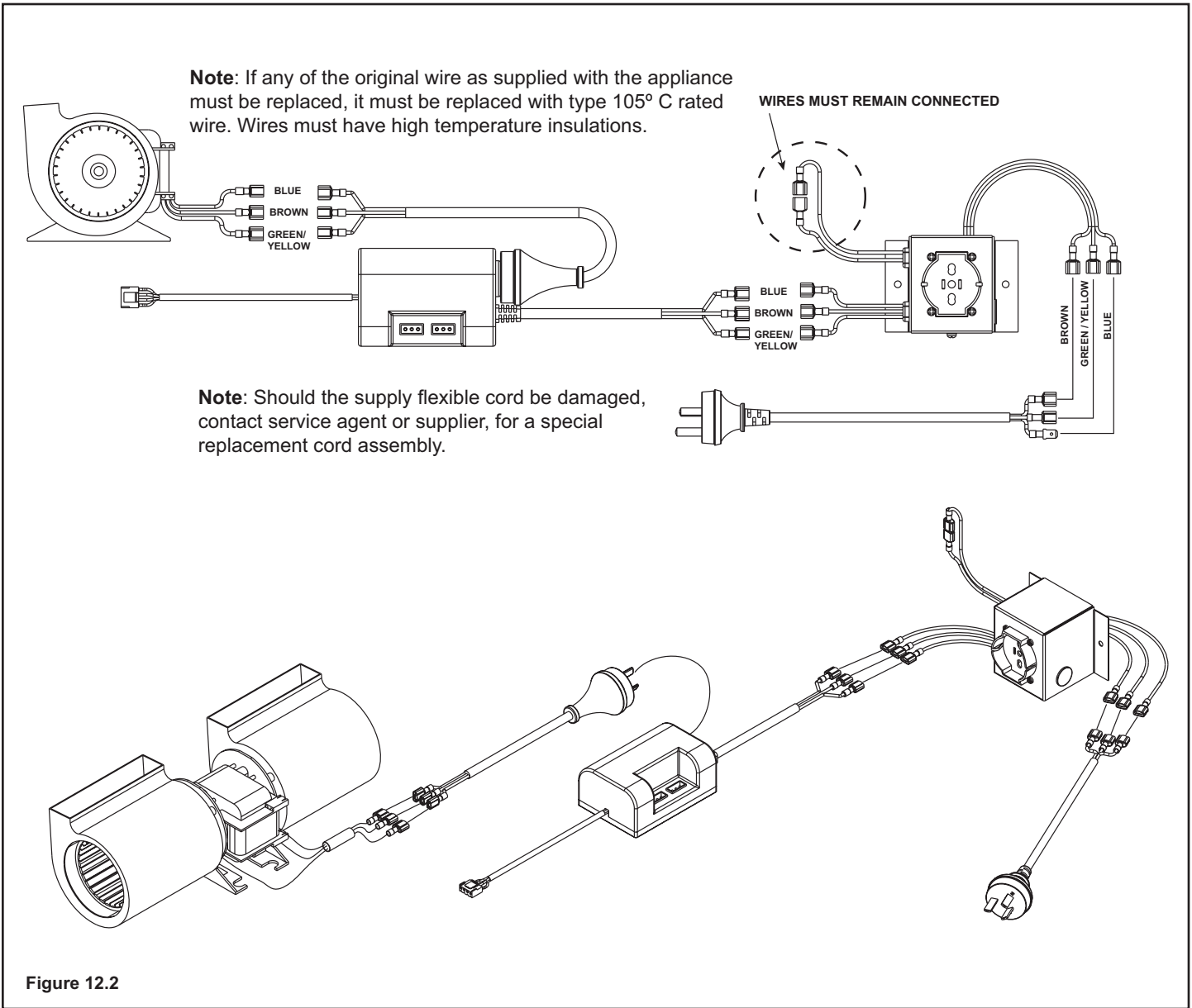

Figure 12.1 IPI Wiring Diagram /RC300AU





**D. Blower**

These heaters have a factory installed fan and electrical junction box. These components are located behind the lower door.

Use of the fan requires that the Junction Box (factory installed) be connected to 220/240 VAC service before permanently enclosing the heater. The access hole for connecting the service wires is found on the right exterior side of the unit. See Figure 12.3 for wire connection detail.

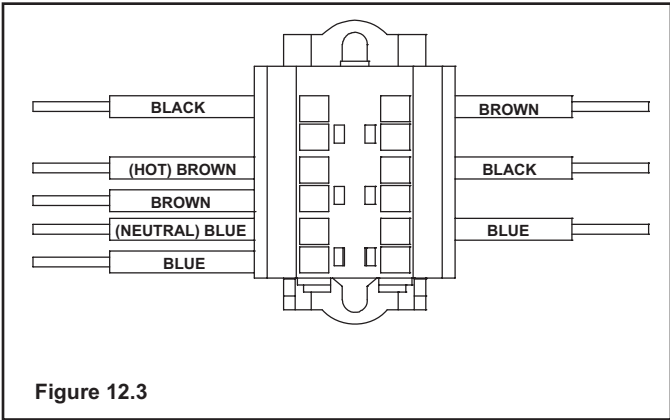



## E. Control Module Operation

1. The control module has an ON/OFF/REMOTE selector switch that must be set. See Figure 12.4.

**OFF Position:** Appliance will ignore all power inputs and will not respond to any commands from a wall switch or remote. The unit should be in the OFF position during installation, service, battery installation, fuel conversion, and in the event that the control goes into LOCK-OUT mode as a result of an error code.

**ON Position:** Appliance will ignite and run continuously in the HI flame setting, with no adjustment in flame output. This mode of operation is primarily used for initial installation or power outage operation with battery backup.

**REMOTE Position:** Appliance will initiate commands from an optional wired wall switch and/or the wireless remote (RC300AU).

2. If using a wired wall switch with the module in REMOTE mode, the flame output can be adjusted with the HI/LO selector switch on the module. See Figure 12.4. Note that the flame HI/LO selector switch will become inactive once an optional remote control (RC300AU) is programmed to the control module. Note that the control module will always ignite the fireplace on HI and remain so for the initial 10 seconds of operation. If the HI/LO is switched to the LO position, the flame output will automatically drop to the lowest setting after the flame has been established for 10 sec. After this 10 second period, the flame can be adjusted from HI to LO with the switch.
3. The control module has safety feature that automatically shuts down the fireplace after 9 hours of continuous operation without receiving a command from the RC300AU remote.
4. If you intend to use both an optional wired wall switch and the RC300AU remote control to operate your fireplace, the wall switch will override any commands given by the remote.
5. The module has the capability to recognize potential malfunctions. If these occur, it will fail to ignite and/or respond to a command to ignite via the wall switch and/or remote. In this case, the module may have gone into LOCK-OUT mode. In this state, it will emit a RED/GREEN LED error code. To reset the error code, switch the selector to OFF, and then back to REMOTE or ON. If the ignition command again fails, the module will emit an LED error code, prior to going back into LOCK-OUT mode. Contact your dealer for service if this occurs.

**Note:** If the module is in LOCK-OUT mode, resetting the circuit breaker to the appliance will also reset the module.

**Note:** For units installed in Australia, the residence's 220/240 wall outlet to which this appliance's power cord is connected, must be wired to an in-line on/off switch. This is required for servicing and/or resetting the control module in the event of a control module LOCK-OUT.

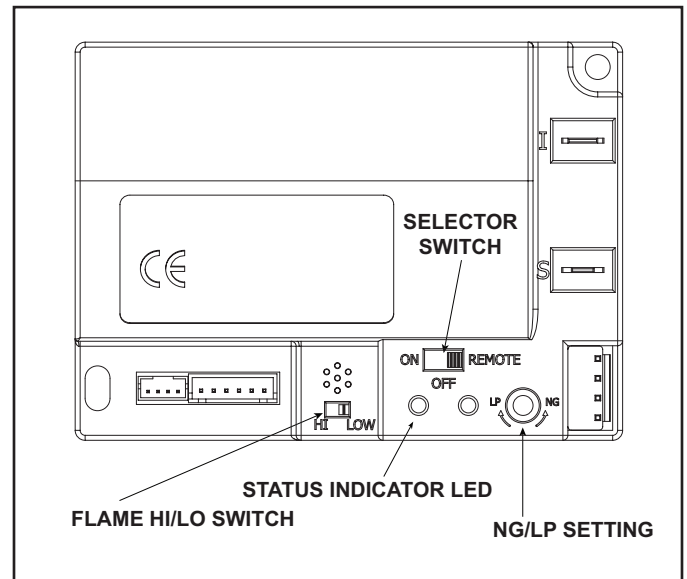

Figure 12.4 Control Module

Hearth & Home Technologies disclaims any responsibility for, and the warranty will be voided by, the following actions:

- Installation and use of any damaged system component.
- Modification of the system component.
- Installation other than as instructed by Hearth & Home Technologies.
- Installation and/or use of any component part not approved by Hearth & Home Technologies.

**Any such action may cause a fire hazard.**

- Read, understand and follow these instructions for safe installation and operation.

## Fireplace Specific Information

Standard fireplace features vary. Consult the installation manual for available options.

The included **AUX300CE** receiver provides additional features: Fan control and two Aux functions.

The **REM300-HNG-AU** remote control system functions include: On/Off, Thermostat Mode, Timer Countdown, and Flame Adjustment (for fireplaces with variable flame).

## Kit Contents

### REM300-HNG-AU

- REM300-HNG-AU Transmitter
- AAA Batteries (3)
- Wall Holder
- Drywall Anchor (2)
- Screws (2)

## Introduction

The RC300AU multifunctional remote control is designed to control pilot light, flame height, blower speed, and up to two 220-240VAC auxiliary functions on your gas fireplace. The RC300AU is equipped with thermostat functions which can automatically control the temperature in the room in which it is installed. The control is only for use with the Hearth & Home Technologies IntelliFire Plus™ system (IPI). The AUX300CE module is rated for 220-240VAC, 50-60 Hz, and is required for operation of this remote control device.

## Installation Precautions

The installation of this remote control must be performed by a qualified service technician. This remote control is tested and safe when installed in accordance with this installation manual. Do not install any components that may be damaged.

Do not modify, disassemble, or substitute any of the components included with this kit. Installation of this unit must be done by a qualified service technician.

Placement of this remote control may affect performance. An assessment of the space should be done prior to installation for optimum performance.

## Determine Location

Determine the location for the remote control. The selected location should be in the same space as the gas fireplace. Never place this unit in a separate room. The remote control must be placed within 30 feet (9.14 m) of the fireplace but should not be exposed to extreme heat.

The RC300AU is approved for interior installation and should not be used in exterior applications.

- Keep remote control out of reach of children.

## FCC Requirements

**WARNING! Risk of Fire!** Changes or modifications to this unit not expressly approved by the party responsible for compliance could void the user's authority to operate the equipment.

**Note:** This equipment has been tested and found to comply with the limits for a Class B digital device, pursuant to Part 15 of the FCC Rules and EN298 for multi-functional control. These limits are designed to provide reasonable protection against harmful interference in a residential installation. This equipment generates, uses, and can radiate radio frequency energy and, if not installed and used in accordance with the instructions, may cause harmful interference to radio communications. However, there is no guarantee that interference will not occur in a particular installation. If this equipment does cause harmful interference to radio or television reception, which can be determined by turning the equipment off and on, the user is encouraged to try to correct the interference by one or more of the following measures:

- Reorient or relocate the receiving antenna.
- Increase the separation between the equipment and receiver.
- Connect the equipment into an outlet on a circuit different from that to which the receiver is connected.
- Contact the dealer or an experienced radio TV technician for help.

## Changing Temperature Scale

To change the temperature display between Celsius and Fahrenheit, remove the battery cover from the back of the remote control and slide the switch to your desired temperature scale (see Figure 12.5). The screen will automatically change the indicators on the room temperature and set temperature portion.

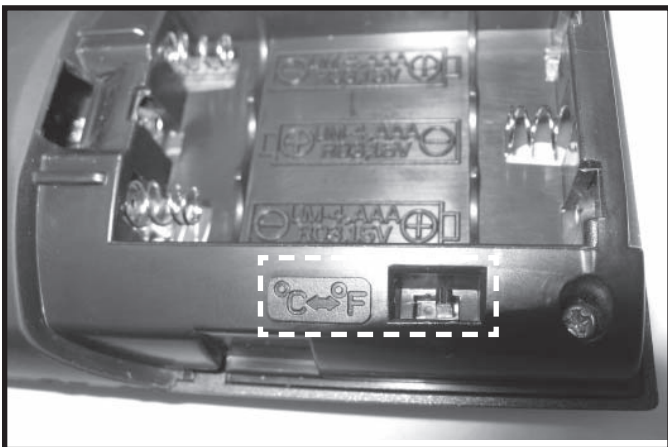

Figure 12.5 Temperature Scale

## Installation of Remote Control Housing

**CAUTION! Risk of Fire! DO NOT** install damaged or modified components. Warranty will be voided if damaged or modified components are installed.

1. Remove remote control components from packaging.
2. Remove battery cover from the back of the remote by sliding it down and install 3 AAA batteries.

To prevent unintended operation when not using your fireplace for an extended period of time (summer months, vacation, trips, etc):

- Remove batteries from remote control.
  - Unplug switching adapter and remove back-up batteries.
3. Secure the remote control housing on a flat wall surface using the two screws and wall anchors provided. See Figure 12.6.

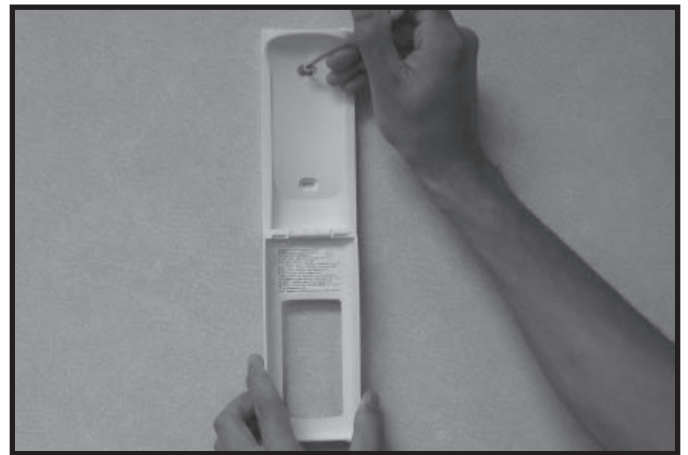

Figure 12.6 Mounting Remote Control Housing

4. Place remote control inside housing. See Figure 12.7.



Figure 12.7 Remote in Housing

5. Close the housing door. See Figure 12.8.



Figure 12.8 Mounting Remote Control Housing

### AUX300CE Module Installation

- Insert the 4 hole harness from the AUX300CE module into the 4 pin plug on the control module. See Figure 12.9.

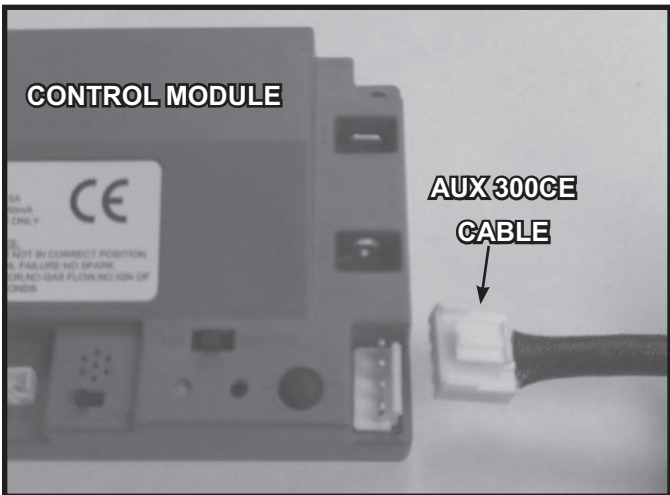

Figure 12.9 AUX 300 module installation

### Fan Installation

- Insert the 3 prong plug from the fan into the receptacle located in the AUX300CE module. See Figure 12.10.
- Insert 3 prong plug from AUX300CE module into REM/AUX receptacle of fireplace junction box.

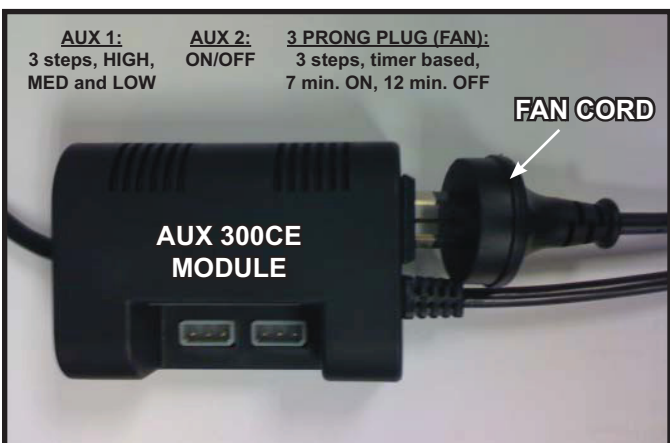

Figure 12.10 Plug Fan into AUX300CE Module

### Programming the RC300AU to the Control Module

**CAUTION! Risk of burns! DO NOT** program the remote control to the control module when fireplace is hot.

- Verify the ON/OFF/REMOTE switch is in the REMOTE position. Green LED light will blink three times and the control module will beep once 5 seconds later when ready. See Figure 7.
- Using a small item (such as a paper clip) press and release the LEARN button located near the ON/OFF/REMOTE switch. See Figure 7.
- Control module will beep once and LED will blink green for 10 seconds.
- While the LED is blinking, press the POWER button on the remote control. A double beep will come out of the control module to indicate that it has been programmed successfully.

**NOTICE:** Up to three remote controls can be programmed into the control module. Simply press a button on the other remote controls during the 10 second programming process to add another remote into the system. It is recommended to program only one RC300AU remote control.

To clear memory in the control module, use a small item (such as a paper clip) to press and release the LEARN button. Control module will beep once and LED will blink green for 10 seconds **DO NOT** press any buttons on the remote during the ten seconds that the green LED blinks. The memory will be cleared. Note that the RC300AU will not be programmed if it's in STANDBY mode. Press the ON/OFF button twice to switch to IDLE mode.

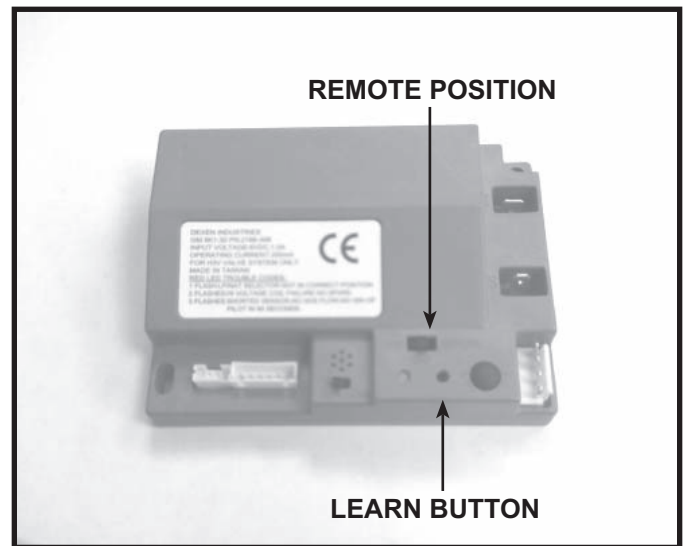
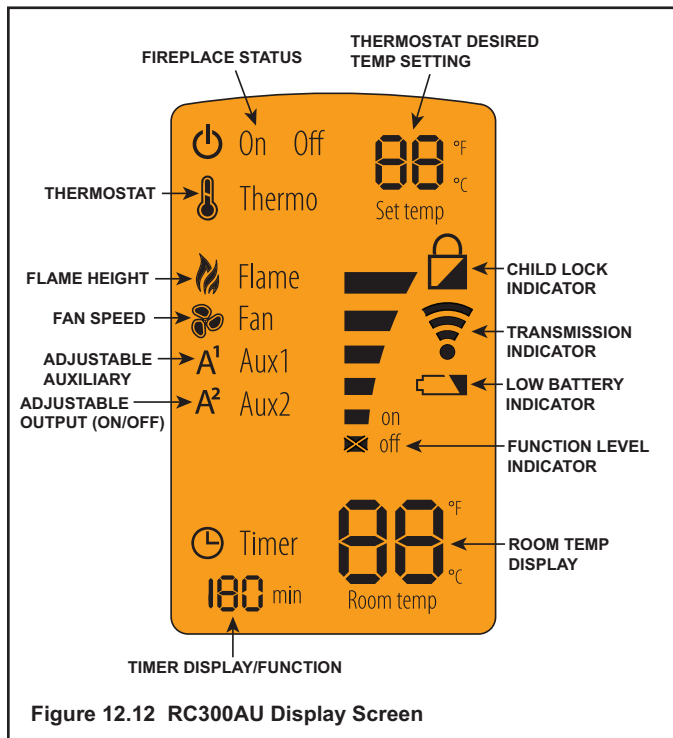

Figure 12.11 Programming RC300AU

## Display Screen



## Function Buttons

- POWER** Use POWER button to turn the unit on and off.
- Menu** Use MENU button to display the menu functions. Only functions that can be activated will be displayed. *For example: Flame Height will not be displayed when the remote status is OFF.*
- Select** Use the SELECT button to select the current feature.
- UP** Use the UP and DOWN arrows to toggle through the menu functions and value selections in the submenus.
- DOWN**

## Idle When Remote is in ON Mode

The remote control will go into an idle mode if no buttons are pressed within 5 seconds. Press any button to resume full functionality. In idle mode only active functions will show on the screen.



## Standby mode

The remote control will go into a standby mode if no buttons are pressed within 5 minutes. Press the POWER button to reactivate the remote control to ON mode. Active functions will be displayed

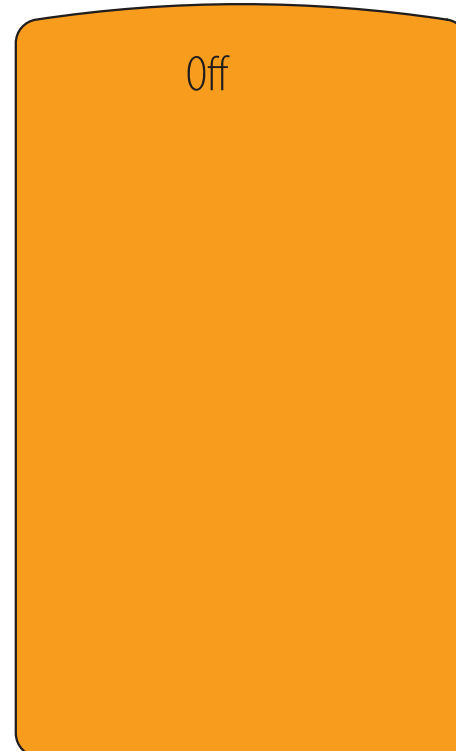



## About ON Mode

- All functions can be accessed when the remote control is in the ON mode.
- Only active functions will be displayed when the remote control is in the ON mode. For example: if the fan is the only function that's active, the fan icon and flame will be the only icon shown in the display.

## About OFF Mode

Only the following functions can be accessed in the OFF mode:

- AUX1
- AUX2

Only active functions will be displayed when the remote control is in the OFF mode.

## Turning ON the Fireplace

- Press and hold the POWER button for 5 seconds to unlock remote, back light will illuminate. Press the POWER button again to turn the fireplace ON. The fireplace will first ignite the pilot. The main burner will be lit, once the pilot flame has been established. The remote will be locked again when the fireplace is turned OFF.

**NOTICE:** Whenever the fireplace is cycled from OFF to ON, the main burner will light on high for 10 seconds before returning to the previous user setting.

## Adjusting Flame Height

- Press the MENU button to activate the menu.
- Using the UP and DOWN arrows highlight the FLAME icon and press SELECT.
- Use the UP and DOWN arrows to adjust the FLAME HEIGHT, then press SELECT. The FLAME HEIGHT can be adjusted to 5 different settings.

**NOTICE:** FLAME HEIGHT will not be adjustable for first ten seconds when fireplace is turned on.

**NOTICE:** The system will remember the previous FLAME HEIGHT setting and will automatically adjust after 10 seconds.

## Adjusting Fan Speed

- Press the MENU button to activate the menu.
- Using the UP and DOWN arrows highlight the FAN icon and press SELECT.
- Use the UP and DOWN arrows to adjust the FAN SPEED, then press SELECT. The FAN SPEED can be adjusted to 3 different settings: HIGH, MEDIUM, LOW.

**NOTICE:** The fan has a timer built into the control module. After the fireplace is turned ON the timer will wait for 7 minutes before turning on the fan. In addition, the fan will remain on for 12 minutes after the fireplace has been turned OFF.

**NOTICE:** Whenever the fan is turned ON, the FAN will start up on the high setting for 10 seconds before adjusting to the previous user setting.

## AUX1 Function (Unit dependent Function)

- Press the MENU button to activate the menu.
- Using the UP and DOWN arrows highlight the AUX1 icon and press SELECT.
- Use the UP and DOWN arrows to adjust the AUX1 output, then press SELECT. The AUX1 function can be adjusted to 4 different settings: HI, MED, LOW and OFF.

## AUX2 Function (Unit dependent Function)

- Press the MENU button to activate the menu.
- Using the UP and DOWN arrows highlight the AUX2 icon and press SELECT.
- Use the UP and DOWN arrows to turn the AUX2 ON or OFF, then press SELECT. The AUX2 function can be either be turned ON or OFF.

**NOTICE:** When the fireplace is turned OFF both AUX1 and AUX2 will be turned off. The AUX1 and AUX2 functions can be activated from the remote's OFF mode, when the flame is off. When the fireplace is turned back ON, the AUX1 and AUX2 settings will be restored to the previous setting. ←



## Adjusting Thermostat

- Press the **MENU** button to activate the menu.
- Using the **UP** and **DOWN** arrows highlight the **THERMO** icon and press **SELECT**.
- Use the **UP** and **DOWN** arrows to turn the **THERMO ON** or **OFF**, then press **SELECT** (the **SET TEMP** will start blinking). Using the **UP** and **DOWN** arrows select the desired temperature and press **SELECT**.

**NOTICE:** If the **THERMO** function is on, the **SET TEMP** can be adjusted at any time by pressing the **UP** and **DOWN** arrows.

**NOTICE:** As the **ROOM TEMP (RT)** approaches **SET TEMP (ST)**, the remote system will automatically adjust the flame height. If the **RT** rises above **ST**, the fireplace will shut down the main burner. After this, the fireplace will turn back on after the **RT** drops below the **ST**.

**NOTICE:** The system will remember the previous **TEMPERATURE** setting when **THERMOSTAT** mode is cycled **ON** or **OFF**.

**NOTICE:** If your installation includes an optional wired **ON/OFF** wall switch, it should be in the **OFF** position when using the **RC300AU** in thermostat mode.

## Adjusting Timer

- Press the **MENU** button to activate the menu.
- Using the **UP** and **DOWN** arrows highlight the **TIMER** icon and press **SELECT**.
- Use the **UP** and **DOWN** arrows to turn the **TIMER ON** or **OFF**, then press **SELECT**. Using the **UP** and **DOWN** arrows select the desired set time and press **SELECT**. Timer operates in increments of 15, 30, 45, 60, 90, 120 and 180 minutes.

## Setting the Child Lock

- Press and hold the **MENU** and **UP** arrow buttons simultaneously for 4 seconds to enable or disable the child lock feature.

**NOTICE:** No functions will be usable until child lock feature is disabled.

## Power Outage

- If fireplace battery backup system IS installed at time of power outage, fireplace operation will not be interrupted.
- If fireplace battery backup system IS NOT installed at time of power outage, fireplace will shut off. To resume fireplace operation, install battery backup.

**NOTICE:** Battery polarity must be correct or module damage will occur.

## Manual Fireplace Shutoff

In the unlikely event that the remote wall switch malfunctions and will not turn off the fireplace, call your dealer for service assistance. In the meantime, you may choose one of the following actions to turn off the fireplace:

**CAUTION! Risk of burns!** Fireplace surfaces are hot when operating and during cool down. Use care and wear gloves when opening the front and accessing components inside the fireplace.

Check remote screen for battery level indicator, replace the batteries if low battery is indicated (See Figure 12.12).

The fireplace may be manually shut down by one of the following methods:

### Turn off the control module:

- Open or remove the decorative front to access the control module.
- Move switch to **OFF**.

### Disconnect power to the control module:

- Open or remove the decorative front to access power cord to the junction box and/or back-up batteries.
- Unplug the control module and/or remove back-up batteries.

### Shut off gas to the appliance:

- Open or remove the decorative front and locate the gas shut-off valve to the left of the gas control. ←
- Rotate the shut off valve 90 degrees to turn off gas supply. ←

### Turn off power to the fireplace (if back-up batteries are not installed):

- Locate house circuit breaker for fireplace.
- Turn off the circuit breaker.

## Frequently Asked Questions/Troubleshooting

Symptom	Possible Cause	Corrective Action
Remote control will not transmit	Batteries	Verify batteries are functional and installed correctly.
	Remote control is in Child Lock mode	Disengage Child Lock mode.
	Buttons not being pressed firmly	Press button firmly for one to two seconds to ensure transmission to module.
Control module will not take commands from remote control	Control module is not in "REMOTE" mode	Ensure module switch is set to REMOTE.
	Control module and remote control are not programmed to each other	The control module will beep when it successfully receives a command. If it does not beep, clear module memory and reprogram the remote control.
	Control module is unplugged. In case of power outage, backup batteries are depleted or missing	If the transmission indicator comes on when power button is pressed, verify that the control module is plugged in the fireplace junction box located in the controls area. Also verify that the batteries are installed in the battery pack.
Fan does not turn on when fireplace is started	Built in time delay	The fireplace must run for seven minutes in order for the fan to engage.
Fan does not turn off when fireplace turned off	Built in time delay	The fan will run for twelve minutes after the fireplace is turned off.
Fireplace shuts down after extended periods	Built-in timer	The fireplace will automatically shut down after nine hours of continuous operation if it does not receive a command from the remote.
Fireplace is on but will not shut off with the remote control	External wired wall switch	The fireplace cannot be turned off by remote if an external wired switch is installed and in the ON position. Turn external wall switch to OFF.
	Remote control or control module failure	At control module, turn off fireplace by sliding the ON/OFF/REMOTE switch to OFF. Warning! Risk of Burns! Fireplace is hot. Use caution when accessing module.

# 13 Finishing

## A. Mantel and Wall Projections

**WARNING! Risk of Fire!** Comply with all minimum clearances as specified. Framing closer than the minimums listed must be constructed entirely of noncombustible materials (i.e., steel studs, concrete board, etc.)

### Combustible Mantels

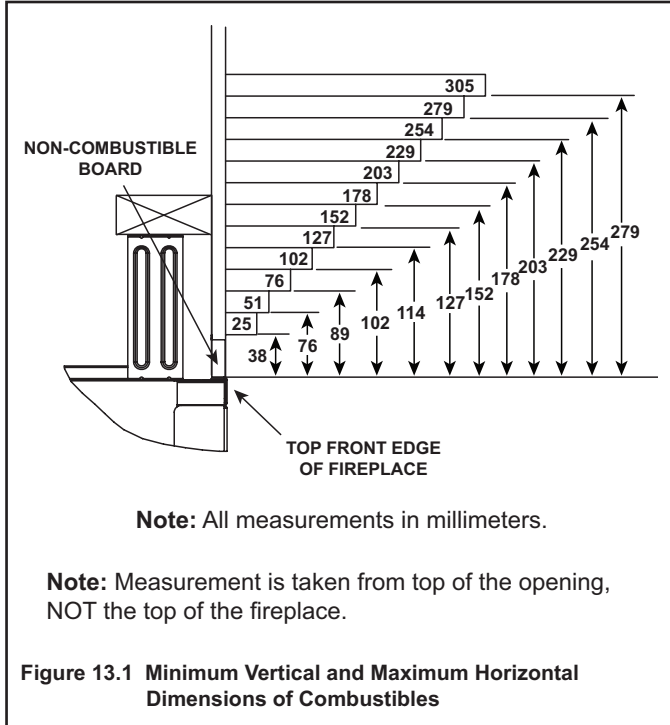

### Combustible Mantel Legs or Wall Projections

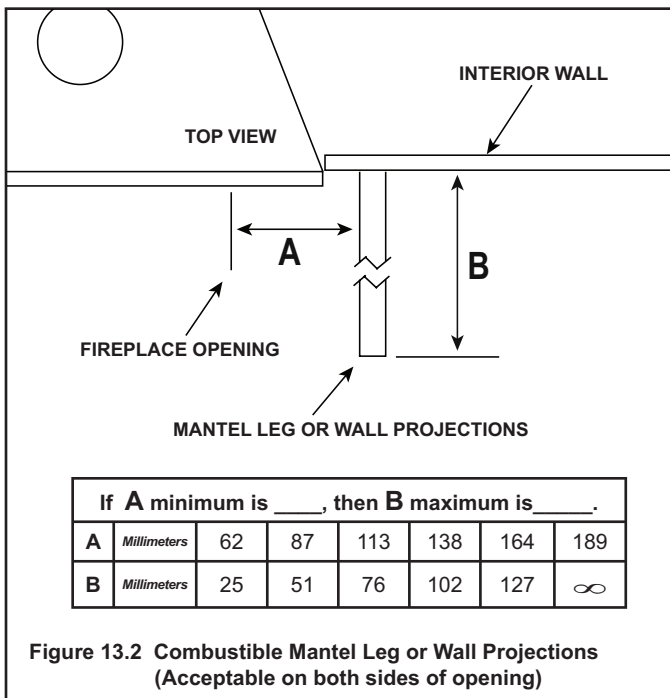

## B. Facing Material

- Metal front faces may be covered with non-combustible materials only.
- Facing and/or finishing materials must not interfere with air flow through louvers, operation of louvers or doors, or access for service.
- Facing and/or finishing materials must never overhang into the glass opening.
- Observe all clearances when applying combustible materials.
- Seal joints between the finished wall and appliance top and sides using a 300° F (149° C) minimum sealant.

**WARNING! Risk of Fire! DO NOT** apply combustible materials beyond the minimum clearances. Comply with all minimum clearances to combustibles as specified in this manual. Overlapping materials could ignite and will interfere with proper operation of doors and louvers.

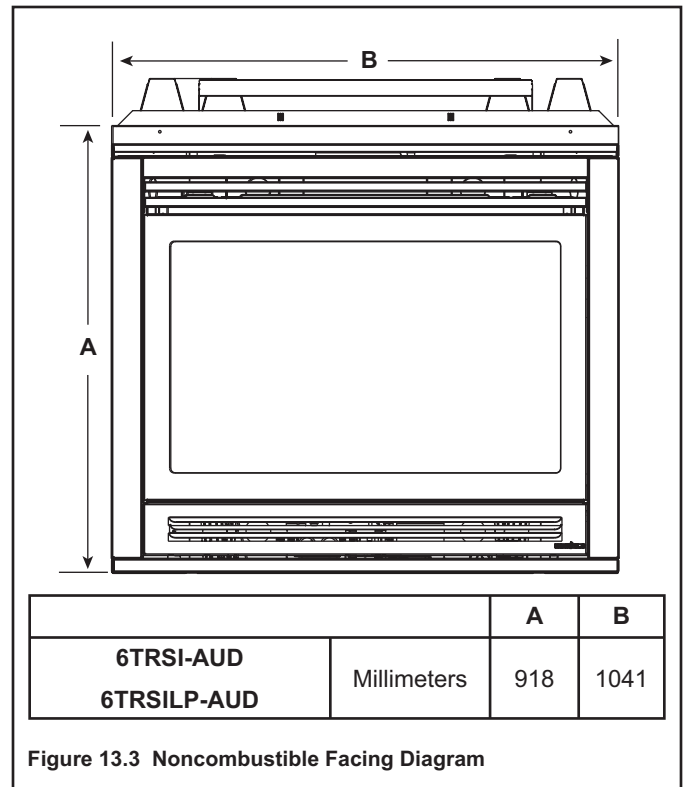

# 14 Appliance Setup

---

## A. Remove Fixed Glass Assembly

See Section 9.E.

## B. Remove the Shipping Materials

Remove shipping materials from inside or underneath the firebox.

## C. Clean the Appliance

Clean/vacuum any sawdust that may have accumulated inside the firebox or underneath in the control cavity.

## D. Accessories

Install approved accessories per instructions included with accessories. Contact your dealer for a list of approved accessories.

***WARNING! Risk of Fire and Electric Shock! Use ONLY Hearth & Home Technologies-approved optional accessories with this appliance. Using non-listed accessories could result in a safety hazard and will void the warranty.***

**DO NOT MODIFY THIS APPLIANCE**

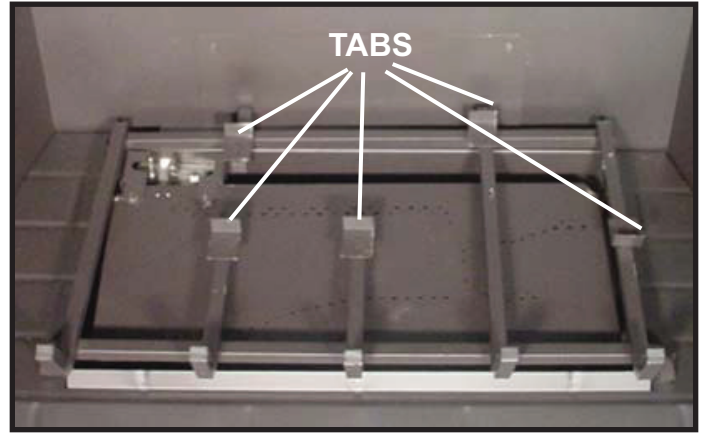

**CAUTION:** Logs are fragile! Carefully remove the logs from the packaging.



**LOG #1 (SRV2049-700):** Locate log #1 by placing log notches on the second and fifth grate bars and push log against rear log locators.



**LOG #2 (SRV2049-701):** Locate log #2 on grate with notches. Slide back against tabs.







**LOG #3 (SRV385-721):** Rest log #3 in the groove on log #1 with its lower portion resting against the left side wall.



→ **LOG #4 (SRV385-722):** Place log #4 on 5th grate tines and rest its top into the groove on log #1.



→ **LOG #5 (SRV385-723):** Position log #5 between the 3rd and 4th grate tines resting on the grooves in log #1 and log #2.



# 15 Troubleshooting

With proper installation, operation, and maintenance your gas appliance will provide years of trouble-free service. If you do experience a problem, this troubleshooting guide will assist a qualified service technician in the diagnosis of a problem and the corrective action to be taken. This troubleshooting guide can only be used by a qualified service technician. Contact your dealer to arrange a service call by a qualified service technician.

## A. IntelliFire Plus™ Ignition System

Symptom	Possible Cause	Corrective Action
1. Pilot won't light. The ignitor/module makes noise, but no spark.	A. Incorrect wiring.	Verify "S" wire (white) for sensor and "I" wire (orange) for ignitor are connected to correct terminals on module and pilot assembly.
	B. Loose connections or electrical shorts in the wiring.	Verify no loose connections or electrical shorts in wiring from module to pilot assembly. Verify connections underneath pilot assembly are tight; also verify igniter and flame sense wires are not grounding out to metal chassis, pilot burner, pilot enclosure, mesh screen if present, or any other metal object.
	C. Ignitor gap is too large.	Verify gap of igniter to right side of pilot hood. The gap should be approximately .17 in. or 1/8 in. (3 mm).
2. Pilot won't light, there is no noise or spark.	A. No power, transformer installed incorrectly, or depleted batteries.	Verify that transformer is installed and plugged into module. Check voltage of transformer at connection to module. Acceptable readings of a good transformer are between 6.4 and 6.6 volts AC. Battery power supply voltage must be at least 4 volts. If less than 4 volts, replace batteries.
	B. A shorted or loose connection in wiring configuration or wiring harness.	Remove and reinstall the wiring harness that plugs into module. Verify there is a tight fit. Verify pilot assembly wiring to module. Remove and verify continuity of each wire in wiring harness. Replace any damaged components.
	C. Improper wall switch wiring.	Verify that 220/240 VAC power is "ON" to junction box.
	D. Module not grounded.	Verify black ground wire from module wire harness is grounded to metal chassis of appliance.
3. Pilot sparks, but Pilot will not light.	A. Gas supply.	Verify that incoming gas line ball valve is "open". Verify that inlet pressure reading is within acceptable limits.
	B. Ignitor gap is too large.	Verify gap of igniter to right side of pilot hood. The gap should be approximately .17 in. or 1/8 in. (3 mm).
	C. Module is not grounded.	Verify module is securely grounded to metal chassis of appliance.
	D. Pilot valve solenoid.	Verify that 1.5 to 1.8 VDC is supplied to pilot solenoid from module. If below 1.5 volts, replace module. If 1.5 volts or greater, replace valve.

## Troubleshooting (continued)

Symptom	Possible Cause	Corrective Action
4. Pilot lights but continues to spark, and main burner will not ignite. (If the pilot continues to spark after the pilot flame has been lit, flame rectification has not occurred.)	A. A shorted or loose connection in flame sensing rod.	Verify all connections to wiring diagram in manual. Verify connections underneath pilot assembly are tight. Verify flame sense or igniter wires are not grounding out to metal chassis, pilot burner, pilot enclosure or screen if present, or any other metal object.
	B. Poor flame rectification or contaminated flame sensing rod.	With fixed glass assembly in place, verify that flame is engulfing flame sensing rod on left side of pilot hood. Flame sensing rod should glow shortly after ignition. With a multi-meter, verify that current in series between module and sense lead is at least 0.14 microamps. Verify correct pilot orifice is installed and gas inlet is set to pressure specifications. Clean flame sensing rod with emery cloth to remove any contaminants that may have accumulated on flame sensing rod.
	C. Module is not grounded.	Verify module is securely grounded to metal chassis of appliance. Verify that wire harness is firmly connected to the module.
	D. Damaged pilot assembly or contaminated flame sensing rod.	Verify that ceramic insulator around the flame sensing rod is not cracked, damaged, or loose. Verify connection from flame sensing rod to white sensor wire. Clean flame sensing rod with emery cloth to remove any contaminants that may have accumulated on flame sensing rod. Verify continuity with a multi-meter with ohms set at lowest range. Replace pilot if any damage is detected.
5. Carbon Deposition	A. Log Placement	Verify placement and assure flame is not excessively impinging on log.
	B. Shutter Setting	Check to assure correct shutter setting for your model and gas type.
	C. Gas Type	Assure correct fuel matches unit gas model and components.

# 16 Reference Materials

## A. Appliance Dimension Diagram

Dimensions are actual appliance dimensions. Use for reference only. For framing dimensions and clearances refer to Section 5.

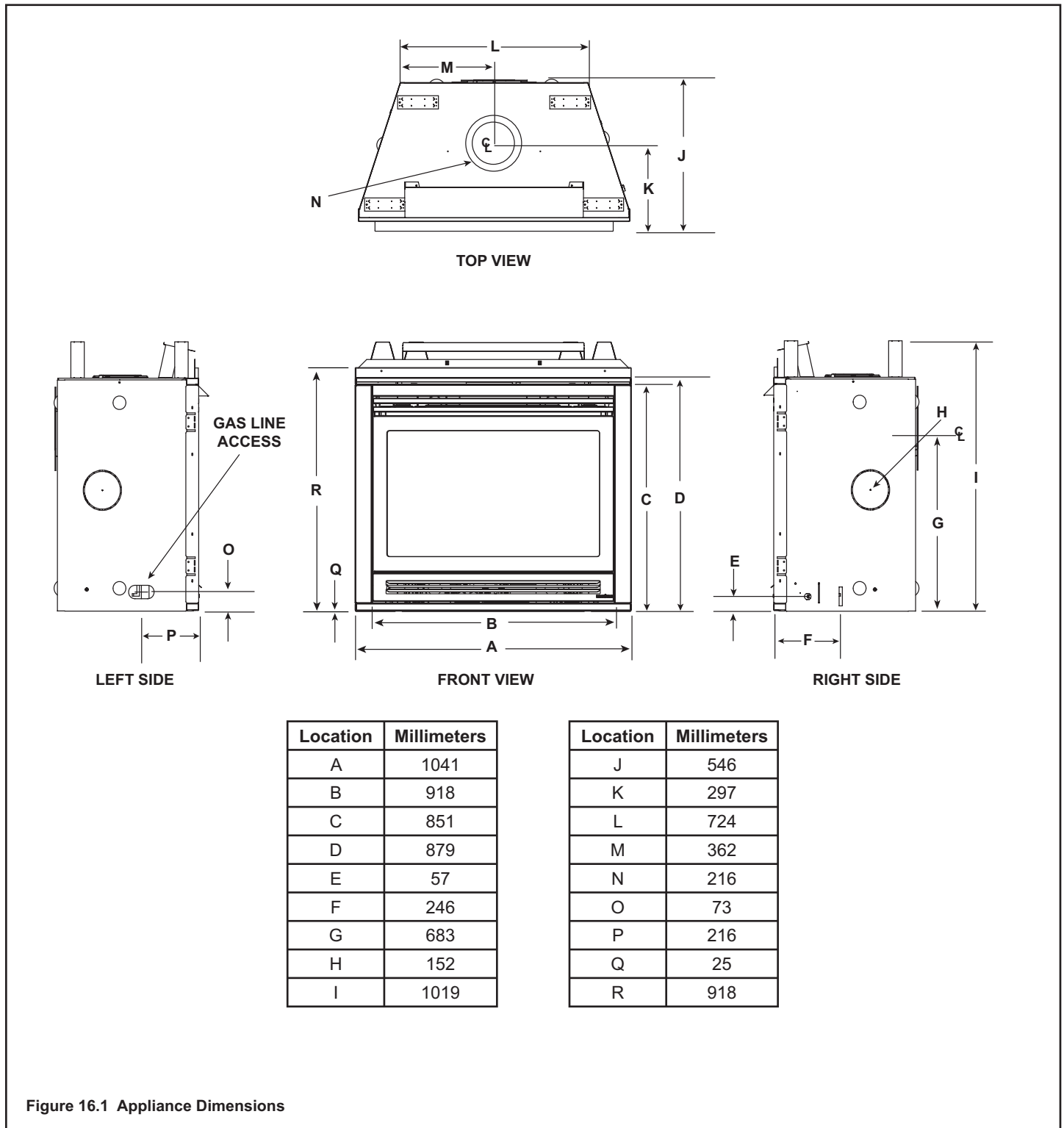
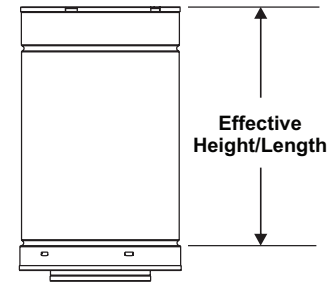

Figure 16.1 Appliance Dimensions

## B. Maintenance Tasks

Inspect	Maintenance Tasks
Doors	1. Inspect for scratches, dents or other damage and repair as necessary.
	2. Verify no obstructions to airflow.
	3. Verify maintenance of proper clearance to combustible household objects.
Gasket Seal, Glass Assembly and Glass	1. Inspect gasket seal and its condition.
	2. Inspect glass panels for scratches and nicks that can lead to breakage when exposed to heat.
	3. Confirm there is no damage to glass or glass frame. Replace as necessary.
	4. Verify that latches engage properly, clip studs are not stripped, and glass attachment components are intact and operating properly. Replace as necessary.
	5. Clean glass. Replace glass assembly if severely coated with silicate deposits that cannot be removed.
Valve Compartment and Firebox Top	1. Vacuum and wipe out dust, cobwebs, debris or pet hair. Use caution when cleaning these areas. Screw tips that have penetrated the sheet metal are sharp and should be avoided.
	2. Remove any foreign objects.
	3. Verify unobstructed air circulation.
Logs	1. Inspect for broken, damaged, or missing logs. Replace as necessary.
	2. Verify correct log placement and no flame impingement causing sooting. Correct as necessary.
Firebox	1. Inspect for paint condition, warpage, corrosion or perforation. Sand and repaint as necessary.
	2. Replace appliance if firebox has been perforated.
Burner Ignition and Operation	1. Verify burner is properly secured and aligned with pilot or igniter.
	2. Clean off burner top, inspect for plugged ports, corrosion or deterioration. Replace burner if necessary.
	3. Replace ember materials with new dime-size and shape pieces. Do not block ports or obstruct lighting paths.
	4. Check for smooth lighting and ignition carryover to all ports. Verify there is no ignition delay.
	5. Inspect for lifting or other flame problems.
	6. Inspect orifice for soot, dirt or corrosion.
	7. Verify manifold and inlet pressures. Adjust regulator as required.
	8. Inspect pilot flame strength. Clean or replace orifice as necessary.
	9. Inspect thermocouple/thermopile or IPI sensor rod for soot, corrosion and deterioration. Clean with emery cloth or replace as required.
Flueing	1. Inspect venting for blockage or obstruction such as bird nests, leaves, etc.
	2. Confirm that termination cap remains clear and unobstructed by plants, etc.
	3. Verify that termination cap clearance to subsequent construction (building additions, decks, fences or sheds) has been maintained.
	4. Inspect for corrosion or separation.
	5. Verify weather stripping, sealing and flashing remains intact.
Remote controls	1. Verify operation of remote.
	2. Replace batteries in remote transmitters and battery-powered receivers.
→ Carbon Deposition	1. Appliances incorporating a live fuel effect, and designed to operate with luminous flames, may exhibit slight carbon deposition.

### C. Vent Components Diagrams



Effective Height/Length

DVP Pipe (see chart)

Pipe	Effective Length	
	Inches	Millimeters
DVP4	4	102
DVP6	6	152
DVP12	12	305
DVP24	24	610
DVP36	36	914
DVP48	48	1219
DVP6A	3 to 6	76 to 152
DVP12A	3 to 12	76 to 305
DVP12MI	3 to 12	76 to 305
DVP24MI	3 to 24	76 to 610

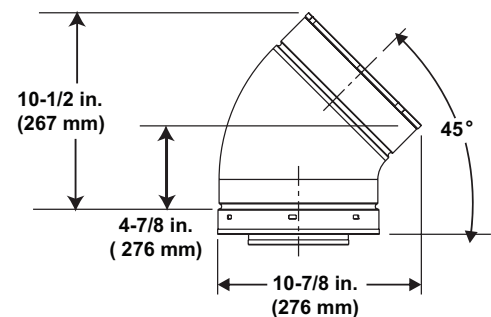

DVP45 (45° Elbow)

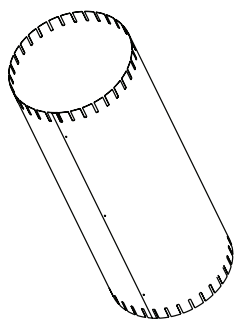

Assembled Height: 24 in./610 mm  
Diameter: 10 in./254 mm

DVP-AS2

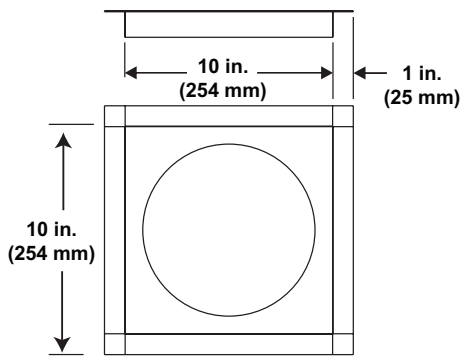

DVP-FS (Ceiling Firestop)

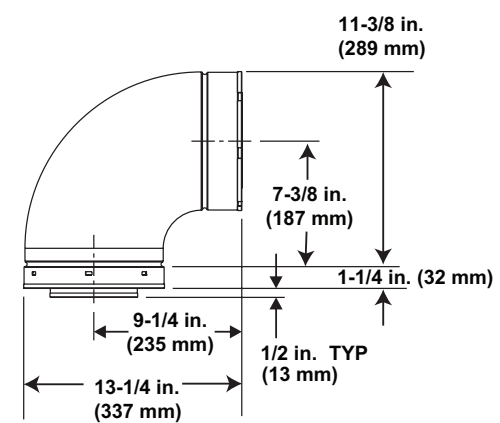

DVP90ST (90° Elbow)

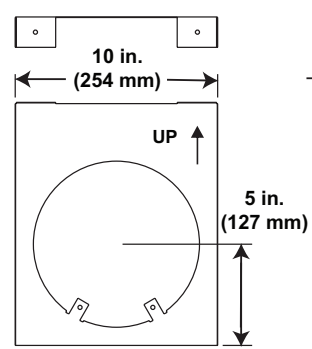

DVP-HVS (Vent Support)

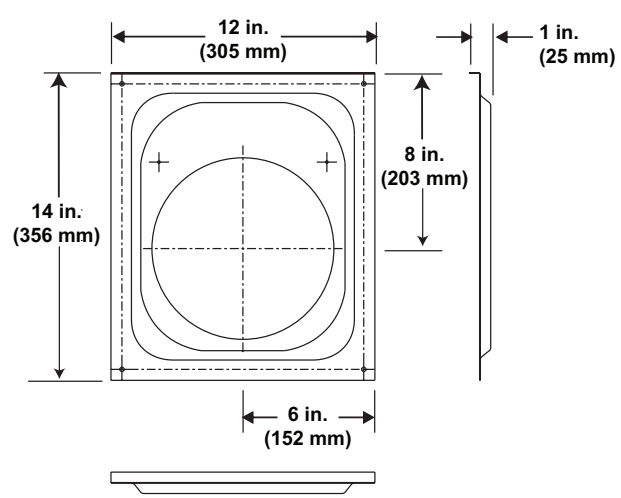
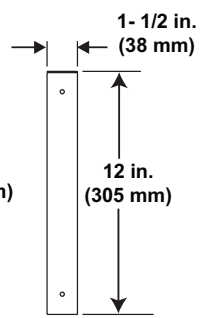

DVP-WS (Wall Shield Firestop)

Figure 16.3 DVP vent components

## C. Vent Components Diagrams (continued)

Note: Heat shields **MUST** overlap by a minimum of 1-1/2 in. (38 mm). **The heat shield is designed to be used on a wall 4 in. to 7-1/4 in. (102 mm to 184 mm) thick.** If wall thickness is less than 4 in. (102 mm) the existing heat shields must be field trimmed. If wall thickness is greater than 7-1/4 in. (184 mm) a DVP-HSM-B will be required.

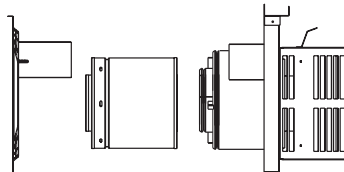
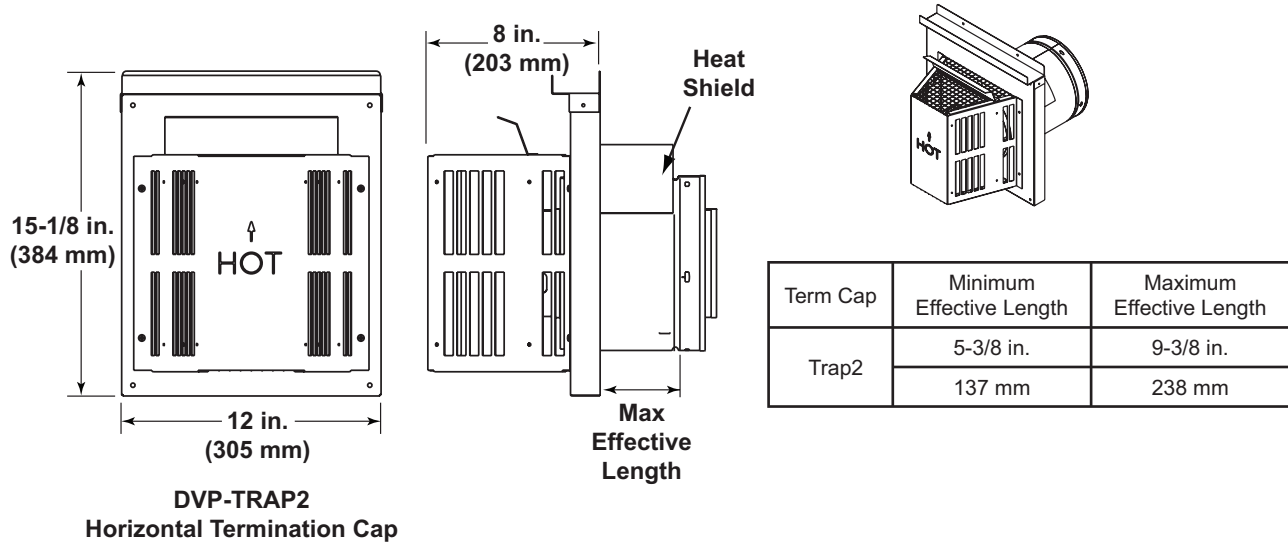

**DVP-TRAP2**

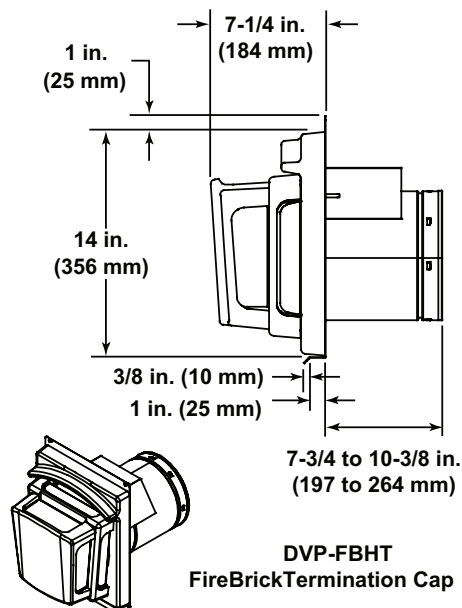
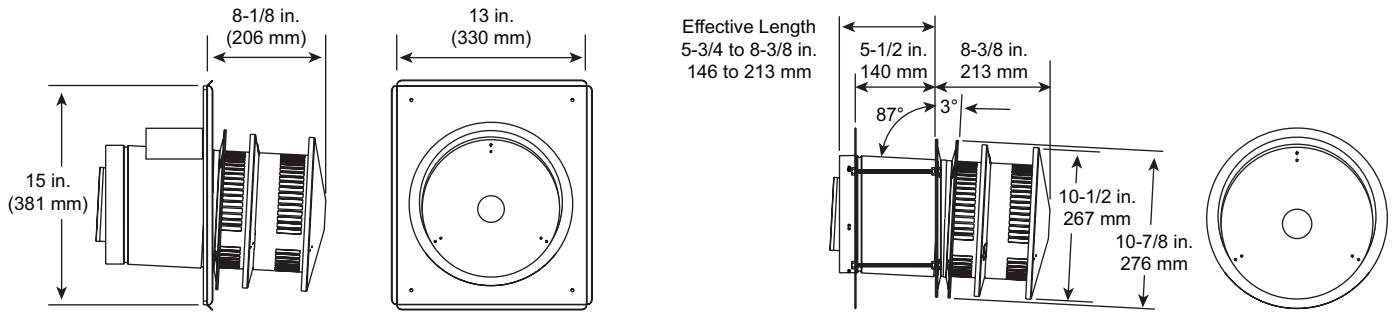

Figure 16.4 DVP vent components



## C. Vent Components Diagrams (continued)



**DVP-HRC-SS  
DVP-HRC-ZC-SS  
Horizontal Termination Cap**

### ⚠ WARNING



Fire Risk.

- When using DVP-HRC-SS and DVP-HRC-ZC-SS termination caps on top vented fireplaces, a 6 inch (152 mm) minimum vertical vent section is required before installing first elbow.

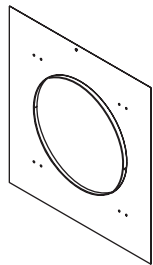

**DVP-TRAPFL  
Flashing**

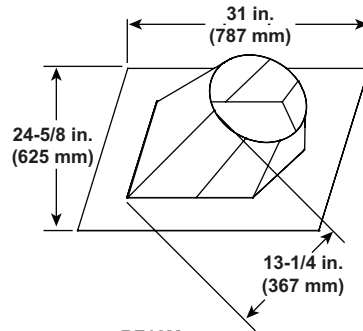

**RF12M  
Roof Flashing Multi-pak**

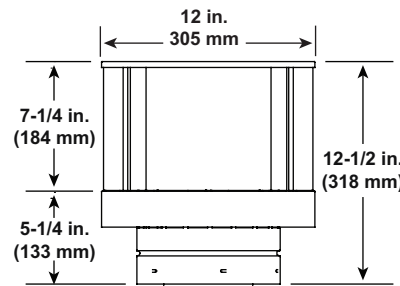

**DVP-TVHW  
Vertical Termination Cap (Highwind)**

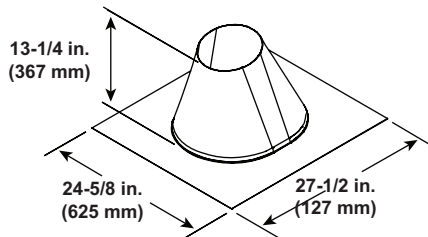

**RF6M  
Roof Flashing Multi-pak**

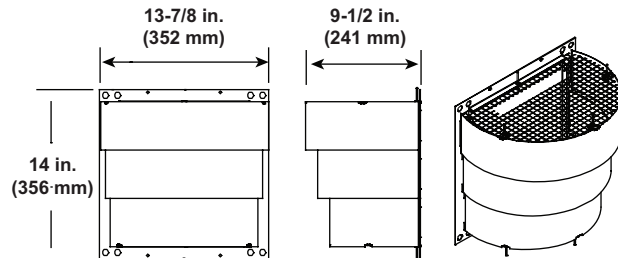

**DRC-RADIUS  
Cap Shield**

Figure 16.5 DVP vent components

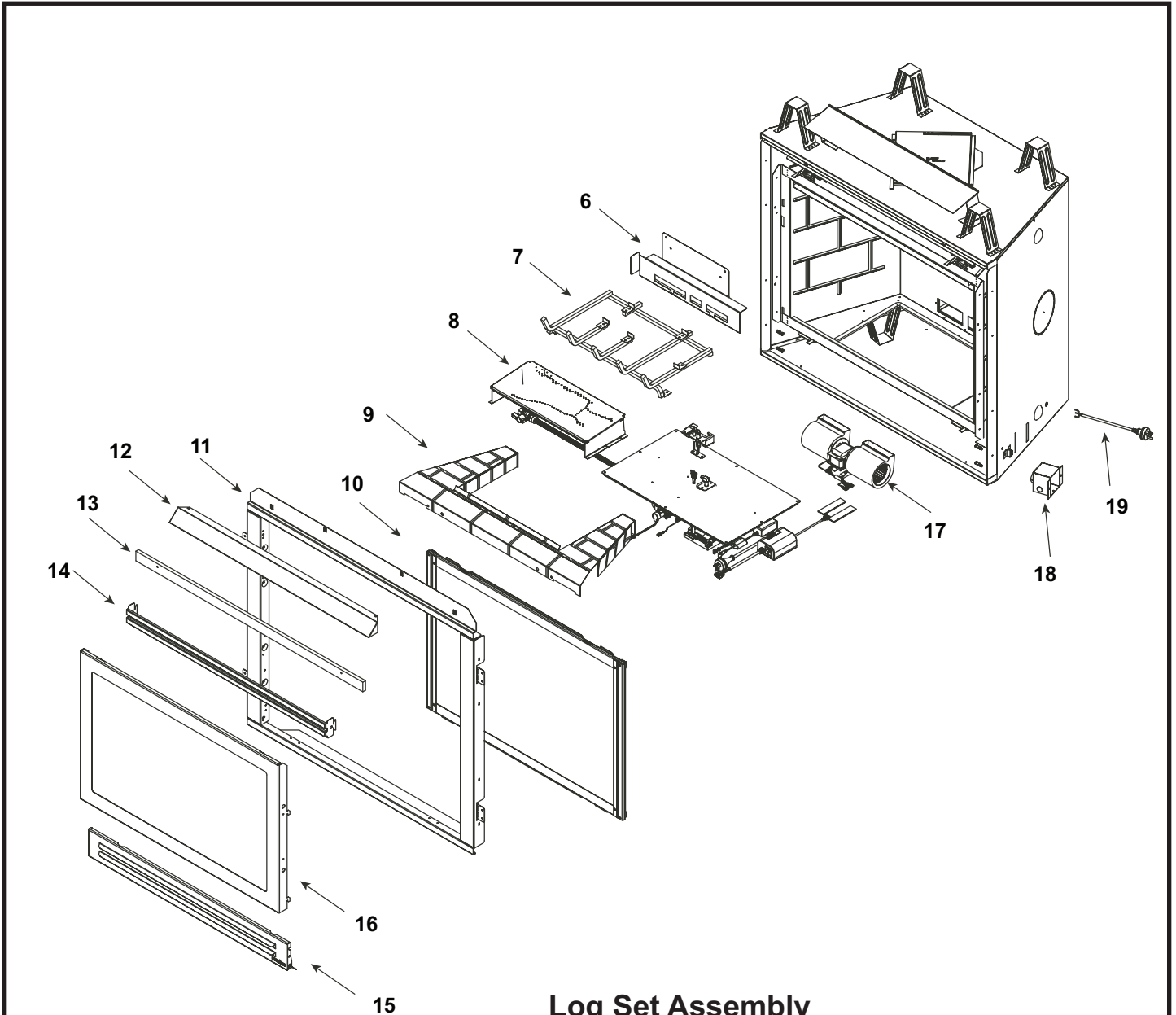

### Log Set Assembly

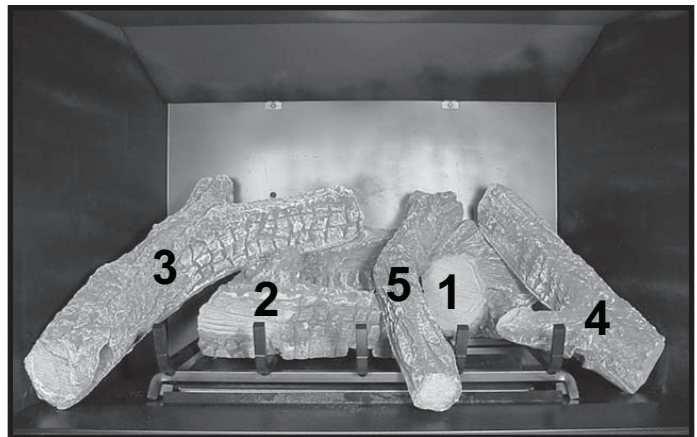

Part number list on following page.

## Service Parts List

## 6TRSI-AUD, 6TRSILP-AUD

IMPORTANT: THIS IS DATED INFORMATION. When requesting service or replacement parts for your appliance please provide model number and serial number. All parts listed in this manual may be ordered from an authorized dealer.

ITEM	DESCRIPTION	COMMENTS	PART NUMBER
	Log Set Assembly		LOGS-6TRSCE
1	Log #1		SRV2049-700
2	Log #2		SRV2049-701
3	Log #3		SRV385-721
4	Log #4		SRV385-722
5	Log #5		SRV385-723
6	Air Guide		2078-107
7	Grate Assembly		2049-020
8	Burner Assembly, N		2078-010
	Burner Assembly, P		2078-012
	Burner Assembly, B		2078-014
9	Base Refractory		2078-110
10	Glass Assembly		GLA-6GLX
11	Surround Assembly		2166-019
12	Hood, Black		SRV60-143-BK
13	Insulation Board		385-401
14	Top Louver Assembly		392-182A
15	Lower Door Assembly		2078-042
16	Dress Guard		2078-040
17	Blower 240Volt Assembly		GFK-240V
18	Junction Box, 240V		2078-027
19	Power Cord, 240V		546-251A
	Exhaust Baffle		2078-100
	Gasket Assembly		2166-081
	Glass Latch Support Assembly	Qty 4 req	33858
	Heat Shield, Control Module		2078-121
	Mineral Wool		050-721
	RC300AU Remote		REM300-HNG-AU
	Touch-Up Paint, 12 oz Can		TUP-GBK-12
	<b>Conversion Kits</b>		
	Propane/Butane to Natural		PB2N-6I-AUD
	Propane to Butane		P2B-6I-AUD
	Natural to Propane		N2P-6I-AUD
	Natural to Butane		N2B-6I-AUD
	Pilot Orifice N (.0181)		2098-518
	Pilot Orifice P/ B (.0121)		2098-512

Additional service part numbers appear on following page.

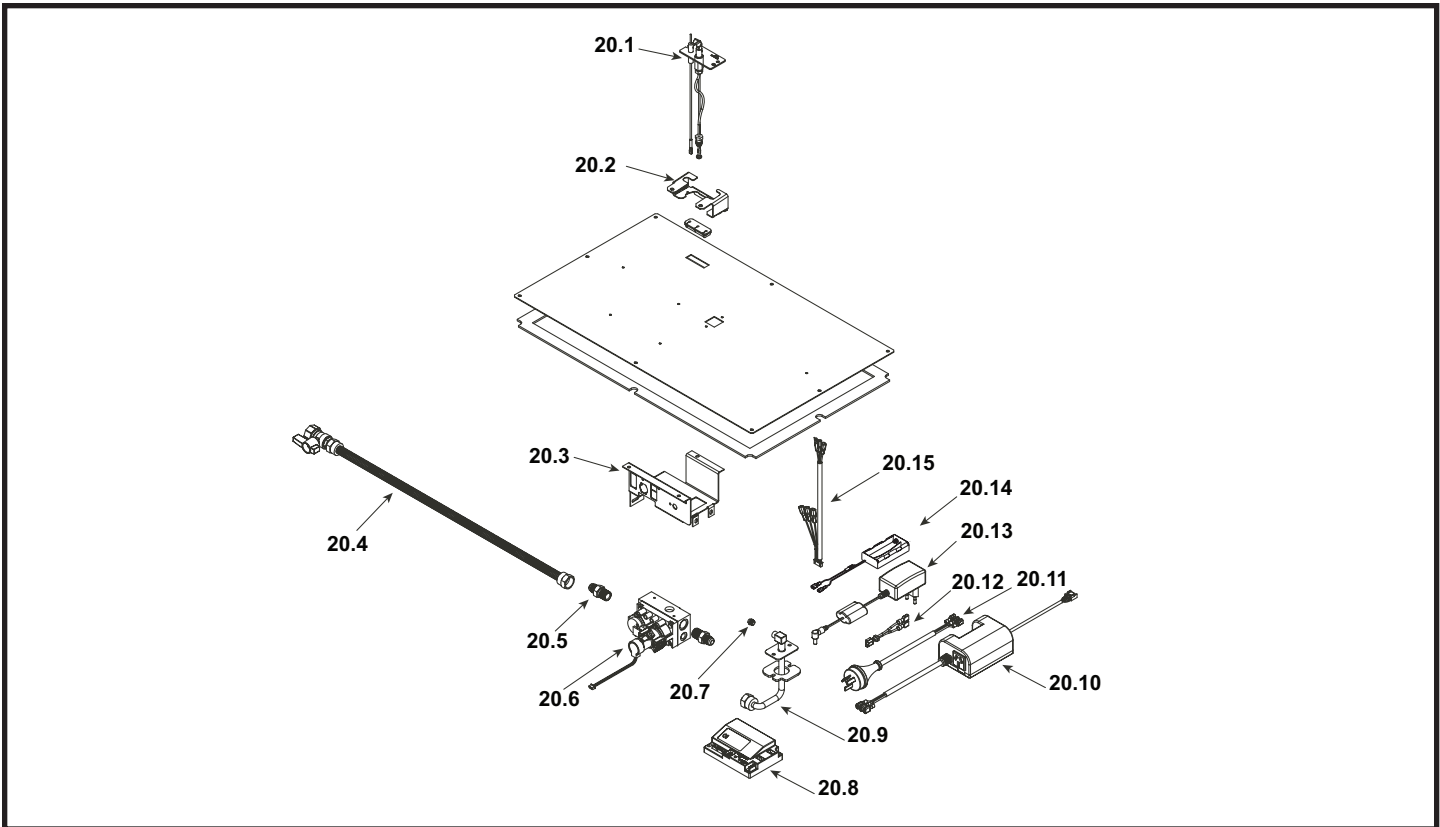

**IMPORTANT: THIS IS DATED INFORMATION.** When requesting service or replacement parts for your appliance please provide model number and serial number. All parts listed in this manual may be ordered from an authorized dealer.

ITEM	DESCRIPTION	COMMENTS	PART NUMBER
20.1	Pilot Assembly N		2198-012
	Pilot Assembly P		2198-013
20.2	Pilot Bracket		2078-108
20.3	Valve Bracket		2118-104
20.4	Flex Assembly, 24 in		2098-034
20.5	Male Connector	Pkg of 5	303-315/5
20.6	Valve N		2166-302
	Valve P		2166-303
20.7	Orifice N (#33C)		582-833
	Orifice P (#51C)		582-851
	Orifice B (#53C)		582-853
20.8	Module, Gray		2166-306
20.9	12" Flex Tube Assembly		383-302A
20.10	Aux300 CE		2166-340
20.11	Jumper Wire, (Fan to Aux))		2166-375
20.12	Jumper Wire		2187-198
20.13	DC Switching Adaptor		2166-369
20.14	Battery Pack**		4067-223
20.15	Wire Harness, 8K-1		2166-304

\*\*Fuse for battery pack can be sourced locally, not a warranty item. Specs are 500mA~10A 3/4" long

