



**Pryda's  
Specification Guide  
for Floor and Rafter  
Truss Systems**

April 2012





## Pryda Floor Truss System

<b>Introduction</b> .....	6
Pryda Longreach Trusses.....	6
Pryda Span Trusses.....	6
<b>Frequently Asked Questions and Answers</b> .....	7
<b>Product Benefits</b>	
Net Installed Cost Benefit.....	8
Design Benefits.....	9
Construction Benefits.....	10
<b>Design Considerations</b>	
General Information.....	11
Permanent Actions (Dead Loads).....	11
Imposed Actions (Live Loads).....	11
Computing Wall and Roof Loads on Floor Trusses.....	12
Guidance on Other Loads.....	12
<b>Factors Affecting Floor Performance</b>	
Truss Orientation.....	13
Flooring Material.....	13
Strong-Backs.....	13
Bearing.....	13
Supporting Beams.....	13
No Ceiling Underneath Trusses.....	13
<b>Serviceability</b> .....	14
<b>Fire and Sound Resistance</b> .....	14
<b>Durability</b>	
Sub-Floor Ventilation.....	14
Corrosion Protection.....	14
Protection of Exposed Cantilever Areas.....	14
<b>Detail</b>	
End Types.....	15
Internal Walls	
Internal Non Load-Bearing Walls – Over Floor Truss.....	19
Internal Non Load-Bearing Walls – Under Floor Truss.....	20
Internal Non Load-Bearing Bracing Walls – Under.....	20
Load Bearing Walls – Under Floor Truss.....	20
External Walls	
Fully Supported End Truss.....	21
End Truss Under Gable Roof.....	21
End Truss Carrying Roof Loads Over.....	21
Offset Load-Bearing Walls.....	21
Support of Concentrated Loads.....	21
Floor Openings.....	22
Beam Pocket Detail.....	22
Block Detail.....	22
Stairway Parallel to Trusses.....	23
Stairway Perpendicular to Trusses.....	23
Floor Set Down.....	24
Ducts for Mechanical Services.....	24
Cantilevers	
Internal Cantilever.....	25
External Cantilever (Balconies).....	25
Cantilevered Support Off-Set Walls.....	26
Outrigger Support of Off-Set Walls.....	26

Strong-Backs	
Size Beam Selection.....	27
Splice Detail.....	27
Non-Aligned Strong-Backs.....	28
Strong-Backs Not Required.....	28

<b>Stability</b>	
General.....	28
Wind Bracing.....	28
Lateral Bracing of Floor Trusses Chords.....	28
End Bracing.....	29
Bracing Walls Supported by Cantilever.....	29
Fixing at Supports.....	30
Face Fixing of Floor Trusses.....	30
<b>Installation</b> .....	31

## Pryda Rafter Truss System

<b>Introduction</b>	
Purlin Trusses.....	32
Rafter Trusses.....	32
<b>Product Benefits</b> .....	32
<b>Design Considerations</b>	
Design Loads	
Permanent Actions (Dead Loads).....	33
Imposed Actions (Live Loads).....	33
Wind Actions (Wind Loads).....	33
Ducts for Mechanical Services.....	33
<b>Factors Affecting Performance</b>	
Deflection Limits.....	34
Special Loading Conditions.....	34
<b>Stability</b>	
Top Chord Bracing.....	34
Bottom Chord Bracing.....	34
Cantilever Bracing.....	34
Fixing to Supports.....	34
<b>Detail</b>	
End Configurations.....	35

## Appendices:

<b>A - Producer Statement</b> .....	36
<b>B - Typical Layout</b> .....	38
<b>C - Detailers Guide / Check List</b> .....	39
<b>D - Design Request Form</b> .....	40
<b>E - Floor Truss Span Tables</b>	
Normal Domestic Loads.....	41
Commercial Office Loads.....	42
Important Notes about Span Tables.....	42
<b>F - Rafter or Purlin Truss Span Tables</b> .....	43
Normal Domestic Loads.....	43
Commercial Building Loads.....	43
<b>G - Impact of Higher Permanent Loads</b> .....	44

# PRYDA FLOOR TRUSS SYSTEM

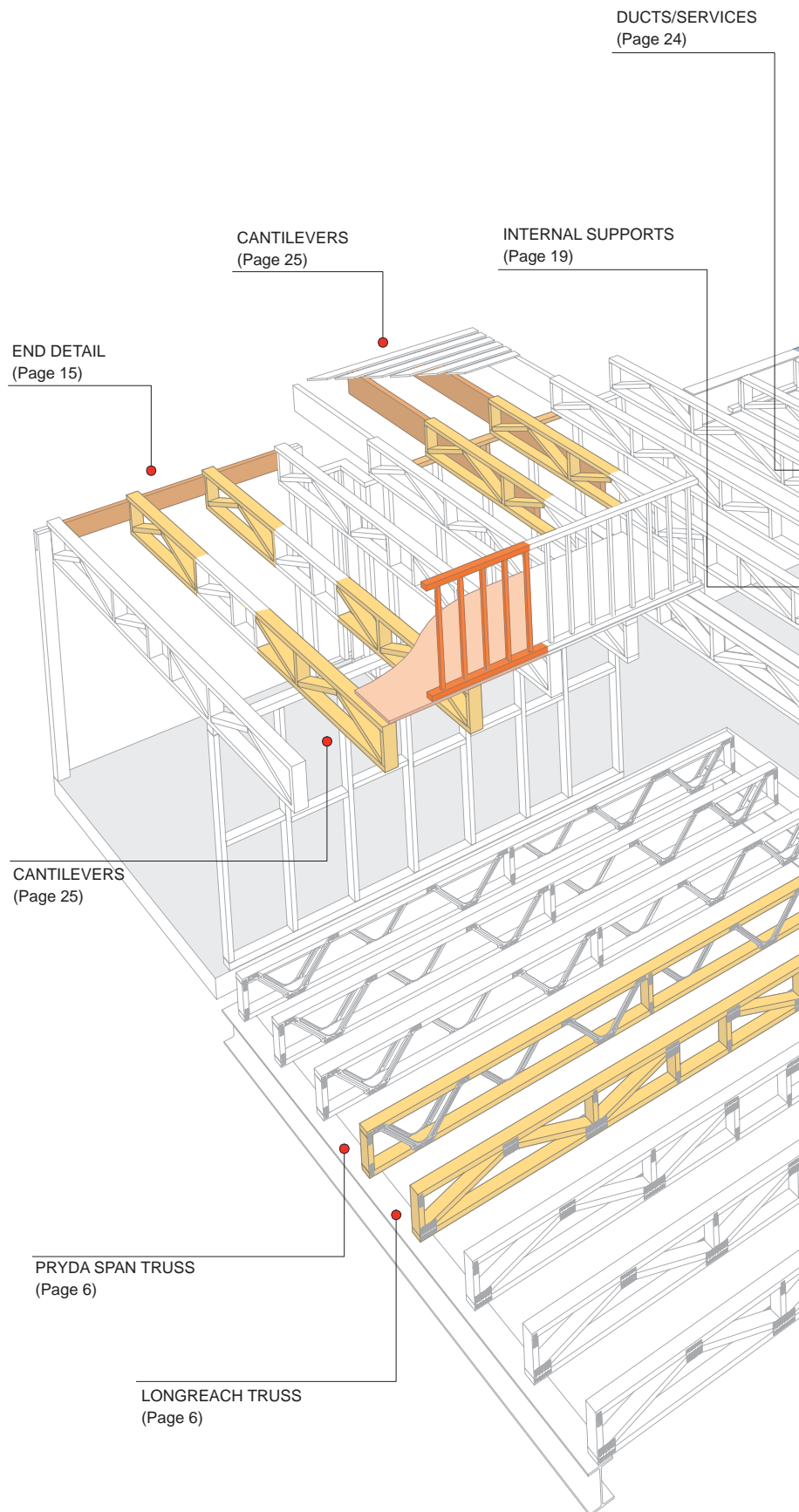

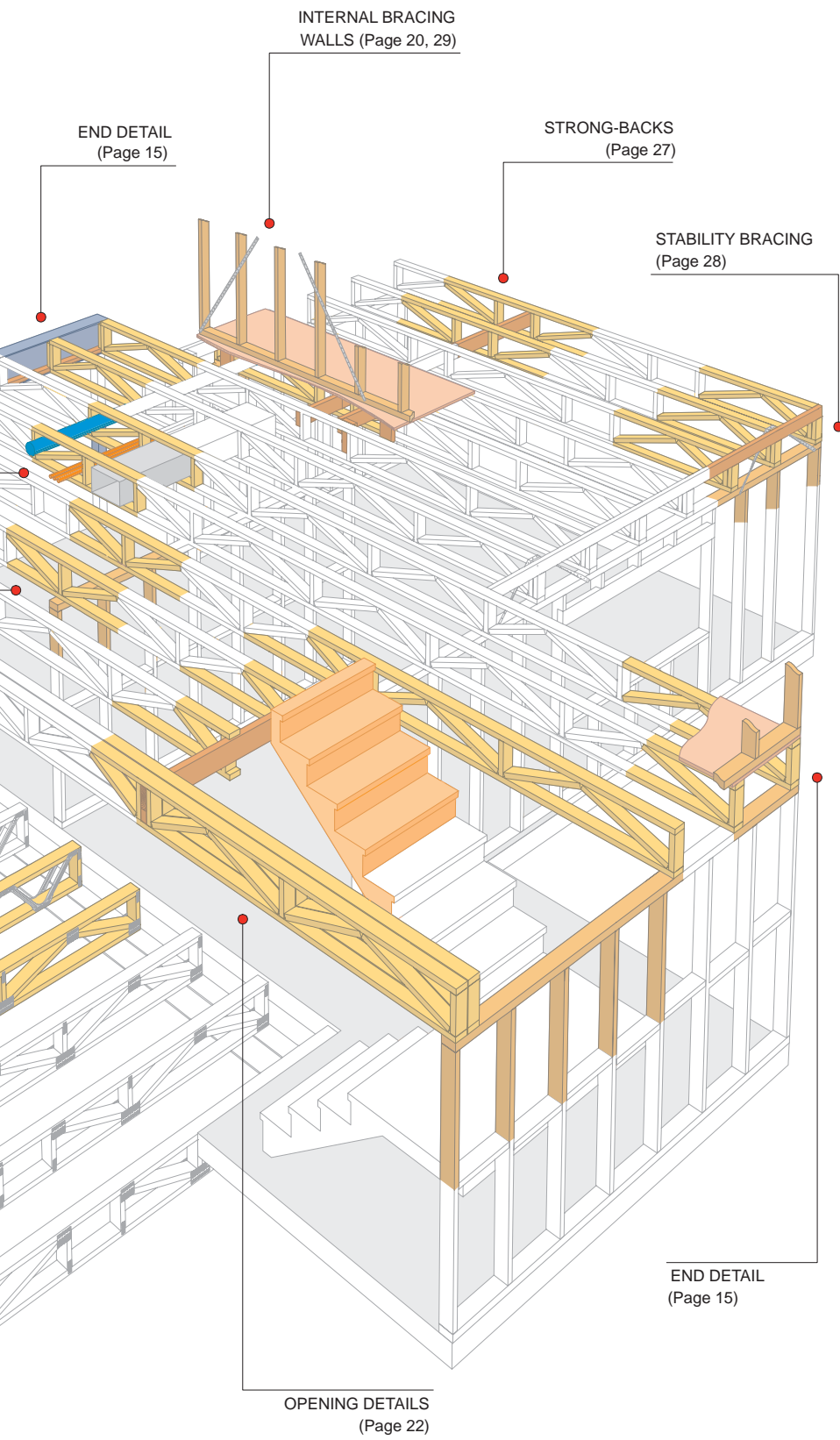

## INTRODUCTION

Pryda Floor Truss Systems are a complete structural system for timber floors made up of flooring material, floor trusses, Strong-Backs, connections and bracing. They have been proven over many years and provide occupiers with floors that have an excellent and predictably reliable performance.

The timber for these trusses is on flat, which provides a stable platform during installation and minimizes the overall depth required. All trusses use commonly available timber and most floor trusses in Australia are made from 70mm or 90mm dry timber.

There are two different types of web systems for these trusses. Both have timber chords but Pryda Longreach uses all-timber webs, while Pryda Span uses metal webs for the diagonals and timber webs for the verticals.

Both systems of Pryda floor trusses are generally made to order by licensed fabricators. While there are standard end details that allow trusses to be trimmed on site, this practice is not common. This is not only because all trusses are designed for an exact span for economic reasons, but the interaction between the true span of the trusses and the flooring should be considered for proper dynamic performance assessment.

### Pryda Longreach Trusses

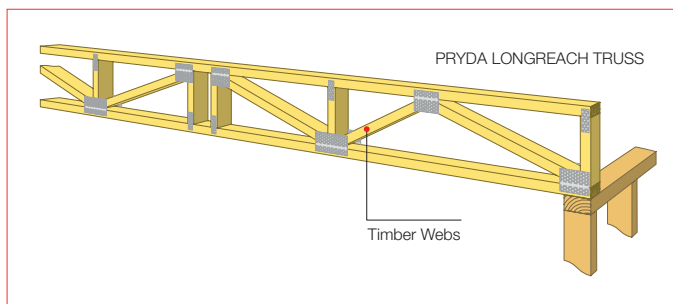

Longreach trusses are a premium performance product using nail-plated, all-timber components of any depth, but typically 300mm deep for residential floors and 400mm deep for commercial floors.

Pryda Longreach trusses are referenced as FT200, FT250, FT300, FT350 and FT400, where 'FT' means Floor Truss, and '200' is the nominal overall depth (mm). The actual depth dimensions are in nominal size steps, or may be individually specified as required for the particular project.

Pryda Longreach can be designed for all common floor loads, including commercial loadings up to 5 kPa or point loads up to 6.7 kN. These trusses are slightly heavier than Pryda Span trusses and being all-timber generally have a stiffer performance as they can dissipate floor vibrations very well, and the nail-plates connecting the webs and chords are quite substantial.

### Pryda Span Trusses

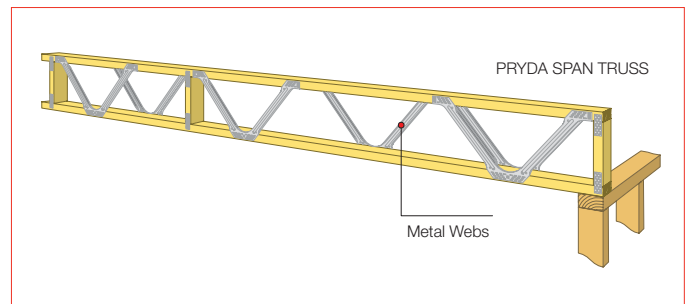

Pryda Span trusses have metal diagonal webs for light weight and economy. They are ideal for shallower trusses where there is more clearance room to accommodate the plumbing than with timber webs and for trusses where the chord design has some reserve capacity, as is often the case. In some instances, a few diagonal metal webs may have to be replaced by timber webs in these trusses, as load or geometry considerations dictate.

Webs may be on both faces of the truss or just on alternate faces, and in the latter case this allows for the webs to overlap.

Pryda Span trusses are referenced as PS25, PS30, and PS40, where 'PS' means Pryda Span, and '30' is the nominal overall depth (cm). The overall depths are nominally 250, 300 and 400mm deep. The actual depth dimensions are in nominal size steps according to the metal web used, and if required, the specific depth should be obtained from the Pryda licensed fabricator.

Pryda Span is manufactured using light gauge metal webs and are lighter than Longreach, but this is considered during the design process. The metal web system can be very cost-effective, especially if the truss chords have reserve capacity, as is often the case. The nail plates and Pryda Span metal webs are made to exacting standards from G2 grade steel with a minimum of Z275 galvanised coating.

## FREQUENTLY ASKED QUESTIONS & ANSWERS

### Q. What is the market point of difference for this product?

**A.** Pryda floor and rafter trusses are **customised** for each job, including required stiffness, depth, timber grades and span. It will be computer designed for optimal performance, cost and installation efficiency while minimizing waste.

The **open web design** ensures services are easily installed. There is no drilling or notching, saving time on site.

**Extra long spans** and large cantilevers can be provided, with the ability to support high loads. Spans up to 7.1m at 400mm depth can be achieved.

Significant **design improvement with minimal cost increases** can be achieved with the Pryda Longreach (timber web) truss, by simply increasing its depth.

There is a large selection of **end support types** for quick and easy installation. Pryda floor and rafter trusses arrive on site manufactured to size and ready to install, eliminating the need to trim on site.

**Set down or recess sections** can be designed and prefabricated into the floor truss. This results in significant labour savings when it comes to laying floor coverings on balconies or fixtures and tiles in the bathroom.

### Q. What is it made from and is it "green"?

**A.** Pryda produces two types of floor and rafter truss products, Pryda Longreach, which contains timber webs joined with steel nailplates and Pryda Span which is manufactured with metal webs.

Both products are manufactured using timber top and bottom chords. On average the **timber component of the floor truss makes up 70% of the cost** of the product.

Timber frame buildings are now being designed to meet low energy construction standards as timber has a high standard of **thermal comfort** while consuming minimal non-renewable energy.

A principal objective for responsible design of environmentally friendly timber construction is to minimise life cycle energy consumption. Timber in lightweight construction is a **superior material** compared to manufactured material such as steel, concrete and masonry as it uses a comparatively small amount of non-renewable energy in its extraction and manufacture.

**Timber maximises the efficiency of insulation** materials because wood never gets cold or dissipates heat, therefore less energy is required to maintain warmth in a building, and the less energy used, the less damage to the environment.

Today timber is available with a variety of popular and very cost effective treatments that can make it an extremely durable and termite resistant building material.

The metal webs used in Pryda Span are manufactured from Bluescope Steel G2 grade with Z275 galvanised coating.

The Pryda Claw® nailplates used for joining of timber in the construction of both Pryda Longreach and Pryda Span floor and rafter trusses are manufactured from Bluescope Steel G300 grade with Z275 galvanised coating.

It should be noted that steel is 100% recyclable and by volume is the most recycled material in the world.

### Q. Is it expensive?

**A.** If you are comparing flooring systems' cost on a per lineal metre basis, there are less expensive alternatives. However you need to consider the **"net installed cost"**. Pryda floor and rafter trusses can provide both installation and design savings.

As stated earlier, each job is **customised** to ensure the most cost and design efficient outcome. In addition significant design improvements can be made by simply increasing its depth at minimal cost increases.

Floor trusses can **span further** than alternative flooring systems, which may result in savings in additional support structures. E.g. Internal load bearing walls, steel beams.

### Q. Is it easy and quick to install?

**A.** On site, the Pryda floor and rafter truss products are generally **quicker to install** than other types of joists or rafters. As the truss **end support connections** are all prefabricated there is no cutting or complicated fitting required, which will speed-up installation and minimize mistakes. There are 20 end support type options available.

The **open-web** design of the product eliminates potentially damaging practices such as cutting out sections for services or drilling large holes. This ease of access for installing services including plumbing, heating ducts, electrical wiring and electronic data cabling is a major benefit to builders.

### Q. What accreditation does the product have?

**A.** **Pryda Build software** is used by licensed Pryda truss and frame fabricators to produce designs and manufacturing specifications for Pryda floor trusses.

Pryda Build has been **independently assessed** by professional consulting structural engineers for compliance with the Building Code of Australia, BCA 2010, and its referenced documents.

Pryda has also demonstrated compliance with the requirements set out in the ABCB Handbook "The Use of Structural Software for Building Design Approval" (2007).

All licensed Pryda fabricators are trained by Pryda in the use of Pryda Build. Users are issued with a Certificate of Training if they have demonstrated an acceptable understanding of the features presented during the course. Evidence of this training to any fabricator using Pryda Build may be obtained on request.

In addition the following reports are available and they can each be produced by a licensed Pryda fabricator:

- **Producer Statement Report** – a statement of design compliance for the whole job with overall and nominal design criteria, and BCA referenced documents.
- **Plan Layout** - showing the roof and all trusses laid out; all bracing (input by users); special notes for installation; all truss-to-truss connections.
- **Detail Sheet** – a drawing of each truss with all relevant design parameters associated with that particular truss.
- **Design Report (summary)** – all general loads; all applied distributed loads; truss serviceability displacements for major loads; support reactions; critical member timber designs details; bearing requirements; and nailplate design details at critical joints.
- **Design Report (detailed)** – as for the summary report, plus the results of the analysis for the 4 most critical combined load cases; all timber member designs; all nailplate joint designs.

### Q. Where can I get it?

**A.** Pryda floor trusses are available through licensed Pryda truss and frame fabricators. You can locate your preferred fabricator via our website, [www.pryda.com.au](http://www.pryda.com.au) or by calling 1800 810 741.

## PRODUCT BENEFITS

Pryda Floor Truss Systems offer many benefits to the designer, the builder and the building owner in providing a reliable high performance system for both domestic and light commercial construction. The use of the Pryda Floor Truss System results in a very cost effective, high quality product that is sufficiently flexible to accommodate the most complex of building requirements.

### Net installed cost benefit

The Pryda fully engineered open-web timber floor truss systems with timber webs (Pryda Longreach) or metal webs (Pryda Span) have many advantages that result in a lower net installed cost compared to other systems that are available. In some instances there may be a material cost increase by using Pryda floor trusses over alternative flooring systems. However when it comes to installing the product Pryda floor trusses can provide significant labour savings. In addition, floor trusses have some considerable design advantages that could result in reducing the need for a large amount of costly structural support construction. E.g. Long spans may reduce the need for internal load bearing walls.

Go to the Pryda website [www.pryda.com.au](http://www.pryda.com.au) to view the St. Clair Park Village case study. There was a 6% increase in material costs by using Pryda Longreach floor trusses over solid joists. Framing time was reduced by 2 weeks and the labour saving was 2.5 times larger than the material cost increase.

Examples of these advantages are as follows and should be considered in the assessment of the overall cost of the flooring system:

### Design cost savings

- **Cost Efficient Design.** Each floor truss is customised for the job, including required stiffness, depth, timber grades and span. It will be computer designed for optimal performance and cost and installation efficiency while minimizing waste.
- **Significant Design Improvement With Minimal Cost Increases.** Span capacity and stiffness can be significantly enhanced by simply increasing the depth of the Pryda Longreach floor truss. Due to the timber web design of the floor trusses, the increase in depth is at a minimal cost.
- **Greater Design Flexibility.** Extra long spans and large cantilevers can be provided, with the ability to support high loads. Spans up to 7.1 metres at 400mm depth using MGP12 pine can be achieved. This results in the following design and cost benefits:
  - The long spans can potentially eliminate the need for some interior support walls and beams, giving more scope to architects and designers thus reducing the cost of the support structure.
  - Large spans within restricted height applications can be achieved with Pryda floor trusses. In some cases the use of floor trusses may eliminate the need to use costly steel beams.
  - Ideal for sloping blocks. In some instances floor trusses could be used to eliminate or reduce the excavation costs associated with sloping blocks.

Long cantilevers make floor trusses ideal for sloping blocks

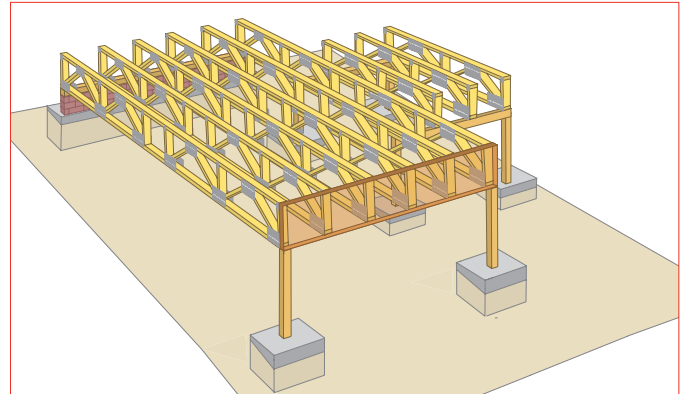

### Labour cost savings

- **Set Down or Recess sections.** The ability to design and manufacture set down sections into the floor trusses provides significant labour savings in the following situations:
  - In cantilever and balcony areas where the provision of adequate flashing and accommodation of different floor covering material thicknesses is critical.

Example of set down section for a balcony

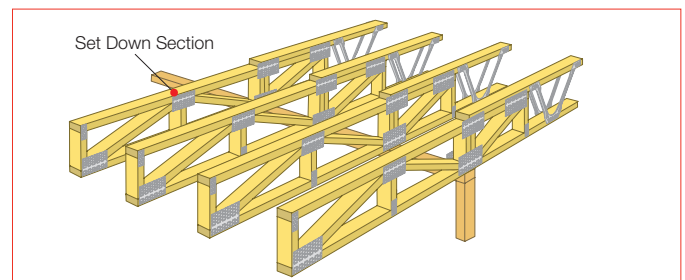

- Bathrooms, toilets and other wet areas may also require the floor surface to be set down. This will provide significant labour savings when other trades start installing bathroom fixtures, fittings and tiling.

Example of an internal set down area

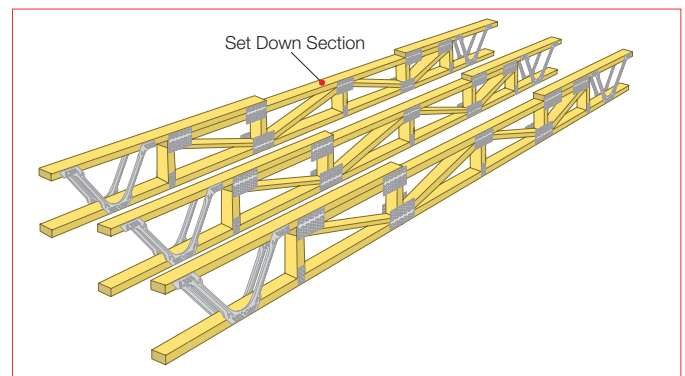



- **No Cutting, Drilling or Notching.** The open webs and voids designed to allow easy fixing of electrical, plumbing, ducts and energy services. There is no need for drilling or notching, saving time on site.

Example of voids and open webs accommodating services

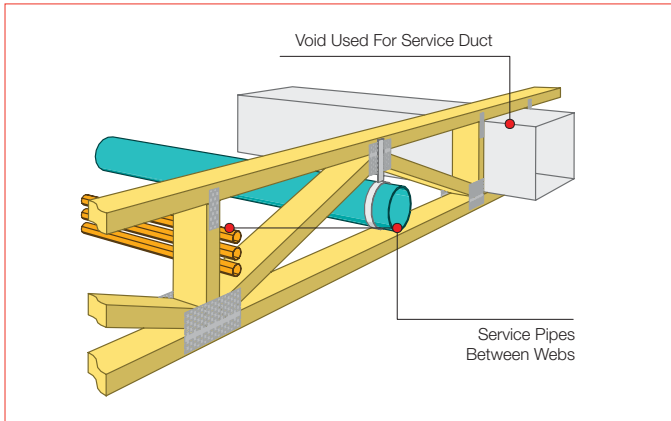

- **Quick Installation.** A large selection of end support types for quick and easy installation. Pryda floor trusses arrive on site manufactured to size and ready to install, eliminating the need to trim on site. There is no material or labour wastage. Pryda floor trusses are designed and manufactured with end types for fast, secure fixing to steel, concrete, masonry or timber. Go to page 15 or the Pryda website [www.pryda.com.au](http://www.pryda.com.au) to view the available options.

Example of end type designed for fixing to masonry

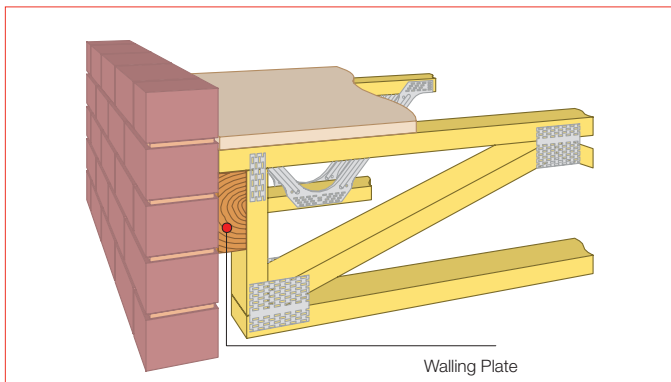

Example of end type designed for fixing to steel beams

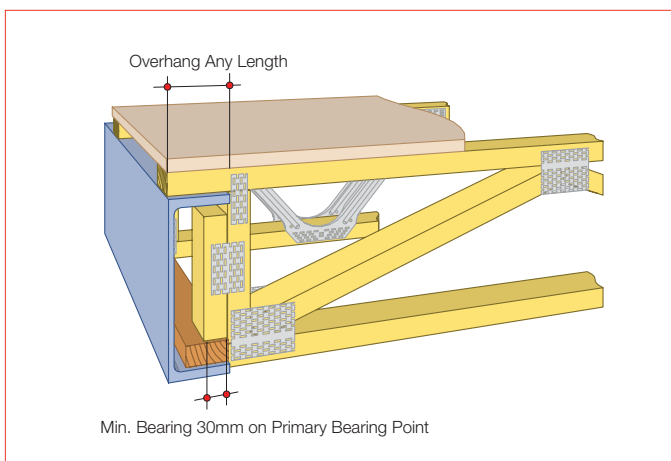

In addition to providing net installed cost savings there are numerous design and construction benefits of Pryda floor truss systems, they are as follows:

**Design Benefits**

- **Assured Performance.** Pryda floor and rafter truss systems have been used with outstanding results for over 15 years by designers and builders.
- **Design Versatility.** The long span capacity - up to 8 metres or more - offers functional design freedom and can eliminate the need for interior support walls and beams.
- **Depths to Suit.** Wide range of standard depths available - from 200 to 450mm - or can be manufactured specifically for a particular project.
- **Limited Space.** Designs can accommodate large spans in restricted height applications.
- **Cost Effective.** Timber grade in chords is selected to suit the design requirements of each individual project to provide the most cost effective system.
- **Larger Spans at Low Cost.** With all-timber trusses (Pryda Longreach) the span capacity increases significantly as the truss depth increases - at little extra cost.
- **Commercial Applications.** Pryda floor trusses not only accommodate domestic loads but may also be designed for light commercial applications including offices, schools, hospitals and function areas.
- **Designed to Order.** Stiffness required, depth, timber grades and sizes can be varied to suit any individual job requirements. Computer designed for optimal performance efficiency and lowest material cost.
- **Wide Range of End Supports.** Standard end support types suit structural connections to steel, concrete, masonry or timber.
- **Extra Stiffness in Floors.** Stiffer than other floor systems with established dynamic limits to ensure rigidity and to overcome springiness and bounce. Designed to provide a floor that feels and acts "rock-solid".
- **Accommodates Large Ducts.** Large rectangular ducts to 500mm wide can fit within the standard design and special duct routing within rows of trusses can be incorporated.
- **Dimensionally Stable.** Fully kiln-dried timber ensures stability, free from movement due to shrinkage.
- **Efficient Use of Timber.** More efficient use of natural resources than solid timber joists.
- **CAD Compatible.** Standard data and design details available on CAD.

### Construction Benefits

- **Easy to Install.** Truss end support connections are pre-manufactured to fit. No cutting or notching will minimise the possibility of mistakes.
- **Ease of Access.** Flexible ducting, electrical wiring and electronic data cabling can be easily run between the truss webs.
- **No Cutting Holes.** Simplifies the work of following trades. Plumbing, ventilation ducts and conduits can be simply attached to the webs or chords without any cutting or drilling holes.
- **Faster Installation.** Quicker installation times provide the opportunity to reduce construction costs.
- **Stable Platform During Construction.** The wide chord flanges are more stable for tradesmen moving around the elevated areas on a job.
- **Lightweight.** Trusses are much lighter than solid timber sections. Much easier to handle and lift on site.
- **Floor Set Down Feature.** A section of Longreach floor trusses can be manufactured with a reduced depth to accommodate tiled wet areas and other floor coverings in bathrooms and on balconies.
- **Consistent Depth.** Longreach floor trusses can be manufactured to the same depth for the entire project to eliminate uneven ceiling levels at little extra cost - regardless of the variations in spans.
- **Robust Construction.** More robust than other prefabricated systems, and more able to resist the effects of mishandling. Pryda Span metal web design has a patented deep V profile incorporating stiffeners for improved performance and resistance to damage during handling on site.

## DESIGN CONSIDERATIONS

### General Information

Floor trusses are to be designed for a combination of permanent actions (dead loads) and imposed actions (live loads) in accordance with the loading standards referenced in the Building Code of Australia (BCA)

### Permanent Actions (Dead Loads)

Permanent actions are defined in AS/NZS 1170.1:2002 to include, but not limited to, actions of the following items:

- (i) *Weight of floor systems*: This includes flooring material, floor coverings, self weight of supporting members etc. Eg: Tiled floors apply larger loads than carpeted floors
- (ii) *Weight of walls*: eg: external load bearing walls or heavy internal tiled or acoustic walls need special attention.
- (iii) *Weight of roof*: any loads transferred down from the roof to the floor should be considered.
- (iv) *Fixtures and fittings*: spa baths, kitchen benchtops etc are capable of influencing design.
- (v) *Storage*: loads from book shelves, billiard tables etc which are likely to be in place for long periods should be treated as permanent in nature.

**Table 1 – Typical Floor Construction Weights**

Mass of Floor (kg/m <sup>2</sup> )	Description of Floor Constructions
25	Standard floor up to 22mm particleboard with carpet or vinyl floor covering and no ceiling
40	Standard floor up to 22mm particleboard with carpet or vinyl floor covering with 10mm particleboard ceiling (Typical mass given in AS 1684)
50	18mm fibrecement sheet (wet areas) with lightweight floor covering with 10mm plasterboard ceiling
75	75mm Hebel floor with carpet or vinyl floor covering with 10mm plasterboard ceiling
85	18mm fibrecement sheet (wet areas) + ceramic tiles on adhesive with 10mm plasterboard ceiling
110	18mm fibrecement sheet (wet areas) + ceramic tiles on 40mm mortar bed with 10mm plasterboard ceiling

**Table 2 – Typical Wall Construction Weights**

Mass of Wall (kg/m <sup>2</sup> )	Description of Wall Construction
15	As used in AS 1684 – typical for external walls with cladding on one side only
25	Typical lightweight internal walls with 10mm plasterboard on each side or a combination of plasterboard and 6mm fibre-cement sheet
45	Heavyweight internal sound proof walls with 2 layers of 13mm Soundcheck plasterboard on each face
60	Heavy-weight internal sound proof walls with 2 layers of 16mm Fyrchek plasterboard on each face
70	Heavyweight external walls with Hebel Power Panel on external face and 10mm plasterboard on internal

**Table 3 – Typical Roof Construction Weights**

Mass of Roof (kg/m <sup>2</sup> )	Description of Roof Construction
10	Steel sheet roofing 0.48mm thick with battens
20	Metal sheet tiles or 0.55mm thick steel sheet roofing. 12mm softwood ceiling lining, sarking and lightweight insulation
30	Steel sheet roofing 0.75mm thick. 13mm plasterboard ceiling, roof and ceiling battens, sarking and lightweight insulation
40	Steel sheet roofing 0.75mm thick, high density fibre-cement ceiling, roof and ceiling battens, sarking and lightweight insulation
60	Terracotta or concrete tiles and roof battens with no ceiling
75	Terracotta or concrete tiles, roofing and ceiling battens, 10mm plasterboard ceiling, sarking and insulation
90	Terracotta or concrete tiles, roofing and ceiling battens, 19mm hardwood ceiling, sarking and insulation

### Imposed Actions (Live Loads)

Imposed actions are the transient loads that are placed on the floor due to people, furniture etc. These loads are an estimation of the temporary occupation and the associated use of the space that the floor supports. Typically trusses are designed for a uniformly distributed live load and a 'moving' concentrated load. These two loads are considered separately – whichever produces the most adverse effect.

**Table 4 - Typical Imposed Actions on Houses**

Load Type	General areas	Balcony
Uniformly distributed load	1.5 kPa	2.0 kPa
Concentrated point load	1.8kN	1.8kN

*Note to Engineers:* If the floor trusses are intended to carry loads other than houses, then the relevant information should be passed on to the truss manufacturer prior to the design process. Read AS/NZS 1170.2: 2002 for complete details of imposed actions. Below is an extract from this code:

**Table 5 – Typical Imposed Actions on Commercial Buildings**

Floor Application	Uniformly Distributed Load kPa	Point Load kN
Assembly areas	3.0 - 5.0	2.7 - 3.6
Public corridors and spaces	4.0 - 5.0	4.5
Stages	7.5	4.5
Offices	3.0	4.5
General storage	2.4/m height	7.0
Drill rooms and halls	5.0	9.0

**Computing Wall and Roof Loads on Floor Trusses**

This section provides guidance on how to determine additional loads applied on floor trusses from internal and load-bearing external walls.

*Definitions:*

- Mr = Mass of Roof (kg/m<sup>2</sup>) – Refer Table 3
- Mw = Mass of Wall (kg/m<sup>2</sup>) – Refer Table 2
- RLW = Roof Load Width (m)
- FLW = Floor Load Width (m)
- Hw = Wall Height (m)

Note: The floor load width (FLW) is usually taken as the spacing of floor trusses. However, if the spacing is irregular, then FLW is the sum of half-spacings from the truss in consideration to the respective adjacent trusses.

**Loads from Internal Non Load-Bearing Walls**

A knowledge of the floor load width (FLW), the mass of wall (refer Table 2) and the wall height is required to determine the point load applied on the floor truss.

*Dead Load (P) in kN:*

$$P = M_w * H_w * FLW / 100$$

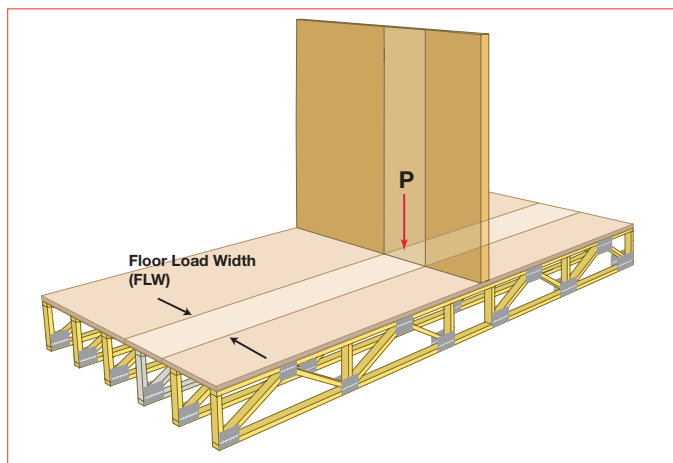

Internal non load-bearing wall load on floor truss

**Loads from External Load-Bearing Walls**

External load-bearing walls supported by floor trusses are becoming increasingly common in today's designs. The ability for floor trusses to carry load-bearing walls has enabled designers to delete steel beams from the floor frame and help achieve economical designs.

In addition to the FLW, wall weight and wall height, the roof load width (RLW) and the roof mass are also required to determine the point load on the floor truss.

The RLW is computed similar to AS1684, using half truss span + overhang, and dividing the sum by the cosine of the roof pitch.

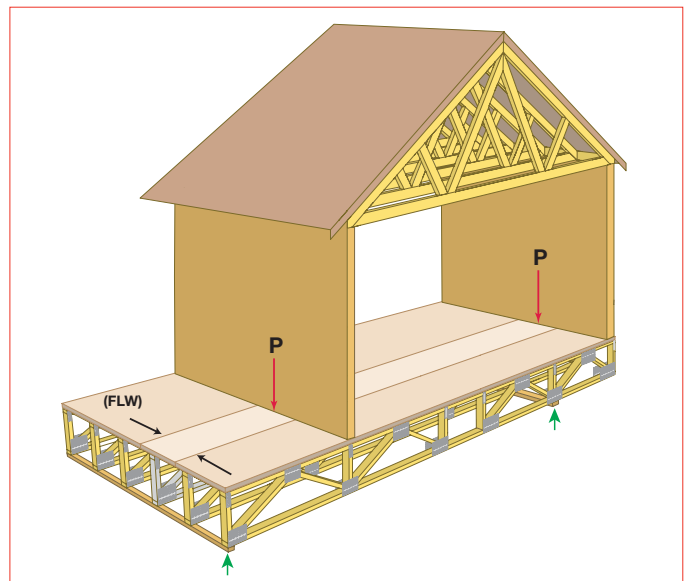

External loadbearing wall loads on floor truss

*Dead Load (P) in kN:*

$$P = (M_r * RLW + M_w * H_w) * FLW / 100$$

*Roof Load*
*Wall Load*

Any concentrated wall studs (supporting girder truss) or jamb studs should be treated separately, and specially designed floor trusses may be provided at these specific locations.

**Guidance on Other Loads**

**Spa Baths**

Modern spas are generally made out of acrylic or metal and come in different shapes having light-weight shells. However, spas that are made out of cast iron, stone etc and those needing grout bedding are significantly heavier and therefore require special attention.

Licensed Pryda fabricators have the facility to apply a load area on the floor layout to simulate loadings from spa baths using Pryda's proprietary software, *Pryda Build i*. For eg: Acrylic or metal spa baths (without grout bedding) would typically apply a permanent load of 40 kg/sqm and an imposed load of 2.0 kPa over the load area. Note: The base area of the spa would determine the load area.

**Other Heavy Loads**

Where special load cases are to be applied to the floor trusses such as heavy ceramic tiles etc, adopt design charts provided in the Appendix.

For other heavy furniture items like billiard tables, grand pianos etc, seek advice from a Pryda Design Office.

## FACTORS AFFECTING FLOOR PERFORMANCE

Floor liveliness, or bounce, has been an intermittent issue over the years with lightweight residential floors - for all forms of timber and steel construction. To eliminate these problems, Pryda Floor Systems are designed to stringent dynamic performance criteria.

The floor truss is only one component that can affect the floor performance. On-site conditions are always important and proper attention to detail must be taken at the time of installation.

### Truss Orientation

To ensure the floor performance it is important that all trusses are installed as designed. That is in the correct location, orientation and the right way up. The floor truss layout provided by the authorized Pryda fabricator should be used to position all trusses and the diagrams below used to ensure the trusses are installed the correct way up.

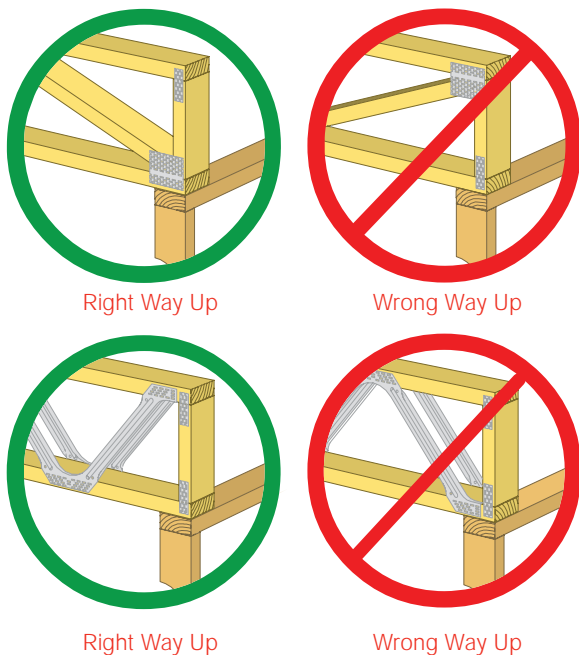

### Flooring Material

The flooring material has a significant effect on the perceived bounciness of a floor. It has the ability to spread human impact loads depending on the material and the thickness. Plywood acts differently to particleboard, and T&G acts differently to both. A simple way to improve floor performance is to select flooring that is stiffer (e.g. thicker) than the minimum for your chosen application.

### Strong-Backs

These are timber members, e.g. 140 x 35mm running at right angles to the trusses. There is generally one row down the centre, but there could be more with larger spans. Their main function is to help the flooring spread footfall impacts to adjacent trusses. They become of greater importance as the spans and loads become larger. It is important that Strong-Backs be properly attached to the truss vertical webs as detailed, as poor fixing techniques, such as having large gaps between the Strong-Back and the web, can reduce the Strong-Back effectiveness considerably.

### Bearing

Trusses must bear directly on their supports and not be held above them by the flooring. This may sound odd, but where the support top plate is not level, and the flooring is nailed to the truss top chord, the flooring itself can lift the lower truss(es) by a few millimetres and this considerably worsens the perception of floor bounce. This situation is difficult to observe during the early stages of construction and in any instance of potential floor performance complaint it should be checked using a piece of card to see if there are any gaps between the trusses and their supports.

It is important that floor trusses bear over the support wall plate or beam with a minimum of 30mm for residential floors and 40mm for commercial floors. This requirement is implemented to ensure that localised crushing of the top plate or bottom chord does not occur. It also encourages suitable load transference between upper load-bearing wall frames and lower wall frames.

### Supporting Beams

If any floor system is supported on beams — e.g. steel or timber lintels/beams— the amount of floor bounce in that area can become unacceptable if it is not properly assessed at design time. The dynamics of any supporting beam and the dynamics of the truss must be considered simultaneously as they interact with each other. Each can be satisfactory in its own right, but not satisfactory in combination.

### No Ceiling Underneath Trusses

If there is no ceiling fixed directly underneath the trusses, install 90 x 35 F5 (on flat) lateral ties to the bottom chord, located approximately at the third points of the span. This will prevent one type of undesirable dynamic response which is otherwise normally prevented by the ceiling (if fixed directly to the truss bottom chords) or ceiling battens.

## SERVICEABILITY

Serviceability is an important consideration in floor truss design, and is often acceptance of a floor system is dictated by its performance under serviceability conditions.

Pryda floor trusses are designed for both deflection and dynamic criteria. The deflection limits are based on the recommendations given in AS1684.1 and those suggested in Table C1 of AS/NZS 1170.0:2002.

As part of the Dynamic performance, to ensure floor trusses are acceptable with regard to 'springiness' or 'bounce', additional criteria are adopted, apart from the ones suggested in the above codes. The natural frequency of the floor system (assuming rigid supports) is determined, and the users of Pryda's proprietary software have the option of nominating three levels of dynamic performance based on the frequencies – Enhanced (minimum 10 Hz), Normal (8 Hz) and Minimum (7 Hz)

**Note:** *The dynamics of a flooring system are characterised by the perceived frequency of vibration in the floor under a specific load. The rigidity of the supporting structure can have a significant effect on the dynamic performance of the floor system. For example, floor trusses supported by rigid walls will seem to exhibit less bounce than the same trusses supported by flexible beams that allow some level of support movement.*

It is the responsibility of the building designer or engineer carrying out the design of floor beams to consider the effect of them on dynamic performance.

## FIRE AND SOUND RESISTANCE

Pryda floor trusses may be used in fire or sound rated construction, in combination with cladding material that is rated to fulfil its function.

Fire resistance levels are normally referred to as FRL and are expressed in minutes as 60/60/60 (or similar) to reflect the structural adequacy, integrity and insulation respectively.

Sound resistance levels are given in two forms – airborne sound and impact sound. The former is expressed as  $R_w$  (weighted sound reduction index) and a value of  $R_w$  50 is typically applied to floors and walls – the higher the number, the better the performance is. The latter is expressed as  $L_{n,w}$  (weighted normalised impact sound pressure level). A value of 62  $L_{n,w}$  is common – the lower the number, the better the performance is.

These fire and sound resistance levels for classes 2, 3 and 9c buildings are given in the Building Code of Australia (BCA). Some manufacturers of cladding material, eg: CSR Gyprock, Boral Plasterboard, Lafarge Plasterboard etc, have provided technical manuals that illustrate construction technique and assemblies that comply with the BCA "Deem to Comply" provisions.

Generic details of construction and typical assemblies incorporating floor trusses may be found in Technical Manual by Forest & Wood Products Australia (FWPA) - "Timber-framed construction for multi-residential buildings classes 2, 3 and 9c.

## DURABILITY

### Sub-Floor Ventilation

Adherence to the recommendations of the BCA relating to sub-floor ventilation is critical to ensure the long-term serviceability of floor trusses that form part of the sub-floor. Clause 3.4.1.2 of the BCA requires that the sub-floor space must be: (a) cleared of all building debris & vegetation; and (b) be cross-ventilated by means of openings; and (c) contain no dead air spaces; and (d) ventilation openings are evenly distributed; and (e) be adequately graded to ensure proper surface water drainage.

### Corrosion Protection

Pryda metal webs (Pryda Span floor trusses), and nailplates (Longreach floor trusses) are manufactured using Z275 light-gauge steel, having zinc coating of 275 gsm (total weight). This protection is adequate only for INTERNAL applications in most corrosion environments, except areas that are classified as heavy industrial or those subject to high humidity (eg: enclosed swimming pools) etc. Under these circumstances, seek advice from experts as special protection will be required. *Note: INTERNAL areas are those within the building envelope that are kept permanently dry.*

In areas outside the building envelope that are exposed to repeated wetting (EXTERNAL areas), Pryda's stainless steel products or equivalent should be considered. Some sheltered areas like open sub-floors with no perimeter walls may sustain worse corrosion than fully exposed conditions, and therefore is prudent to treat this as an EXTERNAL situation. Accordingly nailplates or metal webs used in floor trusses within a 'open' sub-floor should have additional corrosion protection.

Some alternatives to stainless steel include hot dip galvanised or powder coated steel, which are not supplied by Pryda. For more detailed information, read Pryda's Technical Update on *Corrosion Resistance of Pryda Products* or contact a Pryda office.

### Protection of Exposed Cantilever Areas

Cantilevered areas that are exposed to the elements need special attention. An effective and durable barrier must be provided at the outside of external walls to completely prevent moisture penetration into the building.

All timber exposed to the weather, including timber covered with decking etc must be treated to H3 level or higher. Refer section on Cantilevers (page 25) for further details on this subject.

## DETAIL

### End Types

Pryda floor trusses have the advantage of adapting to a range of different on-site support conditions. The dimensions of the 12 standard end types can vary to meet most detailing requirements. The joint details shown in this manual are intended as a guide only. Variations to these may be required and should be verified.

The Pryda software includes many End Type detail drawings. Pryda highly recommends that designers select the relevant drawing(s) and add them to the floor truss layout. This is to ensure that the trusses are correctly installed on site.

Note on stability: The connection details shown in this section should be verified by the project engineer to ensure lateral stability requirements of the building (and supporting beam) are met.

#### End Type 1

The most common end type is for bottom chord bearing on wall plate or steel section while also permitting upper wall frame to bear directly above. It may also be used for the connection to framing brackets.

Note: It is preferable to use 45mm end webs when fixing into framing brackets.

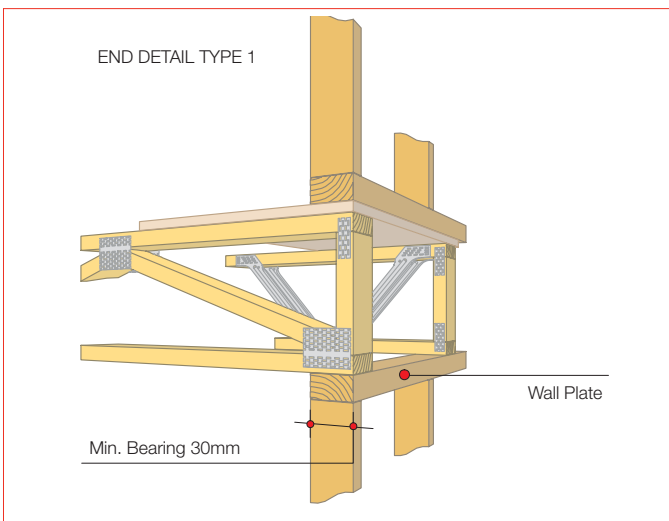

#### End Type 2

Similar purpose as End Type 1, however permits timber end bracing trimmers to provide lateral stability. It also accommodates minor site variations by allowing the setbacks to be curtailed if need be.

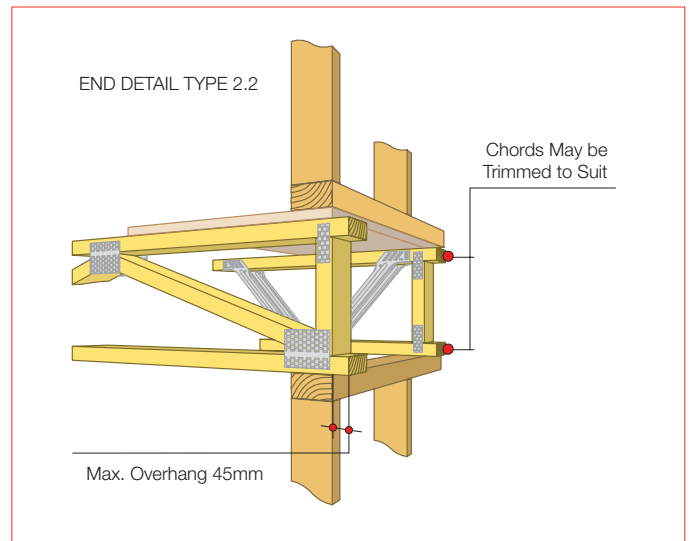
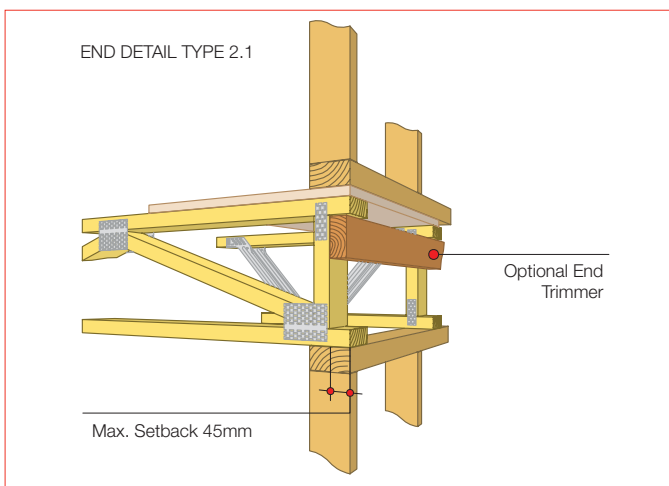

#### End Type 3

Accommodates ease of installation of timber end bracing trimmers while also supporting upper loadbearing wall frame. It acts as an additional bottom plate and supports the edge of the sheet flooring.

End type 3 is the preferred option out of all of the bottom chord bearing types, especially when supporting heavily loaded walls. Also refer End Type 6 (with double end-webs)

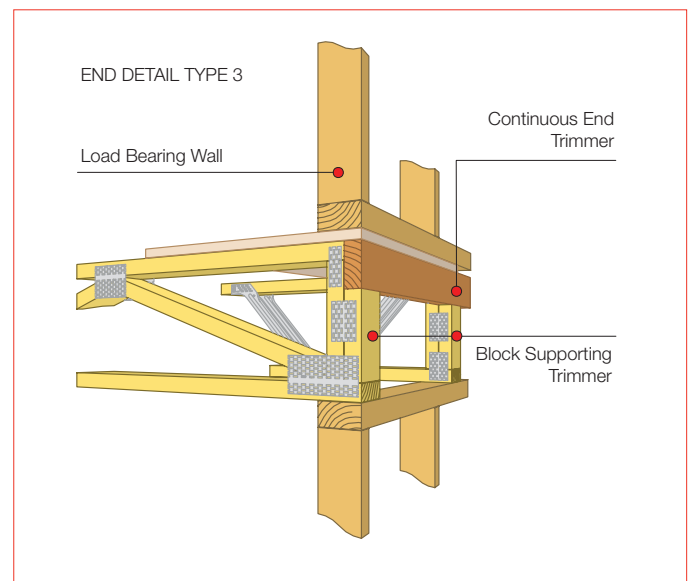

**End Type 4**

Suitable for bottom chord bearing on the bottom flange of a steel channel or universal beam while also maintaining continuation of the flooring over the top of the steel beam.

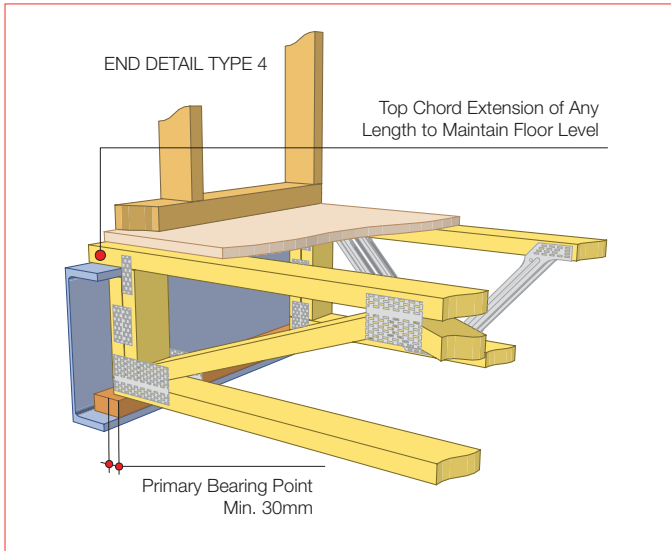

**End Type 5**

Flexible end type that comprises of a solid block incorporated within the truss, either nailed and glued or nailplated as shown. This block may be cutback at an angle either on site or in the factory to accommodate off-set walls from upper level or facilitate support into steel beams.

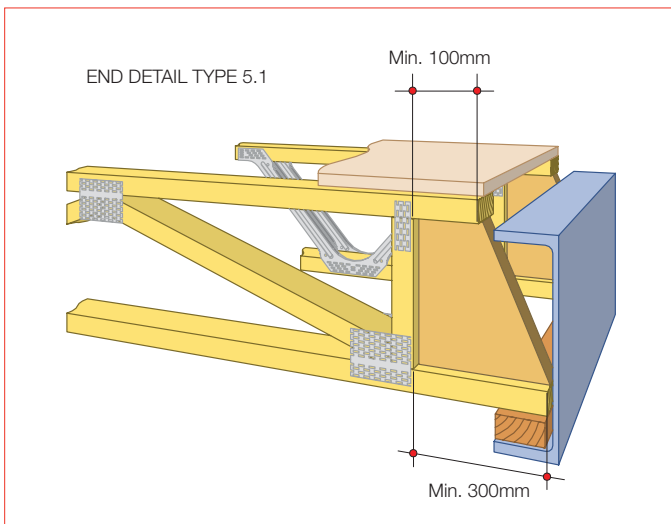

Trimable Ends: The nailed and glued solid block option may be adopted to achieve trimmable ends - especially useful when end supports are not parallel or when the true locations of the support are subject to minor variations. Contact a Pryda Design Office for further advice including information on timber/fixings and the limitations of these applications.

In some instances, an I-joist may be used in place of solid blocks. Contact a Pryda Design Office for further advice.

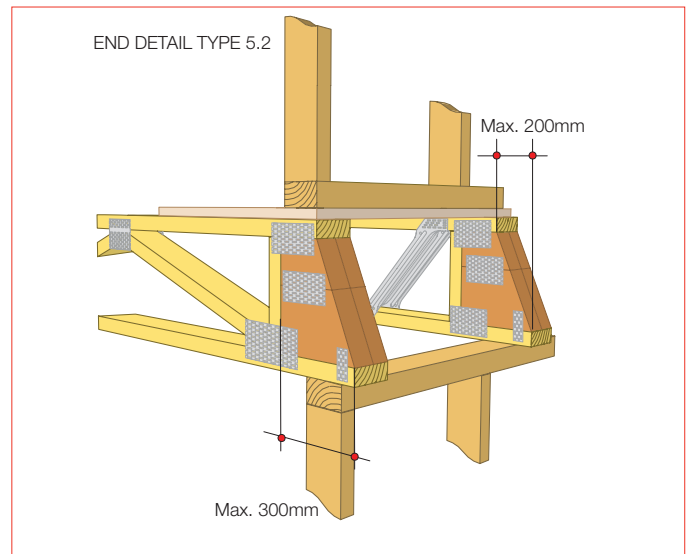

Alternatively, End Type 5 with a full width end block is suitable for cantilevering over lower storey walls and carrying upper storey load bearing walls.

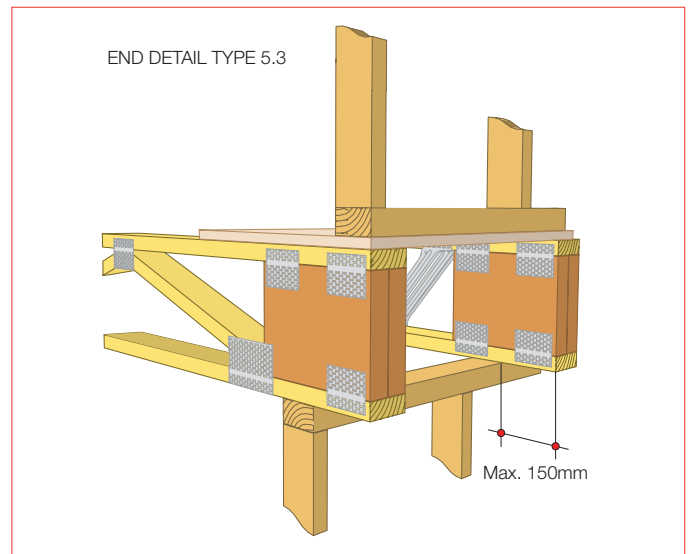

As an additional application, the blocking piece may be cut to suit to form pelmets (floor trusses as shown) or box gutters (rafter trusses)

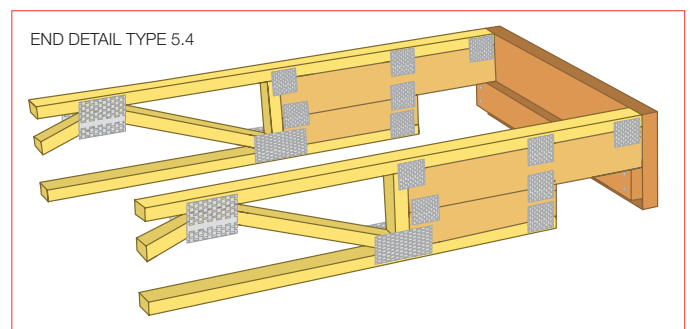



**End Type 6**

Standard bottom chord bearing with the capacity to transfer high loads from upper loadbearing walls.

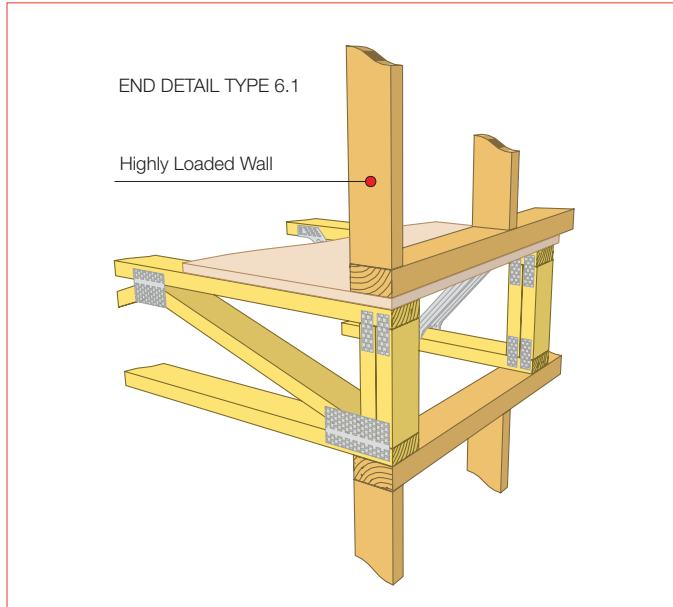

End Type 6 also provides extra timber nailing area when supporting trusses using Pryda Framing Brackets.

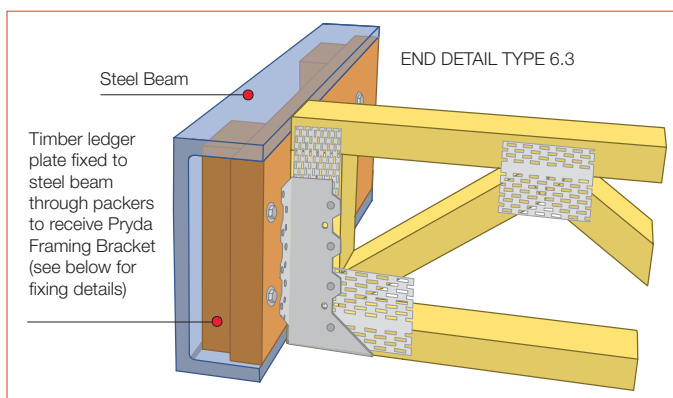
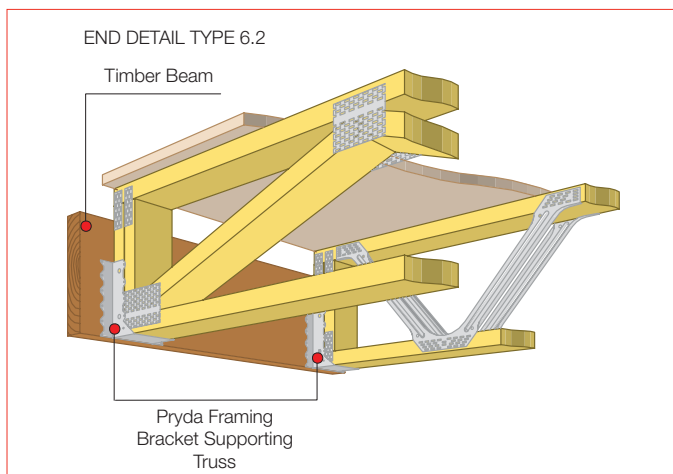

Note: Timber ledger plate (min. 190x35) should be fully bearing on bottom flange of steel beam, and usually fixed to web of beam through packers at 900mm c/c using 2/M10 bolts. Contact a Project Engineer for verification of fixing for commercial application.

**End Type 7**

Top chord support on timber floor beam, steel beam or waling plate. Promotes easy installation. It is advised that bottom chord should be restrained (skew nails minimum) to obtain best results.

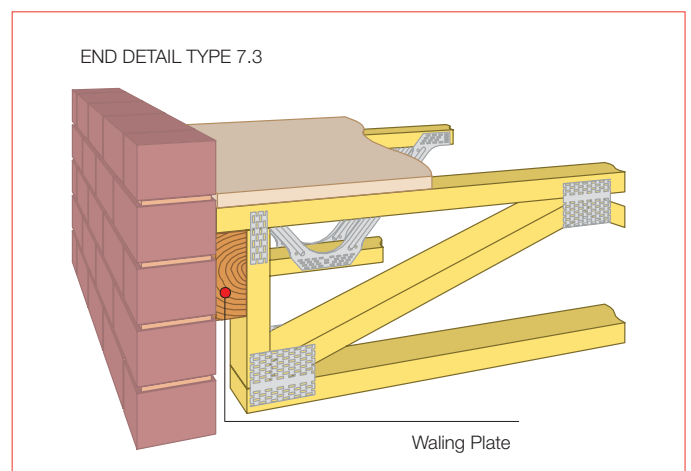
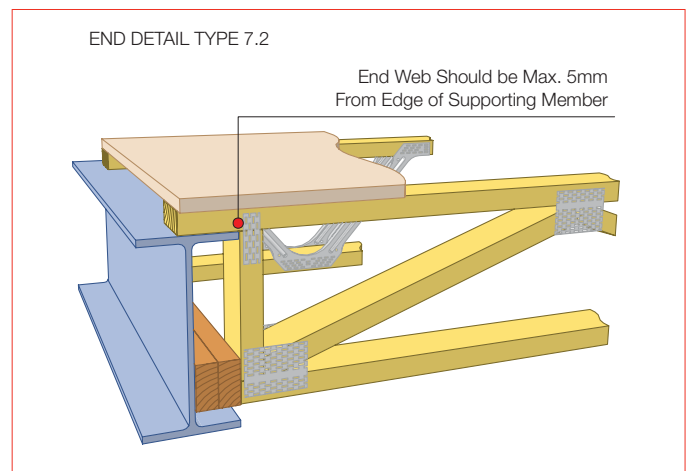
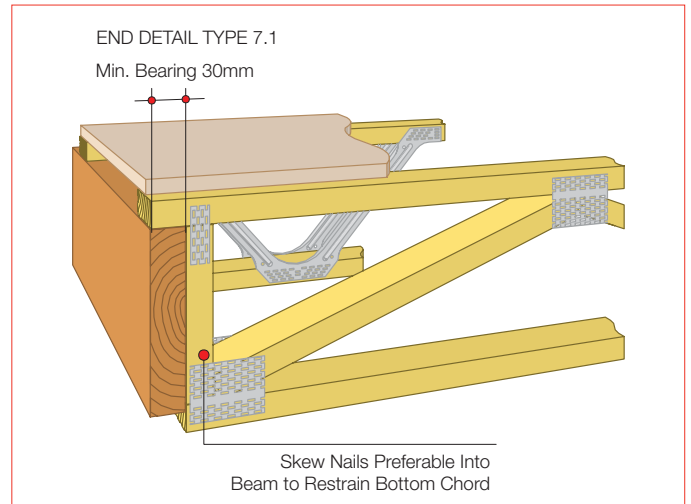

**End Type 8**

Similar purpose to End Type 7 but permits support member (waling plate) to be concealed at variable depths within the truss,

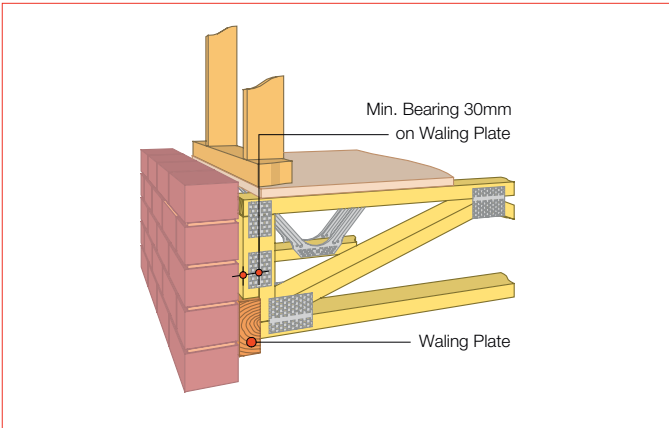

**End Type 9**

Permits floor trusses to be supported on the top chord while also housing the supporting beam within the depth of the truss. Encourages continuous ceiling lines under trusses.

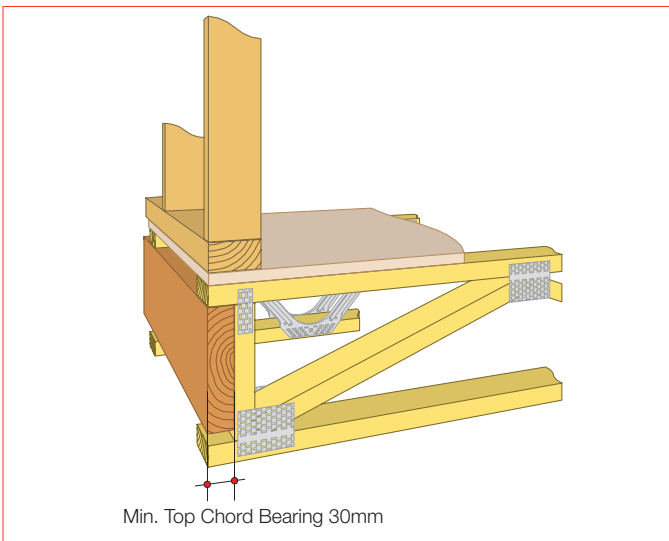

**End Type 10**

This end type is suitable for short internal cantilevers alongside stair openings.

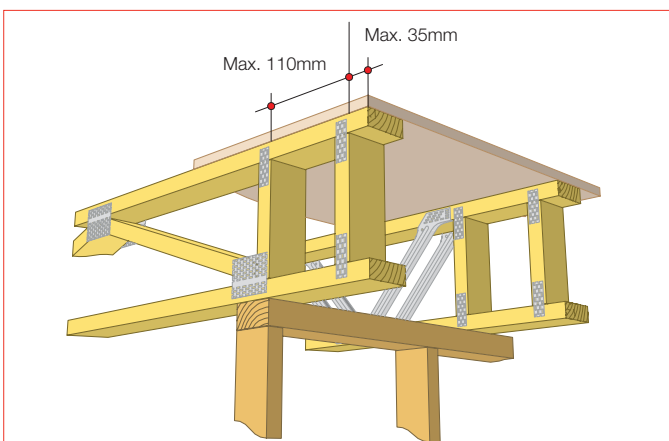

**End Type 11**

Permits support into steel channels and universal beams while maintaining a floor and ceiling level that finishes flush with the top and bottom flange.

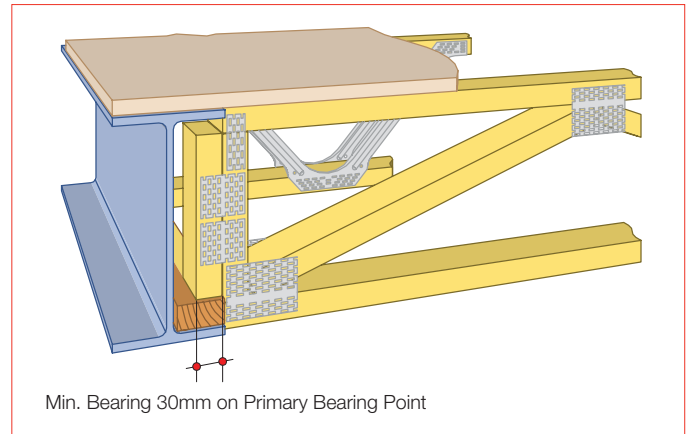

**End Type 12**

Permits bottom chord support into steel channels and universal beams with the bottom chord finishing flush with the bottom flange while also maintaining a floor level above the top flange.

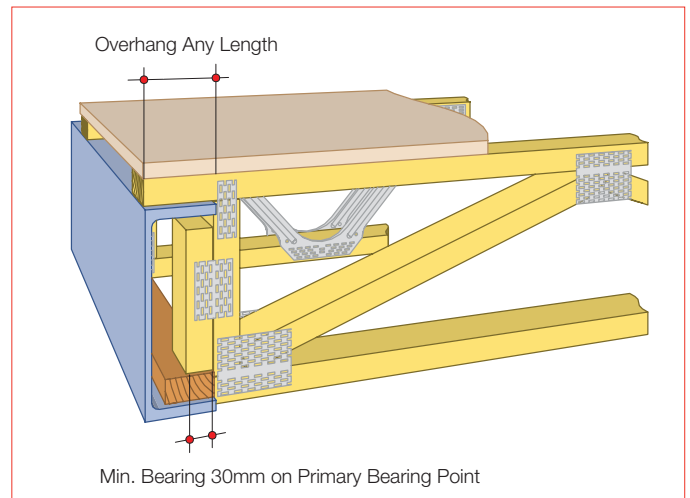

**Combination End Type**

A combination of end types may be used to suit site conditions, for internal beams supporting floor trusses from both faces. In the illustration below, floor trusses having End Types 6 and 8 are supported on a steel channel (PFC).

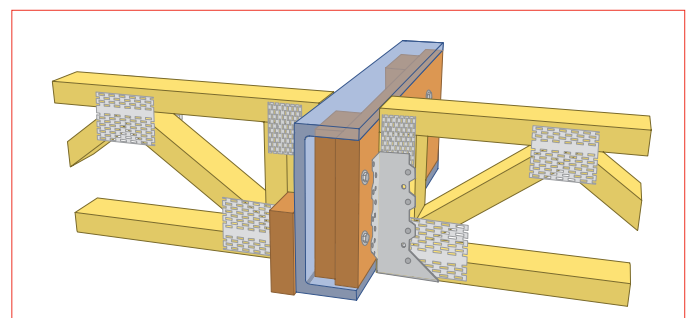

## Internal Walls

These details refer to all internal walls which are non load-bearing for gravity loads, but which may also be wind bracing walls. If the floor is to carry load-bearing internal walls, adopt guidelines given in page 12.

### Internal Non Load-Bearing Walls - Over Floor Truss

The floor truss system requires no additional stiffening when supporting non load-bearing walls; however special consideration is required for non load-bearing walls acting as wind bracing walls and those carrying wall tiles and other heavy cladding materials. Specifiers should notify the Pryda licensed fabricator of wall bracing positions and capacities.

### • Bracing Walls Parallel to the Floor Trusses

It is preferable to locate a floor truss directly under a non load-bearing bracing wall, and the supporting truss to be designed for reactions generated by these bracing walls. In order for this to happen, the truss designer requires sufficient information on wall bracing of the supporting upper level at the time of the design, in particular the exact locations of bracing walls and the resulting reactions at their anchor points.

However, if the floor trusses were designed without any consideration for bracing walls that are supported on the floor above, then the installer is required to take remedial measures on site. For bracing walls having capacities up to 3.0 kN/m, the trusses are required to be upgraded as illustrated below for a likely situation where the bracing wall is positioned between two floor trusses.

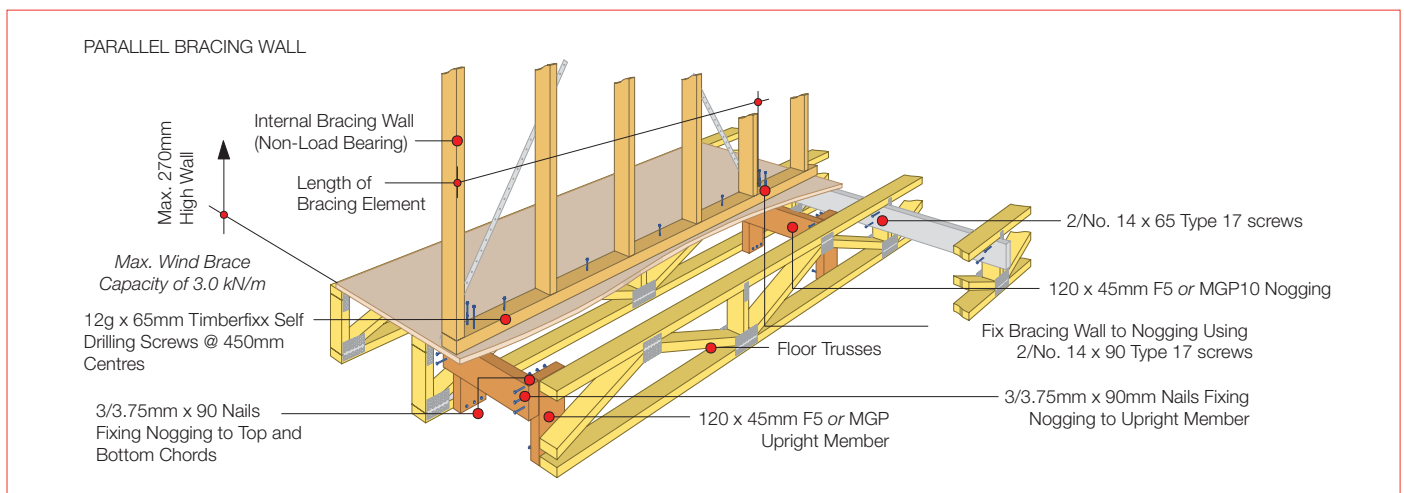

### • Bracing Walls Perpendicular to Floor Trusses

Again, it is preferable to incorporate the loading from bracing walls at the time of the floor design. Alternatively upgrade floor trusses as shown in the illustration below to resist bracing walls of capacities not greater than 3.0 kN/m.

*Note on floor trusses supporting bracing walls having capacities greater than 3.0 kN/m:*

It is prudent to consider these bracing walls at the time of the design as it becomes almost impractical to adequately upgrade truss to suit on site. Contact a Pryda Design Office for further advice.

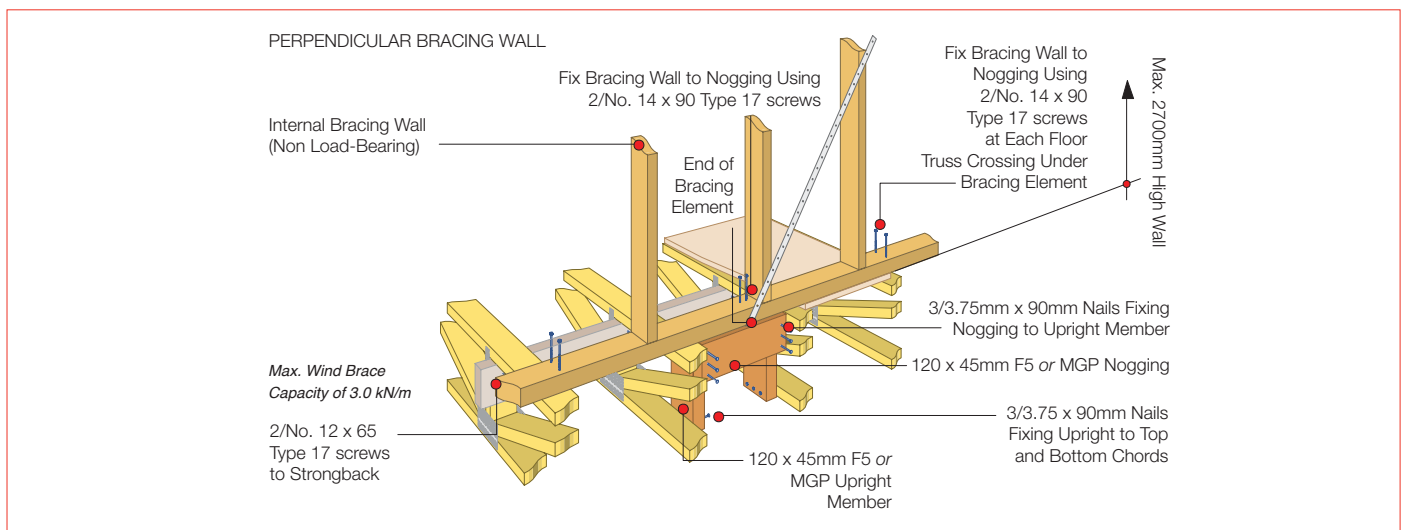

• Fitted Flooring

Where a fitted floor is being used, locate a double truss under each wall to provide support to both the wall and flooring. Alternatively, use supplementary ledger plates fixed to the side of the floor trusses.

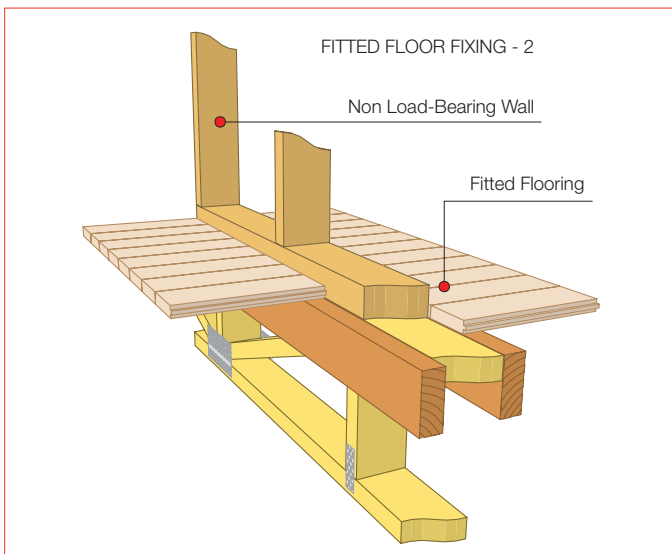
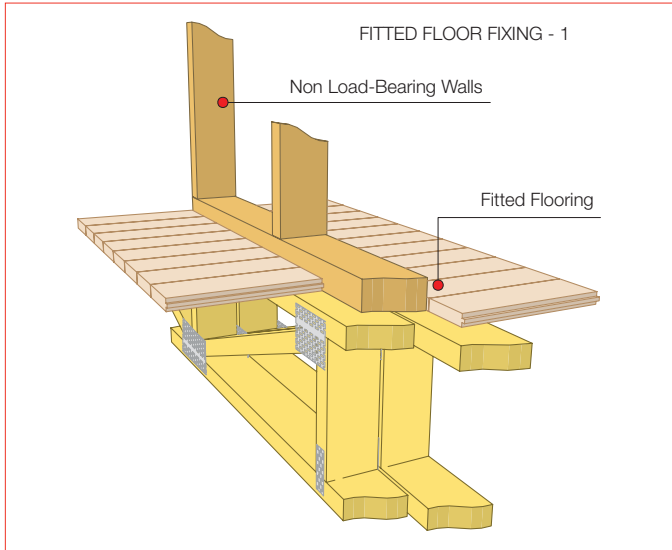

**Internal Non Load-Bearing Walls - Under Floor Truss**

Floor trusses must be adequately supported on the loadbearing supports nominated in the design. There may be a detrimental effect on the walls and the flooring system if the trusses bear on a non load-bearing wall. The tops of internal non load-bearing walls need lateral stabilizing by fixing to the truss bottom chords. The trusses must be allowed to deflect downwards, so Pryda Partition Hitches (product code: PHH) have been developed for this purpose, which should be nailed to the truss near the top of the slots.

**Internal Non Load-Bearing Bracing Walls – Under Floor Truss**

It is important that racking forces generated from stability and wind loads are transferred down through the structure to the foundations. The details below show how these forces can be transferred from the upper floor system, through truss bottom chords to lower storey non-load bearing bracing walls. Pryda Shear Connectors (Product Code: PSC) can be used for this purpose.

• Walls Parallel

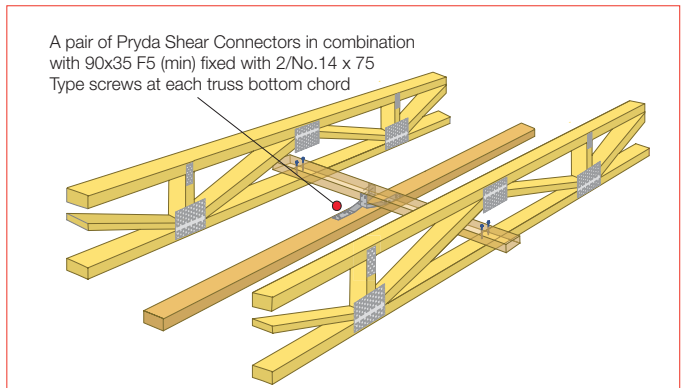

• Walls Perpendicular

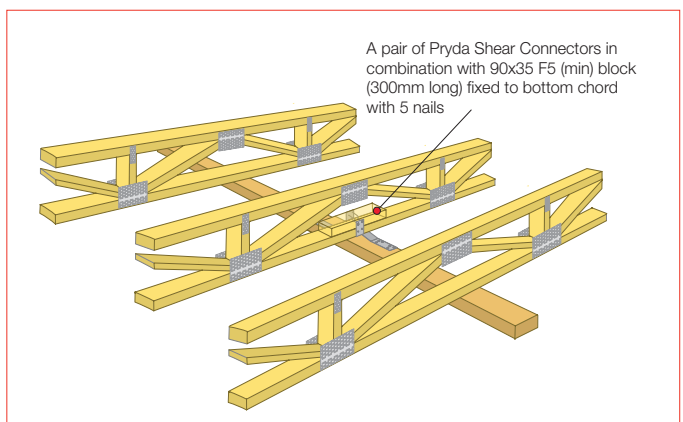

**Load-Bearing Walls - Under Floor Truss**

Important: Should an internal wall be required to support floor trusses, this intention should be made very clear on both the trusses and the truss layout. The supporting structure, footings, etc. should then be designed to cope with the high wall loads that can result.

Internal lower storey walls can be used for support to create single length trusses across the width of the building. Preferably, a double web with a gap will cater for small deviations in support positions, while a block insert of up to 600mm in length will accommodate larger deviations. Alternatively, if the exact location of the support is known, then a vertical web can be detailed at the support point.

• Internal Support Types

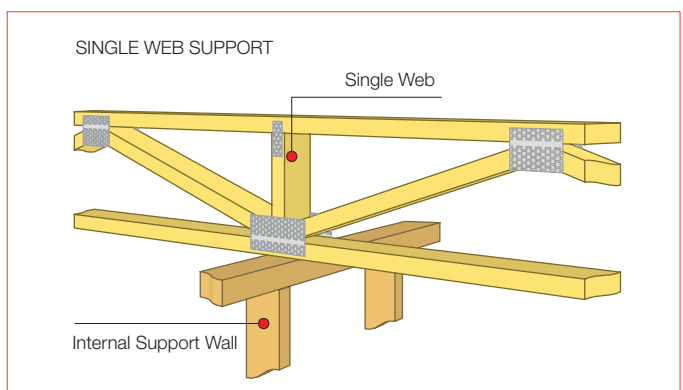

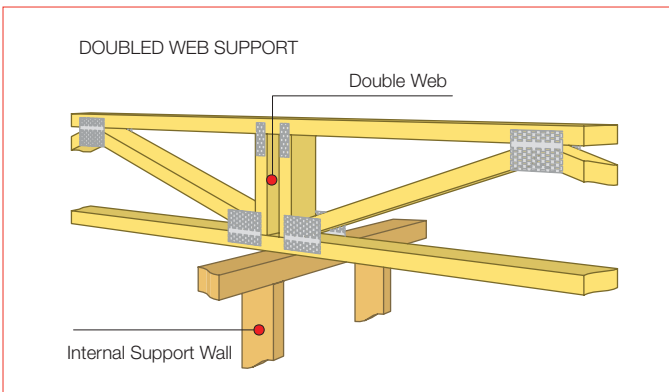

**End Truss Under Gable Roof**

Where the end floor truss is located under a gable end roof and is free spanning, it is appropriate to use a single floor truss as it is carrying a non load-bearing wall and floor only.

**End Truss Carrying Roof Loads Over**

Free spanning end floor trusses are required to be designed for both roof and wall loads.

Use guidelines given in page 12 (Loads from External Load-Bearing Walls) to compute loads that are required to be applied on the end-floor truss.

**Off-Set Load-Bearing Walls**

Use guidelines given in page 12 to compute loads from off-set load bearing walls.

**Support of Concentrated Loads**

Please refer to a Pryda licensed fabricator for an individual design if a floor is to carry a concentrated point load other than as specified below.

- For support of concentrated point loads refer above to the details for "Continuously supported end truss".
- As specified in detail below

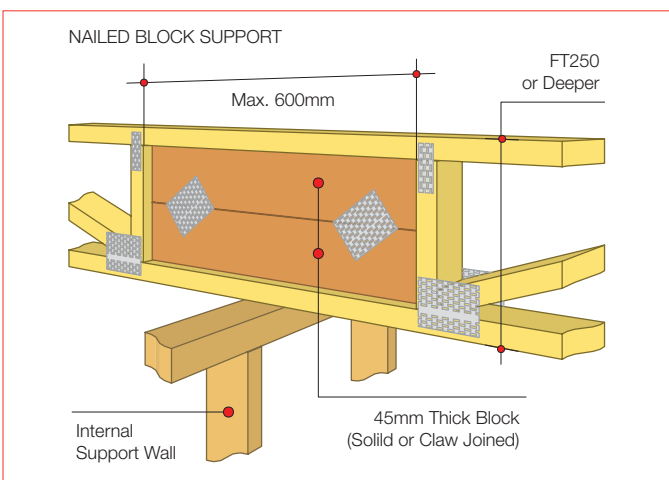

**External Walls**

These details are for floors that support external walls both load-bearing and non load-bearing.

**Fully Supported End Truss**

Where the end floor truss is supported along its full length by a lower storey wall or by continuous base brickwork or footing while carrying an upper storey wall above, a simplified floor truss, as shown, may be used.

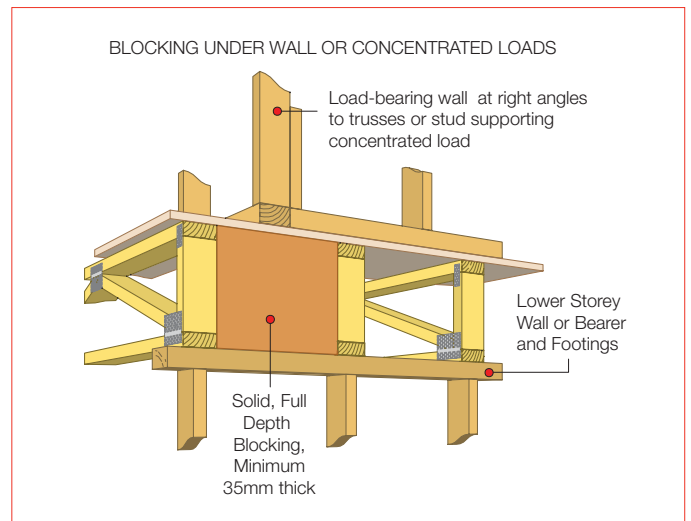
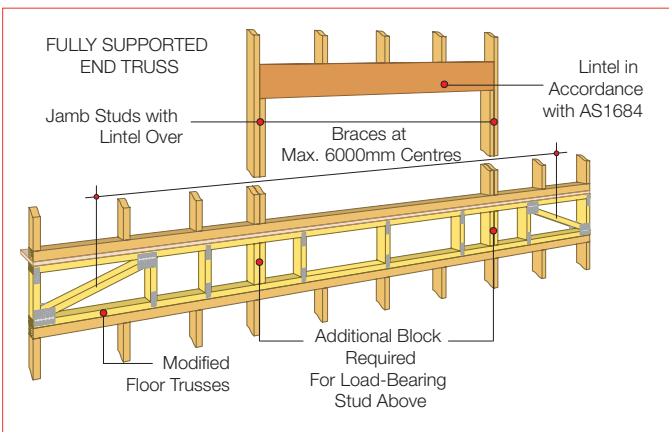

### Floor Openings

Pryda floor trusses can be detailed to suit an opening in a floor, e.g. as required to accommodate stairways. A header beam is normally required to support the incoming trusses while a double lamination standard truss is often suitable to carry each end of the header beam.

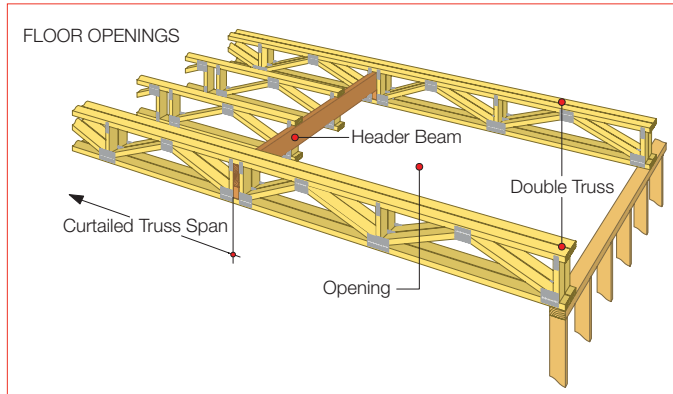

### Beam Pocket Detail

The trusses need to be detailed with a beam pocket wide enough to fit the header beam as shown. The header beam should be blocked hard up against the underside of the carrying floor trusses and nailed to each vertical web with 4/3.15 x 75mm nails.

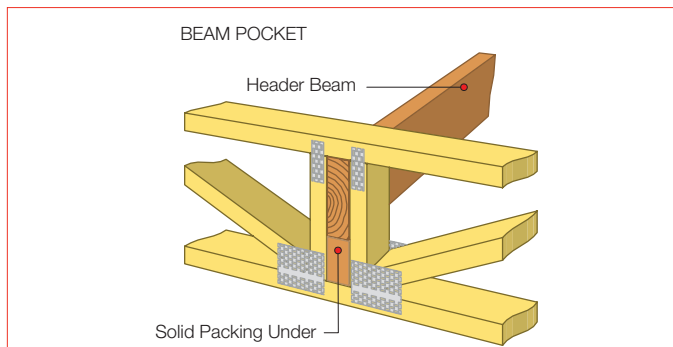

### Block Detail

Alternatively, a solid block (600mm long) fixed to the side of the trusses may support the header beam. The header beam may be notched into the solid block or fixed to the block using a Pryda Framing Bracket as shown.

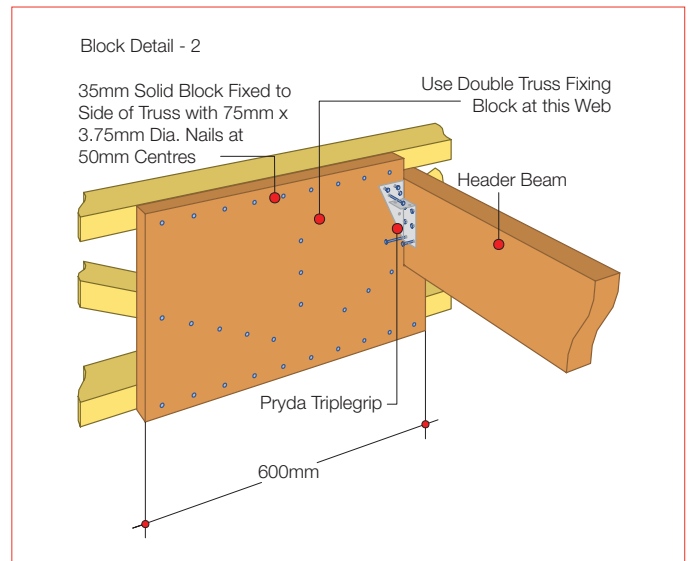
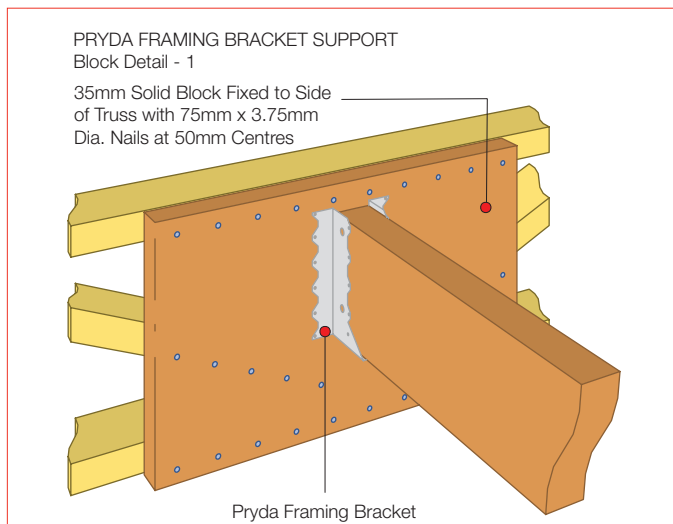

Alternatively, a solid block may be incorporated within the floor truss (as shown below) to receive supported beam.

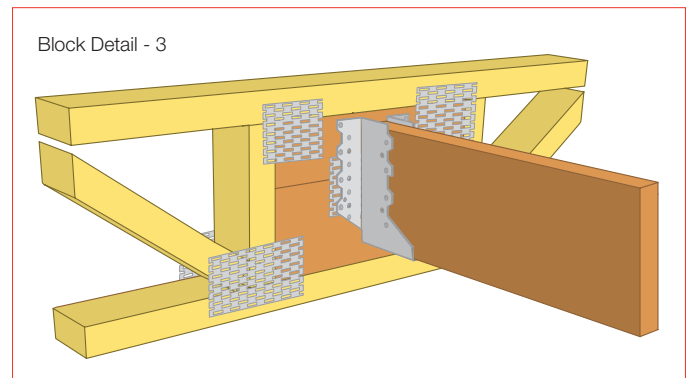

**Stairway Parallel to Trusses-Case 1**

Use Table 6 to determine header beam specifications for Case 1 only. The header beam (max. 2000mm span) supports the curtailed floor trusses and stair loadings from the upper flight of stairs.

**Table 6**

HEADER BEAM SELECTION TABLE	
Maximum Supported Floor Truss Span (mm)	Header beam (max. 2000mm span)
1500	190x45 LVL
2500	190x45 LVL
3500	190x45 LVL
4500	240x45 LVL

Note: the above header beam sizes are given as a guide only. These beams may be substituted by other sizes and grades, having similar stiffness.

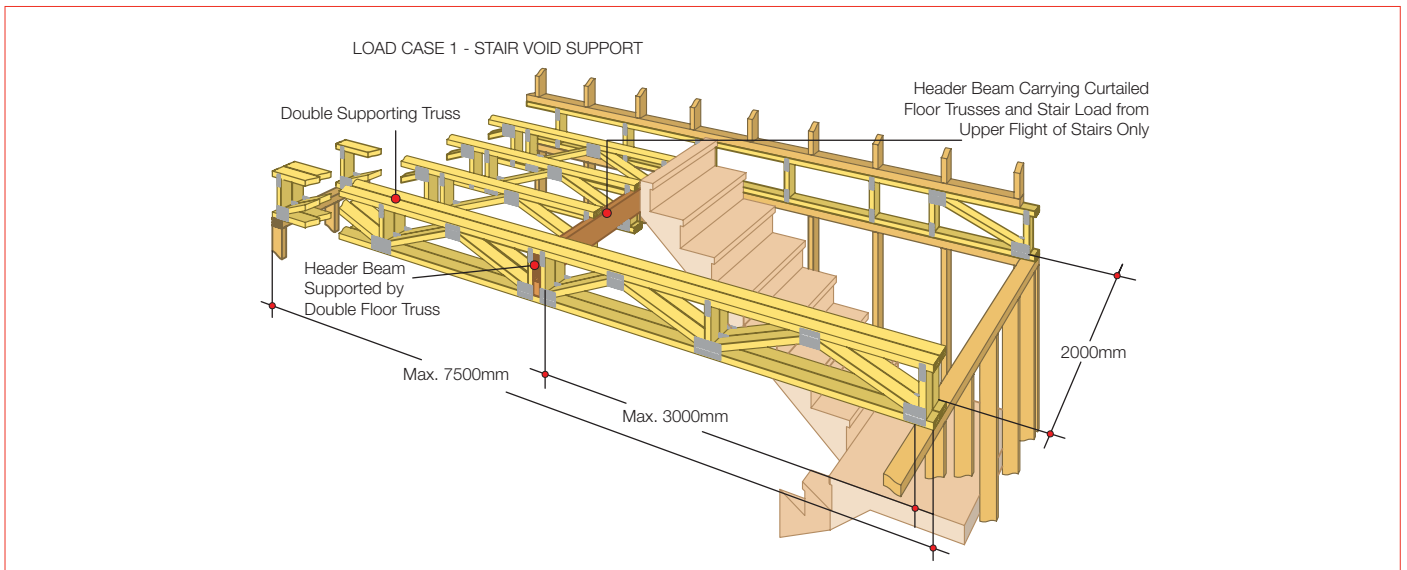

**Stairway Perpendicular to Trusses-Case 2**

Use Table 7 to determine header beam specifications for Case 2 only. The 900mm wide stairway runs perpendicular to the curtailed floor trusses and the header beam (max. 3500mm span) supports the trusses.

**Table 7**

HEADER BEAM SELECTION TABLE	
Maximum Supported Floor Truss Span (mm)	Header beam (max. 3500mm span)
1000	190x45 F17 or 200x45 LVL
2000	240x45 F17 or 240x45 LVL
3000	2/240x35 F17 or 200x63 LVL
4000	2/240x45 F17 or 2/240x45 LVL

Note: the above header beam sizes are given as a guide only. These beams may be substituted by other sizes and grades, having similar stiffness.

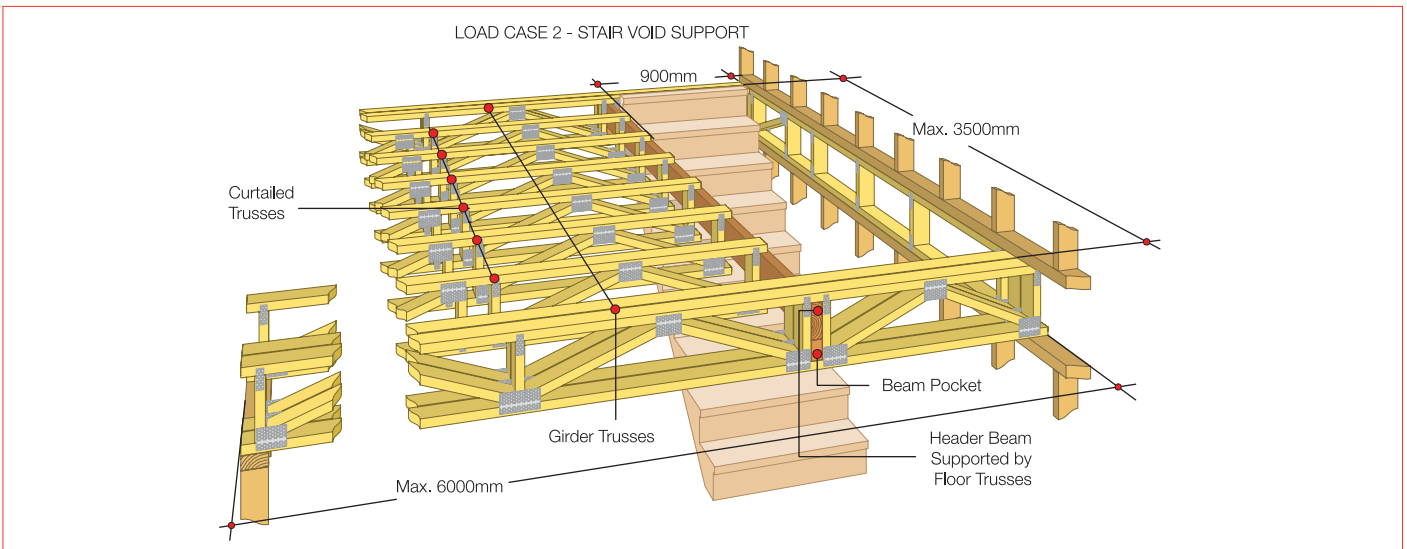

**Floor Set Down**

The ability to design and manufacture set down sections into the floor trusses provides significant labour savings in the following situations:

- In cantilever and balcony areas where the provision of adequate flashing and accommodation of different floor covering material thicknesses is critical.

Example of Set Down balcony

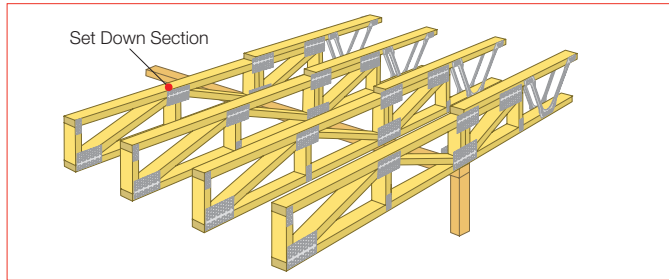

- Bathrooms, toilets and other wet areas may also require the floor surface to be set down. This will provide significant labour savings when other trades start installing bathroom fixtures, fittings and tiling.

Example of Internal Set Down area of floor

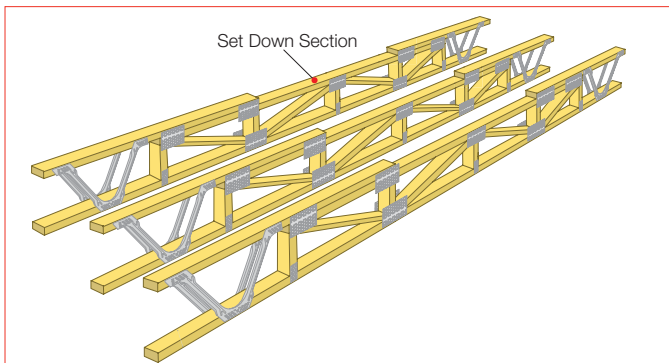

**Ducts for Mechanical Services**

The open web configuration of Pryda floor trusses permits ductwork and mechanical services to pass through the depth of the truss. Under domestic loads, Pryda Span and Longreach floor trusses may be detailed with voids up to 500mm long near the centre of the span. The span tables show depth clearances and the maximum pipe diameter that can be accommodated without special designs being required.

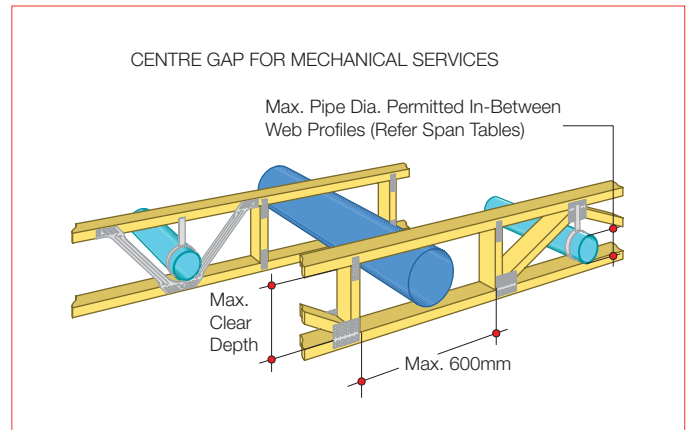

Pryda Floor software permits duct spaces to be detailed anywhere along the length of the truss, under specific design.

Table 8

Floor Truss Maximum Duct Space							
Truss Reference	Overall Depth with 2x45mm chords (mm)	Overall Depth with 2x35mm chords (mm)	Clear Depth with 2x35mm chords (mm)	Maximum found duct diameter (mm)	Maximum rectangular opening		
					Height (mm)	Width (mm)	
Longreach Floor Trusses	FT 250	260	240	170	130	170	500
	FT 300	310	290	220	180	220	500
	FT 350	360	340	270	230	270	500
	FT 400	410	390	320	280	320	500
Pryda Span Floor Trusses	PS 250	260	240	170	150	170	500
	PS 30	310	290	220	190	220	500
	PS 40	422	N/A	332	260	332	500



## Cantilevers

There are three common types of cantilevered balconies — internal, external, and those which support offset walls above.

### Internal Cantilevers

Found in two-storey construction where the first floor trusses are cantilevered only a small amount as an architectural feature. These cantilevers are built as a simple extension to the truss, with vertical webs introduced at the point of support.

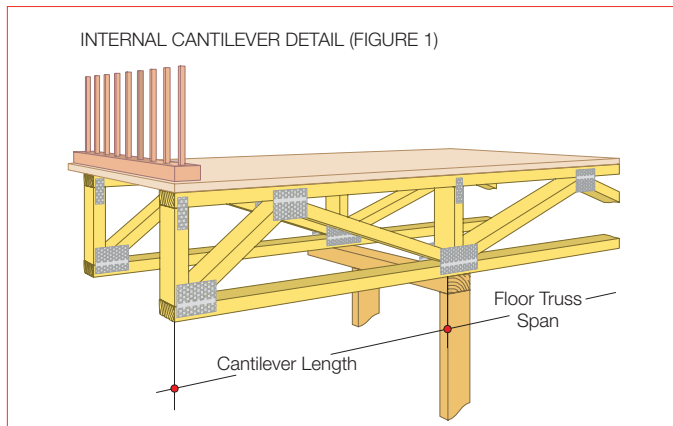

### External Cantilever (Balconies)

Floor trusses can be designed and manufactured to include a cantilever for support of fully sealed balconies, generally outside of the building, as shown in Figure 1. Alternatively, a cantilevered timber beam can be fixed on-site to one side of the truss as shown in Figure 3. The beam size and grade must be determined in accordance with appropriate span tables or software.

At every balustrade post, the truss cantilevers must include a timber block for fixing of the post. The block and fixing must be engineer designed. At the end trusses, 90x35mm minimum size stabilizers must be installed, extending across to the next truss and securely fixed to both trusses with a minimum of 2 x 5mmØ screws.

At the cantilever end, end trimmers must be fixed (as shown in Figure 2) to provide for truss stability and a cover lining to prevent moisture entry. The decking material must be screw fixed to the end truss at 150mm centres.

To ensure the trusses are correctly designed, it is essential that the truss fabricator be advised of the cantilever details, preferably on the building plans.

Imposed Actions (live loads) on balconies are higher than those on the general area of the floor. For example, a load of 2.0 kPa is applied on balconies of houses, whereas the general floor load is 1.5 kPa.

At the same time, a fully water proofed tiled balcony floor could have Permanent Actions (dead loads) almost 3 times the standard flooring loads.

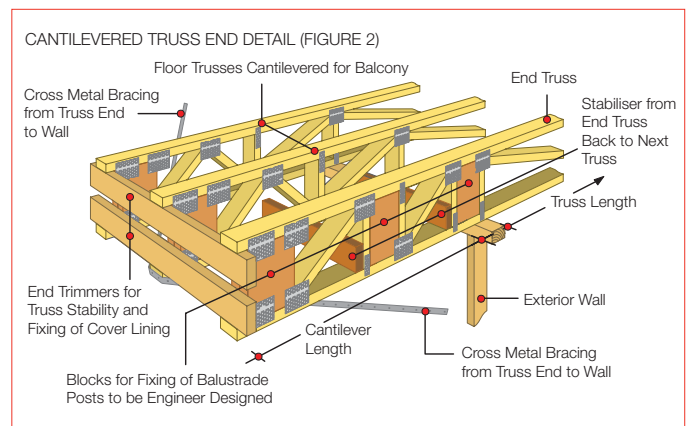

The cantilever balcony beam shall run a similar distance back into the floor truss and at least to the next vertical web past that distance. The cantilever joists are to be fixed to the truss bottom chord and vertical webs with 3.75mm diameter nails (75mm long into 35mm joists and 90mm long into 45mm joists) at maximum 200mm centres.

Note: These cantilever details are not intended for cantilevers carrying loadbearing walls over. In this instance, refer to a Pryda design office for a special design.

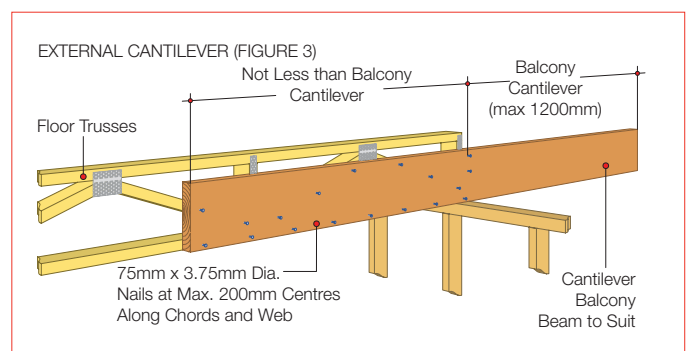

Note: If cantilever beams are used in an exposed environment, ensure a suitable damp proof course (or material) is provided between the joist and the floor truss.

### Cantilevered Support of Off-Set Walls

A common cantilever issue encountered is one in which the timber clad second storey frame is offset 150mm outside the lower storey frame. This permits the upper storey external wall cladding to finish flush with the lower storey brickwork. As a result, the floor trusses are cantilevered to support the upper storey roof loads and transfer these down to the foundations via the lower storey walls. Often this issue occurs parallel and perpendicular to the span of the floor trusses.

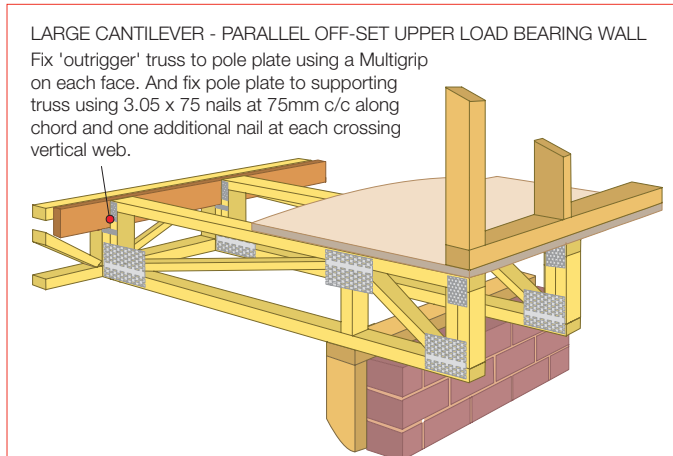
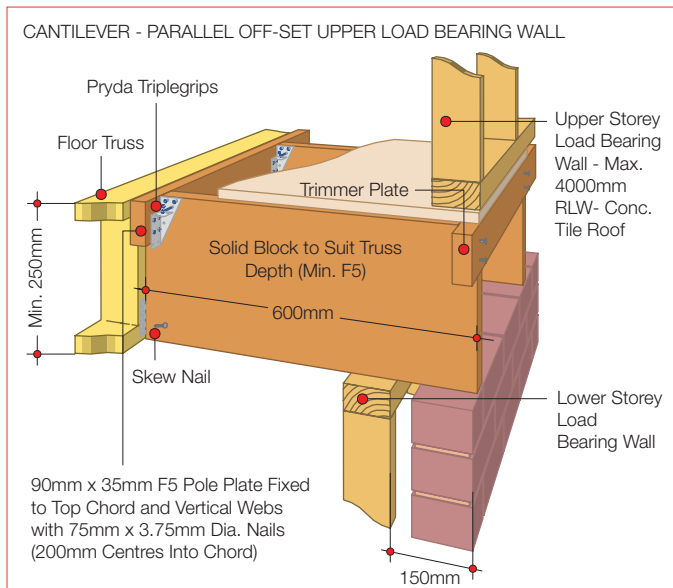
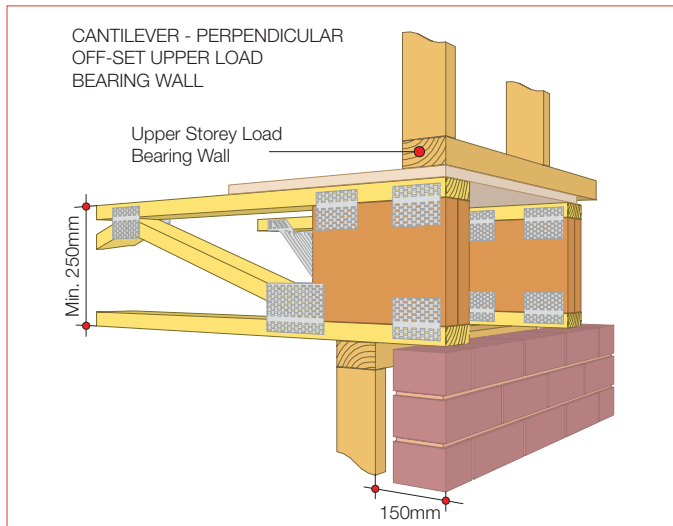

### Outrigger Support of Off-Set Walls

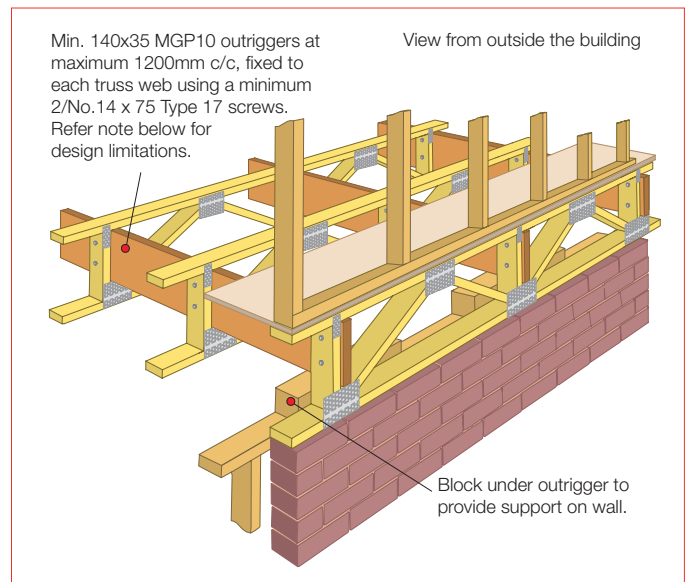
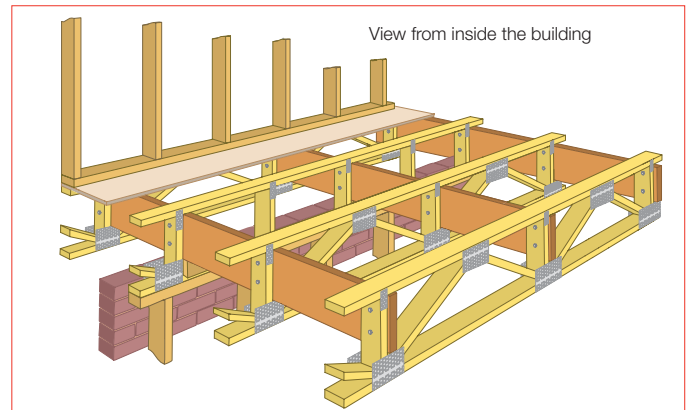

**Strong-Backs**

Strong-Back beams run perpendicular to the trusses and are used to spread footfall impact loads to adjacent trusses. They are required for all residential floors and some of the lighter commercial floors.

Strong-Backs are not required for trusses up to 3.5m in span. For trusses 3.5m to 6m span, use one row of Strong-Backs located close to midspan. For trusses above 6m span use 3 rows of Strong-Backs located one row at midspan, and two further rows located at each of the quarter points.

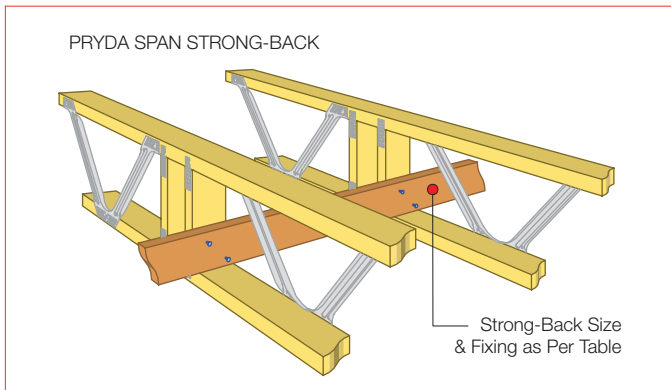
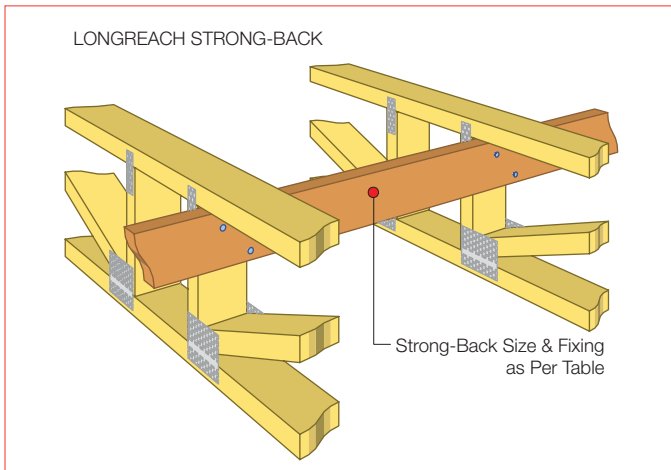

Strong-Backs should be fixed hard up against the vertical web, but may be fixed up against the top chord or the bottom chord to suit. Fixings may be hand hammered 75 x 3.75 nails, or power driven 75 x 2.9 nails, or No.14 x 75 Type 17 screws. Screws provide the best performance as they are more rigid, they clamp the timber components together, and they prevent squeaks due to various floor components loosening over time.

Where Pryda Span trusses have been used, and there is no vertical web close to the desired location of the Strong-Back, a supplementary vertical web may be nailed to the side of the truss instead with 2 nails to the top chord and to the bottom chord, to provide a fixing for the Strong-Back.

**Table 9 – Strong-Back Size and Beam Selection**

Nominal truss depth (mm)	Strong-Back depth and grade (all 35mm thick)	No. of fixings per connection
200	90 F5/P10 or 70 F17	2/nails or 1/screw
250	120 F5/P10 or 90 F17	3/nails or 2/screws
300	140 F5/P10 or 120 F17	3/nails or 2/screws
350	140 F5/P10 or 120 F17	3/nails or 2/screws
400	140 F5/P10 or 120 F17	3/nails or 2/screws

Note: these are minimum recommended sizes only. Larger Strong-Backs may be used in some instances to achieve better floor performances.

**Splice Detail**

In locations where the Strong-Back needs to be joined, either of the following methods may be used:

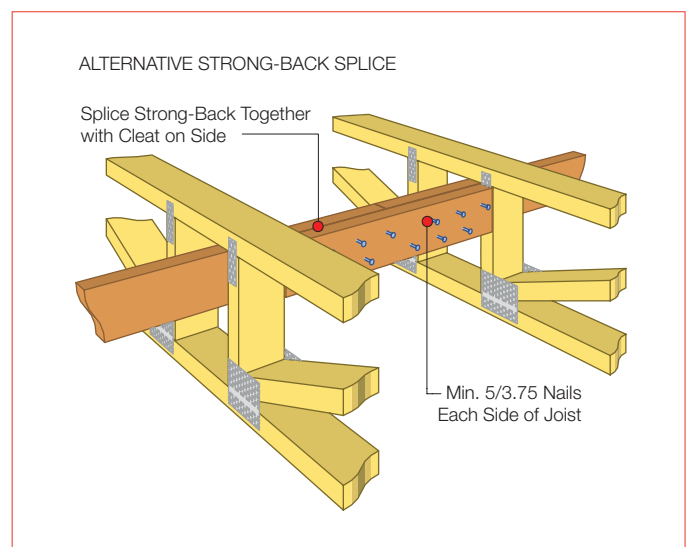
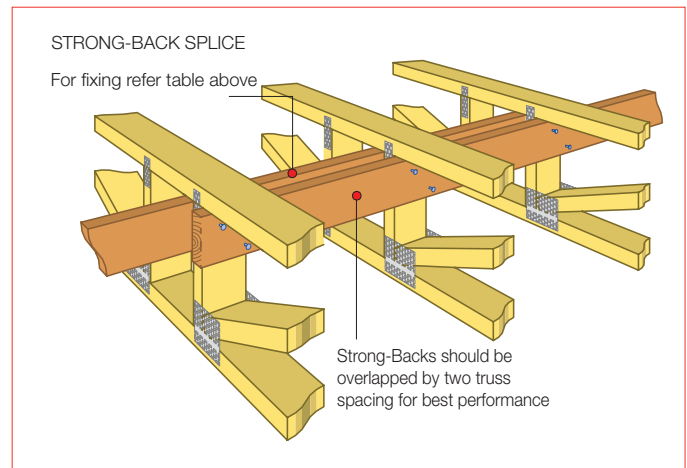

### Non-Aligned Strong-Backs

In cases where different adjacent spans cause the Strong-Backs to be out of alignment, the following detail may be adopted. Vertical blocks of 90 x 35mm are fixed with 2/3.75 diameter x 75mm nails to both top and bottom chords. Strong-Backs are then fixed into the side of the block and the preceding vertical web with the number of nails specified in the table.

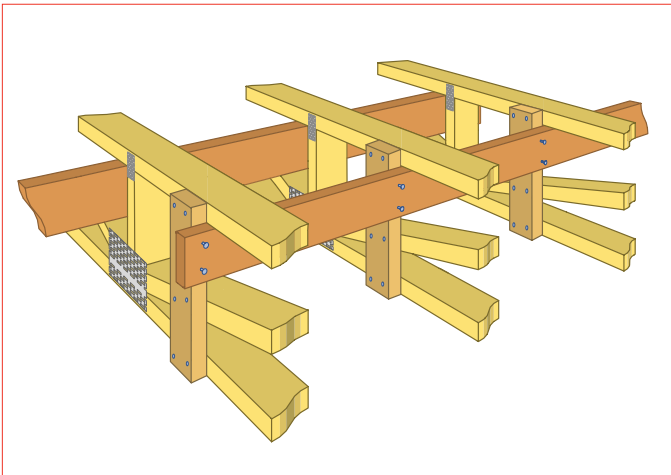

### Strong-Backs Not Required

Strong-Backs may be omitted from floors when:

- The floor has been designed for live load of 3000 Pa or greater.
- Either 25mm F11 plywood, or 2 layers of 19mm plywood (or better) has been used

In these situations, either the truss will be very stiff due to the high design load, or the flooring itself is capable of dissipating human footfall impacts.

Instead, use 90 x 35 F5 (on flat) lateral ties fixed to the bottom chord, located 3000mm apart (max.).

## STABILITY

### General

Pryda floor trusses must be braced back to their supporting structure for stability in a similar manner to the bracing stipulated by AS1684-2010 for solid deep joists. Use diagonally placed Pryda Strapbrace at 2700mm centres maximum at the ends of trusses and at any internal wall supports. Alternatively, a continuous trimming beam may be used at the end of each truss — see End Type 3 - with diagonal bracing at the end bays only. This bracing may be used as part of a wind bracing system.

### Wind Bracing

The wind force on a building must be transmitted through the roof, walls and floors to the footings and ultimately to the foundation.

Considering a timber joist or trussed floor, the floor stability bracing or blocking of walls or bearers will help to transmit these forces and may be sufficient to resist the entire wind load.

In some instances the floor stability bracing or blocking may not be sufficient and more bracing is required. It is essential therefore that the building designer, design the additional floor bracing required and that the builder correctly installs this bracing.

Consideration should be given to AS1684-2010 Section 8 for more thorough analysis of the interaction between the roof, walls and floors in forming a complete and adequate bracing system. Also considered is the effect of voids on the performance of bracing diaphragms. If in doubt consult your local Pryda design office.

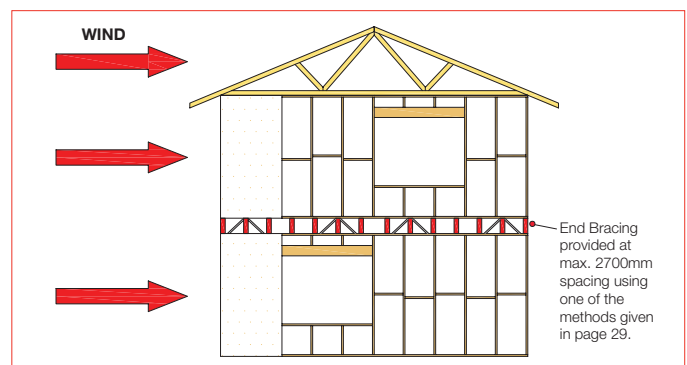
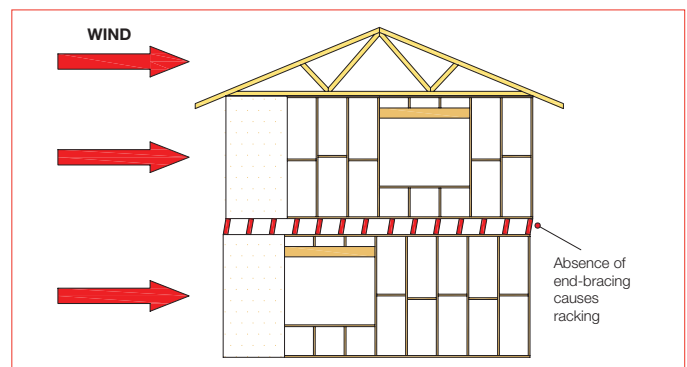

### Lateral Bracing of Floor Trusses Chords

Pryda floor trusses are braced laterally at the top chord level by the flooring material and at the bottom chord level by the ceiling lining. If there is no ceiling fixed directly (or by battens) then 90 x 35 binders must be provided on the bottom chord at 3000mm centres maximum.

**End Bracing**

- Method 1: Strap brace wrapped round wall plate (preferred method)

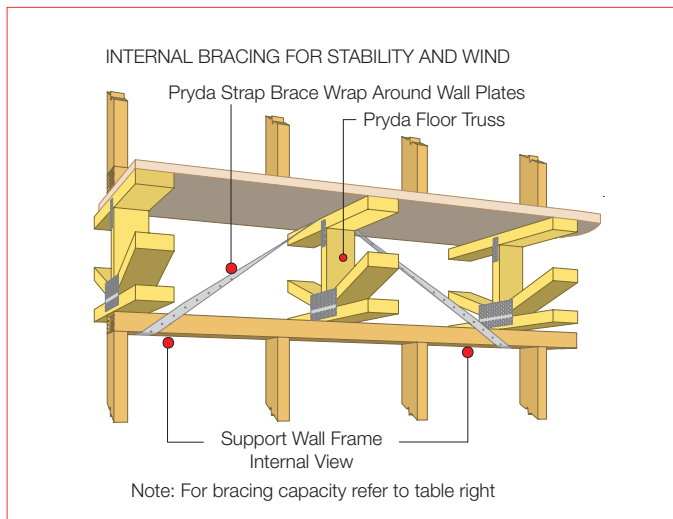
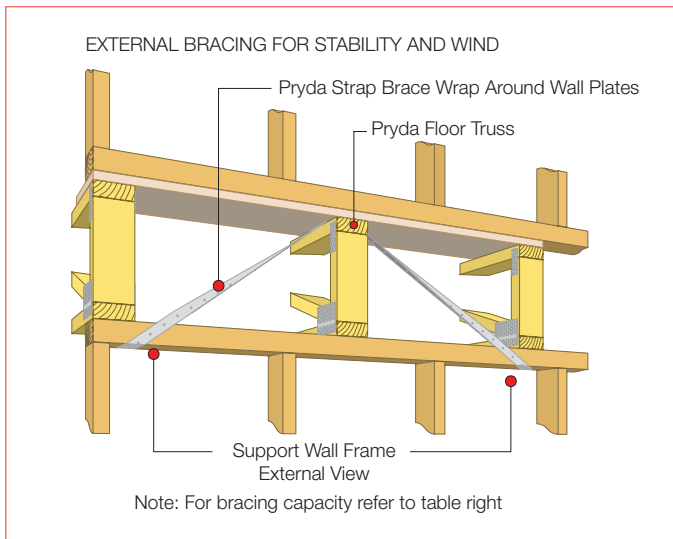

- Method 2: Strap brace nailed to side of wall plate

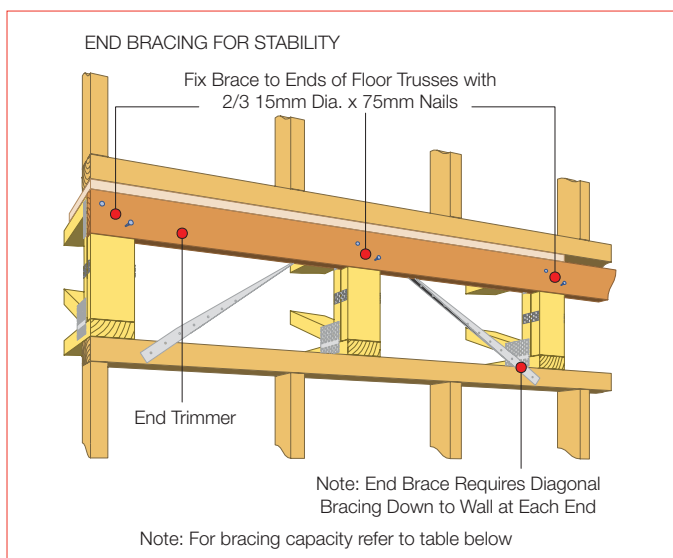

**Table 10 – Bracing Unit Capacity**

Pryda Strap Brace Code	Size	Method 1	Method 2
		Fixed to face and wrapped under the plate	Fixed only to face of plate
SB103	30 x 1.0 mm	4.8 kN	1.3 kN
SB123	32 x 1.2 mm	6.6 kN	1.3 kN

**Notes:**

- (i) Maximum angle of brace to top plate = 45°
- (ii) Method 1 fixing: 2/3.15 x 35 mm Pryda Timber Connector nails on face of plate and underside of plate
- (iii) Method 2 fixing: 2/3.15 x 35 mm Pryda Timber Connector nails on face of plate only
- (iv) 3/2.3 x 32 mm SHEG Duo-Fast machine driven nails (or equivalent) may be used in place of 2/3.15 x 35 mm Pryda Timber Connector nails

**Product Codes**

- OSNGB = 3.15 x 35 mm Pryda Timber Connector nails
- D40810 = 2.3 x 32 mm SHEG Duo-Fast machine driven nail

**Bracing Walls Supported by Cantilever**

The ends of cantilevered trusses or beams supporting (over lying) bracing walls require bracing with diagonal metal bracing back to the (under lying) supporting wall frame refer to detail below. Bracing to be fixed in accordance with recommendations of AS 4440-2004. Include detail/table of how much bracing is required given different bracing capacities of "bracing" wall over.

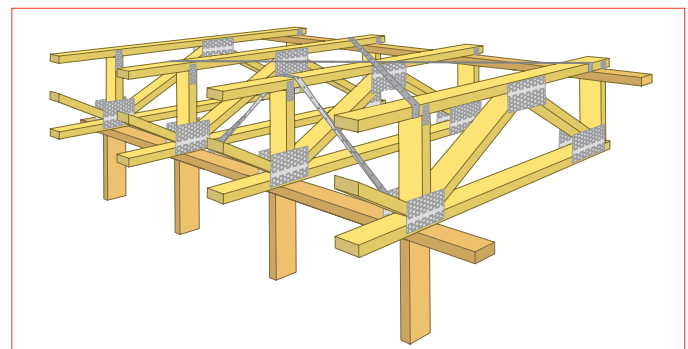

**Fixings at Supports**

Each truss shall be held onto its supporting plate/bearer by a minimum of 2/75 x 3.15mm diameter nails if preferred a better fixing may be achieved by using one Pryda Minigrip (Product Code: MG5) with 3/35 x 3.15mm diameter Pryda Timber Connector Nails per tab.

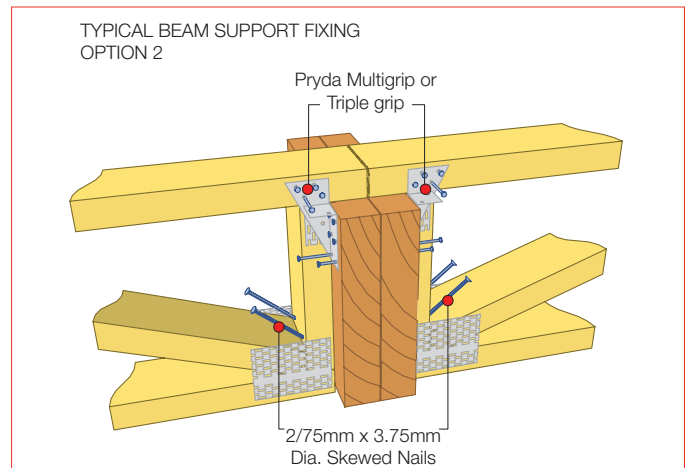
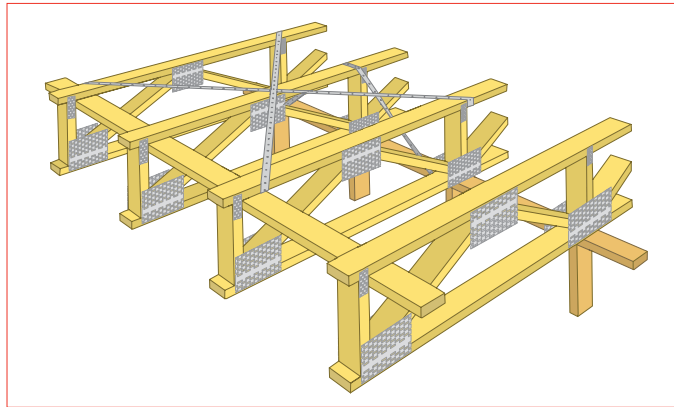

**Face Fixing of Floor Trusses**

**Domestic Floors**

Trusses can be supported on loadbearing walls or from the face of beams or bearers using Pryda FB94152 Framing Brackets (for 90mm trusses) or Pryda FB72163 Framing Brackets (for 70mm trusses), fixed to the supporting member with 35x3.15 dia Pryda Timber Connector Nails or No.12 x 35 Type 17 screws.

These brackets are capable of carrying support reactions (dead+floor live) in excess of 9.0 kN, using a total of 18 nails or 6 screws in JD4 timber.

The following tables provide maximum spans that Pryda Framing Brackets are capable of supporting:

Note: Joints are assumed to be Category 1 (AS1720.1:2010) and the supporting timber beam has a joint group of JD4 or better.

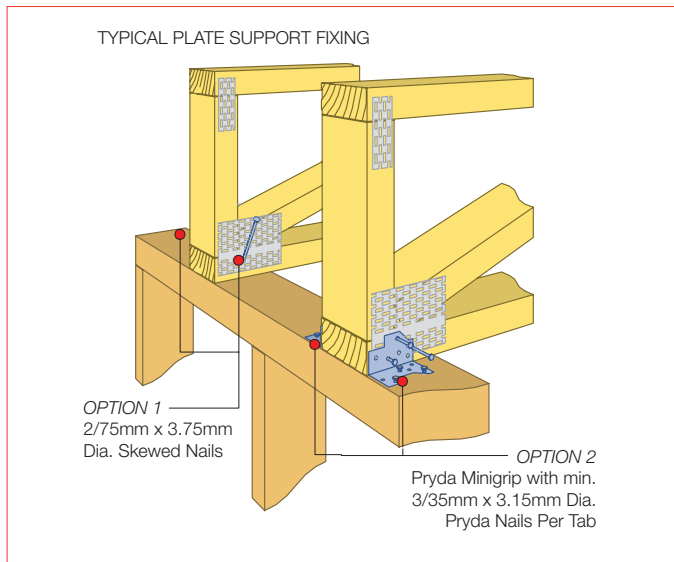

When supporting trusses on steel or timber beams via top chords it is preferable to restrain the bottom chord using skew nails while the top chord should be fixed to the supporting beam using screws or Pryda Triplegrips. This practice improves the stiffness of the floor by minimizing movement and vibration at the supports.

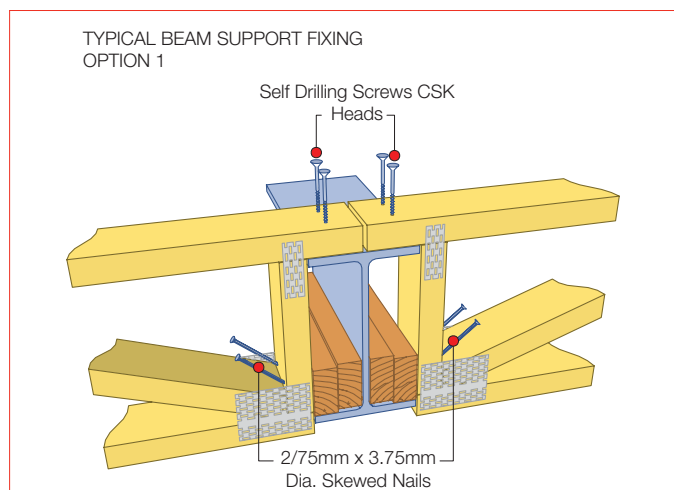
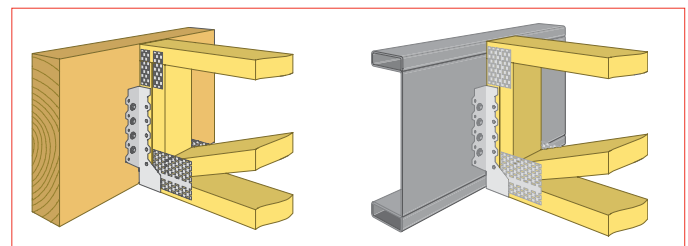

**Framing Brackets and Fixings**

**Table 11a – Domestic Loads**

Total Fixing into JD4 supporting beam	Maximum Spans (mm) for Domestic Loads - 1.5 kPa/1.8 kN (450mm/600mm truss spacing)	
	450 c/c	600 c/c
8 nails or 4 screws	6400	4800
12 nails or 5 screws	8900	6700

**Table 11b – Commercial Loads**

Total Fixing into JD4 supporting beam	Maximum Spans (mm) for Commercial Loads (450mm truss spacing)	
	3.0 kPa/2.7 kN	5.0 kPa/4.5 kN
12 nails or 5 screws	5200	Not Suitable
18 nails or 6 screws	7600	4900

Note: A permanent load of 0.80 kPa is assumed in the computation of maximum spans. The floor truss is assumed simply supported.

**Table 12 – Design Capacities per Framing Bracket**

Framing Bracket Code	Fixing to Supporting Beam (Beam A)	1.2G+1.5Qf (Dead +Floor Live Load)			Fixing to Supported Beam (Beam B) mm
		Design Capacity $\Phi N_j$ (kN) for Joint Group:			
		JD5	JD4	JD3	
FB70200	24 Nails	10.0	11.9	15.0*	3 nails
	10 Screws	10.1	14.2	15.0*	13 nails
					7 screws
FB72163	18 Nails	7.8	9.4	13.0	3 nails
	6 screws	6.4	9.1	12.8	10 nails
					6 screws
FB90200	26 Nails	10.8	12.9	15.0*	3 nails
	10 Screws	10.1	14.2	15.0*	13 nails
					8 screws
FB94152	18 Nails	7.8	9.3	13.1	3 nails
	6 screws	6.4	9.1	12.8	10 nails
					6 screws

Note: For more detail refer Product Guide [www.pryda.com.au](http://www.pryda.com.au)

**INSTALLATION**

For more specific information relation to good site practice and workmanship refer to AS 4440-2004 and the Pryda Floor Truss Installation Guide however consideration should be given to the following:

- Documentation for site
- Transportation to site
- Lifting
  - Delivery to site
  - Installation
- Temporary storage
- Protection from the weather
- Modification of trusses and manufactured components
- Connection and fixing details
- Clearances

Particular attention is to be given to the proper stacking of material during the construction stage. It is best to be avoided if possible however if in doubt contact Pryda for advice.

**Construction Loads**

Particular attention is to be given when temporarily stacking materials on floor trusses during construction. Important points to consider:

- Ensure trusses and their supports are braced prior to stacking materials.
- Materials should be stacked in such a way that the loading is distributed over as many trusses as possible. It is preferable to position sheets with the long edge perpendicular to the trusses (see figure below). The maximum depth of pack (particleboard, plasterboard etc) should be maintained at 400mm (or not more than 300 kg/sqm)
- Try to stack materials close to a support, if not at least away from mid-span of trusses.
- If materials are stacked parallel to trusses (not the preference), ensure five sets of bearers are used to distribute loads. Also, the stack depth should be maintained at a maximum 300mm.
- Safeguard trusses from impact loads – trusses can get damaged when loads are dropped on them, even if the load is small.

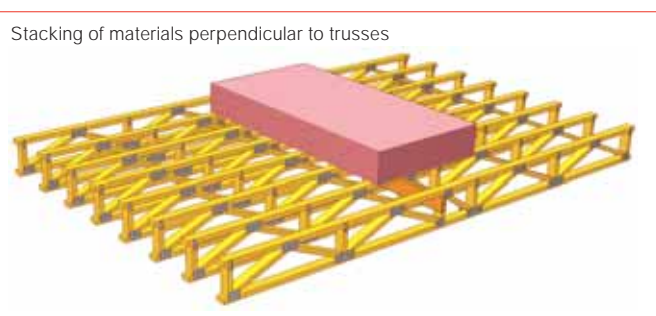
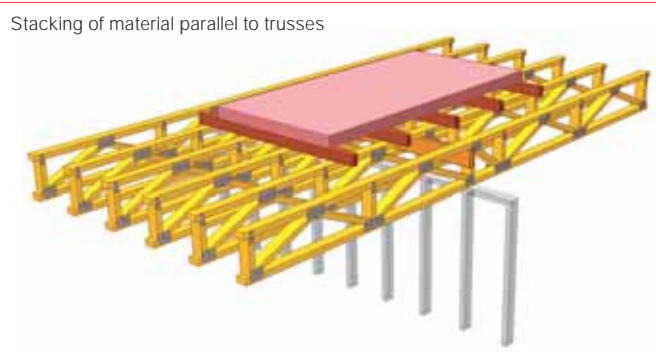

## PRYDA RAFTER TRUSS SYSTEM

### INTRODUCTION

Pryda Longreach and Pryda Span trusses are also available for use as part of the Pryda Roof Truss System. The design and manufacturing principles use similar standards to the floor trusses and therefore the benefits associated with Longreach and Pryda Span can be also be attained in roof construction.

Longreach and Pryda Span trusses are suitable as roof purlins or rafters for all roof materials. Pryda roof trusses are generally made to order with special fixing requirements for stability and tie-down against wind uplift.

There are two types of roof truss designs covered in this guide – Purlin trusses and Rafter trusses. The criteria for overall height, clear height and construction are the same as for floor trusses. For detailed information refer to Appendix F.

#### Purlin Trusses

Purlin trusses run parallel to the ridge and are perpendicular to the plane of the roof. The steel sheeting is fixed directly to the top of the chord, and a ceiling is assumed to be attached directly (or with battens) to the bottom chord.

#### Rafter Trusses

Rafter trusses are often laid horizontally (like floor trusses), and are overlaid with graded purlins which provide a fall to the roofing material. However, a small pitch may also be given to the rafter trusses with battens overlaid in the normal manner. The steel sheeting is fixed to the purlins, and a ceiling is assumed to be attached directly (or with battens) to the bottom chord.

Note: For design specifications outside the scope of these tables (e.g. cyclonic wind zones) contact your nearest Pryda design office.

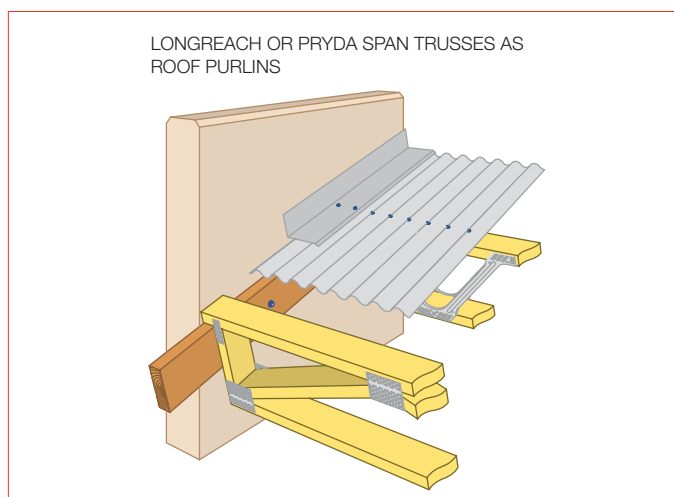

### PRODUCT BENEFITS

Pryda Longreach or Pryda Span trusses are lightweight and easy to handle compared to solid purlins/rafters and this is an advantage when lifting into hard-to-get roof positions.

Longreach can be manufactured to any depth to meet height restrictions or match existing roof features.

The open web truss profile allows mechanical services to pass through while special duct spaces may be incorporated into the profile for larger service pipes and ducts.

Pryda trusses can be manufactured to suit any on-site configuration using the numerous truss end-type details. They may also be designed to incorporate box gutters.

Pryda roof trusses are manufactured in 70mm and 90mm wide timber which improves resistance to buckling under wind loads and reduces the number of required lateral restraints to the bottom chord.

In the same manner as floor trusses, the Pryda Roof System eliminates uneven ceiling levels or complex ceiling support systems and allows a consistent depth throughout the job.



## DESIGN CONSIDERATIONS

### Design Loads

#### Permanent Actions (Dead Loads)

Permanent loads which are considered during the design process include:

Self-weight of truss

Roof material (sheet steel, slate, tile, battens etc)

Ceiling material (plasterboard, battens)

#### Imposed Actions (Live Loads)

Live loads are those associated with non-trafficable roofs and are the result of stacked materials or equipment used in repair and maintenance operations. The minimum imposed actions for roofs stipulated in AS1170.1-2002 is 0.25 kPa on the plan projection of the roof. However, for structures other than houses, this load will increase when the area supported by the truss is less than 14 sqm. The design also considers the concentrated load of a single person standing on the cladding.

### Wind Actions (Wind Loads)

For houses, wind actions are usually obtained from the designated Wind Classifications (N2, N3, C1, C2 etc) for the location of the structure, and based on AS 4055-2006. For commercial structures, wind actions are calculated in accordance with AS1170.2-2011.

### Ducts for Mechanical Services

The span tables list the clear depth between chords if a duct space is made available within the web profile, while also indicating the maximum pipe diameter that may be passed through the webs.

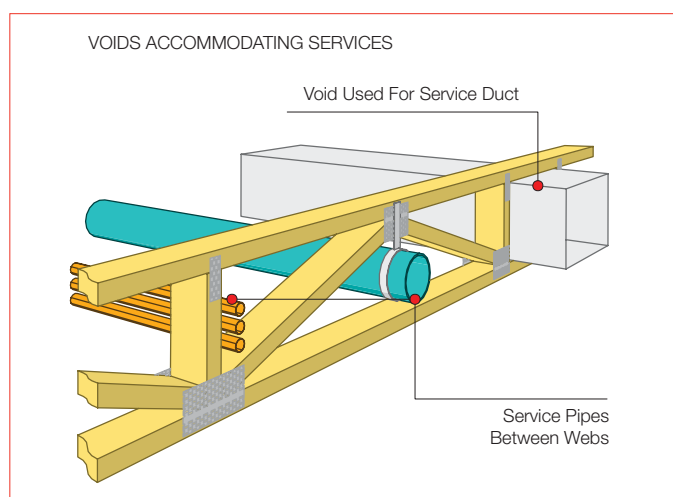

Table 13 – Floor and Rafter Truss Maximum Duct Space

Longreach Floor and Rafter Trusses	Truss Reference	Overall Depth with 2x45mm chords (mm)	Overall Depth with 2x35mm chords (mm)	Clear Depth with 2x35mm chords (mm)	Maximum found duct diameter (mm)	Maximum rectangular opening	
						Height (mm)	Width (mm)
	FT 250	260	240	170	130	170	500
	FT 300	310	290	220	180	220	500
	FT 350	360	340	270	230	270	500
	FT 400	410	390	320	280	320	500
Pryda Span Floor and Rafter Trusses	PS 250	260	240	170	150	170	500
	PS 30	310	290	220	190	220	500
	PS 40	422	N/A	332	260	332	500

## FACTORS AFFECTING PERFORMANCE

The performance of Pryda Rafter Trusses may be limited by a number of factors including deflection under dead load and timber strength capacity under a dead, live or wind actions case.

### Deflection Limits

Longreach and Pryda Span Rafter Trusses are designed according to deflection limits set out in AS1684.1.

Load Condition	Max. Deflection Ratio
Permanent Action	span/300
Imposed Action	span/250
Wind Action	span/150

### Special Loading Conditions

Air conditioning units and other mechanical equipment can add significant loads to rafter trusses. The introduction of an increased truss spacing to incorporate a skylight will also produce a special loading condition. The truss fabricator should be informed of these conditions to accommodate special designs.

## STABILITY

### Top Chord Bracing

The forces generated by resistance to buckling of the top chord and wind loading perpendicular to the span of the trusses must also be transferred back to the supporting structure by steel braces. It is recommended that Pryda Speed Brace or Strap Brace be applied to the top chord in conjunction with adequately spaced roof battens in accordance with AS4440-2004: Installation of Nail-Plated Timber Roof Trusses. The steel brace shall be continuous over the ends of the trusses and be anchored down to the top plate.

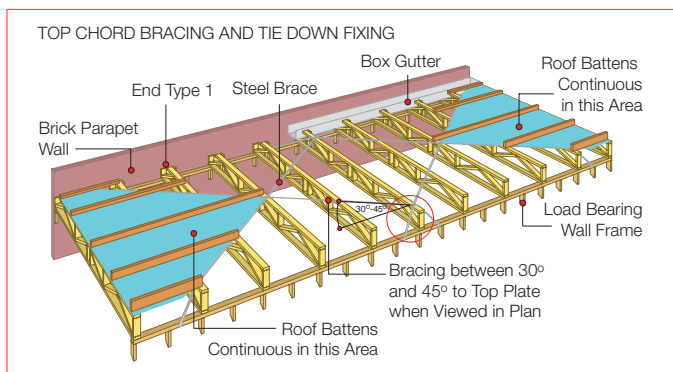

### Bottom Chord Bracing

Strong-Backs are not required for Longreach or Pryda Span roof trusses. For suspended ceilings, or exposed bottom chords, or where ceiling battens do not provide restraint to bottom chords under wind uplift conditions, it is recommended that bottom chord ties are introduced in accordance with AS4440-2004: Installation of Nail-Plated Timber Roof Trusses. In addition to this, Pryda Speed or Strap Braces shall be fixed to the truss bottom chords to transfer bracing loads back to the supporting structure according to AS4440-2004: Installation of Nail-Plated Timber Roof Trusses.

In circumstances where the ceiling material and battens do provide effective restraint then bottom chord ties shall not be required.

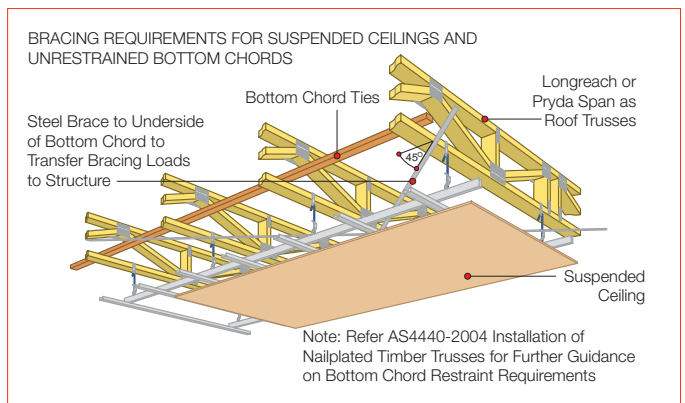

### Cantilever Bracing

Cantilever Bracing Details of Pryda Rafter Truss Systems is as for Pryda Floor Truss Systems. Refer to earlier part of manual and AS4440-2004

### Fixing to Supports

Pryda rafter trusses must be fixed down to the supporting structure using connections that match or exceed the magnitude of the wind uplift forces on each truss. Each truss shall be held onto its supporting plate/bearer by a minimum of 2/75 x 3.15mm skew nails, or one Pryda Minigrip (Product Code: MGS) or Multigrip (Product Code: MG) with 3/35 x 3.15mm nails per tab. Refer to AS1684-2010 for further guidance on fixings and tie down requirements.

Pryda Rafter Trusses shall also be braced laterally at the ends of the trusses using Pryda Strap Brace at each end of a run of trusses.

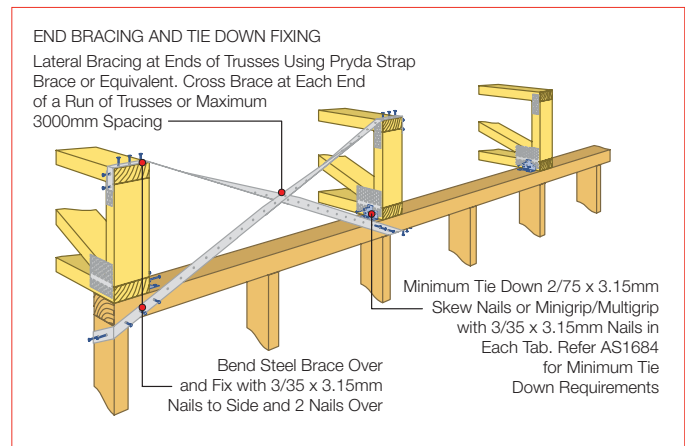

## DETAIL

### End Configurations

The full range of end configurations available to floor trusses may also be incorporated into Longreach and Pryda Span rafter trusses. In addition to this the end configuration may be designed to fit a box gutter or other options as detailed below. These options are available for all truss depths however the dimensions of the box gutter may be limited. Engineering advice should be sought from Pryda.

FLUSH END

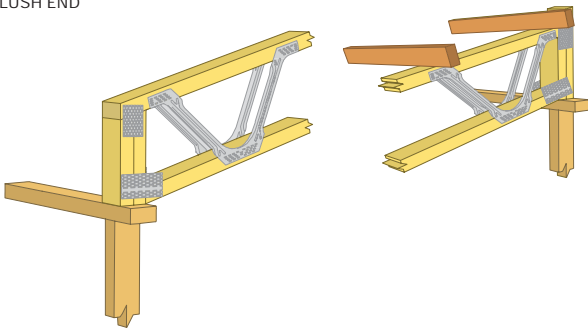

HORIZONTAL SUFFIT OVERHANG

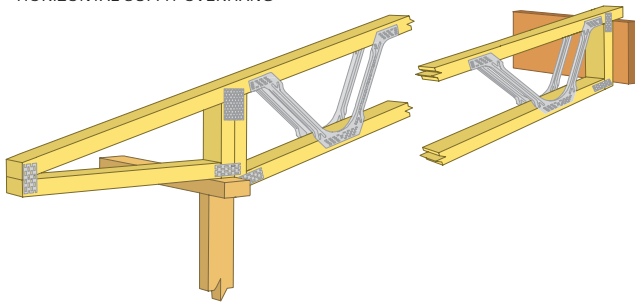

BOX GUTTER AND PARAPET

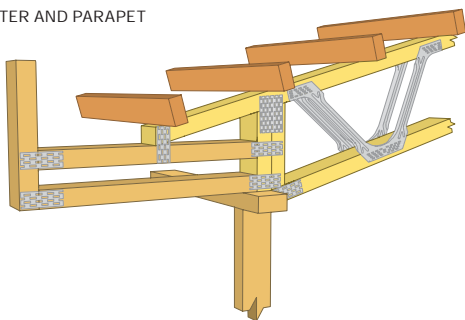

BOX GUTTER

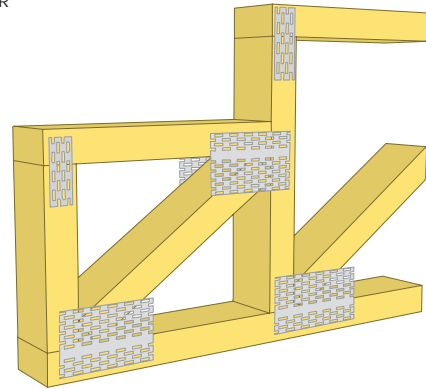

RAKED OVERHANG

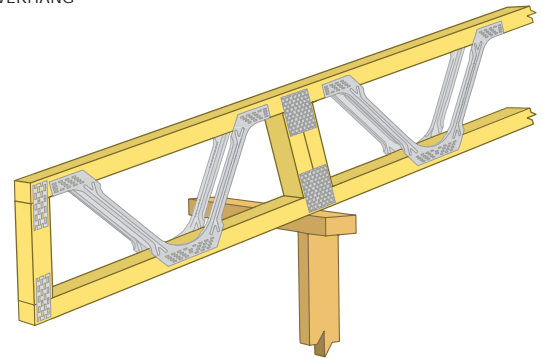

HORIZONTAL SUFFIT OVERHANG

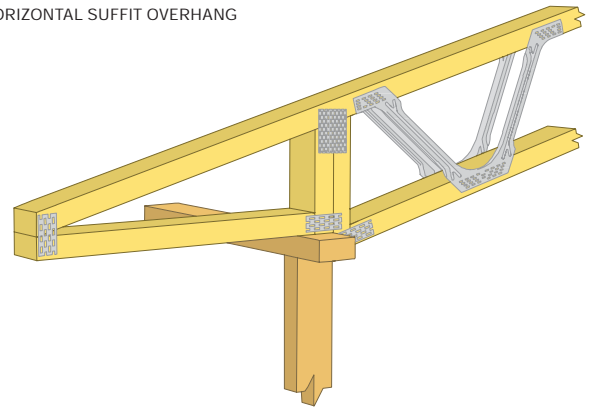

MANSARD EFFECT

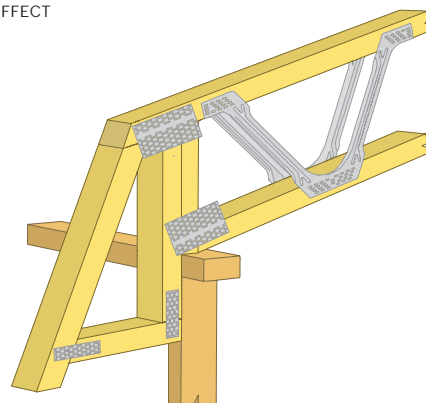

**APPENDICES**

**Appendix A: Producer Statement**

Pryda Australia  
 A division of ITW Australia Pty Ltd Dandenong Ph (03) 9554 7001 Fax 9554 7000

Page 1  
 Date: 11.29am 5-1-2011  
 Ver 3.0.4

**Producer Statement**

**Job Ref: 7889602**

***Floor Truss Design Criteria For Building Permit Application***

**Client Name:** Harry's Homes

**Site Details:** Lot 719, No. 53 Clayton Crescent,  
 Rutherford, NT 0800

**Nominal Design Criteria:**

- Building Importance: Residential
- Flooring: 22mm particieboard
- Ceiling: 10mm plasterboard
- Top chord restraints: 300 mm
- Bottom chord restraints: 600 mm
- Standard truss spacing: 600 mm
- Nominal Floor live loads: 1.50 kPa 1.80 kN
- Floor performance: Nominal

Note: Ceiling lining must be fixed to the bottom chords of trusses with nails or screws at maximum 600mm centres.

The truss designs for this job have been determined using computer software provided by Pryda Australia, using sound and widely accepted engineering principles. In particular, loadings and designs are performed in accordance with the Standards adopted by primary reference in the National Construction Code (NCC 2011), Volume One, A1.3 and Volume Two, Part 1.4.

In addition, the following secondary referenced Australian Standards also apply:

- AS 1649-2001 Timber - Methods of test for mechanical fasteners and connectors - Basic working loads and characteristic strengths
- AS 1684.1-1999 Residential timber - framed construction, Part 1, Design Criteria

All trusses shall be manufactured in accordance with the fabrication specifications provided by Pryda, and installed, connected and braced in accordance with the recommendations given in - : Pryda's Guide to Installation and any other supplementary details that may be provided.

Name: \_\_\_\_\_ Position: \_\_\_\_\_

Signed: \_\_\_\_\_ Date: \_\_\_\_\_

**Producer Statement**

**Job Ref: 7889602**

**Client Name:** Harry's Homes

**Site Details:** Lot 719, No. 53 Clayton Crescent,  
Rutherford, NT 0800

<b>Truss Data</b>	<b>Chords</b>	<b>Webs</b>
Truss Type:	Floor 1. 45MGP10 JD5	Metal PW30
Oall Height:	300 2. 35MGP10 JD5	u.o.n. 35MGP10 JD5
Thickness:	70	
Spacing:	600	
TC Restraint:	300	
Timber Group:	Pine & KD	
Building Importance:	Residential	
Flooring Material:	22mm particleboard	14.8kg
Plus Specified:	3.00kg/sq.m	
Ceiling Material:	10mm plasterboard	7.2kg
Live Load:	1.50 kPa; 1.8 kW	

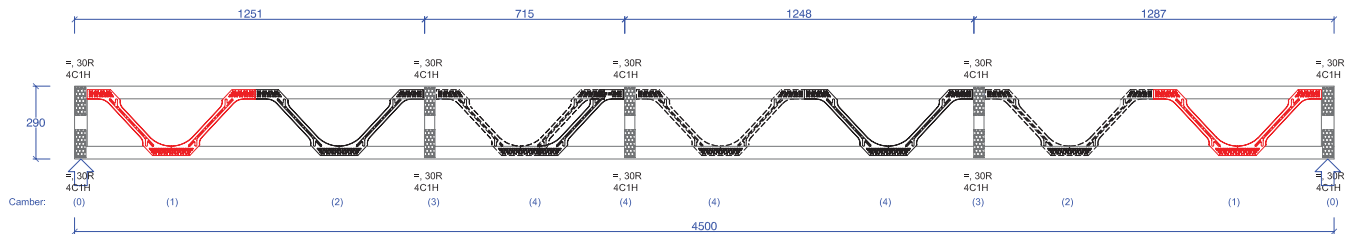

**Truss Mark FT1 > 1 Single Truss**

Appendix B: Typical Layout

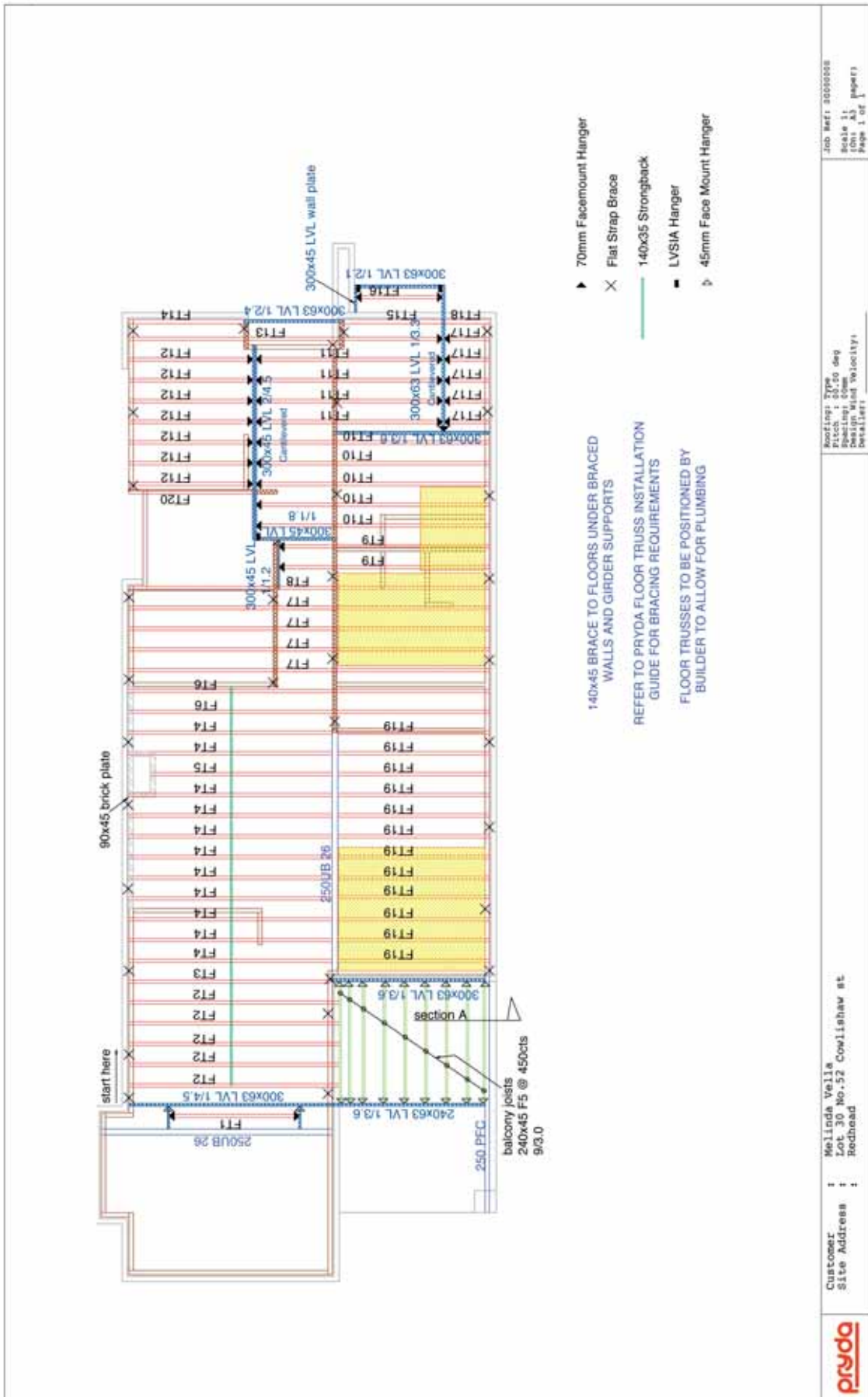

## Appendix C: Detailers Guide / Check List

This is intended to be used as a basic guide only, if in doubt contact an authorized Pryda fabricator or the engineering Department of Pryda Australia

1. Confirm the imposed actions (floor live loads) -uniformly distributed load (kPa) and concentrated load (kN). This is particularly important for commercial jobs
2. Confirm the floor finishes i.e. floor recess in wet areas, shower base, etc.
3. Confirm any additional loads:
  - (a) Kitchen - island benches, stone bench tops etc
  - (b) Wet areas - floor tiles, wall tiles, large baths, spa baths, vanities etc
  - (c) Storage units, book shelves, water beds, pianos, billiard tables etc.
4. Ensure flooring material is adequate to satisfy applied live loads and truss spacing.
 

Note: Generally a warning message will pop-up in Pryda Buildi if the selected flooring material is not suitable.
5. Trusses under walls with wall tiles should be considered
6. Trusses supporting load bearing walls:
  - (a) For walls spanning across trusses– ensure a Critical Vertical Web is provided at this location and the correct point loads are applied.
  - (b) For walls spanning along a truss- ensure correct point loads are applied at every panel point. Double trusses may be considered to satisfy serviceability requirements.
7. A more stringent serviceability requirement may be considered for brittle surfaces such as stone and tiles.
8. Determine location of all critical plumbing services. I.e. toilets, shower drains etc. and ensure trusses are detailed (web profile, truss spacing etc) to accommodate these service pipes.

9. Waling plate design and connections to support trusses must be designed by builder's Consulting Engineer. Seek advice if in doubt. Do not assume nominal fixing of waling plates without considering how the loads are supported.
10. Dynamic performance (spring and bounce) is likely to be increased when floor trusses/joists are supported on structural beams. This aspect must be given consideration.
11. Screw fixing of Strong-Backs to vertical webs is recommended for more consistent performance. Nail fixed Strong-Backs should be tight fitting with no gaps in the connection to the vertical webs.
12. Strongback splice location and methods of connection should be highlighted to ensure correct installation.
13. Solid block or continuous trimmer is to be provided under all concentrated point loads. I.e. jam studs supporting load-bearing lintels and studs supporting concentrated loads.
14. Simplify and rationalize floor truss connections to supporting beams to reduce the risk of errors during installation.
15. Continuous span floor truss will behave much better than single span trusses.
 

When a situation arises where an existing continuous span truss is required to be trimmed back, check the remaining single span for adequate performance. Don't assume the remaining single span will perform correctly
16. Unless specifically required for a particular layout the Pryda Buildi default should be set to "Force diagonal web at Gap" for better truss performance.
17. Floor trusses used in external decking/balcony situations must be fully sealed and made 100% waterproof. If this cannot be achieved then avoid using floor trusses in these areas and substitute with solid joists with the appropriate grade of durability. This should be addressed at the quotation stage.
18. Under no circumstance shall the builder or installer be allowed to modify floor trusses or their connections without prior approval from truss designer or Pryda Engineers.

**Appendix D: Design Request Form**

Design Request Form
---------------------

**Contact Details**

Name			
Address			
Email			
Phone/Fax			

**Site details**

Address			
Email			
Phone/Fax			

**Design Criteria**

Building type	Residential	Commercial	Essential services	Isolated	
Floor performance	Normal	Enhanced	Minimum		
Support types	Masonry	Timber frame	Beams		
Roof material					
Roof pitch					
Roof overhang					
Ceiling material (Upper)					
Flooring material					
Ceiling material (Lower)					
Truss spans					
Floor depth					
Floor cantilever					
Set Down areas					
Exposure to the weather					
Other considerations					

To locate your preferred Pryda fabricator for quotations go to [www.pryda.com.au](http://www.pryda.com.au)

For technical queries please contact Pryda Australia on **1800 810 741**



## Appendix E: Floor Truss Span Tables

### Normal Domestic Loads

#### Pryda Longreach

Imposed Load = 1.5 kPa; 1.8 kN

Permanent Load = approx. 0.5 kPa (varies with flooring type):

Floor Truss ID	Chord Sizes	450 spacing		600 spacing	
		Max Span	Strong-Back	Max Span	Strong-Back
PL25	70x35 MGP10	4400	120x35 F5	3900	120x35 F5
	90x35 MGP10	5000	120x35 F5	4200	120x35 F5
	90x45 F17	5700	120x35 P10	5500	140x35 P10
PL30	70x35 MGP10	5000	140x35 F5	4200	140x35 F5
	90x35 MGP10	5500	140x35 F5	4400	140x35 F5
	90x45 F17	6300	140x35 F5	6100	140x35 P10
PL35	70x35 MGP10	5400	140x35 F5	4700	140x35 F5
	90x35 MGP10	6000	140x35 F5	5200	140x35 F5
	90x45 F17	6900	140x35 F5	6600	140x35 P10
PL40	70x35 MGP10	5800	140x35 F5	5100	140x35 F5
	90x35 MGP10	6400	140x35 F5	5400	140x35 F5
	90x45 F17	7400	140x35 F5	7200	140x35 P12

Note:

- (i) Floor Truss spacing of 450 assumes 19mm particleboard flooring and spacing of 600 assumes 22mm particleboard flooring.
- (ii) Strong-Backs are NOT required for truss spans less than 3500mm. Read section on Strong-Backs for further details.
- (iii) It is assumed that no specific 'duct spaces' are provided along the span of truss.

#### Pryda Span

Imposed Load = 1.5 kPa; 1.8 kN

Permanent Load = approx. 0.5 kPa (varies with flooring type):

Permanent Component of Live Load = 0.5 kPa

Floor Truss ID	Chord Sizes	450 spacing		600 spacing	
		Max Span	Strong-Back	Max Span	Strong-Back
PS25	70x35 MGP10 <sup>(iv)</sup>	4300	120x35 F5	3900	120x35 F5
	90x35 MGP10	4800	120x35 F5	4200	120x35 F5
	90x45 F17	6000	120x35 P10	5200	140x35 P10
PS30	70x35 MGP10 <sup>(iv)</sup>	4800	140x35 F5	4100	140x35 F5
	90x35 MGP10	5400	140x35 F5	4500	140x35 F5
	90x45 F17	6300	140x35 F5	5800	140x35 P10
PS40	70x35 MGP10	N/S	-	N/S	-
	90x35 MGP10	N/S	-	N/S	-
	90x45 F17	6900	140x35 F5	6600	140x35 P10

Note:

- (i) Floor Truss spacing of 450 assumes 19mm particleboard flooring and spacing of 600 assumes 22mm particleboard flooring.
- (ii) Strong-Backs are NOT required for truss spans less than 3500mm. Read section on Strong-Backs for further details.
- (iii) Nominal floor truss depths vary with chord sizes. For 35mm chords; PS25 = 240mm, PS30 = 290mm and for 45 chords; PS25 = 260mm, PS30 = 310mm and PS40 = 422mm. Note: PS40 only uses 45mm chord.
- (iv) A 70x35 MGP12 top chord is required to resist concentrated load effects.

## Commercial Office Loads

### Pryda Longreach

Dead Load = Nominal +0.50 kPa, Live Load = 3.0 kPa; 2.7 kN;  
Truss Spacing = 450 c/c

Floor Truss ID	Chord Sizes	Max Span for 450 c/c
PL25/3	90x35 MGP10	2800
	90x45 MGP12	4900
	90x45 F17	5200
PL30/3	90x35 MGP10	3900
	90x45 MGP12	5600
	90x45 F17	5800
PL35/3	90x35 MGP10	4200
	90x45 MGP12	6300
	90x45 F17	6400
PL40/3	90x35 MGP10	4600
	90x45 MGP12	6800
	90x45 F17	6900
PL45/3	90x35 MGP10	4900
	90x45 MGP12	7300
	90x45 F17	7500

(i) Assumes 22mm particleboard flooring, using 565mm standard web lengths

### Pryda Span

Dead Load = Nominal +0.50 kPa, Live Load = 3.0 kPa; 2.7 kN;  
Truss Spacing = 450 c/c

Floor Truss ID	Chord Sizes	Max Span for 450 c/c
PL25/3	90x35 MGP10	2500
	90x45 MGP12	4600
	90x45 F17	4800
PL30/3	90x35 MGP10	3600
	90x45 MGP12	5300
	90x45 F17	5500
PL35/3	90x35 MGP10	N/S
	90x45 MGP12	6300
	90x45 F17	6300

## Notes: Floor Truss Span Tables

i. **Nominal Permanent Loads** - The span tables provided in the following pages are based on a nominal permanent load of approximately 0.25 kPa to 0.35 kPa. This takes into account the weight of flooring material, ceiling material, light weight floor coverings like carpets and any insulation. Some examples are given below for easy understanding.

Ex1: 19mm particleboard as flooring material	= 13.2 kg/m <sup>2</sup>
10mm plasterboard as ceiling material	= 7.2 kg/m <sup>2</sup>
Carpets as floor covering	= 3.0 kg/m <sup>2</sup>
Any insulation	= 1.0 kg/m <sup>2</sup>
TOTAL	= 24.4 kg/m <sup>2</sup> = <b>0.24 kPa</b>
Ex2: 22mm particleboard as flooring material	= 14.8 kg/m <sup>2</sup>
13mm plasterboard as ceiling material	= 8.5 kg/m <sup>2</sup>
12mm timber as floor covering	= 7.0 kg/m <sup>2</sup>
Any insulation	= 1.0 kg/sqm <sup>2</sup>
TOTAL	= 31.3 kg/m <sup>2</sup> = <b>0.31 kPa</b>

The self weight of the floor truss itself is considered separately in the design, and is not part of the 0.40 kPa indicated here. Note: In addition to the dead loads, a permanent component of the imposed (live) load of 0.50 kPa is also considered in the design.

- ii. **Flooring Material** – 19mm particleboard for 450 c/c and 22mm particleboard for 600 c/c are assumed as the flooring material supporting domestic loads. And, 22mm particleboard flooring is assumed for office loads at 450 truss spacing.
- iii. **Strong-Backs** – are not required for truss spans less than 3500mm. *Read the section on Strong-Backs for further details.*
- iv. **Duct Spaces** – the design assumes that ducts and pipes are taken through the natural gaps in the truss, and no specific duct spaces are provided. *If duct spaces are required, the truss manufacturer should be informed at the design stage with specific size and locations. Accordingly, the maximum spans given here may get reduced slightly.*
- v. **Top Chord Panel Lengths** – it is assumed that standard 565mm lengths are used for diagonal webs. *The top chord panel lengths would then vary with changing truss depth. This is of particular importance to floor trusses in commercial jobs with large concentrated loads.*
- vi. **Dynamic Performance** – the maximum spans in the given span tables are generated for 'normal' conditions, meaning that the natural frequency is maintained at a minimum 8.0 Hz. *The performance of the floor is also influenced by many other factors, and for further details read the note on the subject in pages 12 and 13*

#### Special Note:

*The above tables are intended as a guide only. The final design of trusses will be carried out by a Pryda Truss Manufacturer for a given project using proprietary software developed by Pryda Australia.*

## Appendix F: Rafter or Purlin Truss Span Tables

### Normal Domestic Loads

#### Pryda Span

Roofing = Steel Sheet; Truss Spacing = 900 mm

Roof Truss ID	Chord Sizes	Max Span	
		Wind N2	Wind N3
PS25	90 x 35 MGP10 <sup>(i)</sup>	6500	4800
	90 x 45 F17 <sup>(iii)</sup>	9200	9200
PS30	90 x 35 MGP10 <sup>(i)</sup>	7300	5700
	90 x 45 F17 <sup>(iii)</sup>	10000	10000
PS40	90 x 35 MGP10	9300	8000
	90 x 45 F17 <sup>(iii)</sup>	12000	12000

### Commercial Building Loads

#### Pryda Span

Roof Truss ID	Chord Sizes	Max Span	
		Vu = 40 m/s	Vu = 50 m/s
PS25	90 x 35 MGP12	5700	5500
	90 x 45 F17 <sup>(iii)</sup>	9200	9200
PS30	90 x 35 MGP12	6700	6300
	90 x 45 F17 <sup>(iii)</sup>	10000	10000
PS40	90 x 45 MGP10	6500	6500
	90 x 45 F17 <sup>(iii)</sup>	12000	12000

#### Notes: Rafter or Purlin Truss Span Tables

- i. Chord sizes here refers to both top and bottom chords. However a 90x35 MGP12 bottom chord may be required in some instances to achieve above maximum spans.
- ii. The above values are based on a maximum roof pitch of 10 degrees. Larger maximum spans may be achieved at roof pitches greater than 10 degrees.
- iii. The maximum spans for 90x45 F17 chords are limited by dead load deflection set at a maximum 25mm.
- iv. The maximum spans are valid for rafter trusses (all areas) and purlin trusses that occur in general areas only. They are not applicable for purlin trusses close to roof edges as defined in AS1684 and AS/NZS 1170.2.
- v. **Lateral Restraints** – the top chord assumes restraints at maximum 1200mm c/c provided by roof battens (rafter trusses) or top chord ties (purlin trusses). The bottom chords assume restraint spacing equal to a maximum 1800mm c/c. In some instances the above spans (for the given chord sizes) could be achieved using lateral restraint spacing greater than 1200mm(TC) or 1800mm(BC), provided designs are verified using Pryda's proprietary software.
- vi. A moving point load of 1.4 kN is applied on the top chord of truss for Commercial Buildings, and hence the need for a minimum 90x35 MGP12 (or 90x45 MGP10) as chords. Note: Vu refers to ultimate design wind speed.
- vii. Contact a Pryda Design Office or a Pryda Truss Manufacturer for advice on situations outside the scope of the above tables.

### Appendix G: Impact of Higher Permanent (Dead) Loads

Additional permanent loads from bathrooms, kitchens etc are inevitable in any house floor plan. The following curves illustrate the impact of these additional loads in comparison with nominal permanent loads. As the dynamic performance and the natural frequencies are affected by increasing permanent loads, the curves also provide a good understanding of how natural frequencies vary with span and permanent loads. Note: Only the most common timbers (35 x 90 MGP10) and spacing (450 c/c) are used in these illustrations.

For 35x90 MGP10 chords; 450 c/c

Truss ID	Perm Load	Max Spans	Frequency at Max Span (Hz)
PL30	0.30 kPa	5500	9.3
	0.80 kPa	5000	8.6
	1.30 kPa	4600	8.5
PL35	0.30 kPa	6000	9.3
	0.80 kPa	5000	8.4
	1.30 kPa	5000	8.6
PL40	0.30 kPa	6400	9.4
	0.80 kPa	5900	8.5
	1.30 kPa	5500	8.2

#### Variation of Frequency with span for increased dead loads

-for PL30 (300 deep) floor truss with 35x90 MGP10 chords at 450 c/c

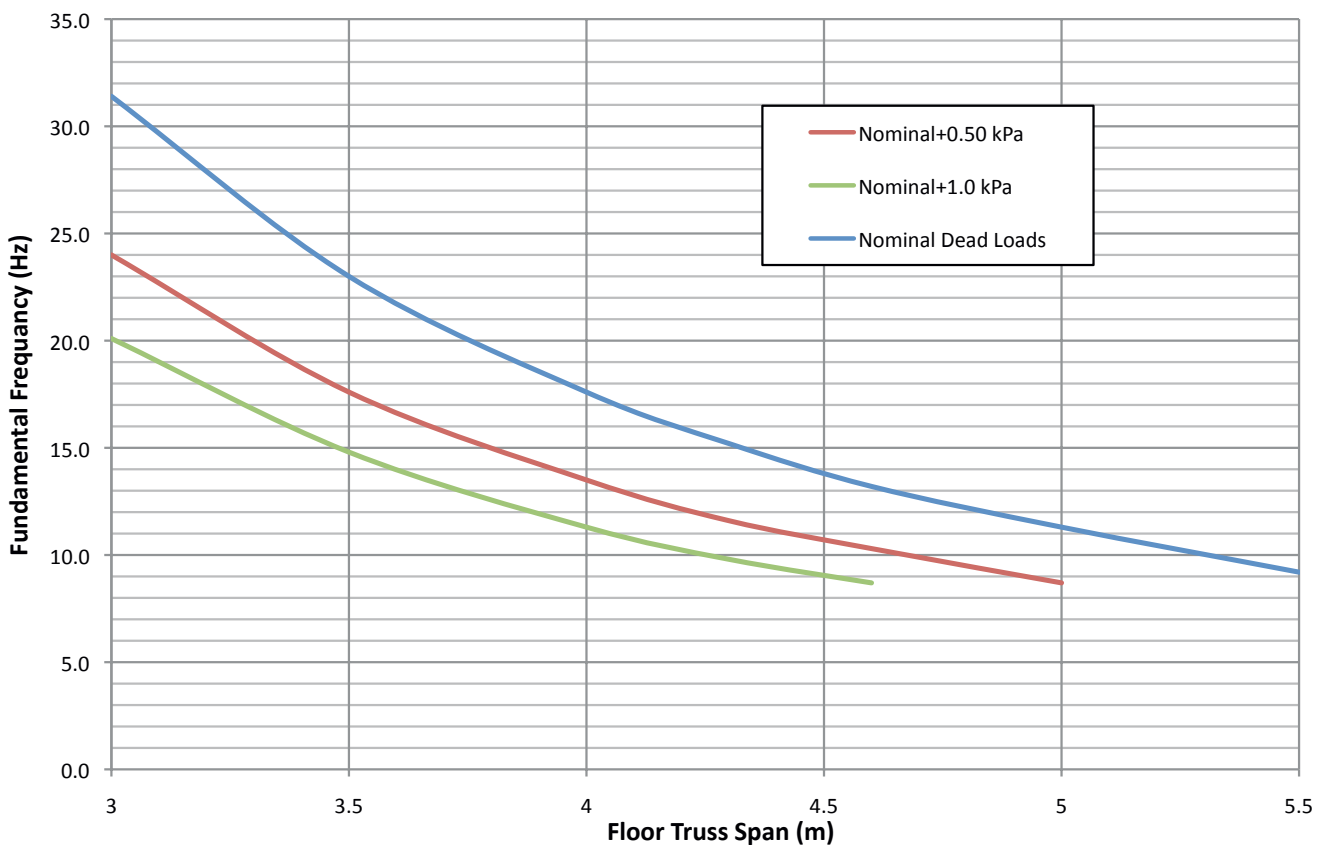

### Variation of Frequency with span for increased dead loads

-for PL35 (350 deep) floor truss with 35x90 MGP10 chords at 450 c/c

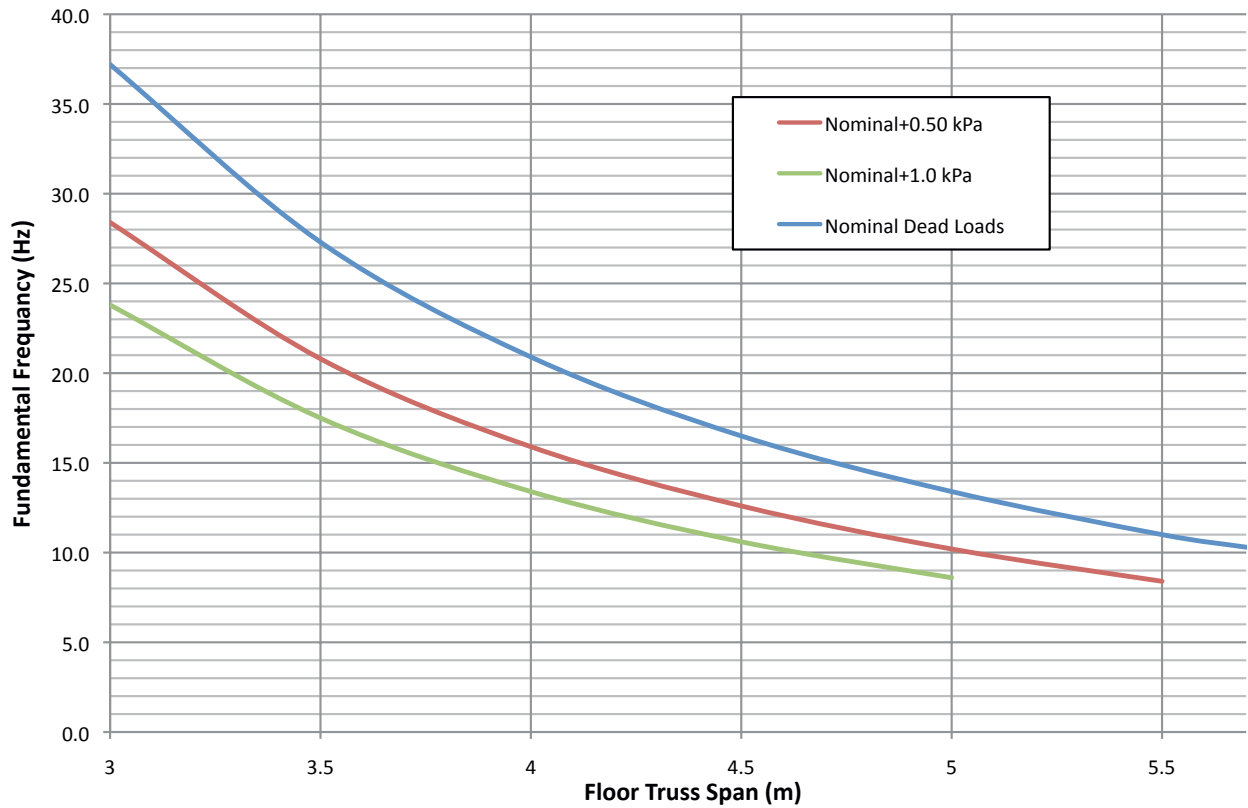

### Variation of Frequency with span for increased dead loads

-for PL40 (400 deep) floor truss with 35x90 MGP10 chords at 450 c/c

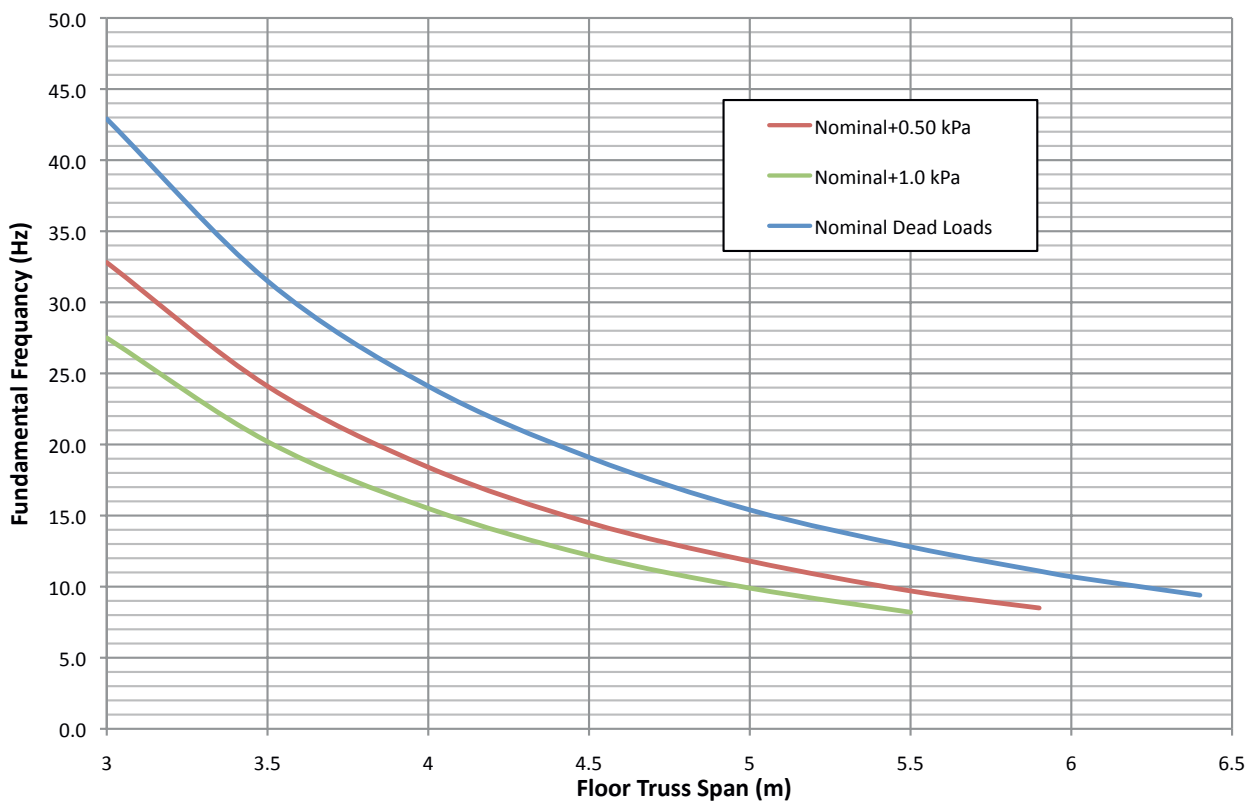





## Contact Pryda

All enquiries to Melbourne Head Office

### Melbourne (Head Office)

2-10 Nina Link, Dandenong South, Victoria 3175 Australia.

**Tel:** 1800 810 741

**Fax:** 1300 657 054

**Email:** [info@pryda.com.au](mailto:info@pryda.com.au)