

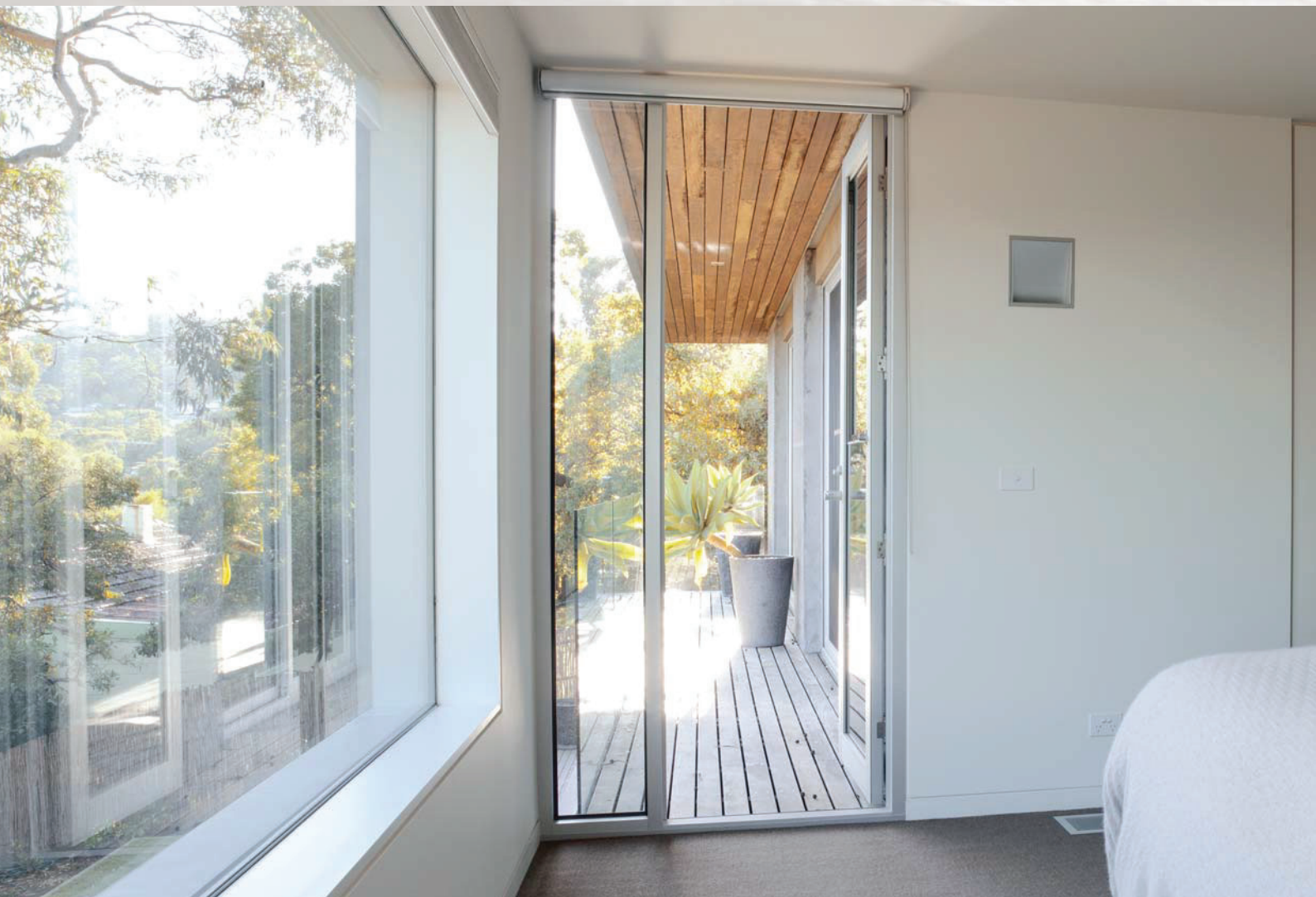

The AGS Range 225 Series Door



The AGS Series range of entry doors are designed to achieve the ultimate combination of architectural style and performance. Each door is engineered to withstand Australia's harsh conditions. In fact, they're recognised as some of the best performing doors on the market, all tested for heavy use commercial and residential applications.

The AGS 225 Series Door

The AGS 225 Door is a 46mm pocket glazed commercial door panel capable of hinge, pivot and sliding door configurations, and has been designed with flexibility, performance and ease of assembly in mind. The AGS 225 Door builds on the trusted and reliable 200 and 275 Series Doors, suiting a wide range of applications from architectural entry doors through to commercial shopfronts.

The AGS 225 Door can be fitted with either single or double glazed units and has the option of standard and wide stiles. It is also compatible with a vast range of commercial and architectural locks and furniture as well as the full range of Capral framing systems.

Features and Benefits:

- 46mm Door Panel
- Narrow and wide stile options accommodate a range of hardware
- Shallow rail option
- Suits both single and double glazing
- Hinged, french, pivot and sliding door panel configurations
- Suits commercial or architectural applications
- Compatible with a wide range of framing suites
- Open in and open out configurations

Finishes Available:



Powder coated range



Anodised Aluminium



Woodgrain



Configurations

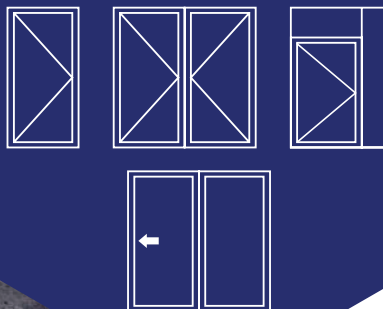

Maximum Recommended Sash Sizes

Door	Height	Width
Hinged	3000mm	1200mm
Pivot	3000mm	1200mm
Sliding	2700mm	1800mm

Door Panel Size

Depth	46mm
-------	------

Maximum Product Performance

SLS (Pa)	up to 4500Pa
ULS (Pa)	up to 10,000Pa
WATER (Pa)	Open Out: up to 900Pa Open In: up to 300Pa

Maximum Acoustic Rating

Rw	36
C;CTR	-1;-2

Glazing Details

Single Glazed	4mm - 12mm
Thick Glazed	14mm - 18mm
Double Glazed	19mm - 31mm

Compatible with

AGS Commercial Range



CAPRAL
ALUMINIUM

1800 ALUMINIUM (258 646)

www.capral.com.au

Capral Limited ABN 78 004 213 692 | November 2017

Technical Manual History

The table below is a summary of this manual's update history. Contact Capral for details of past updates.

RELEASE DATE	UPDATE SUMMARY
01-07-2018	First Release (Manual split from 215 hinged Door)
01-11-2018	General Updates. Component replaced. Pivot Min Height reduced. Lock, Jacking Screw & COC Pivot Clarified.
01-11-2019	General Updates
01-11-2020	Product Upgrade

The table below shows the details of the latest manual update.

MANUAL RELEASE – 01-08-2021	
DESCRIPTION	AFFECTED PAGES
Cyclonic Impact test report summary added	8.36-38
Cyclic test report summary added	8.39-40

Technical Manual History

IMPORTANT CONDITIONS

By using this manual you agree to the following:

DISCLAIMER

Whilst best efforts have been made to ensure the details contained herein are accurate and correct, Capral is not responsible for any loss or damage whatsoever arising as a result of any errors contained in this manual. Interpretation of standards or codes within this manual is Capral's interpretation of such codes. Responsibility for code compliance remains with the user of this manual. In some cases product specifications may vary without notice. Users should not act or rely upon any information contained in this manual without obtaining appropriate professional advice relating to their particular circumstances. To the maximum extent permitted by law Capral disclaims all liability for loss or damage suffered by anyone who acts or fails to act in reliance of this manual.

COPYRIGHT

This manual remains the property of Capral and contains information which is the subject of copyright. The manual or any part of it may not be reproduced, copied or loaned in any form without the prior written permission of Capral. The manual is to be returned to Capral on request.

CAPRAL SUPPLY TERMS

Refer to www.capral.com.au/Terms-of-Trade for Capral's Terms and Conditions of Sale for terms of supply by Capral of its products.

Index

SPECIFICATIONS		Section 1
Size Limitations		1
Performance		1
EXTRUSIONS		Section 2
Extrusions		1 - 10
Extrusion Data		11 - 13
COMPONENTS		Section 3
Glazing Details		1
Door Rebate Table		2
Components		3 - 12
Lock Fitment Table		13
CUTTING FORMULAS & BOMs		Section 4
Cutting Formula & BOM – Door Panel		1 - 2
Cutting Formula & BOM – Slat Panel		3
Cutting Formula & BOM – Louvre Panel		4
Cutting Formula & BOM – Hinged Door		5 - 7
Cutting Formula & BOM – Pivot Door		8
Cutting Formula & BOM – Basic Sliding Door		9
Cutting Formula & BOM – Double Track Sliding Door		10
Cutting Formula & BOM – Flushline Sliding Door		11- 12
MACHINING DETAILS		Section 5
Machining – Door Stop Head Option 1 - Notched		1
Machining – Door Stop Head Option 2 - Mitred		2
Machining – Door Stop Thresholds		3
Machining – Thresholds		4
Machining – Panel Drainage & 50mm Midrail		5
Machining – Jacking Screws & Thick Glass Adaptor		6
Machining – Spigots		7
Machining – Cover Stiles		8
Machining – Hinges		9 - 11
Machining – Concealed Overhead Closer		12 - 16
Machining – 1030 & 1031 Rollers		17
Machining – 1021 & 1022 Rollers & Guide Buttons		18
Machining – Flush Bolt		19
Machining – Optimum Lock		20
Machining – Optimum Lock Strikes		21
Machining – Selector Lock		22
Machining – 3541 Mortice Lock		23
Machining – Selector & 3541 Mortice Lock Strikes		24
Machining – Pull Handles		25
Machining – 1061 Track, Bracket & Cover Plate		26
Machining – 3570 Mortice Lock		27

Index

MACHINING DETAILS Cont.		Section 5
Machining – LCL Lock		28
Machining – Electric Strike & Power Transfer Device		29
Machining – Louvre Panel		30
Machining – Door Closers		31 – 38
ASSEMBLY		Section 6
Assembly – Euro Bracket & Jacking Screw Panel		1
Assembly – Euro Bracket		2
Assembly – Spigot & Block Glazing Panel		3
Assembly – Spigot Kits & Tie Rod		4
Assembly – 110mm & Coupled Midrails		5
Assembly – 50mm Midrail		6
Assembly – Aluminium Slat Panel		7
Assembly – Louvre Panel & Finger Pull		8
Assembly – Rollers		9
Assembly – Flush Bolt		10
Assembly – Meeting Panel & Flush Bolt Guide Seal		11
Assembly – 3570 Mortice Lock		12
Assembly – Optimum & LCL Lock		13
Assembly – Selector & 3541 Mortice Locks		14
Assembly – G Pull Handle		15
Assembly – Door Stops		16
Assembly – Concealed Overhead Closer		17 - 18
Assembly – Open Out Arm Door Closer		19
Assembly – Open Out Slide Track Door Closer		20
Assembly – Open In Door Closers		21
ARRANGEMENTS		Section 7
Configurations		1
Door Panel		
Arrangement – Euro Bracket / Jacking Screw Glazing Panel		2
Arrangement – Spigot / Block Glazing Panel		3
Arrangement – Tie Rod / Block Glazing Panel		4
Arrangement – Midrails		5 - 6
Arrangement – Louvre Panel		7
Arrangement – Aluminium Slat Panel		8
Hinged Door		
Vertical Arrangement 01 & 03 – 76mm Open Out Hinged Door		9
Vertical Arrangement 01 & 03 – 76mm Open In Hinged Door		10
Vertical Arrangement 01 & 03 – 101.6mm Open Out Hinged Door		11
Vertical Arrangement 01 & 03 – 101.6mm Open In Hinged Door		12
Vertical Arrangement 01 – Alt. Hinged Door Frames		13 - 14
Vertical Arrangement 03 – Alt. Hinged Door Sills		15 - 16
Horizontal Arrangement 06 & 07 – Open Out Hinged Door		17
Horizontal Arrangement 06 & 07 – Open In Hinged Door		18
Horizontal Arrangement 08 – Double Hinged Door Meeting Stiles		19

Index

ARRANGEMENT DETAILS		Section 7
Pivot Door		
Vertical Arrangement 01 & 03 – Pivot Head & Sill		20 - 21
Vertical Arrangement 04 – Alt. Pivot Head/Transoms		22
Horizontal Arrangement 06, 07 & 08 – Pivot Jambs & Meeting Stiles		23
Basic Sliding Door		
Vertical Arrangement 01 & 03 – 1022 & 1021 Sliding Floor Tracks		24
Vertical Arrangement 01 & 03 – 1030 & 1031 Sliding Head tracks		25
Vertical Arrangement 01 & 03 – 1061 Sliding Head Track		26
Horizontal Arrangement 06 & 07 – Sliding Jambs & Interlocks		27
Horizontal Arrangement 08 – Sliding Meeting Stiles		28
Double Sliding Door		
Vertical Arrangement 04 & 05 – Double Head & Floor track		29
Horizontal Arrangement 07, 08 & 09 – XXO Jambs & Interlocks		30
Horizontal Arrangement 07 & 08 – XX Jambs & Interlock		31
Flushline Sliding Door		
Vertical Arrangement 04 & 05 – Flushline Sliding Panel		32
Vertical Arrangement 04 & 05 – Flushline Fixed Panel		33
Horizontal Arrangement 07, 08 & 09 – Flushline Jambs & Interlock		34
Automatic Sliding Door		
Vertical Arrangement 01 & 03 – Single Automatic Door Head & Sill		35
Vertical Arrangement 04 & 05 – Double Automatic Door Head & Sill		36
Horizontal Arrangement 06 & 07 – Automatic Jambs & Interlock		37
Vertical Arrangement– Drop Seals		38
TESTING		Section 8
Structural & Water Test Report Summaries – D & DD		1 - 35
Cyclonic Impact Test Report Summaries – D		36 - 38
Cyclic Test Report Summaries – D		39 - 40
Bushfire Test Report Summary 44400500.1 – D		41 - 42
Acoustic Test Report Summaries – D		43 - 46
SPAN TABLES		Section 9
Span Table – Lock Stile EP14647		1 - 2
Span Table – Wide Lock Stile EP14988		3 - 4
Span Table – Meeting Stiles EP14649/EP14649		5 - 6
Span Table – Cover Stiles EP17134/EP14647		7 - 8
Span Table – Wide Cover Stiles EP14647 & EP14988/EP18500		9 - 11
Span Table – Pivot Meeting Stiles EP14647/EP14647		12
Span Table – Wiper Stile EP14960		13
Span Table – Wide Wiper Stile EP14984		14
Span Table – Sliding Meeting Stiles EP17134 / EP14647		15
Span Table – Coupled Midrails		16 - 21
Span Table – 110mm Midrail EP14908		22
Span Table – 50mm Midrails		23 - 25
Span Table – Aluminium Slats		26
Maximum Glass Thickness Tables - Midrails		27 - 31

Product Specifications

SIZE LIMITATIONS: HINGED DOOR

Panel Height
 Minimum: 1600mm
 Maximum: 3000mm

Panel Width
 Minimum: 600mm
 Maximum: 1200mm (315483 Euro Bracket)
 1500mm (322182 / 322183 Spigot)

Panel Area
 Maximum: 3.6m² (315483 Euro Bracket)
 Maximum: 3.8m² (322182 / 322183 Spigot)

Panel Weight
 Refer to Hinge Capacity.

SIZE LIMITATIONS: PIVOT DOOR

Panel Height
 Minimum: 1600 mm
 Maximum: 3000mm

Panel Width
 Minimum: 600mm
 Maximum: 1200mm

Panel Weight
 Refer to Pivot Capacity.

SIZE LIMITATIONS: SLIDING DOOR

Panel Height
 Minimum: 1600mm
 Maximum: 2700mm

Panel Width
 Minimum: 750mm
 Maximum: 1800mm

Panel Weight
 Refer to Roller Capacity.

NOTE: Refer to the information below & Span Tables to check the maximum sizes that can be achieved for the assigned performance requirements of the installation.

SERVICEABILITY PRESSURE & WATER PERFORMANCE

The Serviceability Pressures listed in the Span Tables have not been limited by a water performance. Where water performance is necessary the product should be limited to the following maximum water ratings or serviceability pressures:

Configuration	Sill	Transom	Max. Water Rating (Pa)	Max. Serviceability Pressure (Pa) (Max. Water Rating / 30%)
DD Open Out	EP13539	N/A	150	500
	EP2365	N/A	150	500
	EP2366 / EP5693	N/A	600	2000
D Open Out	EP2365	N/A	150	500
	EP2366 / EP5693	N/A	900	3000
	EP13539	N/A	150	500
D Open In	EP2365	N/A	150	500
	EP15939 / EP5693	N/A	300	1000
	EP15939	N/A	150	500
DD Open In	EP15939	N/A	150	500
	EP15939 / EP5693	N/A	200	666

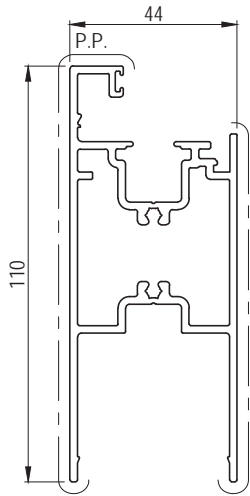

EP18288
SG RAIL
Paint Perimeter: 345mm
Anodised Perimeter: 518mm

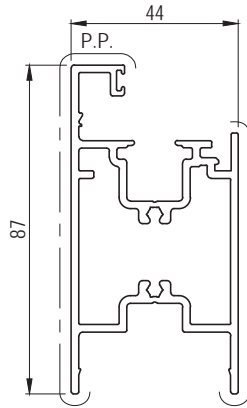

EP18289
SG SHALLOW RAIL
Paint Perimeter: 284mm
Anodised Perimeter: 525mm

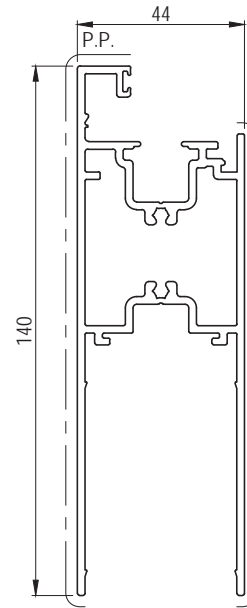

EP18354
SG EXTENDED RAIL
Paint Perimeter: 439mm
Anodised Perimeter: 658mm

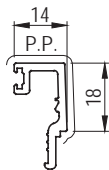

EPD0223
SG & TG BEAD
Paint Perimeter: 100mm
Anodised Perimeter: 100mm

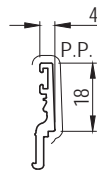

EPD0224
DG BEAD
Paint Perimeter: 100mm
Anodised Perimeter: 100mm

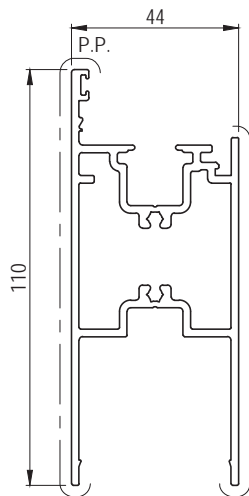

EP18287
DG RAIL
Paint Perimeter: 325mm
Anodised Perimeter: 487mm

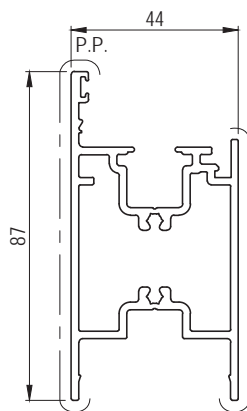

EP18286
DG SHALLOW RAIL
Paint Perimeter: 264mm
Anodised Perimeter: 395mm

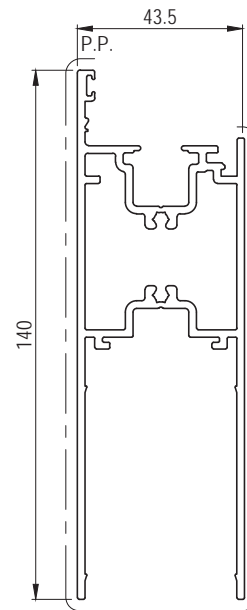

EP18353
DG EXTENDED RAIL
Paint Perimeter: 418mm
Anodised Perimeter: 627mm

Please read in conjunction with Important Conditions – Index (also available on Capral website)

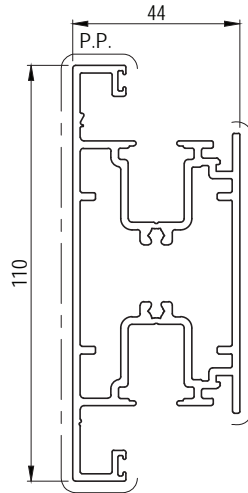

EP18269
SG MIDRAIL
Paint Perimeter: 376mm
Anodised Perimeter: 564mm

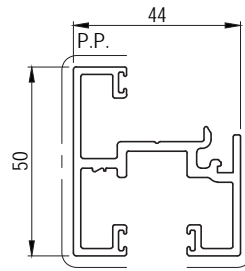

EP17152
SG 50mm MIDRAIL
Paint Perimeter: 281mm
Anodised Perimeter: 421mm

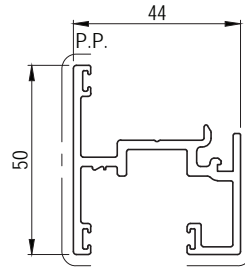

EP17153
TG 50mm MIDRAIL
Paint Perimeter: 240mm
Anodised Perimeter: 360mm

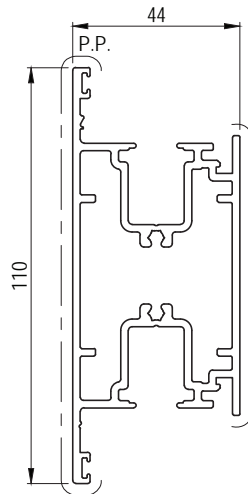

EP18270
DG MIDRAIL
Paint Perimeter: 335mm
Anodised Perimeter: 502mm

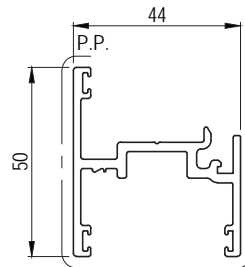

EP17154
DG 50mm MIDRAIL
Paint Perimeter: 219mm
Anodised Perimeter: 328mm

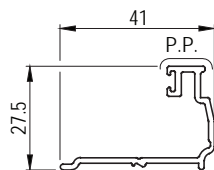

EP14925
THICK GLASS ADAPTOR
Paint Perimeter: 118mm
Anodised Perimeter: 177mm

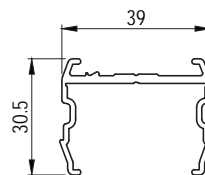

EP16765
MIDRAIL COUPLER
Paint Perimeter: NA
Anodised Perimeter: 224mm

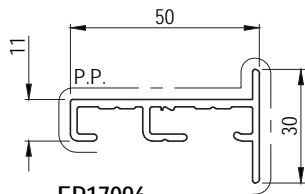

EP17096
LOUVRE ADAPTOR
 Paint Perimeter: 156mm
 Anodised Perimeter: 233mm

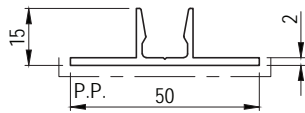

EN3597
RAIL LOUVRE ADAPTOR
 Paint Perimeter: 100mm
 Anodised Perimeter: 155mm

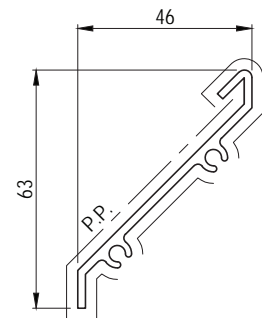

EL2096
63 x 46mm BLADE
 Paint Perimeter: 171mm
 Anodised Perimeter: 217mm

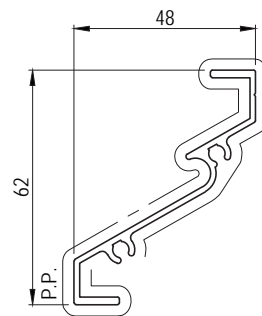

EN4023
62 x 48mm THROATED BLADE
 Paint Perimeter: 182mm
 Anodised Perimeter: 258mm



EPD0121
PANEL 92 x 12mm
 Paint Perimeter: 213mm
 Anodised Perimeter: 242mm



EPD0217
PANEL 100 x 12mm
 Paint Perimeter: 250mm
 Anodised Perimeter: 258mm

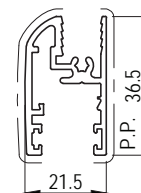

EPD0122
PANEL GLAZING FRAME
 Paint Perimeter: 127mm
 Anodised Perimeter: 272mm

Extrusions

Scale 1:2

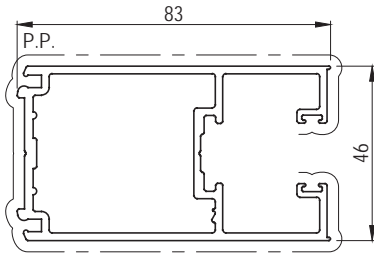

EP14988
SG WIDE LOCK STILE
Paint Perimeter: 361mm
Anodised Perimeter: 537mm

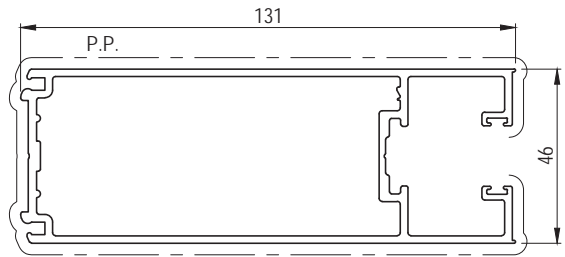

EP14647
SG LOCK STILE
Paint Perimeter: 294mm
Anodised Perimeter: 441mm

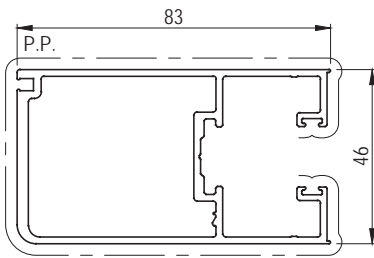

EP14986
SG WIDE RADIUS STILE
Paint Perimeter: 349mm
Anodised Perimeter: 523mm

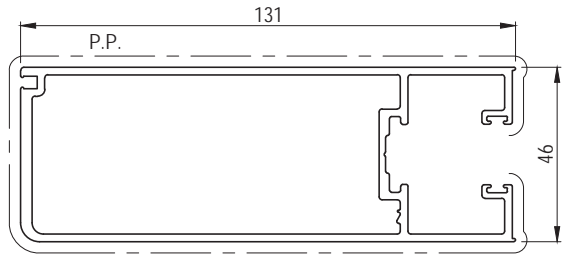

EP14648
SG RADIUS STILE
Paint Perimeter: 286mm
Anodised Perimeter: 428mm

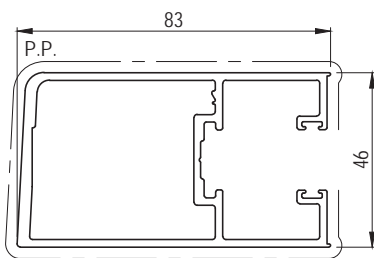

EP16976
SG WIDE BEVEL STILE
Paint Perimeter: 341mm
Anodised Perimeter: 511mm

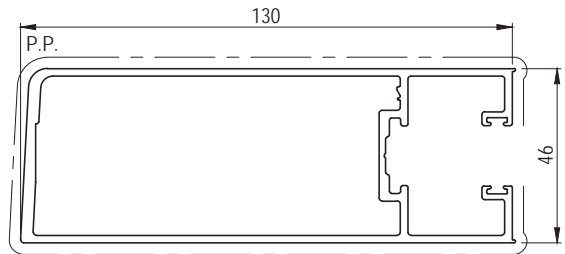

EP16977
SG BEVEL STILE
Paint Perimeter: 277mm
Anodised Perimeter: 415mm

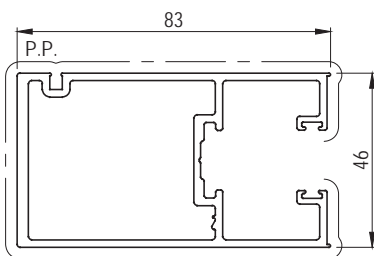

EP14984
SG WIDE WIPER STILE
Paint Perimeter: 349mm
Anodised Perimeter: 524mm

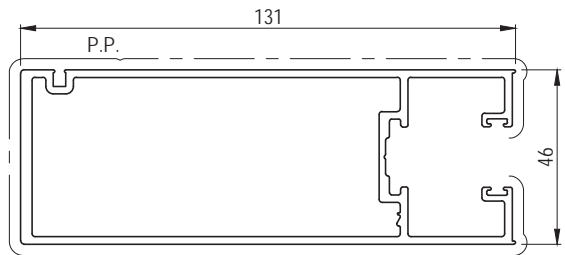

EP14960
SG WIPER STILE
Paint Perimeter: 285mm
Anodised Perimeter: 428mm

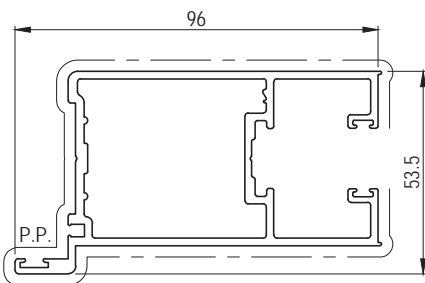

EP18500
SG WIDE COVER STILE
Paint Perimeter: 484mm
Anodised Perimeter: 522mm

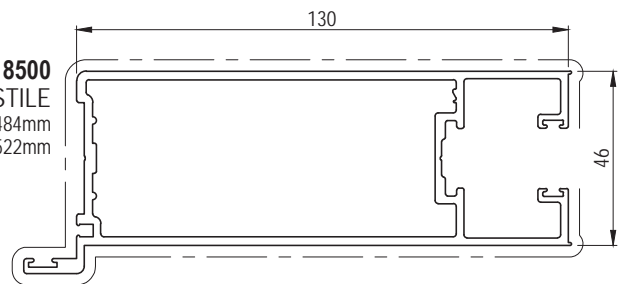

EP17134
SG COVER STILE
Paint Perimeter: 322mm
Anodised Perimeter: 483mm

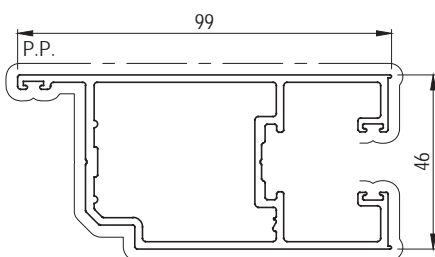

EP14649
SG MEETING STILE
Paint Perimeter: 306mm
Anodised Perimeter: 459mm

Please read in conjunction with Important Conditions – Index (also available on Capral website)

Extrusions

Scale 1:2

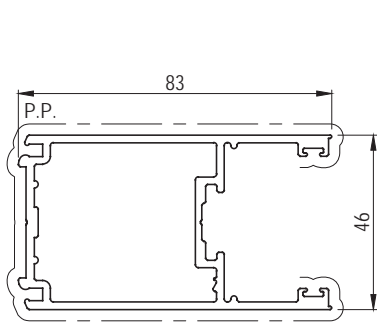

EP14987
 DG WIDE LOCK STILE
 Paint Perimeter: 342mm
 Anodised Perimeter: 480mm

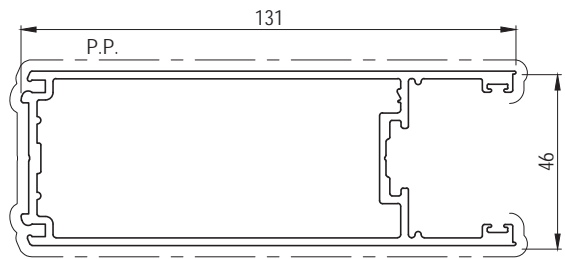

EP14893
 DG LOCK STILE
 Paint Perimeter: 256mm
 Anodised Perimeter: 384mm

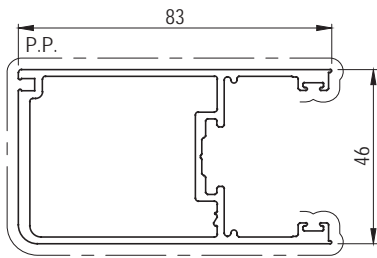

EP14983
 DG WIDE RADIUS STILE
 Paint Perimeter: 328mm
 Anodised Perimeter: 466mm

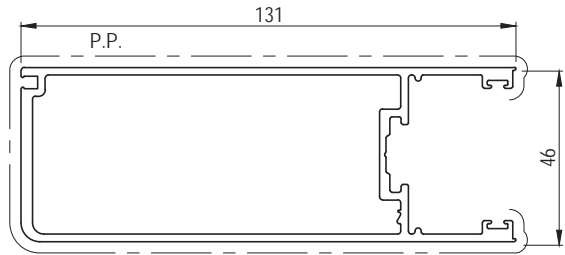

EP14894
 DG RADIUS STILE
 Paint Perimeter: 247mm
 Anodised Perimeter: 371mm

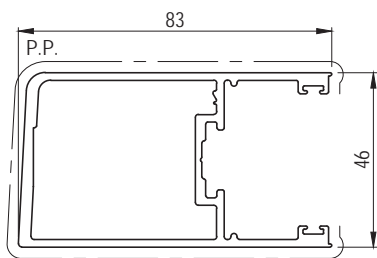

EP16978
 DG WIDE BEVEL STILE
 Paint Perimeter: 317mm
 Anodised Perimeter: 454mm

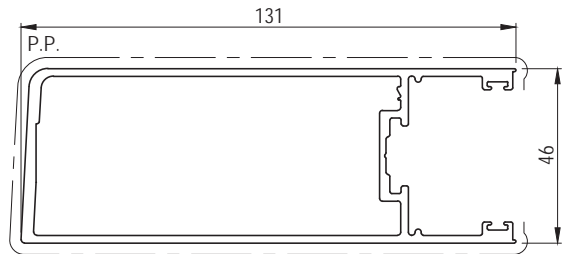

EP16979
 DG BEVEL STILE
 Paint Perimeter: 239mm
 Anodised Perimeter: 358mm

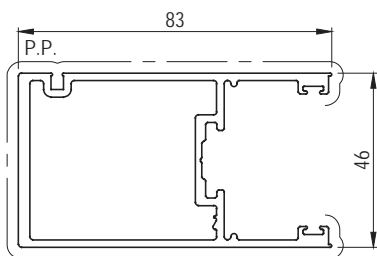

EP14985
 DG WIDE WIPER STILE
 Paint Perimeter: 330mm
 Anodised Perimeter: 468mm

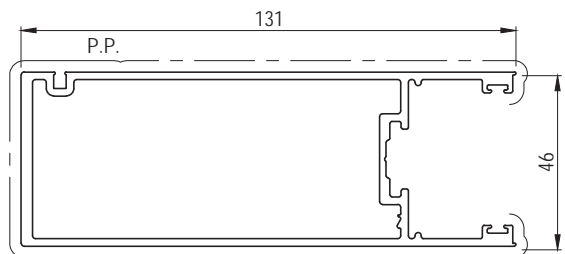

EP14961
 DG WIPER STILE
 Paint Perimeter: 248mm
 Anodised Perimeter: 372mm

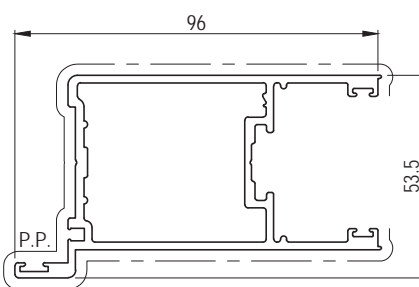

EP18501
 DG WIDE COVER STILE
 Paint Perimeter: 317mm
 Anodised Perimeter: 454mm

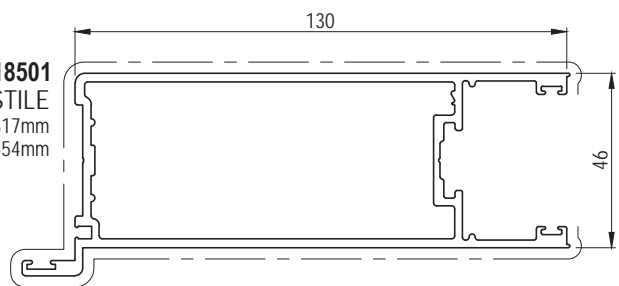

EP17135
 DG COVER STILE
 Paint Perimeter: 284mm
 Anodised Perimeter: 426mm

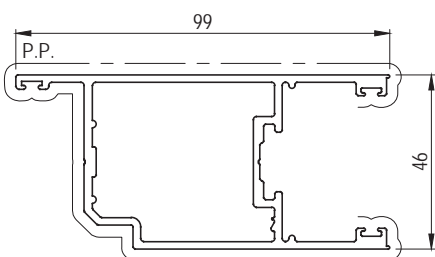

EP14895
 DG MEETING STILE
 Paint Perimeter: 306mm
 Anodised Perimeter: 403mm

Please read in conjunction with Important Conditions – Index (also available on Capral website)

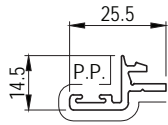

EP1546
MEETING STILE
ADAPTOR
Paint Perimeter: 100mm
Anodised Perimeter: 100mm

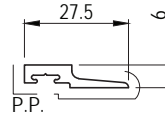

EL5387
INTERLOCK ADAPTOR
Paint Perimeter: 100mm
Anodised Perimeter: 100mm

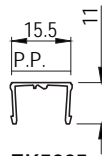

EK5925
400/601 FLUSH FILLER
Paint Perimeter: 100mm
Anodised Perimeter: 100mm

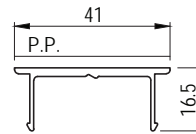

EP2211
425/625 FLUSH FILLER
Paint Perimeter: 100mm
Anodised Perimeter: 144mm

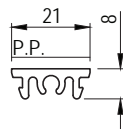

E19991
419 SG FLUSH FILLER
Paint Perimeter: 100mm
Anodised Perimeter: 100mm

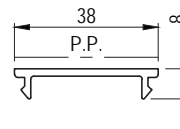

E34300
419 DG FLUSH FILLER
Paint Perimeter: 100mm
Anodised Perimeter: 103mm

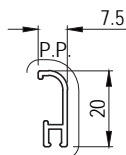

EPD0284
F/D WEATHER STRIP
Paint Perimeter: 100mm
Anodised Perimeter: 100mm

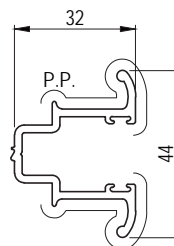

EP10457
FINGER PULL
Paint Perimeter: 105mm
Anodised Perimeter: 238mm

225 DOOR STOPS

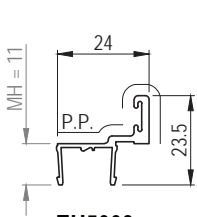

EU5003
300 DOOR STOP
Paint Perimeter: 100mm
Anodised Perimeter: 125mm

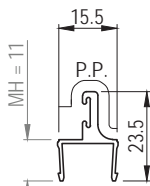

EL4053
400/601 DOOR STOP
Paint Perimeter: 100mm
Anodised Perimeter: 108mm

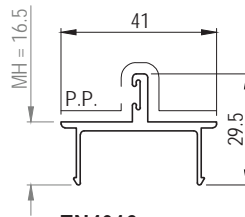

EN4016
425 DOOR STOP
Paint Perimeter: 100mm
Anodised Perimeter: 177mm

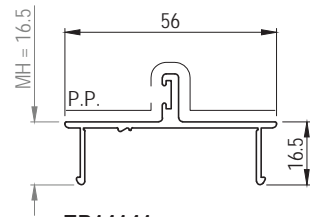

EP14141
450 DOOR STOP
Paint Perimeter: 141mm
Anodised Perimeter: 213mm

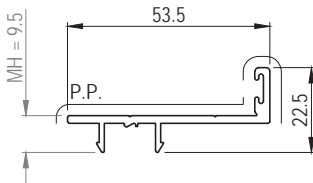

EP6047
419 DOOR STOP
Paint Perimeter: 100mm
Anodised Perimeter: 178mm

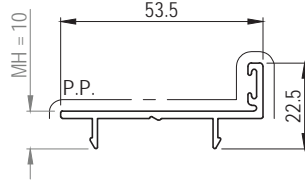

EP15181
419 DG DOOR STOP
Paint Perimeter: 120mm
Anodised Perimeter: 180mm

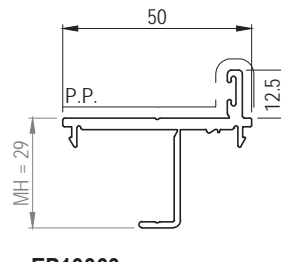

EP13363
419 50mm DOOR STOP
Paint Perimeter: 156mm
Anodised Perimeter: 234mm

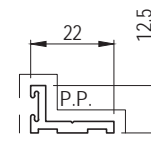

EL6478
PLANT ON DOOR STOP
Paint Perimeter: 100mm
Anodised Perimeter: 100mm

MITRE HEIGHT = MH

ALTERNATIVE DOOR STOPS

REFER TO DOOR REBATE TABLE Sec3, PAGE 2 FOR USE

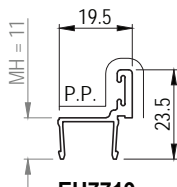

EU7719
SG NARROWLINE ALT. DOOR STOP
Paint Perimeter: 100mm
Anodised Perimeter: 115mm
7.5mm OFFSET FROM FRAME CTR

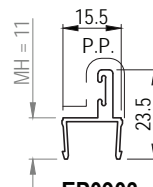

EP0903
SG NARROWLINE ALT. DOOR STOP
Paint Perimeter: 100mm
Anodised Perimeter: 110mm
1.5mm OFFSET FROM FRAME CTR

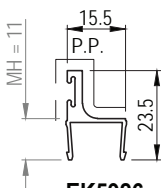

EK5926
SG NARROWLINE ALT. DOOR STOP
Paint Perimeter: 100mm
Anodised Perimeter: 107mm
- 7.5mm OFFSET FROM FRAME CTR

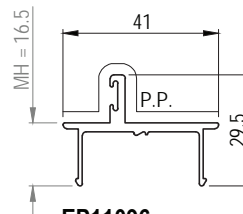

EP11096
DG NARROWLINE ALT. DOOR STOP
Paint Perimeter: 100mm
Anodised Perimeter: 179mm
- 8mm OFFSET FROM FRAME CTR

MITRE HEIGHT = MH

Please read in conjunction with Important Conditions – Index (also available on Capral website)

Extrusions

Scale 1:2

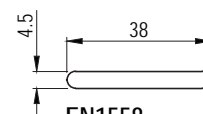
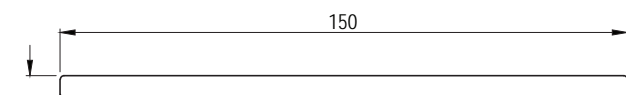
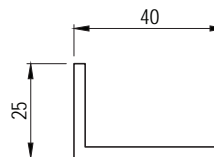
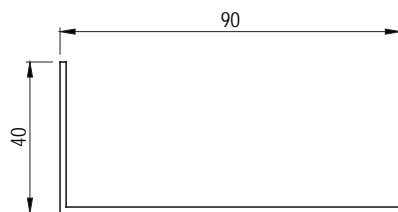
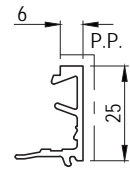
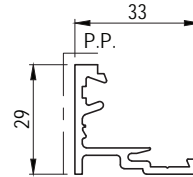
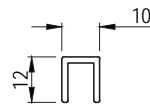
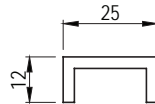
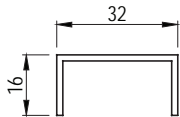
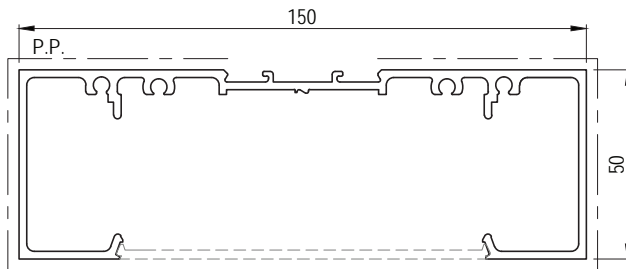
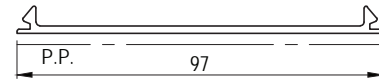
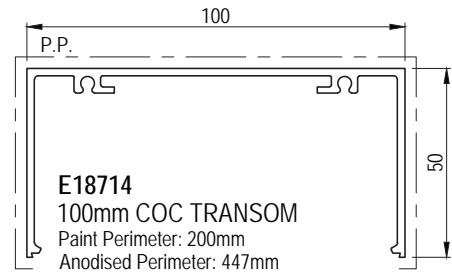
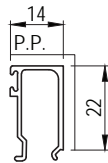
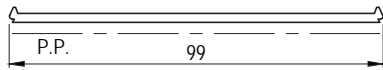
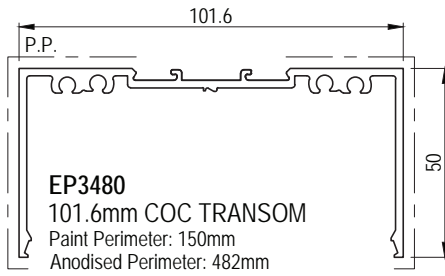

Please read in conjunction with Important Conditions – Index (also available on Capral website)

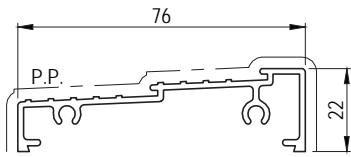

E35737
76mm x 22mm THRESHOLD
Paint Perimeter: 132mm
Anodised Perimeter: 315mm
* SEE NOTE

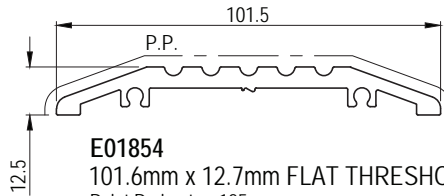

E01854
101.6mm x 12.7mm FLAT THRESHOLD
Paint Perimeter: 125mm
Anodised Perimeter: 234mm
* SEE NOTE

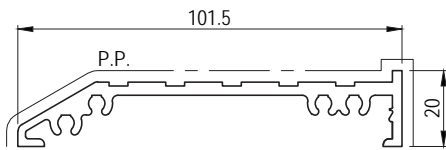

EP2365
101.6mm x 20mm FLAT THRESHOLD
Paint Perimeter: 143mm
Anodised Perimeter: 340mm

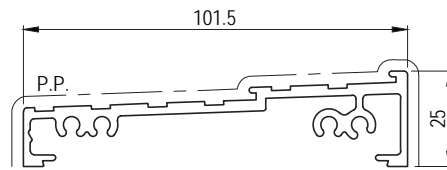

EP2212
101.6mm x 25mm THRESHOLD
Paint Perimeter: 173mm
Anodised Perimeter: 422mm
* SEE NOTE

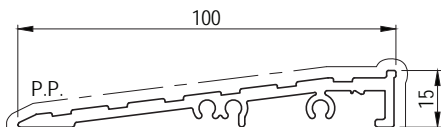

EP13539
100mm x 15mm RAMPED THRESHOLD
Paint Perimeter: 202mm
Anodised Perimeter: 302mm
* FOR OPEN IN SEE NOTE

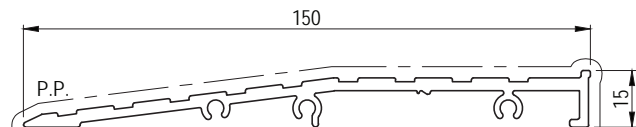

EP13540
150mm x 15mm RAMPED THRESHOLD
Paint Perimeter: 280mm
Anodised Perimeter: 420mm
* FOR OPEN IN SEE NOTE

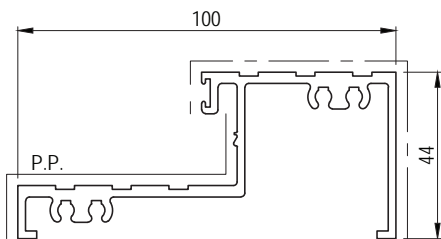

EP2366
100mm x 44mm OPEN OUT THRESHOLD
Paint Perimeter: 205mm
Anodised Perimeter: 507mm

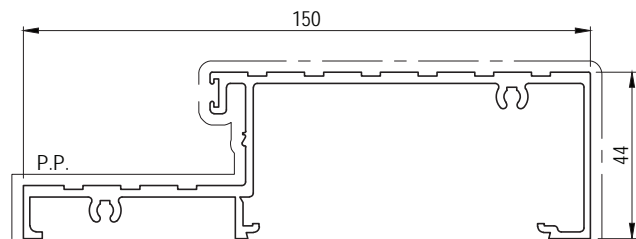

EP5796
150mm x 44mm OPEN OUT THRESHOLD
Paint Perimeter: 294mm
Anodised Perimeter: 633mm

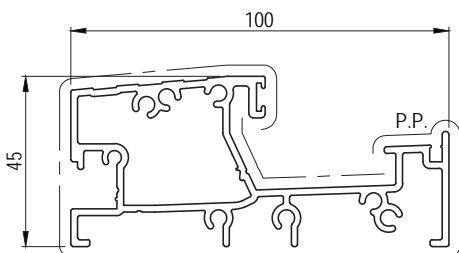

EP15939
100mm x 45mm OPEN IN THRESHOLD
Paint Perimeter: 384mm
Anodised Perimeter: 575mm

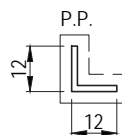

EK9102
12 x 12 x 1.6mm AL ANGLE
Paint Perimeter: 100mm
Anodised Perimeter: 100mm

*** IMPORTANT NOTE:** THIS DOOR WHEN FABRICATED WITH THIS THRESHOLD IS NOT WATER RATED AND DOES NOT CONFORM TO AUSTRALIAN STANDARD AS2047 AND IS INTENDED FOR INTERNAL APPLICATIONS ONLY OR WHERE THE BUILDER MAKES ALLOWANCES TO ADEQUATELY SHELTER THE PRODUCT.

Extrusions

Scale 1:2

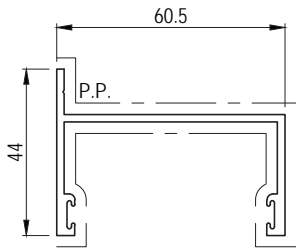

E53243
FIN SLIDER GUIDE
 Paint Perimeter: 220mm
 Anodised Perimeter: 294mm

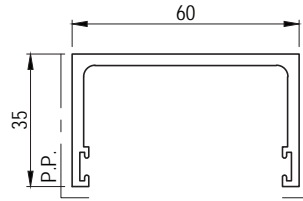

E18687
SLIDER GUIDE
 Paint Perimeter: 100mm
 Anodised Perimeter: 277mm

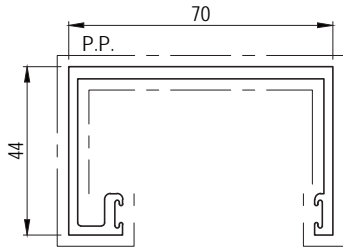

EK7621
1030 SLIDER GUIDE
 Paint Perimeter: 325mm
 Anodised Perimeter: 371mm

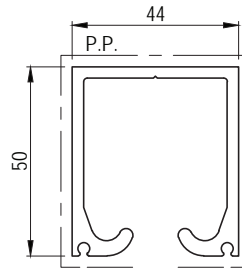

EN8012
1061 ROLLER HEAD
 Paint Perimeter: 130mm
 Anodised Perimeter: 342mm

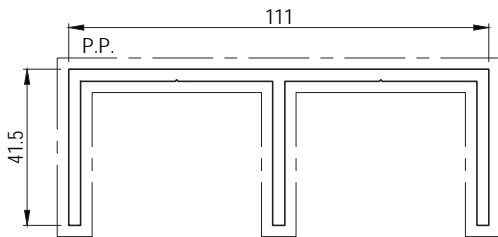

EK9075
1026/1027 DOUBLE SLIDER HEAD
 Paint Perimeter: 458mm
 Anodised Perimeter: 458mm

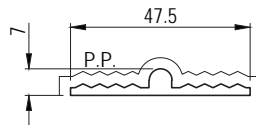

EP0892
1022 SLIDER TRACK
 Paint Perimeter: 100mm
 Anodised Perimeter: 109mm

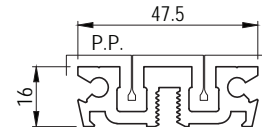

EK8593
1021 RECESSED SLIDER TRACK
 Paint Perimeter: 104mm
 Anodised Perimeter: 256mm

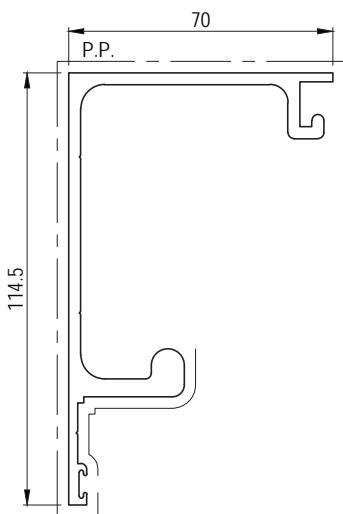

EK7817
1030 HEAD TRACK BASE
 Paint Perimeter: 253mm
 Anodised Perimeter: 484mm

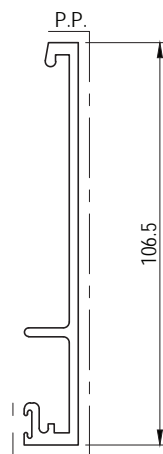

EK7818
1030 TRACK COVER
 Paint Perimeter: 127mm
 Anodised Perimeter: 306mm

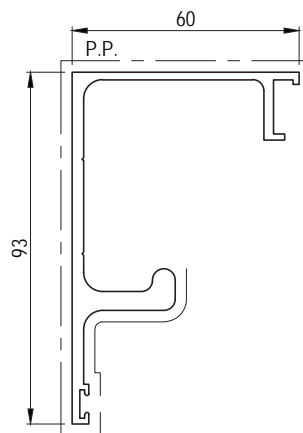

E18685
1031 HEAD TRACK BASE
 Paint Perimeter: 170mm
 Anodised Perimeter: 407mm

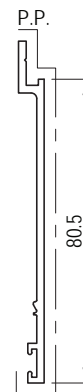

E18686
1031 TRACK COVER
 Paint Perimeter: 108mm
 Anodised Perimeter: 214mm

Please read in conjunction with Important Conditions – Index (also available on Capral website)

Extrusion Data

Extrusion	Description	Structural Properties *			
		Ixx (10 ³ mm ⁴)	Iyy (10 ³ mm ⁴)	Zxx (10 ³ mm ³)	Zyy (10 ³ mm ³)
E01854	101.6 x 12.7mm Flat Threshold	4.309	406.749	0.551	8.007
E14422	100mm Coc Filler	0.321	178.518	0.056	3.688
E18685	1031 Head Track Base	499.881	191.889	9.109	4.276
E18686	1031 Track Cover	153.453	0.648	3.382	0.131
E18687	Jamb Adaptor	45.099	211.367	1.289	7.046
E18714	100mm Coc Transom	106.602	690.998	2.849	13.820
E19991	419 SG Flush Filler	0.382	2.812	0.073	0.270
E20784	36 x 16 x 1.6mm Channel	2.359	15.025	0.207	0.939
E34300	419 DG Flush Filler	0.317	14.497	0.052	0.763
E35737	76mm x 22mm Threshold	7.478	176.308	0.589	4.237
E53243	Fin Jamb Adaptor	41.384	183.698	1.870	5.649
EAL23273	150 x 6mm Flat Bar	2.693	1682.700	0.897	22.435
EAL4035	50 x 6mm Flat Bar	0.900	62.500	0.300	2.500
EK5925	400/601 Flush Filler	0.452	1.356	0.062	0.166
EK5926	SG Narrowline Alt. Door Stop	2.824	1.901	0.229	0.176
EK5939	Coc Filler	0.121	193.824	0.045	3.921
EK7556	22mm Bead	5.135	2.142	0.351	0.279
EK7621	Slider Guide	127.043	359.245	4.462	9.725
EK7817	1030 Head Track Base	1187.456	392.502	16.956	7.792
EK7818	1030 Track Cover	451.960	5.201	7.592	0.477
EK8593	Recessed Slider Track	9.282	75.429	1.129	3.165
EK9075	Double Slider Head	120.579	1069.961	4.127	19.254
EK9122	40 x 25 x 3mm Angle	9.405	30.623	0.493	1.153
EK9147	10 x 12 x 1.6mm Channel	0.685	0.724	0.096	0.145
EK9156	25 x 12 x 3mm Channel	4.551	10.481	0.570	0.838
EL2096	63 x 46mm Blade	68.133	50.821	2.077	2.089
EL4053	400/601 Door Stop	2.769	1.405	0.225	0.163
EL5387	Interlock Adaptor	0.251	3.937	0.079	0.241
EL6478	Plant On Door Stop	0.983	3.548	0.111	0.260
EME30823	90 x 40 x 16mm Angle	24.807	181.347	0.747	3.115
EN1558	38 x 4.5mm Flat Bar	0.275	19.089	0.122	1.002
EN3597	Rail Louvre Adaptor	2.327	22.845	0.200	0.914
EN4016	425 Door Stop	5.363	19.292	0.344	0.931
EN4023	62 x 48mm Throated Blade	800.900	55.242	24.907	2.173
EN8012	Roller Head	180.759	161.741	7.182	7.352
EP0892	Slider Track	0.299	21.717	0.057	0.914
EP0903	SG Narrowline Alt. Door Stop	2.767	1.623	0.225	0.163
EP10457	Finger Pull	30.069	27.432	1.361	1.460
EP11096	DG Narrowline Alt. Door Stop	4.507	20.275	0.289	0.924
EP13363	419 50mm Sash Adaptor	21.531	47.806	0.878	1.652
EP13539	100mm x 15mm Ramped Threshold	4.907	341.231	0.581	6.036
EP13540	150mm x 15mm Ramped Threshold	7.441	1102.091	0.949	13.486
EP14141	450 Door Stop	6.225	44.394	0.402	1.581

Please read in conjunction with Important Conditions – Index (also available on Capral website)

Extrusion Data

Extrusion	Description	Structural Properties *			
		Ixx (10 ³ mm ⁴)	Iyy (10 ³ mm ⁴)	Zxx (10 ³ mm ³)	Zyy (10 ³ mm ³)
EP14647	SG Lock Stile	210.074	481.915	9.094	11.313
EP14648	SG Radius Stile	194.419	584.667	8.355	13.413
EP14649	SG Meeting Stile	211.963	528.242	8.540	9.554
EP14893	DG Lock Stile	212.121	425.496	9.179	9.451
EP14894	DG Radius Stile	199.191	426.330	8.556	9.323
EP14895	DG Meeting Stile	213.898	458.632	8.583	8.680
EP14925	Thick Glass Adaptor	12.526	17.202	0.758	0.615
EP14960	SG Wiper Stile	215.152	521.773	9.182	11.887
EP14961	DG Wiper Stile	217.194	451.315	9.261	9.733
EP14983	DG Wide Radius Stile	305.122	1527.989	13.156	22.596
EP14984	SG Wide Wiper Stile	277.445	1230.485	11.874	21.048
EP14985	DG Wide Wiper Stile	310.633	1575.688	13.296	22.949
EP14986	SG Wide Radius Stile	303.075	1380.303	13.068	20.900
EP14987	DG Wide Lock Stile	305.609	1486.565	13.234	22.154
EP14988	SG Wide Lock Stile	303.489	1636.280	13.142	24.590
EP15181	419 DG Door Stop	2.874	47.759	0.224	1.512
EP1546	Meeting Stile Adaptor	1.240	3.696	0.131	0.285
EP15939	100mm x 45mm Open In Threshold	126.234	691.019	5.493	12.516
EP16765	Midrail Coupler	13.464	41.304	0.686	2.094
EP16976	SG Wide Bevel Stile	301.037	1640.877	12.955	24.620
EP16977	SG Bevel Stile	207.644	488.407	8.917	11.459
EP16978	DG Wide Bevel Stile	303.113	1491.333	13.044	22.252
EP16979	SG Bevel Stile	209.689	421.881	9.008	9.362
EP17096	Louvre Adaptor	6.888	65.943	0.394	2.324
EP17134	SG Cover Stile	249.693	585.448	8.873	11.488
EP17135	DG Cover Stile	251.542	508.382	8.977	10.473
EP17152	SG 50mm Midrail	85.839	110.518	2.867	4.522
EP17153	TG 50mm Midrail	57.933	107.500	2.044	4.594
EP17154	DG 50mm Midrail	45.668	102.327	1.711	4.182
EP18269	SG Mid Rail	769.635	225.819	13.971	9.228
EP18270	DG Mid Rail	624.551	223.034	11.337	9.293
EP18286	DG Shallow Rail	306.068	178.226	6.848	7.556
EP18287	DG Rail	544.905	219.395	9.296	9.373
EP18288	SG Rail	605.735	221.079	10.050	9.330
EP18289	SG Shallow Rail	351.338	179.823	7.993	7.519
EP18353	DG Extended Rail	1118.916	278.178	14.331	11.992
EP18354	SG Extended Rail	1208.943	279.964	15.153	11.936
EP18500	SG Wide Cover Stile	369.318	1938.758	12.830	25.549
EP188501	DG Wide Cover Stile	371.335	1767.519	12.928	24.116
EP2211	425/625 Flush Filler	2.265	19.082	0.169	0.927
EP2212	101.6mm Threshold	14.983	603.487	1.072	10.802
EP2232	33mm 419 Frameless Glazing Adaptor	15.886	17.783	0.877	0.764
EP2233	33mm 419 Glazing Channel	25.179	42.851	1.647	2.580

Please read in conjunction with Important Conditions – Index (also available on Capral website)

Extrusion Data

Extrusion	Description	Structural Properties *			
		Ixx (10 ³ mm ⁴)	Iyy (10 ³ mm ⁴)	Zxx (10 ³ mm ³)	Zyy (10 ³ mm ³)
EP2365	101.6mm Flat Threshold	9.058	531.175	0.742	9.730
EP2366	100mm x 44mm Open Out Threshold	133.519	644.442	5.570	11.541
EP3480	101.6mm Coc Transom	106.271	764.660	2.794	15.052
EP3482	150mm Coc Transom	260.785	2322.211	7.612	30.963
EP5796	150mm x 44mm Open Out Threshold	179.117	1635.409	6.876	20.807
EP6047	419 Door Stop	2.816	48.691	0.220	1.582
EPD0121	Aluminium Slat 92 x 12mm	264.267	7.596	5.503	1.266
EPD0217	Aluminium Slat 100 x 19mm	331.626	8.229	6.370	1.372
EPD0223	SG & TG Bead	7.499	1.691	0.426	0.187
EPD0224	DG Bead	4.234	0.141	0.299	0.041
EPD0284	Weather Strip	1.995	0.255	0.183	0.051
EU5003	300 Door Stop	2.832	5.609	0.233	0.361
EU7719	SG Narrowline Alt. Door Stop	2.786	3.184	0.228	0.243

* NOTE: The structural properties listed above are using the orientations as listed within the extrusion pages.

Components

Not To Scale

306910 - BLUE
GLAZING WEDGE
3mm GAP
250m ROLL - SC
(SPD00550)



306911 - RED
GLAZING WEDGE
3.5mm GAP
200m ROLL - SC
(SPD00550)



306912 - ORANGE
GLAZING WEDGE 4mm
GAP
200m ROLL - SC
(SPD00550)



306913 - YELLOW
GLAZING WEDGE
4.5mm GAP
200m ROLL - SC
(SPD00550)



306914 - WHITE
GLAZING WEDGE
5mm GAP
200m ROLL - SC
(SPD00550)



306915 - GREEN
GLAZING WEDGE
5.5mm GAP
150m ROLL - SC
(SPD00550)



306916 - GREY
GLAZING WEDGE
6mm GAP
150m ROLL - SC
(SPD00550)



306909 - BLACK
GLAZING WEDGE
7mm GAP
120m ROLL - SC
(SPD00550)



300004
GLAZING WEDGE
8mm GAP
100m ROLL - PVC
(M027104)



300005
GLAZING WEDGE
9.5mm GAP
100m ROLL



306908
1.2mm BACKING GASKET
300m ROLL - PVC
(SPD00543)



306905
4mm BACKING GASKET
300m ROLL - PVC
(SPD00561)



317200
8mm GLASS SETTING BLOCK
(8 x 24 x 120mm)
EACH - SANTOPRENE
(SPD04094)

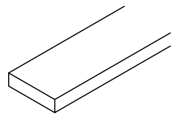

ALSO 50mm MIDRAIL

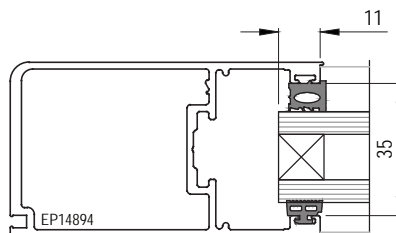
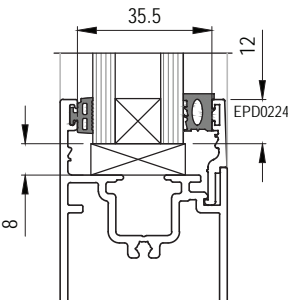
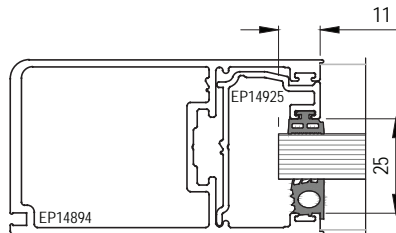
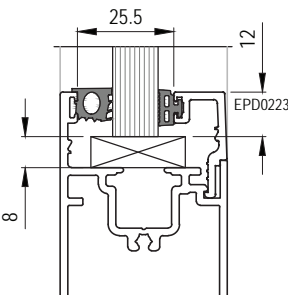
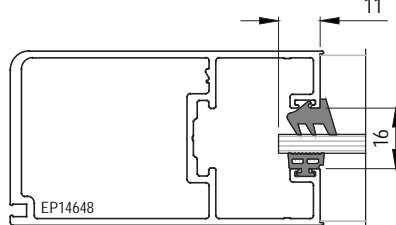
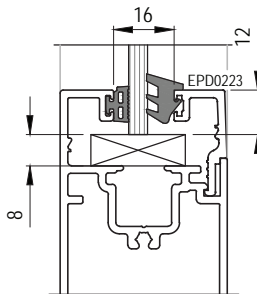

SG PANEL				
GLASS SIZE	GASKET	GAP	WEDGE	GAP
4mm	306905	4mm	300004	8mm
5mm	306905	4mm	306909	7mm
6mm	306905	4mm	306916	6mm
8mm	306905	4mm	306912	4mm
10mm	306908	1.2mm	306914	5mm
12mm	306908	1.2mm	306710	3mm

Use with 317195 Support Block

TG PANEL				
GLASS SIZE	GASKET	GAP	WEDGE	GAP
14mm	306905	4mm	306909	7mm
15mm	306905	4mm	306916	6mm
16mm	306905	4mm	306914	5mm
17mm	306905	4mm	306912	4mm
18mm	306905	4mm	306910	3mm

Use with 317195 Support Block

DG PANEL				
GLASS SIZE	GASKET	GAP	WEDGE	GAP
19mm	300004 W	8mm	300004	8mm
20mm	306909 W	7mm	300004	8mm
21mm	306909 W	7mm	306909	7mm
22mm	306905	4mm	300005	9.5mm
23mm	306905	4mm	300004	8mm
24mm	306905	4mm	306909	7mm
25mm	306905	4mm	306916	6mm
26mm	306905	4mm	306914	5mm
28mm	306905	4mm	306910	3mm
30mm	306908	1.2mm	306912	4mm
31mm	306908	1.2mm	306910	3mm

Use with 317195 Support Block

NOTE: POLYETHYLENE OR POLYPROPYLENE GLASS SETTING BLOCK RECOMMENDED FOR DG GLASS.
AVOID USING PVC DUE TO THE RISK OF PLASTICISER MIGRATION.

Please read in conjunction with Important Conditions – Index (also available on Capral website)

Components - Door Stops & Rebate Table

Not To Scale

300021
DOOR STOP 3mm
100m ROLL - SC
(M027214)



300022
DOOR STOP 5mm
100m ROLL - SC
(M027215)



300032
ALT. DOOR STOP
5mm
100m ROLL - PVC
(M027247)



302444
ACOUSTIC SEAL
5mm
305m ROLL
(M027456)



300023
DOOR STOP 7mm
100m ROLL - SC
(M027216)

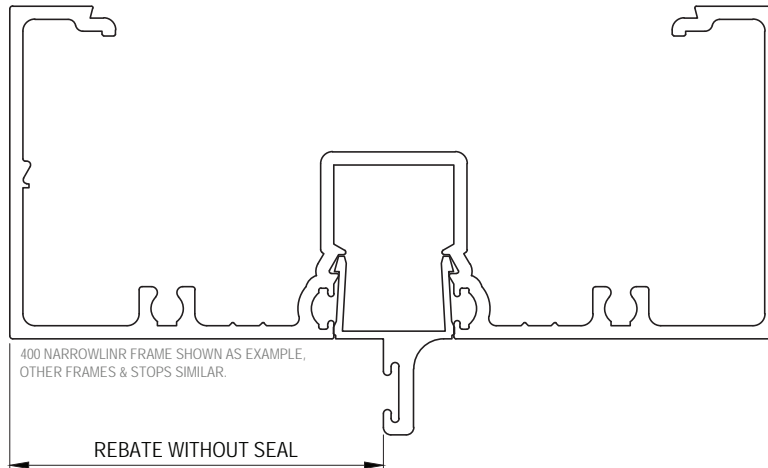

DOOR REBATE TABLE					
FRAMING SYSTEM	DOOR STOP EXTRUSION	REBATE WITHOUT SEAL	REBATE WITH 3mm DOOR STOP (300021)	REBATE WITH 5mm DOOR STOP (300022)	REBATE WITH 7mm DOOR STOP (300023)
300 Narrowline	EU5003	51mm	48mm	46mm	44mm
	EU7719	46mm	43mm	41mm	39mm
	EP0903	40mm	37mm	35mm	33mm
	EL4053	37mm	34mm	32mm	30mm
400 Narrowline	EL4053	49mm	46mm	44mm	42mm
	EP0903	52mm	49mm	47mm	45mm
	EK5926	43mm	40mm	38mm	36mm
425 Narrowline	EN4016	49mm	46mm	44mm	42mm
	EP11096	43mm	40mm	38mm	36mm
450 Narrowline	EP14141	49mm	46mm	44mm	42mm
601 Narrowline	EL4053	49mm	46mm	44mm	42mm
	EP0903	52mm	49mm	47mm	45mm
	EK5926	43mm	40mm	38mm	36mm
601 Narrowline (Externally glazed frame Open In Door)	EL4053	98mm	95mm	93mm	91mm
	EP0903	101mm	98mm	96mm	94mm
	EK5926	92mm	89mm	87mm	85mm
600 Narrowline	Plant On	NA	Position as required		
625 Narrowline	Plant On	NA	Position as required		
	EN4016	73mm	70mm	68mm	66mm
	EP11096	67mm	64mm	62mm	60mm
419 SG Flushline	EP6047	50mm	47mm	45mm	43mm
419 DG Flushline	EP15181				

Please read in conjunction with Important Conditions – Index (also available on Capral website)

Components

Not To Scale

308233
WEATHER STRIP CLIP
4m LENGTH - PRE PUNCHED
(SPD02012)



322122
WOOL PILE 6mm
300m ROLL - BLACK
(SPD05060)



317191 - 8mm
300045 - 13mm
301410 - 28mm
POLYPILE
600m/500m/500m/250m ROLLS
(PS08/11/13/16/28)



310801
7.5mm FIN SEAL
300m ROLL
(WP041)



300027
SILL FLAP
250m
(M027231)



309644
LOUVRE SEAL
600m ROLL
(PV032)



316051
CO-EXT EXPANSION JOINT SEAL
500m ROLL - SC
(10148)



314416
CO-EXTRUDED FIN SEAL
300m ROLL
(SPD02645)



302246
FILLER TAPE
100m ROLL - BLACK
(MPF108BLACK)



302444
ACOUSTIC DOOR STOP 5mm
305m ROLL - SC
(M027456)



323403
GUTTER SEAL
EACH - 3m LENGTH
(SPD05067)



301296
PRESSURE FIN SEAL
400m ROLL - BLACK
(M027239)

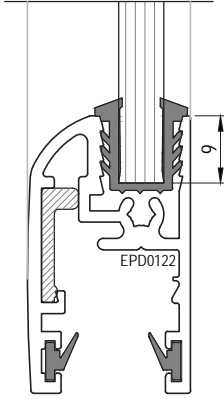

300031
6mm GLAZING CHANNEL
100m ROLL - PVC
(M027246)

SLAT PANEL GLAZING FRAME

309639
9mm X 1.6mm SINGLE SIDED TAPE
46m ROLL
(PT0080046)



Components

Not To Scale

300058

10g x 12mm CSK UC SCREW
EACH
(M028354)

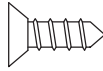

HINGE

300672

8g x 25mm PAN SCREW
EACH
(M029642)

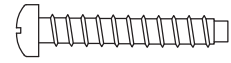

FRAME

309156

8g x 13mm CSK UC SCREW
EACH
(FSC151)

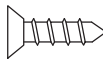

STRIKER PLATE, STILE END CAP

309155

8g x 45mm PAN SCREW
EACH
(FSC151)

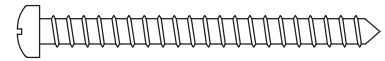

MIDRAIL COUPLER, 50mm MIDRAIL (OPTIONAL), LOUVRE ADAPTOR

310992

8g x 38mm CSK SCREW
200 PACK
(FSC453)

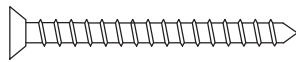

EURO BRACKET (ADDITIONAL)

310186

8g x 15mm PAN SCREW
EACH
(M028259)

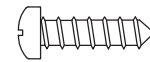

215 OPEN IN SILL ADAPTOR

300059

10g x 25mm SS PAN SCREW
EACH
(M028598)

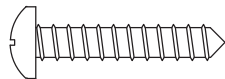

LOUVRE BLADES

310321

8g x 13mm PAN SCREW
EACH
(FSC103)

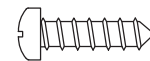

50mm MIDRAIL BRACKET

309975

6g x 32mm CSK SCREW
EACH
(ST0004)

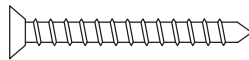

SLAT PANEL GLAZING FRAME

300061

8g x 10mm PAN SCREW
EACH
(M028752)

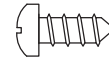

SUPPORT BLOCK, MEETING STILE ADAPTOR

300248

GUIDE BUTTON
EACH
(M580170)



309139 - BLACK

309140 - BRONZE

309145 - PLAIN

309147 - WHITE

RIVET

Ø3.2 x 4.8mm Aluminium
(FRV001)

FLUSH BOLT GUIDE

309327

HOLE PLUG
EACH - BLACK
(H036)



308231 - RH

308232 - LH

WEATHER STRIP CAP

EACH - BLACK
(SPD02013)

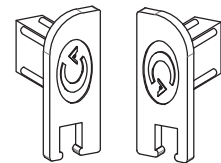

314625

BUMPER STOP
EACH
(HM399)

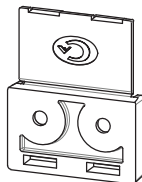

306961

RUBBER GROMMET
EACH
(SPD00800)

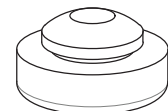

316062

BUMPER STOP ADAPTOR
EACH
(SPD03580)

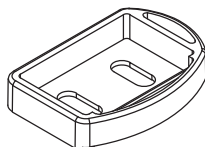

311558

BUMPER STOP
EACH - BLACK
(PV122)

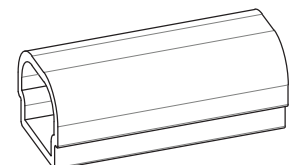

USE WITH 314625

Please read in conjunction with Important Conditions – Index (also available on Capral website)

Components

Not To Scale

315483
EURO RAIL FIXING BRACKET
PACK 4 - ALUMINIUM
(SPD03068)

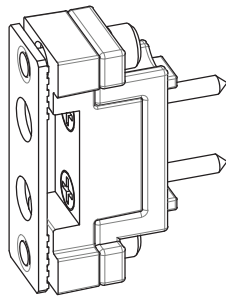

322182
DG SPIGOT KIT
4 SETS - 40mm BOLT
(SPD04829)

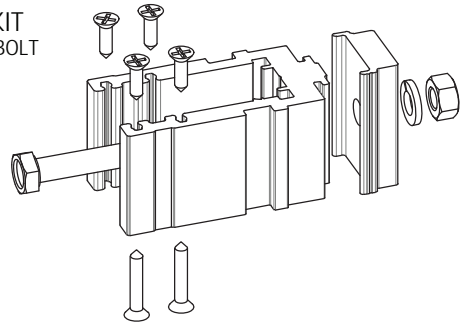

315486
JACKING SCREW
EACH - S/STEEL
(SPD03229)

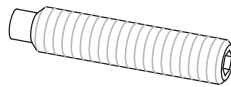

322183
SG SPIGOT KIT
4 SETS - 50mm BOLT
(SPD04828)

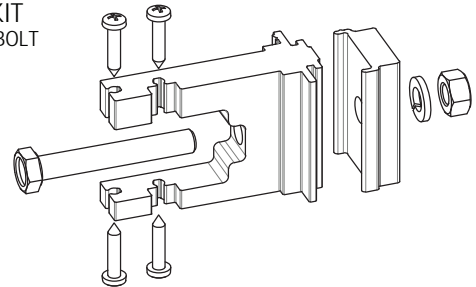

315487
SG JACKING SCREW FOOT
EACH - BLACK
(SPD03217)



315488
DG JACKING SCREW FOOT
EACH - BLACK
(SPD03218)



NON STOCKED
M8 S/S ALL THREAD TIE ROD
EACH

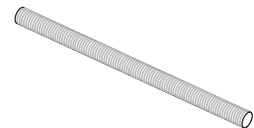

USE WITH 322182 OR 322183

315482
PRESSED NUT
EACH - STAINLESS STEEL
(SPD03187)

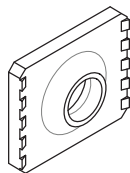

322233
GLASS SUPPORT BLOCK
EACH - BLACK
(SPD04952)

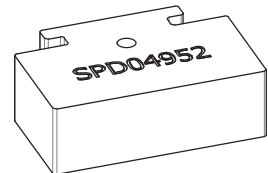

320313
50mm MIDRAIL BRACKET
10 PACK
(SPD04464)

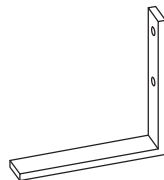

317195
GLASS SETTING BLOCK
(20 x 25 x 70mm)
50 PACK - SANTOPRENE
(SPD04087)

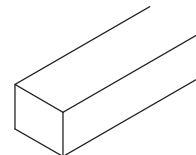

306653
CORNER CLEAT
EACH
(MEUR0002)

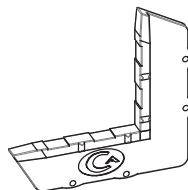

MC 90763
225 DG DRILL JIG



USE WITH EP18286, EP18287, EP18353 & EP18270 FOR DG SPIGOT

Components

Not To Scale

HINGED DOOR

316121
7714 ARM DOOR CLOSER
SATIN S/STEEL, MAX 80kg/1100mm WIDTH
EACH
(7714HSSS / SPD03716)

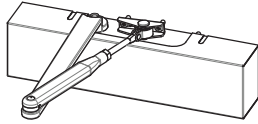

316122
7714 SLIDE TRACK DOOR CLOSER
SATIN S/STEEL, MAX 80kg/1100mm WIDTH
EACH
(7714SRSSS / SPD03716)

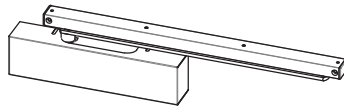

317647
2615 DOOR CLOSER
SATIN S/STEEL, MAX 160kg/1600mm WIDTH
EACH
(M2615DASIL)

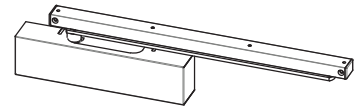

316123
7726 ARM DOOR CLOSER
SATIN S/STEEL, MAX 120kg/1400mm WIDTH
EACH
(7726HSSS / SPD03716)

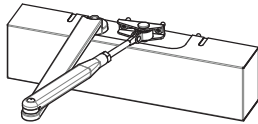

316124
7726 SLIDE TRACK DOOR CLOSER
SATIN S/STEEL, MAX 120kg/1400mm WIDTH
EACH
(7726SRSSS / SPD03716)

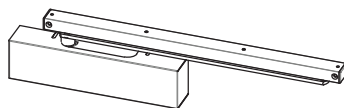

317648
2615 OPENING DAMPENER
SATIN S/STEEL, MAX 80kg/1100mm WIDTH
EACH
(M2616-153)

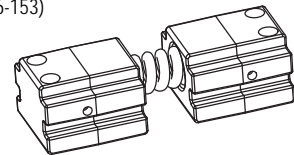

300378
ALUMINIUM HINGE
EACH
(M981717/SPD03741)

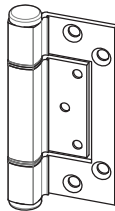

40kg MAX LOAD WITH 3 HINGES

311259
S/STEEL PARLIAMENT HINGE
EACH
(HF011/SPD04009)

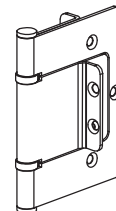

MAX PANEL WEIGHT:
3 HINGES = 60KG 4 HINGES = 80KG
RADIUS STILES ONLY

310526
S/STEEL FAST
FIX HINGE (ASSA ABLOY)
EACH
(SPD04008/HF009)

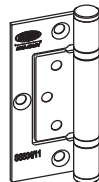

MAX PANEL WEIGHT:
3 HINGES = 60kg 4 HINGES = 80kg

317662
ALUMINIUM FAST FIX HINGE
EACH
(MA104SNAALUM)



100kg MAX LOAD WITH 3 - 6 HINGES.
REF. TO McCALLUM SPECIFICATIONS FOR FURTHER DETAILS
RADIUS STILES ONLY

317231
ADJUSTABLE HINGE
EACH - P/COAT SILVER
PURCHASE TO ORDER - NON STOCKED
(SPD04005)

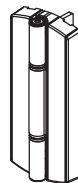

MAX PANEL WEIGHT:
3 HINGES = 100KG
RADIUS STILES ONLY

317649
ALUMINIUM FAST FIX IN LINE HINGE
EACH
(MA105SNA)

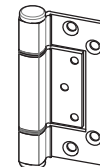

80kg MAX LOAD WITH 3 - 6 HINGES.
REF. TO McCALLUM SPECIFICATIONS FOR FURTHER DETAILS

320167
ALT. S/STEEL FAST
FIX HINGE (CUSTOM)
EACH
(SPD04371)

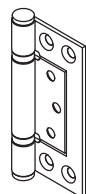

MAX PANEL WEIGHT:
3 HINGES = 60kg 4 HINGES = 80kg

300380
RECESSED FLUSH BOLT
35mm PANEL
EACH
(M981904BK)

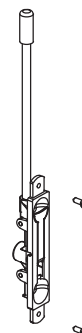

317196
STILE END CAP
20 PACK - BLACK
(SPD03857)

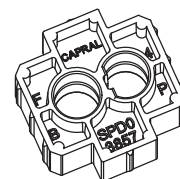

USE WITH 4P OPTIMUM
& FLUSH BOLT

301744
FLUSH BOLT GUIDE
EACH - BLACK
(H366/M586120)

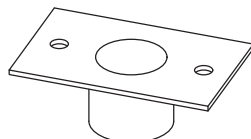

Please read in conjunction with Important Conditions – Index (also available on Capral website)

Components

Not To Scale

SLIDING DOOR

300375
1021 FLOOR ROLLER
PAIR
(M981466)

SUITS TRACK EK8593
MAX PANEL 160kg

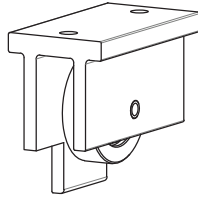

300480
1031 HEAD ROLLER
1 PACK
(MSC1066)

SUITS E18685/E18686
MAX PANEL 80kg

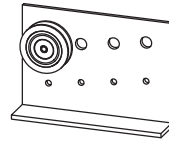

300376
1022 FLOOR ROLLER
EACH
(M981457)

SUITS TRACK EP0892
MAX PANEL 300kg

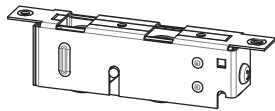

300371
1061 HEAD ROLLER
EACH
(M981010)

SUITS EN8012
MAX PANEL 160kg

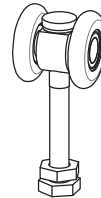

300381
1030 HEAD ROLLER
2 PACK
(M981951)

SUITS TRACK
EK7817/EK7818
MAX PANEL 272kg

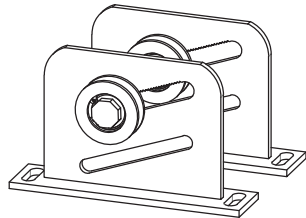

300372
1061 ROLLER BRACKET
EACH
(M981013)

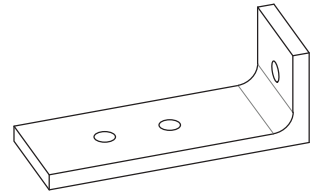

300664
1030 PELMET BRACKET
EACH
(M981952)

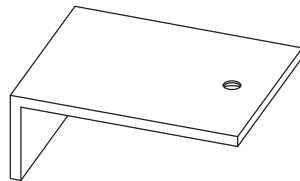

PIVOT DOOR

316125 - NON H/O (9835N) **316126** - 90° H/O (9835H90) **316127** - 105° H/O (9835H105)
9800 CONCEALED OVERHEAD CLOSER
SIZE 3, MAX 115kg / 1050mm PANEL WIDTH
EACH
(SPD03713)

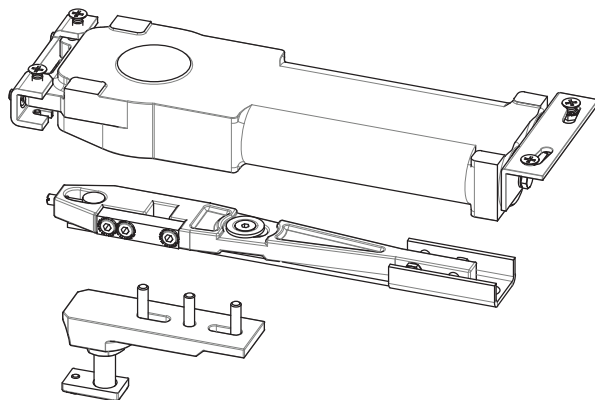

Components

Not To Scale

OPTIMUM - HINGED LOCK

315501
2-POINT LOCK KIT 24mm
BOLT 30BS
EACH
(SPD03256)



REFER TO 'SINGLE POINT LOCK'
SPAN TABLES IN SECTION 2 FOR
USE

315502
4-POINT LOCK KIT 24mm
BOLT 30mm BS
EACH
(SPD03257)



316483
4-POINT LOCK KIT 24mm
BOLT 40mm BS
EACH
(MOP40/4SBS/SSAS)



308305
TWIN BOLT LOCK RODS
& PLASTIC TIP KIT
(1.3m + 1.0m RODS)
5 PACK
(SPD02144/HL430)



REPLACE PLASTIC TIPS WITH
317201

317198 - RH **317197 - LH**
MEETING STRIKE
EACH
(SPD04072 / 73)

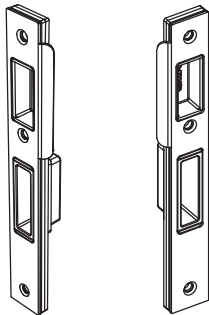

307747 - RH **307633 - LH**
STRIKE
EACH
(SPD01472)

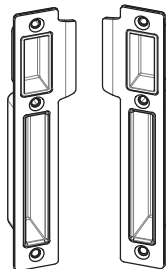

305729
4 POINT BOLT EXTENSION
KIT (1m ROD)
EACH
(FOR DOORS 2.4-2.5m HIGH)
(SPD03261)

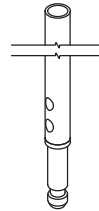

317201
HIGH PERFORMANCE SS
ROD TIP - 65mm
10 PACK - S/STEEL
(SPD04093)

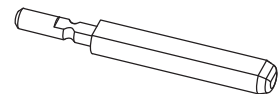

OPTIMUM - PIVOT LOCK

319592
OPTIMUM ROLLER
BOLT 40mm BS
EACH - ONLY
(OP40/1RBS/SS)

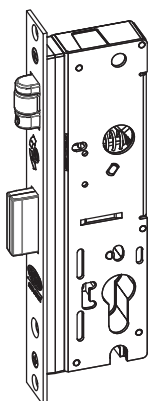

317198 - RH
317197 - LH
MEETING STRIKE
EACH
(SPD04072 / 73)

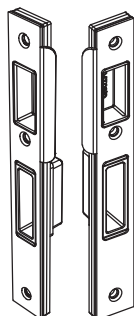

307747 - RH
307633 - LH
STRIKE
EACH
(SPD01472)

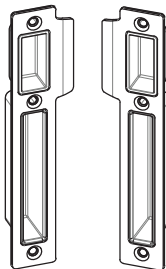

319582
OPTIMUM SLIDING
LOCK 30mm BS
EACH
(OP30/1SDN/SS)

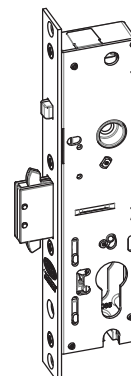

319593
OPTIMUM SLIDING
STRIKE
EACH
(P33600)

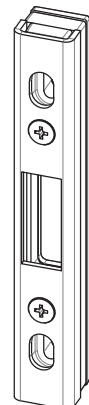

Please read in conjunction with Important Conditions – Index (also available on Capral website)

OTHER HANDLES & ACCESSORIES

316413
 PUSH PULL ENTRANCE SET
 EACH
 (M231X300SS)

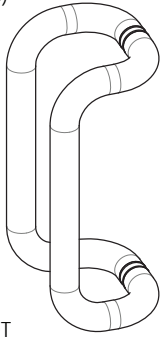

HINGED / PIVOT
 OPTIMUM & 3541 LOCKS

317693
 CAPRIO 800mm PULL
 HANDLE
 EACH
 (MCA16000SS)

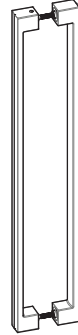

HINGED / PIVOT / SLIDING
 OPTIMUM & 3541 LOCKS

317691
 CAPRIO FLUSH PULL
 HANDLE
 EACH
 (MCA15002SS)

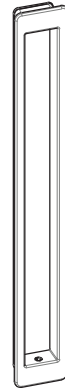

SLIDING
 OPTIMUM & 3541 LOCKS

316116 - KEYED TO DIFFER
 LOCK CYLINDER 76mm
 5 PACK
 (P33235)

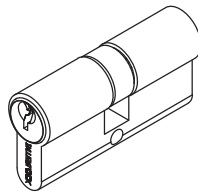

OPTIMUM LOCKS

315671 - KEY #J31

PURCHASE TO ORDER
 315672 - KEY #J32
 315673 - KEY #J33
 315674 - KEY #J34
 315675 - KEY #J35

317692
 CAPRIO
 ESCUTCHEON
 EACH
 (MCA15004SS)

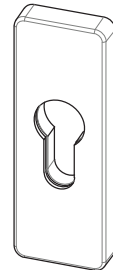

OPTIMUM LOCKS

322124 - KEY SPECIAL (#J031 - #J040)
 LOCK CYLINDER 76mm
 INTERNAL TURN SNIB
 EACH - OPTIMUM
 (P33234)

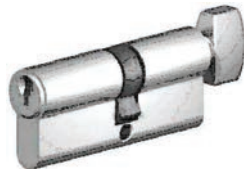

317646
 LC8810 POWER
 TRANSFER DEVICE
 EACH
 (MLC8810)

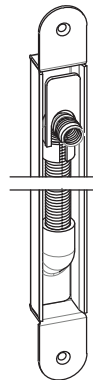

HINGED STILE
 SELECTOR & 3570 LOCKS

317643
 ES2100 ELECTRIC STRIKE
 EACH
 (MES2100)

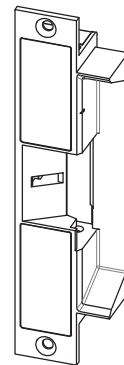

HINGED JAMB
 SELECTOR & 3570 LOCKS

G PULL HINGED / PIVOT HANDLE
 USE WITH 3541 LOCKS

301286 - MILL
301285 - CLEAR ANOD.
 'G' HANDLE PULL
 EACH
 (M981252)

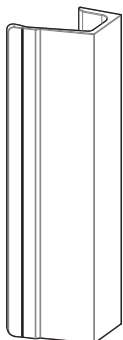

301305
 'G' HANDLE BOLT
 EACH - SS
 (M029641)

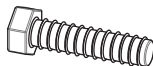

301311
 'G' HANDLE SPACER
 EACH - 43mm ZINC
 (M028560 or M029637)



Please read in conjunction with Important Conditions – Index (also available on Capral website)

Components

Not To Scale

3541 MORTICE - HINGED* / PIVOT* / SLIDING LOCK

311516 - CYLINDER
323244 - NO CYLINDER
 3541 LEVER HANDLE
 EACH
 (HL406)

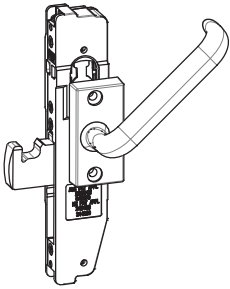

314469
 3541 TURN KNOB
 EACH
 (SPD02887)

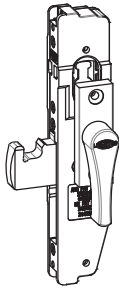

314468
 3541 DOUBLE
 CYLINDER
 EACH
 (SPD02886)



314636
 3541 MORTICE
 STRIKE
 EACH
 (SPD02897)



300365
 3541 STRIKE
 ADAPTOR
 EACH
 (M889033MF)



SLIDING ONLY

SELECTOR - HINGED LOCK SET *

315947 - CYL & KNOB
315948 - SINGLE CYL
315946 - DOUBLE CYL
 23mm BACK SET LOCK KIT
 INCLUDES HANDLE, CYLINDER & STRIKE
 EACH
 (3782-KIT04/05/01)

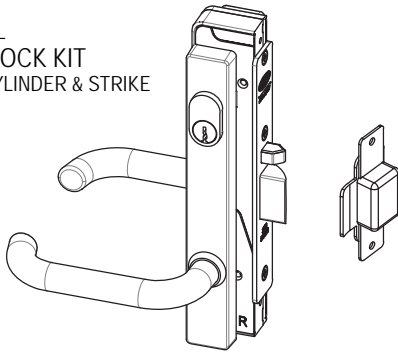

NOT COMPATIBLE WITH MEETING STILES

319492 - CYL & KNOB
319491 - SINGLE CYL
319480 - DOUBLE CYL
 30mm BACK SET LOCK KIT
 INCLUDES HANDLE, CYLINDER & STRIKE
 EACH
 (M5782-KIT04/05/01)

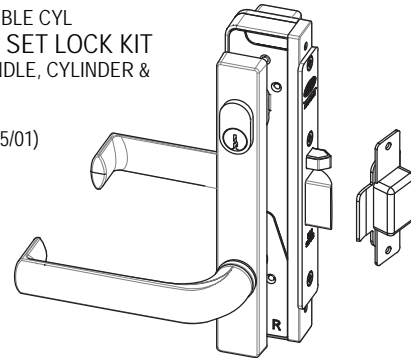

WIDE STILES ONLY

LEVER COMPRESSION LOCK - HINGED LOCK

313761
 LCL LOCK SET
 EACH - SINGLE PANEL ONLY
 (SPD03268)



307632 - LH **307746** - RH
 LCL STRIKE SET
 EACH
 (SPD01471)

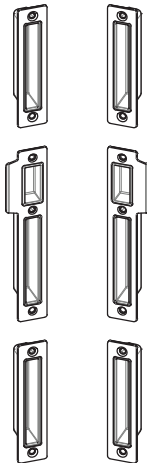

OPTIMUM MORTICE - SLIDING LOCK

316491
 OPTIMUM MORTICE LOCK &
 ARIA HANDLE KIT
 EACH
 (SPD03927)

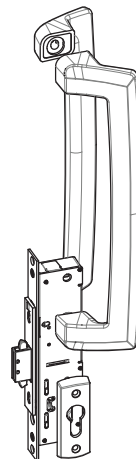

317041
 LOCK BODY
 PACKER
 10 PACK
 (SPD03894)



317042
 STRIKE PACKER
 10 PACK
 (SPD03895)



317043
 RECEIVER
 COVER
 10 PACK
 (SPD03928)



* REFER TO 'SINGLE POINT LOCK' SPAN TABLES IN SECTION 2 FOR USAGE

Please read in conjunction with Important Conditions – Index (also available on Capral website)

Components

Not To Scale

HINGED / PIVOT HANDLES
USE WITH OPTIMUM HINGED, PIVOT & LCL

317700 - BLACK
317701 - SILVER
317702 - SATIN NICKEL
317703 - STAINLESS STEEL
CAPRIO HANDLE SET
EACH
(M288-85)

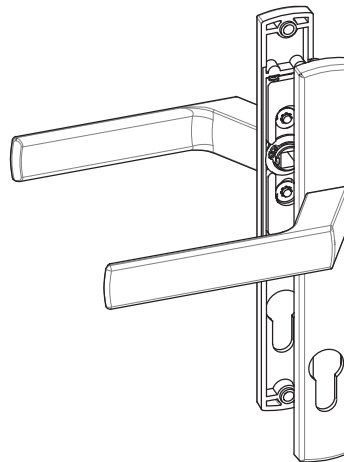

315524 - BLACK
315525 - SATIN CHROME
PALLADIUM HANDLE KIT
GIDGEE #37
DOUBLE CYLINDER
EACH
(SPD03260)

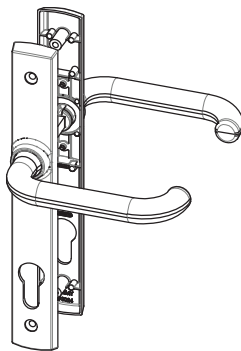

PURCHASE TO ORDER
315527 - WHITE
315526 - SILVER

313704 - BLACK
315510 - SATIN CHROME
313706 - SILVER
PALLADIUM HANDLE KIT
ARIA #27
DOUBLE CYLINDER
EACH
(SPD02622)

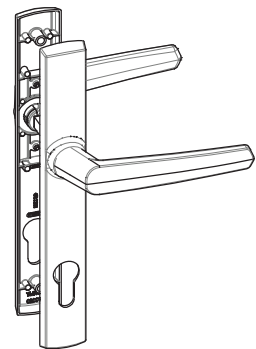

PURCHASE TO ORDER
315511 - WHITE

PALLADIUM HANDLE KIT
XTRA ARIA #27
DOUBLE CYLINDER, 85mm PITCH
EACH
(INCLUDE SNIB & LOCK ALERT
NOT COMPATIBLE WITH 4P LCL)
(SPD03259)

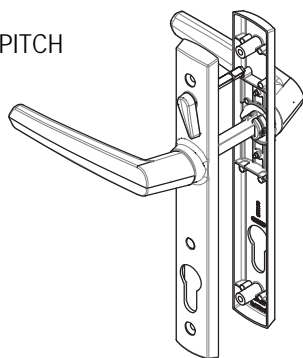

PURCHASE TO ORDER
315512 - BLACK
315521 - SATIN CHROME
315522 - SILVER
315523 - WHITE

PALLADIUM HANDLE KIT
SUMMIT L1
DOUBLE CYLINDER
EACH - 85mm PITCH
(SPD02618)

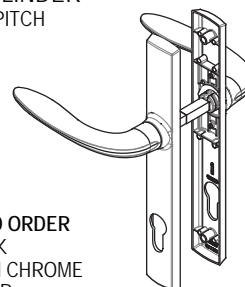

PURCHASE TO ORDER
313682 - BLACK
315508 - SATIN CHROME
313684 - SILVER
315509 - WHITE

PALLADIUM HANDLE KIT
SUMMIT L1
INTERNAL CYLINDER
EACH - 85mm PITCH
(SPD02618)

PURCHASE TO ORDER
313740 - BLACK
313741 - SILVER
315604 - WHITE

Components

Not To Scale

NON STOCKED COMPONENTS

DOUBLE SIDED TAPE



AUTOMATED SLIDING DOOR KIT
EL301 (1A201107)
(SINGLE PANEL)

CLOSED CELL BACKING ROD



AUTOMATED SLIDING DOOR KIT
TS301
(DOUBLE PANEL)

NON STOCKED ITEM
3570 MORTICE LOCK (60mm BS)
WITH 4600 SERIES HANDLE

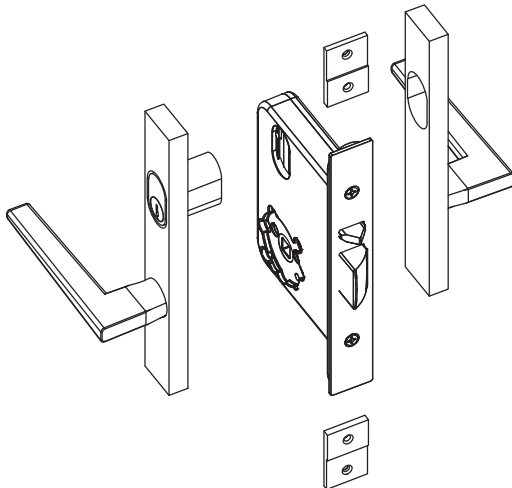

WIDE STILES ONLY
REFER TO 'SINGLE POINT LOCK' SPAN TABLES IN SECTION 2 FOR USE

NON STOCKED ITEM
STILE COVER PLATE
(40 x 32 x 0.6mm THICK) or
(40 x 29 x 0.6mm THICK)

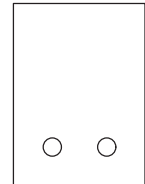

USE WITH 300372

NON STOCKED ITEM
STRIKE PLATE & STRIKE BOX

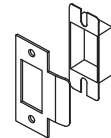

USE WITH 3750 MORTICE LOCK

Components - Lock Fitment

LOCKS		Hinged Door	Pivot Door	Sliding Door	Lock Stile	Radius Stile	Wide Lock Stile	Wide Radius Stile	Meeting Stile	Cover Stile
	Description	Part No.								
OPTIMUM	2-Point 30mm Backset *	315501	✓			✓		✓	✓	✓
	4-Point 30mm Backset	315502	✓			✓		✓	✓	✓
	4-Point 40mm Backset	316483	✓					✓		
	Ari Handle Kit 30mm Backset *	316491			✓	✓		✓	✓	✓
	Roller Bolt 40mm Backset *	319592		✓				✓		
	Sliding Lock 30mm Backset	319582			✓	✓		✓	✓	✓
	Lever Compression Lock	307388	✓			✓		✓		
3541 *	Lever Handle	311516	✓	✓	✓	✓		✓		
	Turn Knob	314469	✓	✓	✓	✓		✓		
	Double Cylinder	314468	✓	✓	✓	✓		✓		
SELECTOR *	Cylinder & Knob 23mm Backset	315947	✓			✓	✓	✓	✓	✓
	Single Cylinder 23mm Backset	315948	✓			✓	✓	✓	✓	✓
	Double Cylinder 23mm Backset	315956	✓			✓	✓	✓	✓	✓
	Cylinder & Knob 30mm Backset	319492	✓					✓	✓	
	Single Cylinder 30mm Backset	319491	✓					✓	✓	
	Double Cylinder 30mm Backset	319492	✓					✓	✓	
	Selector Face Mounted 30mm Backset	** NOTE **	✓			✓		✓		✓
SYNERGY	Synergy 3570	** NOTE **	✓					✓	✓	
	Synergy 3582 (3580 Electric Similar)	** NOTE **	✓			✓		✓		✓
	Synergy 4582 (4580 Electric Similar)	** NOTE **	✓			✓	✓	✓	✓	✓
	Synergy 5582 (5580 Electric Similar)	** NOTE **	✓				✓	✓	✓	
	Synergy 6582 (6580 Electric Similar)	** NOTE **	✓					✓	✓	

* Refer to Section 2 Span Tables for Hinge & Pivot 'Single Point Lock' usage
 ✓ Consider Handle Furniture / Key Clearance to Door Stop (Tight Scenario)

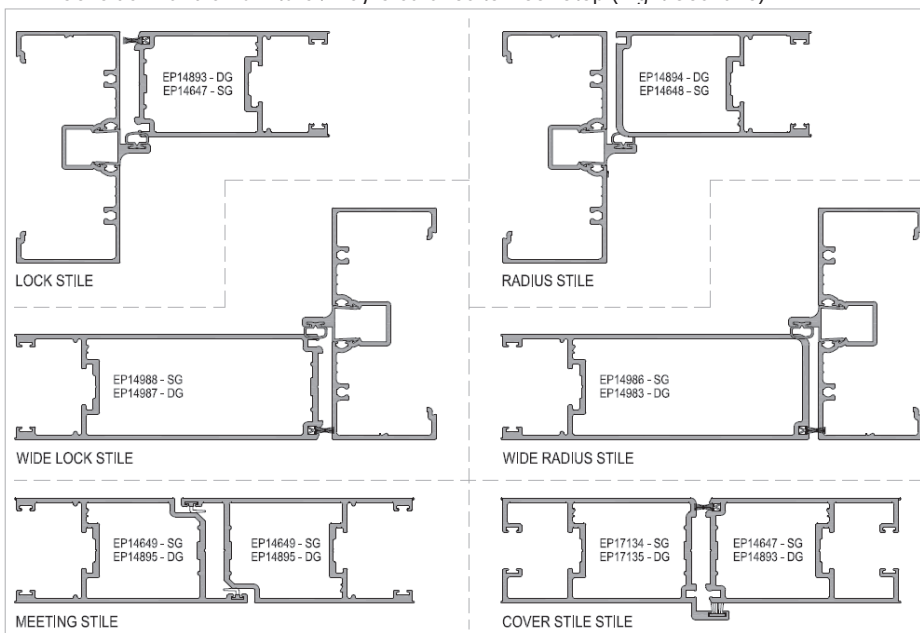

**** IMPORTANT NOTE ****

When fitting Locks that are not stocked or shown in the technical manual the following needs to be taken into consideration;
 - The fabricator needs to ensure that any alternative lock they intend to use is equivalent in strength to hold the door panel closed under the required wind loadings. Capral AGS 225 Series Door test data needs to be referenced.

Cutting Formula and BOM - Door Panel

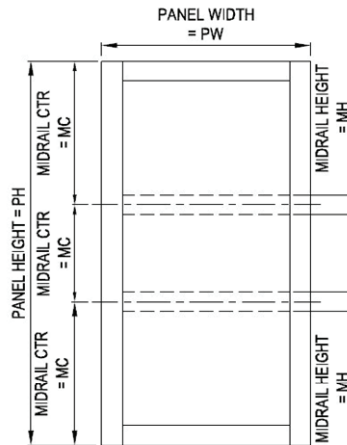

NOTE: TO BE USED IN CONJUNCTION WITH THE FOLLOWING PAGES. PANEL HEIGHT & WIDTH TO BE DETERMINED BY CONFIGURATION TYPE.

RAIL HEIGHTS (RH)		MIDRAIL HEIGHTS (MH)			
Standard Rails	110	Std Midrails	110	Std / Std	220
Shallow Rails	87	50mm Midrails	50	Extended / Shallow	227
Extended Rails	140	Shallow / Shallow	174	Extended / Std	250
		Shallow / Std	197	Extended / Extended	280

CUTTING FORMULAS			225	
HEIGHTS	Description	Section	Formula	Quantity
	Stile	-	PH	2
	Thick Glass Adaptor	EP14925	GLASS H + 14	2
	Finger Pull - Optional (SG Only, Alt. bead cutting Ref. Section 6)	EP10457	GLASS H - 24	1 or 2

	Description	Section	Formula	Quantity	
	** Subtract further 22 for each Finger Pull (SG Only)				
WIDTHS	DG Bead	EPD0224	STD STILE = PW - 164**	2	
	SG & TG Bead	EPD0223	WIDE STILE = PW - 260**		
	SG Rail	EP18288	STD STILE = PW - 164 WIDE STILE = PW - 260	2	
	SG Shallow Rail	EP18289			
	SG Extended Rail	EP18354			
	DG Rail	EP18287			
	DG Shallow Rail	EP18286			
	DG Extended Rail	EP18353			
	MIDRAIL - OPTIONAL				
		DG Bead	EPD0224	STD STILE = PW - 164**	2 per Midrail
	SG & TG Bead	EPD0223	WIDE STILE = PW - 260**		
	SG 50mm Midrail	EP17152	STD STILE = PW - 164 WIDE STILE = PW - 260	As Req.	
	TG 50mm Midrail	EP17153			
	DG 50mm Midrail	EP17154			
	SG Midrail	EP14904			
	DG Midrail	EP14903			
	174mm Coupled Midrail	2 x Shallow Rail + EP16765			
	197mm Coupled Midrail	Rail + Shallow Rail + EP16765			
	220mm Coupled Midrail	2 x Rail + EP16765			
	227mm Coupled Midrail	Shallow Rail + Extended Rail + 2 x EP16765			
	250mm Coupled Midrail	Rail + Extended Rail + 2 x EP16765			
	280mm Coupled Midrail	2 x Extended Rail + 3 x EP16765			
ADDITIONAL FOR FINGER PULL					
	SG & TG Bead	EPD0223	22	2 for each Finger Pull	

	Description	Section	Formula	Quantity	
	** Subtract further 22 for each Finger Pull (SG Only)				
GLASS	Glass	Height		1	
		Width	Std Stile		PH - 2RH + 24
			Wide Stile		PW - 142**
	Top OR Bottom		MC - RH - MH/2 + 24	As Req.	
Middle	-	MC - MH + 24			

Please read in conjunction with Important Conditions – Index (also available on Capral website)

Cutting Formula and BOM - Door Panel

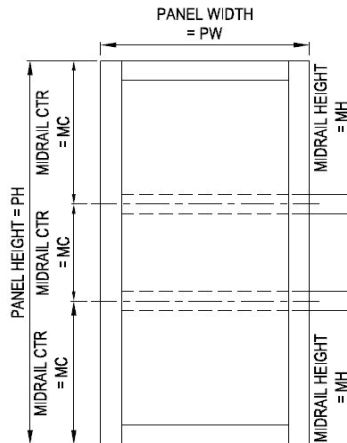

BILL OF MATERIALS		225	
Description	Part No.	UOM*	Quantity
Glazing Wedge	Ref. Sec. 4 & 7	mm	2PH + 2PW [^]
1.2mm Backing Gasket	306908	mm	2PH + 2PW [^]
4mm Backing Gasket	306905		
Glazing Wedge 7mm Gap	306909		
Glazing Wedge 8mm Gap	300004		
8g x 45mm PAN Screw (197mm or 220mm Coupled Midrail)	307155	each	2 per 197mm or 220mm Coupled Midrail
EURO BRACKET ASSEMBLY			
Euro Rail Fixing Bracket	315483	each	4 ^{^^}
Gutter Seal	323403	mm	Rail Length
SPIGOT ASSEMBLY			
SG Spigot Kit	322183	Set	4
DG Spigot Kit	322182		
Gutter Seal	323403	mm	DG Rail Length + 36.5 SG Rail Length - 84
TIE ROD ASSEMBLY			
M8 S/S All Thread Tie Rod	Non-Stocked	mm	Rail Length + 110
SG Spigot Kit	322183	Set	4
DG Spigot Kit	322182		
Gutter Seal	323403	mm	DG Rail Length + 36.5 SG Rail Length - 84
JACKING SCREW HEEL & TOE GLAZING			
8mm Glass Setting Block	317200	each	1 ^{^^}
Jacking Screw	316486	each	3 ^{^^}
SG Jacking Screw Foot	315487	each	3 ^{^^}
DG Jacking Screw Foot	315488		
Hole Plug	309327	each	3 ^{^^}
BLOCK HEEL & TOE GLAZING			
8mm Glass Setting Block	317200	each	2 ^{^^}
8g x 15mm PAN Screw	301086	each	1 ^{^^^}
Glass Support Block	322233	each	2 ^{^^}

* Part Number may not reflect Unit of Measure (UOM)

[^]Additional 2PW for each midrail

^{^^} Additional 2 Qty. for each Midrail OR 4 Qty. for each coupled midrail

^{^^^} one additional Qty. for each midrail

Cutting Formulas and BOM - Aluminium Slat Door Panels

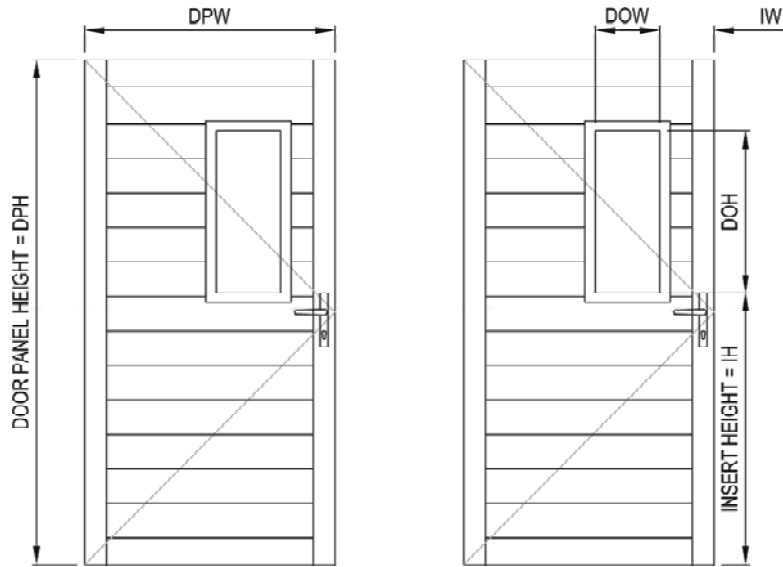

NOTE: THE BELOW FORMULAS TO BE USED IN CONJUNCTION WITH 'DOOR PANEL' FORMULAS. REPLACES 'DOOR PANEL' GLASS

RAIL HEIGHTS (RH)	STANDARD	SHALLOW	EXTENDED
	110	87	140

HEIGHTS BASED ON FULL SLATS SH = Qty of Slats x 92 or 100	INSERT HEIGHT (IH)	DAYLIGHT HEIGHT (DOH)	PANEL HEIGHT (PH)
	SH + BOTTOM RH + 13	SH - 42	SH + 2RH - 20

SLAT HEIGHT BASED ON PH / IH divide by 92 or 100 to determine slat qty	UNDER INSERT	FULL PANEL	ABOVE INSERT
	IH - BOTTOM RH - 9	PH - 2RH + 20	PH - IH - BOTTOM RH - 9

CUTTING FORMULAS

SLATS	Description	Section	Quantity	Std Stile Formula	Wide Stile Formula
	Panel 92 x 12mm	EPD0121	Full Width		PW - 144
Panel 100 x 12mm	EPD0217	IW Side		IW - 91	IW - 139
		Other side		PW - IW - DOW - 91	PW - IW - DOW - 139

INSERT	Description	Section	Formula		
	Slat Glazing Frame	EPD0122	Height	DOH + 74	
			Width	DOW + 74	
	Glass		Height	DOH + 18	
Width			DOW + 18		

BILL OF MATERIALS

COMPONENTS	Description	Part No.	UOM*	Quantity
	1.2mm Backing Gasket	306905	mm	2H + 2W
	Glazing Wedge 3mm Gap	306910	mm	2H + 2W
	6mm Glazing Channel	300031	mm	2DOH + 2DOW
	Fin Pressure Seal	301296	mm	4DOW + 4DOW
	Corner Cleat	306653	each	4

* Part Number may not reflect Unit of Measure (UOM)

Cutting Formula and BOM - Louvre Panel

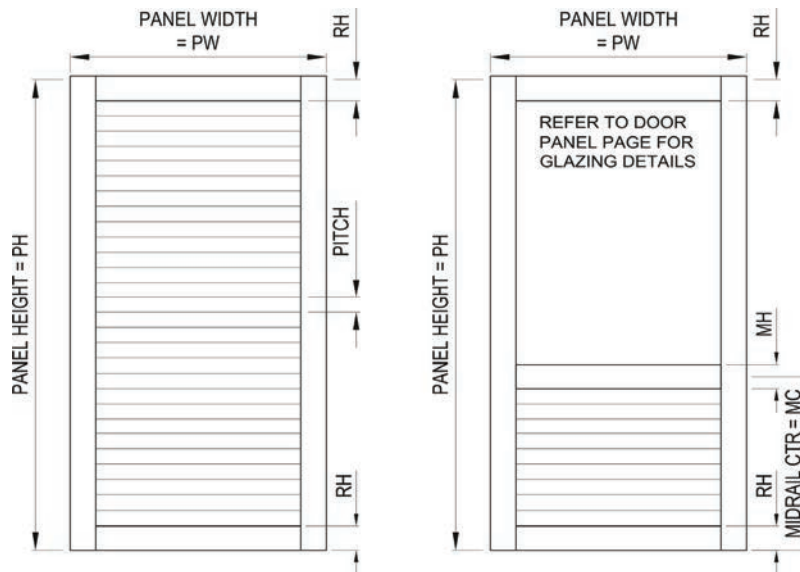

NOTE: THE BELOW FORMULAS TO BE USED IN CONJUNCTION WITH 'DOOR PANEL' FORMULAS. REPLACES 'DOOR PANEL' GLASS
PANEL HEIGHT (PH) = (NUMBER OF LOUVRES X PITCH) + (LOUVRE HEIGHT - PITCH) + 2RH + 4
MIDRAIL CCTR (MC) = (NUMBER OF LOUVRES X PITCH) + (LOUVRE HEIGHT - PITCH) + RH + 4 + (MH / 2)

CUTTING FORMULAS		LOUVRE PANEL		
HEIGHT	Description	Section	Formula	Quantity
	Louvre Adaptor - Full Panel	EP17096	PH - 2RH - 4	2
	Louvre Adaptor - To midrail		MC - RH - (MH/2) - 4	

WIDTHS	Description	Section	Formula	Quantity
	Rail Louvre Adaptor	EN3597	STD STILE = PW - 166 WIDE STILE = PW - 262	2
	63 x 46mm Blade	EL2096	STD STILE = PW - 188	AS REQ.
	62 x 48mm Throated Blade	EN4023	WIDE STILE = PW - 284	

BILL OF MATERIALS		LOUVRE PANEL		
COMPONENTS	Description	Part No.	UOM*	Quantity
	Louvre Seal	309644	mm	4 RAIL WIDTH
	10g X 25mm PAN Screw	300059	each	4 per Louvre
	8g x 45mm PAN Screw	309155	each	2 x 400 CTRS
	Hole Plug	309327	each	2 x 400 CTRS

* Part Number may not reflect Unit of Measure (UOM)

Cutting Formula and BOM - Hinged Door

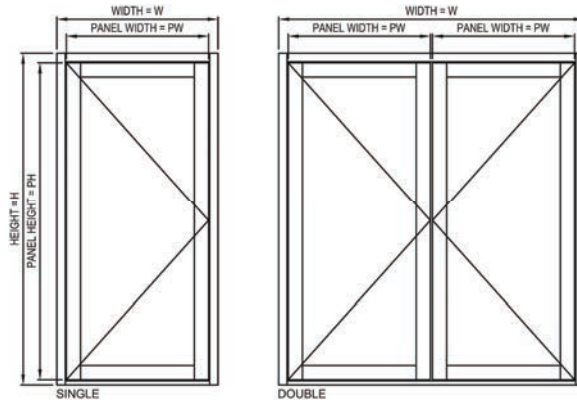

PANEL HEIGHT (PH) = H - FRAME HEIGHT - SILL HEIGHT - 5
 SINGLE PANEL WIDTH (PW) = W - 2 x FRAME HEIGHT - CLEARANCE WIDTH
 DOUBLE PANEL WIDTH (PW) = (W - 2 x FRAME HEIGHT) / 2 - CLEARANCE WIDTH

CLEARANCE WIDTH - Single Door	Hinge Type 1	Hinge Type 2	Hinge Type 3	311259 Hinge
Selector Lock	6.5	7	7.5	8.5
Optimum Lock	8.5	9	9.5	9.5
Lever Compression Lock (LCL)	10.5	11	11.5	11.5
3541 Mortice Lock	7	7.5	8	8.5

Hinge Type 1
310523
320167
Hinge Type 2
300378
317231
Hinge Type 3
317649
317662

CLEARANCE WIDTH - Double Door	Hinge Type 1	Hinge Type 2	Hinge Type 3	311259 Hinge
Meeting Stiles - Optimum Lock	4.5	5	5.5	5
Cover Stiles - Selector Lock	4.5	5	5.5	5.5
Cover Stiles - Optimum Lock	5.5	6	6.5	6
Cover Stiles - LCL	6.5	7	7.5	7
Cover Stiles - 3541 Mortice Lock	4.75	5.25	5.75	5.5

SILL HEIGHTS (SH)		OPEN OUT	OPEN IN	FRAME HEIGHTS (FH)	
76 x 22mm	E35737	25	27	300 & 325 Narrowline	35
101.6 x 12.7mm	E01854	20.5	20.5	400 & 601 Narrowline	44
101.6 x 20mm	EP2365	25	25	600, 425 & 625 Narrowline	50
101.6 x 25mm	EP2212	25	30	450 Narrowline	55
100 & 150mm Ramped	EP13539 & EP13540	14	20	419 SG Flushline	50
100 x 45mm Open In	EP15939		35.5	419 DG Flushline	55
100 & 150 x 44mm	EP2366 & EP5796	19	19		
No Threshold	-	8	8		
Threshold Notch Height (TNH)	Ref. Sec 5, Page 3		MITRE HEIGHT (MH)	Ref. Sec 2, Page 7	

CUTTING FORMULAS				
	Description	Section	Formula	Quantity
HEIGHTS	Jamb	-	H	2
	Door Stop - Notched at Head & Threshold	-	H - FH	2
	Door Stop - Mitred at Head & Notched at Threshold	-	H - FH + MH	
	Door Stop - Notched at Head & Square Threshold	-	H - FH - TNH	
	Door Stop - Mitred at Head & Square Threshold	-	H - FH - TNH + MH	
	Plant On Door Stop	EL6478	H - FH - TNH	
	Flush Filler - Square Threshold	-	TNH	2
	Flush Filler - Plant On Door Stop	-	H	2
	Meeting Stile Adaptor - Double Door Only as Required	EP1546	PH	1

Cutting Formula and BOM - Hinged Door

CUTTING FORMULAS				
	Description	Section	Formula	Quantity
WIDTHS	Head	-	$W - 2FH$	1
	Threshold	-	$W - 2FH$	1
	Door Stop - Notched at Head	-	$W - 2FH$	1
	Door Stop - Mitred at Head	-	$W - 2FW + 2MH$	
	Plant On Door Stop - Notched at Head	EL6478	$W - 2FH - 6$	
	Plant On Door Stop - Mitred at head		$W - 2FH$	
	Weather Strip - Single Door	EPD0284	$OO = PW - 27$	1
	Weather Strip - Double Door		$OO = PW - 29 \& PW - 34$ $OI = PW - 7$	2

BILL OF MATERIALS				
FRAME COMP.	Duoseal Door Stop 3mm	300021	mm	$2H + W^{\wedge}$
	Duoseal Door Stop 5mm	300022		
	Door Stop 5mm	300032		
	Door Stop 7mm	300023		
	Acoustic Door Stop 5mm	302444		
	OPEN IN THRESHOLD EP15939			
	215 Open In Sill Adaptor (215 only)	317665	mm	$W - 2FH$
	8g x 10mm PAN Screw (215 only)	300061	each	$W/450 + 1$
	11mm Polypile	301865	mm	W
	Sill Flap	300027	mm	W

[^] 1 additional W when using Open Out Thresholds

GENERAL				
PER PANEL COMPONENTS	Weather Strip Clip	308233	mm	PW
	Polypile 8mm - Radius Stile at Hinge Only	317191	mm	PH
	Polypile 11mm - Lock Stile at Jamb Only	301865	mm	2PH
	Polypile 8mm	317191	mm	PW
	Polypile 11mm	301865		
	Polypile 13mm	300045		
	Weather Strip Cap LH	308232	each	1
	Weather Strip Cap RH	308231	each	1
	Aluminium Hinge	300378	each	3 - 6**
	Aluminium Fast Fix Hinge ■	317662		
	Aluminium Fast Fix In Line Hinge	317649		
	S/Steel Fast Fix Hinge	310526		
	Parliament Hinge ■	311259		
	Adjustable Hinge ■	317231		
OPTIONAL				
7714 H/O Door Closer	316121	each	1	
7714 Slide Rail Closer	316122			
7724 H/O Door Closer	316123			
7724 Slide Rail Closer	316124			
2615 Opening Dampener	317648	each	1	

** Refer to Section 4 and fabricator specifications for further details

■ Radius Stiles Only

◆ Refer to Lock Fitment page in Section 4 for compatibility

* Part Number may not reflect Unit of Measure (UOM)

Cutting Formula and BOM - Hinged Door

BILL OF MATERIALS		SINGLE DOOR		DOUBLE DOOR	
Description	Part No.	UOM*	Quantity	UOM*	Quantity
GENERAL					
Polypile 11mm	301865	mm	2PH		
Co-Extruded Fin Seal - Meeting Stiles	314416			mm	2PH
Woolpile 6mm - Cover Stile	322122			mm	PH
Polypile 11mm - Cover Stile	301865			mm	PH
SELECTOR LOCK ♦					
23mm BS Lock Set	Ref. Sec.4	each	1	each	1
30mm BS Lock Set	Ref. Sec.4				
OPTIMUM 2-POINT ♦					
Optimum 2-Point Lock Kit	315501	each	1	each	1
Palladium / Caprio Handle	Ref. Sec.4	each	1	each	1
Lock Cylinder 75mm	Ref. Sec.4	each	1	each	1
Central Strike LH	307747	each	1	each	1
Central Strike RH	307633				
Meeting Strike LH - Double Door Only	317198				
Meeting Strike RH - Double Door Only	317197				
Recessed Flush Bolt (Optional)	300380			each	2
Flush Bolt Guide (Optional)	301744			each	2
OPTIMUM 4-POINT ♦					
30mm BS Optimum 4Point Lock Kit	315502	each	1	each	1
40mm BS Optimum 4Point Lock Kit	316483				
Palladium / Caprio Handle	Ref. Sec.4	each	1	each	1
Lock Cylinder 75mm	Ref. Sec.4				
Stile End Cap	317401	each	2	each	4
Strike LH	307747	each	1	each	1
Strike RH	309633				
Meeting Strike LH - Double Door Only	317198				
Meeting Strike RH - Double Door Only	317197				
Lock Rods	308305	each	1	each	1
S/Steel Rod Tips	317201	each	1	each	1
4 point Bolt Extension Kit (Doors above 2.4m High)	305729	each	1	each	1
Surface Flush Bolt	Ref. Sec.4				
Flush Bolt Guide	301744			each	2
LEVER COMPRESSION LOCK ♦					
LCL Lock	313761	each	1		
LCL Strike Set LH	307632	each	1		
LCL Strike Set RH	307746				
Palladium / Caprio Handle	Ref. Sec.4	each	1		
3541 MORTICE LOCK ♦					
Lever Handle	311516	each	1	each	1
Turn Knob	314469				
Double Cylinder	314468				
Strike	314636				

COMPONENTS

Cutting Formula and BOM - Pivot Door

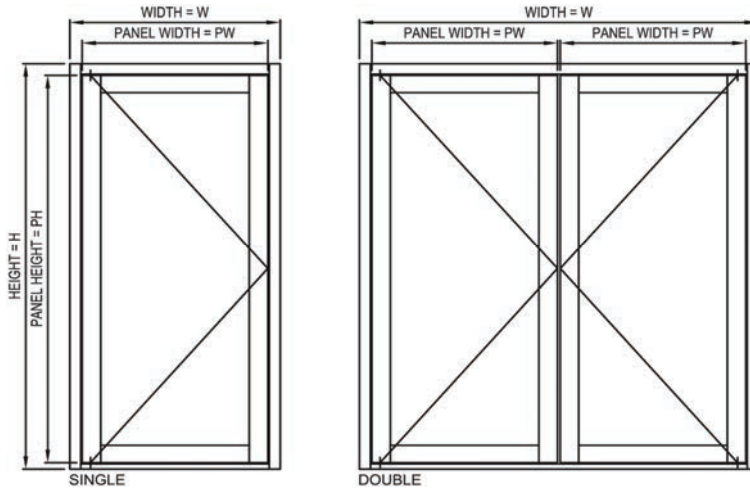

PANEL HEIGHT (PH) = H - SILL HEIGHT - 53 SINGLE PANEL WIDTH (PW) = W - 2 x FRAME HEIGHT - 8 DOUBLE PANEL WIDTH (PW) = (W - 2 x FRAME HEIGHT) / 2 - 6					
SILL HEIGHTS (SH)			FRAME HEIGHTS (FH)		
101.6mm x 12.7mm	E01854	20.5	300 & 325 Narrowline	35	
101.6mm x 20mm	EP2365	25	400 & 601 Narrowline	44	
150mm Ramped	EP13540	21	600, 425 & 625 Narrowline	50	
No Threshold	-	8	450 Narrowline	55	
			419 SG Flushline	50	
			419 DG Flushline	55	

CUTTING FORMULAS - FRAME				
HEIGHT	Description	Section	Formula	Section
	Jamb	-	H	2
	Flush Filler	-	H	2

WIDTHS	Description	Section	Formula	Section
	COC Head	-	W - 2FH	1
	Threshold	-	W - 2FH	1

BILL OF MATERIALS			SINGLE		DOUBLE	
COMPONENTS	Description	Part No.	UOM*	Quantity	UOM*	Quantity
		9800 Concealed Overhead Closer	Ref. Sec.4	each	1	each
	Polypile 13mm (Std Meeting Stile)	300045			mm	2PH
	Polypile 8mm (Alt. Meeting Stile)	317191				
	Polypile 11mm	301865	mm	4PH	mm	4PH
	3541 MORTICE LOCK					
	Lever Handle	311516				
	Turn Knob	314469	each	1	each	1
	Cylinder	314468				
	Latching Strike	314636	each	1	each	1
	Recessed Flush Bolt	300380			each	2
	Flush Bolt Guide	301744			each	2
	OPTIMUM LOCK					
	Optimum Roller Bolt 40mm BS	319592	each	1	each	1
	Strike LH	307633	each	1		
	Strike RH	307747				
	Meeting Strike LH	317197			each	1
	Meeting Strike RH	317198				
	Caprio Escutcheon	317691	each	1	each	1
	800mm Pull Handle **	317693				
	Push Pull Handle Set **	316413	each	1	each	2

* Part Number may not reflect Unit of Measure (UOM)

** Can also be used as an optional alt. with 3541 Mortice Lock

^ Additional W when using Open Out Thresholds

Please read in conjunction with Important Conditions – Index (also available on Capral website)

Cutting Formula and BOM - Basic Sliding Door

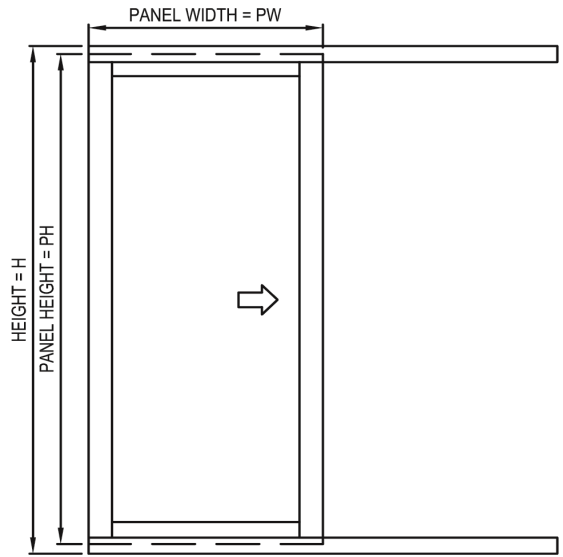

PANEL HEIGHT		
SINGLE TRACK	PANEL HEIGHT (PH)	PANEL WIDTH (PW)
1022 Sliding Floor Track	H - 37	AS REQ. REFER TO Sec2 FOR LIMITATIONS
1021 Sliding Floor track	H - 28	
1030 Sliding Head Roller	H - 108	
1031 Sliding Head Roller	H - 93	
1061 Sliding Head Roller	H - 80.5	

NOTE: Refer to section 6 for section/hardware combination examples

Cutting Formula and BOM - Double Track Sliding Door

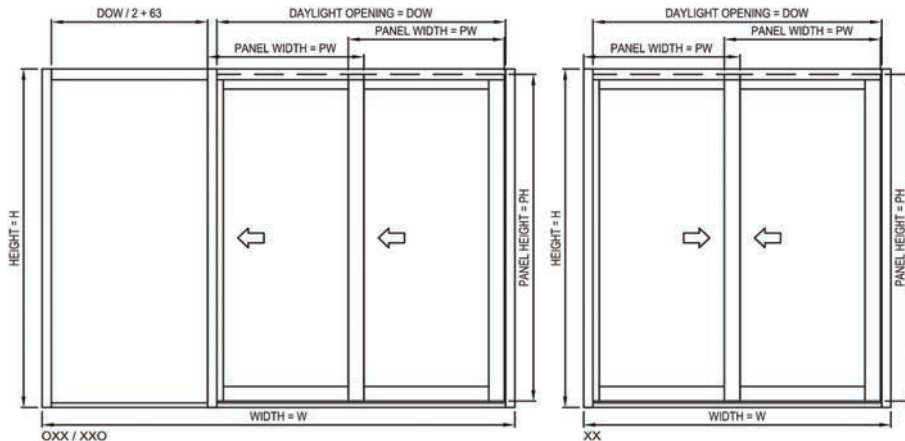

PANEL HEIGHT & WIDTH		
SINGLE TRACK	PANEL HEIGHT (PH)	PANEL WIDTH (PW)
OXX / XXO Configuration	H - 28.5	DOW / 2 + 61
XX Configuration		DOW / 2 + 36

CUTTING FORMULAS		OXX		XX	
	Description	Section	Formula	Section	Formula
HEIGHT	Narrowline Frame	-	H	4	H
	Narrowline Flush Filler	-	H	2	H
	Narrowline Flat Filler	EN5028	H	1	
	Interlock Adaptor	EL5387	PH	3	PH
			H	1	2

	Description	Section	Formula	Section	Formula
WIDTHS	Double Slider Head	EK9075	$3(DOW / 2) + 107$	1	DOW
	1022 Slider Track	EP0892	$3(DOW / 2) + 107$	2	DOW
	Narrowline Head	-	DOW / 2 + 63	1	
	Narrowline Sill	-	DOW / 2 + 63	1	
	Narrowline Bead	-	DOW / 2 + 63	1	

BILL OF MATERIALS		OXX		XX		
	Description	Part No.	UOM*	Quantity	UOM*	
COMPONENTS	1022 Floor Roller	300376	each	4	each	
	Guide Button	300248	each	8	each	
	Rubber Grommet	306961	each	1	each	
	Bumper	311558	mm	46mm		
	Woolpile	322122	mm	2PH		
	Polypile 11mm	301865	mm	PH	mm	
	Polypile 13mm	300045	mm	2PH	mm	
	3541 MORTICE LOCK					
	Lever Handle	311516				
	Turn Knob	314469	each	1	each	
	Double Cylinder	314468				
	Strike	314636	each	1	each	
	Strike Adaptor	300385	each	1	each	
	OPTIMUM					
	Optimum Sliding Lock 30mm Backset	319582				
	Optimum Sliding Strike	319593	each	1	each	
	Caprio Escutcheon	317691				
	800mm Pull Handle **	317693	each	1	each	
Flush Pull **	317691					
OPTIMUM MORTICE						
Mortice Lock & Aria Handle Kit	316491	each	1	each		
Receiver Cover	317043	each	1	each		

* Part Number may not reflect Unit of Measure (UOM)

** Optional alt. with 3541

Cutting Formula and BOM - Flushline XO Sliding Door

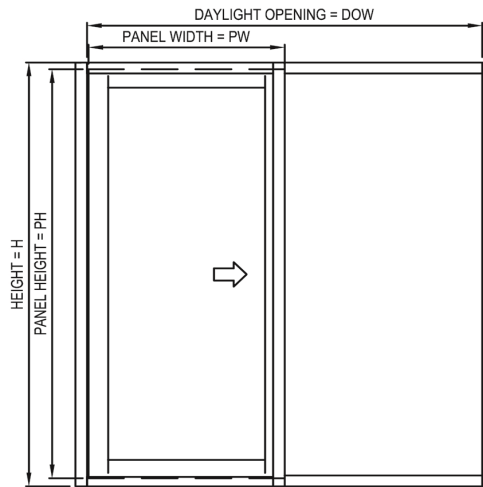

PANEL HEIGHT & WIDTH				
SINGLE TRACK	PANEL HEIGHT (PH)		PANEL WIDTH (PW)	
OX / XO Configuration	H - 53		SG = DOW / 2 + 20	DG = DOW / 2 + 22.5

CUTTING FORMULAS				XO	
HEIGHT	Description	SG Section	DG Section	Formula	DG Section
	150mm Flushline Frame	EP2214	EP7709	H	2
	100mm Flushline Frame	EP2213	EP16297	H - Head Height	1
	Flushline Flush Filler	E19991	E34300	H	1
				H - Head Height	1
100mm Flushline Flat Filler	EP2224	EP16299	H - Head Height	1	

WIDTHS	Description	SG Section	DG Section	Formula	DG Section	
	◆ SUBTRACT FURTHER 2.5 FOR DOUBLE GLAZED					
	101.6mm X 25mm Threshold	EP0892		DOW / 2 - 25◆	1	
	50 x 6mm Flat Bar	EAL4035		DOW	1	
	100mm Flushline Sill	EP2383	EP7717	DOW / 2 - 25◆	1	
	Flushline Bead	E34084	EP7715	DOW / 2 - 25◆	1	
	40 x 25 x 3mm Angle	EK9122		100	1	
	100mm Flushline Head	EP2213	EP16279	DOW	1	
	10610 Roller Head	EN8012		DOW	1	
	Weather Strip	EPD0284		DOW / 2 - 25◆	1	

GLASS	Description			Formula	Quantity	
	SG Fixed Glass	Height			H - 82	1
		Width			DOW / 2 - 7	
	DG Fixed Glass	Height			H - 86	
		Width			DOW / 2 - 1	

Cutting Formula and BOM - Flushline XO Sliding Door

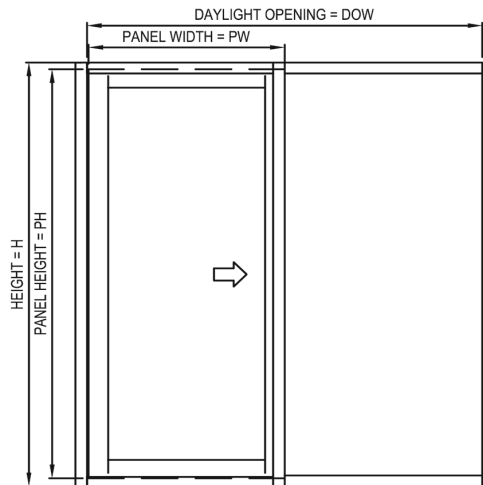

BILL OF MATERIALS		XO	
Description	Part No.	UOM*	Quantity
1061 Head Roller	300371	each	2
1061 Bracket	300372	each	2
10g x 25mm PAN Screw - Frame	300059	each	18
10g x 50mm PAN Screw - Frame at pocket	317391	each	2
10g x 50mm PAN Screw - DG Frame at pocket		each	6
Woolpile	322122	mm	DOW
Polypile 11mm	301865	mm	2PH DOW / 2 - 25♦
Weather Strip Clip	308233	mm	DOW / 2 - 25♦
Flushline Glazing Wedge	-	mm	4H + 2W
Sill Support Block	308064	each	DOW / 200 + 1
3541 MORTICE LOCK			
Lever Handle	311516	each	1
Turn Knob	314469		
Double Cylinder	314468	each	1
Latching Strike	314636		
OPTIMUM			
Optimum Sliding Lock 30mm Backset	319582	each	1
Optimum Sliding Strike	319593		
Caprio Escutcheon	317691	each	1
800mm Pull Handle **	317693		
Flush Pull **	317691		
OPTIMUM MORTICE			
Mortice Lock & Aria Handle Kit	316491	each	1
Lock Body Packer	317041	each	?
Strike Packer	317042	each	?
Receiver Cover	317043	each	1

* Part Number may not reflect Unit of Measure (UOM)

** Optional alt. with 3541

Machining - Door Stop Head Option 1 - Notched

Scale 1:2

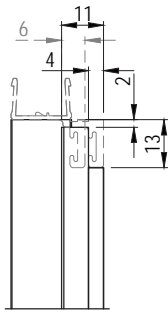

EU5003 . EU7719
300 . ALT SG NARROWLINE
DOOR STOPS

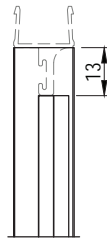

EL4053 . EK5926 . EP0903
400/601 . ALT SG
NARROWLINE DOOR STOPS

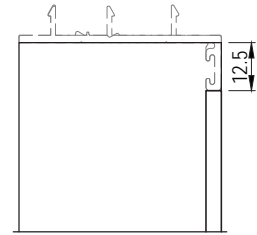

EP6047 . EP15181
419 SG . 419 DG DOOR
STOP

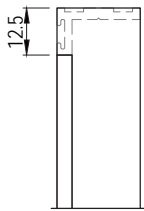

EL6478
PLANT ON DOOR STOP
(325, 600, 625)

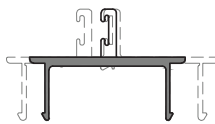
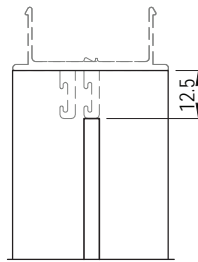

EN4016 . EP14141 . EP11906
425 . 450 . ALT DG NARROWLINE
DOOR STOPS

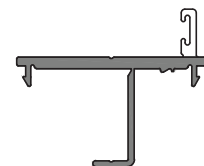
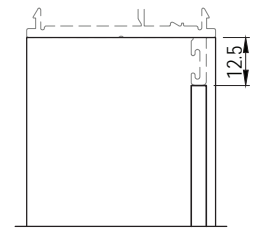

EN4016
419 50mm SASH
ADAPTOR

Please read in conjunction with Important Conditions – Index (also available on Capral website)

Machining - Door Stop Head Option 2 - Mitred

Scale 1:2

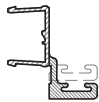
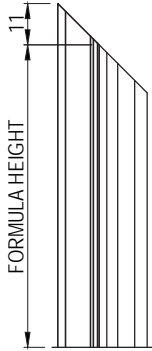

EU5003 . EU7719
300 . ALT SG NARROWLINE
DOOR STOPS



EL4053 . EK5926 . EP0903
400/601 . ALT SG
NARROWLINE DOOR STOPS



EL6478
PLANT ON DOOR STOP
(325, 600, 625)

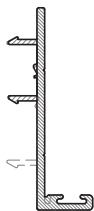
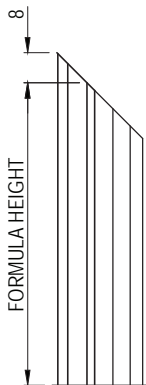

EP6047 . EP15181
419 SG . 419 DG DOOR STOP

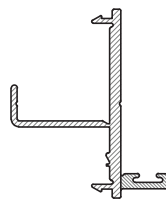
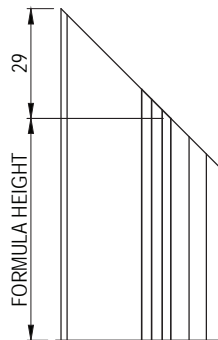

EP13363
419 50mm DOOR STOP

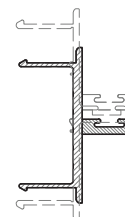
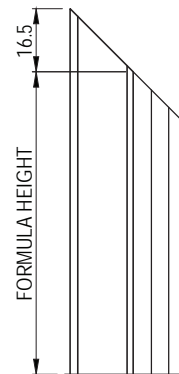

EN4016 . EP14141 . EP11096
425 . ALT 425 DOOR STOP
450 DOOR STOP

Please read in conjunction with Important Conditions – Index (also available on Capral website)

Machining - Door Stop Thresholds

Scale 1:2

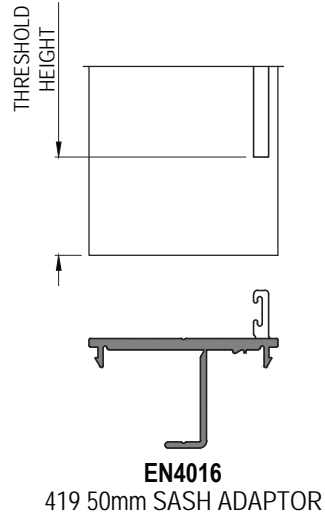
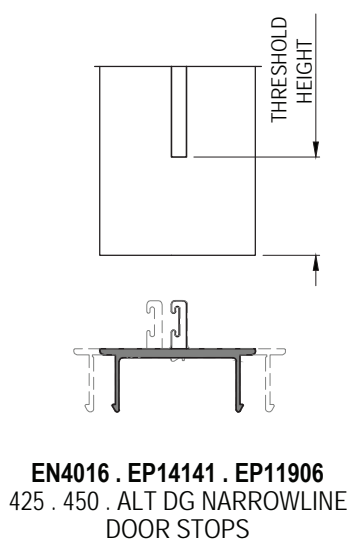
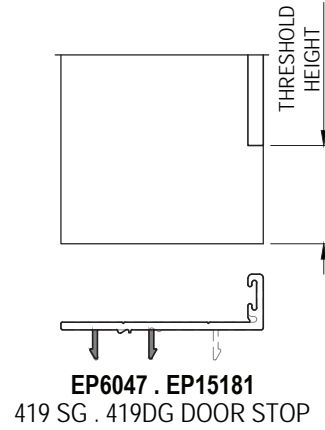
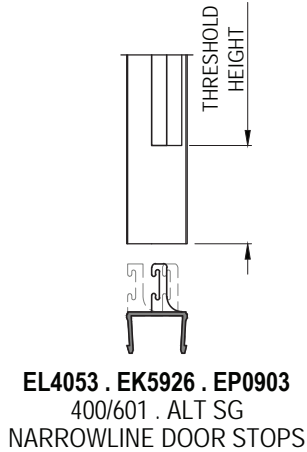
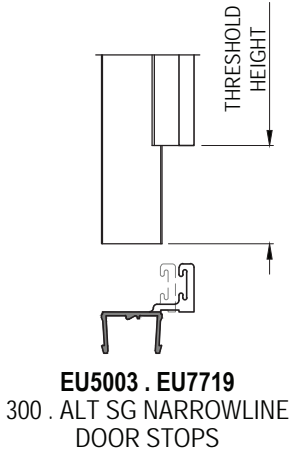

THRESHOLD NOTCH HEIGHT (TNH)		
Description	Section	TNH
76mm x 22mm Threshold	E35737	OO = 20
		OI = 15
101.6mm x 12.7mm Flat Threshold	E01854	13
101.6mm x 20mm Flat Threshold	EP2365	17
101.6mm x 25mm Threshold	EP2212	18
100mm Ramped Threshold	EP13539	10
100mm x 44mm Open Out Threshold	EP2366	44
150mm Ramped Threshold	EP13540	OO = 10
		OI = 13
150mm x 44mm Open Out Threshold	EP5796	44

Please read in conjunction with Important Conditions – Index (also available on Capral website)

Machining - Thresholds

Scale 1:2

NOTE: MACHINE HOLES THAT SUIT CHOSEN FRAME.
MACHINING SHOWN FOR ONE JAMB, MIRROR FOR JAMB ON OTHER SIDE.

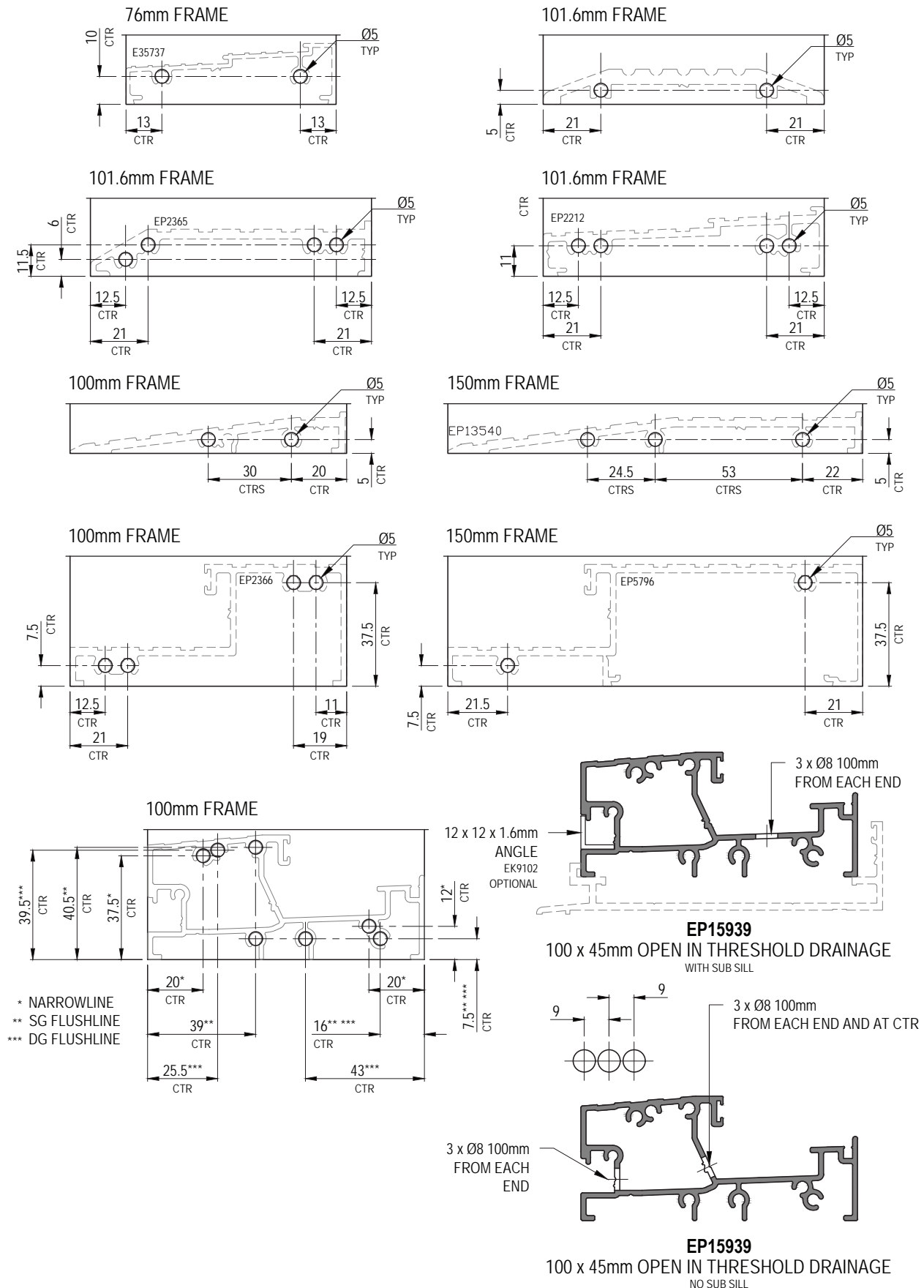

Please read in conjunction with Important Conditions – Index (also available on Capral website)

Machining - Panel Drainage & 50mm Midrail

NOTE: TOP DRAIN HOLES ONLY REQUIRED ON OPEN OUT DOOR ONLY.

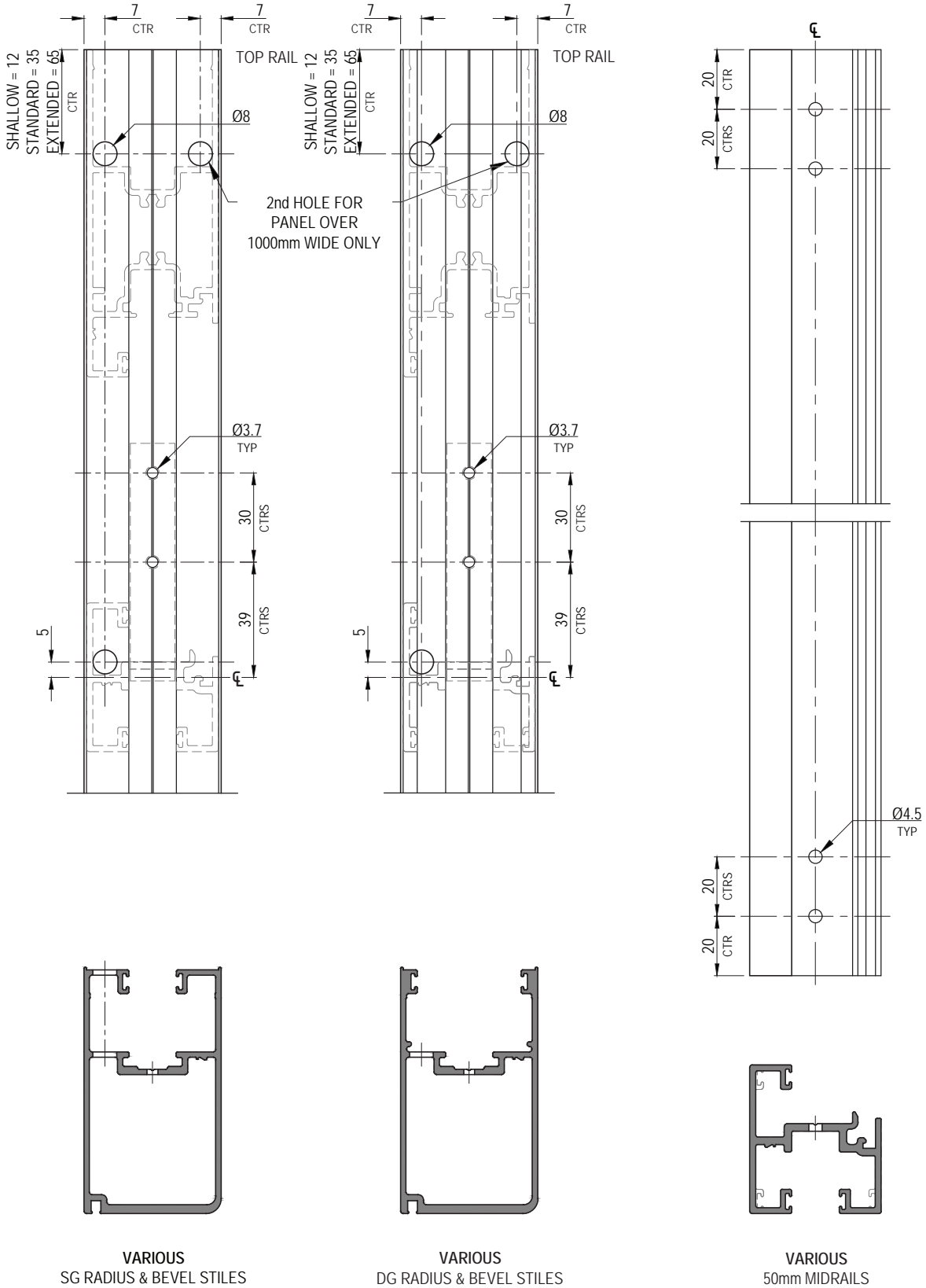

Please read in conjunction with Important Conditions – Index (also available on Capral website)

Machining - Jacking Screws & Thick Glazed Adaptor

Scale 1:2

NOTE: REFER TO Sec7 PAGES 1 - 3 FOR JACKING & GLASS SUPPORT BLOCK LOCATIONS.

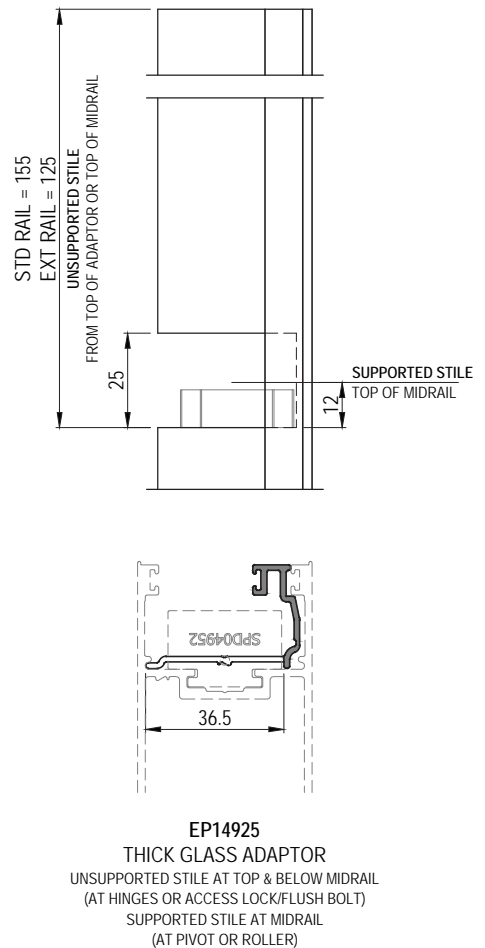
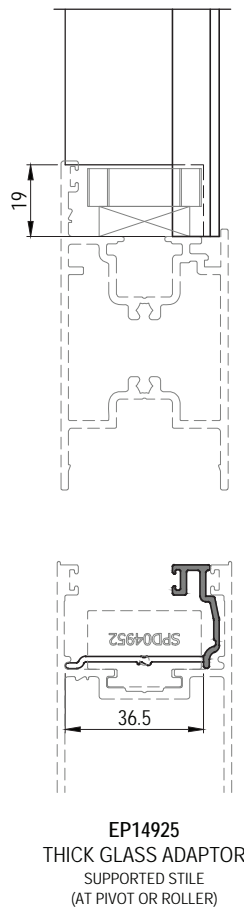
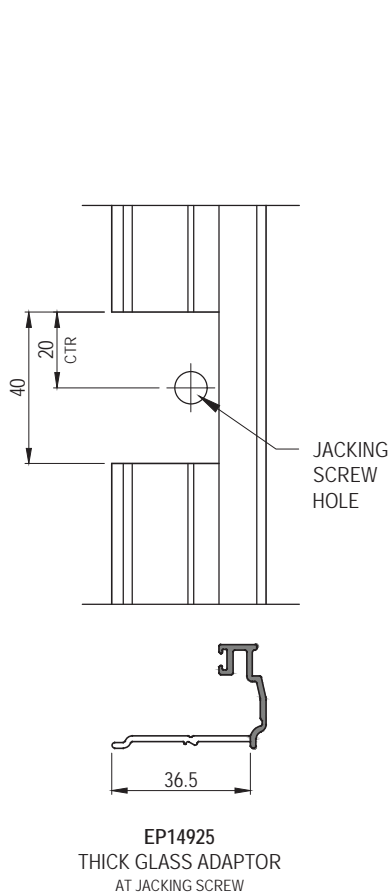
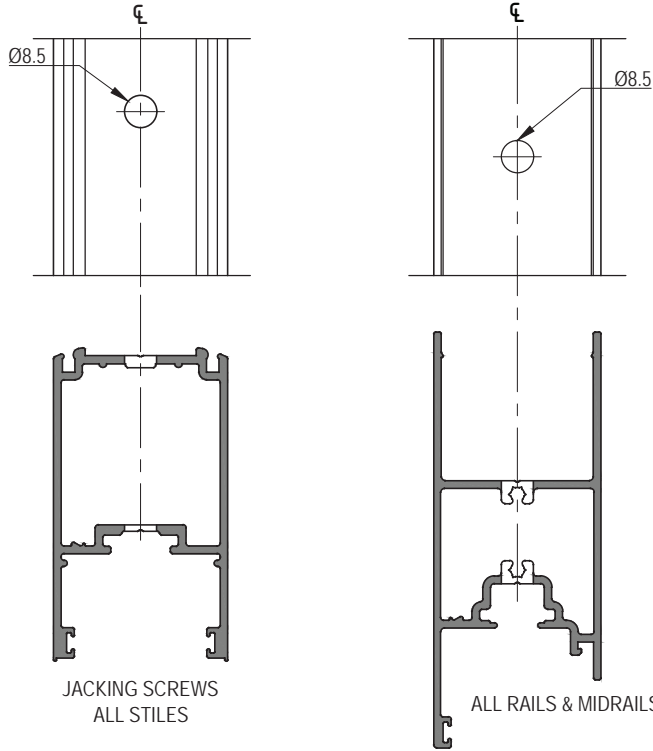

Please read in conjunction with Important Conditions – Index (also available on Capral website)

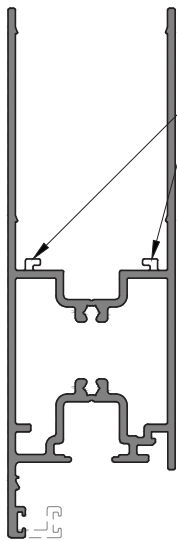

42.5mm
NOTCH OFF LEGS
AT EACH END

EP18353 . EP18354
EXTENDED RAILS

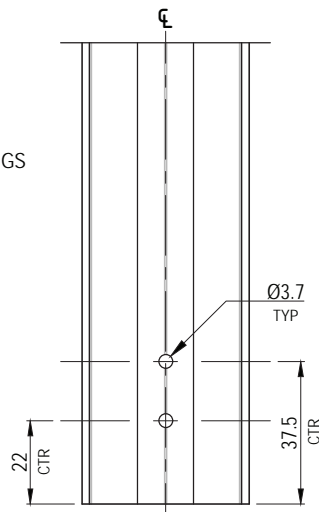

VARIOUS
SG RAILS

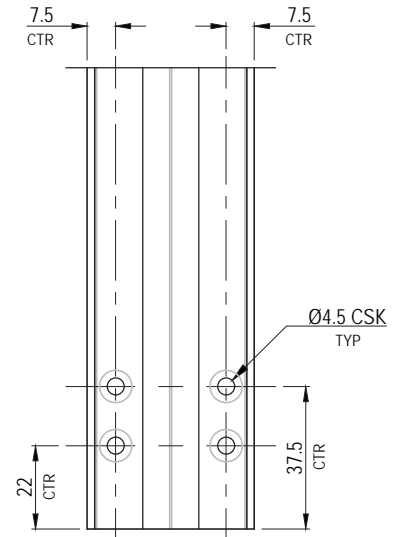

VARIOUS
DG RAILS

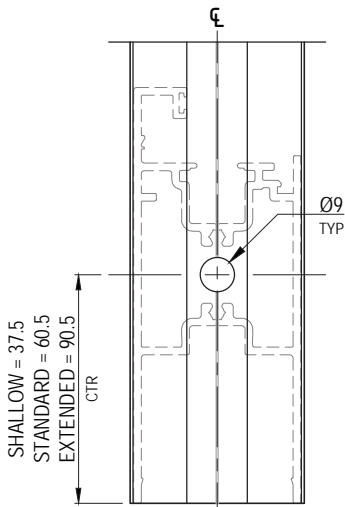

STANDARD SG RAIL SHOWN
MIRROR FOR TOP RAIL

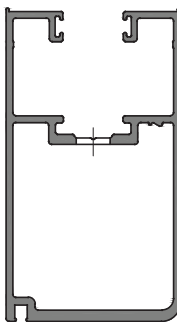

VARIOUS
ALL STILES

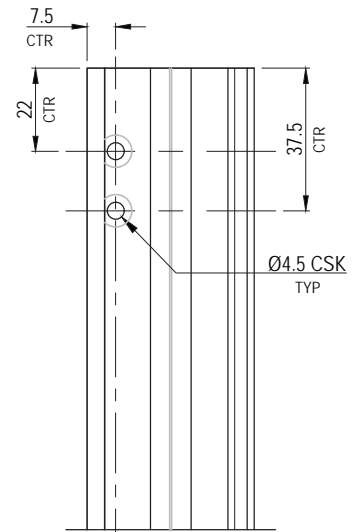
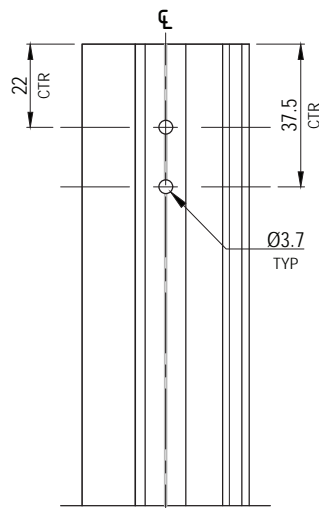

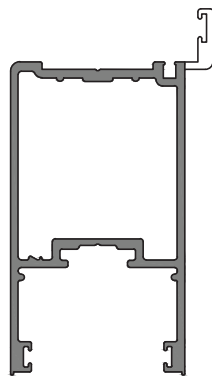
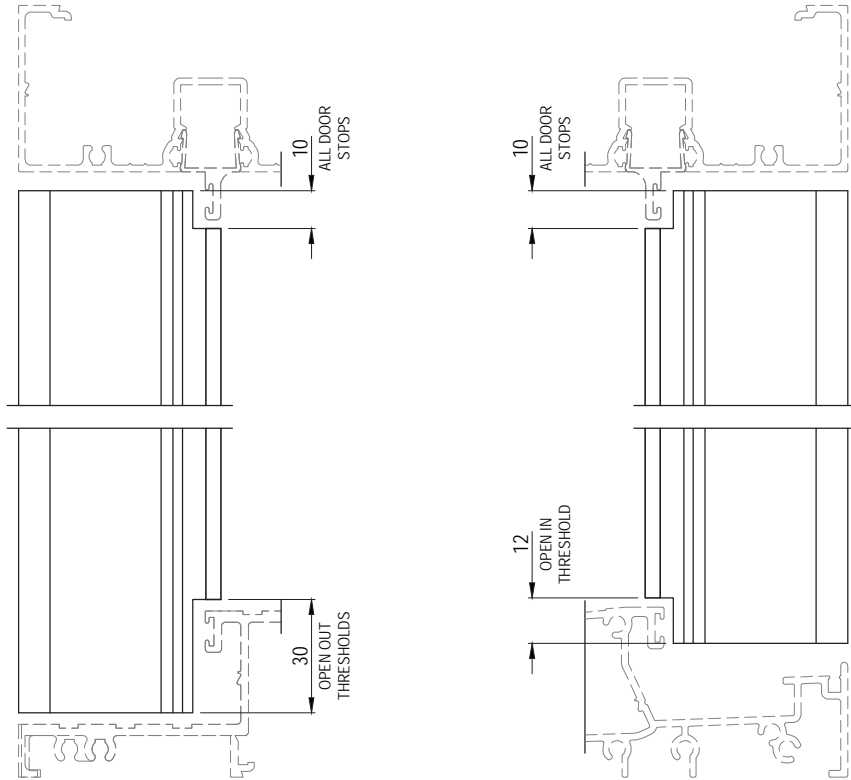

STD RAIL TIE ROD
ALL STILES

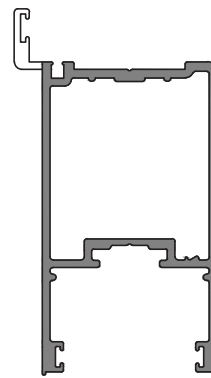

STD RAIL TIE ROD
ALL STILES

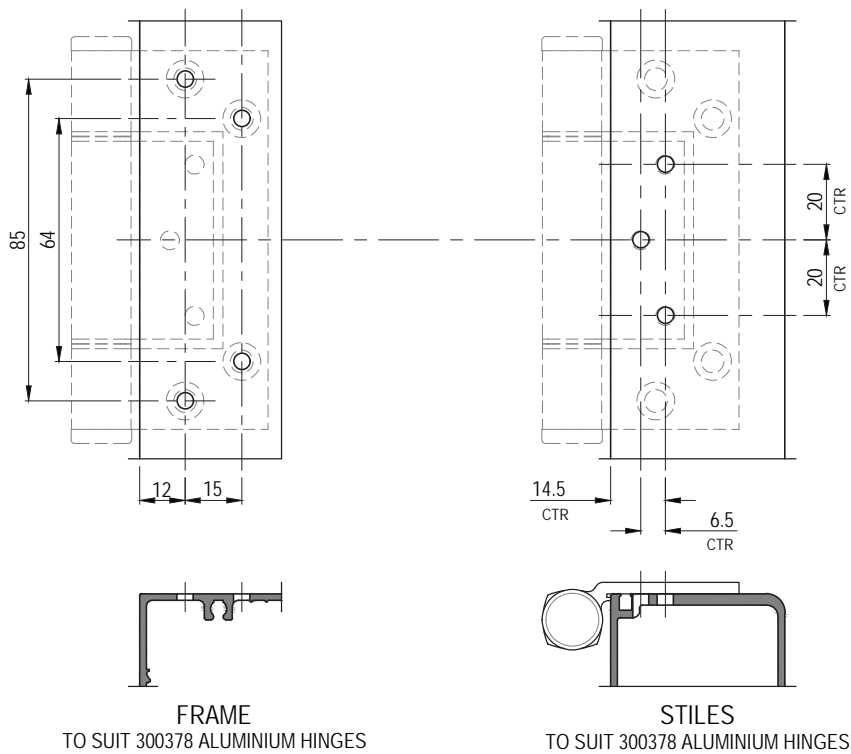
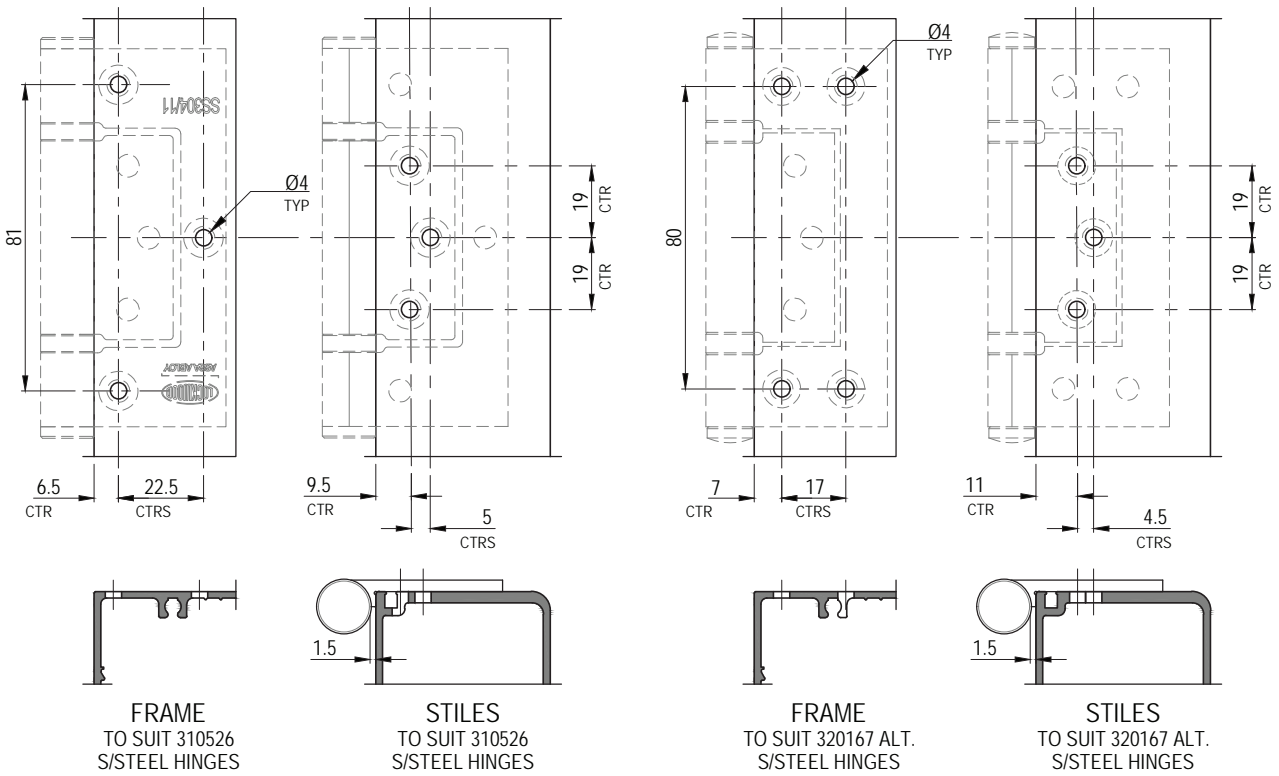

Please read in conjunction with Important Conditions – Index (also available on Capral website)

Machining - 317662 & 311259 Hinges

Scale 1:2

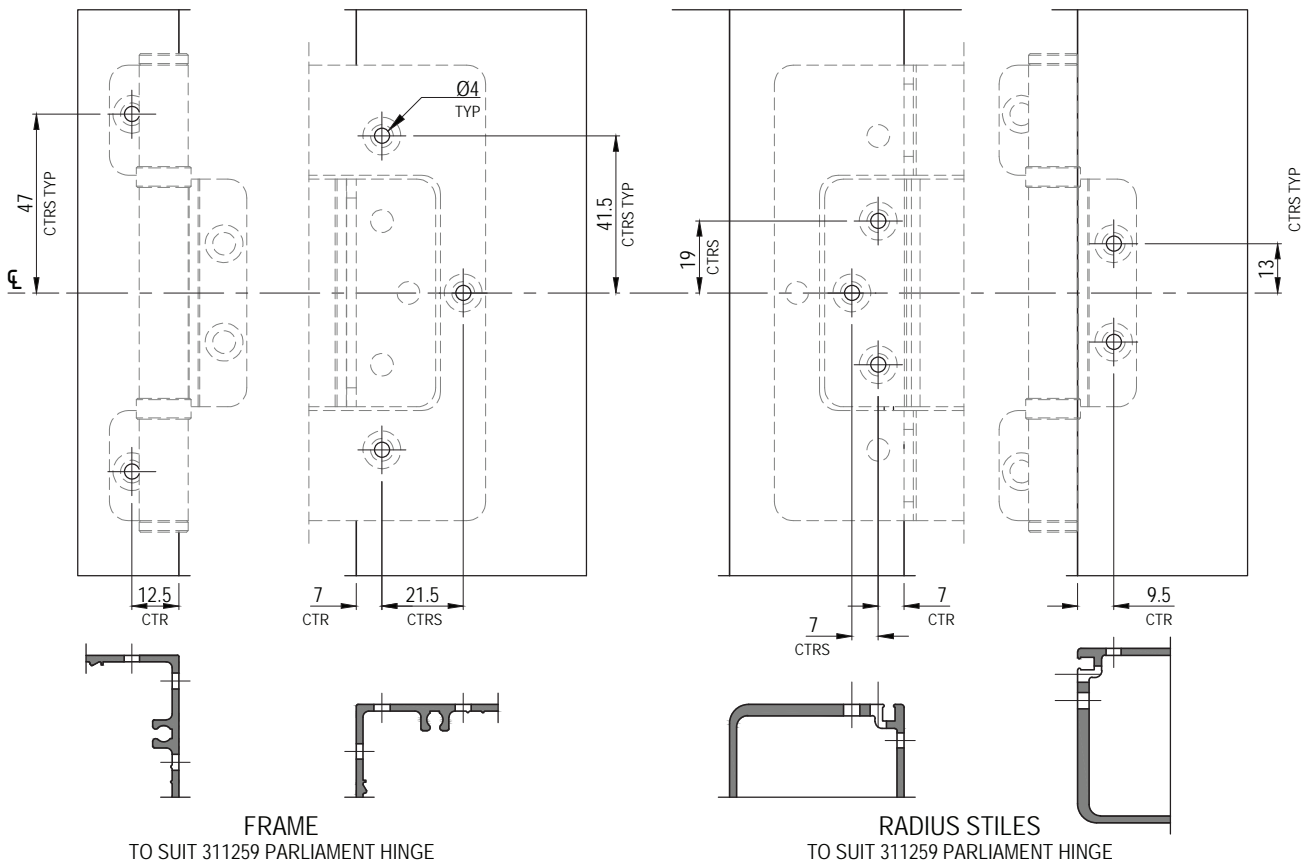
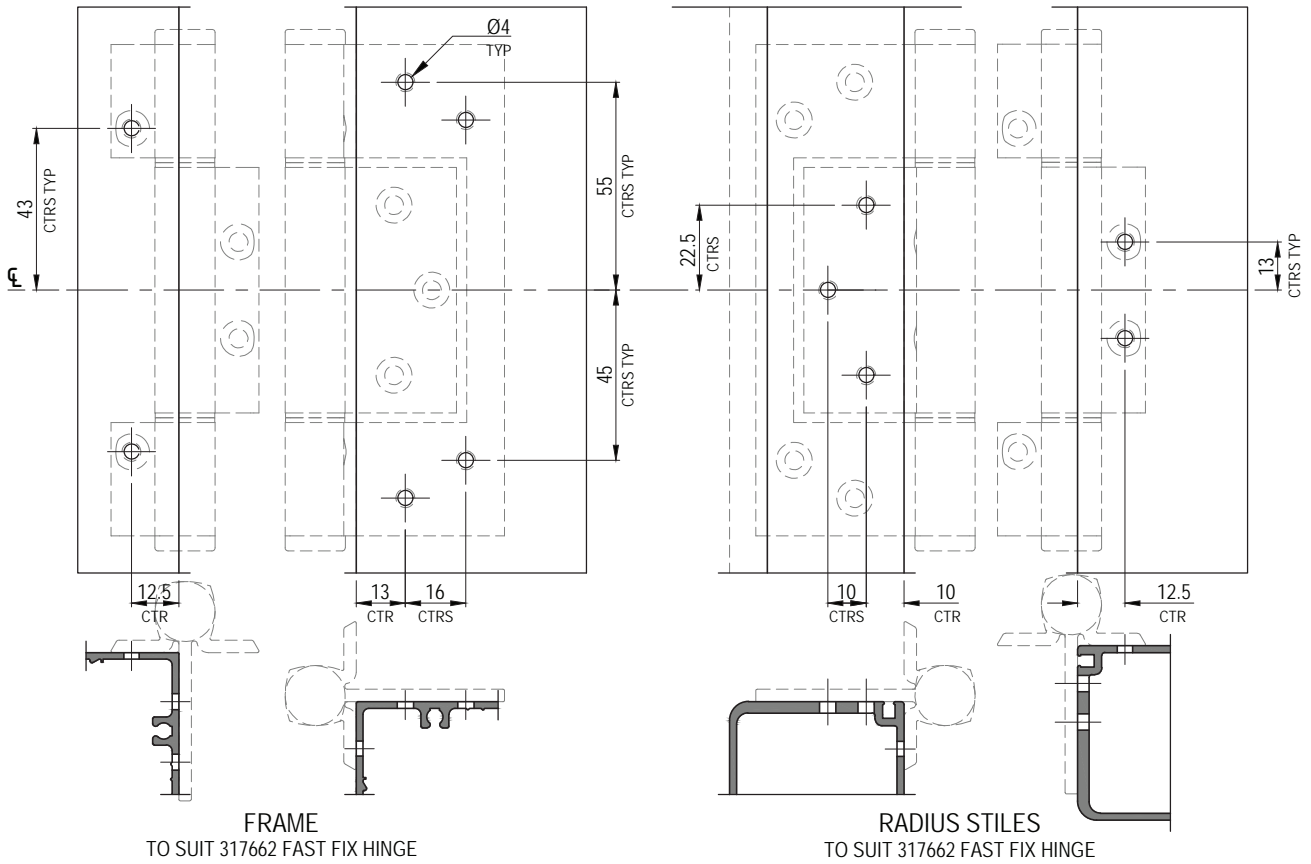

Please read in conjunction with Important Conditions – Index (also available on Capral website)

Machining - 317231 Adjustable Hinge

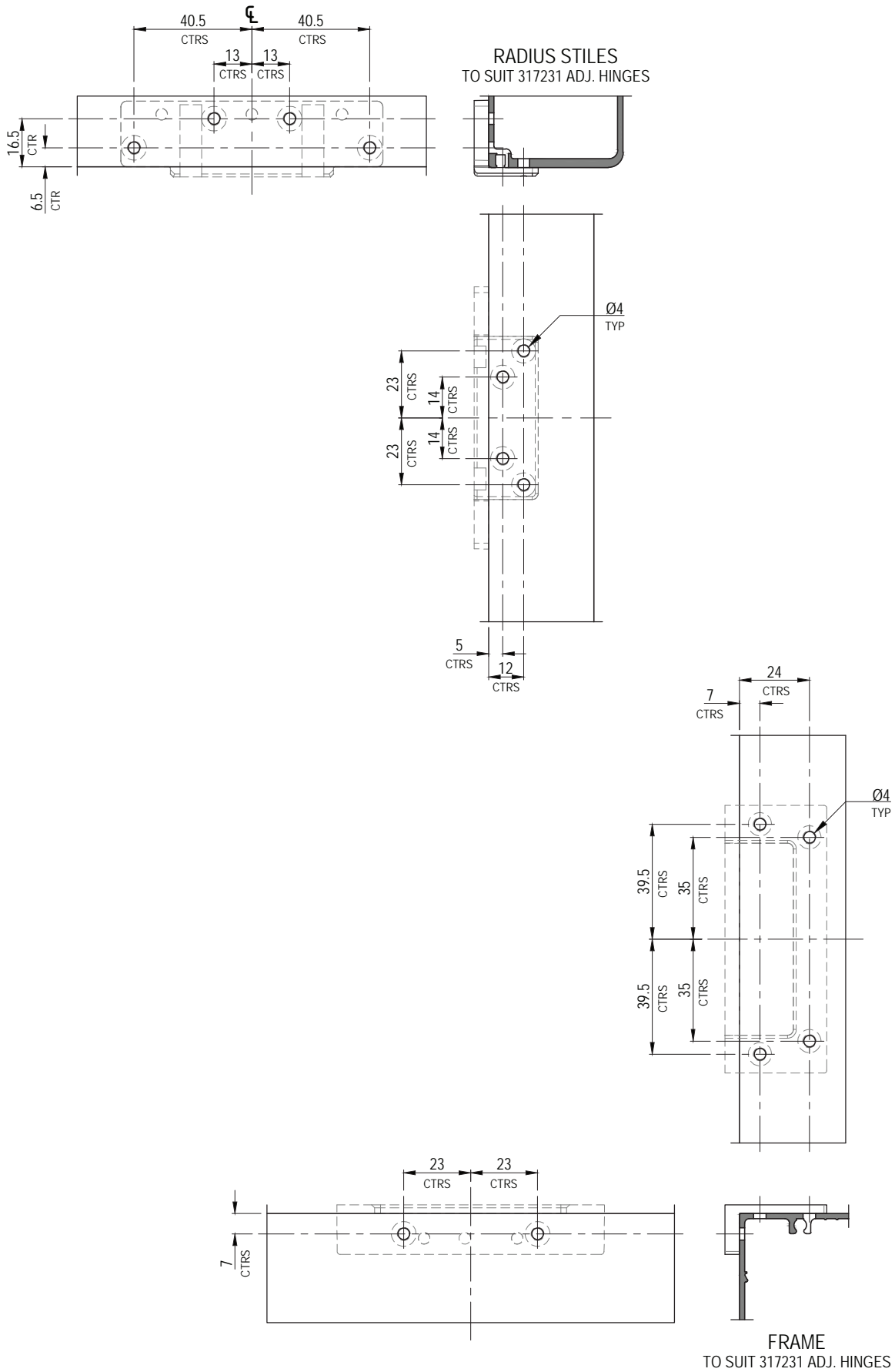

Please read in conjunction with Important Conditions – Index (also available on Capral website)

Machining - Jamb for COC Transoms

Scale 1:2

NOTE: MACHINE HOLES THAT SUIT CHOSEN FRAME.

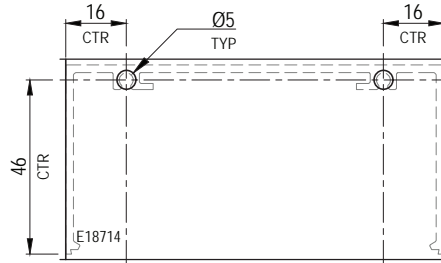

419 100mm FRAME

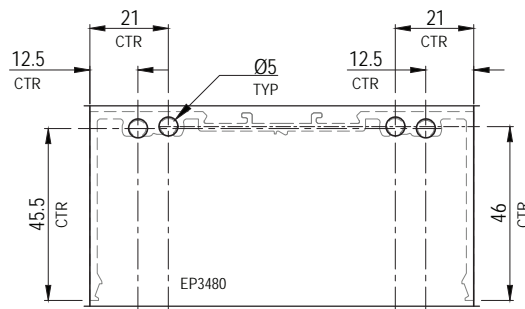

400 & 425 FRAMES

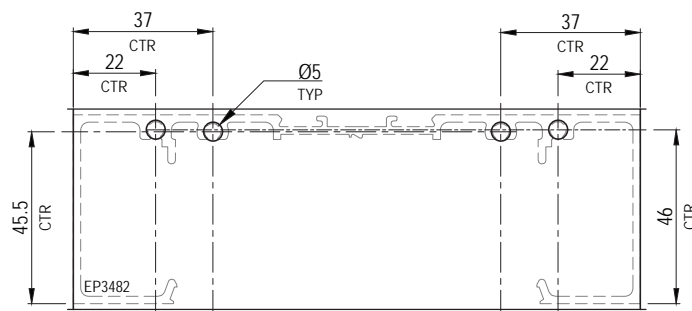

600, 601, 625 & 419 150mm FRAME

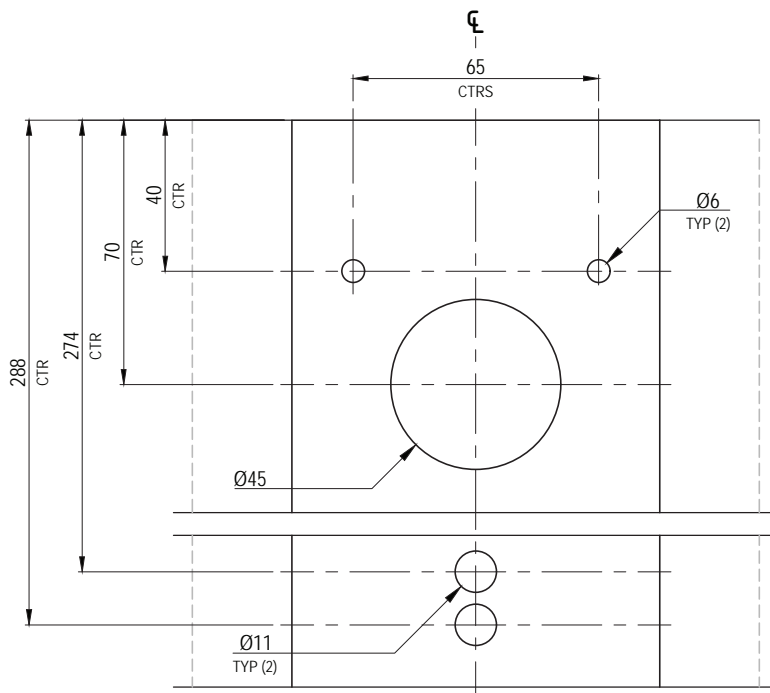
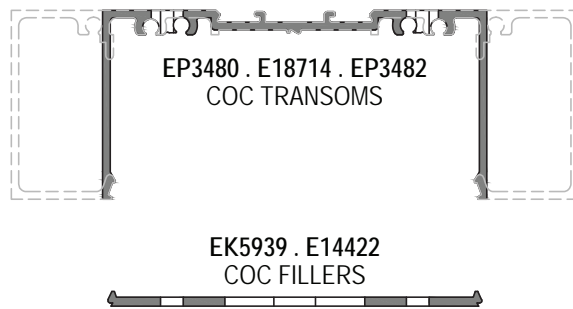
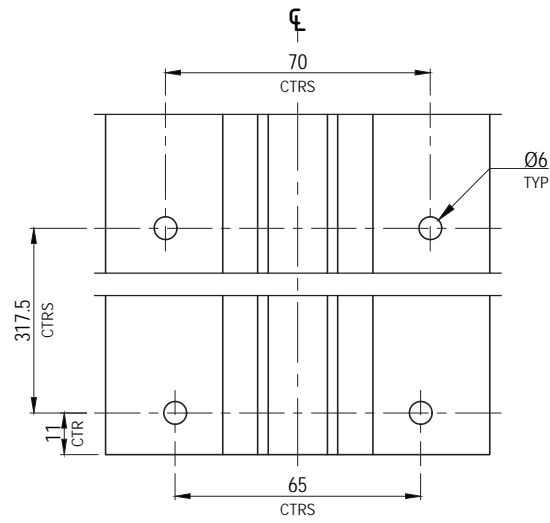

Please read in conjunction with Important Conditions – Index (also available on Capral website)

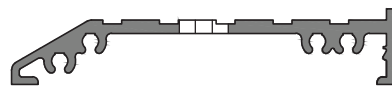
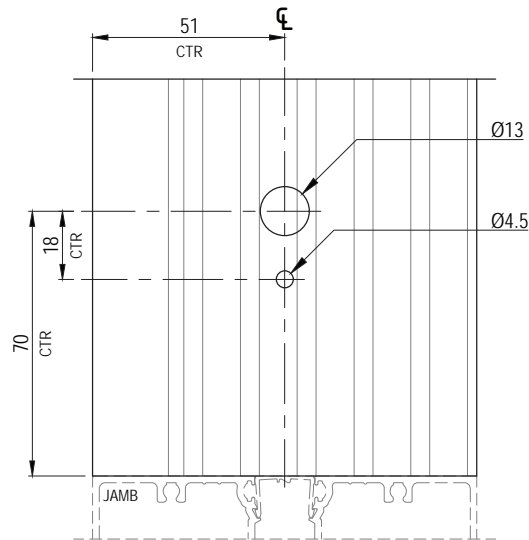

EP2365
101.6mm x 20mm FLAT THRESHOLD

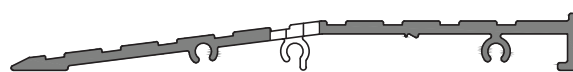
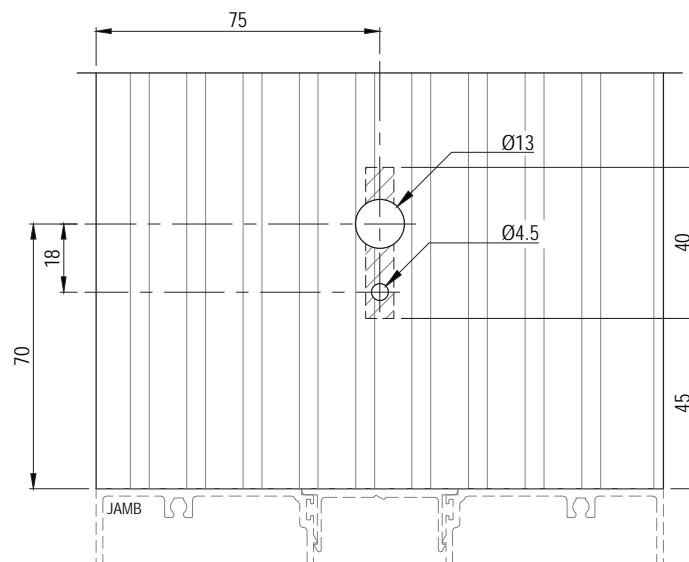

EP13540
150mm x 15mm RAMP THRESHOLD

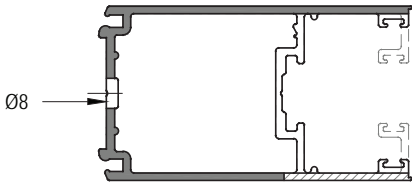

EP14647 . EP14893
SG . DG LOCK STILE
 AT TOP BOTH ASSEMBLY METHODS

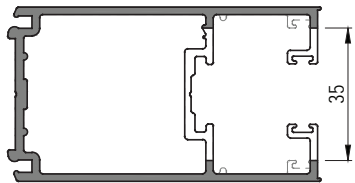
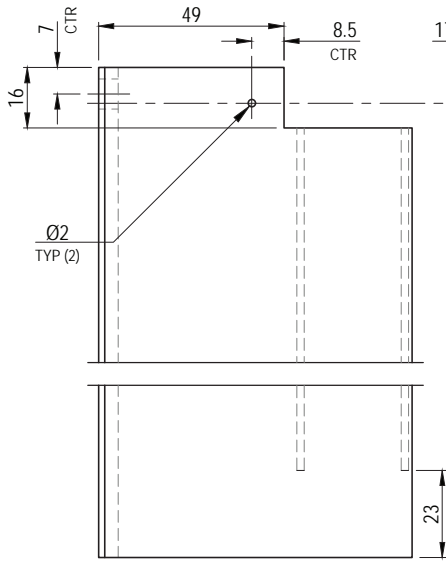

EP14647 . EP14893
SG . DG LOCK STILE
 AT BOTTOM BOTH ASSEMBLY METHODS

VARIOUS
SHALLOW & STD RAILS
 TOP RAIL
 BOTH ASSEMBLY METHODS

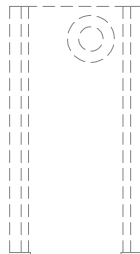
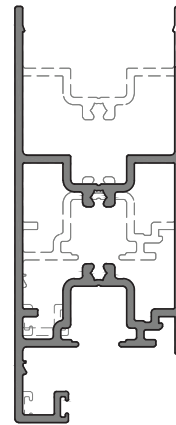

ARM CHANNEL
 PART OF 9800 CONCEALED
 OVERHEAD CLOSER
 BOTH ASSEMBLY METHODS

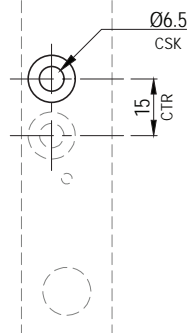

EP18288 . EP18287
SG . DG RAIL
 BOTTOM RAIL
 BOTH ASSEMBLY METHODS

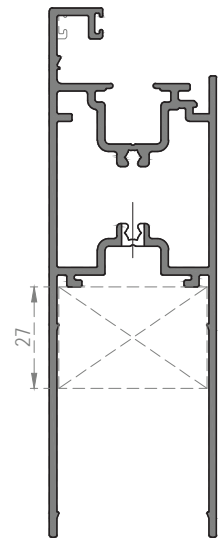
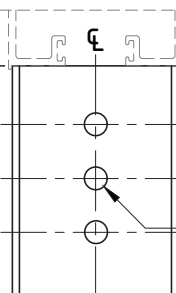

EP18354 . EP18353
EXTENDED RAILS
 BOTTOM RAIL
 BOTH ASSEMBLY METHODS

Please read in conjunction with Important Conditions – Index (also available on Capral website)

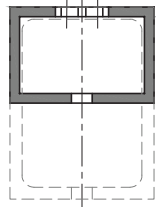
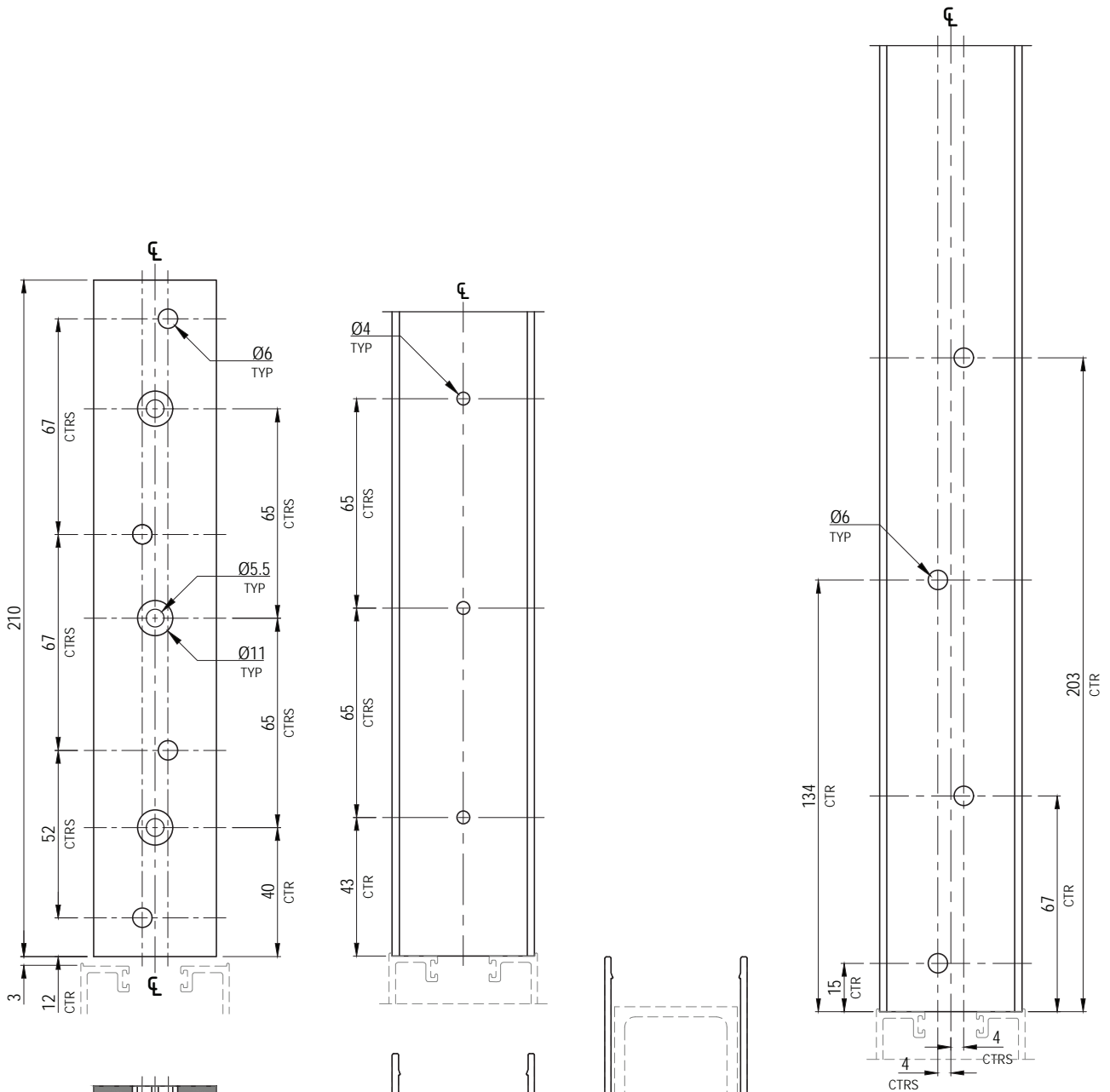

EG2205 . EE3956
 38.1 x 25.4 x 2.54 HOLLOW
 38.1 x 50.8 x 3.18 HOLLOW
 EURO BRACKET ASSEMBLY ONLY

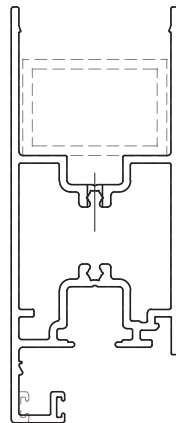

EP18288 . EP18287
 SG . DG RAIL
 TOP RAIL

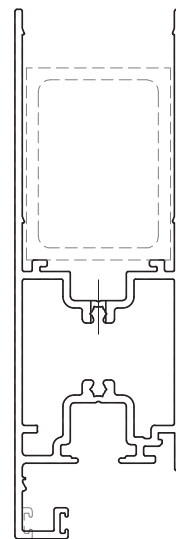

EP18354 . EP18353
 EXTENDED RAILS
 TOP RAIL

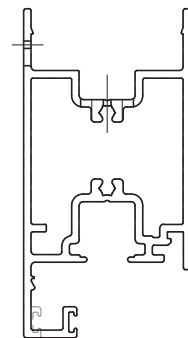

EP18289 . EP18286
 SG . DG SHALLOW RAIL
 TOP RAIL

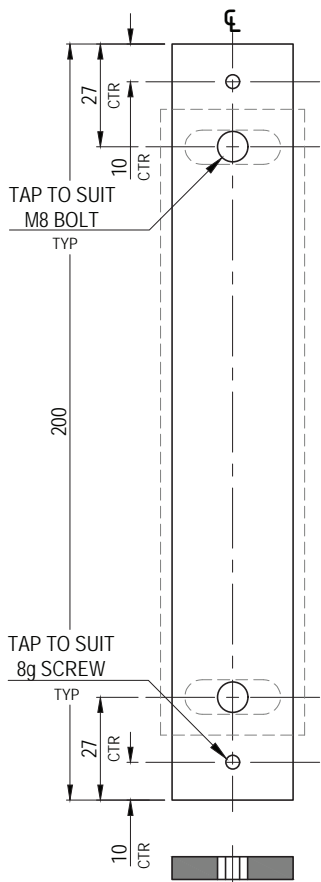

EX4022
FLAT BAR
TO SUIT 1030 ROLLER

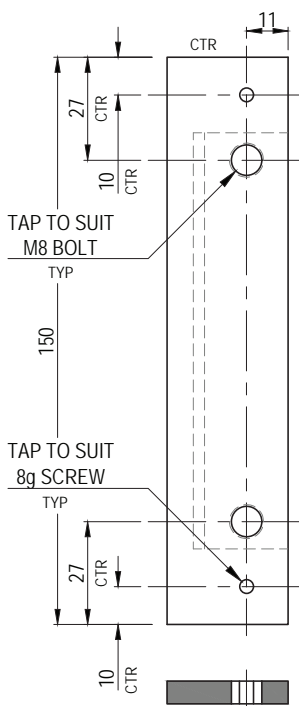

EX4022
FLAT BAR
TO SUIT 1031 ROLLER

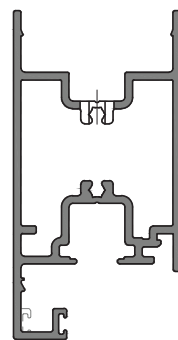
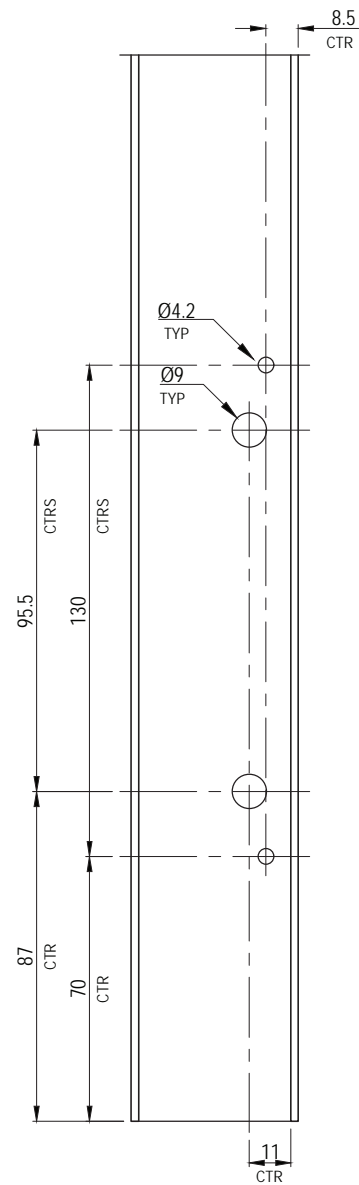
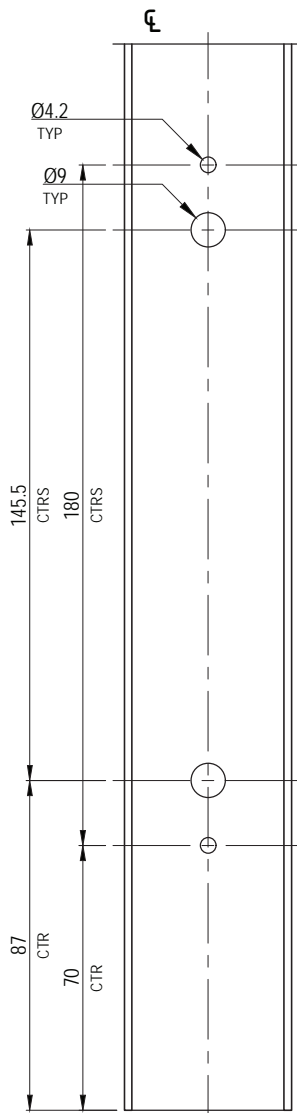

VARIOUS
SHALLOW RAILS
TO SUIT 1030 ROLLER

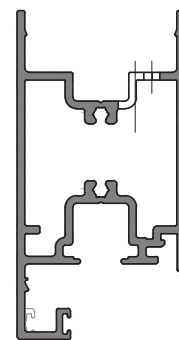

VARIOUS
SHALLOW RAILS
TO SUIT 1031 ROLLER

Machining - 1021 & 1022 Rollers & Guide Buttons

Scale 1:2

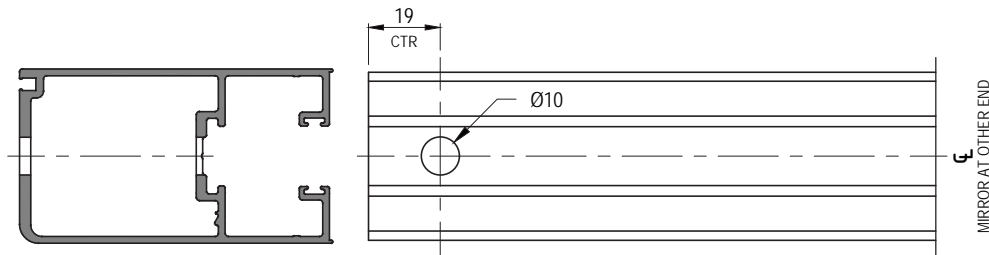

STILES
TO SUIT 1022 FLOOR ROLLER

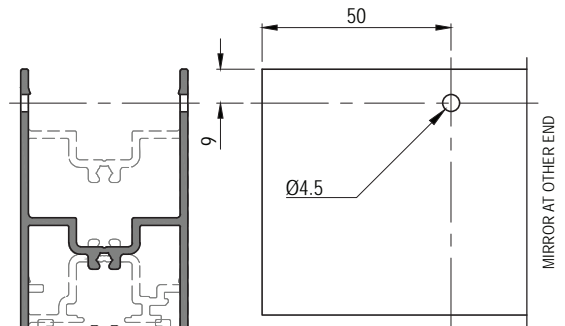
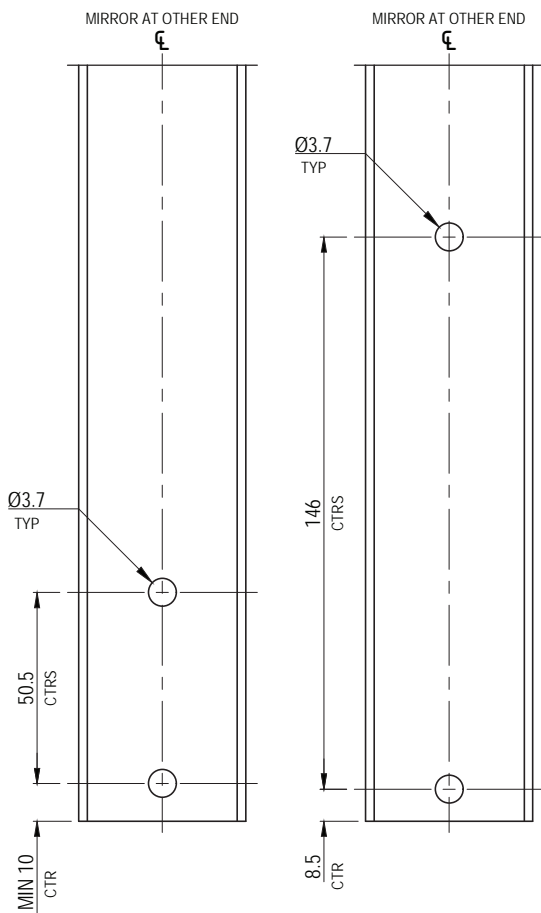

ALL RAILS
TOP RAIL TO SUIT GUIDE BUTTONS

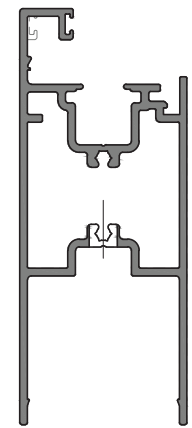

EP18288 . EP18287
SG . DG RAIL
BOTTOM RAIL TO SUIT
1021 FLOOR ROLLER

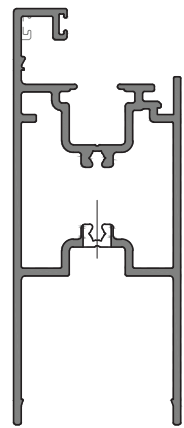

EP18288 . EP18287
SG . DG RAIL
BOTTOM RAIL TO SUIT
1022 FLOOR ROLLER

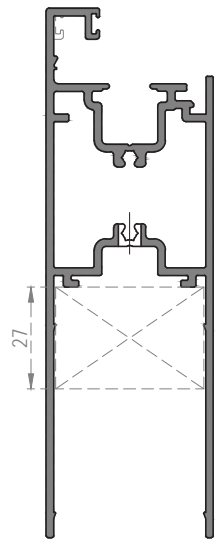

EP18354 . EP18353
EXTENDED RAILS
BOTTOM RAIL TO SUIT
1021 OR 1022 FLOOR ROLLER

Please read in conjunction with Important Conditions – Index (also available on Capral website)

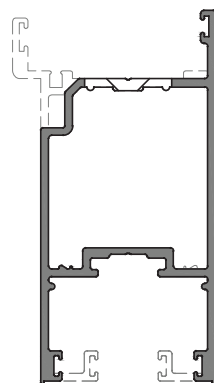
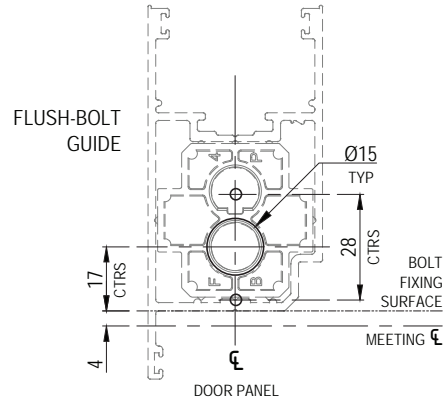
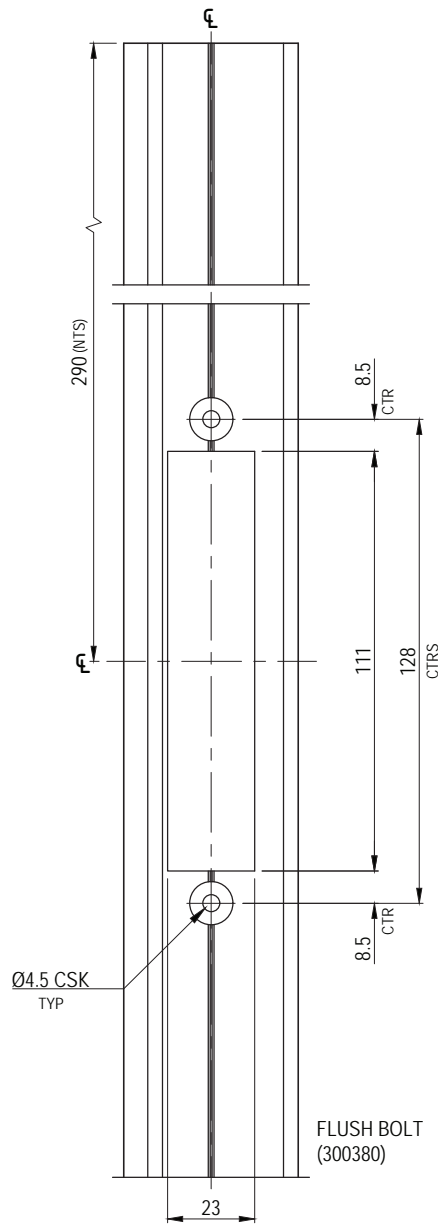

VARIOUS MEETING & COVER STILES

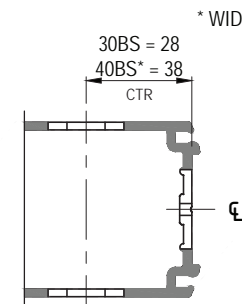
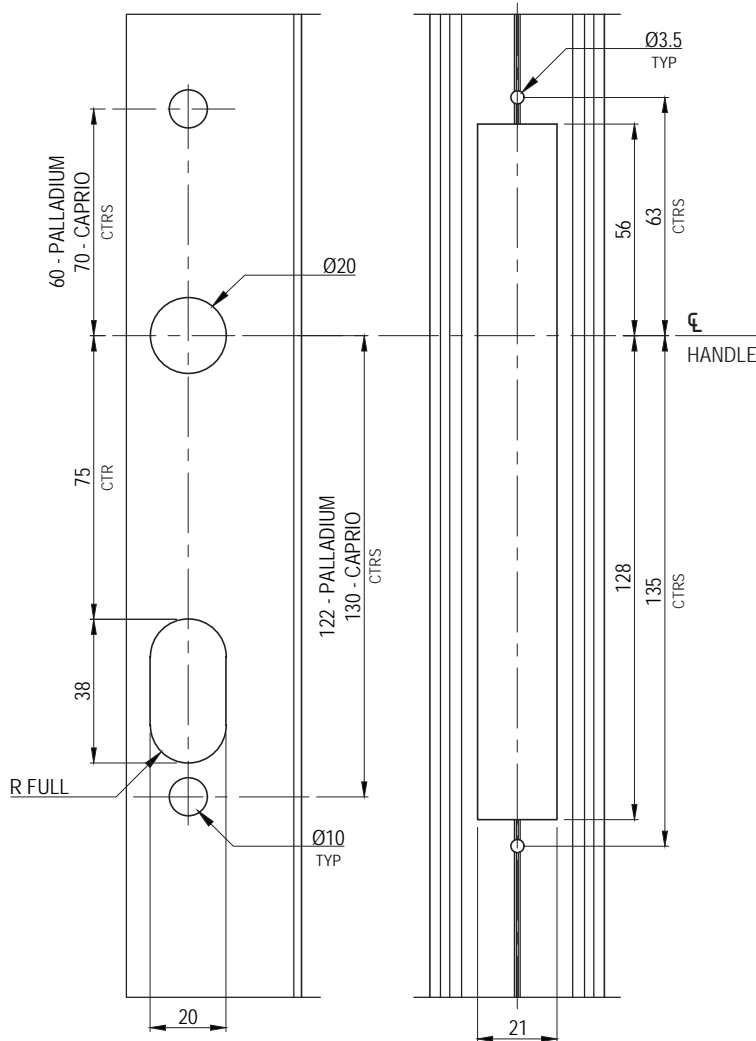

VARIOUS LOCK STILES
WIDE LOCK STILES

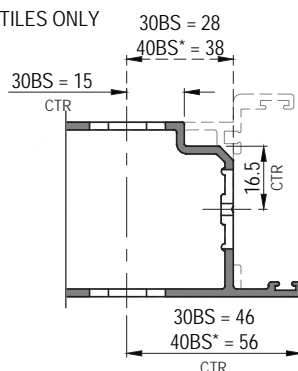

VARIOUS MEETING & COVER STILES
WIDE COVER STILES

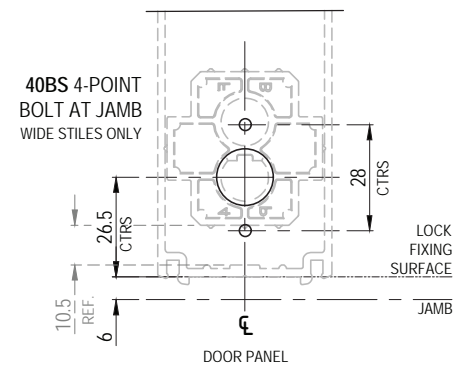
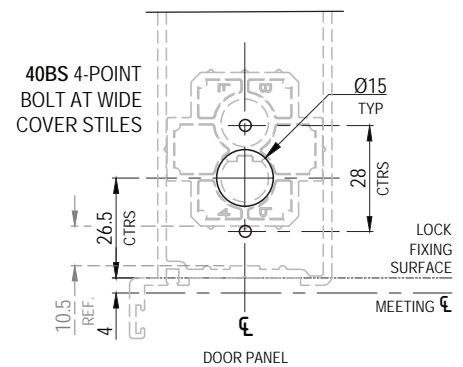
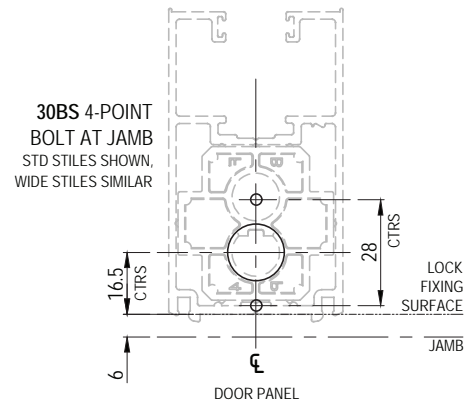
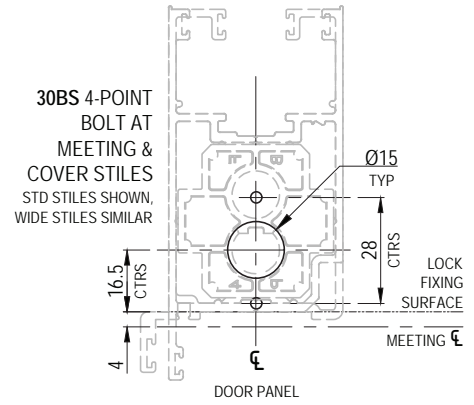

Please read in conjunction with Important Conditions – Index (also available on Capral website)

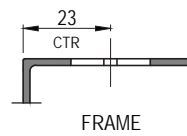
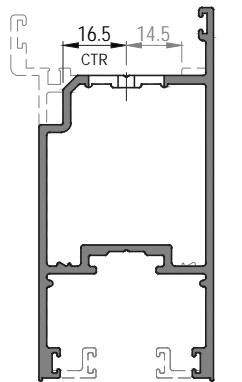
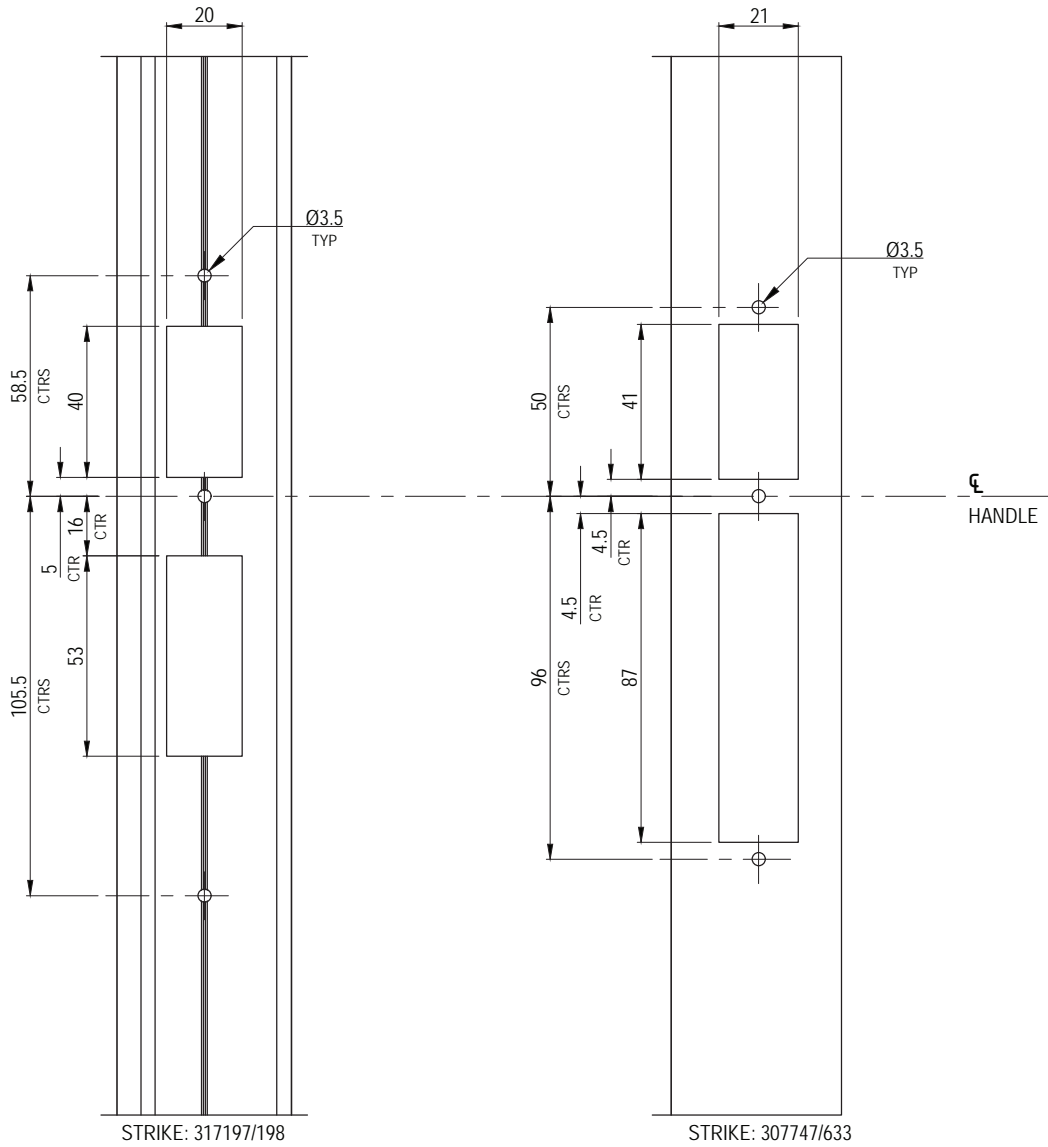

VARIOUS MEETING & COVER STILES

Please read in conjunction with Important Conditions – Index (also available on Capral website)

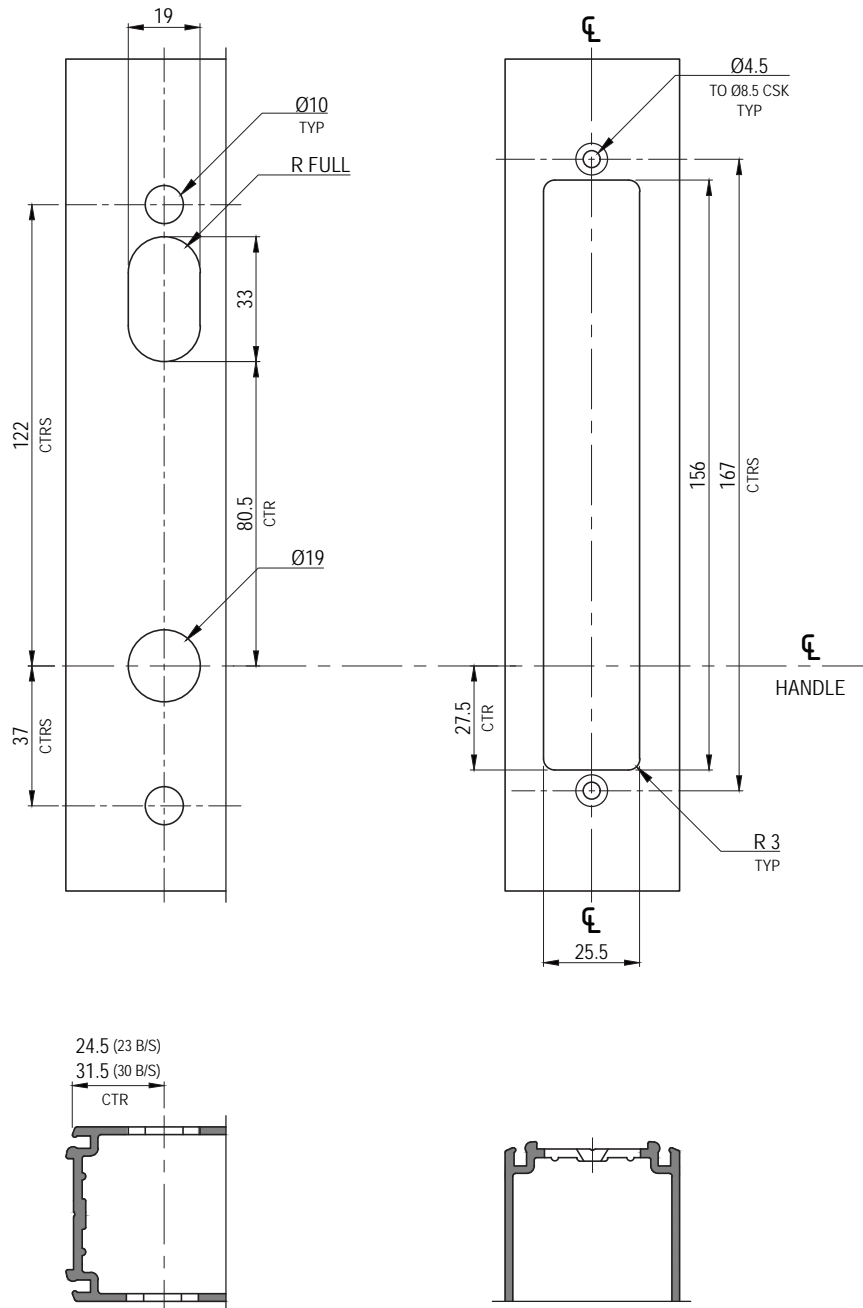

VARIOUS
LOCK STILES

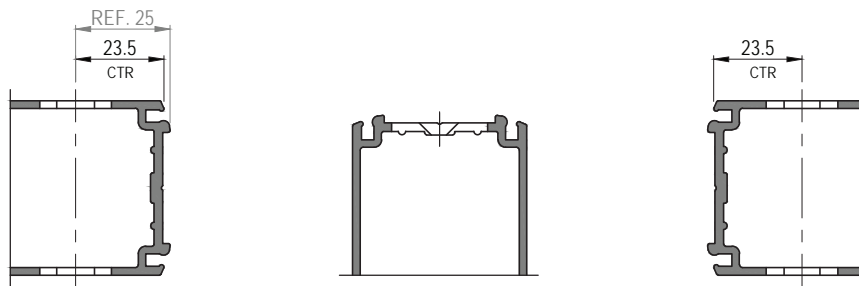
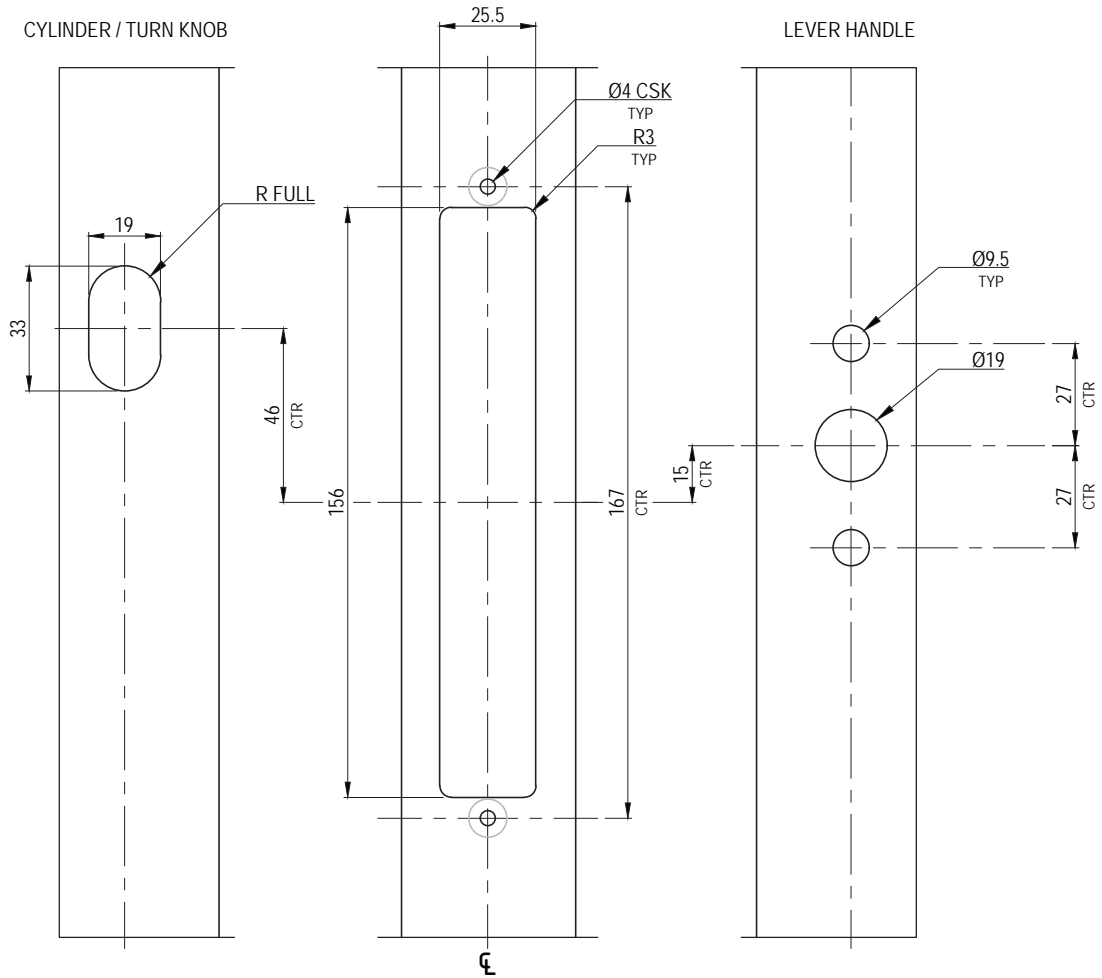

VARIOUS
LOCK STILES

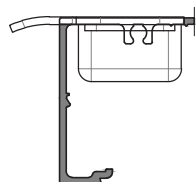
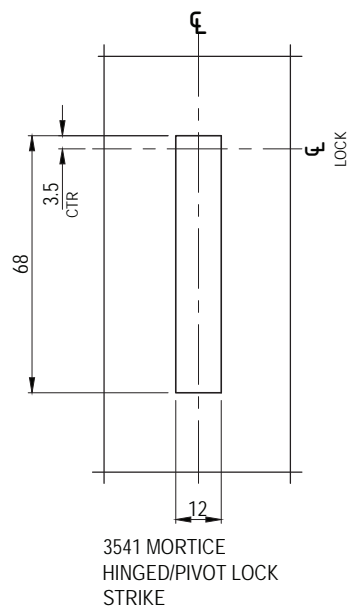
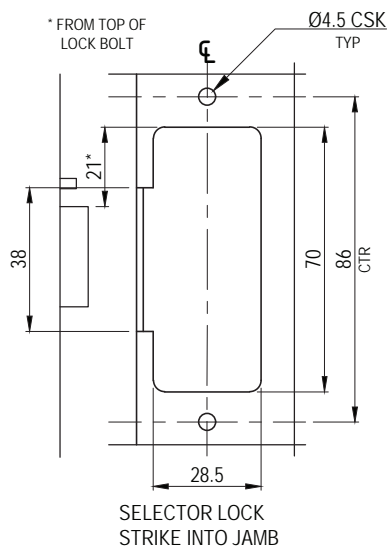
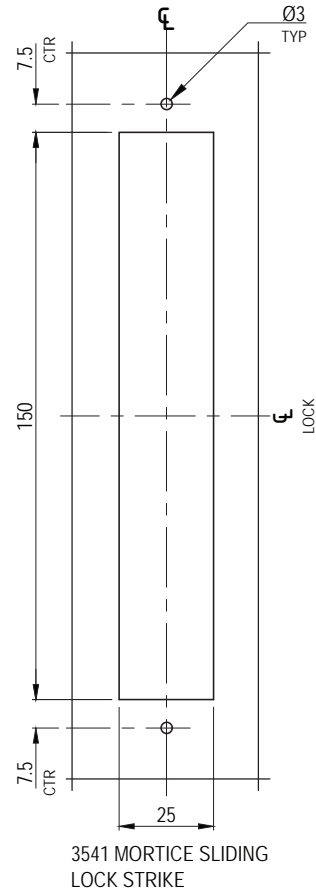
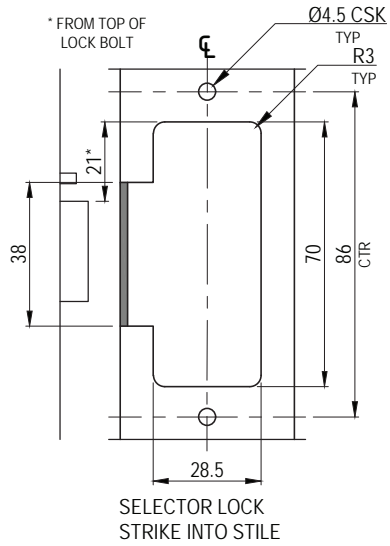

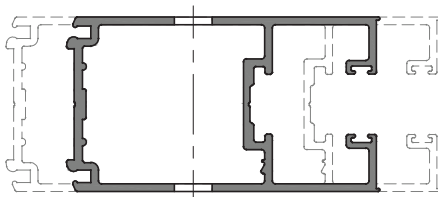
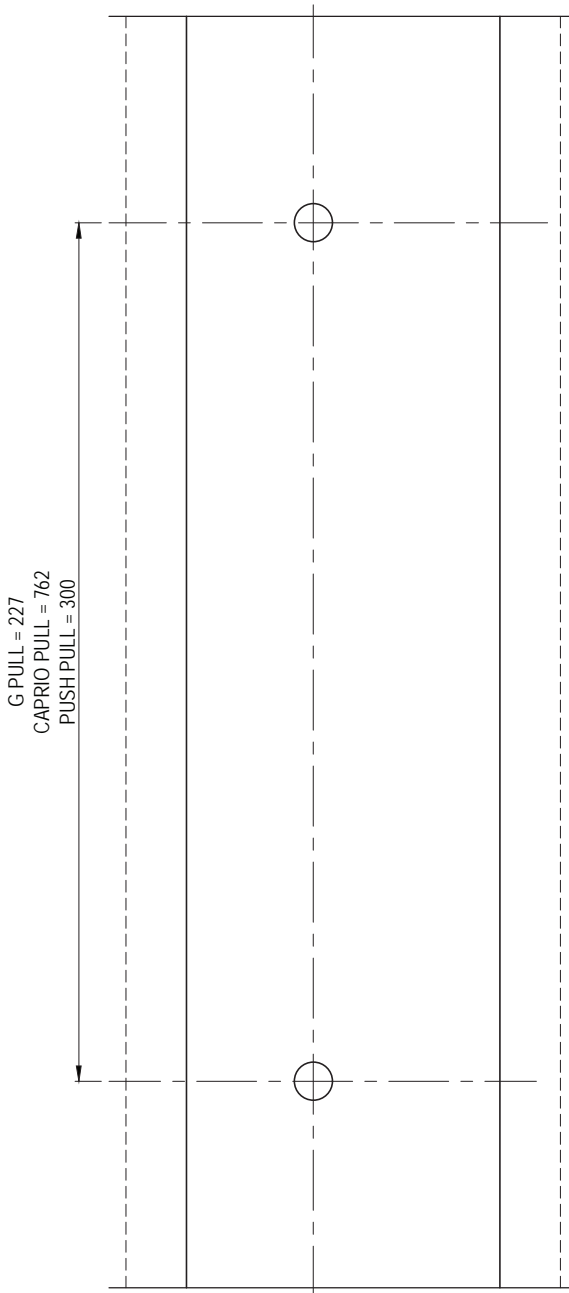

VARIOUS
ALL STILES

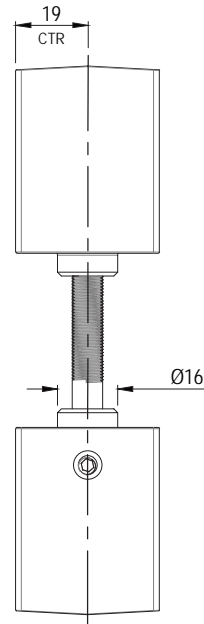

317693
CAPRIO 800mm
PULL HANDLE

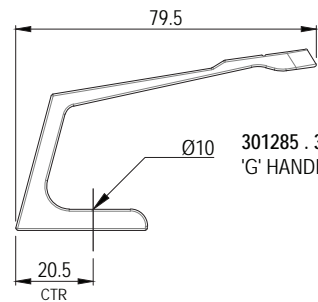

301285 . 301286
'G' HANDLE PULL

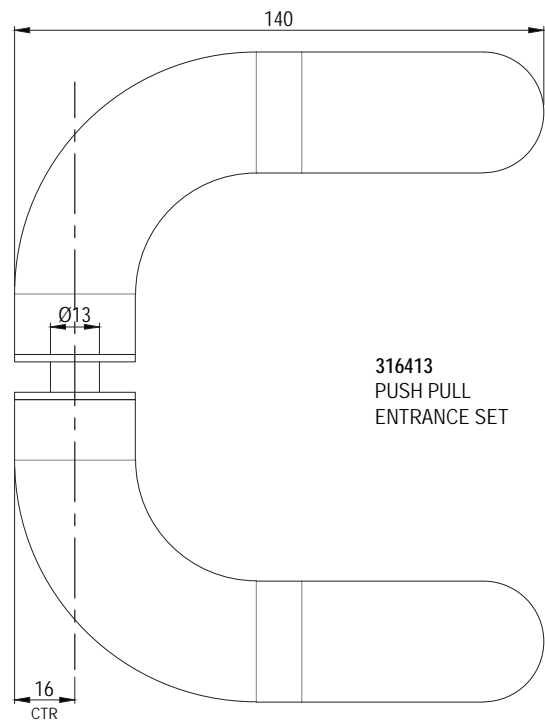

316413
PUSH PULL
ENTRANCE SET

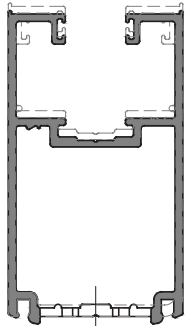

**VARIOUS
STILES**

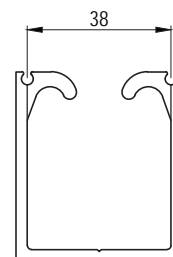
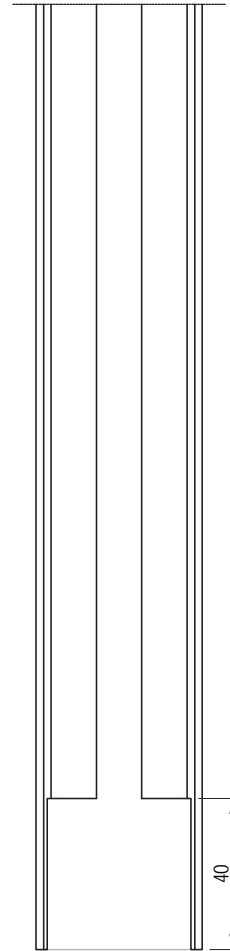
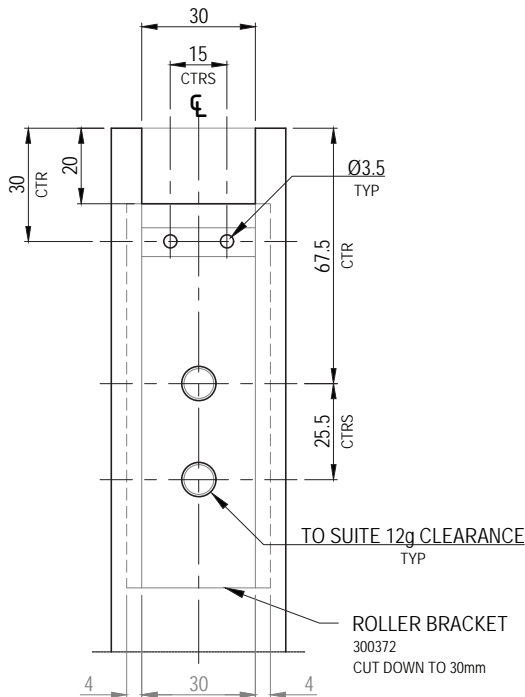

**EN8012
1061 ROLLER HEAD
NON LOCKING END**

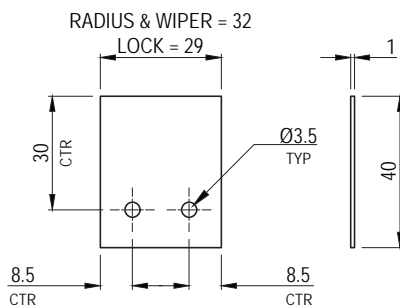

**BY OTHERS
STILE COVER PLATE**

Please read in conjunction with Important Conditions – Index (also available on Capral website)

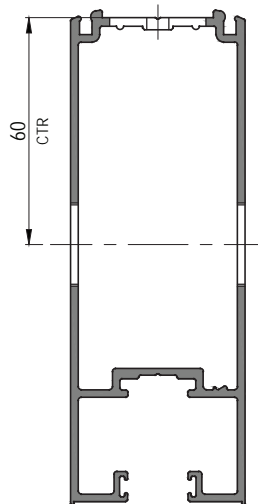
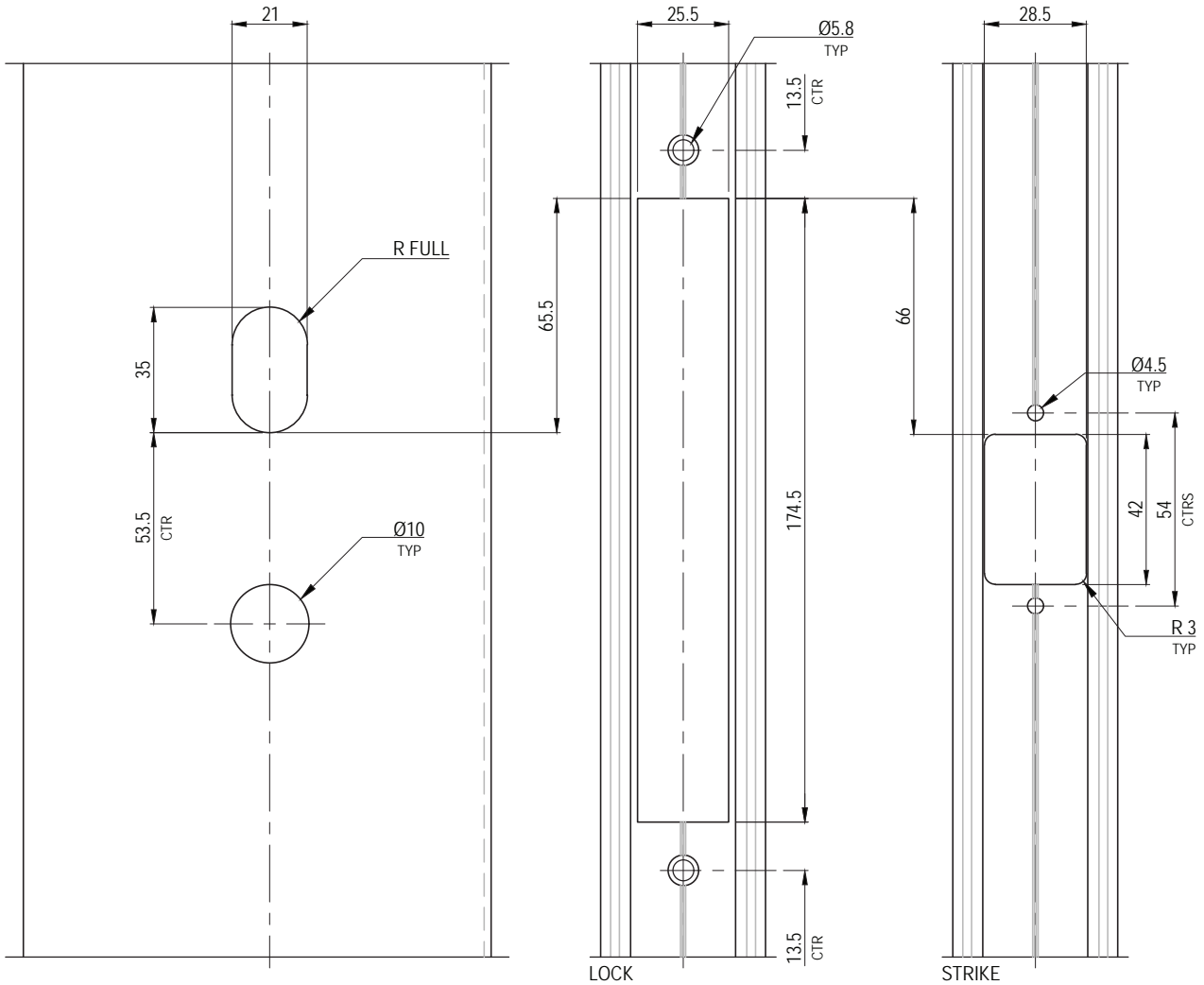

VARIOUS
WIDE STILES

Please read in conjunction with Important Conditions - Index (also available on Capral website)

Machining - LCL Lock

Scale 1:2

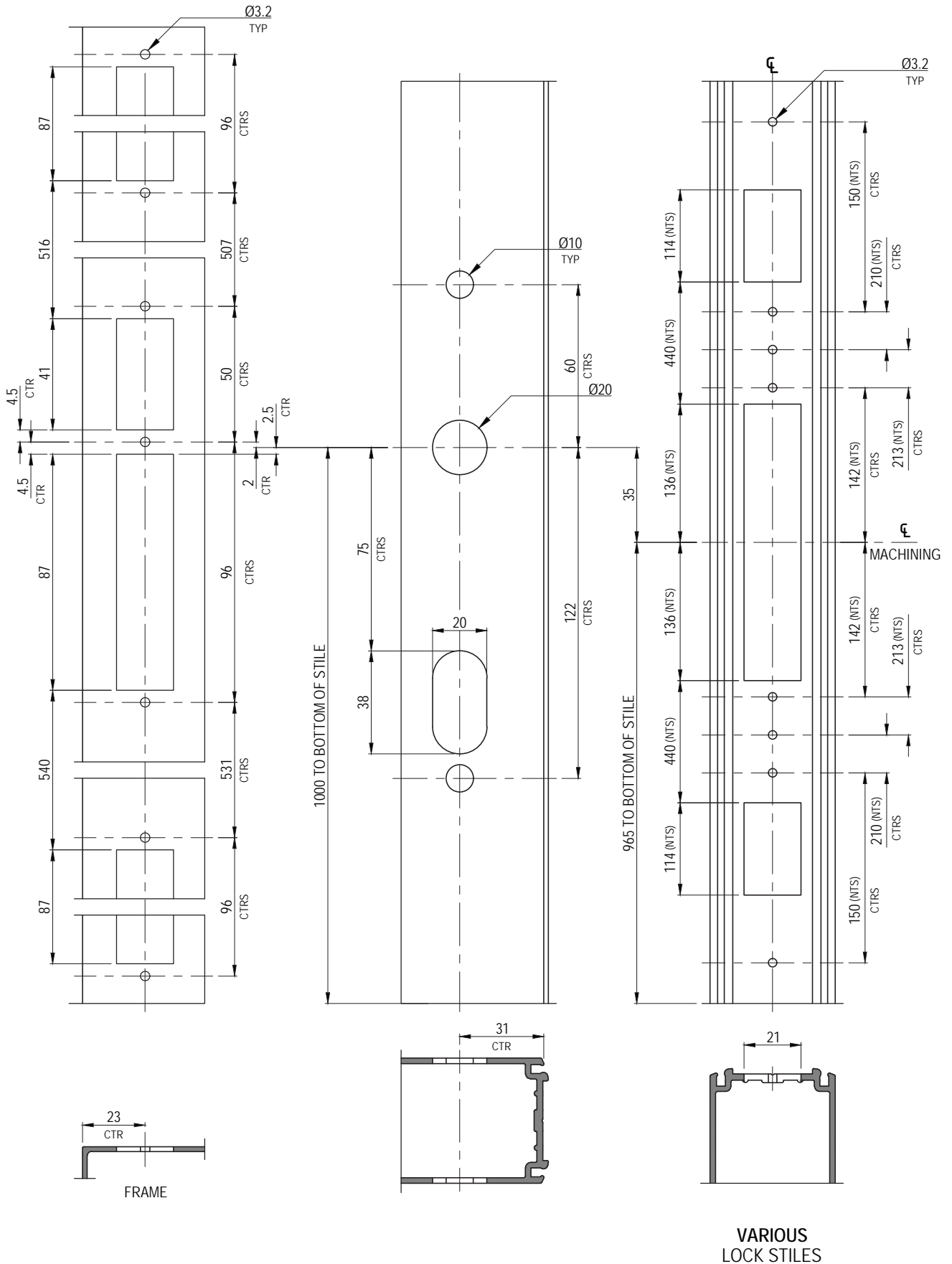

Please read in conjunction with Important Conditions - Index (also available on Capral website)

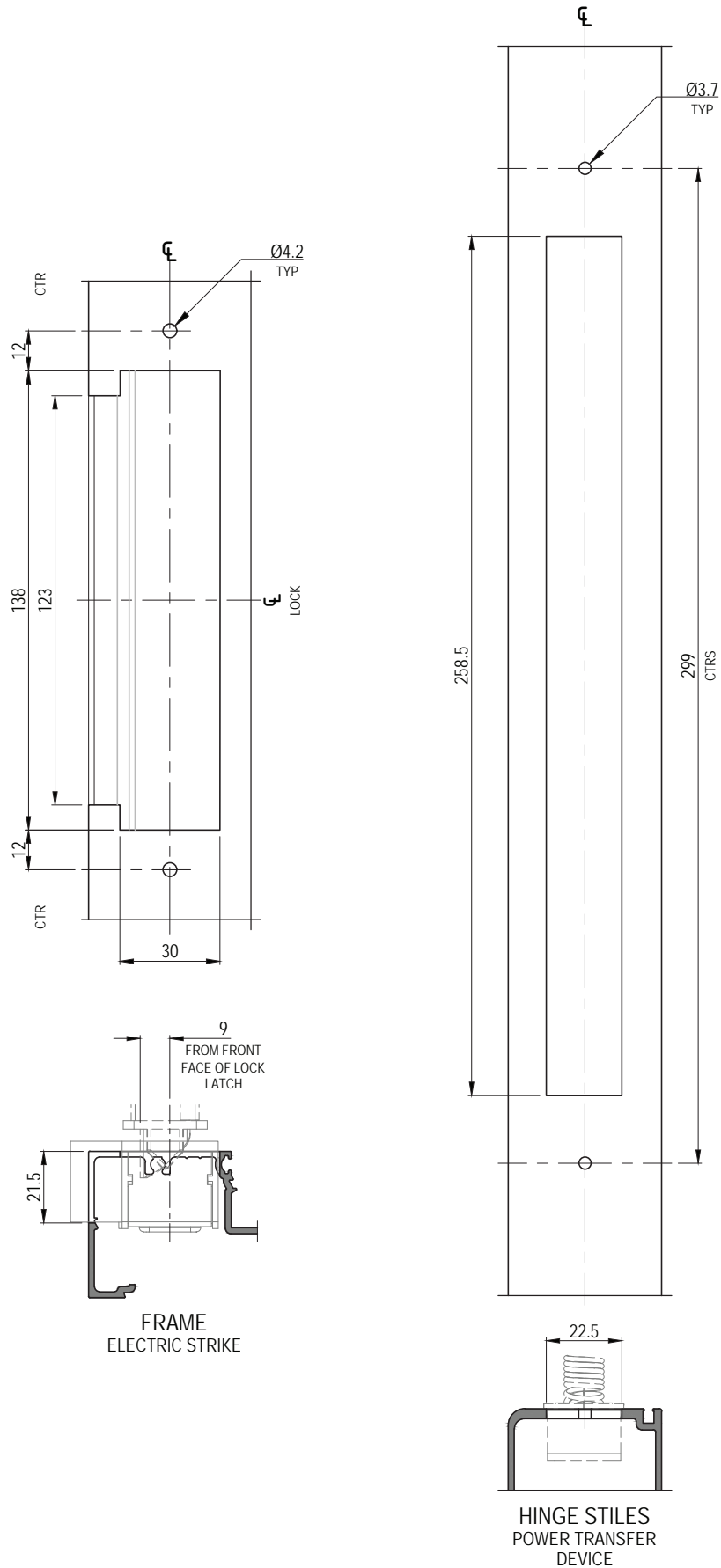

Please read in conjunction with Important Conditions – Index (also available on Capral website)

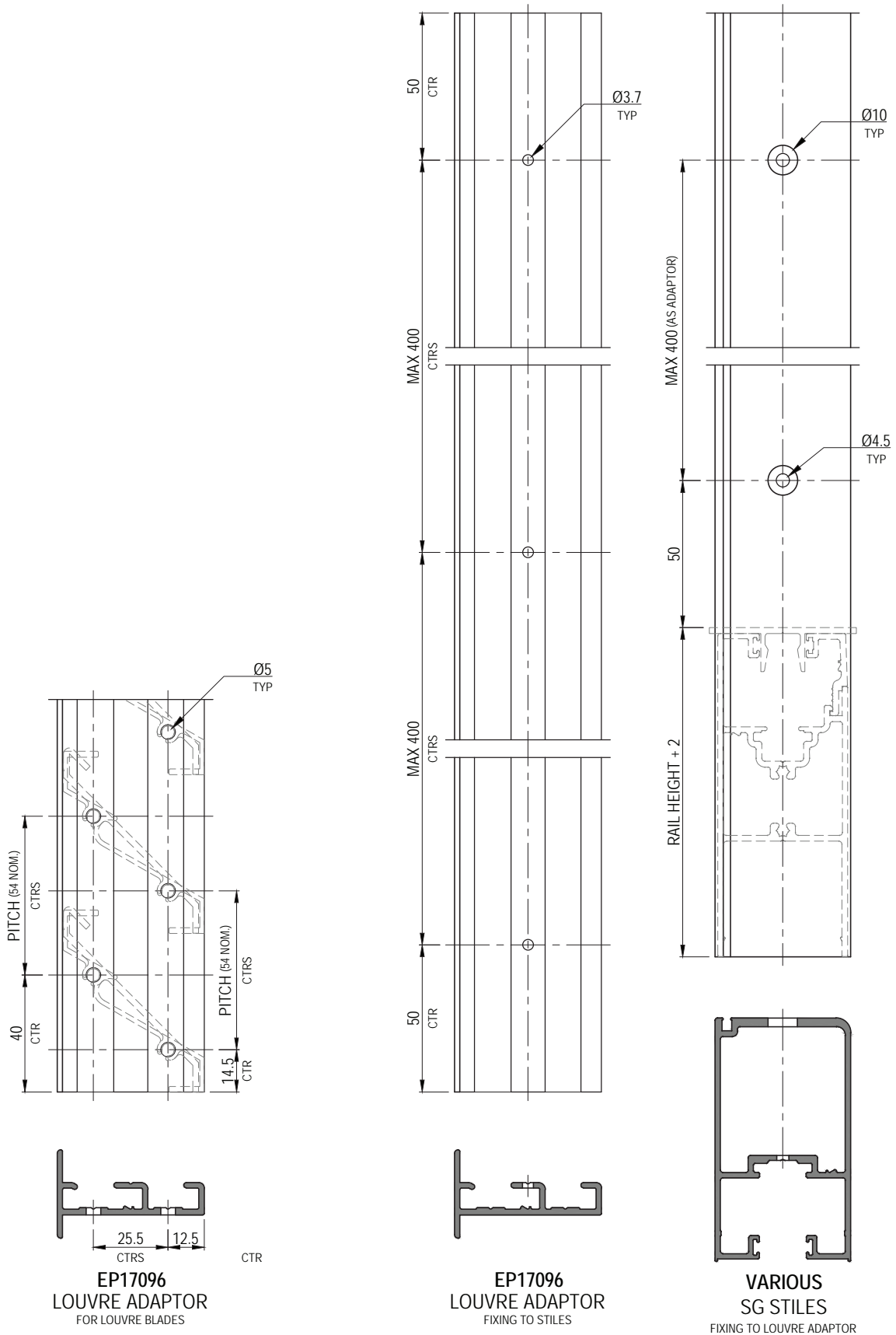

Please read in conjunction with Important Conditions – Index (also available on Capral website)

VARIOUS
ALL HINGE STILES

EP18288 . EP18287
SG . DG RAIL & HEAD

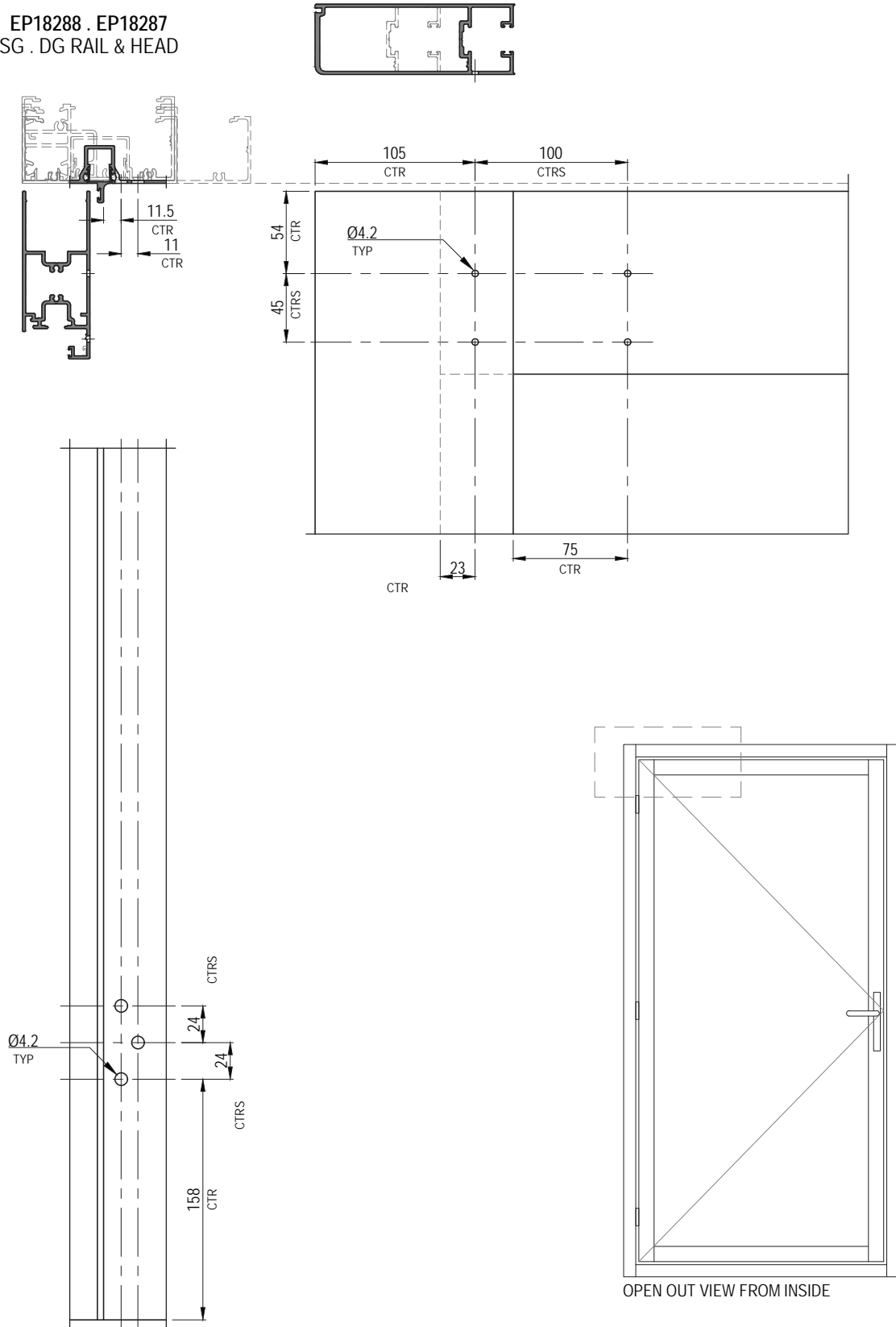

Please read in conjunction with Important Conditions – Index (also available on Capral website)

Machining - Open Out 7714 Arm Closer

Scale 1:2

VARIOUS
ALL HINGE STILES

EP18288 . EP18287
SG . DG RAIL & HEAD

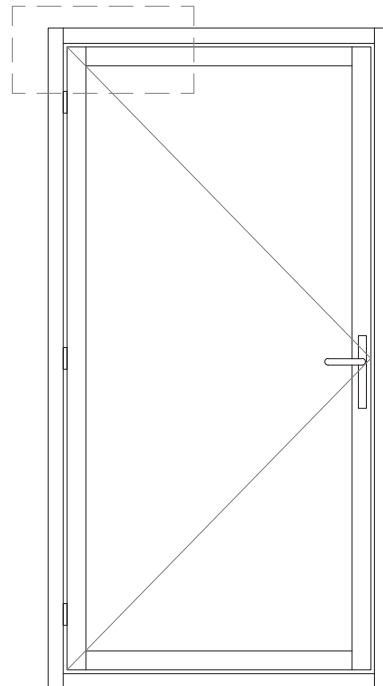
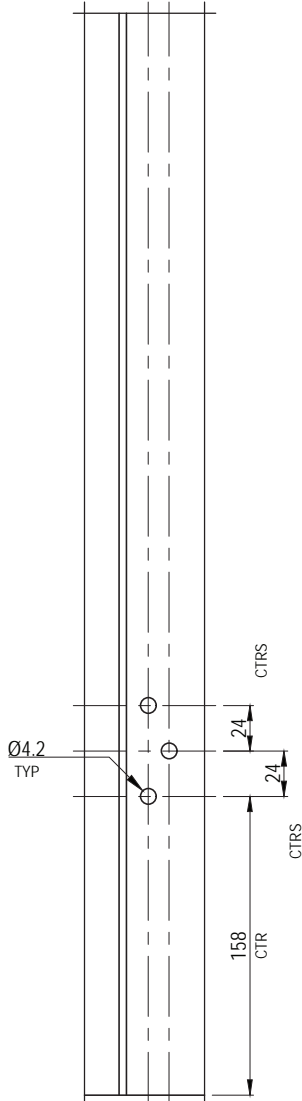
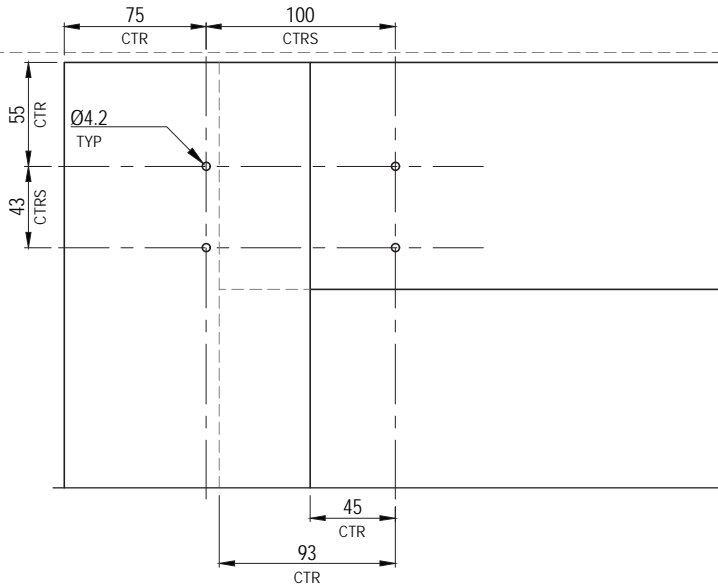
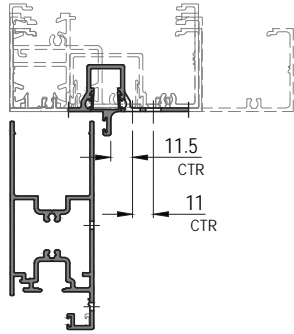
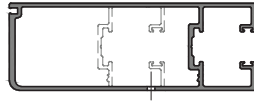

OPEN OUT VIEW FROM INSIDE

Please read in conjunction with Important Conditions – Index (also available on Capral website)

VARIOUS
ALL HINGE STILES

EP18288 . EP18287
SG . DG RAIL & HEAD

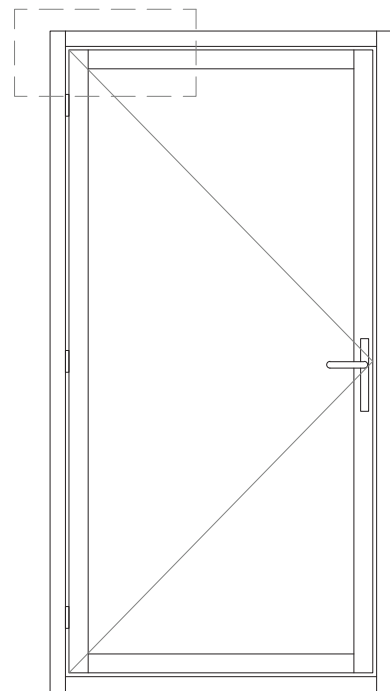
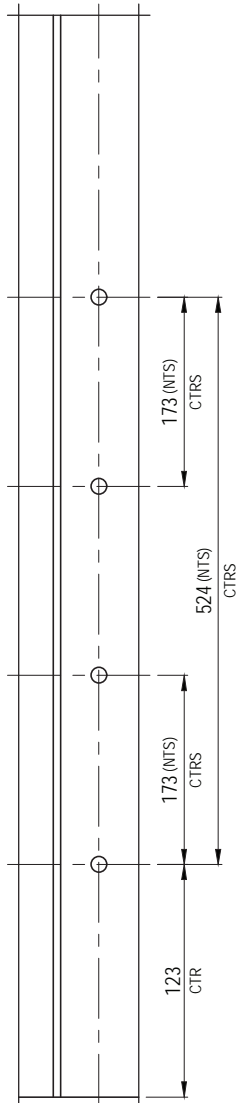
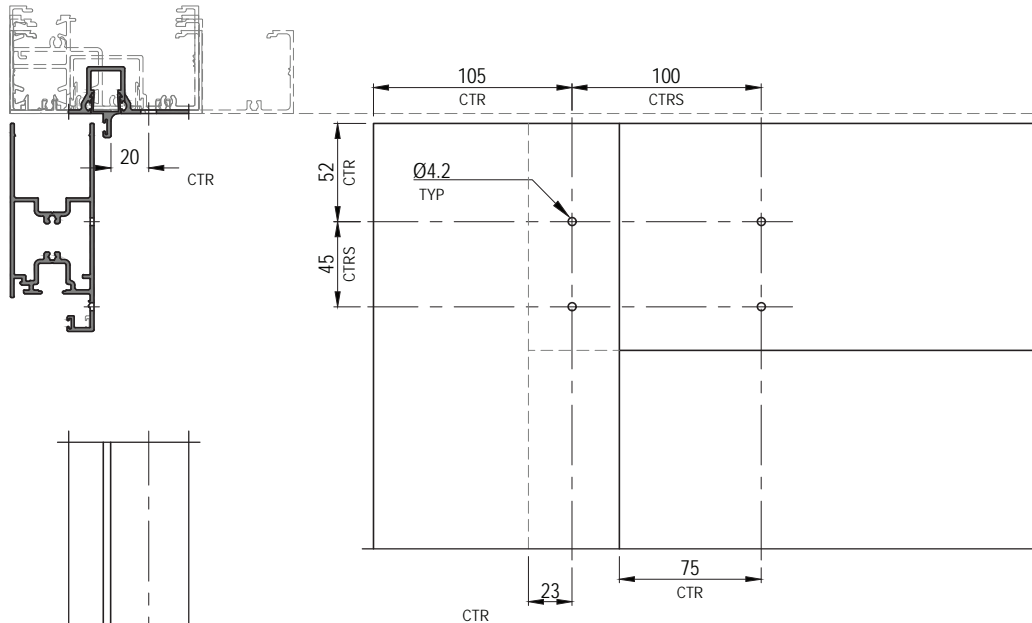
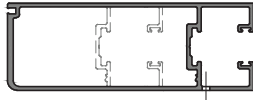

OPEN OUT VIEW FROM INSIDE

Please read in conjunction with Important Conditions – Index (also available on Capral website)

Machining - Open Out 7714 Slide Track Closer

Scale 1:2

VARIOUS
ALL HINGE STILES

EP18288 . EP18287
SG . DG RAIL & HEAD

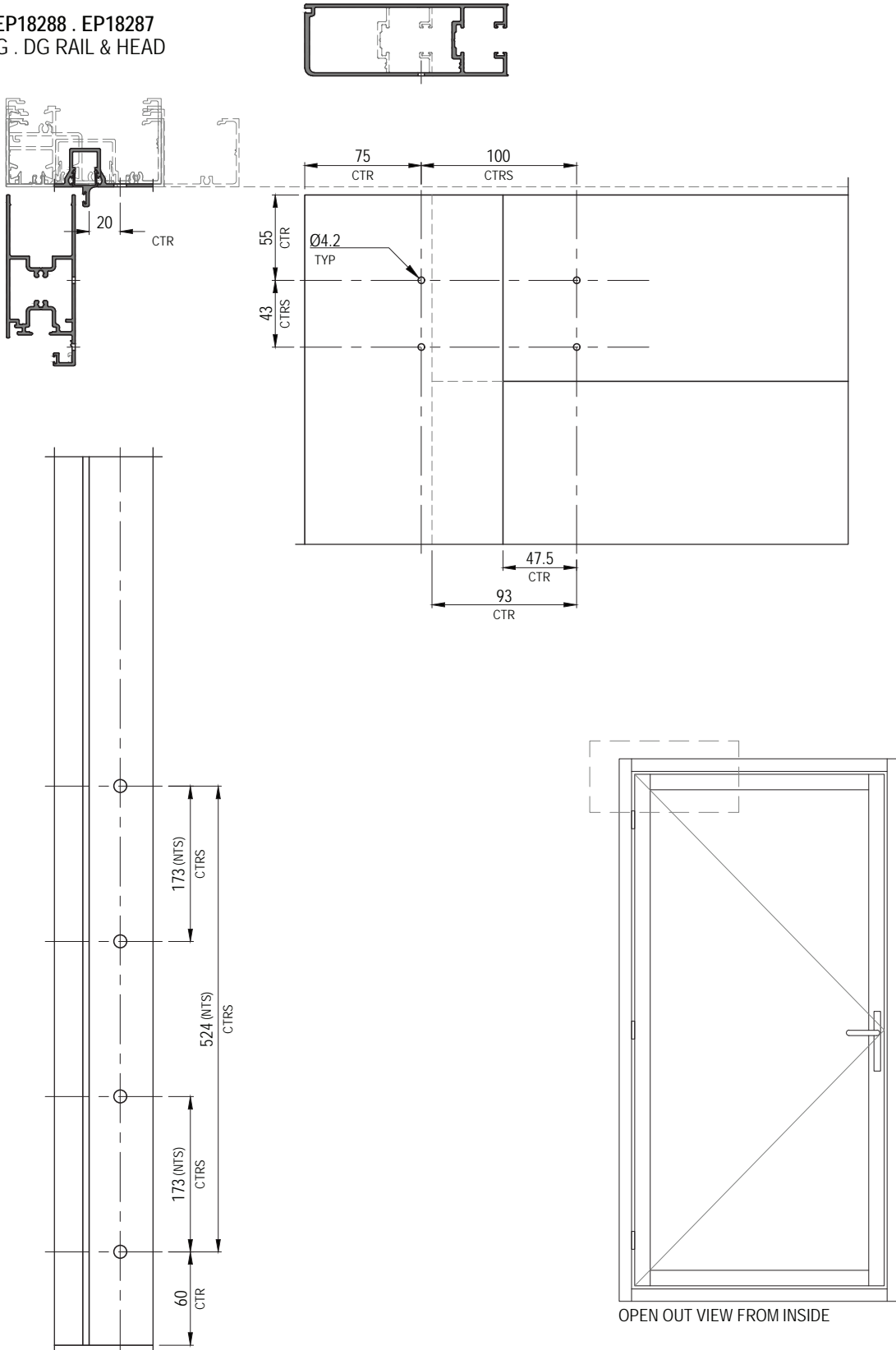

Please read in conjunction with Important Conditions – Index (also available on Capral website)

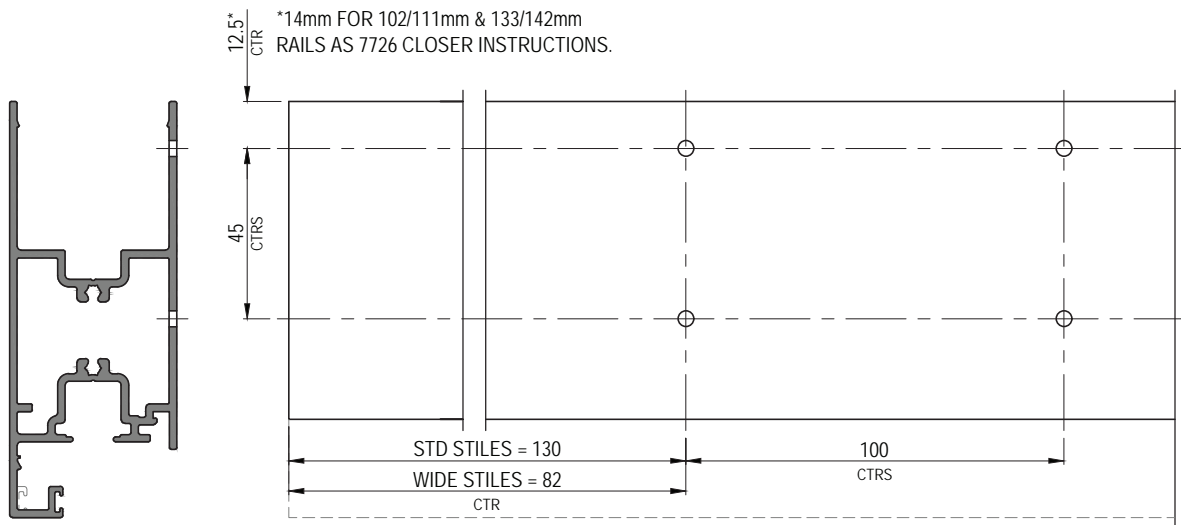
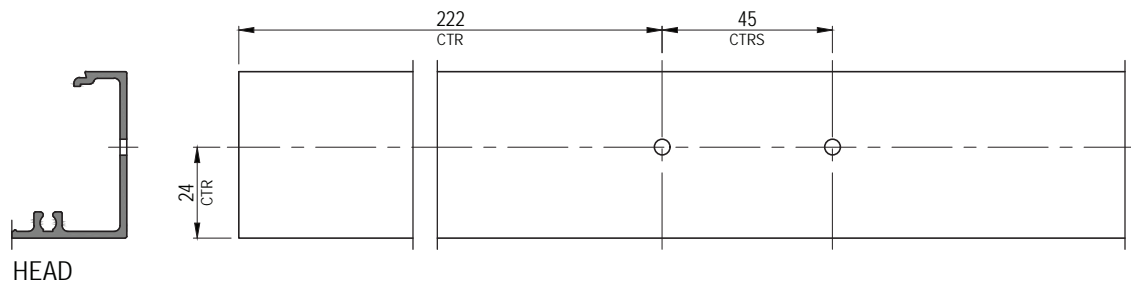

EP18288 . EP14889
SG . DG RAILS

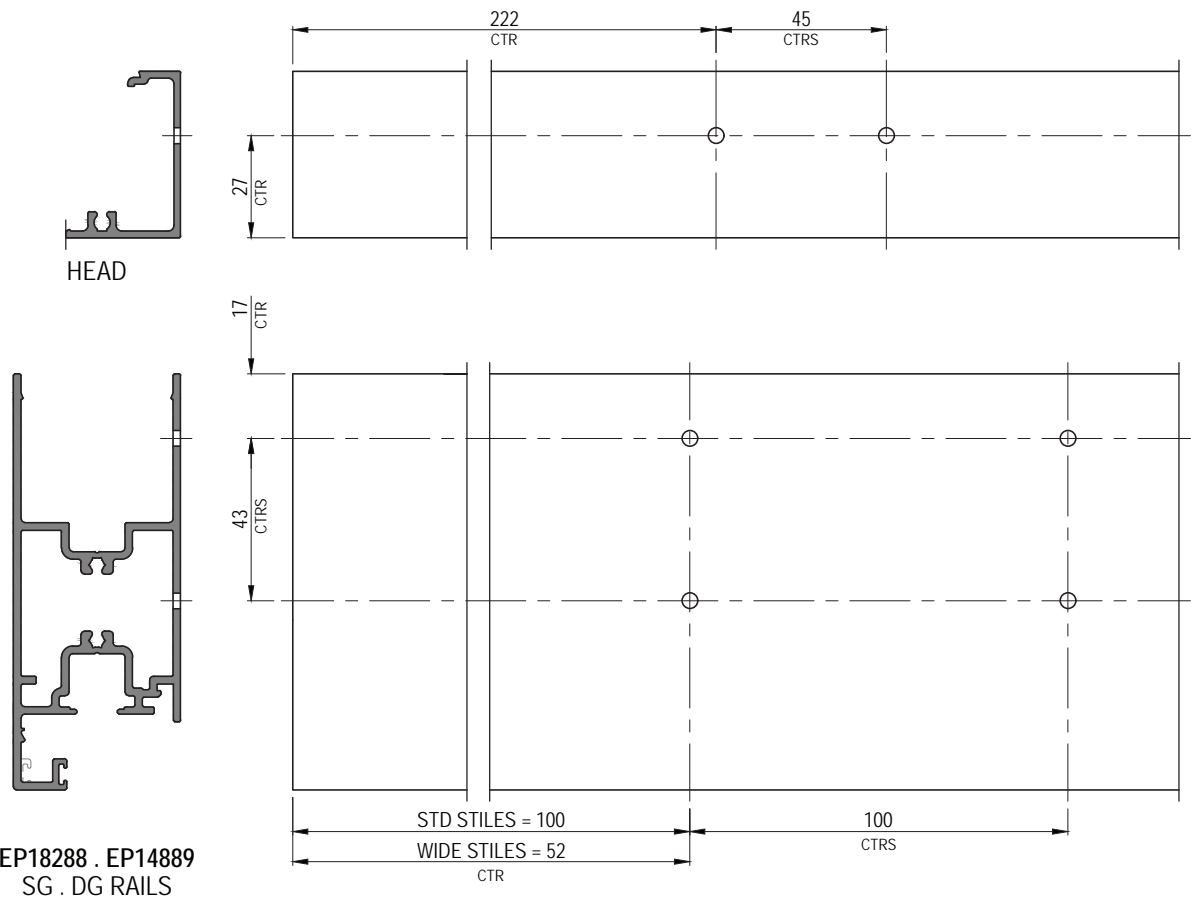

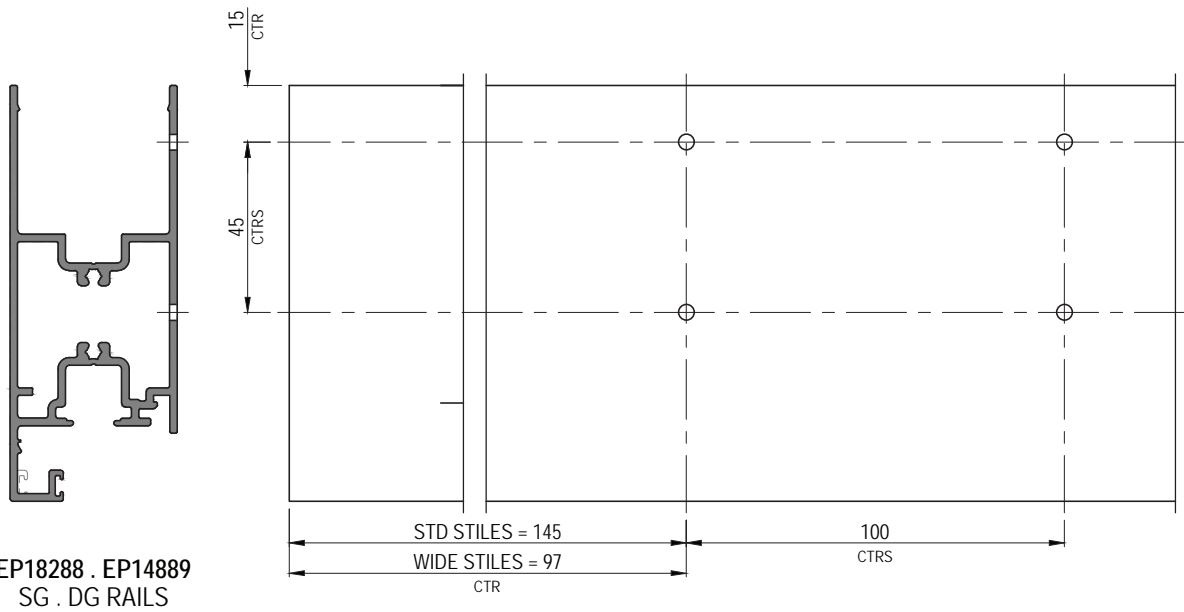
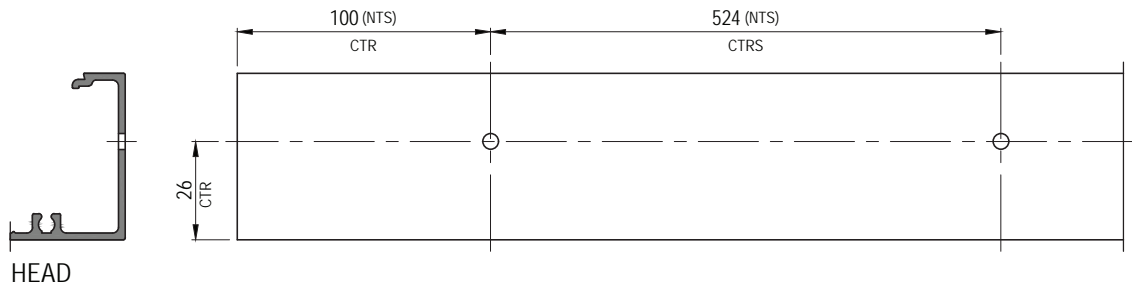

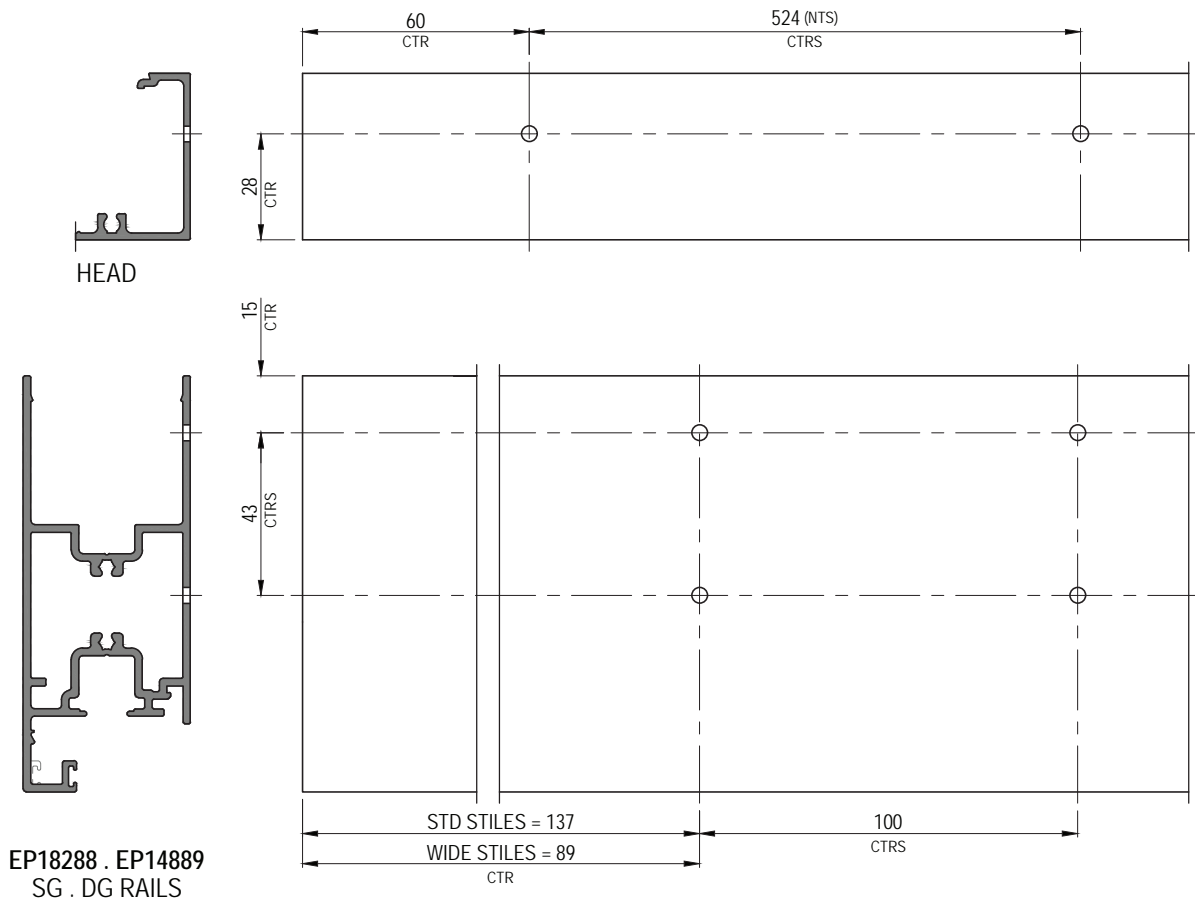

Assembly - Euro Bracket & Jacking Screw Panel

Not To Scale

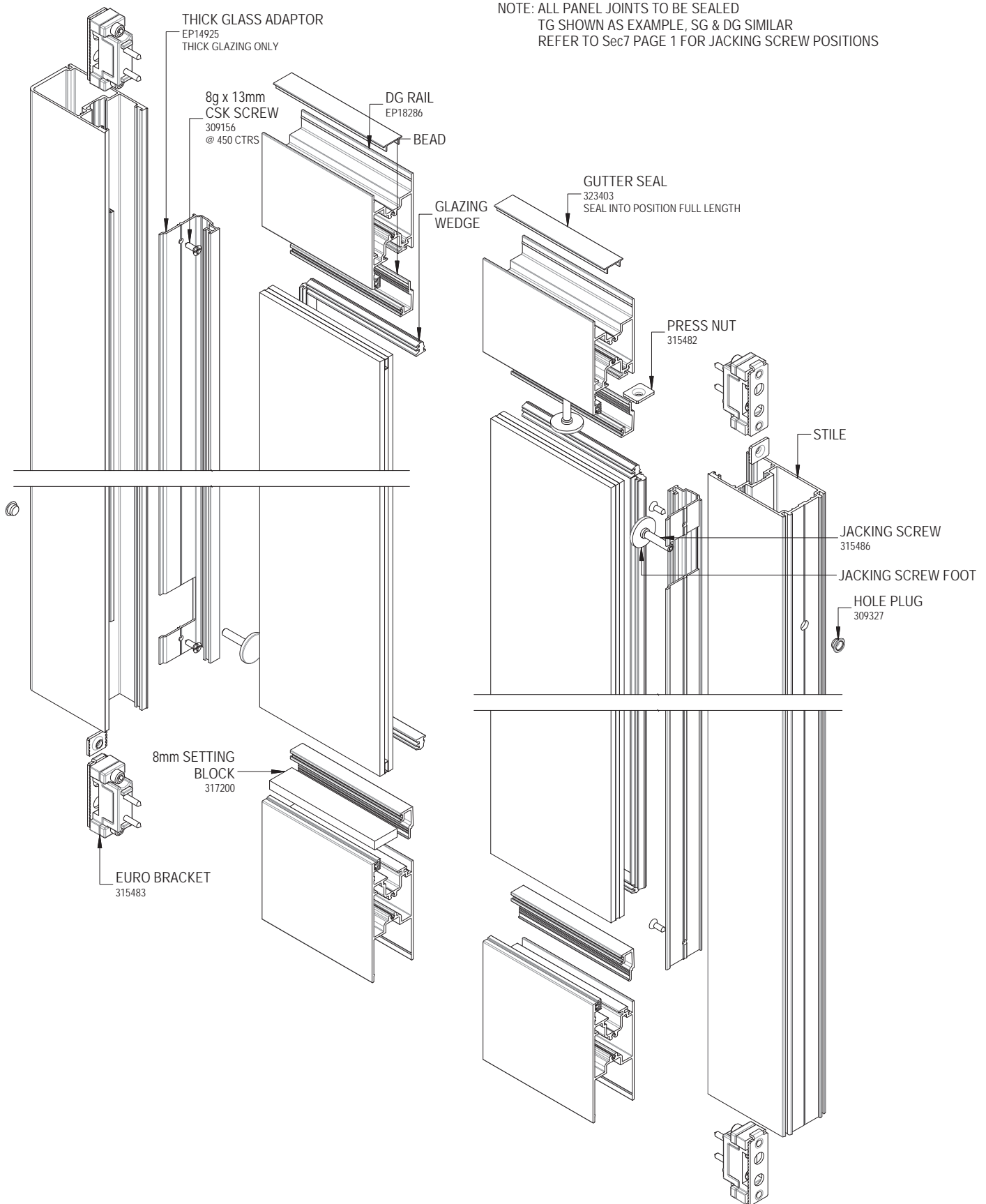

Please read in conjunction with Important Conditions – Index (also available on Capral website)

Assembly - Euro Bracket

Not To Scale

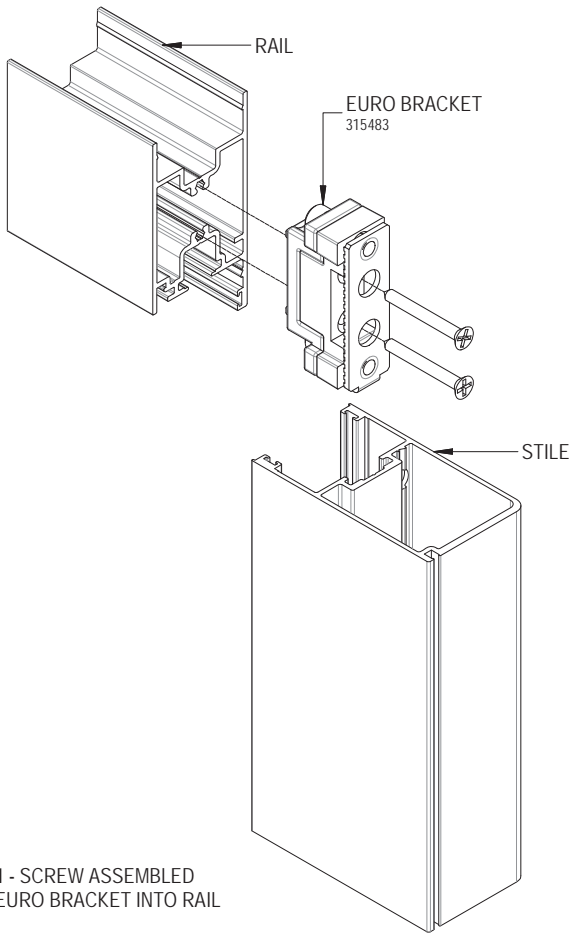

1 - SCREW ASSEMBLED
EURO BRACKET INTO RAIL

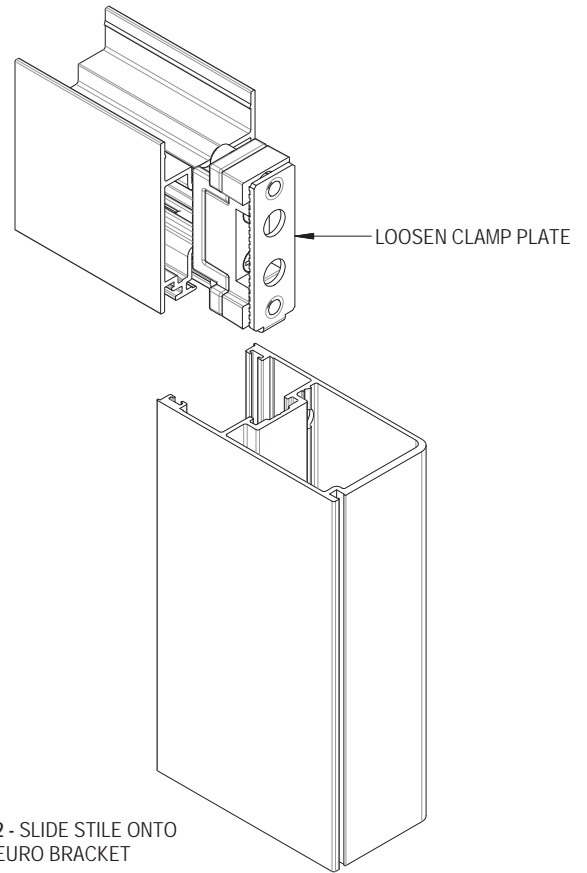

2 - SLIDE STILE ONTO
EURO BRACKET

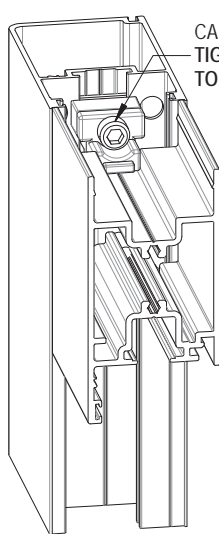

3 - TIGHTEN CAP SCREW
ABOVE AND BELOW THE
RAILS

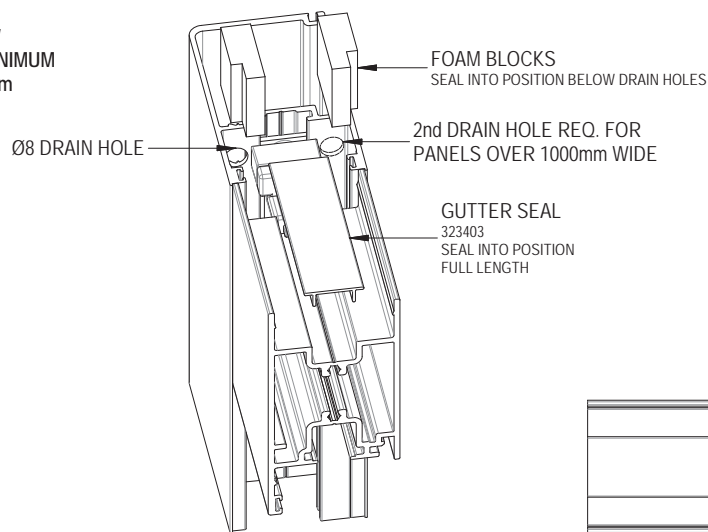

4 - FILL STILE POCKET EITHER
SIDE OF EURO BRACKET
LEVEL WITH DRAIN HOLES
AND COVER RAIL CHANNEL
WITH GUTTER SEAL

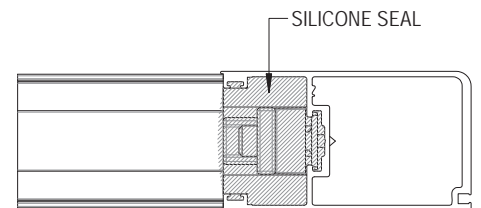

5 - COMPLETELY SEAL
STILE POCKET OVER AND
AROUND EURO BRACKET

Please read in conjunction with Important Conditions – Index (also available on Capral website)

Assembly - Spigot & Block Glazing Panel

Not To Scale

NOTE: ALL PANEL JOINTS TO BE SEALED
 DG PANEL SHOWN AS EXAMPLE, SG & TG SIMILAR

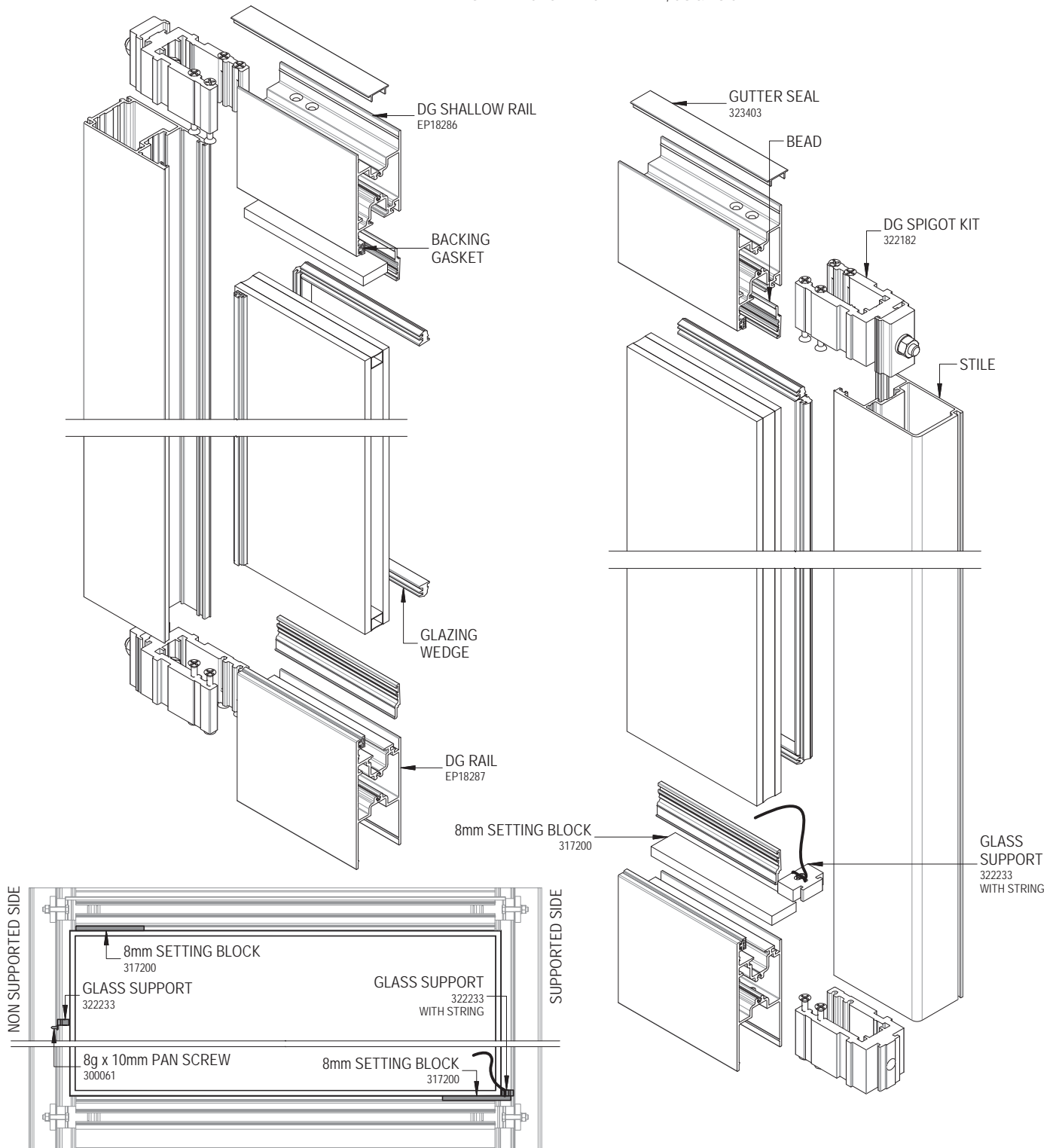

BLOCK GLAZING

- ON THE SUPPORTED SIDE TIE STRING AROUND GLASS SUPPORT 322233 AND SLIDE INTO RAIL
- ON NON SUPPORTED SIDE INSERT GLASS SUPPORT 322233 AND POSITION WITH 300061 SCREW
- ASSEMBLE THE STILES & RAILS (SPIGOT ASSEMBLY SHOWN, EURO BRACKET ASSEMBLY AS PREVIOUS PAGE)
- SHUFFLE GLASS INTO THE STILES UNTIL IT MEETS THE GLASS SUPPORT IN THE NON SUPPORTED SIDE STILE
- LIFT GLASS AND PLACE 8mm SETTING BLOCK 317200 UNDER GLASS AT THE SUPPORTED SIDE
- USE THE STRING TO LIFT THE GLASS SUPPORT AND SLIDE SETTING BLOCK ALL THE WAY INTO THE STILE POCKET TO POSITION GLASS SUPPORT
- LOWER GLASS, INSERT TOP 8mm SETTING BLOCK ON NON SUPPORTED SIDE AND CUT/CONCEAL STRING

Please read in conjunction with Important Conditions – Index (also available on Capral website)

Assembly - Spigot Kits & Tie Rod

Not To Scale

SPIGOT KITS

USE EURO BRACKET WITH MIDRAILS (EXCLUDING 50mm MIDRAIL)

DG SPIGOT KIT
322182

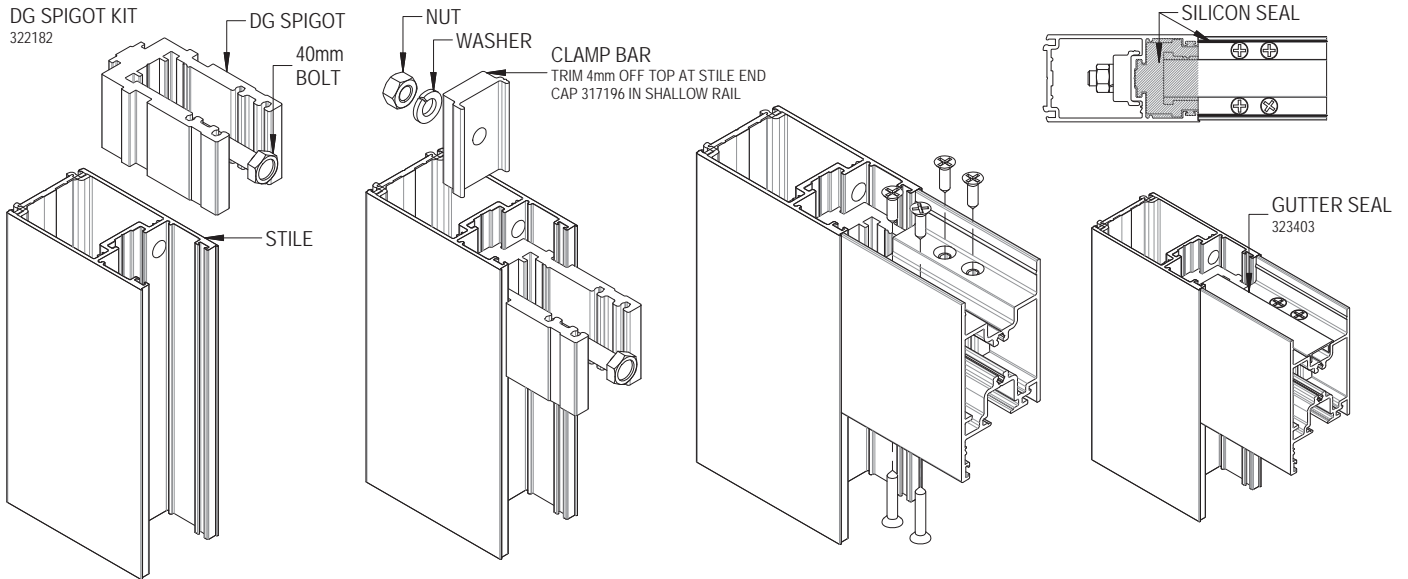

1 - SLIDE SPIGOT INTO STILE AND INSERT BOLT THROUGH BOTH

2 - ADD CLAMP BAR AND WASHER TO BOLT IN INSIDE OF STILE AND LOOSELY APPLY NUT.

3 - SLIDE RAIL ONTO SPIGOT AND SECURE INTO POSITION WITH A SASH CLAMP THEN FIT AND TIGHTEN ALL FASTENERS BEFORE REMOVING CLAMP

4 - SEAL GUTTER SEAL INTO PLACE AND COMPLETELY SEAL OVER POCKET

SG SPIGOT KIT
322183
ASSEMBLY AS ABOVE

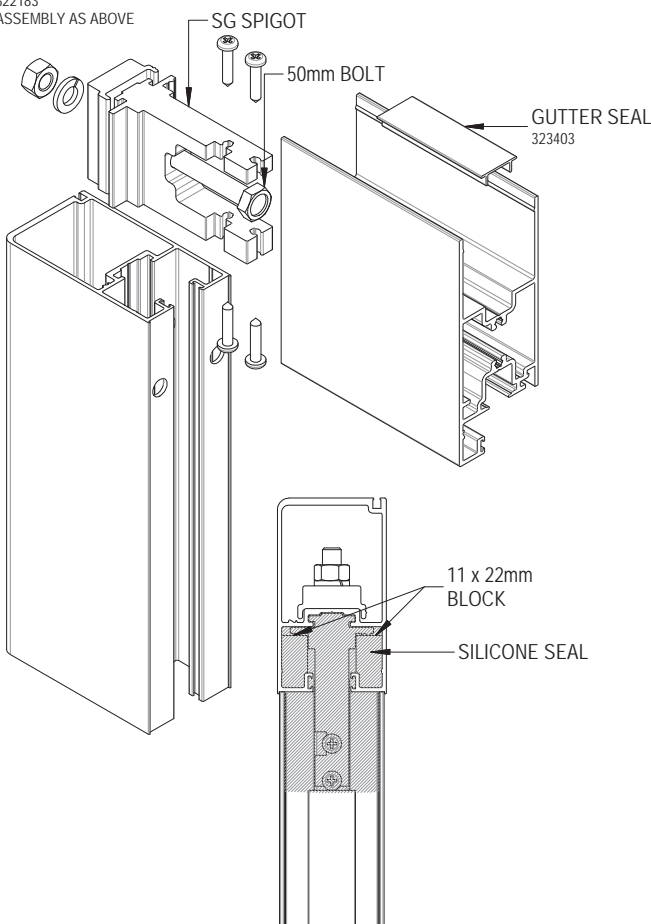

TIE ROD
SEAL AS ABOVE

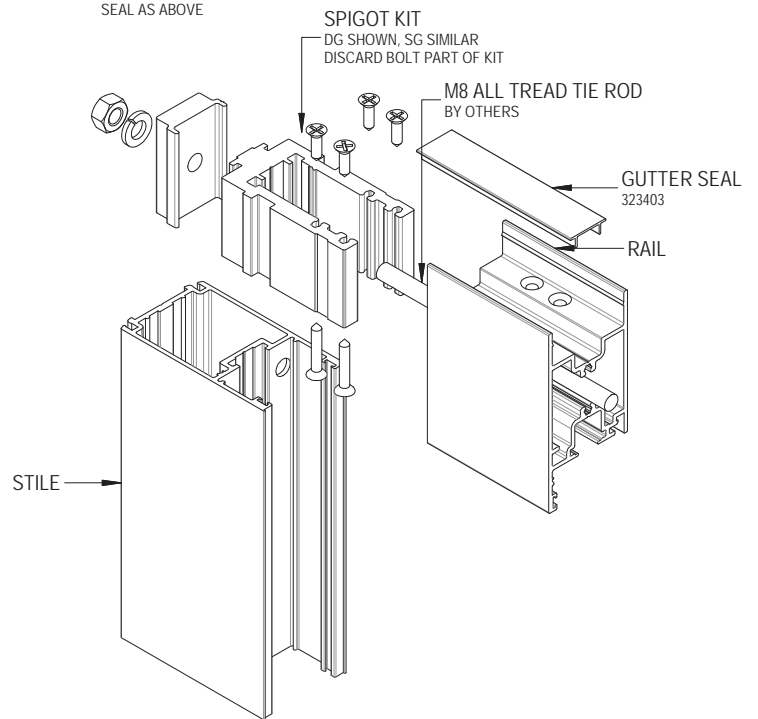

Please read in conjunction with Important Conditions – Index (also available on Capral website)

Assembly - 110mm & Coupled Midrails

Not To Scale

NOTE: ALL PANEL JOINTS TO BE SEALED

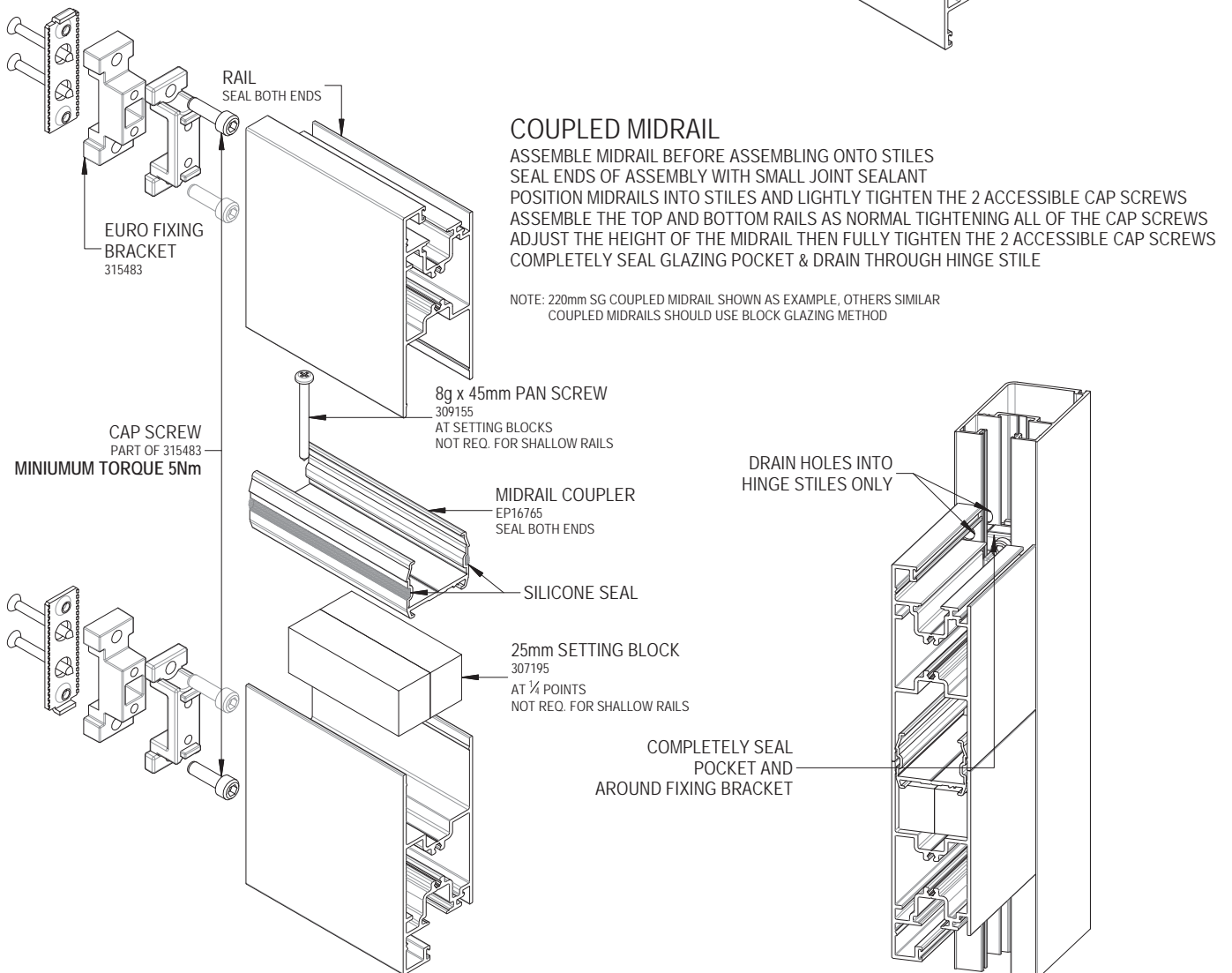
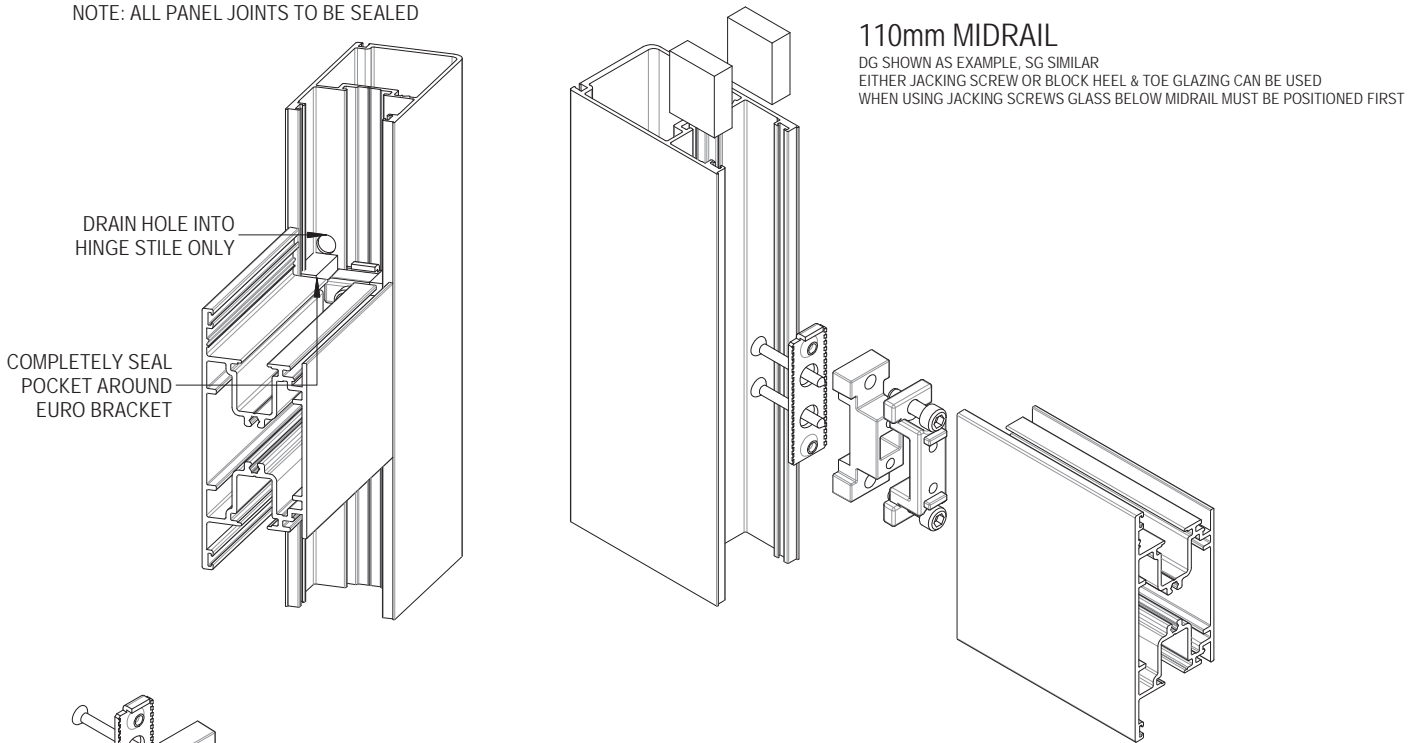

Please read in conjunction with Important Conditions – Index (also available on Capral website)

Assembly - 50mm Midrail

Not To Scale

NOTE: SG SHOWN AS EXAMPLE, TG & DG SIMILAR.
LOCK CAN NOT BE IN THE SAME POSITION AS THE MIDRAIL BRACKET

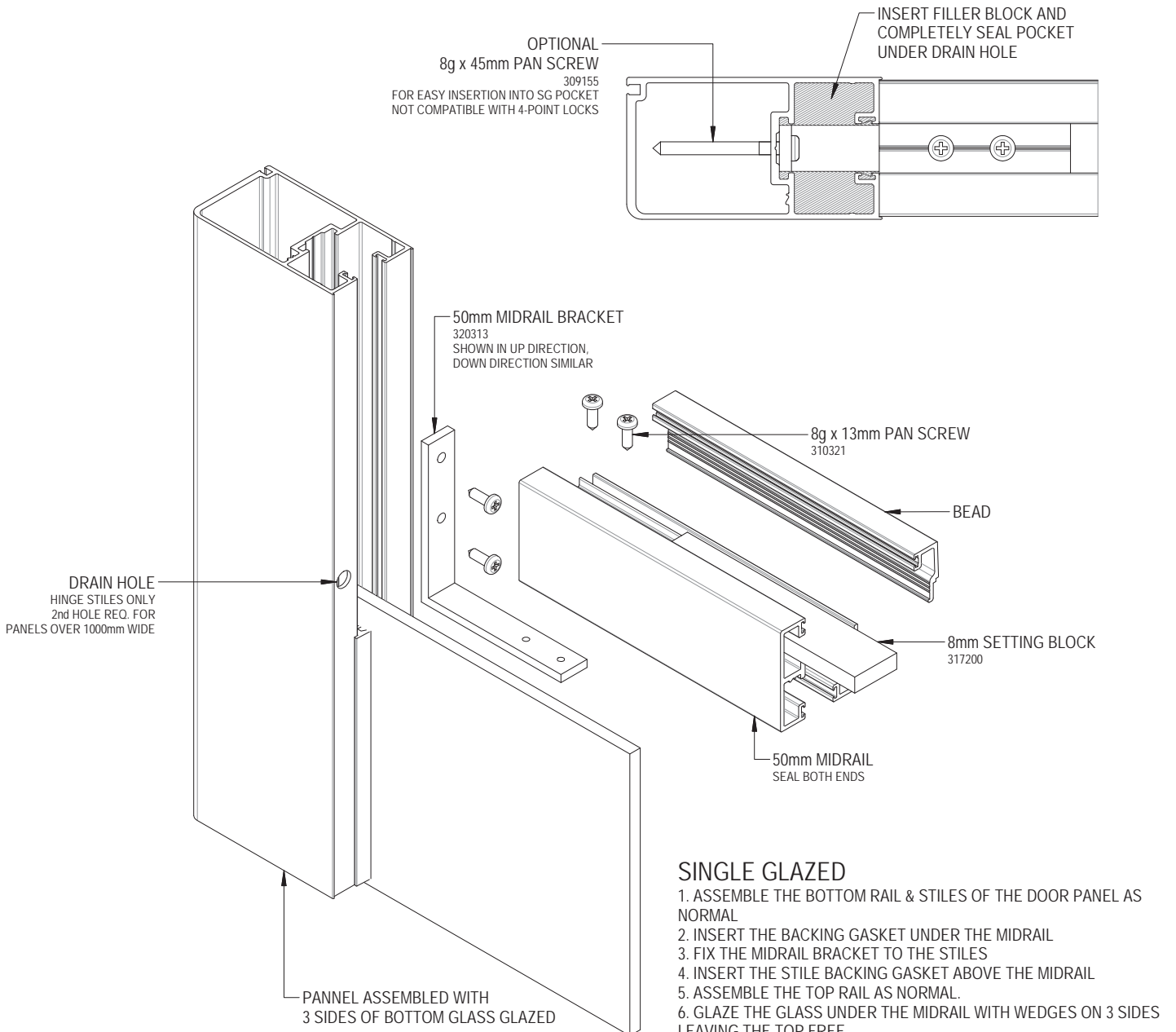

SINGLE GLAZED

1. ASSEMBLE THE BOTTOM RAIL & STILES OF THE DOOR PANEL AS NORMAL
2. INSERT THE BACKING GASKET UNDER THE MIDRAIL
3. FIX THE MIDRAIL BRACKET TO THE STILES
4. INSERT THE STILE BACKING GASKET ABOVE THE MIDRAIL
5. ASSEMBLE THE TOP RAIL AS NORMAL
6. GLAZE THE GLASS UNDER THE MIDRAIL WITH WEDGES ON 3 SIDES LEAVING THE TOP FREE
7. WITH THE UPPER SUPPORT BLOCK IN POSITION (SEE HEAL & TOE DIAGRAM) PLACE THE MIDRAIL ONTO THE BRACKETS AND FIX
8. COMPLETELY SEAL THE STILE POCKETS AROUND THE MIDRAIL BRACKET UNDER THE DRAIN HOLE
9. FINISH GLAZING THE BOTTOM GLASS
10. GLAZE THE TOP GLASS OR REPEAT FOR MULTIPLE MIDRAILS

BLOCK HEAL & TOE GLAZING

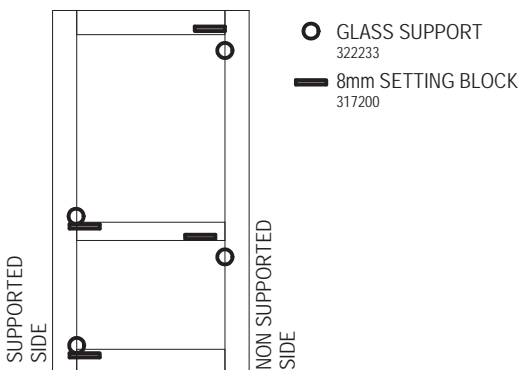

OPTIONAL DOUBLE / THICK GLAZED

1. ASSEMBLE THE RAILS & STILES OF THE DOOR PANEL AS NORMAL
2. FIX THE MIDRAIL BRACKET TO THE STILES
3. SEE SG STEPS 6 - 10

Assembly - Slatted Panel

Not To Scale

NOTE: PANEL ASSEMBLY & GLAZING METHOD NOT SHOWN FOR CLARITY. REFER TO Sec6 PAGES 1 - 4

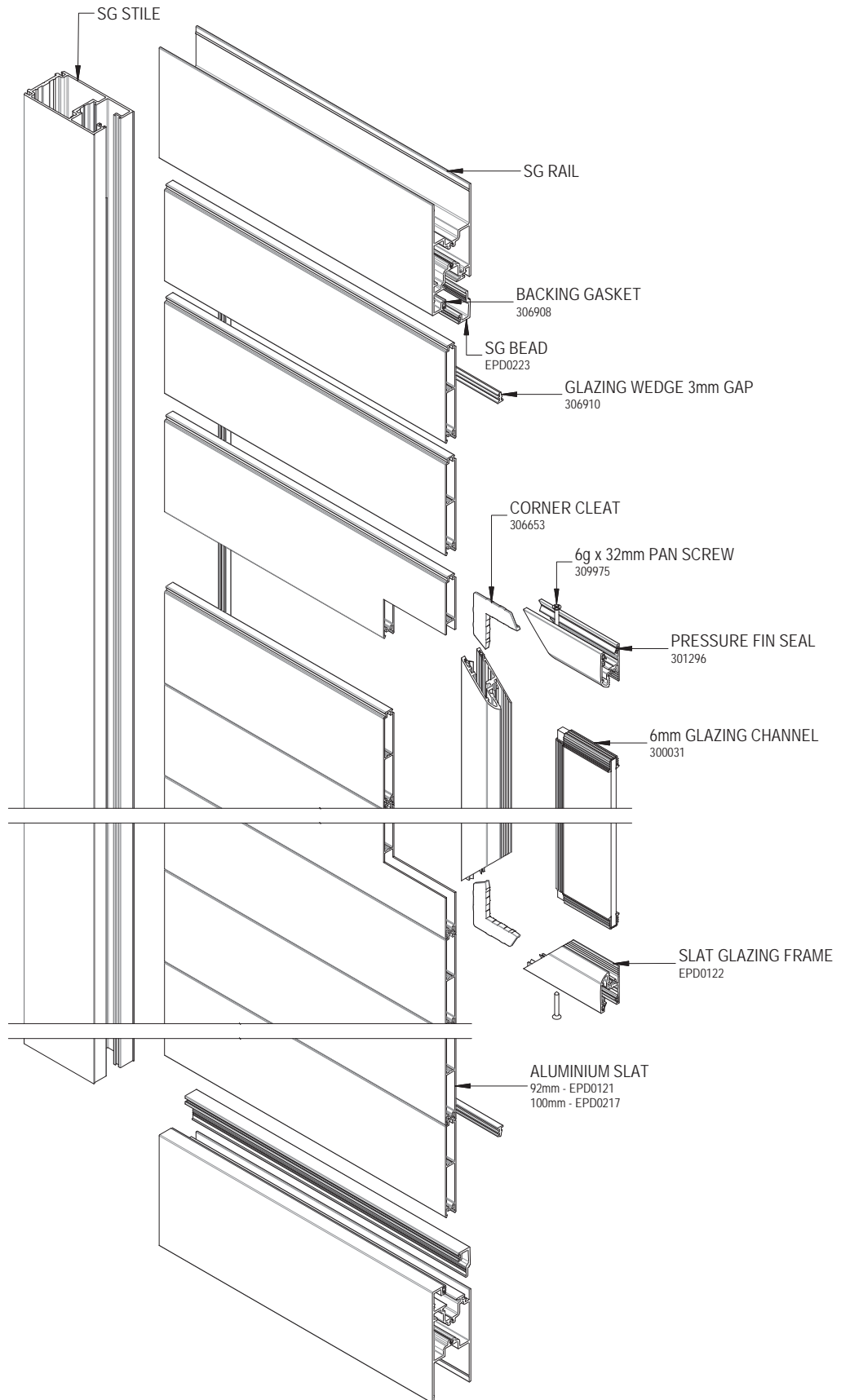

Please read in conjunction with Important Conditions – Index (also available on Capral website)

Assembly - Louvre Panel & Finger Pull

Not To Scale

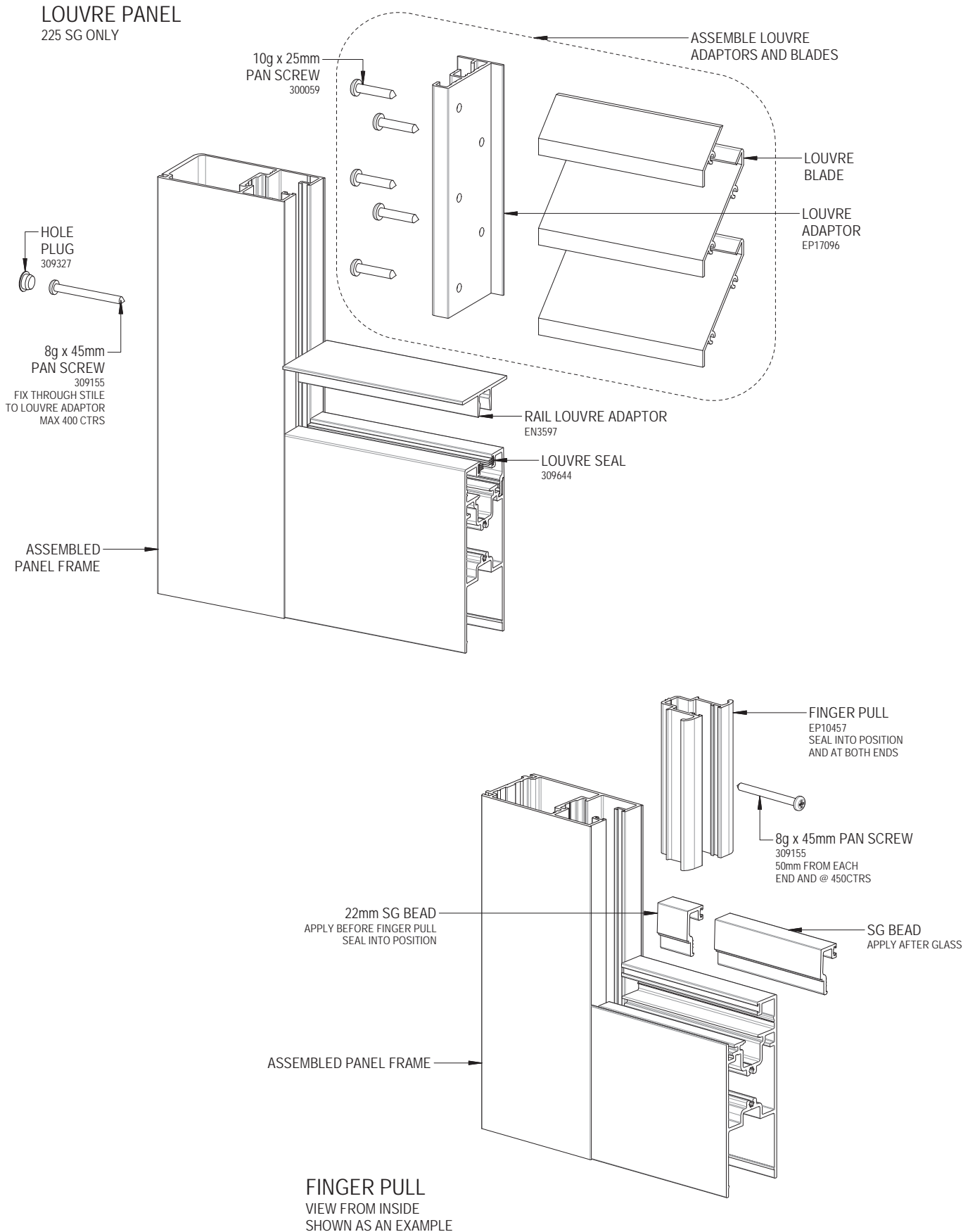

Please read in conjunction with Important Conditions – Index (also available on Capral website)

Assembly - Head Rollers

Not To Scale

1061 HEAD ROLLER

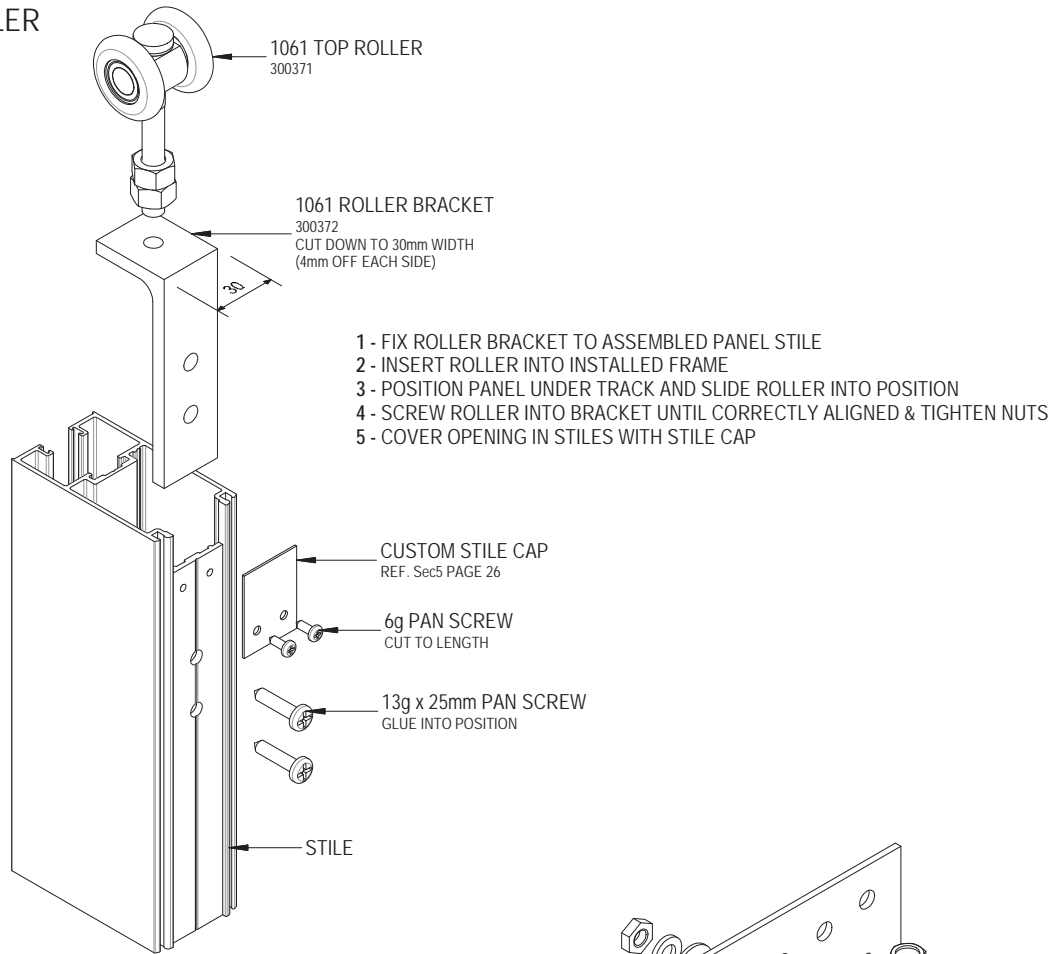

1031 HEAD ROLLER

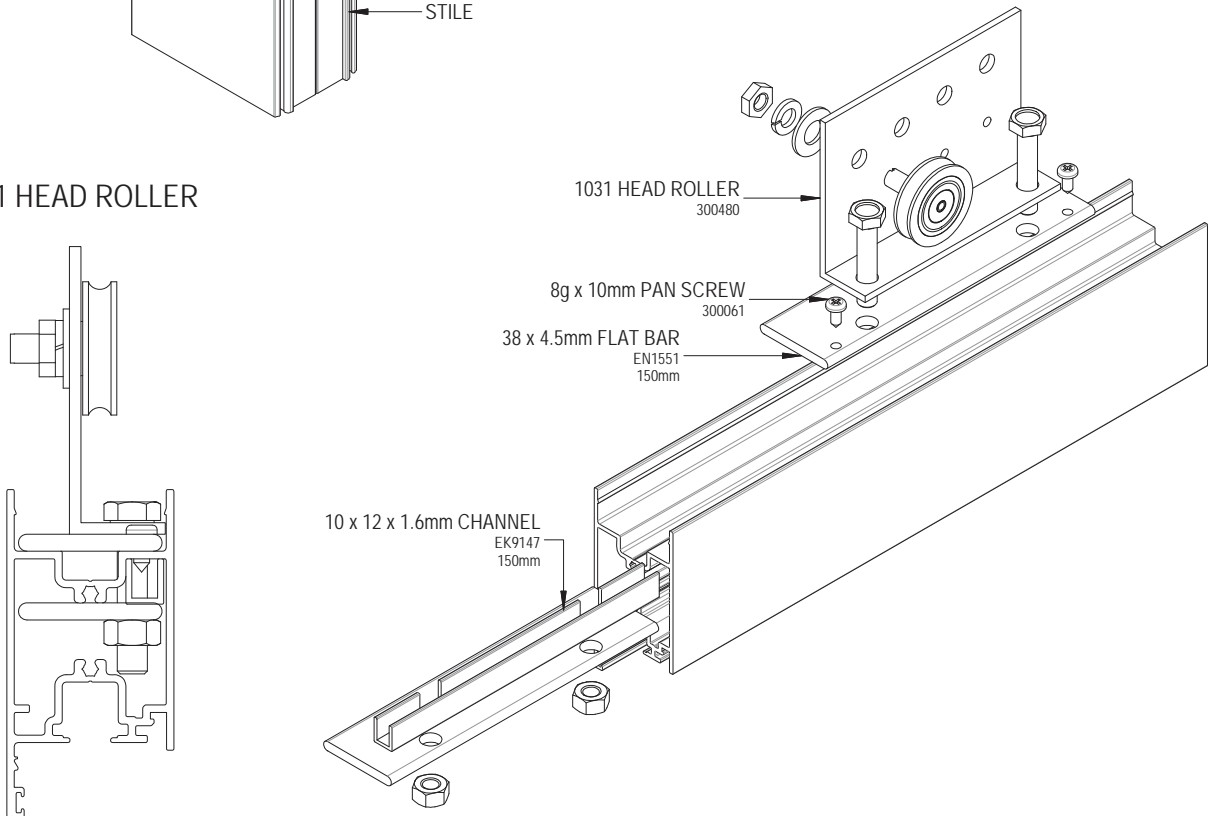

Please read in conjunction with Important Conditions – Index (also available on Capral website)

Assembly - Flush Bolt

Not To Scale

NOTE: DG MEETING STILE SHOWN AS EXAMPLE, OTHERS SIMILAR

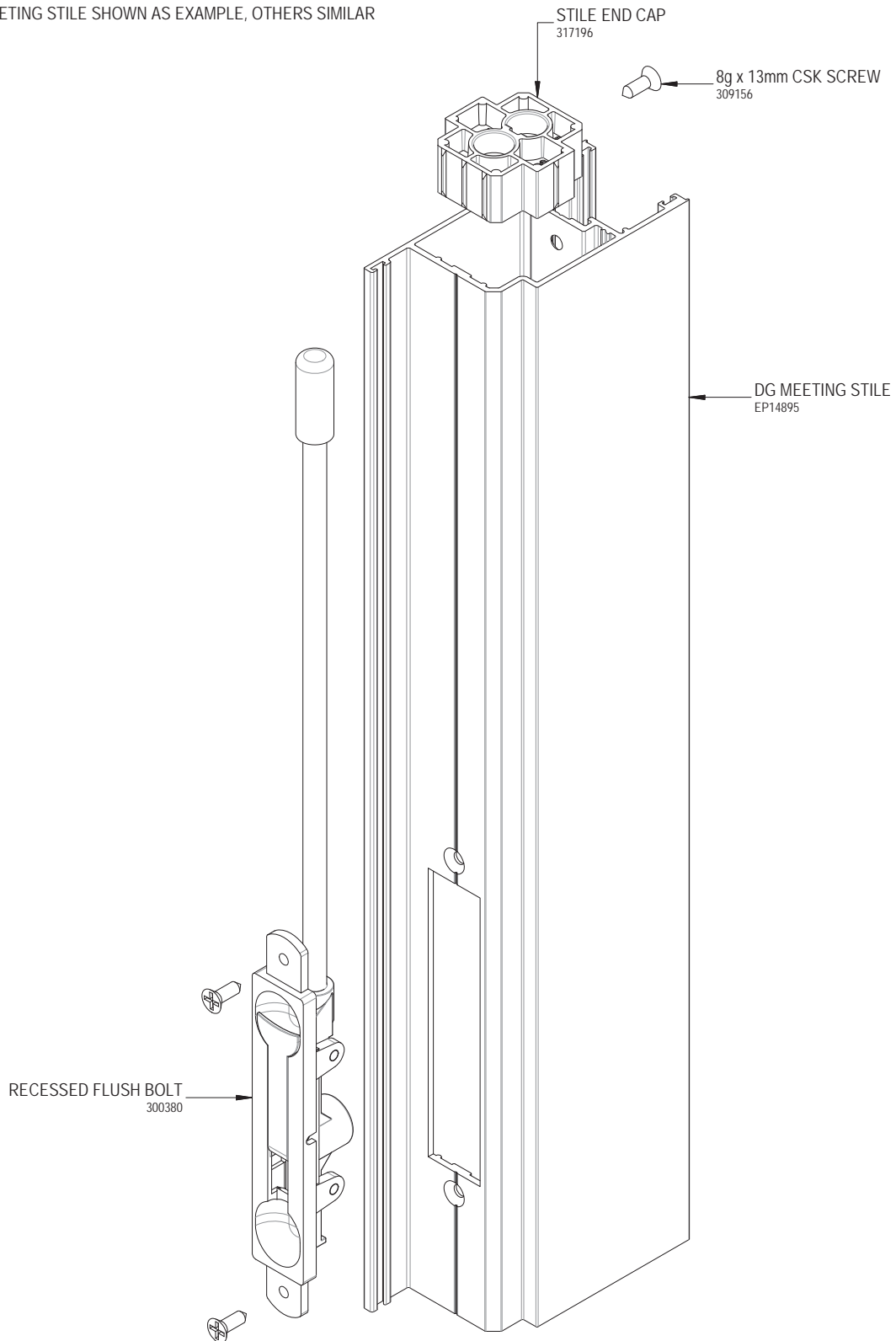

Please read in conjunction with Important Conditions – Index (also available on Capral website)

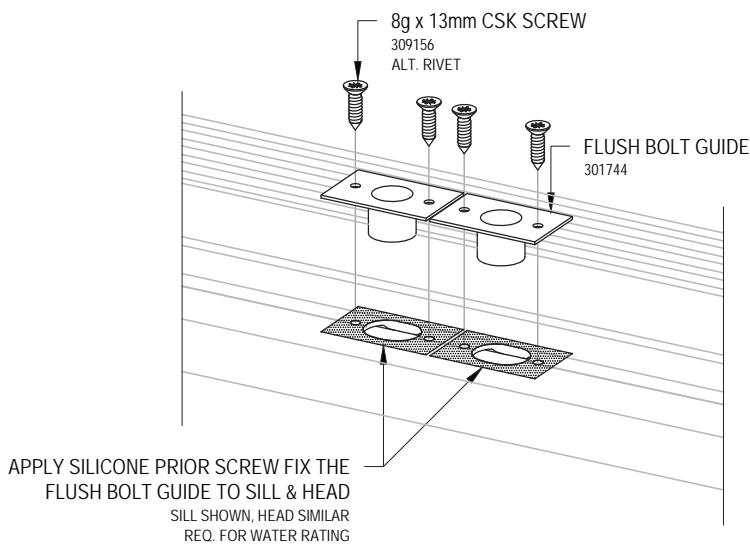
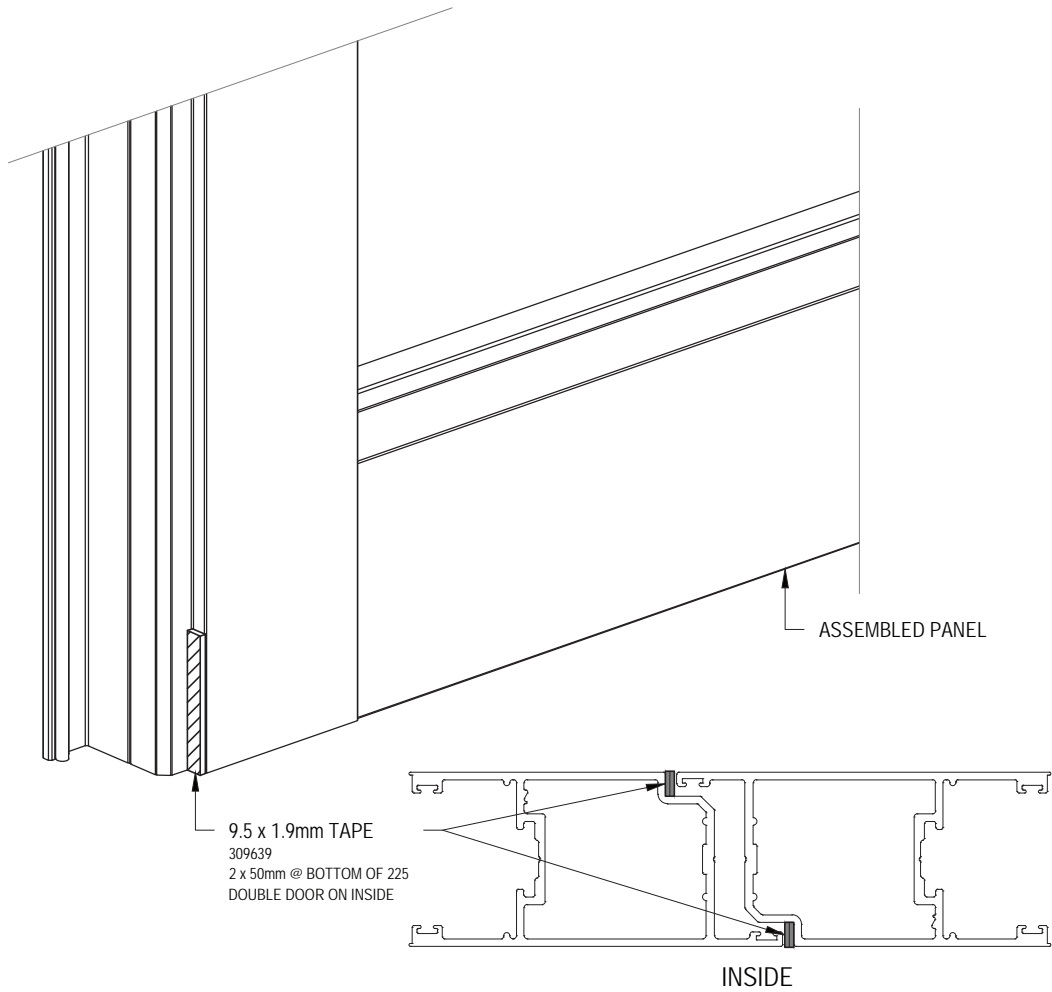

Please read in conjunction with Important Conditions – Index (also available on Capral website)

Assembly - 3570 Mortice Lock

Not To Scale

NOTE: FOR WIDE STILES ONLY
HANDLE NOT SHOWN FOR CLARITY
THIS IS A NON STOCKED ITEM

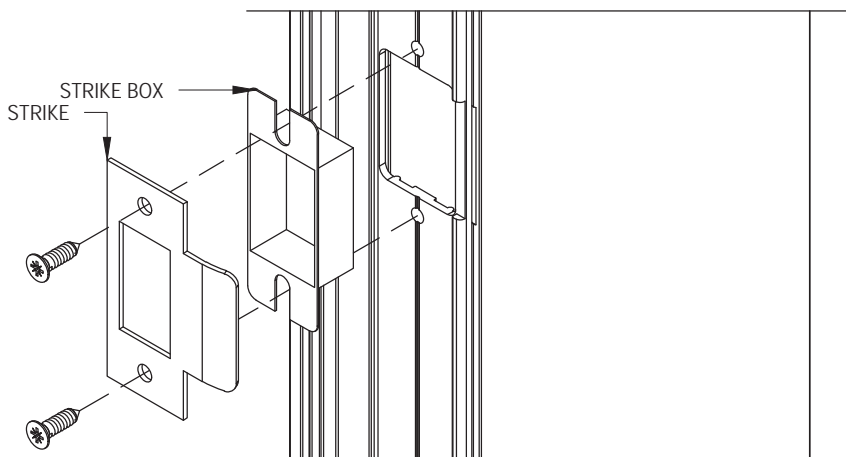
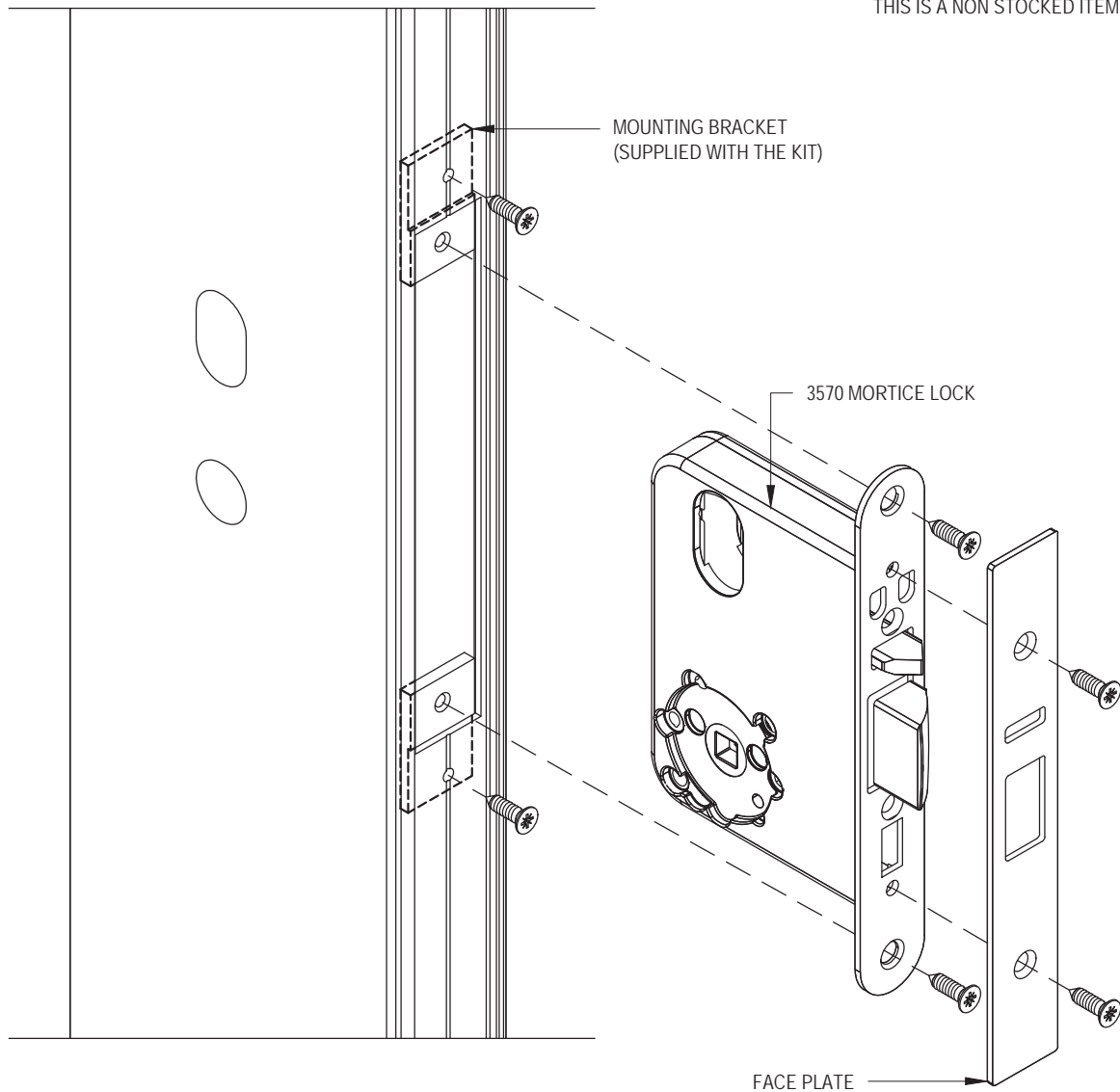

Please read in conjunction with Important Conditions – Index (also available on Capral website)

Assembly - Optimum & LCL Locks

Not To Scale

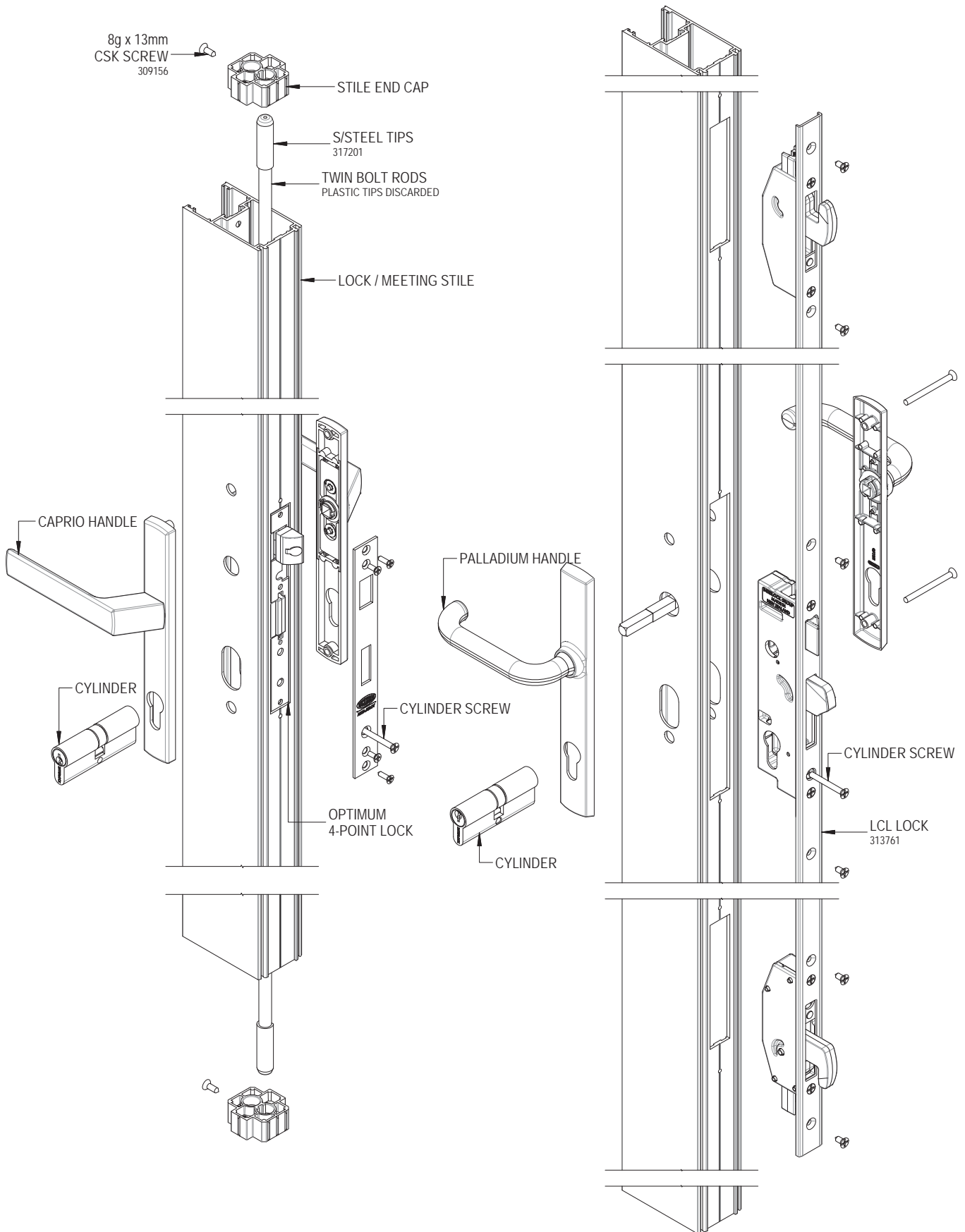

Please read in conjunction with Important Conditions – Index (also available on Capral website)

Assembly - Selector & 3541 Mortice Locks

Not To Scale

SELECTOR LOCK
 REFER TO MANUFACTURERS
 INSTRUCTIONS FOR FULL DETAILS

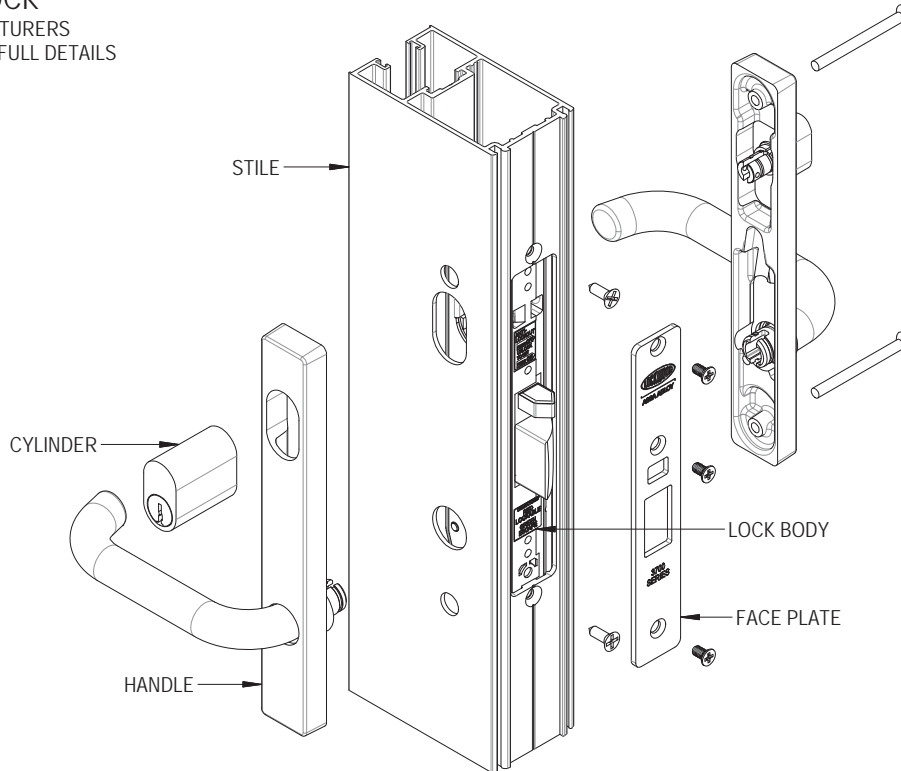

3541 MORTICE LOCK

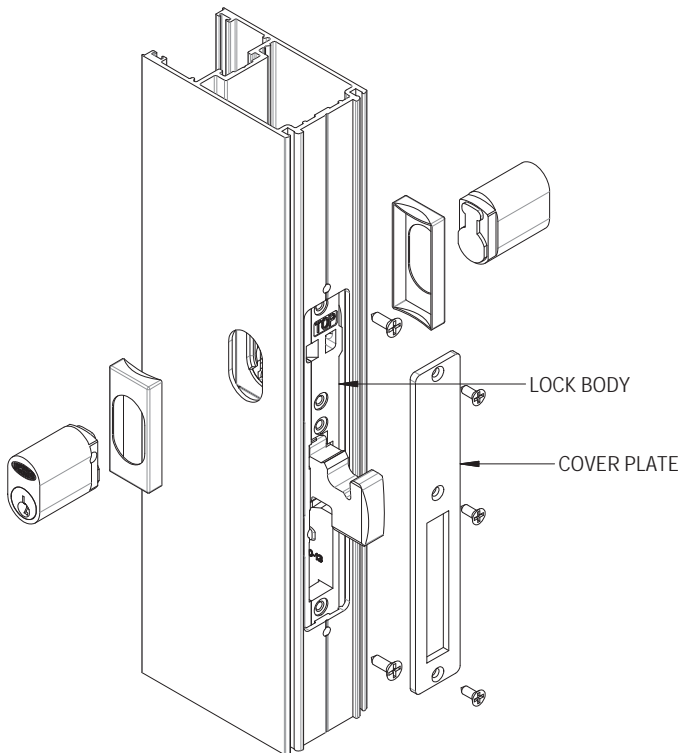

3541 MORTICE LOCK

SIDE MOUNT
 DISCARD SECOND CYLINDER

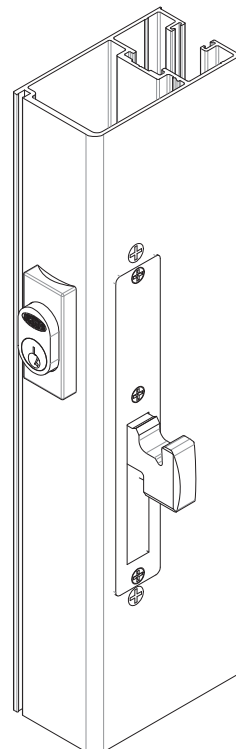

Please read in conjunction with Important Conditions – Index (also available on Capral website)

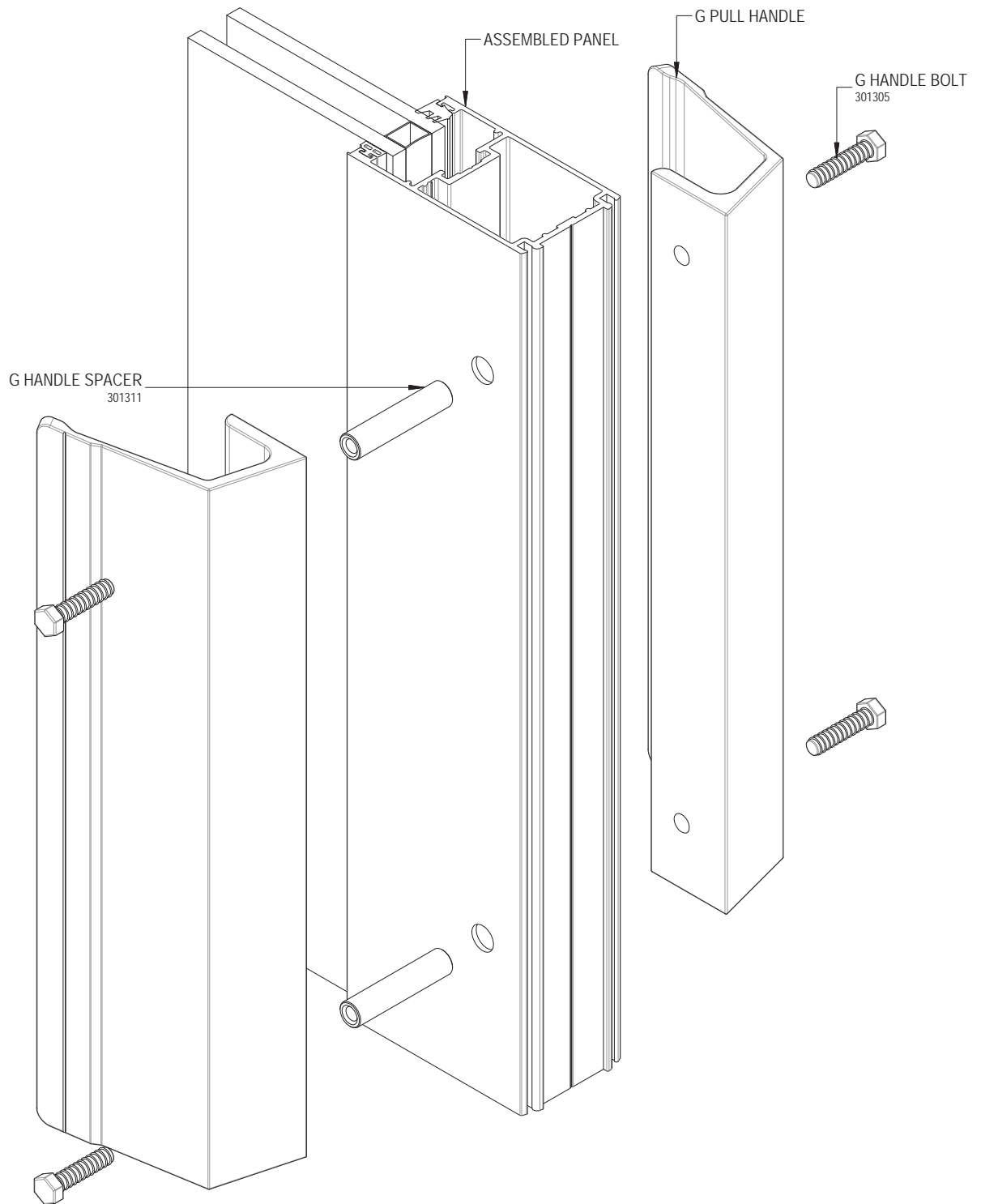

Please read in conjunction with Important Conditions – Index (also available on Capral website)

Assembly - Door Stop

Not To Scale

NOTE: 400 FRAME & DOOR STOP SHOWN AS EXAMPLE, OTHERS SIMILAR
 ALL FRAME JOINTS & DOOR STOPS TO BE SEALED
 REFER TO RESPECTIVE FRAMING TECHNICAL MANUALS FOR FURTHER FRAME ASSEMBLY INFORMATION

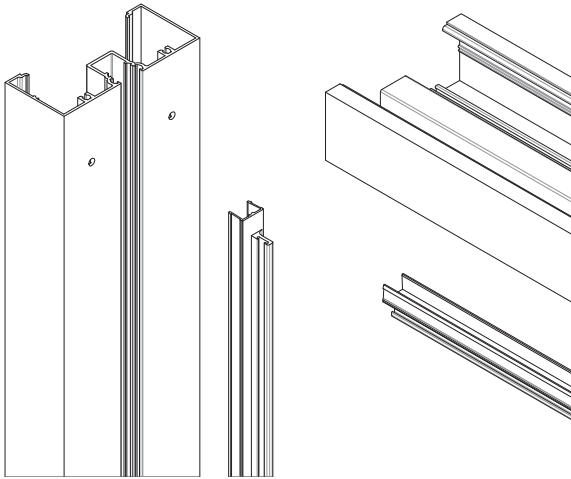

HEAD OPTION 1 - NOTCHED

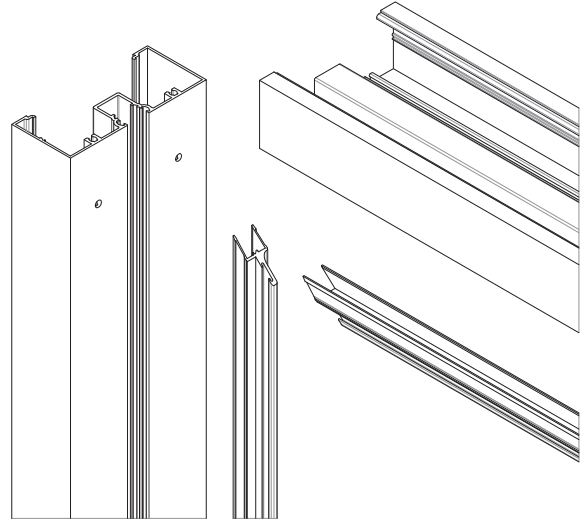

HEAD OPTION 2 - MITRED

THRESHOLD OPTION 1 - NOTCHED

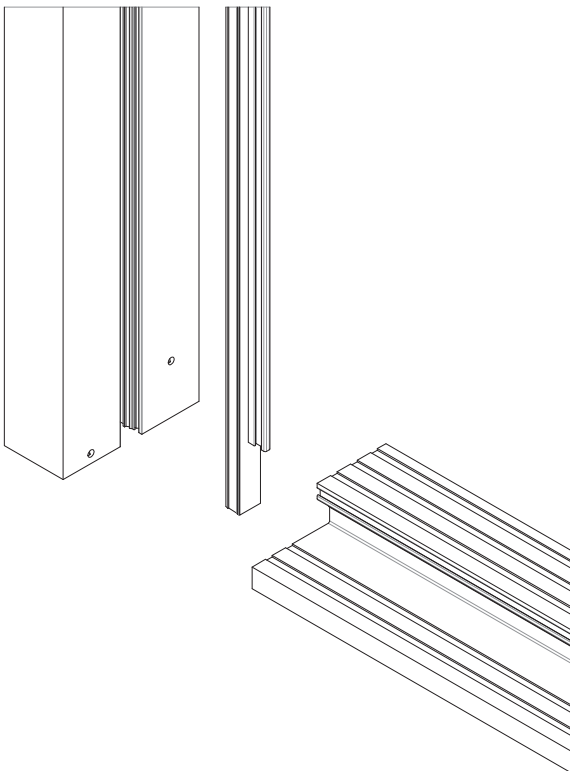

THRESHOLD OPTION 2 - SQ. CUT + FILLER

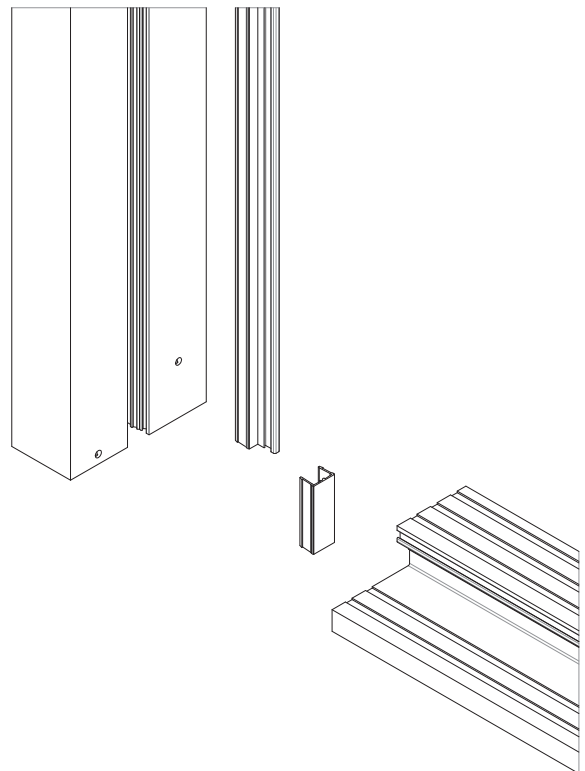

Assembly - Concealed Overhead Closer Frame

Not To Scale

NOTE: CAN ONLY BE USED WITH 225 82mm STILES.
 ALL ITEMS EXCLUDING FRAME & ASSEMBLED PANEL ARE PART OF 9800
 CONCEALED OVERHEAD CLOSER. REFER TO PRODUCT INSTRUCTIONS
 FOR FURTHER INFORMATION. DG SHOWN AS EXAMPLE SG SIMILAR. NOT
 COMPATIBLE WITH WIDE STILES.

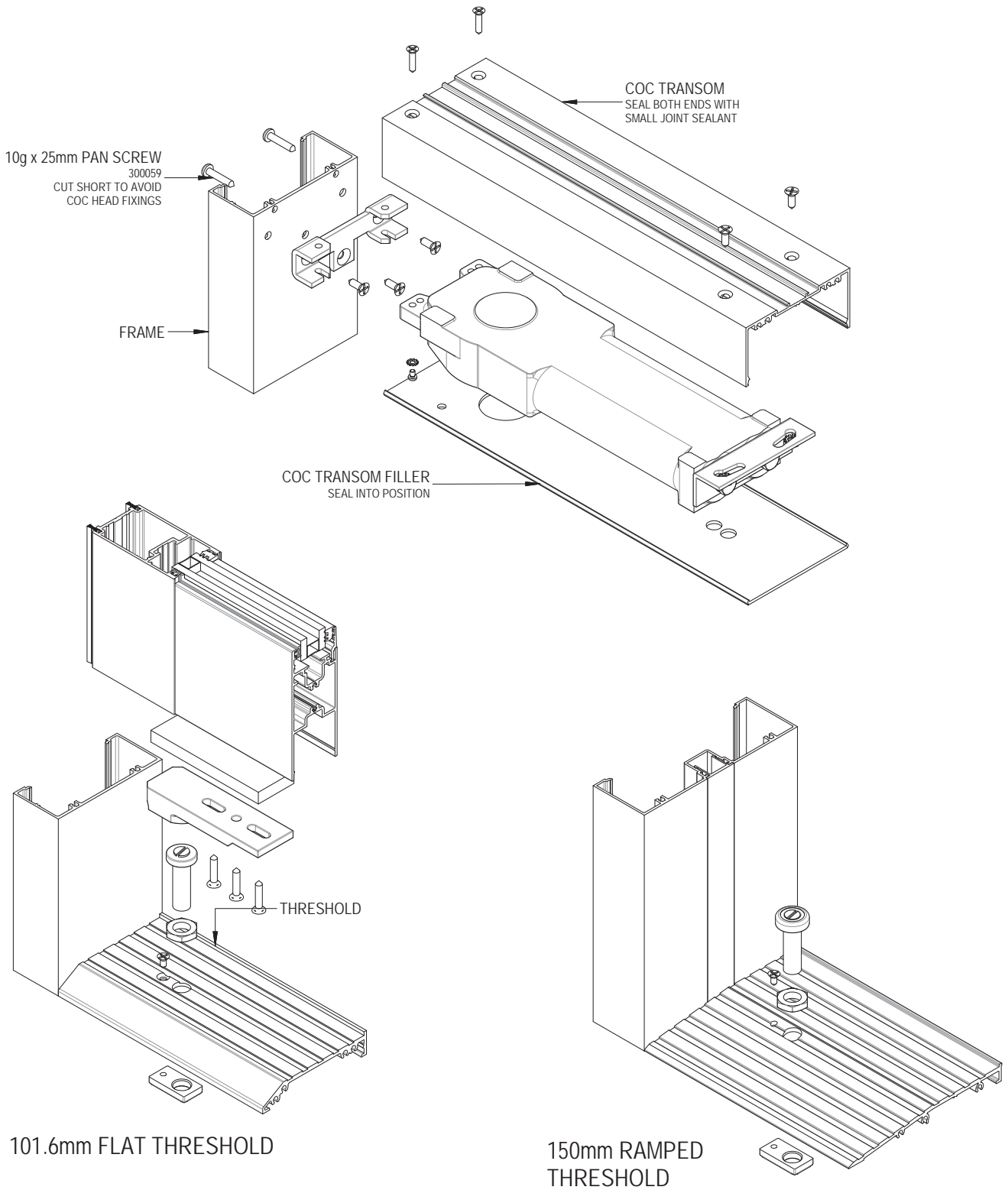

Please read in conjunction with Important Conditions – Index (also available on Capral website)

Assembly - Concealed Overhead Closer Panel

Not To Scale

NOTE: CAN ONLY BE USED WITH 83mm STILES.
 ALL ITEMS EXCLUDING FRAME & ASSEMBLED PANEL ARE PART OF 9800
 CONCEALED OVERHEAD CLOSER. REFER TO PRODUCT INSTRUCTIONS
 FOR FURTHER INFORMATION. DG SHOWN AS EXAMPLE SG SIMILAR. NOT
 COMPATIBLE WITH WIDE STILES.

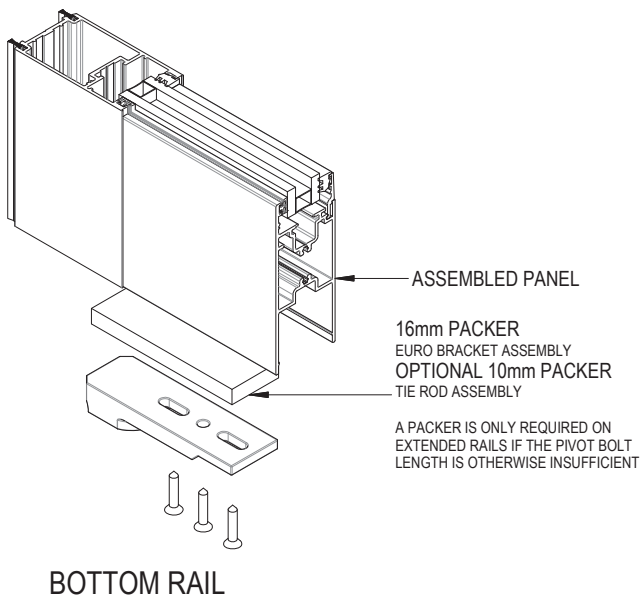
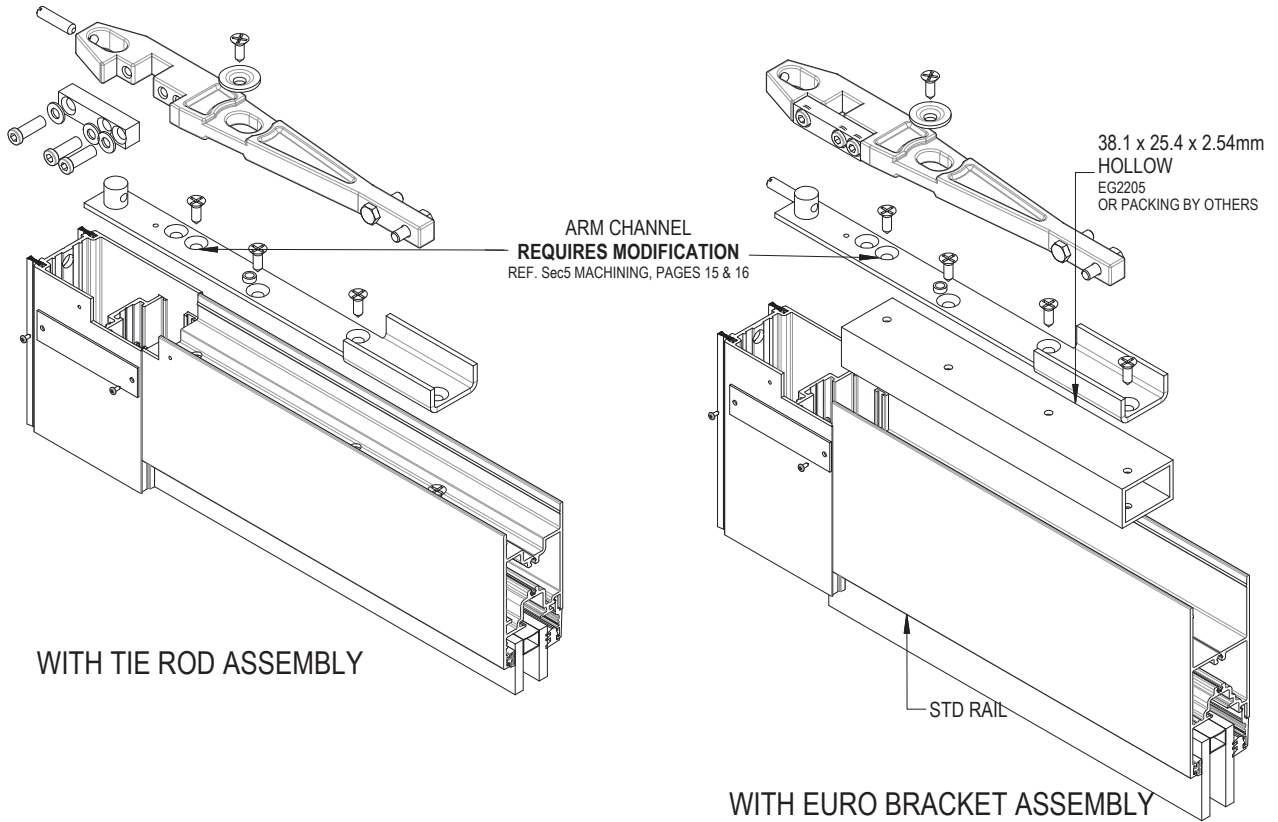

Please read in conjunction with Important Conditions – Index (also available on Capral website)

Assembly - Open Out Arm Door Closer

Not To Scale

NOTE: 7726 CLOSER SHOWN. 7714 CLOSER SIMILAR. ALL ITEMS EXCLUDING FRAME & ASSEMBLED PANEL ARE PART OF DOOR CLOSER. REFER TO PRODUCT INSTRUCTIONS FOR FURTHER INFORMATION.
NOT COMPATIBLE WITH SHALLOW TOP RAIL.
NOT COMPATIBLE WITH 300 NARROWLINE.

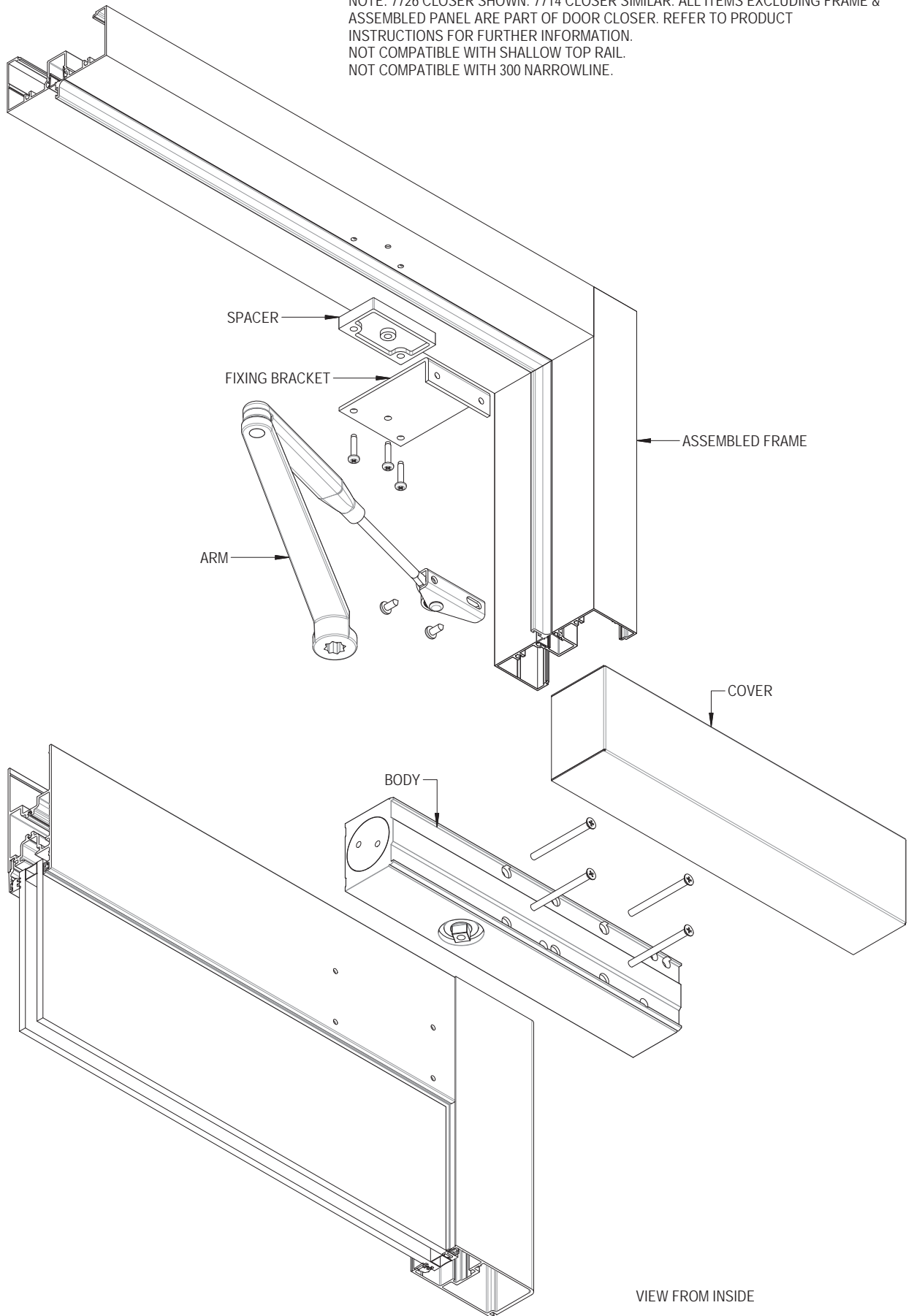

Please read in conjunction with Important Conditions – Index (also available on Capral website)

Assembly - Open Out Slide Track Closer

Not To Scale

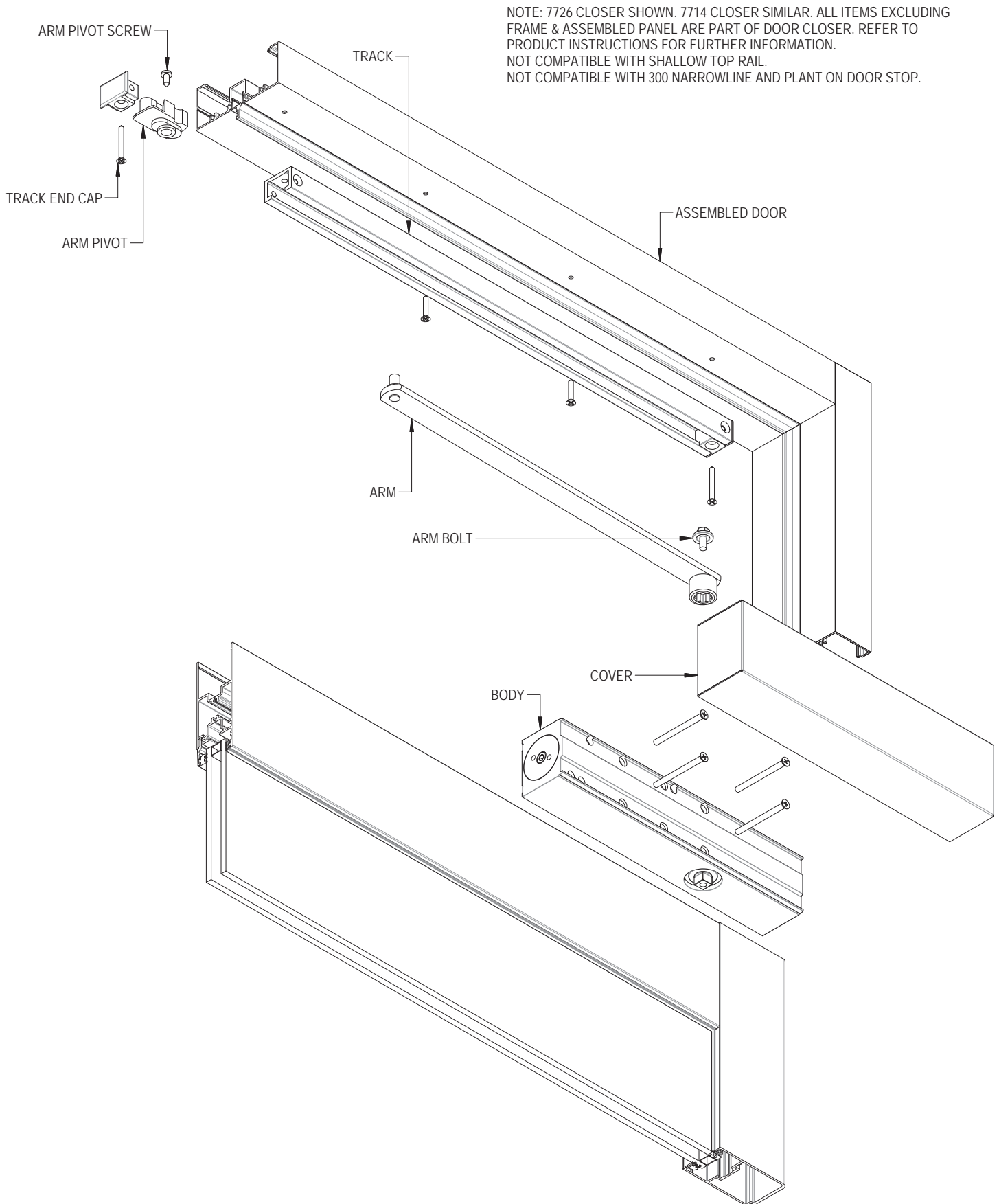

NOTE: 7726 CLOSER SHOWN. 7714 CLOSER SIMILAR. ALL ITEMS EXCLUDING FRAME & ASSEMBLED PANEL ARE PART OF DOOR CLOSER. REFER TO PRODUCT INSTRUCTIONS FOR FURTHER INFORMATION.
 NOT COMPATIBLE WITH SHALLOW TOP RAIL.
 NOT COMPATIBLE WITH 300 NARROWLINE AND PLANT ON DOOR STOP.

Please read in conjunction with Important Conditions – Index (also available on Capral website)

Assembly - Open In Door Closers

Not To Scale

NOTE: 7726 CLOSER SHOWN, 7714 CLOSER SIMILAR.
ALL ITEMS EXCLUDING FRAME & ASSEMBLED PANEL ARE PART OF DOOR CLOSER. REFER TO PRODUCT INSTRUCTIONS FOR FURTHER INFORMATION.

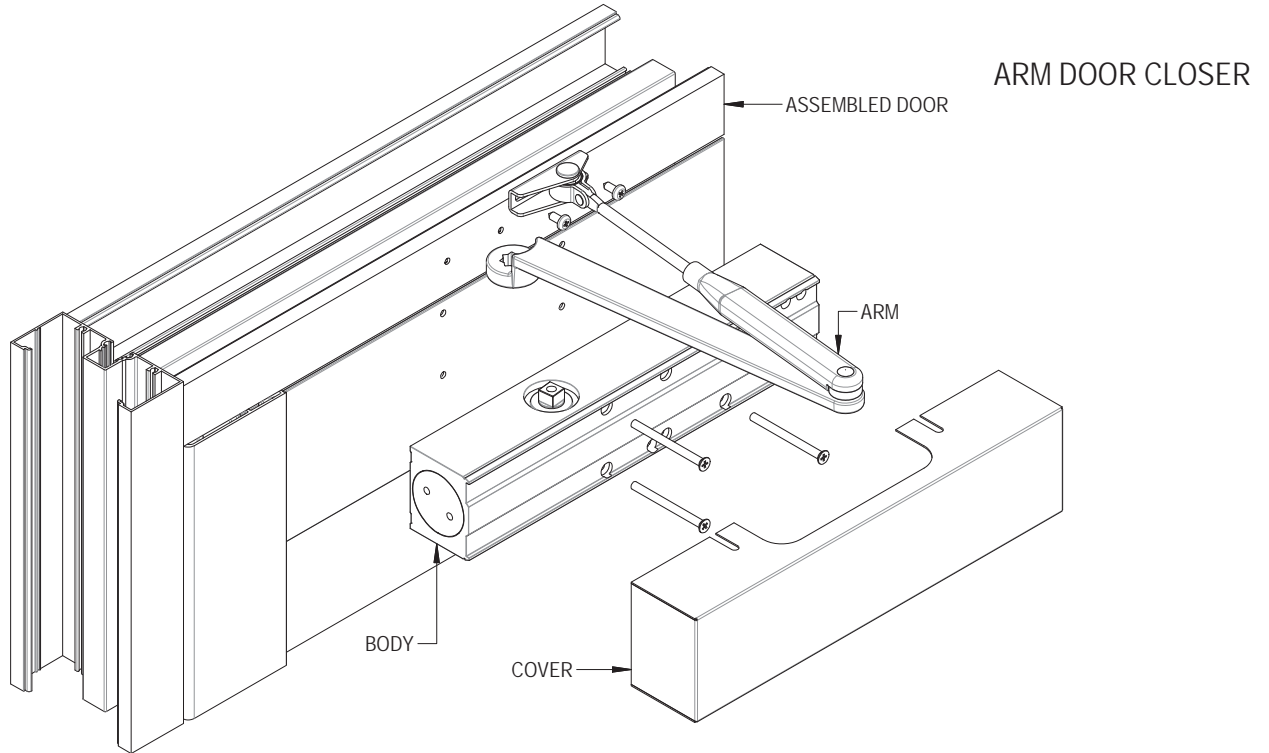

SLIDE TRACK DOOR CLOSER

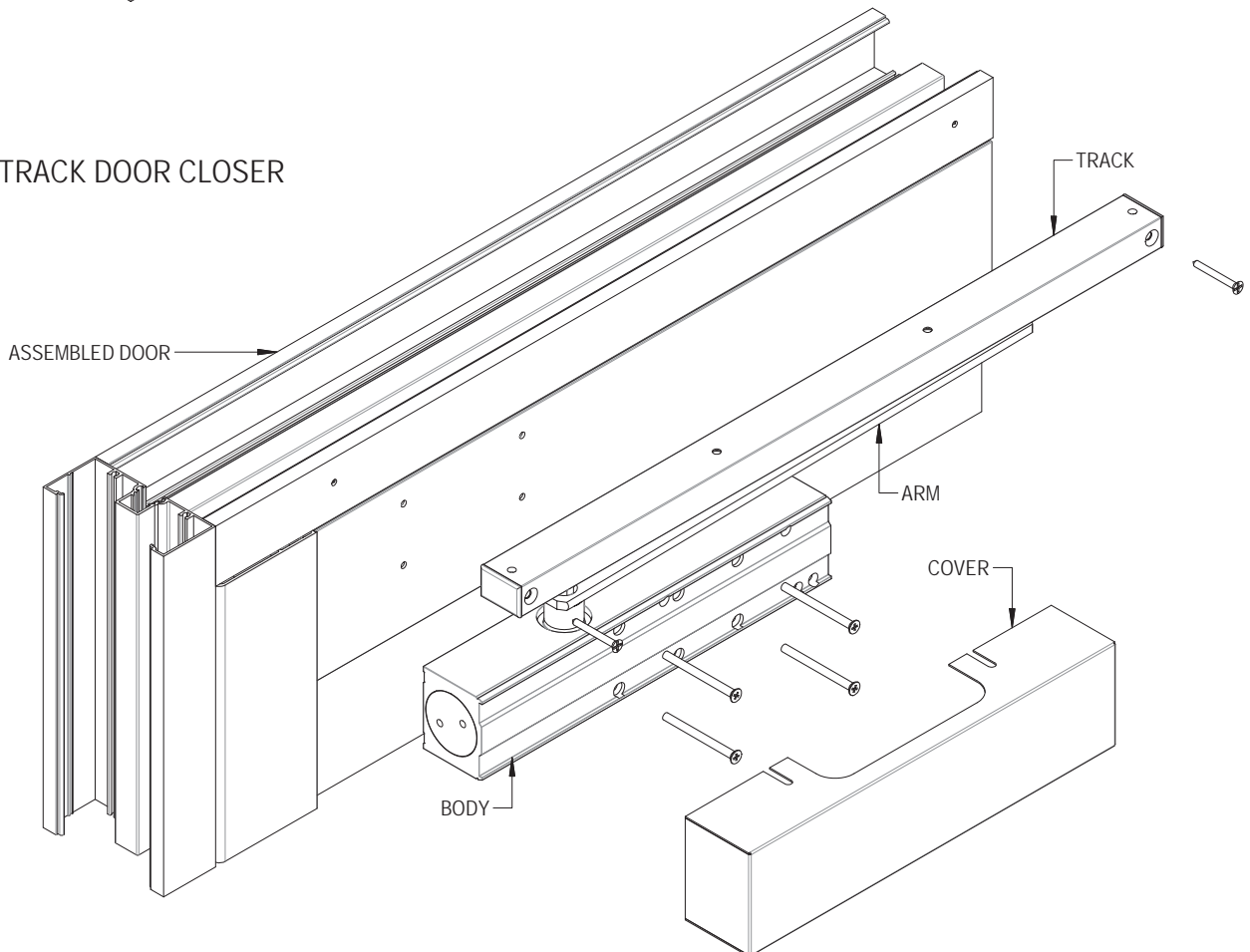

Please read in conjunction with Important Conditions – Index (also available on Capral website)

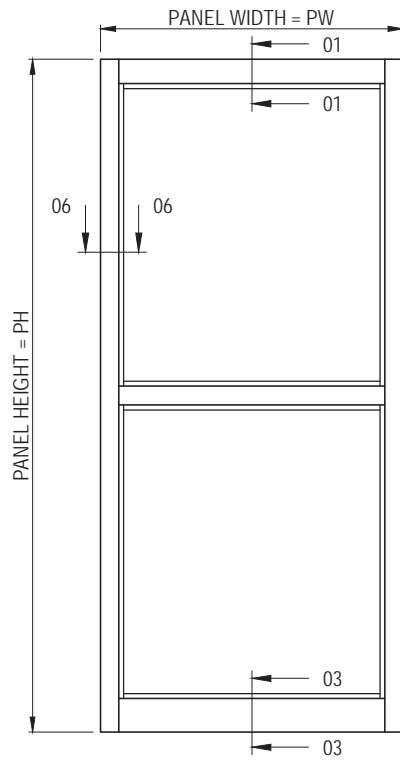

SINGLE HINGED, PIVOT OR SLIDING (X)

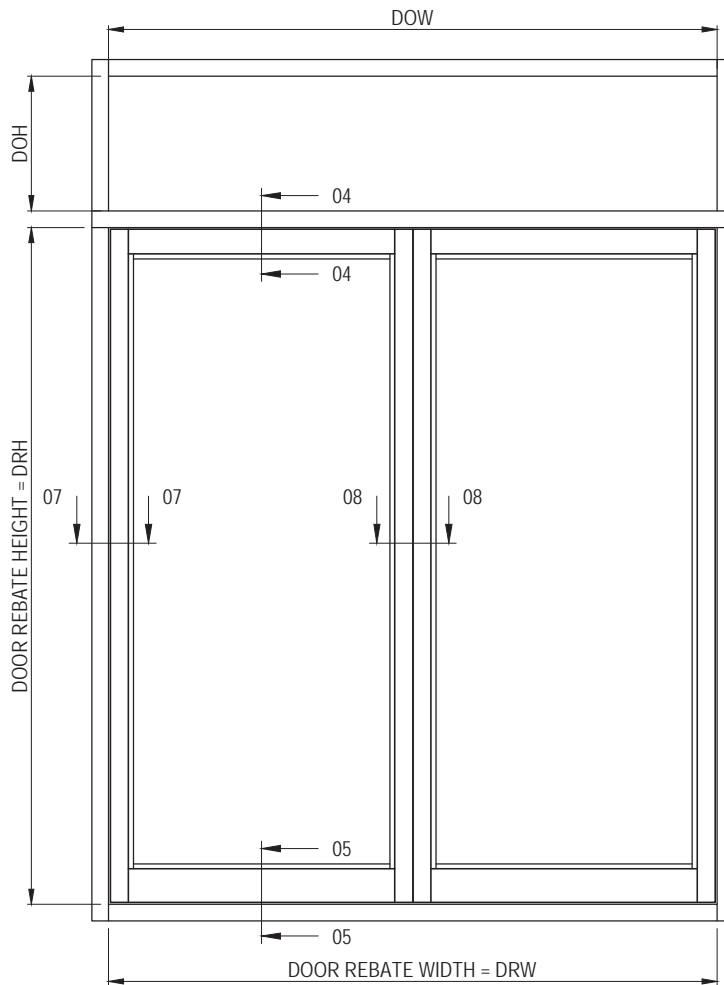

DOUBLE HINGED, PIVOT OR SLIDING (XO, XX)

Please read in conjunction with Important Conditions – Index (also available on Capral website)

Arrangement - Euro Bracket / Jacking Screw Glazing Panel

Scale 1:2

NOTE: ALT. USE EURO BRACKETS WITH BLOCK GLAZING
SG SHOWN AS EXAMPLE, TG & DG SIMILAR

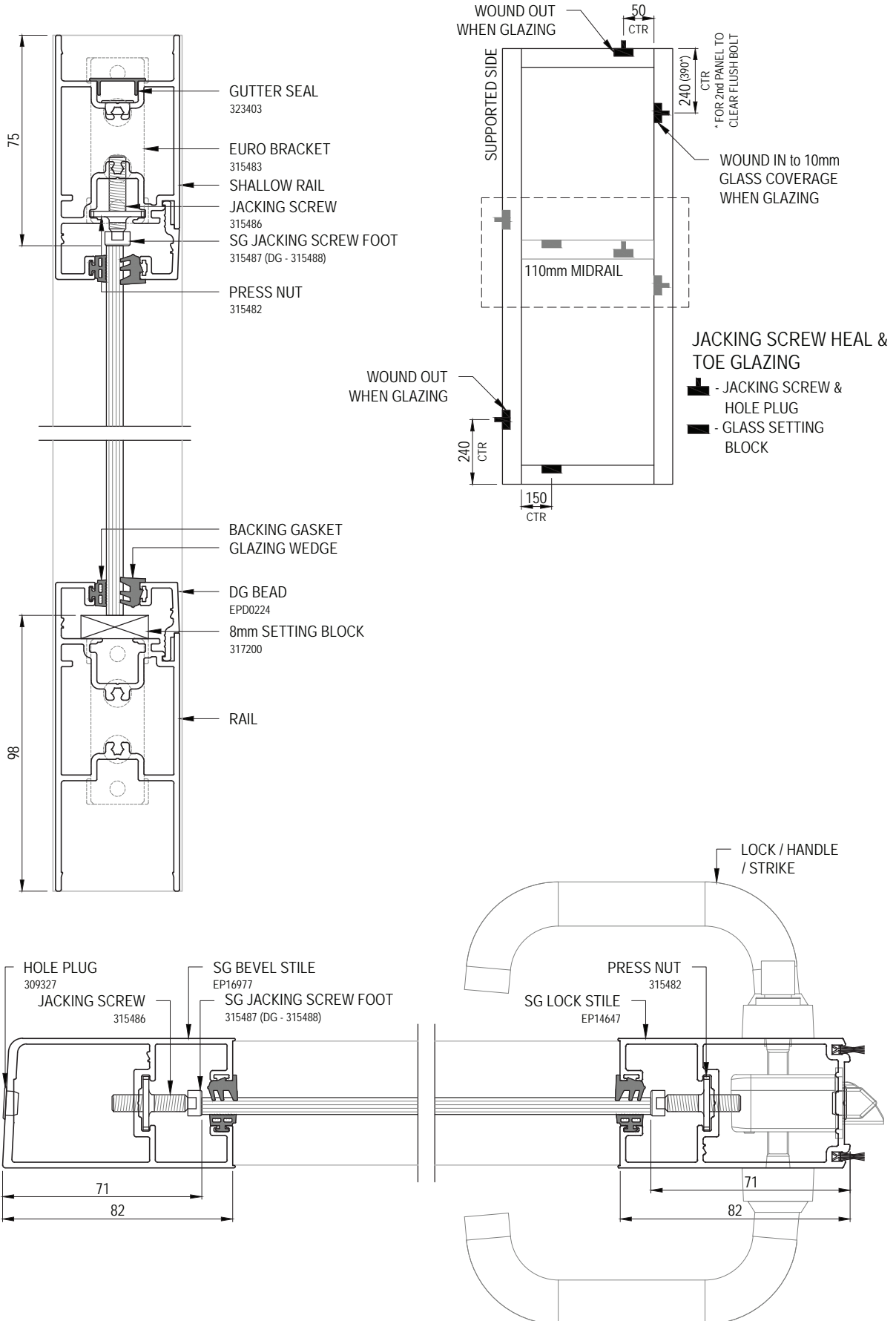

Please read in conjunction with Important Conditions – Index (also available on Capral website)

Arrangement - Spigot / Block Glazing Panel

Scale 1:2

NOTE: ALT. USE SPIGOTS WITH JACKING SCREW GLAZING
 DG SHOWN AS EXAMPLE, SG & TG SIMILAR

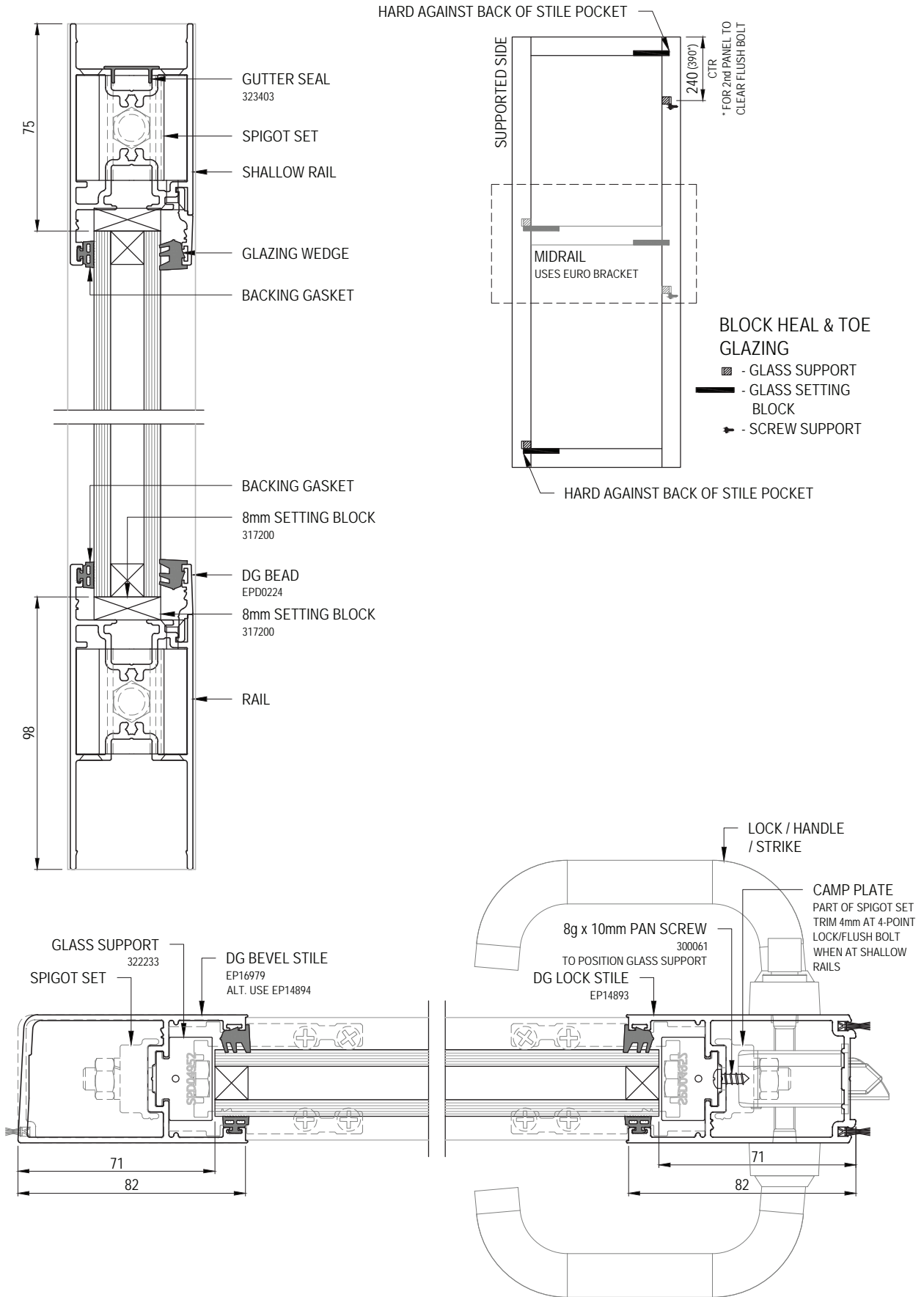

Please read in conjunction with Important Conditions – Index (also available on Capral website)

Arrangement - Tie Rod / Block Glazing Panel

Scale 1:2

NOTE: MUST BE USED WITH BLOCK GLAZING GLAZING
DG SHOWN AS EXAMPLE, SG & TG SIMILAR

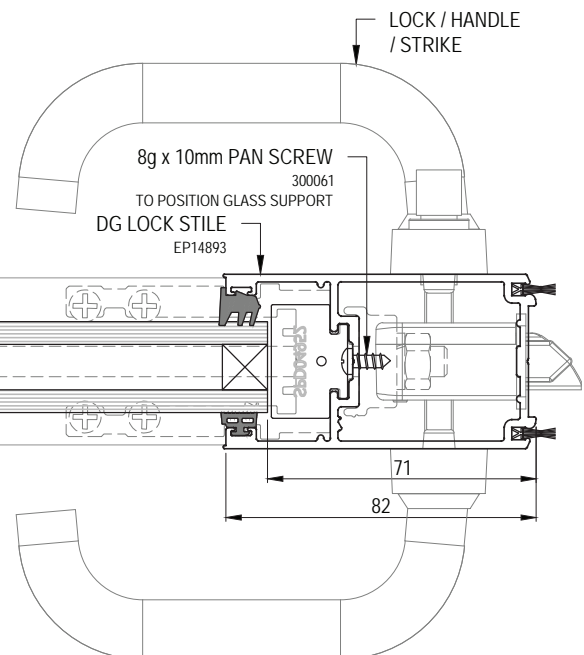
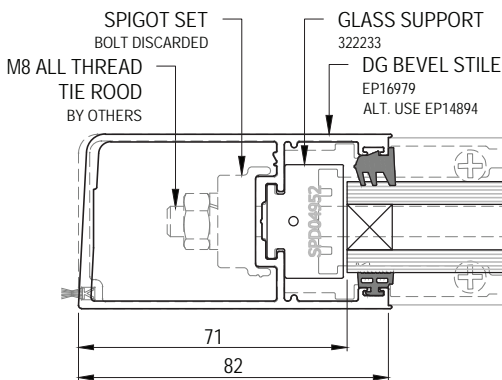
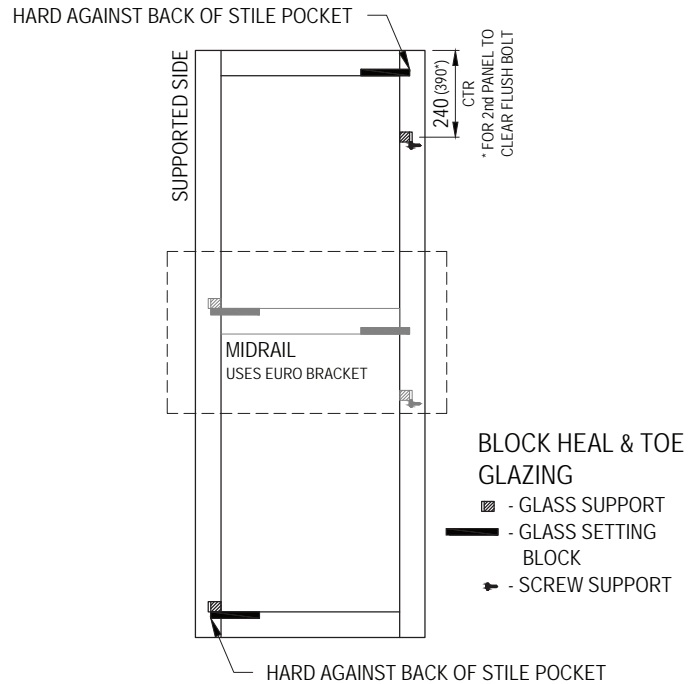
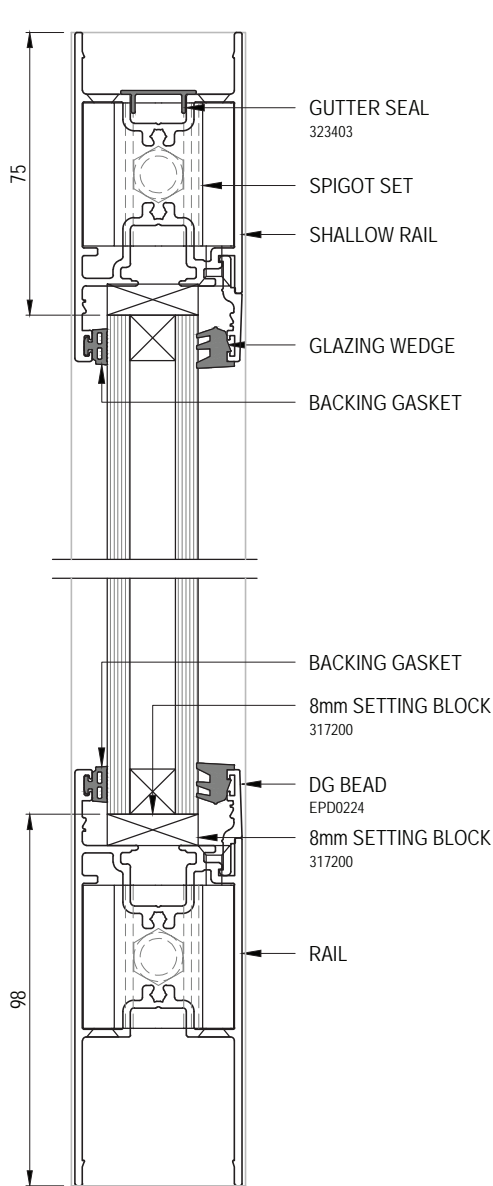

Please read in conjunction with Important Conditions – Index (also available on Capral website)

Arrangement - Midrails

Scale 1:2

NOTE: LOCKS MUST BE POSITIONED CLEAR OF 50mm MIDRAIL BRACKET
 EURO BRACKET MUST BE USED WITH MIDRAILS (EXCLUDING 50mm MIDRAIL)
 JACKING SCREW GLAZING CAN ONLY BE USED ON 110mm MIDRAIL

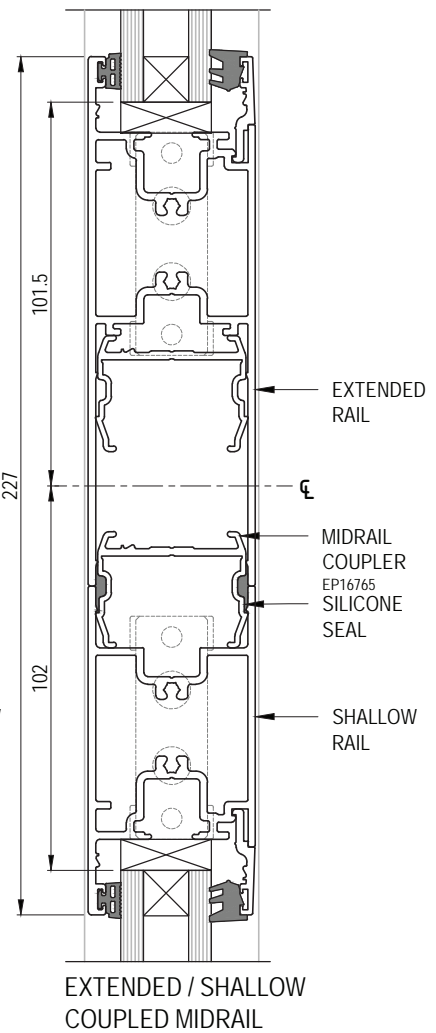
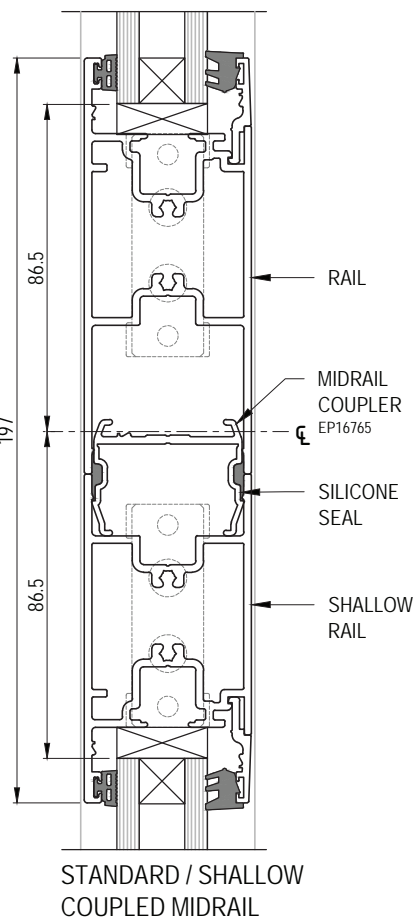
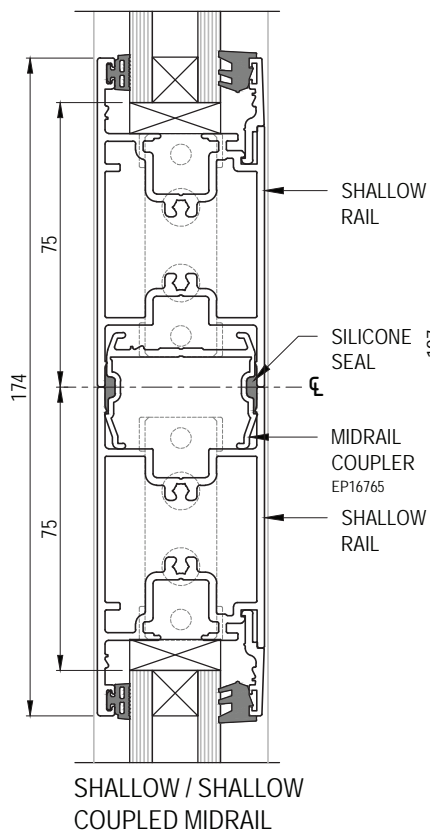
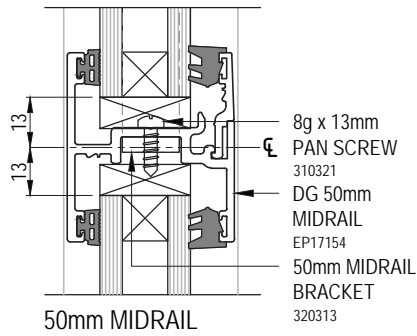
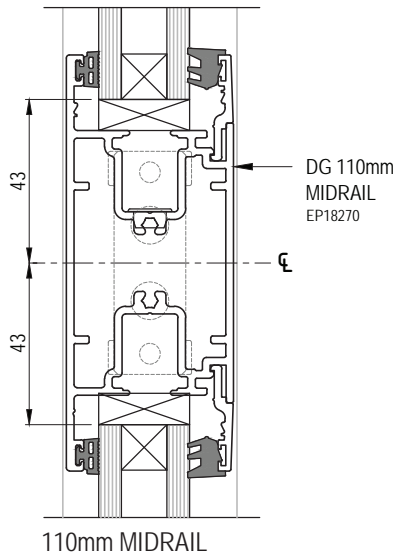

Please read in conjunction with Important Conditions – Index (also available on Capral website)

Arrangement - Midrails

Scale 1:2

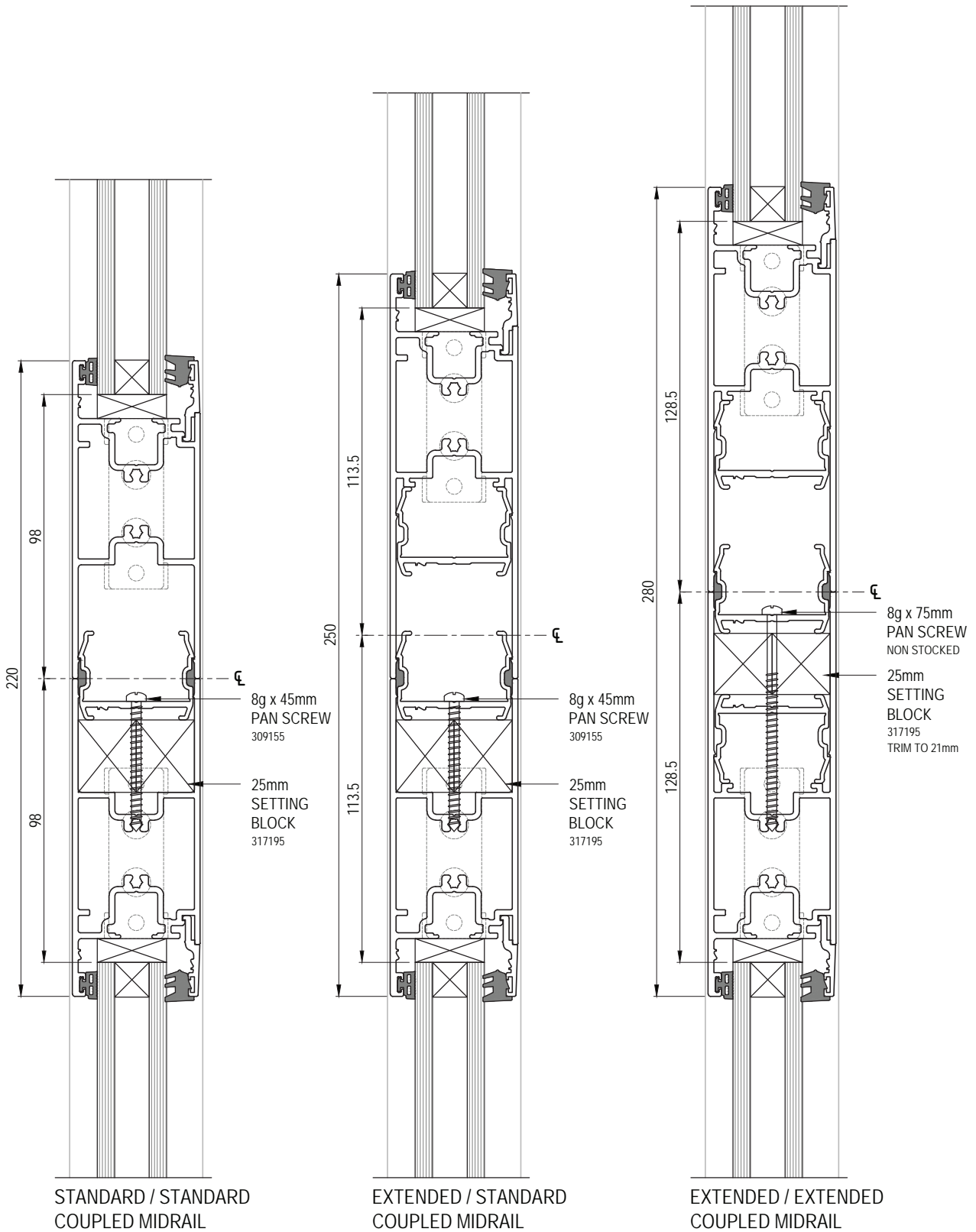

Please read in conjunction with Important Conditions – Index (also available on Capral website)

Arrangement - Louvre Panel

Scale 1:2

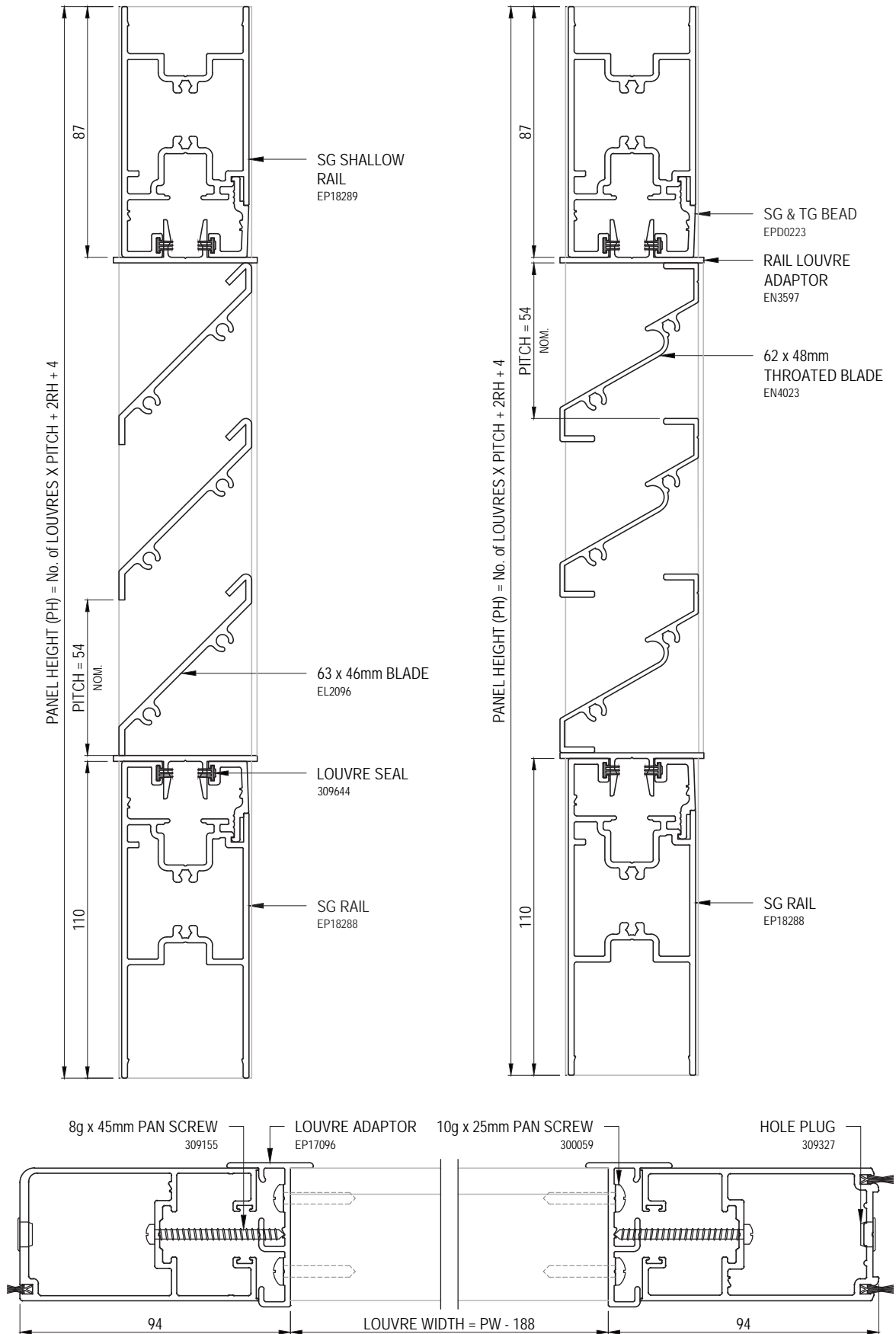

Please read in conjunction with Important Conditions – Index (also available on Capral website)

Arrangement - Slatted Panel

Scale 1:2

NOTE: BELOW FORMULA HEIGHT ARE BASED ON SLAT HEIGHTS. FOR SH BASED ON PANEL HEIGHT REFER TO SEC4
 HEAL & TOE GLAZING METHOD NOT SHOWN FOR CLARITY, EITHER JACKING SCREW OR BLOCK GLAZING IS APPLICABLE.
 TIP - 19 QTY SLATS WITH STANDARD RAILS = 2100mm PANEL HEIGHT WITH 100mm SLATS OR 1948mm WITH 92mm SLATS

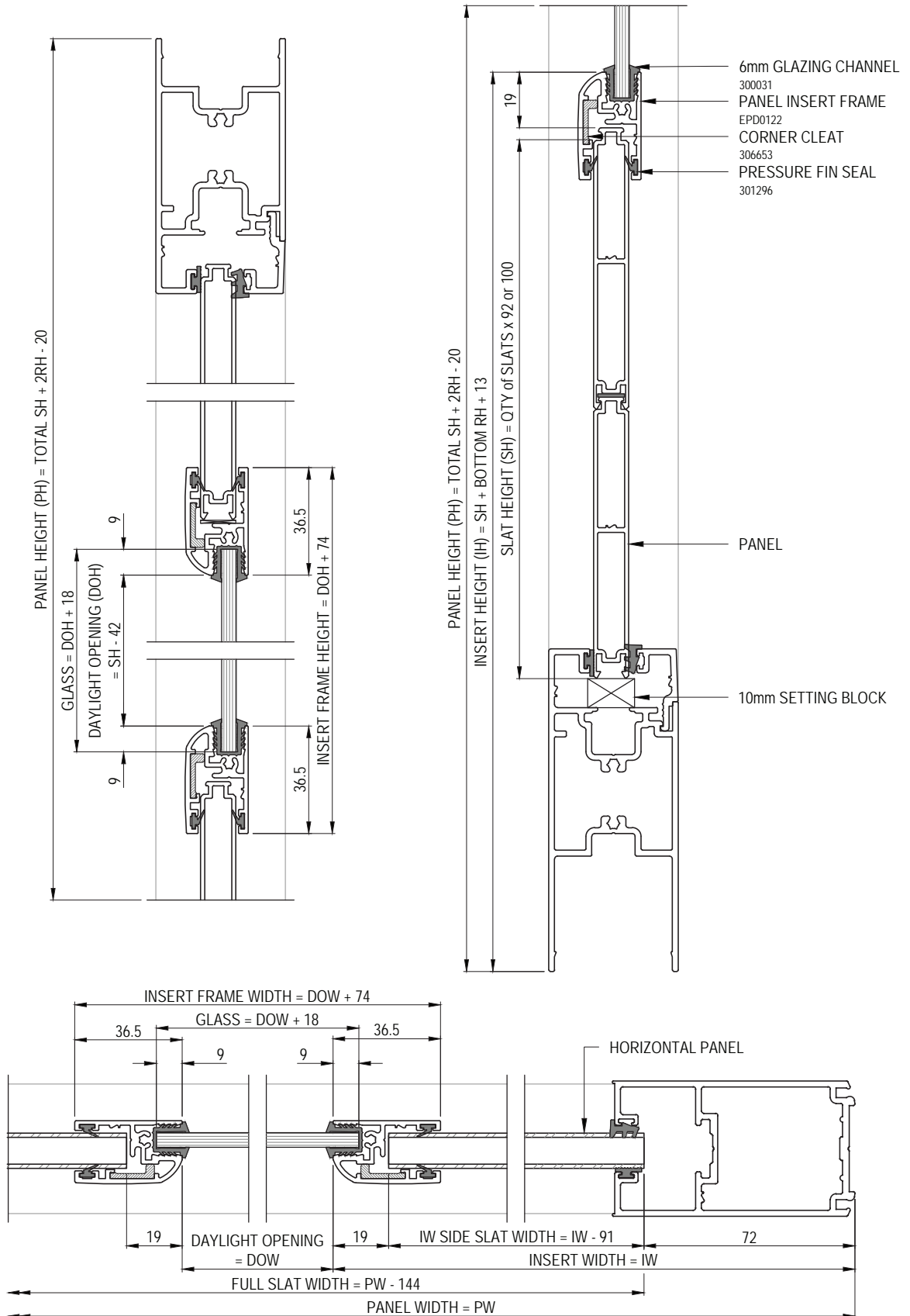

Please read in conjunction with Important Conditions – Index (also available on Capral website)

Vertical Arrangement 01 & 03 - 76mm Open Out Hinged Door

Scale 1:2

NOTE: 300 NARROWLINE HEAD AND SG SHOWN AS EXAMPLE OTHER FRAMES, TG & DG SIMILAR
 PANEL ASSEMBLY & GLAZING METHOD NOT SHOWN FOR CLARITY

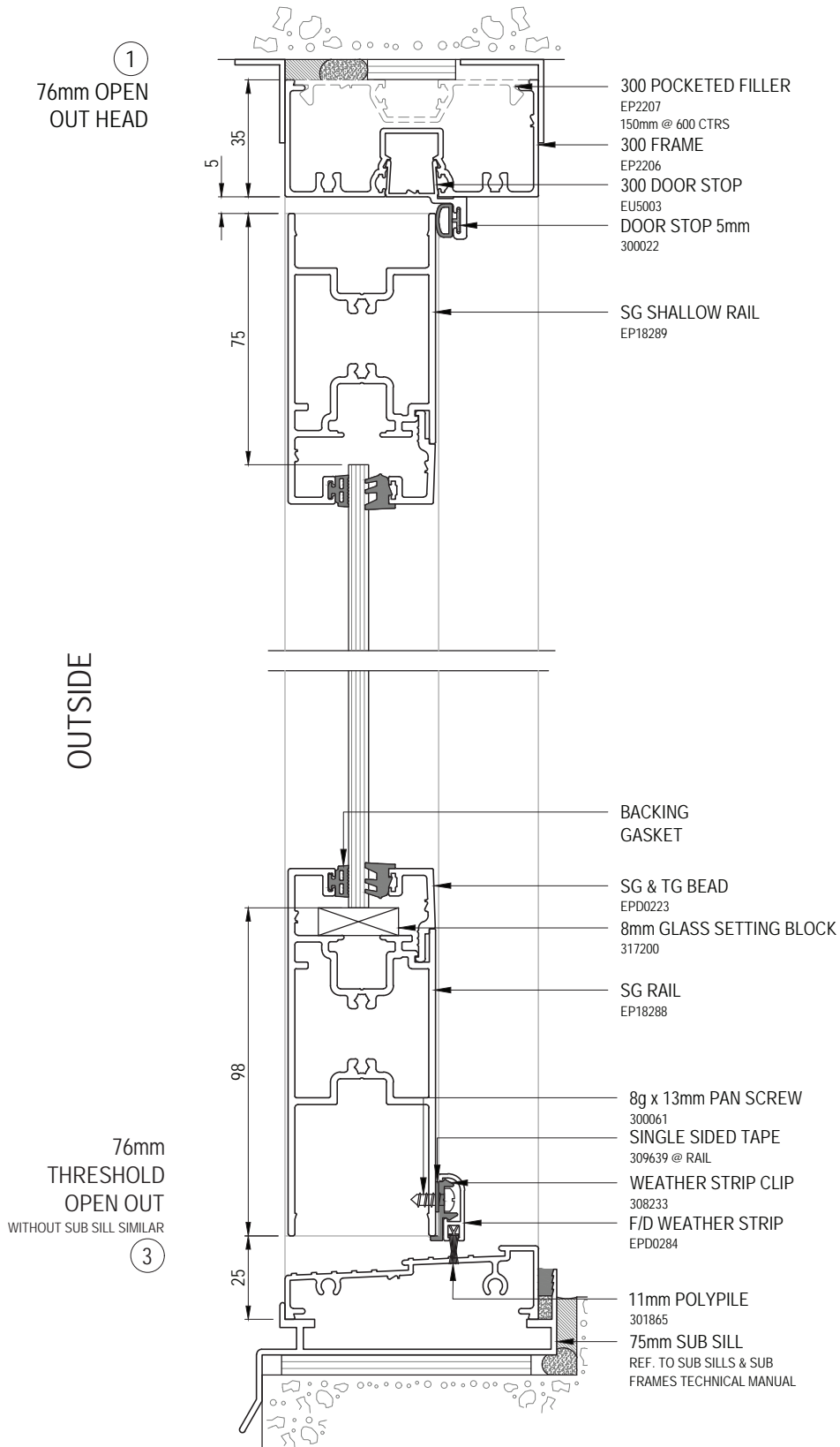

Please read in conjunction with Important Conditions – Index (also available on Capral website)

Vertical Arrangement 01 & 03 - 76mm Open In Hinged Door

Scale 1:2

NOTE: 300 NARROWLINE HEAD AND SG SHOWN AS EXAMPLE OTHER FRAMES, TG & DG SIMILAR
 PANEL ASSEMBLY & GLAZING METHOD NOT SHOWN FOR CLARITY

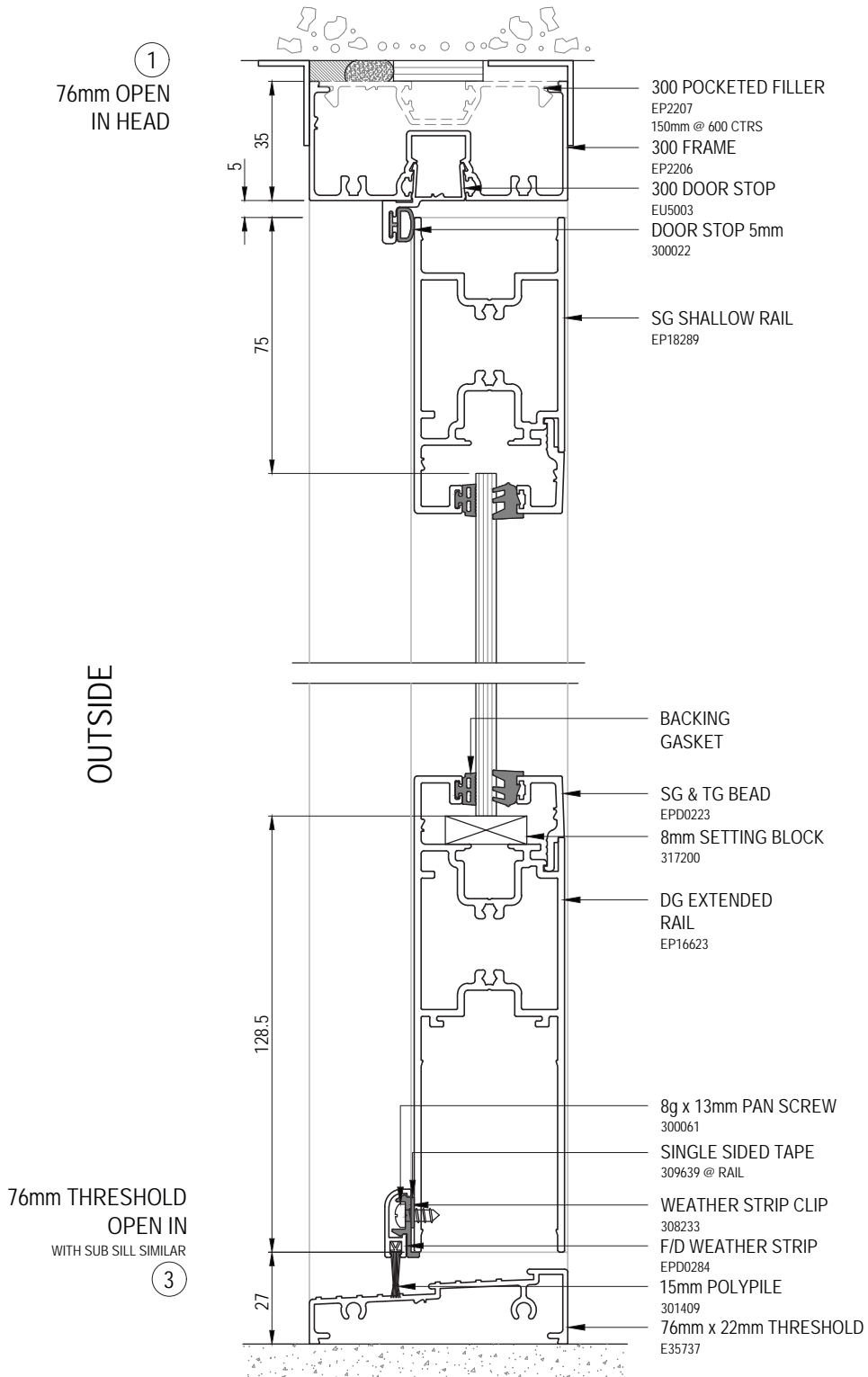

Please read in conjunction with Important Conditions – Index (also available on Capral website)

Vertical Arrangement 01 & 03 - 101.6mm Open Out Hinged Door

Scale 1:2

NOTE: 400 NARROWLINE HEAD AND DG SHOWN AS EXAMPLE OTHER FRAMES, SG & TG SIMILAR
 PANEL ASSEMBLY & GLAZING METHOD NOT SHOWN FOR CLARITY

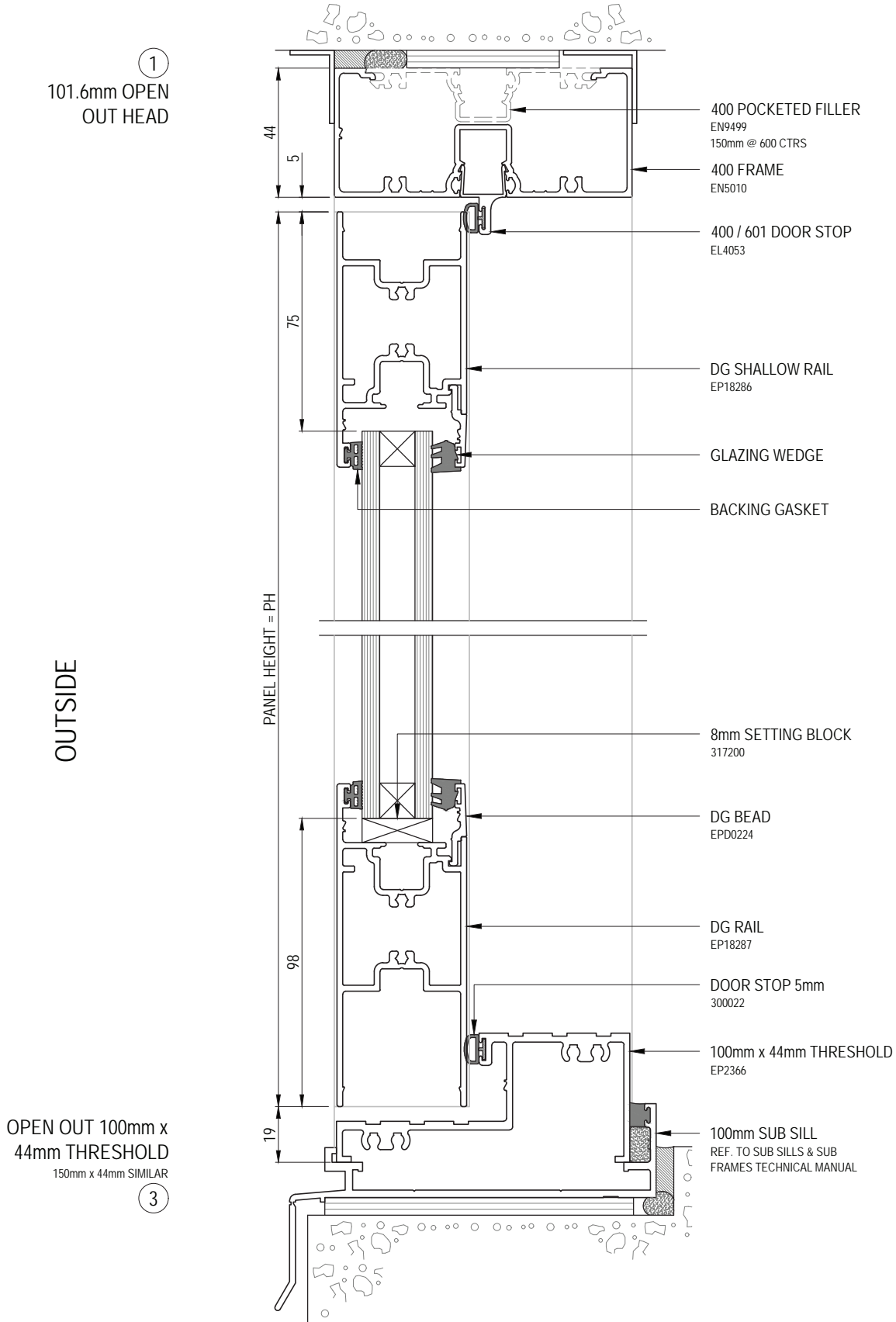

Please read in conjunction with Important Conditions – Index (also available on Capral website)

Vertical Arrangement 01 & 03 - 101.6mm Open In Hinged Door

Scale 1:2

NOTE: 400 NARROWLINE HEAD AND TG SHOWN AS EXAMPLE OTHER FRAMES, SG & DG SIMILAR
 PANEL ASSEMBLY & GLAZING METHOD NOT SHOWN FOR CLARITY

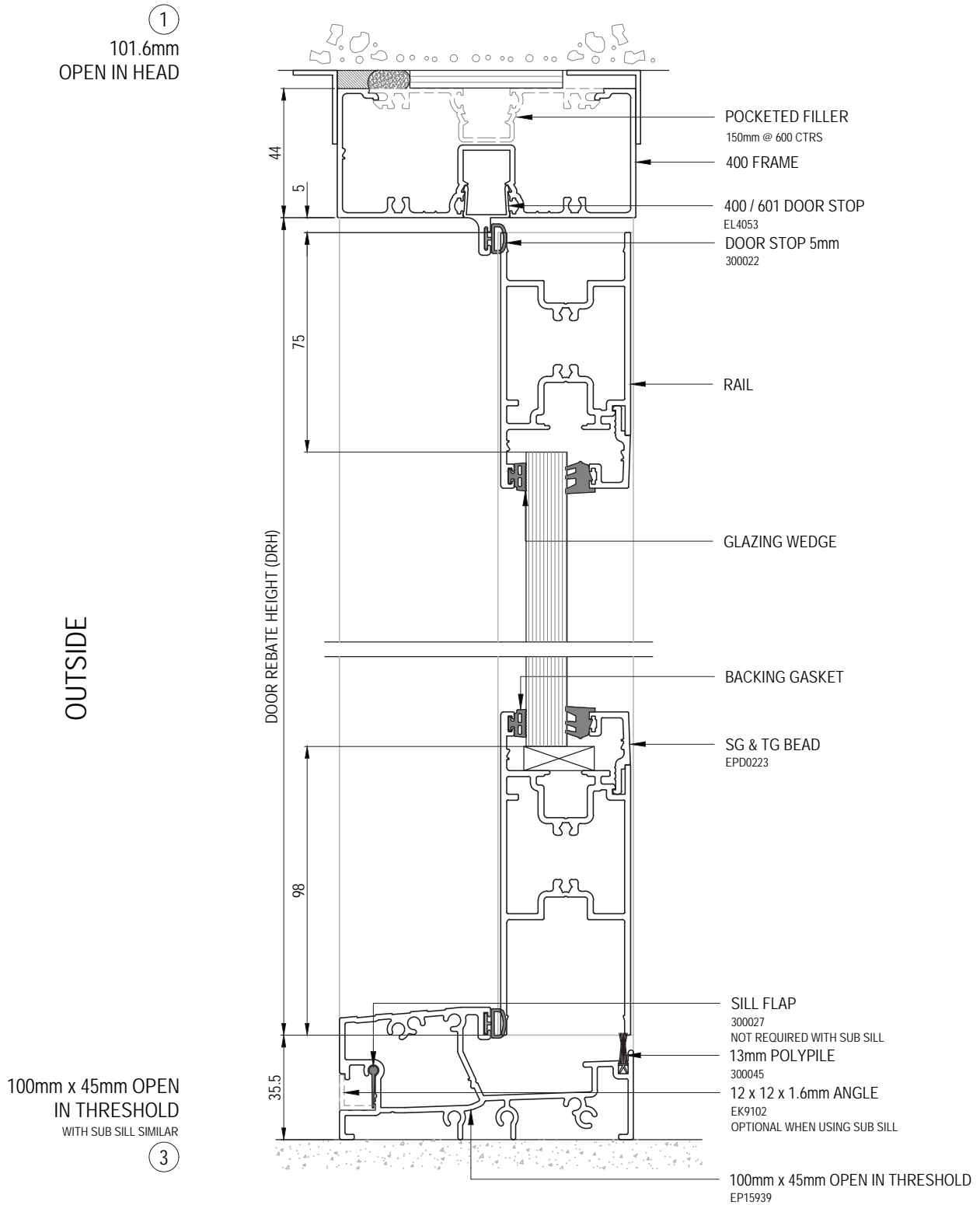

Please read in conjunction with Important Conditions – Index (also available on Capral website)

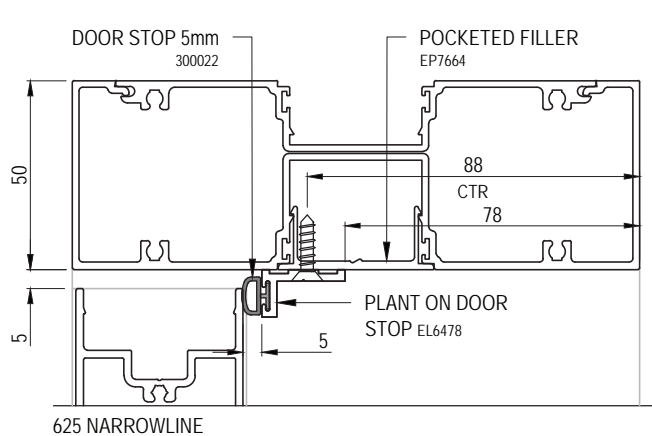
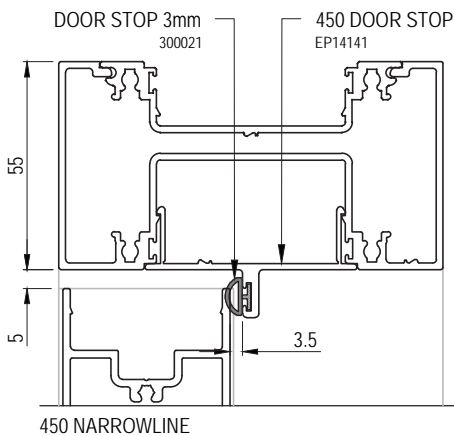
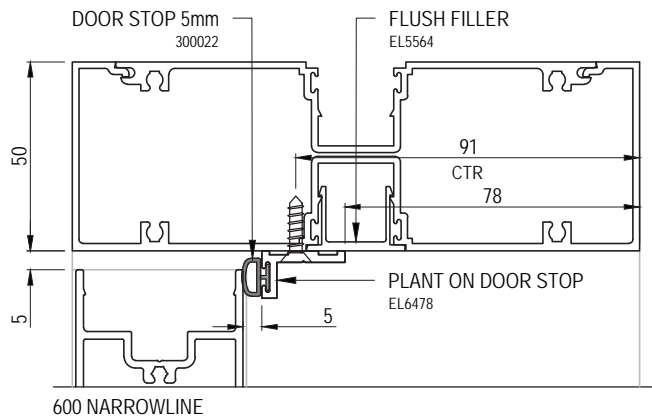
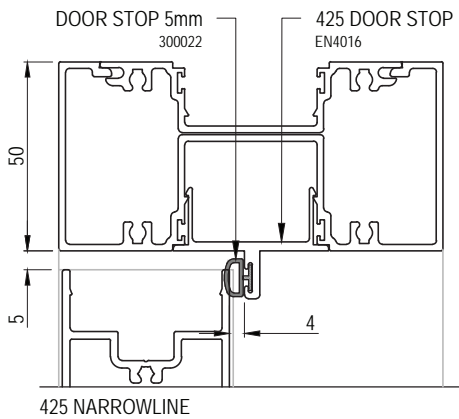
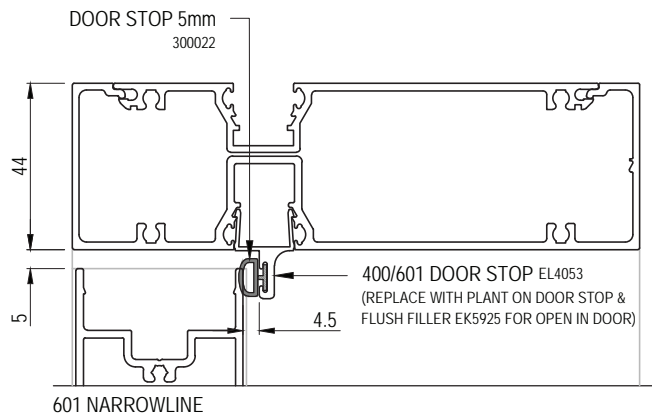
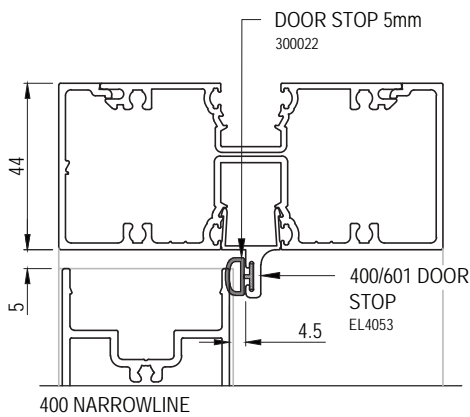
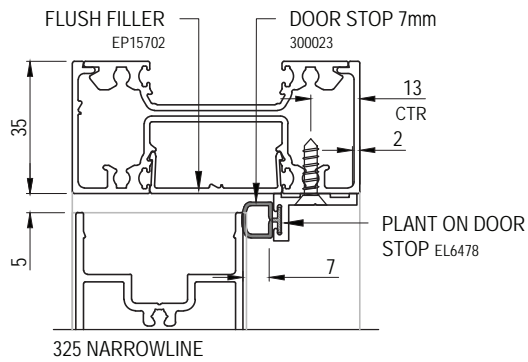
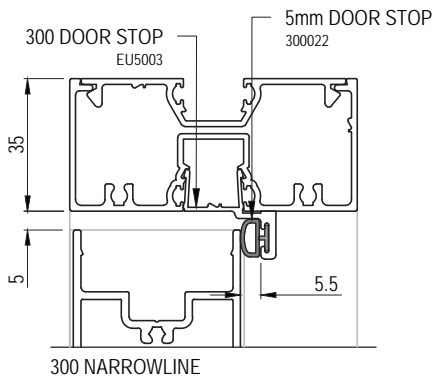

Please read in conjunction with Important Conditions – Index (also available on Capral website)

Vertical Arrangement 01 - Alt. Flushline Hinged Door Frames

Scale 1:2

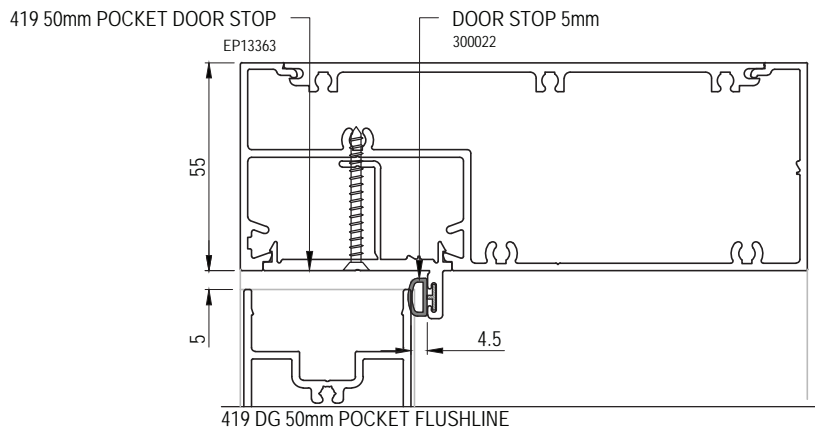
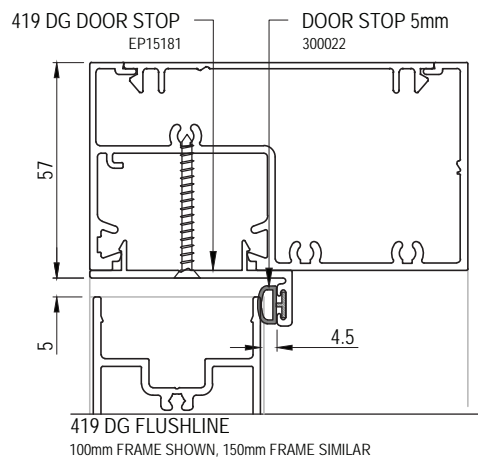
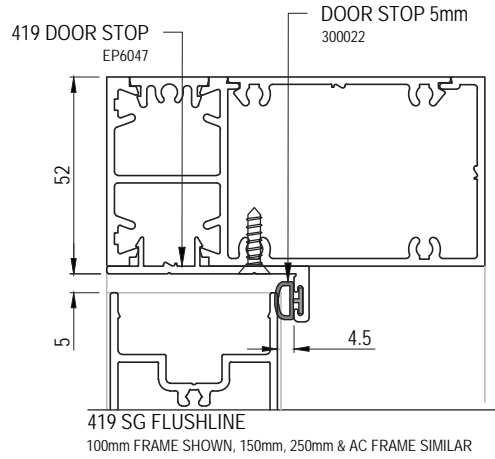

Please read in conjunction with Important Conditions – Index (also available on Capral website)

Vertical Arrangement 03 - Alt. Open Out Hinged Door Sills

Scale 1:2

NOTE: ONLY THE 100mm & 150mm RAMPED THRESHOLDS AND NO THRESHOLD ARE AS1428 - DESIGN FOR ACCESS & MOBILITY COMPLIANT

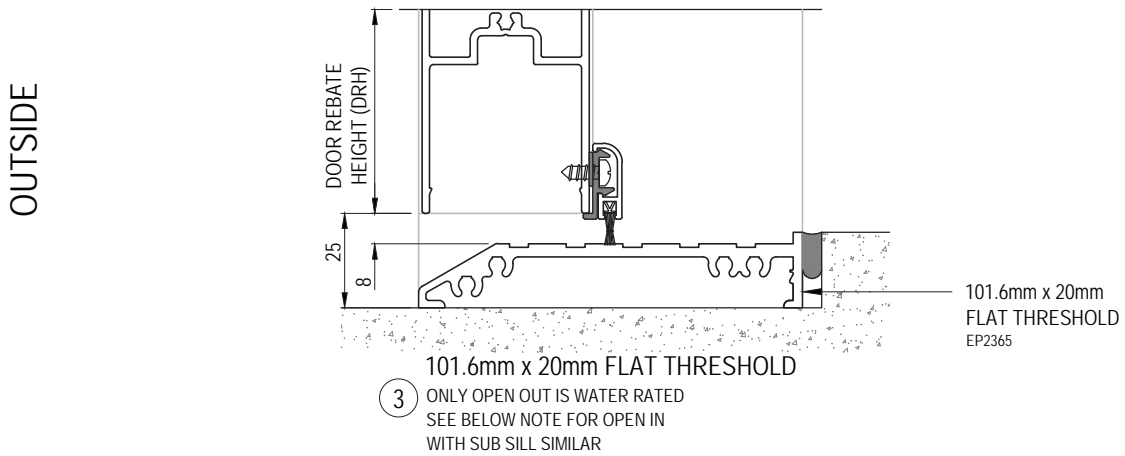
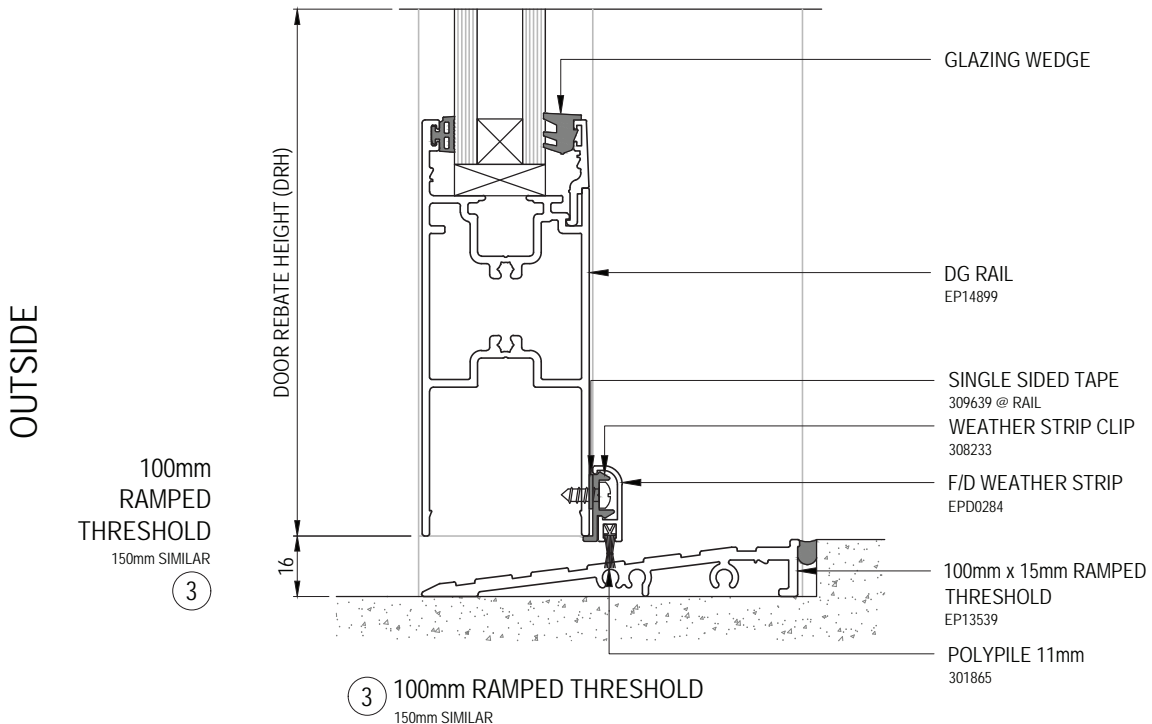

IMPORTANT NOTE: THIS PRODUCT WHEN FABRICATED WITH THE BELOW THRESHOLDS ARE NOT WATER RATED AND DO NOT CONFORM TO AUSTRALIAN STANDARD AS2047 AND ARE INTENDED FOR INTERNAL APPLICATIONS ONLY OR WHERE THE BUILDER MAKES ALLOWANCES TO ADEQUATELY SHELTER THE PRODUCT.

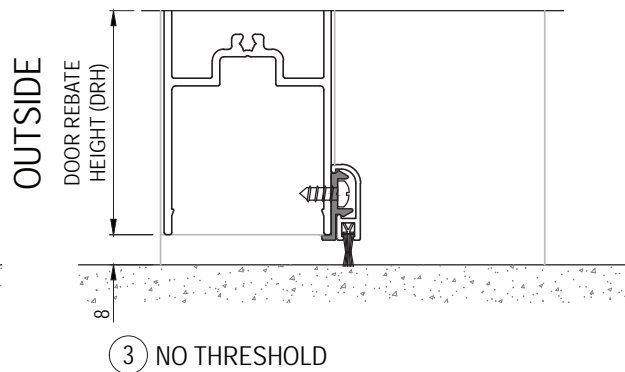
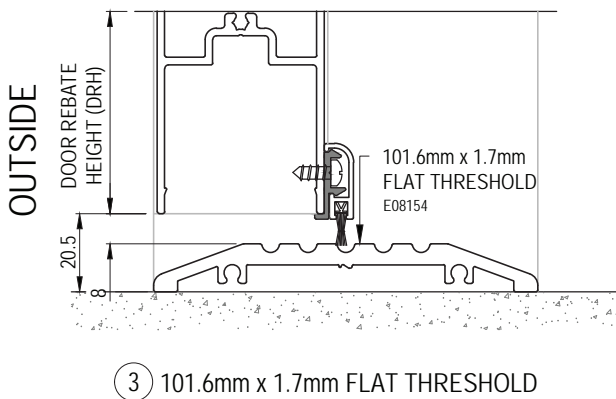

Please read in conjunction with Important Conditions – Index (also available on Capral website)

Vertical Arrangement 03 - Alt. Open In Hinged Door Sills

Scale 1:2

NOTE: ONLY THE 100mm & 150mm RAMPED THRESHOLDS AND NO THRESHOLD ARE AS1428 - DESIGN FOR ACCESS & MOBILITY COMPLIANT

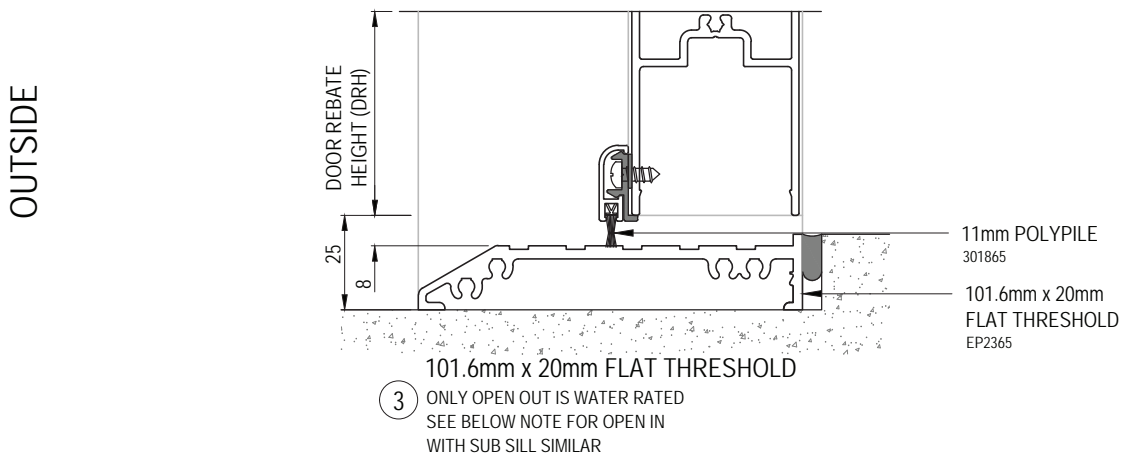
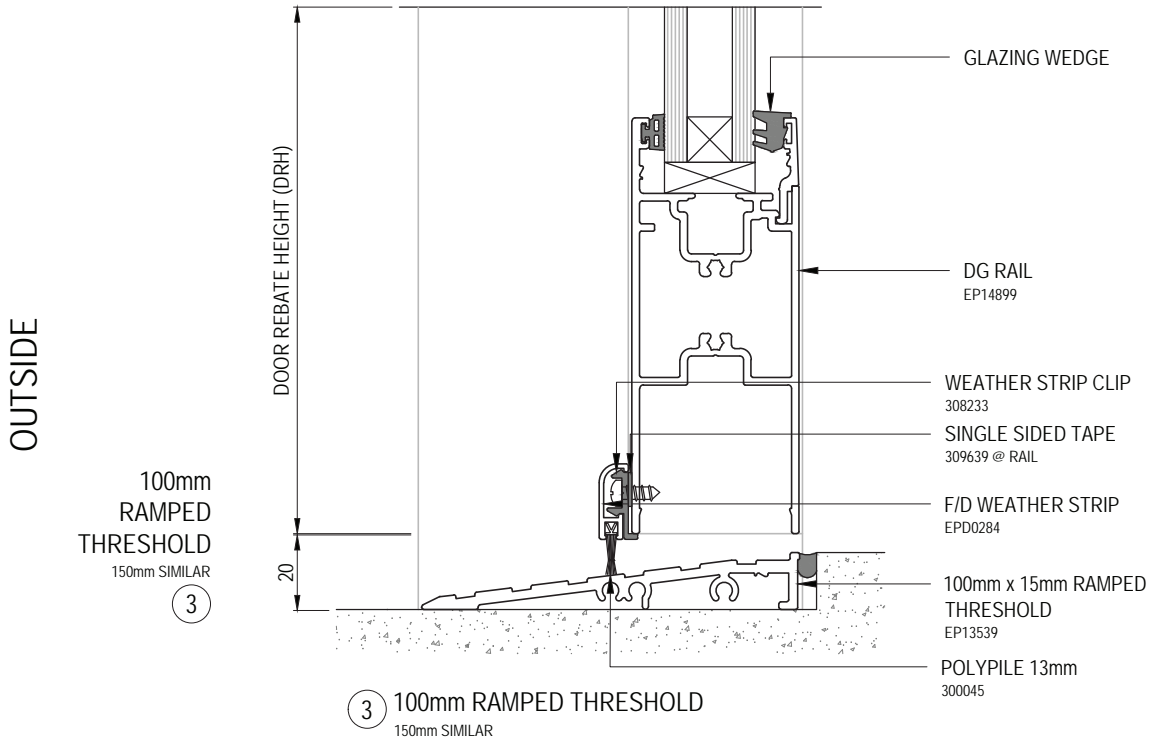

IMPORTANT NOTE: THIS PRODUCT WHEN FABRICATED WITH THE BELOW THRESHOLDS ARE NOT WATER RATED AND DO NOT CONFORM TO AUSTRALIAN STANDARD AS2047 AND ARE INTENDED FOR INTERNAL APPLICATIONS ONLY OR WHERE THE BUILDER MAKES ALLOWANCES TO ADEQUATELY SHELTER THE PRODUCT.

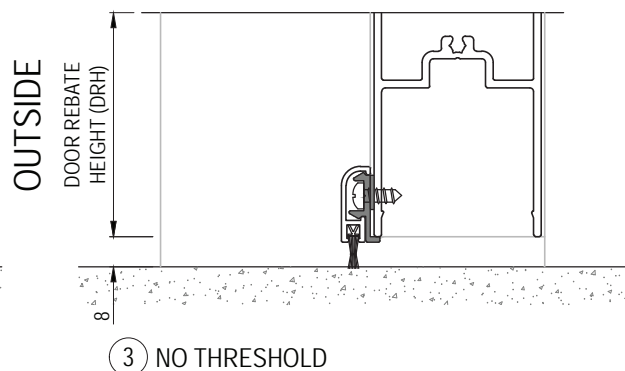
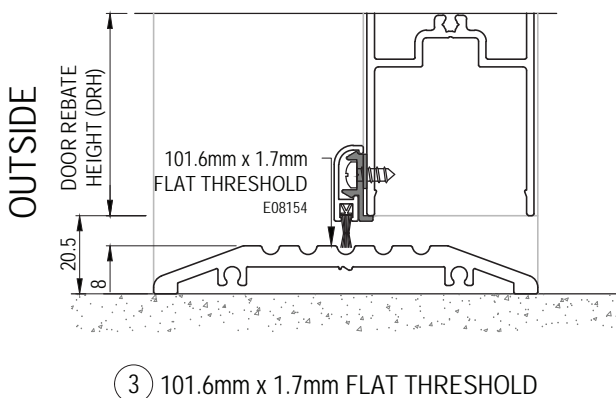

Please read in conjunction with Important Conditions – Index (also available on Capral website)

Horizontal Arrangement 06 & 07 - Open Out Hinged Door

Scale 1:2

NOTE: SG STANDARD STILES SHOWN AS EXAMPLE, DG, TG & WIDE STILES SIMILAR
 400 NARROWLINE FRAME SHOWN AS EXAMPLE, REFER TO ALT. HEADS FOR OTHER FRAMES
 PANEL ASSEMBLY & GLAZING METHOD NOT SHOWN FOR CLARITY

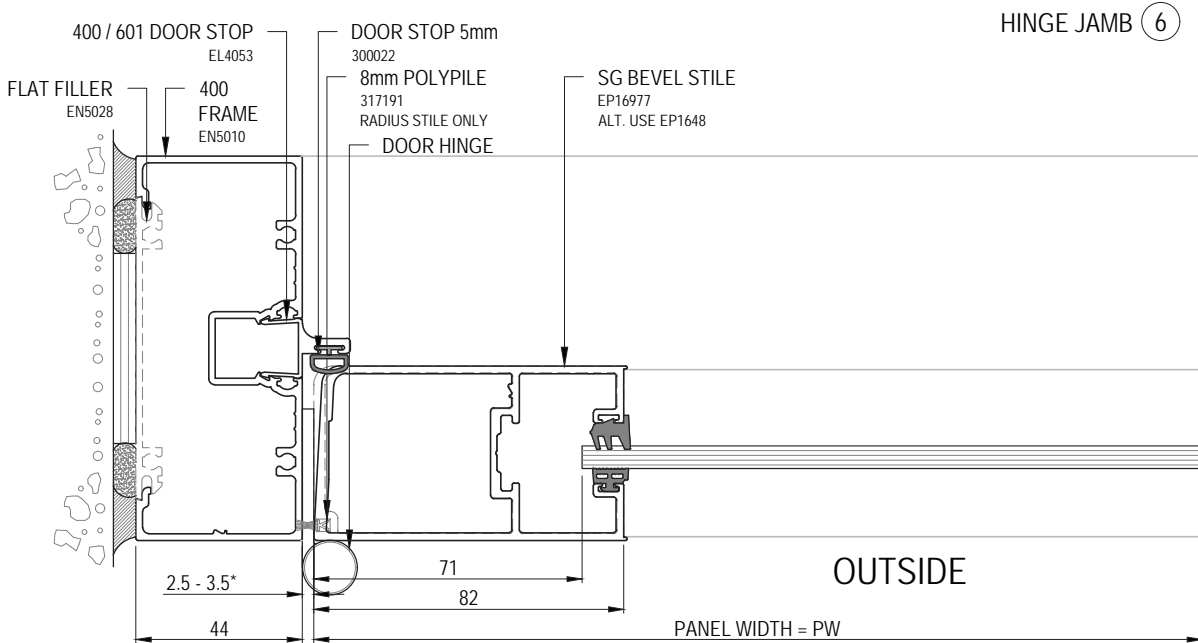

* HINGE THICKNESSES VARY.
 REFER TO Sec4 FORMULAS.

7 LOCK JAMB

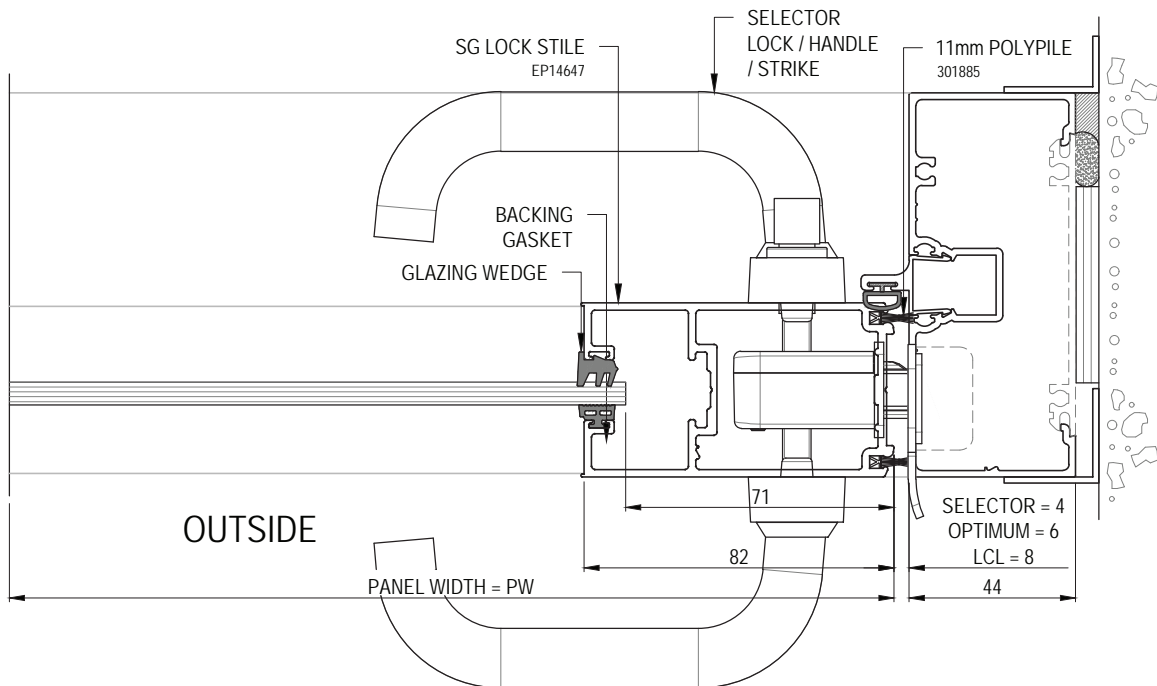

Please read in conjunction with Important Conditions – Index (also available on Capral website)

Horizontal Arrangement 06 & 07 - Open In Hinged Door

Scale 1:2

NOTE: DG WIDE STILES SHOWN AS EXAMPLE, SG, TG & STANDARD STILES SIMILAR
 400 NARROWLINE FRAME SHOWN AS EXAMPLE, REFER TO ALT. HEADS FOR OTHER FRAMES
 PANEL ASSEMBLY & GLAZING METHOD NOT SHOWN FOR CLARITY

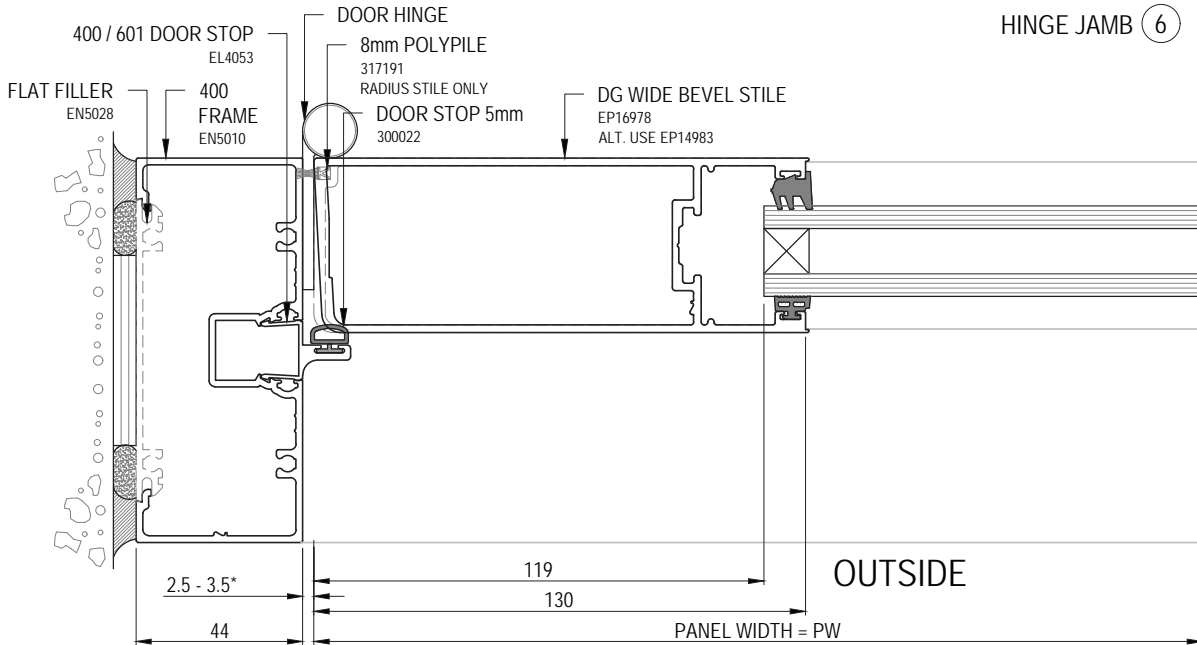

* HINGE THICKNESSES VARY.
 REFER TO Sec4 FORMULAS.

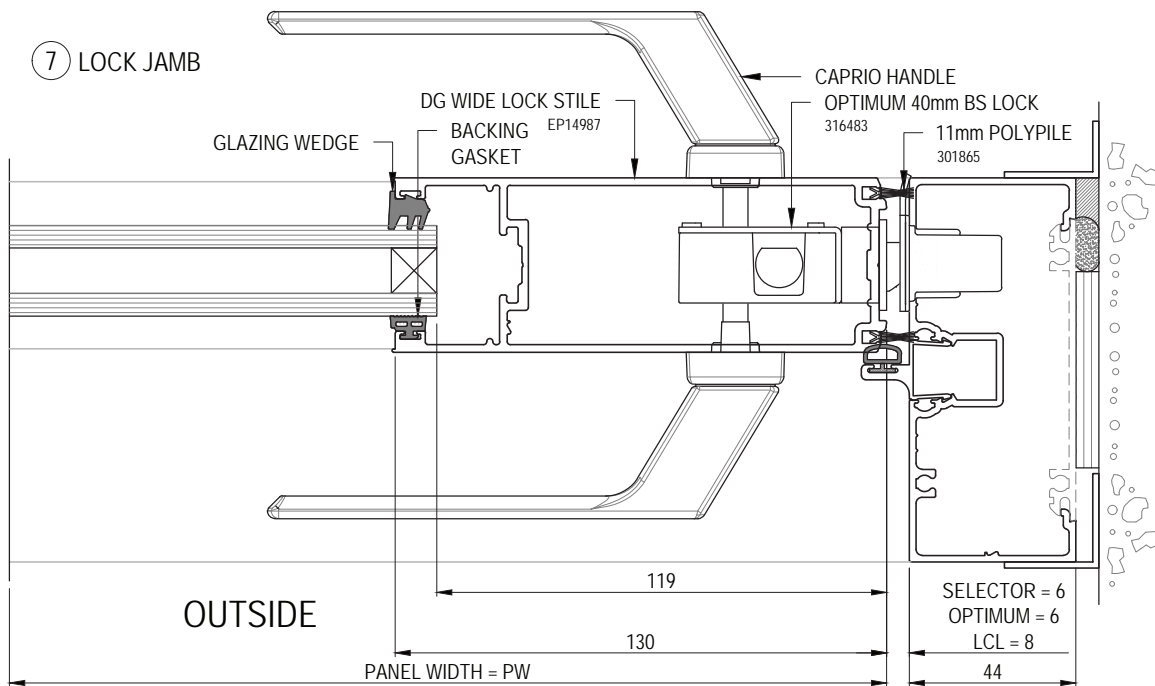

Please read in conjunction with Important Conditions - Index (also available on Capral website)

Horizontal Arrangement 08 - Double Hinged Door Meeting Stiles

Scale 1:2

NOTE: COMBINATIONS SHOWN AS EXAMPLE, OTHERS SIMILAR
 PANEL ASSEMBLY & GLAZING METHOD NOT SHOWN FOR CLARITY

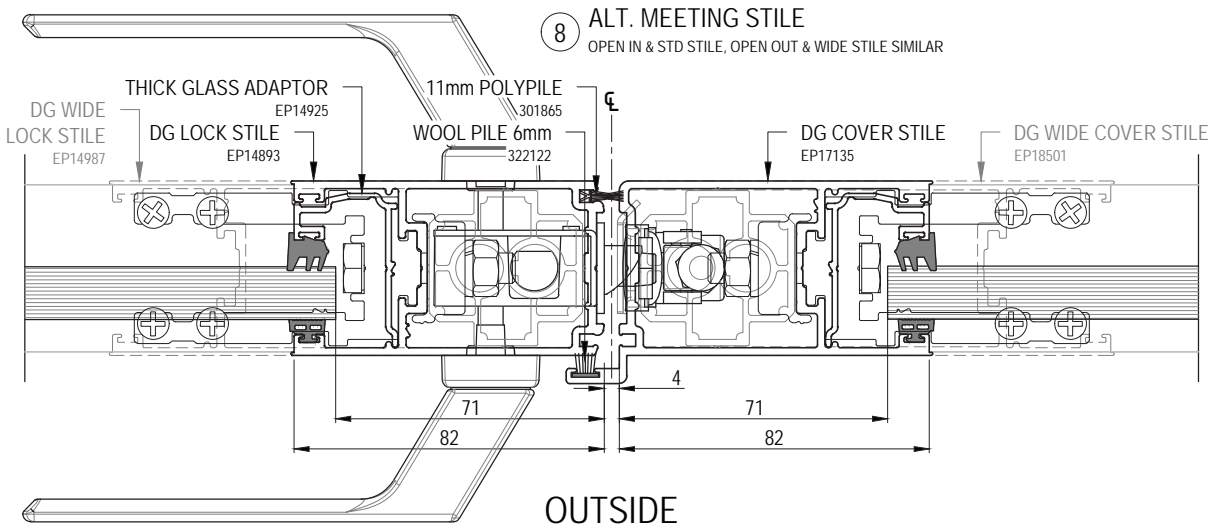
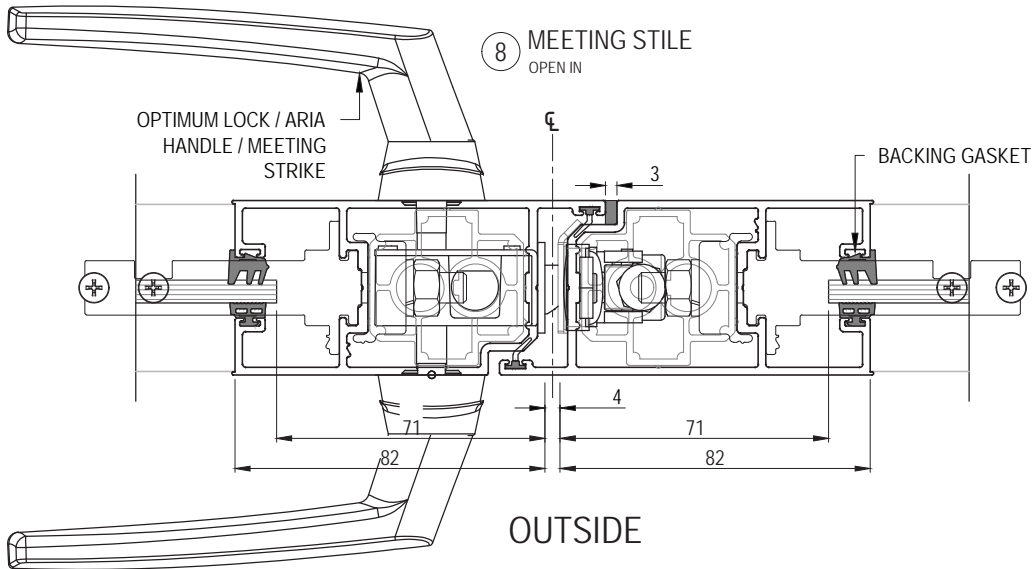
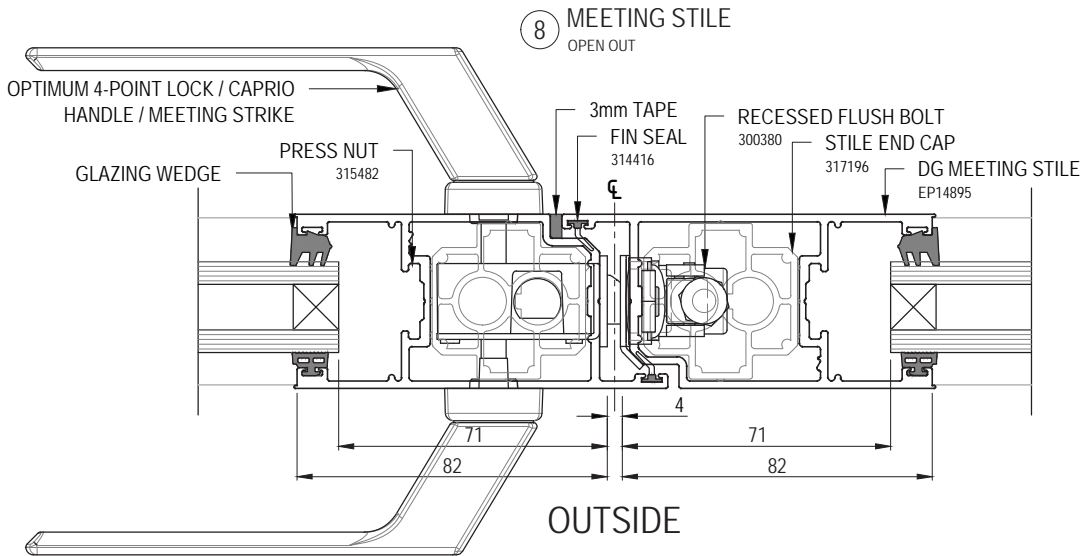

Please read in conjunction with Important Conditions – Index (also available on Capral website)

Vertical Arrangement 01 & 03 - Pivot Head & Sill, Std Rail

Scale 1:2

NOTE: 150mm HEAD AND SG SHOWN AS EXAMPLE OTHER FRAMES, TG & DG SIMILAR ASSEMBLY & GLAZING METHOD NOT SHOWN FOR CLARITY

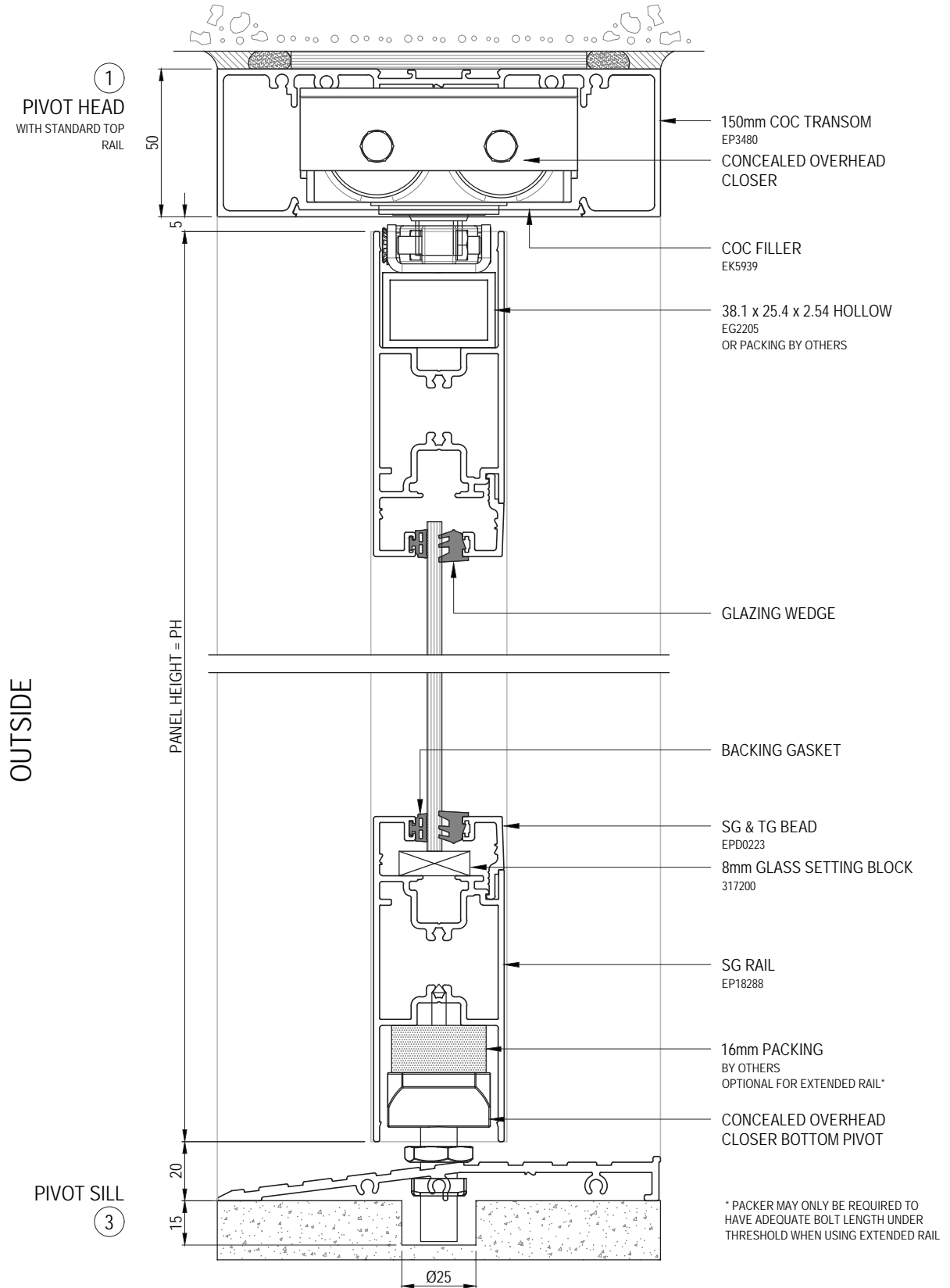

IMPORTANT NOTE: THIS PRODUCT WHEN FABRICATED AS A PIVOT DOOR IS NOT WATER RATED AND DOES NOT CONFORM TO AUSTRALIAN STANDARD AS2047 AND IS INTENDED FOR INTERNAL APPLICATIONS ONLY OR WHERE THE BUILDER MAKES ALLOWANCES TO ADEQUATELY SHELTER THE PRODUCT.

Please read in conjunction with Important Conditions – Index (also available on Capral website)

Vertical Arrangement 01 & 03 - Pivot Head & Sill, Shallow Rail

Scale 1:2

NOTE: 101.6mm HEAD AND SG SHOWN AS EXAMPLE OTHER FRAMES, TG & DG SIMILAR
 SPIGOT OR SPIGOT WITH TIE ROD ASSEMBLY MUST BE USED. GLAZING METHOD NOT SHOWN FOR CLARITY

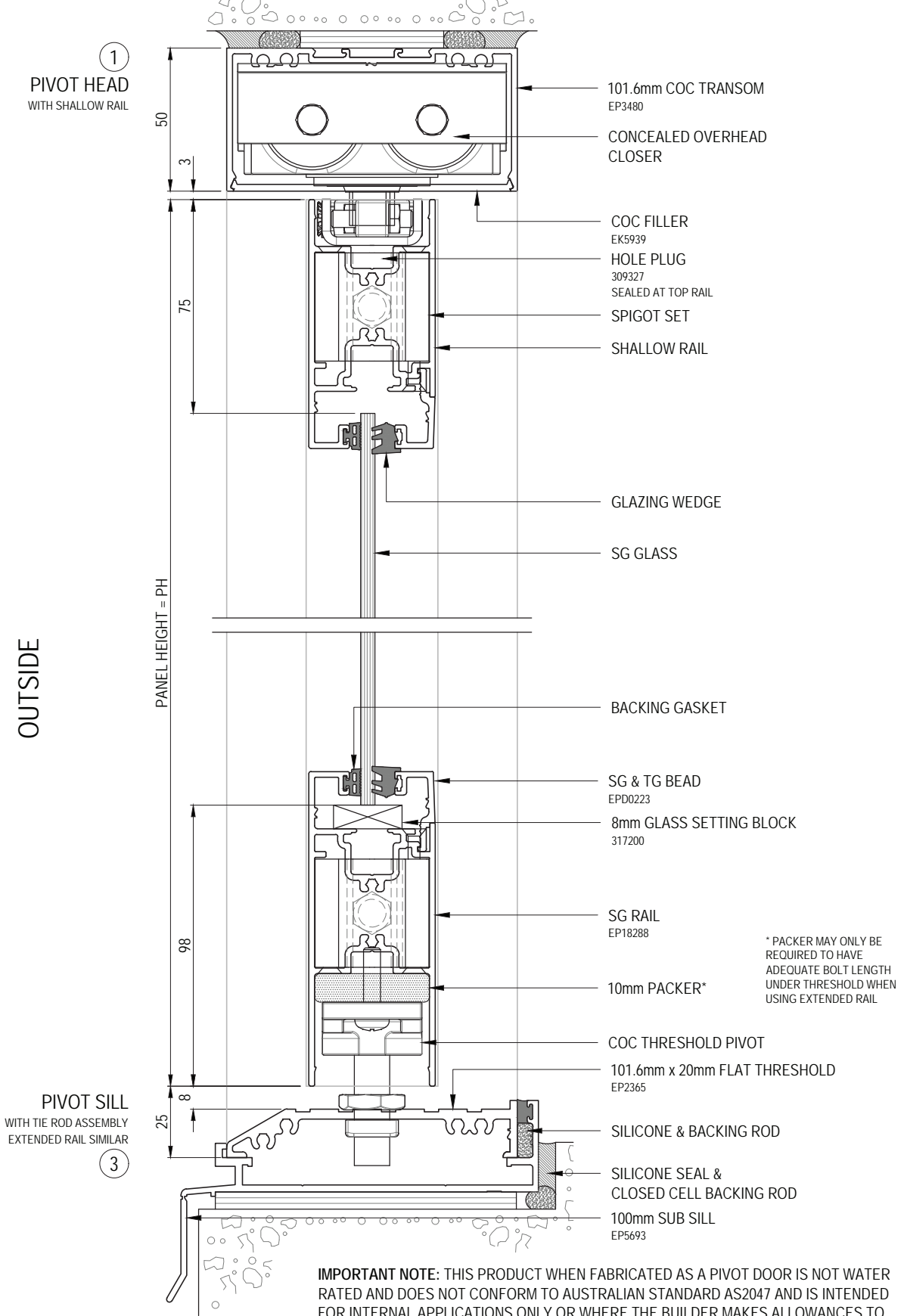

IMPORTANT NOTE: THIS PRODUCT WHEN FABRICATED AS A PIVOT DOOR IS NOT WATER RATED AND DOES NOT CONFORM TO AUSTRALIAN STANDARD AS2047 AND IS INTENDED FOR INTERNAL APPLICATIONS ONLY OR WHERE THE BUILDER MAKES ALLOWANCES TO ADEQUATELY SHELTER THE PRODUCT.

Please read in conjunction with Important Conditions – Index (also available on Capral website)

Vertical Arrangement 04 - Alt. Pivot Head/Transoms

Scale 1:2

NOTE: REFER TO RESPECTIVE FRAMING MANUALS FOR FURTHER FRAMING INFORMATION.

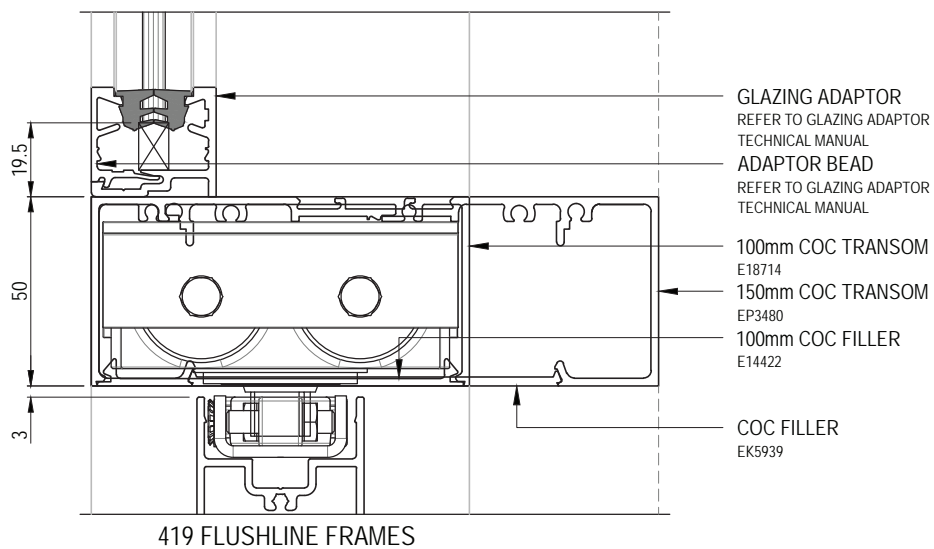
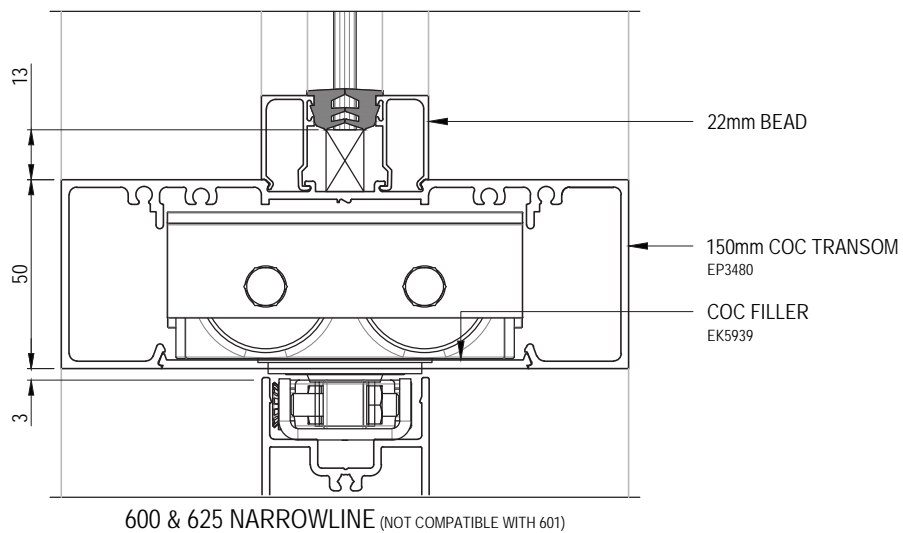
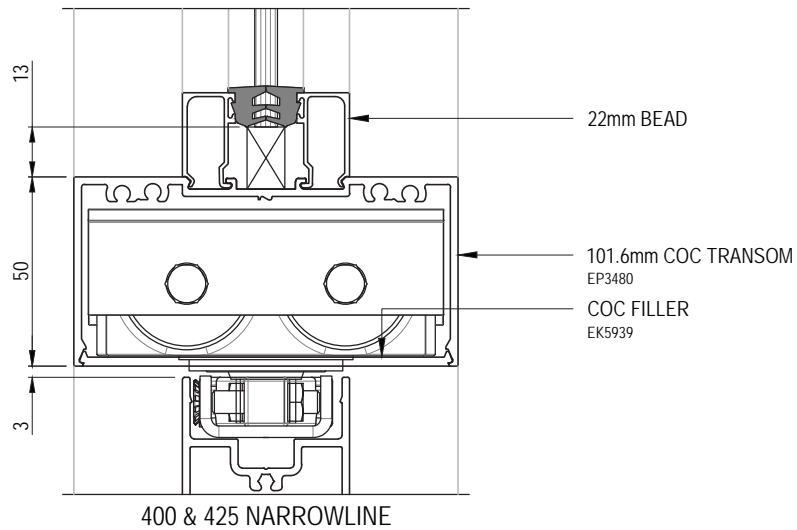

Please read in conjunction with Important Conditions – Index (also available on Capral website)

Horizontal Arrangement 06, 07 & 08 - Pivot Jamb & Meeting Stiles

Scale 1:2

NOTE: SG SHOWN AS EXAMPLE, DG & TG SIMILAR
 400 NARROWLINE FRAME SHOWN AS EXAMPLE, OTHER FRAMES SIMILAR

⑥ PIVOT JAMB

PIVOT LOCK JAMB ⑦

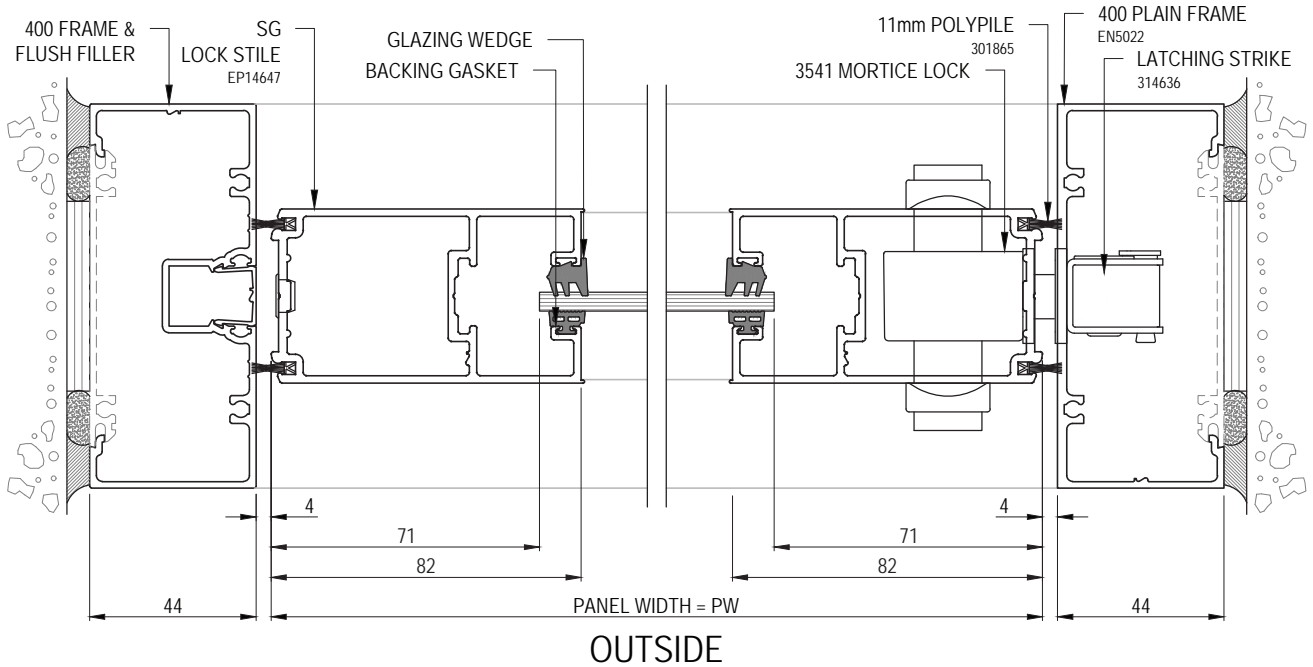

⑧ PIVOT MEETING STILE

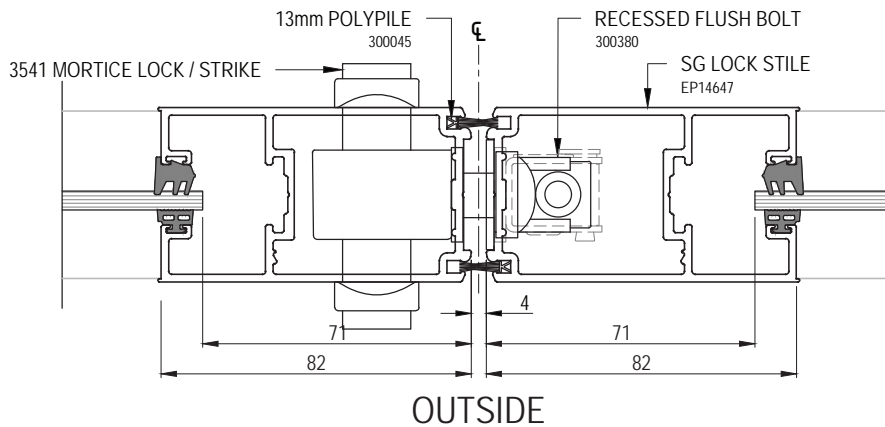

⑧ ALT. PIVOT MEETING STILES

WIDE STILES SHOWN AS EXAMPLE, STD STILES SIMILAR

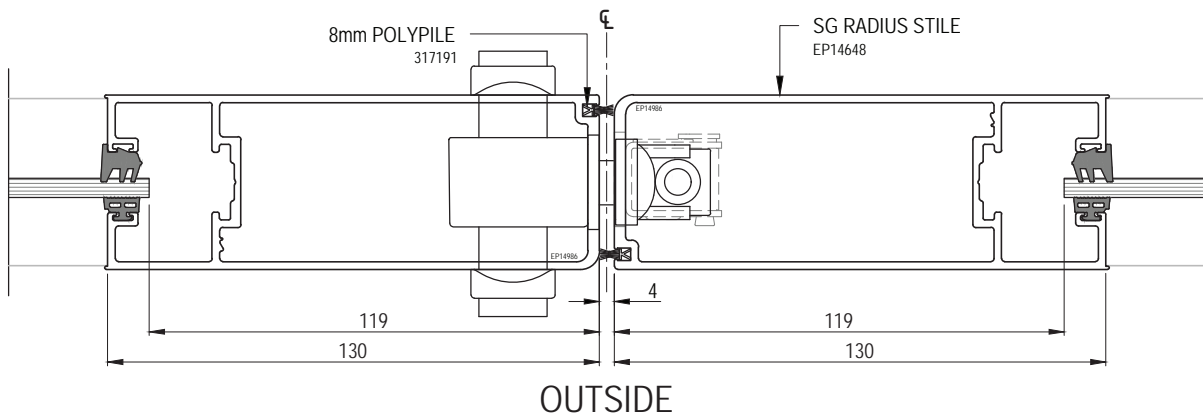

Please read in conjunction with Important Conditions – Index (also available on Capral website)

Vertical Arrangement 01 & 03 - 1022 & 1021 Sliding Floor Tracks

Scale 1:2

IMPORTANT NOTE: THIS PRODUCT WHEN FABRICATED WITH THE BELOW TRACKS ARE NOT WATER RATED AND DO NOT CONFORM TO AUSTRALIAN STANDARD AS2047 AND ARE INTENDED FOR INTERNAL APPLICATIONS ONLY OR WHERE THE BUILDER MAKES ALLOWANCES TO ADEQUATELY SHELTER THE PRODUCT.
ASSEMBLY & GLAZING METHOD NOT SHOWN FOR CLARITY

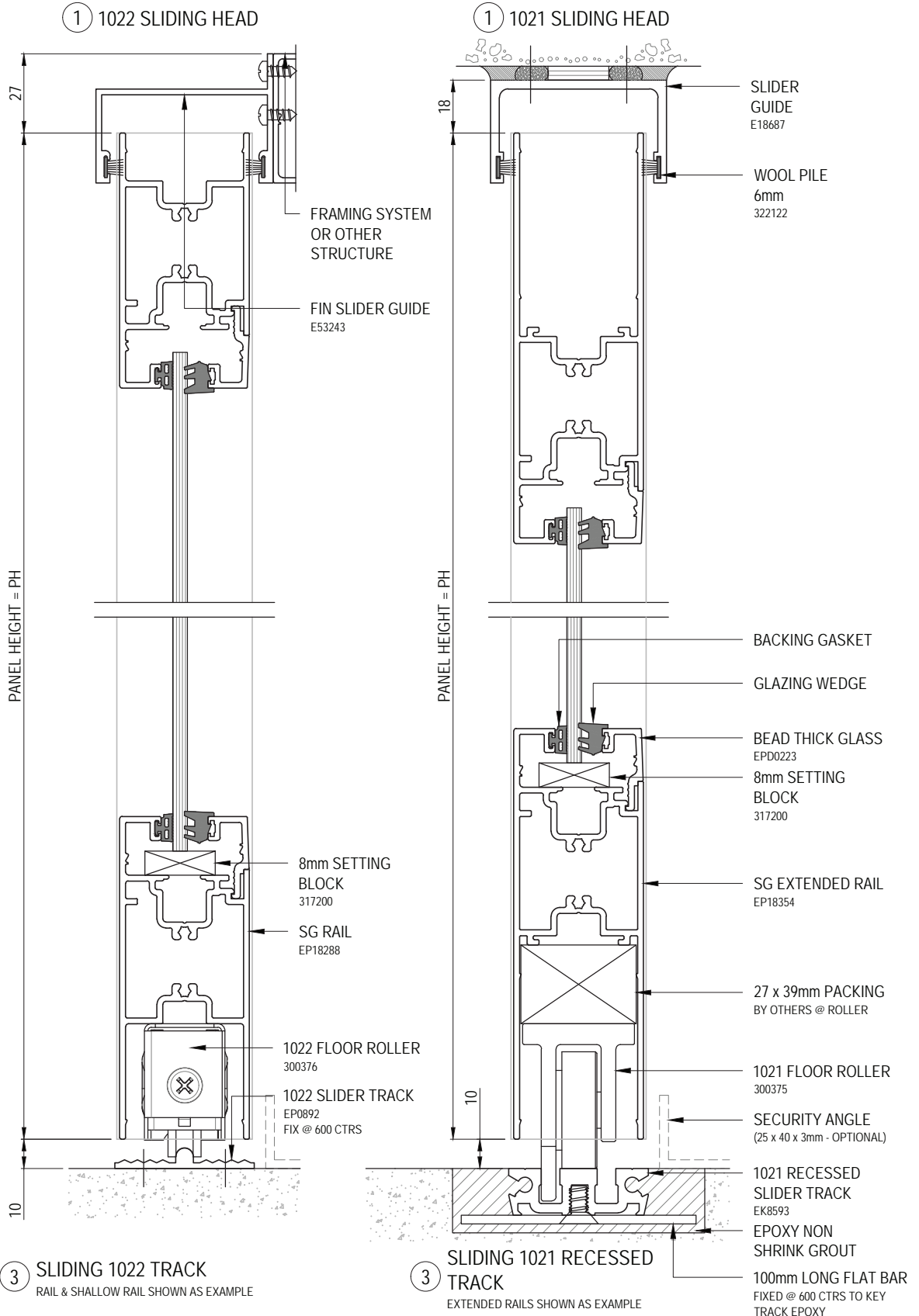

Please read in conjunction with Important Conditions – Index (also available on Capral website)

Vertical Arrangement 01 & 03 - 1030 & 1031 Sliding Head tracks

Scale 1:2

IMPORTANT NOTE: THIS PRODUCT WHEN FABRICATED WITH THE BELOW TRACKS ARE NOT WATER RATED AND DO NOT CONFORM TO AUSTRALIAN STANDARD AS2047 AND ARE INTENDED FOR INTERNAL APPLICATIONS ONLY OR WHERE THE BUILDER MAKES ALLOWANCES TO ADEQUATELY SHELTER THE PRODUCT.
ASSEMBLY & GLAZING METHOD NOT SHOWN FOR CLARITY

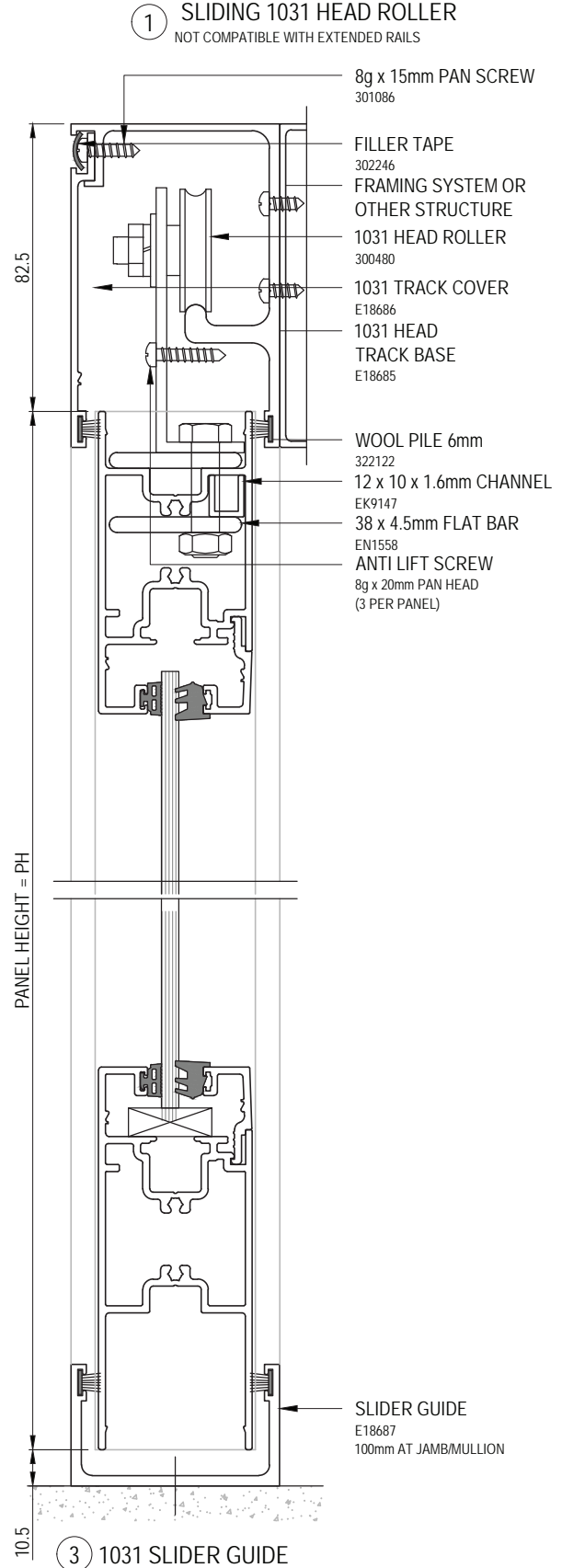
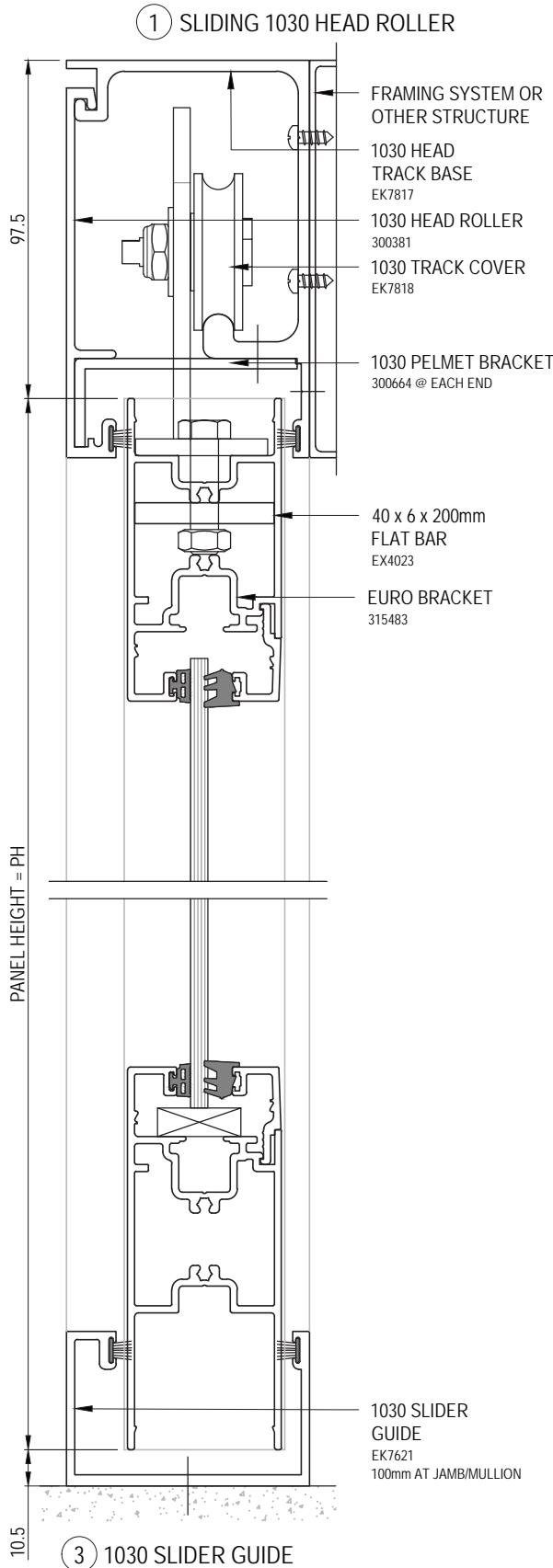

Please read in conjunction with Important Conditions – Index (also available on Capral website)

Vertical Arrangement 01 & 03 - 1061 Sliding Head Track

Scale 1:2

IMPORTANT NOTE: THIS PRODUCT WHEN FABRICATED WITH THE BELOW TRACKS ARE NOT WATER RATED AND DO NOT CONFORM TO AUSTRALIAN STANDARD AS2047 AND ARE INTENDED FOR INTERNAL APPLICATIONS ONLY OR WHERE THE BUILDER MAKES ALLOWANCES TO ADEQUATELY SHELTER THE PRODUCT.
ASSEMBLY & GLAZING METHOD NOT SHOWN FOR CLARITY

①
SLIDING 1061
HEAD ROLLER

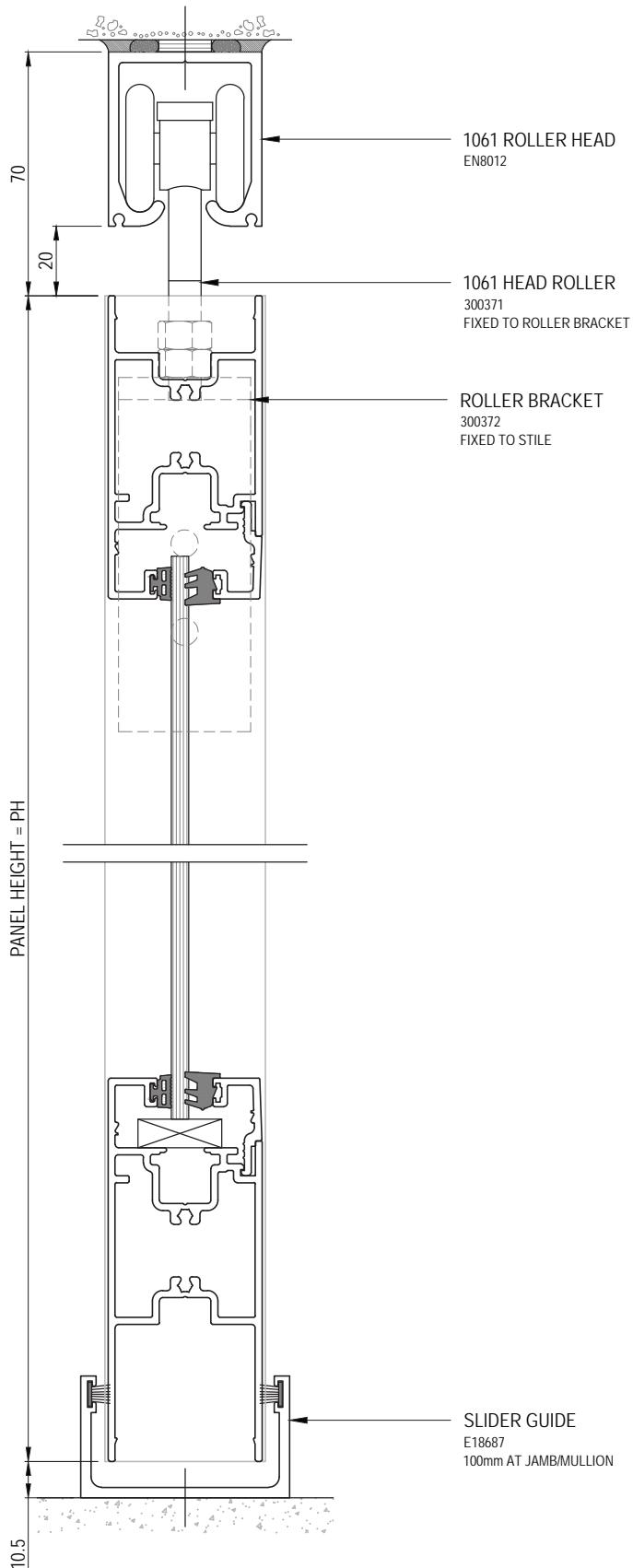

1061 SLIDER GUIDE
③

Please read in conjunction with Important Conditions - Index (also available on Capral website)

Horizontal Arrangement 06 & 07 - Sliding Jamb & Interlocks

Scale 1:2

NOTE: SG SHOWN AS EXAMPLE, DG & TG SIMILAR
ASSEMBLY & GLAZING METHOD NOT SHOWN FOR CLARITY

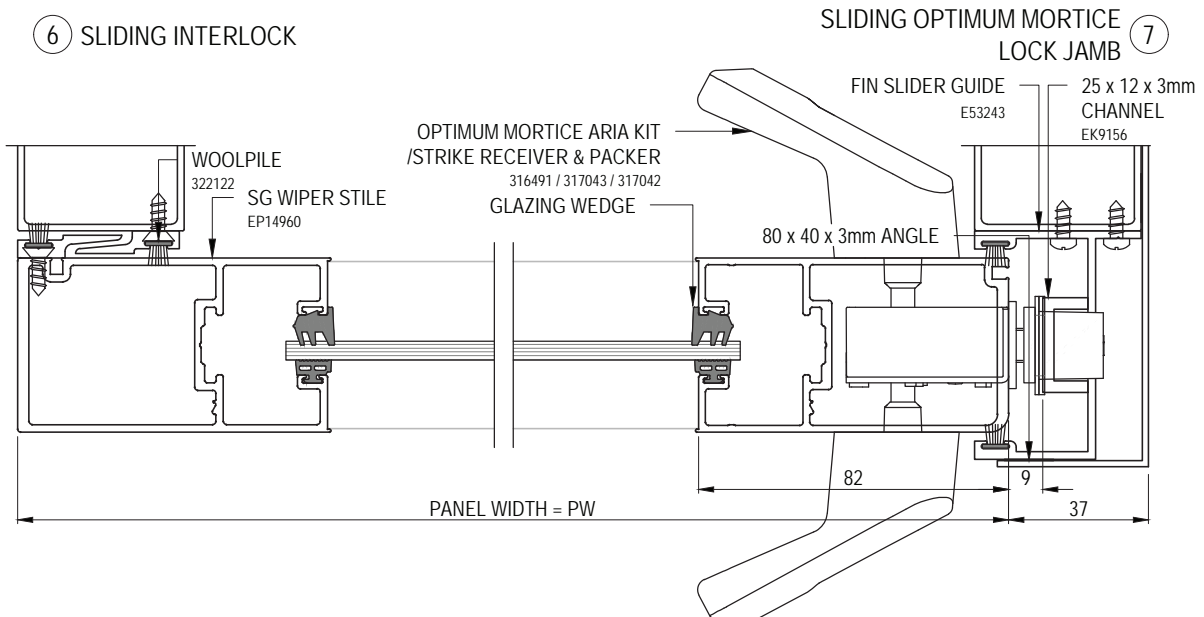
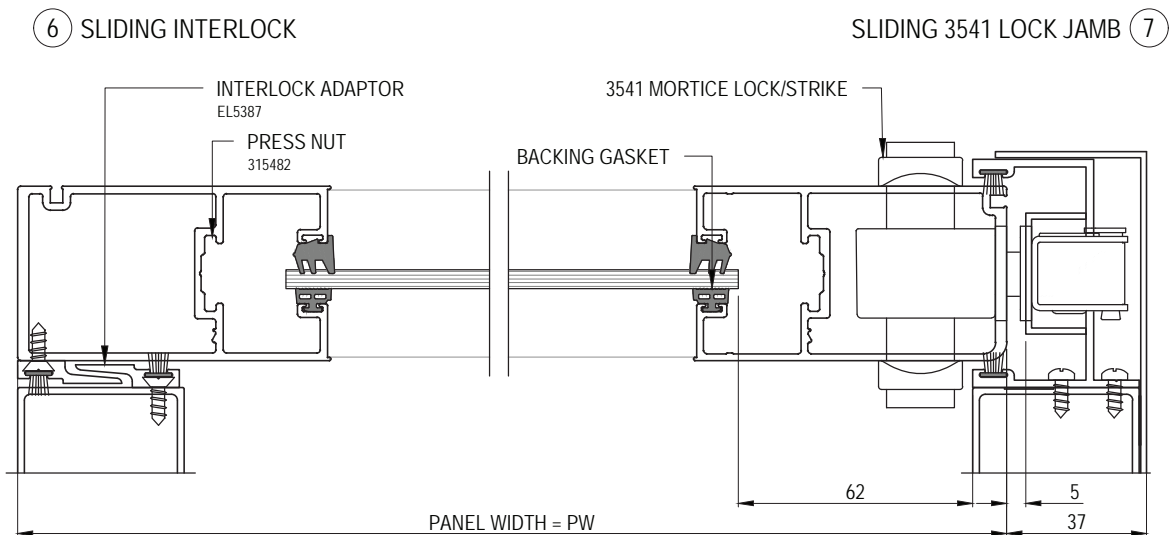
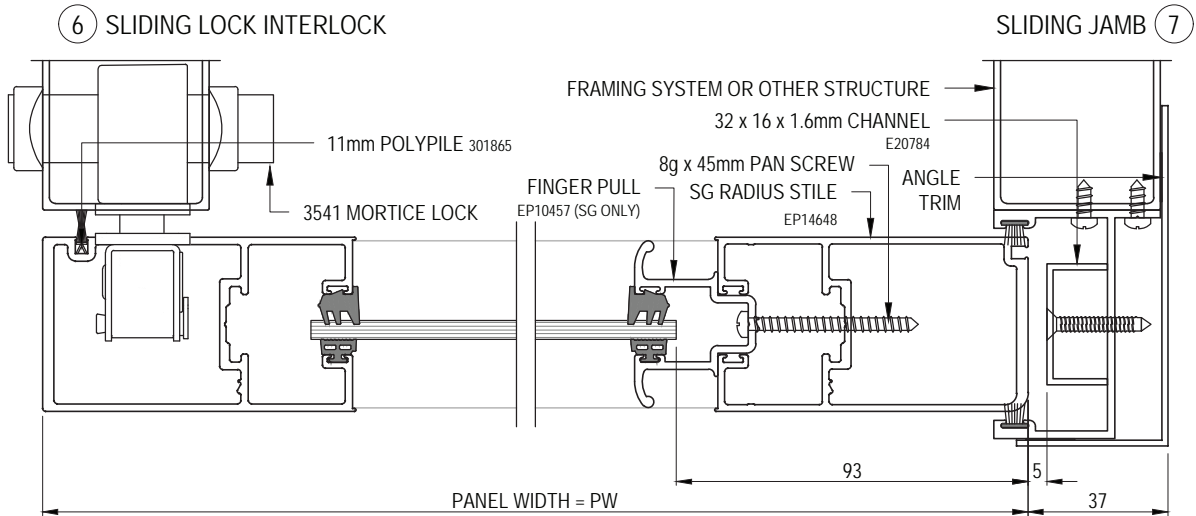

Please read in conjunction with Important Conditions – Index (also available on Capral website)

Horizontal Arrangement 08 - Sliding Meeting Stiles

Scale 1:2

NOTE: SG SHOWN AS EXAMPLE, DG & TG SIMILAR
ASSEMBLY & GLAZING METHOD NOT SHOWN FOR CLARITY

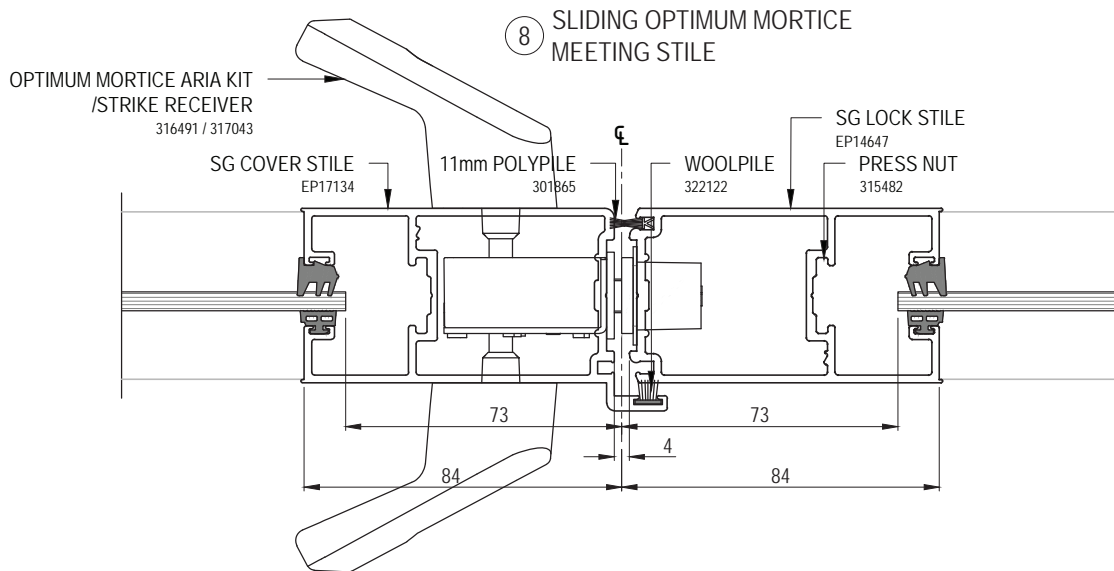
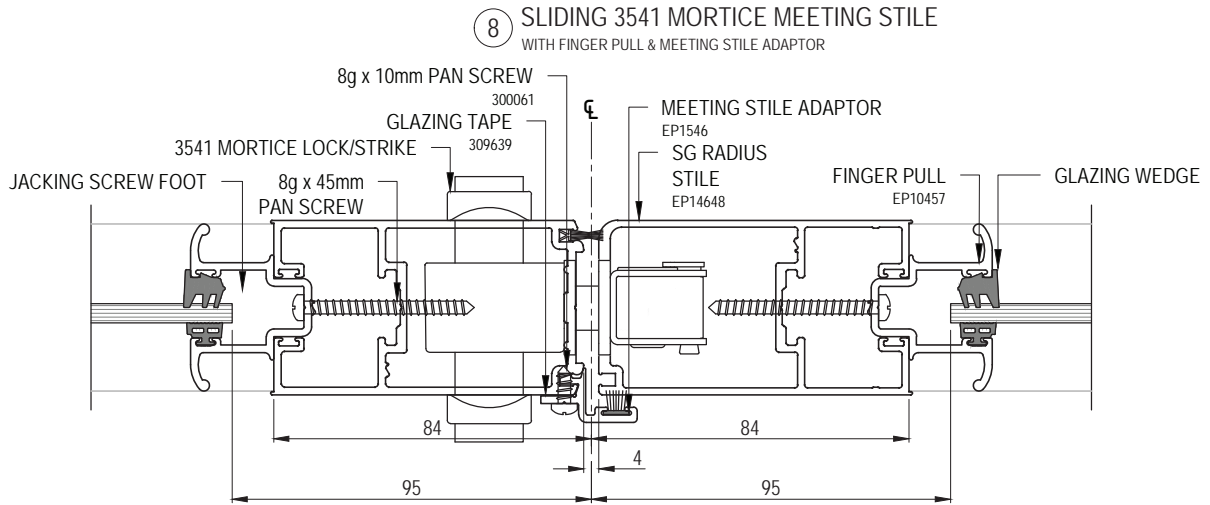

Please read in conjunction with Important Conditions – Index (also available on Capral website)

Vertical Arrangement 04 & 05 - Double Head & Floor Track

Scale 1:2

IMPORTANT NOTE: THIS PRODUCT WHEN FABRICATED WITH THE BELOW TRACKS ARE NOT WATER RATED AND DO NOT CONFORM TO AUSTRALIAN STANDARD AS2047 AND ARE INTENDED FOR INTERNAL APPLICATIONS ONLY OR WHERE THE BUILDER MAKES ALLOWANCES TO ADEQUATELY SHELTER THE PRODUCT.
 PANEL ASSEMBLY & GLAZING METHOD NOR SHOWN FOR CLARITY

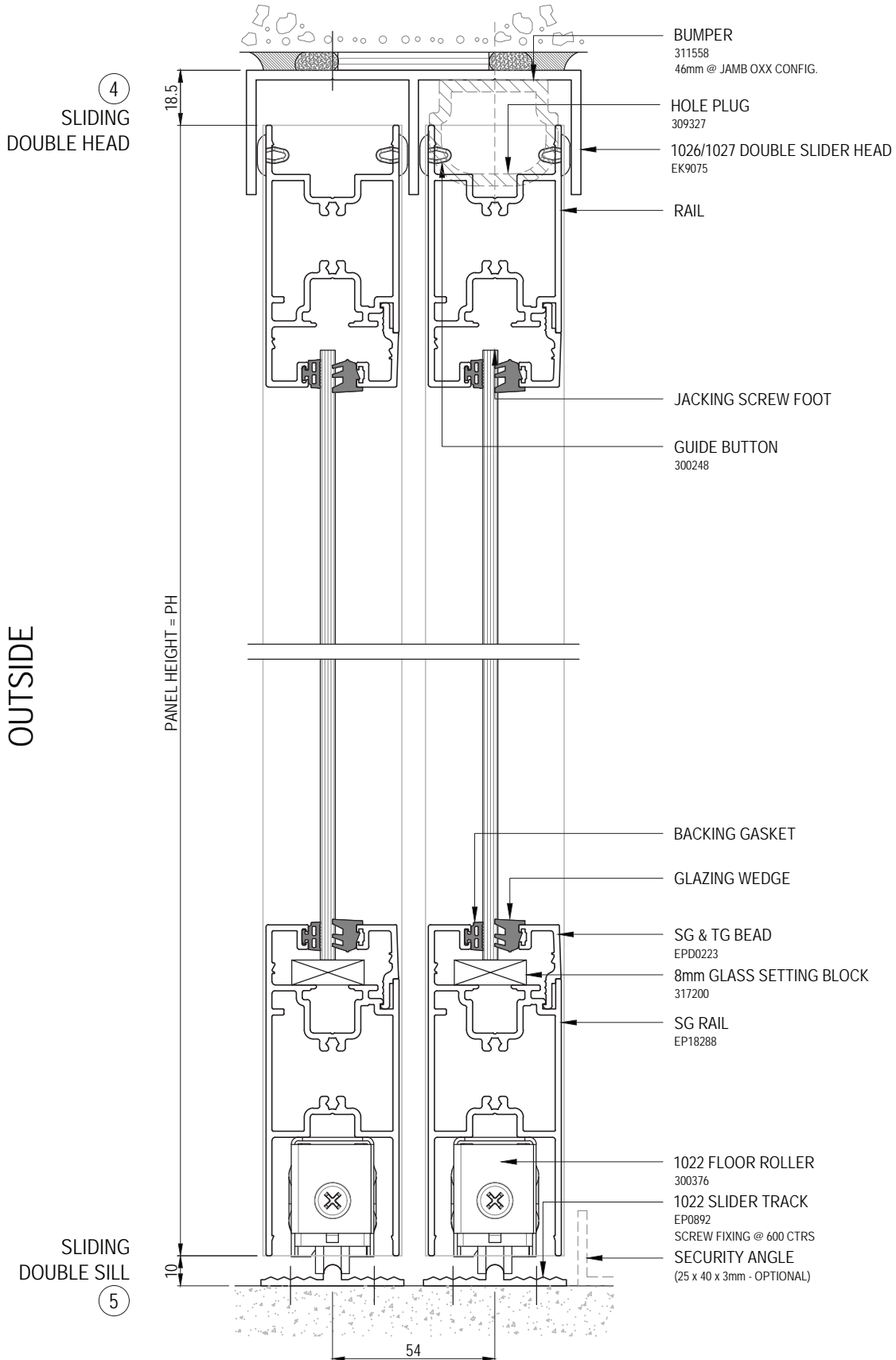

Please read in conjunction with Important Conditions - Index (also available on Capral website)

Horizontal Arrangement 07, 08 & 09 - XXO Jambs & Interlocks

Scale 1:2

NOTE: SG WITH NARROWLINE FRAME SHOWN AS EXAMPLE, DG & TG WITH OTHER FRAMES SIMILAR
 PANEL ASSEMBLY & GLAZING METHOD NOT SHOWN FOR CLARITY

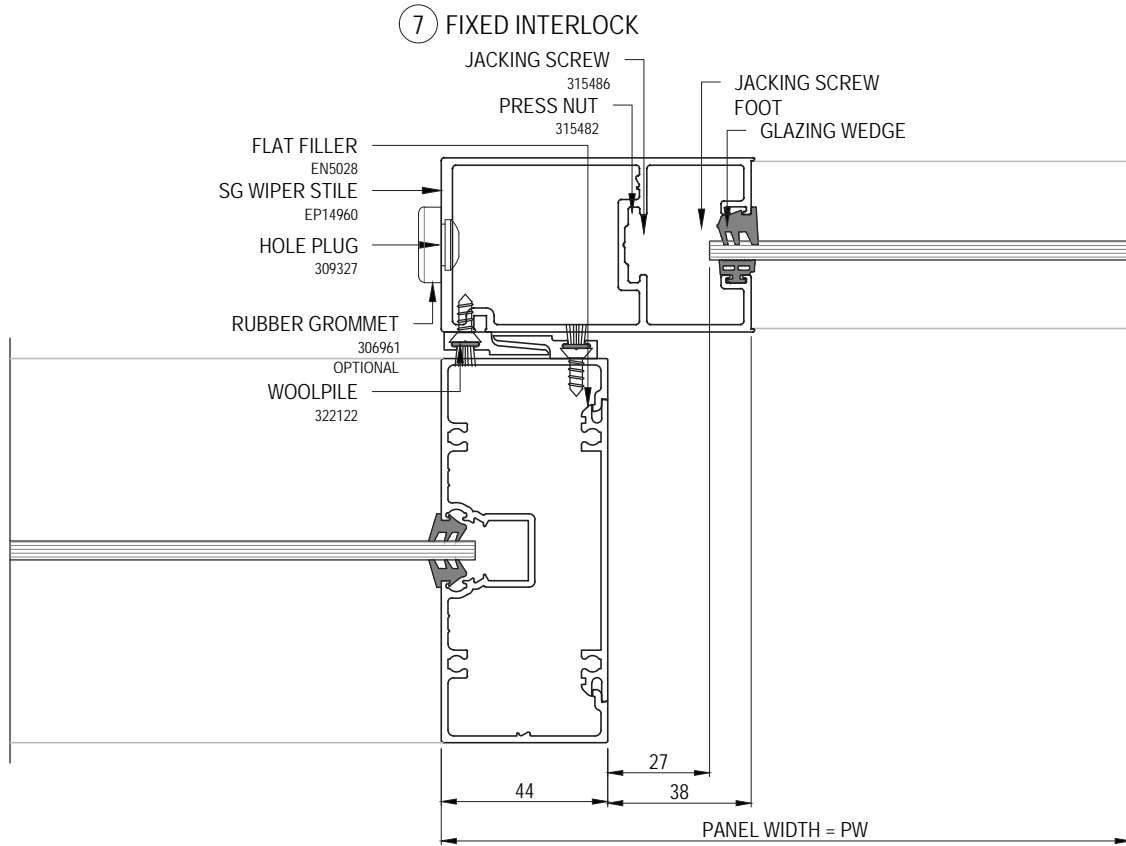

OUTSIDE

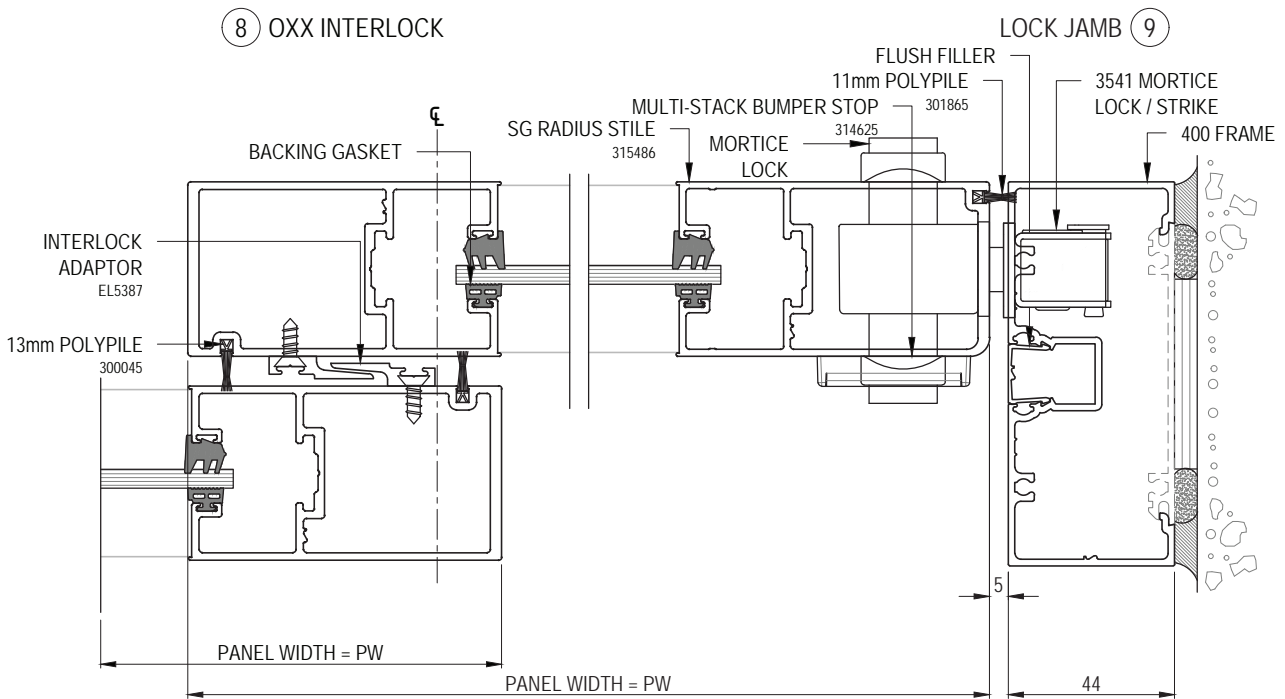

OUTSIDE

Please read in conjunction with Important Conditions - Index (also available on Capral website)

Horizontal Arrangement 07 & 08 - XX Jamb & Interlock

Scale 1:2

NOTE: OPEN OUT & DG SHOWN AS EXAMPLE, MIRROR FOR OPEN IN & SG & TG SIMILAR
 400 NARROWLINE FRAME SHOWN AS EXAMPLE, REFER TO ALT. HEADS FOR OTHER FRAMES
 PANEL ASSEMBLY & GLAZING METHOD NOT SHOWN FOR CLARITY

⑦ XX LOCK JAMB

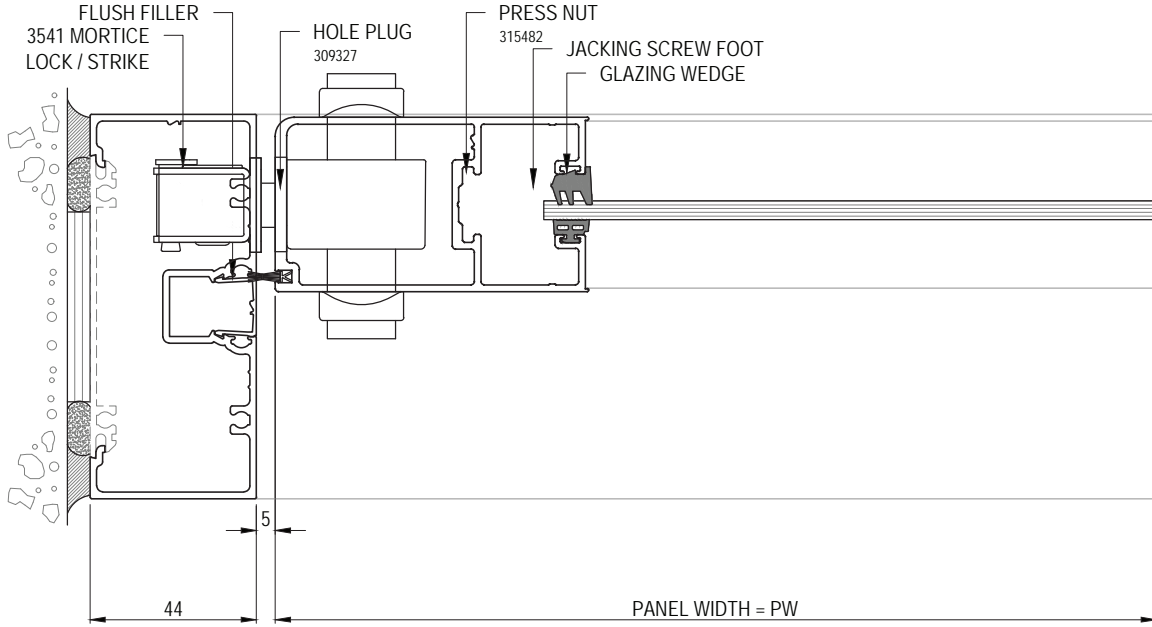

OUTSIDE

⑧ XX INTERLOCK

XX LOCK JAMB ⑦

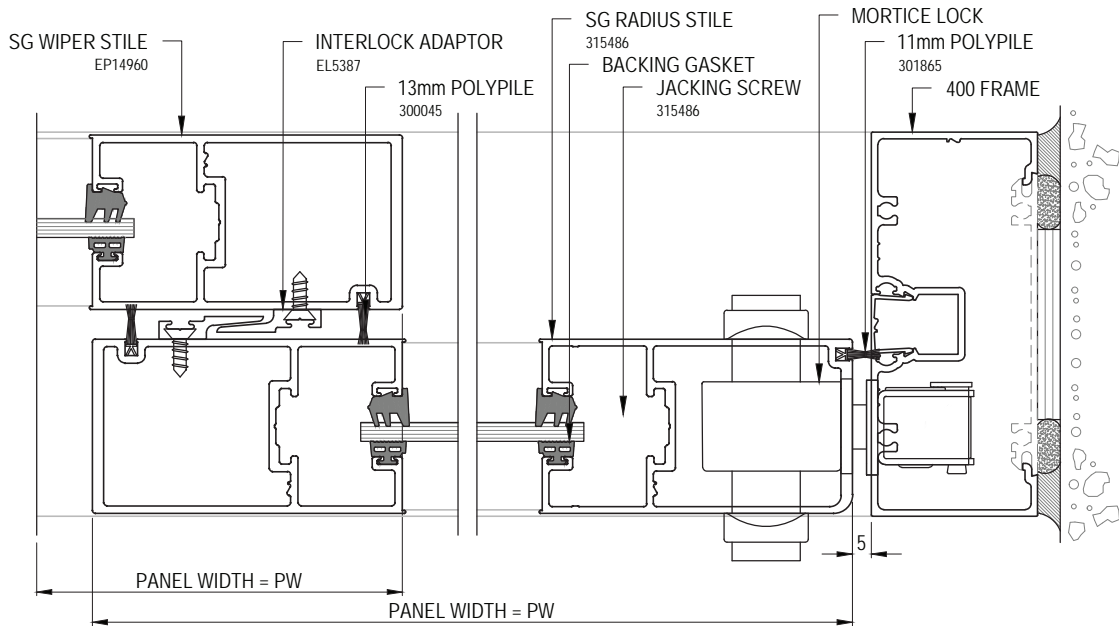

OUTSIDE

Please read in conjunction with Important Conditions – Index (also available on Capral website)

Vertical Arrangement 04 & 05 - Flushline Sliding Panel

Scale 1:2

NOTE: SG SHOWN AS EXAMPLE, DG SIMILAR
 PANEL ASSEMBLY & GLAZING METHOD NOT SHOWN FOR CLARITY

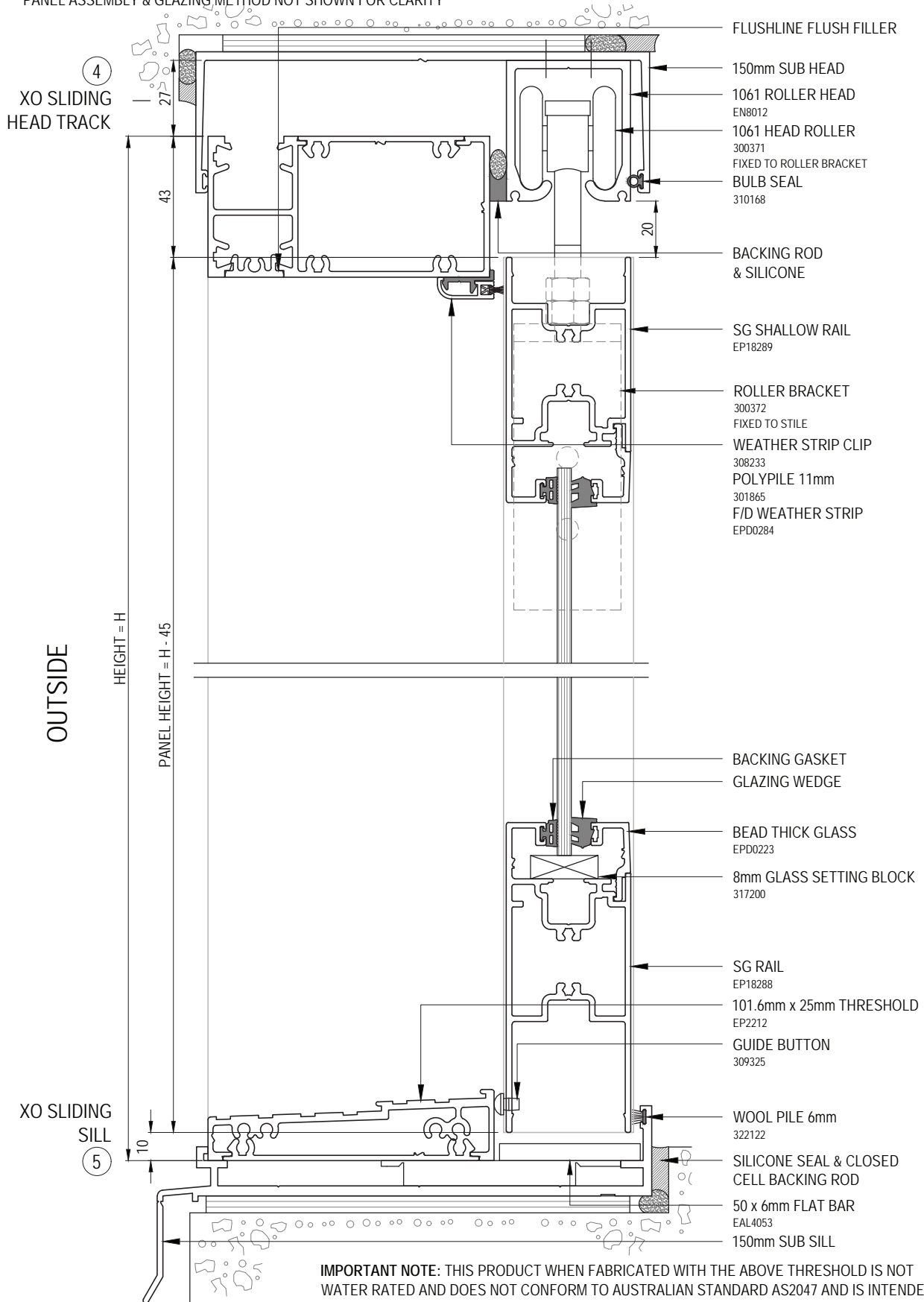

IMPORTANT NOTE: THIS PRODUCT WHEN FABRICATED WITH THE ABOVE THRESHOLD IS NOT WATER RATED AND DOES NOT CONFORM TO AUSTRALIAN STANDARD AS2047 AND IS INTENDED FOR INTERNAL APPLICATIONS ONLY OR WHERE THE BUILDER MAKES ALLOWANCES TO ADEQUATELY SHELTER THE PRODUCT.

Please read in conjunction with Important Conditions - Index (also available on Capral website)

Vertical Arrangement 04 & 05 - Flushline Fixed Panel

Scale 1:2

NOTE: SG SHOWN AS EXAMPLE, DG SIMILAR. REFER TO FLUSHLINE TECHNICAL MANUALS FOR FURTHER FRAME INFORMATION

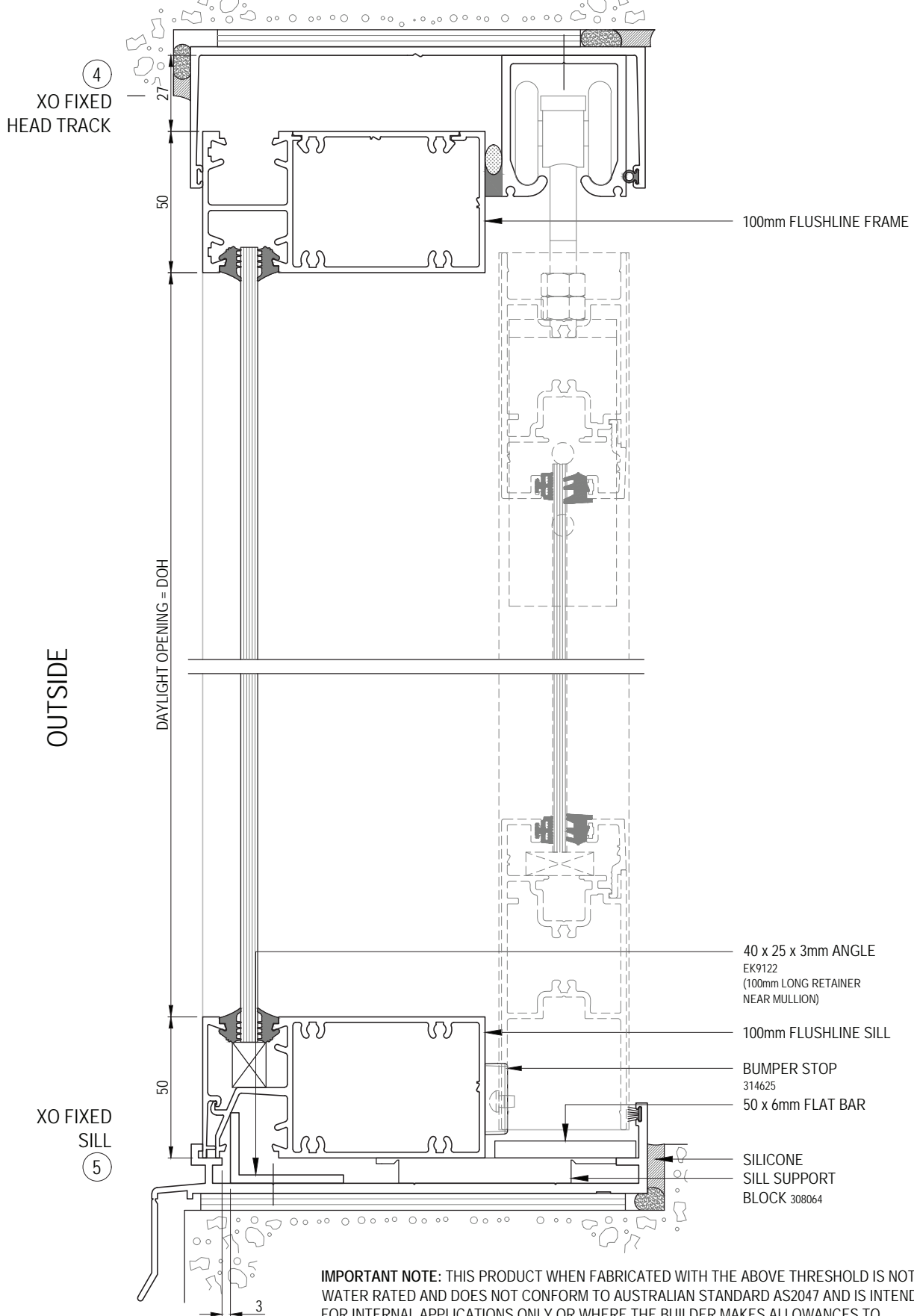

IMPORTANT NOTE: THIS PRODUCT WHEN FABRICATED WITH THE ABOVE THRESHOLD IS NOT WATER RATED AND DOES NOT CONFORM TO AUSTRALIAN STANDARD AS2047 AND IS INTENDED FOR INTERNAL APPLICATIONS ONLY OR WHERE THE BUILDER MAKES ALLOWANCES TO ADEQUATELY SHELTER THE PRODUCT.

Please read in conjunction with Important Conditions – Index (also available on Capral website)

Horizontal Arrangement 07, 08 & 09 - Flushline Jambs & Interlock

Scale 1:2

NOTE: SG SHOWN AS EXAMPLE, DG & TG SIMILAR
 FLUSHLINE FRAME SHOWN AS EXAMPLE, OTHER FRAMES SIMILAR

⑦ XO FIXED JAMB

⑧ XO MULLION

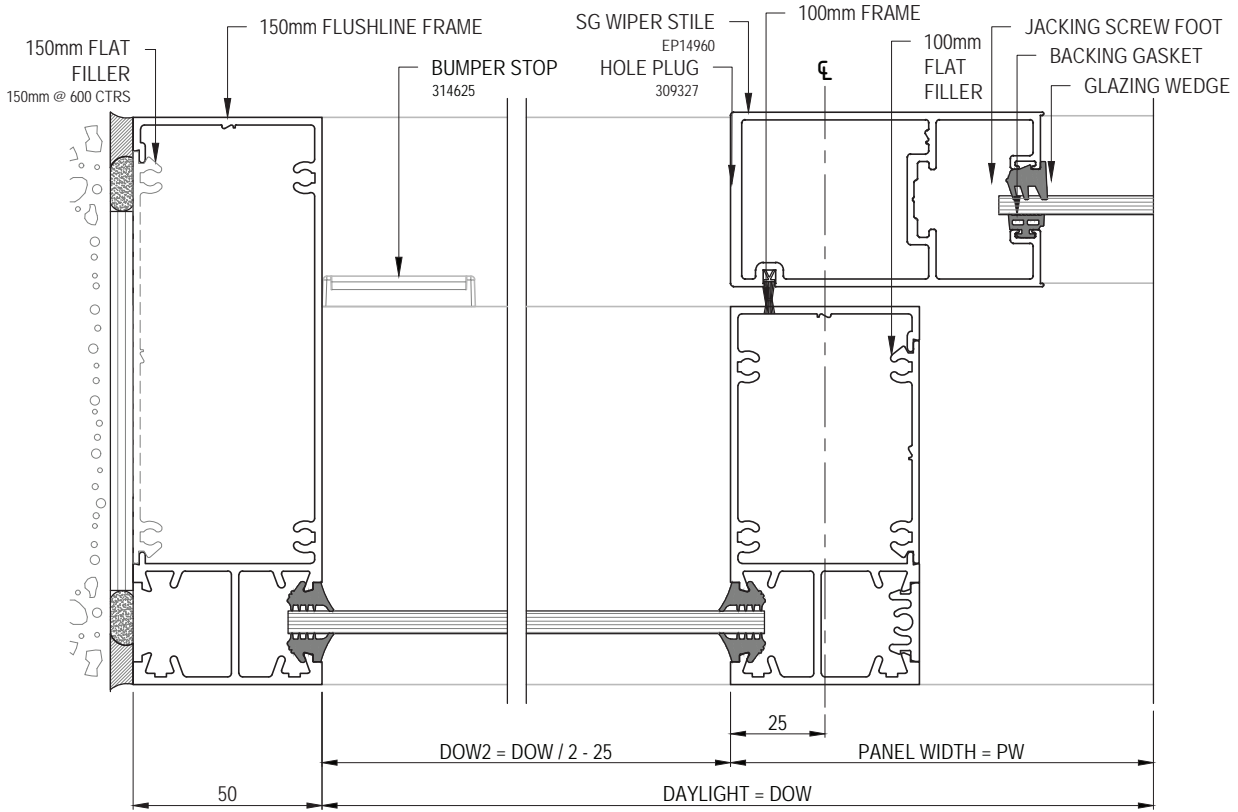

OUTSIDE

XO LOCK JAMB ⑨

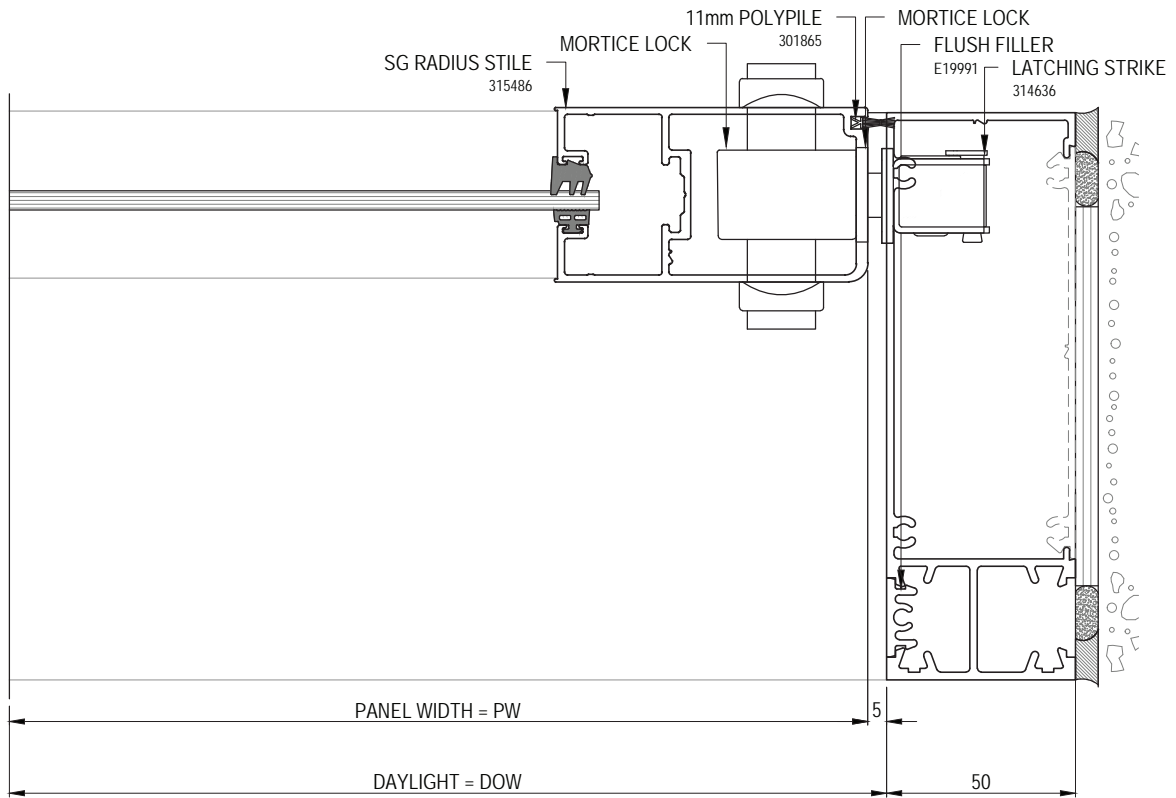

OUTSIDE

Please read in conjunction with Important Conditions - Index (also available on Capral website)

Vertical Arrangement 01 & 03 - Single Automatic Door Head & Sill

Scale 1:4

NOTE: CONTACT DORMA FOR FURTHER DETAILS ON AUTOMATIC ENTRY DOORS

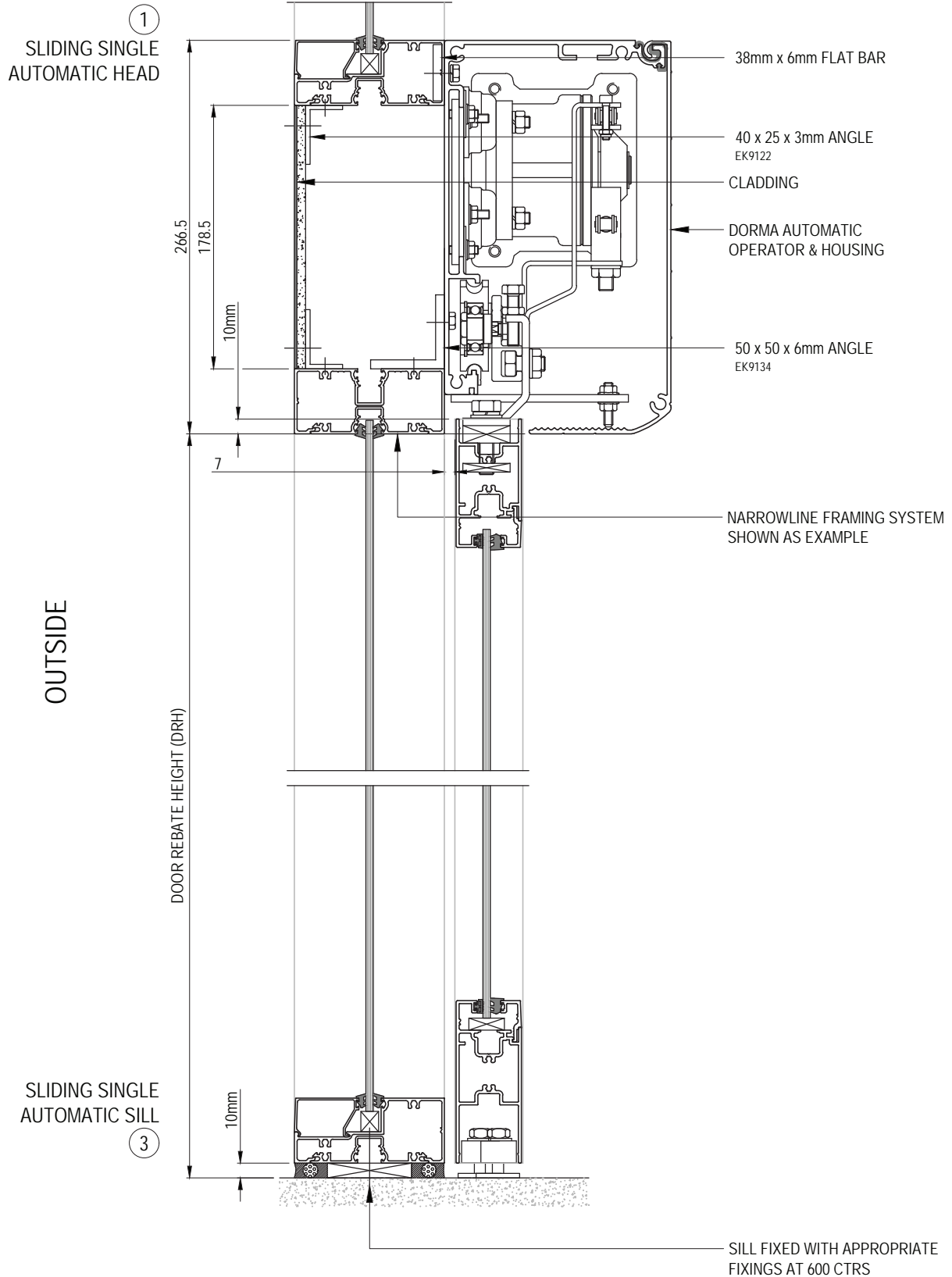

Please read in conjunction with Important Conditions – Index (also available on Capral website)

Vertical Arrangement 04 & 05 - Double Automatic Door Head & Sill

Scale 1:4

IMPORTANT NOTE: THIS PRODUCT WHEN FABRICATED WITH THIS THRESHOLD IS NOT WATER RATED AND DO NOT CONFORM TO AUSTRALIAN STANDARD AS2047 AND ARE INTENDED FOR INTERNAL APPLICATIONS ONLY OR WHERE THE BUILDER MAKES ALLOWANCES TO ADEQUATELY SHELTER THE PRODUCT.

NOTE: CONTACT DORMA FOR FURTHER DETAILS ON AUTOMATIC ENTRY DOORS

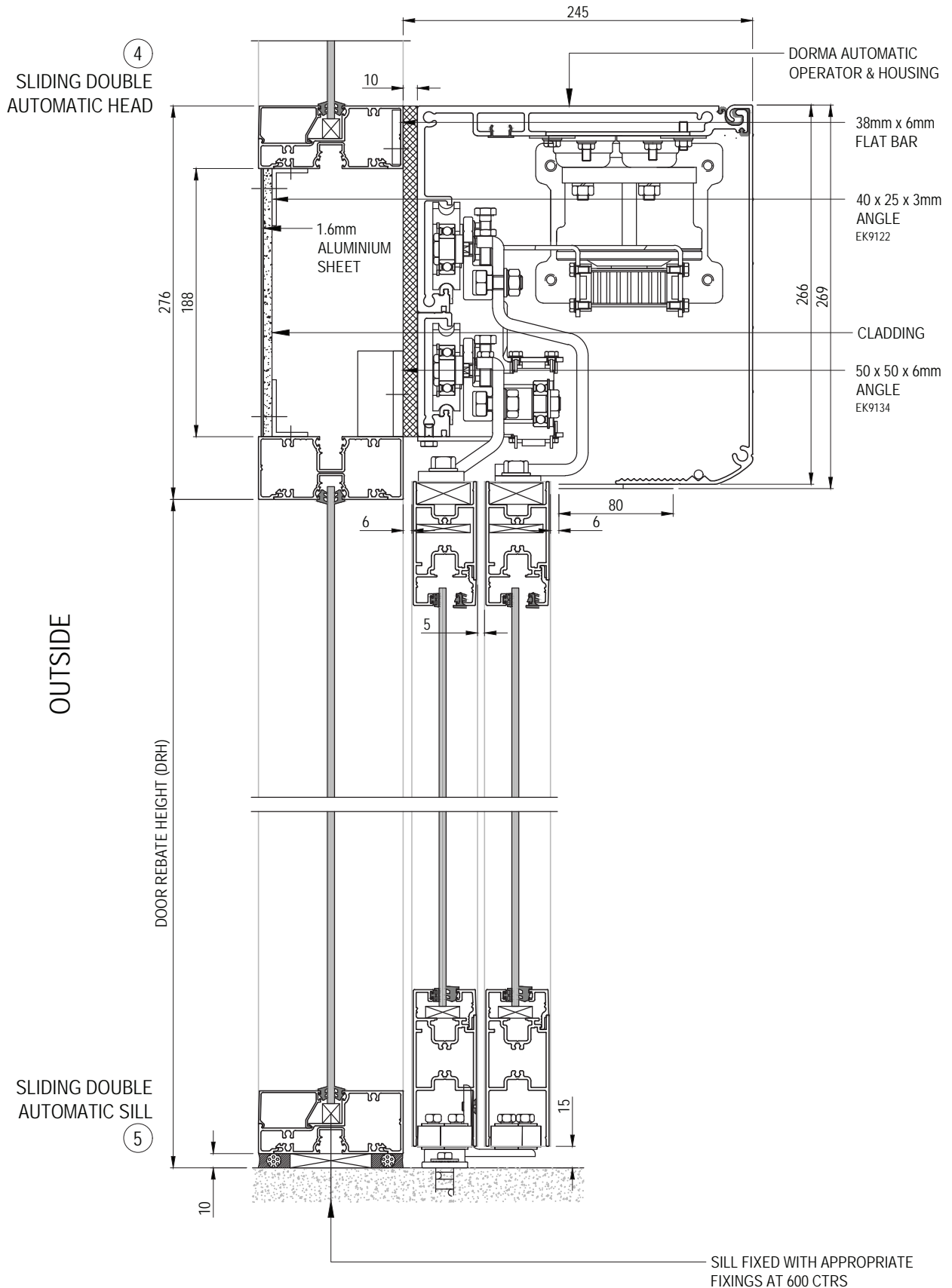

Please read in conjunction with Important Conditions - Index (also available on Capral website)

Horizontal Arrangement 06 & 07 - Automatic Jamb & Interlock

Scale 1:2

NOTE: SG SHOWN AS EXAMPLE, DG & TG SIMILAR
 400 NARROWLINE FRAME SHOWN AS EXAMPLE, OTHER FRAMES SIMILAR

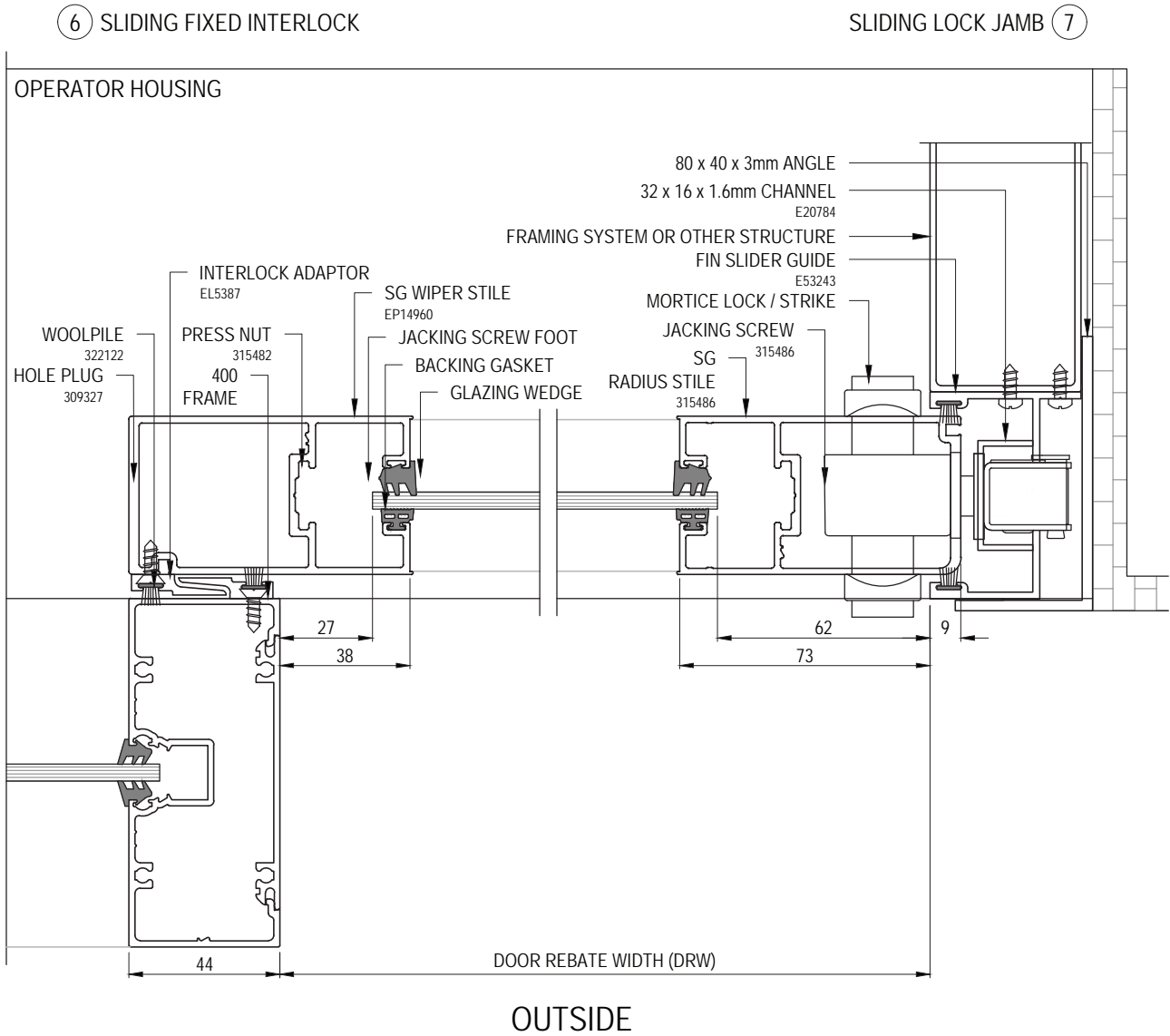

Please read in conjunction with Important Conditions – Index (also available on Capral website)

Vertical Arrangement - Drop Seals

Scale 1:2

NOTE: DG RAIL SHOWN AS EXAMPLE, SG SIMILAR
COMPATIBLE WITH EURO BRACKET & SPIGOT ASSEMBLY

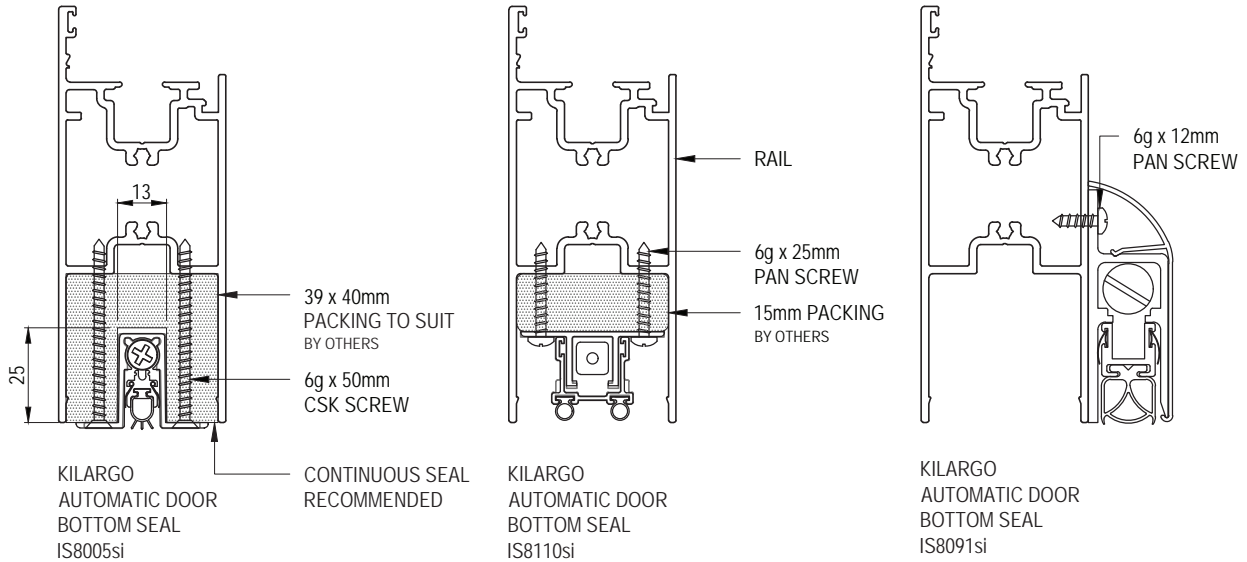

KILARGO Ph: 1300 858 010 Fax: (07) 3861 9266 www.kilargo.com.au

THIS INFORMATION IS INDICATIVE ONLY. CONTACT KILARGO FOR PRODUCT INFORMATION

NOTE: DG RAIL SHOWN AS EXAMPLE, SG SIMILAR
NOT COMPATIBLE WITH EURO BRACKET ASSEMBLY

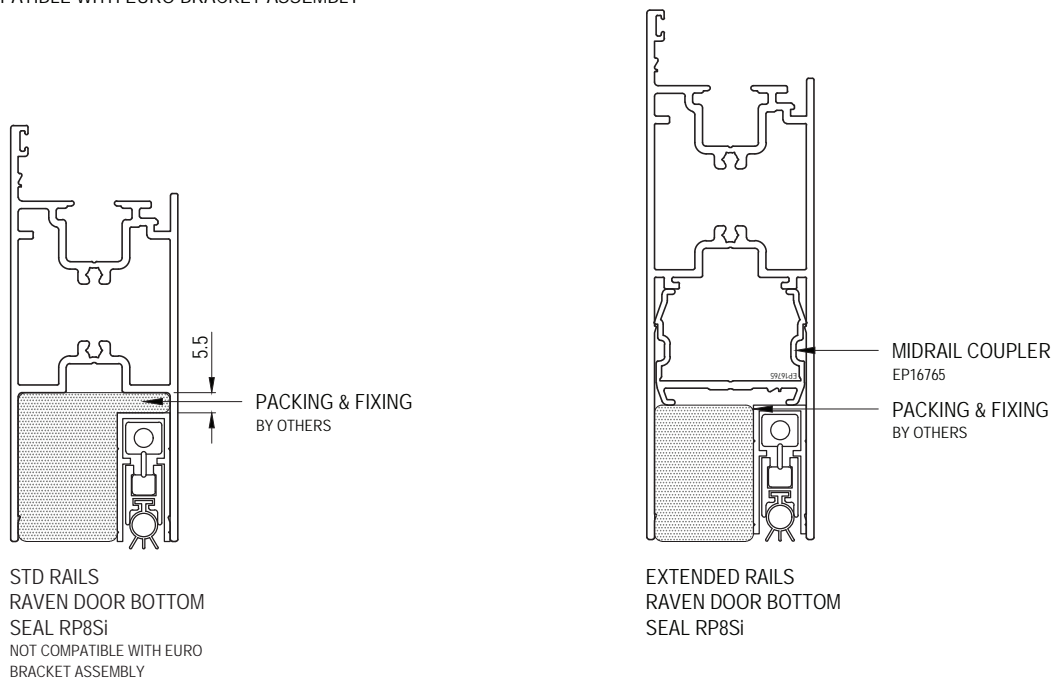

RAVEN Ph: (08) 8384 5455 Fax: (08) 8382 8885 www.raven.com.au

THIS INFORMATION IS INDICATIVE ONLY. CONTACT RAVEN FOR PRODUCT INFORMATION

Please read in conjunction with Important Conditions – Index (also available on Capral website)

Test Report Summary

STRUCTURAL & AIR – TEST REPORT NUMBER: C016-003

Performed by: Capral Mechanical Test Laboratory, Victoria – February, 2016
 Test Drawing Number: 31-898

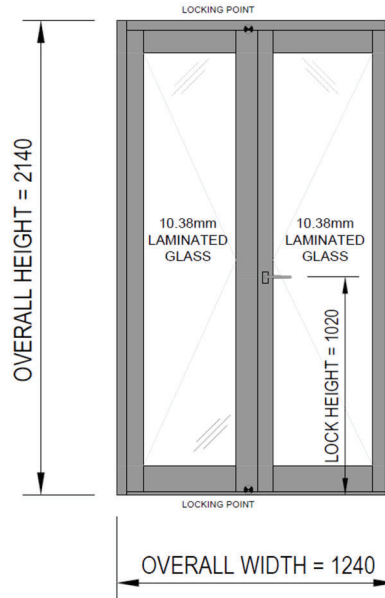

Configuration: Open In French Door into 400 Narrowline – Single Point Lock
 Glass: 10.38mm Laminated Glass
 Bead / Glazing: Internal Bead / Backing Gasket & Glazing Wedge

Approved to Standard: AS4420-1996 (as called up by AS2047-2014)
 Assessed to Standard: AS4420-2016 (as called up by AS2047-2014)

DEFLECTION TEST RESULTS:

	+ Test Pressure	- Test Pressure
Lock Stile: EP14649 (969mm Span)	1501Pa @ L/374 1501Pa @ L/374	1503Pa @ L/210 1503Pa @ L/210
Meeting Stile: EP14649 (2054mm Span)	1501Pa @ L/142 1501Pa @ L/142	1503Pa @ L/293 1503Pa @ L/293

AIR INFILTRATION RESULTS:

2.31 L/s.m² at 75Pa Positive Test Pressure
 3.10 L/s.m² at 75Pa Negative Test Pressure

Achieved High Air Infiltration Level

OPERATING FORCE RESULTS:

17.5N to initiate movement
 17.0N to sustain movement

ULTIMATE STRENGTH RESULTS:

+ Test Pressure	- Test Pressure
1944Pa	2008Pa

Please read in conjunction with Important Conditions – Index (also available on Capral website)

Test Report Summary

STRUCTURAL & AIR – TEST REPORT NUMBER: C016-004

Performed by: Capral Mechanical Test Laboratory, Victoria – February, 2016
 Test Drawing Number: 31-898

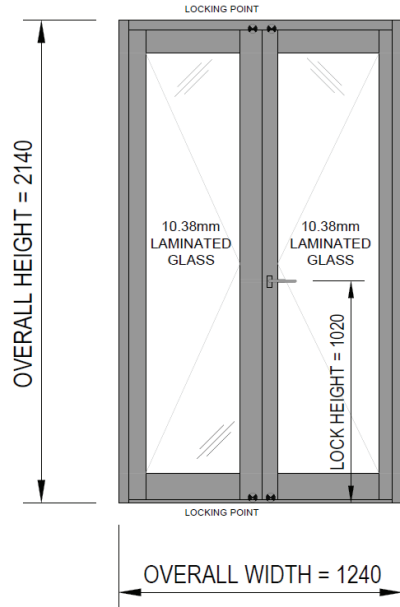

Configuration: Open In French Door into 400 Narrowline – Triple Point Lock
 Glass: 10.38mm Laminated Glass
 Bead / Glazing: Internal Bead / Backing Gasket & Glazing Wedge

Approved to Standard: AS4420-1996 (as called up by AS2047-2014)
 Assessed to Standard: AS4420-2016 (as called up by AS2047-2014)

DEFLECTION TEST RESULTS:

Meeting Stile: EP14649 / EP14649 (2054mm Span)	+ Test Pressure	- Test Pressure
	4010Pa @ L/129 4010Pa @ L/129	4002Pa @ L/123 4002Pa @ L/123

AIR INFILTRATION RESULTS:

1.91 L/s.m² at 75Pa Positive Test Pressure
 1.87 L/s.m² at 75Pa Negative Test Pressure
Achieved High Air Infiltration Level

OPERATING FORCE RESULTS:

17.5N to initiate movement
 17.0N to sustain movement

ULTIMATE STRENGTH RESULTS:

+ Test Pressure	- Test Pressure
5643Pa	5696Pa

Please read in conjunction with Important Conditions – Index (also available on Capral website)

Test Report Summary

STRUCTURAL, AIR & WATER – TEST REPORT NUMBER: C016-005

Performed by: Capral Mechanical Test Laboratory, Victoria – February, 2016

Test Drawing Number: 31-902

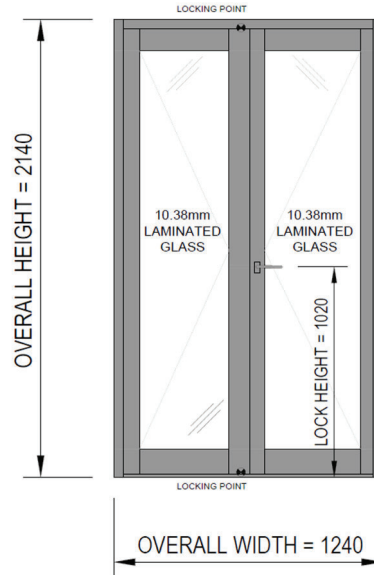

Configuration: Open Out French Door into 400 Narrowline – Single Point Lock
 Glass: 10.38mm Laminated Glass
 Bead / Glazing: Internal Bead / Backing Gasket & Glazing Wedge

Approved to Standard: AS4420-1996 (as called up by AS2047-2014)
 Assessed to Standard: AS4420-2016 (as called up by AS2047-2014)

DEFLECTION TEST RESULTS:

	+ Test Pressure	- Test Pressure
Lock Stile: EP14649 (975mm Span)	1510Pa @ L/166 1510Pa @ L/166	1508Pa @ L/544 1508Pa @ L/544
Meeting Stile: EP14649 (2035mm Span)	1510Pa @ L/262 1510Pa @ L/262	1508Pa @ L/133 1508Pa @ L/133

AIR INFILTRATION RESULTS:

0.70 L/s.m² at 75Pa Positive Test Pressure
 1.28 L/s.m² at 75Pa Negative Test Pressure

Achieved High Air Infiltration Level

WATER PENETRATION RESULTS:

Sill : EP13539

150Pa Pressure for a period of 15mins

OPERATING FORCE RESULTS:

31.0N to initiate movement
 15.5N to sustain movement

ULTIMATE STRENGTH RESULTS:

+ Test Pressure	- Test Pressure
1918Pa	1922Pa

Please read in conjunction with Important Conditions – Index (also available on Capral website)

Test Report Summary

STRUCTURAL, AIR & WATER – TEST REPORT NUMBER: C016-006

Performed by: Capral Mechanical Test Laboratory, Victoria – February, 2016
 Test Drawing Number: 31-902

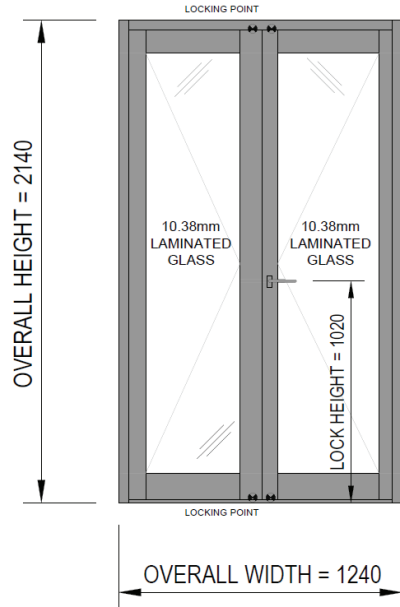

Configuration: Open Out French Door into 400 Narrowline – Triple Point Lock
 Glass: 10.38mm Laminated Glass
 Bead / Glazing: Internal Bead / Backing Gasket & Glazing Wedge

Approved to Standard: AS4420-1996 (as called up by AS2047-2014)
 Assessed to Standard: AS4420-2016 (as called up by AS2047-2014)

DEFLECTION TEST RESULTS:

Meeting Stile: EP14649 / EP14649 (2035mm Span)	+ Test Pressure	- Test Pressure
	4057Pa @ L/112	3999Pa @ L/112
	4057Pa @ L/112	3999Pa @ L/112

AIR INFILTRATION RESULTS:

0.45 L/s.m² at 75Pa Positive Test Pressure
 1.33 L/s.m² at 75Pa Negative Test Pressure
Achieved High Air Infiltration Level

WATER PENETRATION RESULTS:

Sill : EP13539
 153Pa Pressure for a period of 15mins

OPERATING FORCE RESULTS:

31.0N to initiate movement
 15.5N to sustain movement

ULTIMATE STRENGTH RESULTS:

+ Test Pressure	- Test Pressure
5610Pa	4987Pa

Please read in conjunction with Important Conditions – Index (also available on Capral website)

Test Report Summary

STRUCTURAL, AIR & WATER – TEST REPORT NUMBER: C016-007

Performed by: Capral Mechanical Test Laboratory, Victoria – March, 2016

Test Drawing Number: 31-922

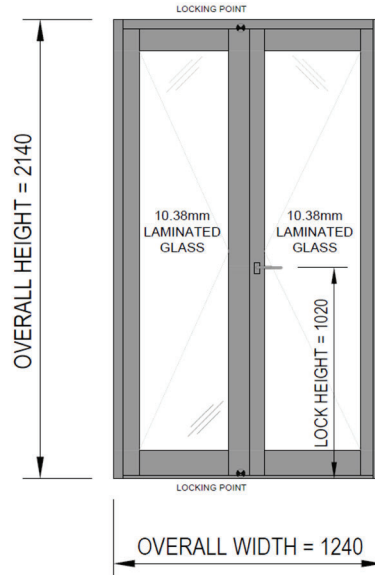

Configuration: Open Out French Door into 400 Narrowline – Single Point Lock
 Glass: 10.38mm Laminated Glass
 Bead / Glazing: Internal Bead / Backing Gasket & Glazing Wedge

Approved to Standard: AS4420-1996 (as called up by AS2047-2014)
 Assessed to Standard: AS4420-2016 (as called up by AS2047-2014)

DEFLECTION TEST RESULTS:

	+ Test Pressure	- Test Pressure
Lock Stile: EP14649 (950mm Span)	1501Pa @ L/151 1501Pa @ L/151	1508Pa @ L/456 1508Pa @ L/456
Meeting Stile: EP14649 (2015mm Span)	1501Pa @ L/298 1501Pa @ L/298	1508Pa @ L/140 1508Pa @ L/140

AIR INFILTRATION RESULTS:

2.07 L/s.m² at 75Pa Positive Test Pressure
 3.26 L/s.m² at 75Pa Negative Test Pressure
Achieved High Air Infiltration Level

WATER PENETRATION RESULTS:

Sill : EP2365
 154Pa Pressure for a period of 15mins

OPERATING FORCE RESULTS:

23.0N to initiate movement
 14.0N to sustain movement

ULTIMATE STRENGTH RESULTS:

+ Test Pressure	- Test Pressure
1951Pa	1950Pa

Please read in conjunction with Important Conditions – Index (also available on Capral website)

Test Report Summary

STRUCTURAL, AIR & WATER – TEST REPORT NUMBER: C016-008

Performed by: Capral Mechanical Test Laboratory, Victoria – March, 2016
 Test Drawing Number: 31-922

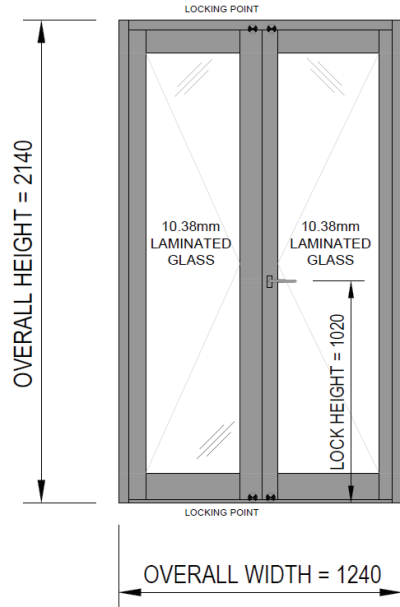

Configuration: Open Out French Door into 400 Narrowline – Triple Point Lock
 Glass: 10.38mm Laminated Glass
 Bead / Glazing: Internal Bead / Backing Gasket & Glazing Wedge

Approved to Standard: AS4420-1996 (as called up by AS2047-2014)
 Assessed to Standard: AS4420-2016 (as called up by AS2047-2014)

DEFLECTION TEST RESULTS:

Meeting Stile: EP14649 / EP14649 (2015mm Span)	+ Test Pressure	- Test Pressure
	4004Pa @ L/126	4002Pa @ L/126
	4004Pa @ L/126	4002Pa @ L/126

AIR INFILTRATION RESULTS:

1.37 L/s.m² at 75Pa Positive Test Pressure
 2.61 L/s.m² at 75Pa Negative Test Pressure
Achieved High Air Infiltration Level

WATER PENETRATION RESULTS:

Sill : EP2365
 153Pa Pressure for a period of 15mins

OPERATING FORCE RESULTS:

23.0N to initiate movement
 14.0N to sustain movement

ULTIMATE STRENGTH RESULTS:

+ Test Pressure	- Test Pressure
5639Pa	5678Pa

Please read in conjunction with Important Conditions – Index (also available on Capral website)

Test Report Summary

STRUCTURAL – TEST REPORT NUMBER: C016-009

Performed by: Capral Mechanical Test Laboratory, Victoria – March, 2016
 Test Drawing Number: 31-914

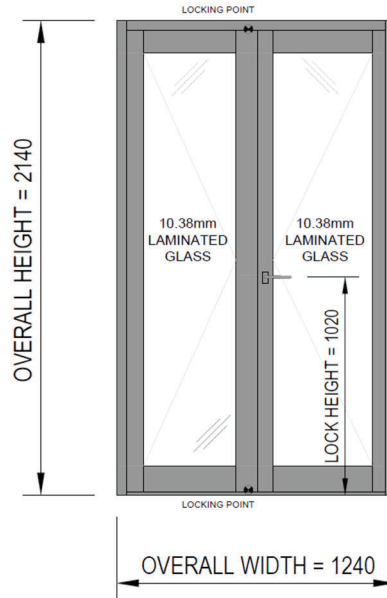

Configuration: Open In French Door into 400 Narrowline – Single Point Lock
 Glass: 10.38mm Laminated Glass
 Bead / Glazing: Internal Bead / Backing Gasket & Glazing Wedge

Approved to Standard: AS4420-1996 (as called up by AS2047-2014)
 Assessed to Standard: AS4420-2016 (as called up by AS2047-2014)

ULTIMATE STRENGTH RESULTS:

+ Test Pressure
 1911Pa

- Test Pressure
 1944Pa

Test Report Summary

STRUCTURAL – TEST REPORT NUMBER: C016-010

Performed by: Capral Mechanical Test Laboratory, Victoria – March, 2016
 Test Drawing Number: 31-914

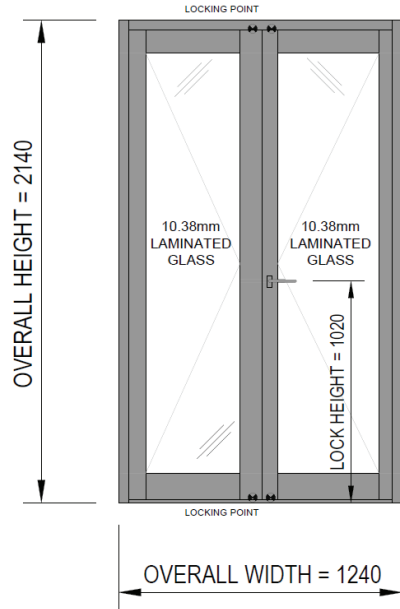

Configuration: Open In French Door into 400 Narrowline – Triple Point Lock
 Glass: 10.38mm Laminated Glass
 Bead / Glazing: Internal Bead / Backing Gasket & Glazing Wedge

Approved to Standard: AS4420-1996 (as called up by AS2047-2014)
 Assessed to Standard: AS4420-2016 (as called up by AS2047-2014)

ULTIMATE STRENGTH RESULTS:

+ Test Pressure
 5654Pa

- Test Pressure
 5709Pa

Test Report Summary

STRUCTURAL & AIR – TEST REPORT NUMBER: C016-011

Performed by: Capral Mechanical Test Laboratory, Victoria – March, 2016
 Test Drawing Number: 31-903

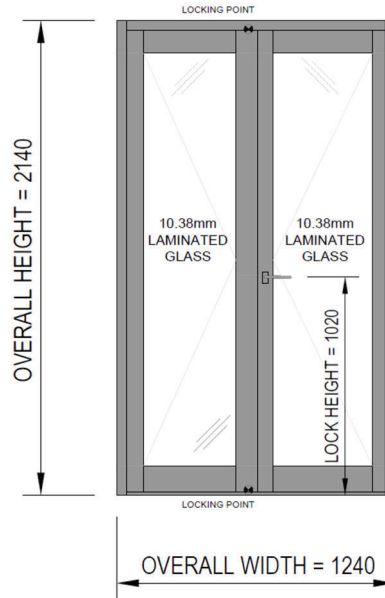

Configuration: Open Out French Door into 400 Narrowline – Single Point Lock
 Glass: 10.38mm Laminated Glass
 Bead / Glazing: Internal Bead / Backing Gasket & Glazing Wedge

Approved to Standard: AS4420-1996 (as called up by AS2047-2014)
 Assessed to Standard: AS4420-2016 (as called up by AS2047-2014)

DEFLECTION TEST RESULTS:

Lock Stile: EP14649 (950mm Span)	+ Test Pressure	- Test Pressure
	1503Pa @ L/156	1505Pa @ L/456
	1503Pa @ L/156	1505Pa @ L/456

AIR INFILTRATION RESULTS:

2.08 L/s.m² at 75Pa Positive Test Pressure
 2.91 L/s.m² at 75Pa Negative Test Pressure
Achieved High Air Infiltration Level

OPERATING FORCE RESULTS:

47.0N to initiate movement
 13.5N to sustain movement

ULTIMATE STRENGTH RESULTS:

+ Test Pressure	- Test Pressure
1990Pa	1997Pa

Please read in conjunction with Important Conditions – Index (also available on Capral website)

Test Report Summary

STRUCTURAL & AIR – TEST REPORT NUMBER: C016-012

Performed by: Capral Mechanical Test Laboratory, Victoria – March, 2016
 Test Drawing Number: 31-903

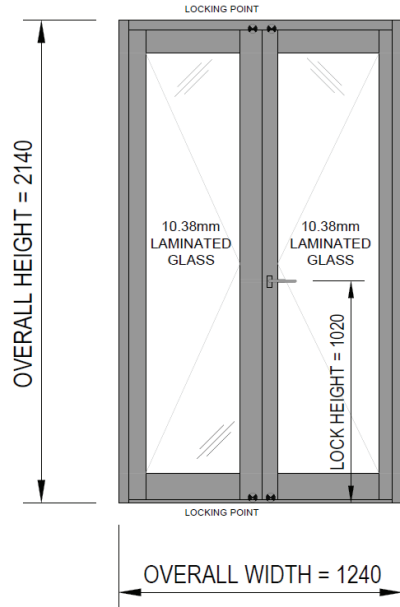

Configuration: Open Out French Door into 400 Narrowline – Triple Point Lock
 Glass: 10.38mm Laminated Glass
 Bead / Glazing: Internal Bead / Backing Gasket & Glazing Wedge

Approved to Standard: AS4420-1996 (as called up by AS2047-2014)
 Assessed to Standard: AS4420-2016 (as called up by AS2047-2014)

DEFLECTION TEST RESULTS:

Meeting Stile: EP14649 / EP14649 (2015mm Span)	+ Test Pressure	- Test Pressure
	4013Pa @ L/125 4013Pa @ L/125	4002Pa @ L/130 4002Pa @ L/130

AIR INFILTRATION RESULTS:

1.58 L/s.m² at 75Pa Positive Test Pressure
 2.09 L/s.m² at 75Pa Negative Test Pressure
Achieved High Air Infiltration Level

OPERATING FORCE RESULTS:

47.0N to initiate movement
 13.5N to sustain movement

ULTIMATE STRENGTH RESULTS:

+ Test Pressure	- Test Pressure
5658Pa	5709Pa

Please read in conjunction with Important Conditions – Index (also available on Capral website)

Test Report Summary

STRUCTURAL & AIR – TEST REPORT NUMBER: C016-013

Performed by: Capral Mechanical Test Laboratory, Victoria – March, 2016
 Test Drawing Number: 31-909

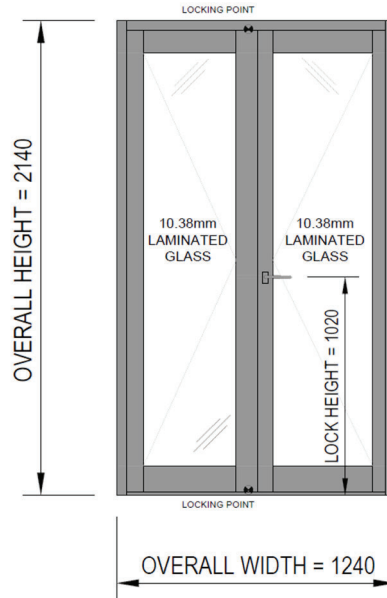

Configuration: Open In French Door into 400 Narrowline – Single Point Lock
 Glass: 10.38mm Laminated Glass
 Bead / Glazing: Internal Bead / Backing Gasket & Glazing Wedge

Approved to Standard: AS4420-1996 (as called up by AS2047-2014)
 Assessed to Standard: AS4420-2016 (as called up by AS2047-2014)

DEFLECTION TEST RESULTS:

Lock Stile: EP14649 (950mm Span)	+ Test Pressure	- Test Pressure
	1508Pa @ L/179	1501Pa @ L/169
	1508Pa @ L/179	1501Pa @ L/169

AIR INFILTRATION RESULTS:

4.22 L/s.m² at 75Pa Positive Test Pressure
 5.20 L/s.m² at 75Pa Negative Test Pressure
Achieved High Air Infiltration Level

OPERATING FORCE RESULTS:

28.0N to initiate movement
 16.0N to sustain movement

ULTIMATE STRENGTH RESULTS:

+ Test Pressure	- Test Pressure
1939Pa	1984Pa

Please read in conjunction with Important Conditions – Index (also available on Capral website)

Test Report Summary

STRUCTURAL & AIR – TEST REPORT NUMBER: C016-014

Performed by: Capral Mechanical Test Laboratory, Victoria – March, 2016
 Test Drawing Number: 31-909

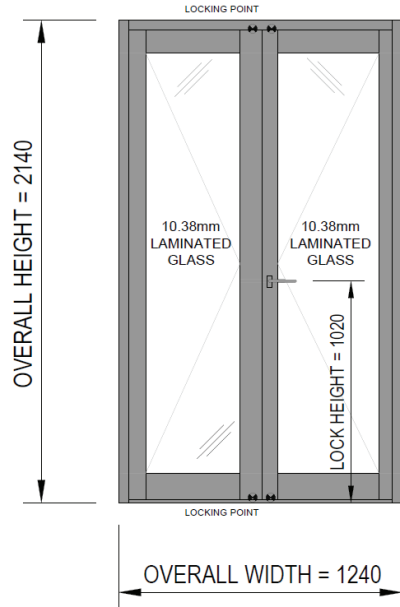

Configuration: Open In French Door into 400 Narrowline – Triple Point Lock
 Glass: 10.38mm Laminated Glass
 Bead / Glazing: Internal Bead / Backing Gasket & Glazing Wedge

Approved to Standard: AS4420-1996 (as called up by AS2047-2014)
 Assessed to Standard: AS4420-2016 (as called up by AS2047-2014)

DEFLECTION TEST RESULTS:

Meeting Stile: EP14649 / EP14649 (2035mm Span)	+ Test Pressure	- Test Pressure
	4006Pa @ L/132 4006Pa @ L/132	4057Pa @ L/124 4057Pa @ L/124

AIR INFILTRATION RESULTS:

4.67 L/s.m² at 75Pa Positive Test Pressure
 4.83 L/s.m² at 75Pa Negative Test Pressure
Achieved High Air Infiltration Level

OPERATING FORCE RESULTS:

28.0N to initiate movement
 16.0N to sustain movement

ULTIMATE STRENGTH RESULTS:

+ Test Pressure	- Test Pressure
5617Pa	5636Pa

Please read in conjunction with Important Conditions – Index (also available on Capral website)

Test Report Summary

STRUCTURAL, AIR & WATER – TEST REPORT NUMBER: C016-015

Performed by: Capral Mechanical Test Laboratory, Victoria – March, 2016

Test Drawing Number: 31-915

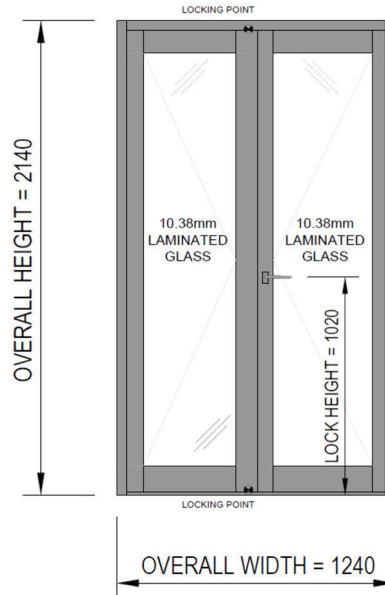

Configuration: Open Out French Door into 400 Narrowline – Single Point Lock
 Glass: 10.38mm Laminated Glass
 Bead / Glazing: Internal Bead / Backing Gasket & Glazing Wedge

Approved to Standard: AS4420-1996 (as called up by AS2047-2014)
 Assessed to Standard: AS4420-2016 (as called up by AS2047-2014)

DEFLECTION TEST RESULTS:

Lock Stile: EP14649 (955mm Span)	+ Test Pressure	- Test Pressure
	1503Pa @ L/231	1508Pa @ L/135
	1503Pa @ L/231	1508Pa @ L/135

AIR INFILTRATION RESULTS:

0.24 L/s.m² at 75Pa Positive Test Pressure *Achieved Low Air Infiltration Level*
 0.62 L/s.m² at 75Pa Negative Test Pressure

WATER PENETRATION RESULTS:

Sill : EP2366 / EP5693 610Pa Pressure for a period of 15mins

OPERATING FORCE RESULTS:

28.0N to initiate movement
 12.5N to sustain movement

ULTIMATE STRENGTH RESULTS:

+ Test Pressure	- Test Pressure
1950Pa	1939Pa

Please read in conjunction with Important Conditions – Index (also available on Capral website)

Test Report Summary

STRUCTURAL, AIR & WATER – TEST REPORT NUMBER: C016-016

Performed by: Capral Mechanical Test Laboratory, Victoria – March, 2016
 Test Drawing Number: 31-915

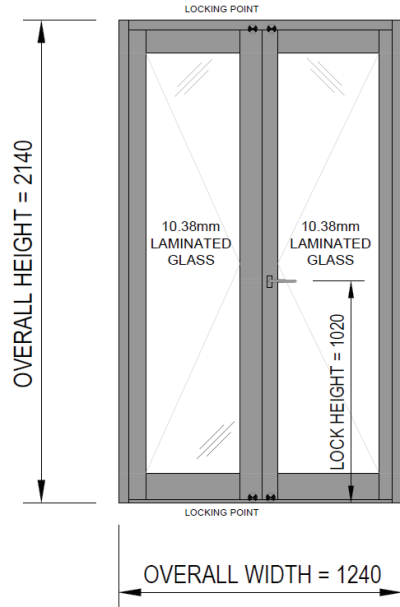

Configuration: Open Out French Door into 400 Narrowline – Triple Point Lock
 Glass: 10.38mm Laminated Glass
 Bead / Glazing: Internal Bead / Backing Gasket & Glazing Wedge

Approved to Standard: AS4420-1996 (as called up by AS2047-2014)
 Assessed to Standard: AS4420-2016 (as called up by AS2047-2014)

DEFLECTION TEST RESULTS:

Meeting Stile: EP14649 / EP14649 (2003mm Span)	+ Test Pressure	- Test Pressure
	4002Pa @ L/132	4000Pa @ L/130
	4002Pa @ L/132	4000Pa @ L/130

AIR INFILTRATION RESULTS:

0.00 L/s.m² at 75Pa Positive Test Pressure
 0.11 L/s.m² at 75Pa Negative Test Pressure
Achieved Low Air Infiltration Level

WATER PENETRATION RESULTS:

Sill : EP2366 / EP5693
 610Pa Pressure for a period of 15mins

OPERATING FORCE RESULTS:

28.0N to initiate movement
 12.5N to sustain movement

ULTIMATE STRENGTH RESULTS:

+ Test Pressure	- Test Pressure
5725Pa	5727Pa

Please read in conjunction with Important Conditions – Index (also available on Capral website)

Test Report Summary

STRUCTURAL, AIR & WATER – TEST REPORT NUMBER: C016-038

Performed by: Capral Mechanical Test Laboratory, Victoria – August, 2016

Test Drawing Number: 31-931

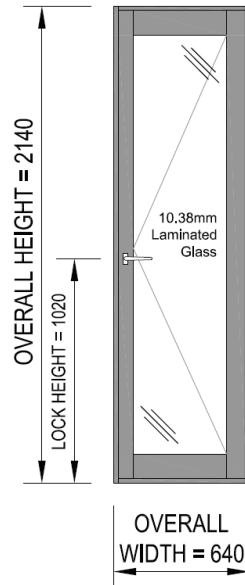

Configuration: Open Out Hinged Door into 400 Narrowline – Single Point Lock
 Glass: 10.38mm Laminated Glass
 Bead / Glazing: Internal Bead / Backing Gasket & Glazing Wedge

Approved to Standard: AS4420-1996 (as called up by AS2047-2014)
 Assessed to Standard: AS4420-2016 (as called up by AS2047-2014)

DEFLECTION TEST RESULTS:

Lock Stile: EP14647 (990mm Span)	+ Test Pressure 3312Pa @ L/697 3312Pa @ L/697	- Test Pressure 3294Pa @ L/106 3294Pa @ L/106
-------------------------------------	---	---

AIR INFILTRATION RESULTS:

0.63 L/s.m² at 75Pa Positive Test Pressure
 4.47 L/s.m² at 75Pa Negative Test Pressure
Achieved High Air Infiltration Level

WATER PENETRATION RESULTS:

Sill : EP13539
 150Pa Pressure for a period of 15mins

OPERATING FORCE RESULTS:

44.5N to initiate movement
 6.5N to sustain movement

ULTIMATE STRENGTH RESULTS:

+ Test Pressure 6095Pa	- Test Pressure 6055Pa
---------------------------	---------------------------

Please read in conjunction with Important Conditions – Index (also available on Capral website)

Test Report Summary

STRUCTURAL & AIR – TEST REPORT NUMBER: C016-039

Performed by: Capral Mechanical Test Laboratory, Victoria – August, 2016
 Test Drawing Number: 31-947

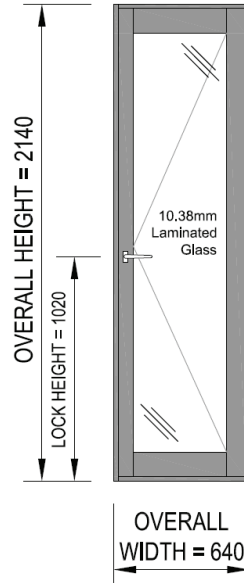

Configuration: Open Out Hinged Door into 400 Narrowline – Single Point Lock
 Glass: 10.38mm Laminated Glass
 Bead / Glazing: Internal Bead / Backing Gasket & Glazing Wedge

Approved to Standard: AS4420-1996 (as called up by AS2047-2014)
 Assessed to Standard: AS4420-2016 (as called up by AS2047-2014)

DEFLECTION TEST RESULTS:

	+ Test Pressure	- Test Pressure
Lock Stile: EP14647	3312Pa @ L/1039	3336Pa @ L/128
(990mm Span)	3312Pa @ L/1039	3336Pa @ L/128

AIR INFILTRATION RESULTS:

2.24 L/s.m² at 75Pa Positive Test Pressure
 8.57 L/s.m² at 75Pa Negative Test Pressure

Achieved High Air Infiltration Level

OPERATING FORCE RESULTS:

39.5N to initiate movement
 13.5N to sustain movement

ULTIMATE STRENGTH RESULTS:

+ Test Pressure	- Test Pressure
6156Pa	6001Pa

Test Report Summary

STRUCTURAL & AIR – TEST REPORT NUMBER: C016-040

Performed by: Capral Mechanical Test Laboratory, Victoria – August, 2016
 Test Drawing Number: 31-947

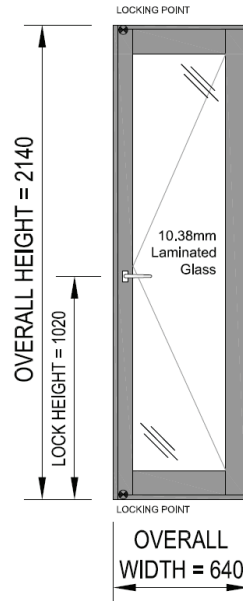

Configuration: Open Out Hinged Door into 400 Narrowline – Triple Point Lock
 Glass: 10.38mm Laminated Glass
 Bead / Glazing: Internal Bead / Backing Gasket & Glazing Wedge

Approved to Standard: AS4420-1996 (as called up by AS2047-2014)
 Assessed to Standard: AS4420-2016 (as called up by AS2047-2014)

DEFLECTION TEST RESULTS:

Lock Stile: EP14647
 (990mm Span)

+ Test Pressure	- Test Pressure
4585Pa @ L/1463	4542Pa @ L/989
4585Pa @ L/1463	4542Pa @ L/989

AIR INFILTRATION RESULTS:

1.96 L/s.m² at 75Pa Positive Test Pressure
 2.10 L/s.m² at 75Pa Negative Test Pressure

Achieved High Air Infiltration Level

ULTIMATE STRENGTH RESULTS:

+ Test Pressure	- Test Pressure
10131Pa	10145Pa

Please read in conjunction with Important Conditions – Index (also available on Capral website)

Test Report Summary

STRUCTURAL, AIR & WATER – TEST REPORT NUMBER: C016-041

Performed by: Capral Mechanical Test Laboratory, Victoria – August, 2016
 Test Drawing Number: 31-948

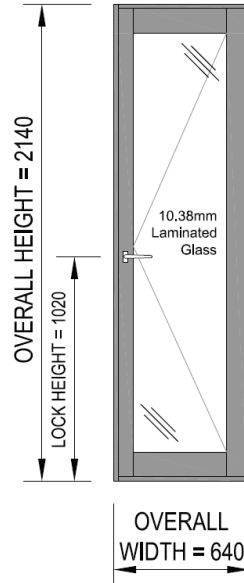

Configuration: Open In Hinged Door into 400 Narrowline – Single Point Lock
 Glass: 10.38mm Laminated Glass
 Bead / Glazing: Internal Bead / Backing Gasket & Glazing Wedge

Approved to Standard: AS4420-1996 (as called up by AS2047-2014)
 Assessed to Standard: AS4420-2016 (as called up by AS2047-2014)

DEFLECTION TEST RESULTS:

Lock Stile: EP14647 (1000mm Span)	+ Test Pressure	- Test Pressure
	3301Pa @ L/108 3301Pa @ L/108	3334Pa @ L/1255 3334Pa @ L/1255

AIR INFILTRATION RESULTS:

3.23 L/s.m² at 75Pa Positive Test Pressure
 3.87 L/s.m² at 75Pa Negative Test Pressure
Achieved High Air Infiltration Level

WATER PENETRATION RESULTS:

Sill : EP15939
 150Pa Pressure for a period of 15mins

OPERATING FORCE RESULTS:

33.5N to initiate movement
 7.0N to sustain movement

Test Report Summary

STRUCTURAL, AIR & WATER – TEST REPORT NUMBER: C016-042

Performed by: Capral Mechanical Test Laboratory, Victoria – August, 2016

Test Drawing Number: 31-948

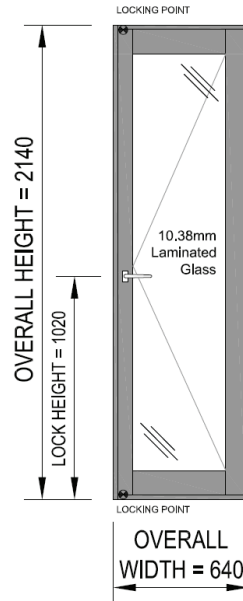

Configuration: Open In Hinged Door into 400 Narrowline – Triple Point Lock
 Glass: 10.38mm Laminated Glass
 Bead / Glazing: Internal Bead / Backing Gasket & Glazing Wedge

Approved to Standard: AS4420-1996 (as called up by AS2047-2014)
 Assessed to Standard: AS4420-2016 (as called up by AS2047-2014)

DEFLECTION TEST RESULTS:

Lock Stile: EP14647
 (1000mm Span)

+ Test Pressure
 4506Pa @ L/784
 4506Pa @ L/784

- Test Pressure
 4526Pa @ L/1521
 4526Pa @ L/1521

AIR INFILTRATION RESULTS:

0.53 L/s.m² at 75Pa Positive Test Pressure
 0.94 L/s.m² at 75Pa Negative Test Pressure

Achieved Low Air Infiltration Level

WATER PENETRATION RESULTS:

Sill : EP15939

151Pa Pressure for a period of 15mins

Test Report Summary

STRUCTURAL, AIR & WATER – TEST REPORT NUMBER: C016-043r

Performed by: Capral Mechanical Test Laboratory, Victoria – August, 2016
 Test Drawing Number: 31-956

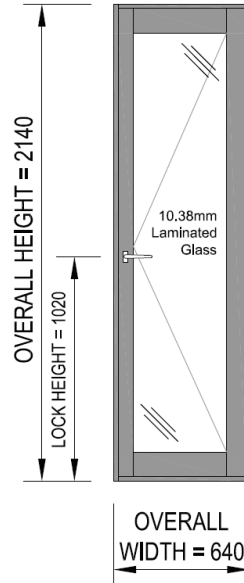

Configuration: Open In Hinged Door into 400 Narrowline – Single Point Lock
 Glass: 10.38mm Laminated Glass
 Bead / Glazing: Internal Bead / Backing Gasket & Glazing Wedge

Approved to Standard: AS4420-1996 (as called up by AS2047-2014)
 Assessed to Standard: AS4420-2016 (as called up by AS2047-2014)

DEFLECTION TEST RESULTS:

Lock Stile: EP14647 (1000mm Span)	+ Test Pressure 3301Pa @ L/108 3301Pa @ L/108	- Test Pressure 3334Pa @ L/1255 3334Pa @ L/1255
--------------------------------------	---	---

AIR INFILTRATION RESULTS:

3.23 L/s.m² at 75Pa Positive Test Pressure
 3.87 L/s.m² at 75Pa Negative Test Pressure
Achieved High Air Infiltration Level

WATER PENETRATION RESULTS:

Sill : EP15939 / EP5693
 206Pa Pressure for a period of 15mins

OPERATING FORCE RESULTS:

33.5N to initiate movement
 7.0N to sustain movement

ULTIMATE STRENGTH RESULTS:

+ Test Pressure 6088Pa	- Test Pressure 6101Pa
---------------------------	---------------------------

Test Report Summary

STRUCTURAL, AIR & WATER – TEST REPORT NUMBER: C016-044

Performed by: Capral Mechanical Test Laboratory, Victoria – August, 2016

Test Drawing Number: 31-956

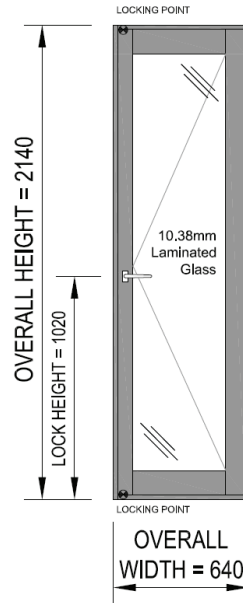

Configuration: Open In Hinged Door into 400 Narrowline – Triple Point Lock
 Glass: 10.38mm Laminated Glass
 Bead / Glazing: Internal Bead / Backing Gasket & Glazing Wedge

Approved to Standard: AS4420-1996 (as called up by AS2047-2014)
 Assessed to Standard: AS4420-2016 (as called up by AS2047-2014)

DEFLECTION TEST RESULTS:

Lock Stile: EP14647
 (1000mm Span)

+ Test Pressure
 4506Pa @ L/784
 4506Pa @ L/784

- Test Pressure
 4526Pa @ L/1521
 4526Pa @ L/1521

AIR INFILTRATION RESULTS:

0.53 L/s.m² at 75Pa Positive Test Pressure
 0.94 L/s.m² at 75Pa Negative Test Pressure

Achieved Low Air Infiltration Level

WATER PENETRATION RESULTS:

Sill : EP15939 / EP5693

302Pa Pressure for a period of 15mins

ULTIMATE STRENGTH RESULTS:

+ Test Pressure
 9553Pa

- Test Pressure
 10014Pa

Test Report Summary

STRUCTURAL, AIR & WATER – TEST REPORT NUMBER: C016-045

Performed by: Capral Mechanical Test Laboratory, Victoria – August, 2016

Test Drawing Number: 31-957

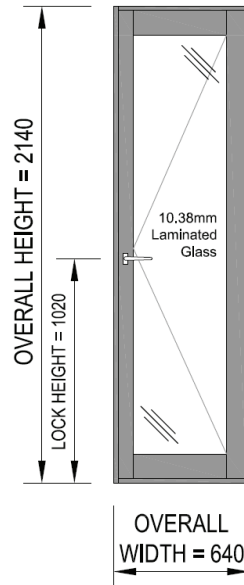

Configuration: Open Out Hinged Door into 400 Narrowline – Single Point Lock
 Glass: 10.38mm Laminated Glass
 Bead / Glazing: Internal Bead / Backing Gasket & Glazing Wedge

Approved to Standard: AS4420-1996 (as called up by AS2047-2014)
 Assessed to Standard: AS4420-2016 (as called up by AS2047-2014)

DEFLECTION TEST RESULTS:

Lock Stile: EP14647 (970mm Span)	+ Test Pressure	- Test Pressure
	3349Pa @ L/2004	3306Pa @ L/109
	3349Pa @ L/2004	3306Pa @ L/109

AIR INFILTRATION RESULTS:

1.30 L/s.m² at 75Pa Positive Test Pressure
 3.87 L/s.m² at 75Pa Negative Test Pressure
Achieved High Air Infiltration Level

WATER PENETRATION RESULTS:

Sill : EP2366 / EP5693
 911Pa Pressure for a period of 15mins

OPERATING FORCE RESULTS:

33.5N to initiate movement
 7.0N to sustain movement

ULTIMATE STRENGTH RESULTS:

+ Test Pressure	- Test Pressure
6137Pa	6046Pa

Test Report Summary

STRUCTURAL, AIR & WATER – TEST REPORT NUMBER: C016-046

Performed by: Capral Mechanical Test Laboratory, Victoria – August, 2016

Test Drawing Number: 31-957

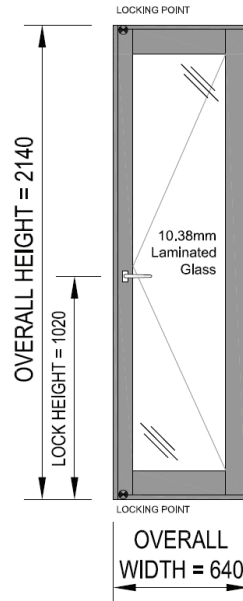

Configuration: Open Out Hinged Door into 400 Narrowline – Triple Point Lock
 Glass: 10.38mm Laminated Glass
 Bead / Glazing: Internal Bead / Backing Gasket & Glazing Wedge

Approved to Standard: AS4420-1996 (as called up by AS2047-2014)
 Assessed to Standard: AS4420-2016 (as called up by AS2047-2014)

DEFLECTION TEST RESULTS:

Lock Stile: EP14647
 (970mm Span)

+ Test Pressure	- Test Pressure
4530Pa @ L/1559	4500Pa @ L/863
4530Pa @ L/1559	4500Pa @ L/863

AIR INFILTRATION RESULTS:

0.10 L/s.m² at 75Pa Positive Test Pressure
 0.20 L/s.m² at 75Pa Negative Test Pressure

Achieved Low Air Infiltration Level

WATER PENETRATION RESULTS:

Sill : EP2366 / EP5693

906Pa Pressure for a period of 15mins

ULTIMATE STRENGTH RESULTS:

+ Test Pressure	- Test Pressure
10310Pa	9305Pa

Please read in conjunction with Important Conditions – Index (also available on Capral website)

Test Report Summary

STRUCTURAL, AIR & WATER – TEST REPORT NUMBER: C016-047

Performed by: Capral Mechanical Test Laboratory, Victoria – September, 2016
 Test Drawing Number: 31-958

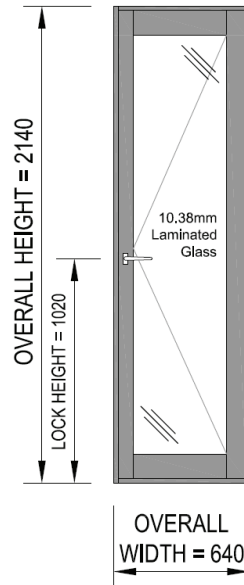

Configuration: Open Out Hinged Door into 400 Narrowline – Single Point Lock
 Glass: 10.38mm Laminated Glass
 Bead / Glazing: Internal Bead / Backing Gasket & Glazing Wedge

Approved to Standard: AS4420-1996 (as called up by AS2047-2014)
 Assessed to Standard: AS4420-2016 (as called up by AS2047-2014)

DEFLECTION TEST RESULTS:

	+ Test Pressure	- Test Pressure
Lock Stile: EP14647	3350Pa @ L/895	3305Pa @ L/113
(960mm Span)	3350Pa @ L/895	3305Pa @ L/113

AIR INFILTRATION RESULTS:

3.09 L/s.m² at 75Pa Positive Test Pressure
 9.08 L/s.m² at 75Pa Negative Test Pressure

Achieved High Air Infiltration Level

WATER PENETRATION RESULTS:

Sill : EP2365

151Pa Pressure for a period of 15mins

OPERATING FORCE RESULTS:

25.0N to initiate movement
 17.5N to sustain movement

Test Report Summary

STRUCTURAL, AIR & WATER – TEST REPORT NUMBER: C016-048

Performed by: Capral Mechanical Test Laboratory, Victoria – September, 2016
 Test Drawing Number: 31-958

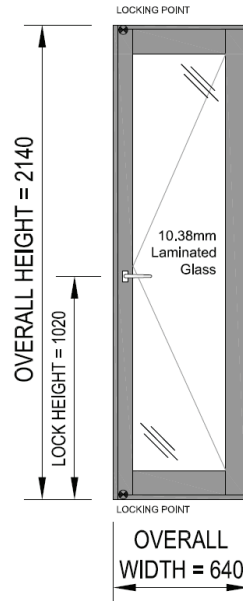

Configuration: Open Out Hinged Door into 400 Narrowline – Triple Point Lock
 Glass: 10.38mm Laminated Glass
 Bead / Glazing: Internal Bead / Backing Gasket & Glazing Wedge

Approved to Standard: AS4420-1996 (as called up by AS2047-2014)
 Assessed to Standard: AS4420-2016 (as called up by AS2047-2014)

DEFLECTION TEST RESULTS:

Lock Stile: EP14647
 (960mm Span)

+ Test Pressure
 4519Pa @ L/1536
 4519Pa @ L/1536

- Test Pressure
 4515Pa @ L/1077
 4515Pa @ L/1077

AIR INFILTRATION RESULTS:

1.44 L/s.m² at 75Pa Positive Test Pressure
 1.90 L/s.m² at 75Pa Negative Test Pressure

Achieved High Air Infiltration Level

WATER PENETRATION RESULTS:

Sill : EP2365

152Pa Pressure for a period of 15mins

Please read in conjunction with Important Conditions – Index (also available on Capral website)

Test Report Summary

STRUCTURAL – TEST REPORT NUMBER: C016-049

Performed by: Capral Mechanical Test Laboratory, Victoria – September, 2016
 Test Drawing Number: 31-959

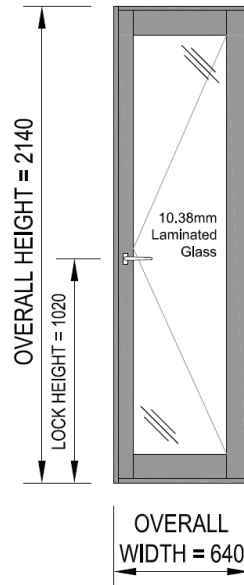

Configuration: Open In Hinged Door into 400 Narrowline – Single Point Lock
 Glass: 10.38mm Laminated Glass
 Bead / Glazing: Internal Bead / Backing Gasket & Glazing Wedge

Approved to Standard: AS4420-1996 (as called up by AS2047-2014)
 Assessed to Standard: AS4420-2016 (as called up by AS2047-2014)

DEFLECTION TEST RESULTS:

	+ Test Pressure	- Test Pressure
Lock Stile: EP14647	3350Pa @ L/895	3305Pa @ L/113
(960mm Span)	3350Pa @ L/895	3305Pa @ L/113

OPERATING FORCE RESULTS:

25.0N to initiate movement
 17.5N to sustain movement

ULTIMATE STRENGTH RESULTS:

+ Test Pressure	- Test Pressure
6088Pa	6007Pa

Test Report Summary

STRUCTURAL, AIR & WATER – TEST REPORT NUMBER: C016-050

Performed by: Capral Mechanical Test Laboratory, Victoria – September, 2016
 Test Drawing Number: 31-959

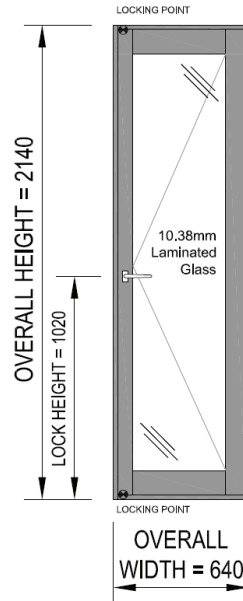

Configuration: Open In Hinged Door into 400 Narrowline – Triple Point Lock
 Glass: 10.38mm Laminated Glass
 Bead / Glazing: Internal Bead / Backing Gasket & Glazing Wedge

Approved to Standard: AS4420-1996 (as called up by AS2047-2014)
 Assessed to Standard: AS4420-2016 (as called up by AS2047-2014)

DEFLECTION TEST RESULTS:

Lock Stile: EP14647
 (960mm Span)

+ Test Pressure	- Test Pressure
4519Pa @ L/1536	4515Pa @ L/1077
4519Pa @ L/1536	4515Pa @ L/1077

AIR INFILTRATION RESULTS:

2.52 L/s.m² at 75Pa Positive Test Pressure
 2.90 L/s.m² at 75Pa Negative Test Pressure

Achieved High Air Infiltration Level

WATER PENETRATION RESULTS:

Sill : EP2365

152Pa Pressure for a period of 15mins

ULTIMATE STRENGTH RESULTS:

+ Test Pressure	- Test Pressure
10014Pa	10080Pa

Please read in conjunction with Important Conditions – Index (also available on Capral website)

Test Report Summary

STRUCTURAL – TEST REPORT NUMBER: C016-052

Performed by: Capral Mechanical Test Laboratory, Victoria – September, 2016
 Test Drawing Number: 31-968

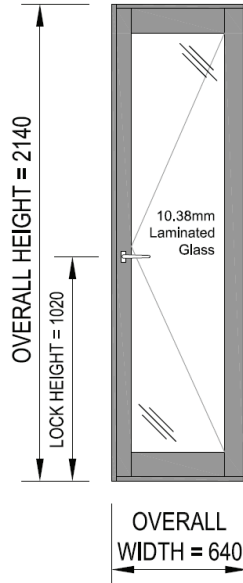

Configuration: Pivot Door into 400 Narrowline
 Glass: 10.38mm Laminated Glass
 Bead / Glazing: Internal Bead / Backing Gasket & Glazing Wedge

Approved to Standard: AS4420-1996 (as called up by AS2047-2014)
 Assessed to Standard: AS4420-2016 (as called up by AS2047-2014)

DEFLECTION TEST RESULTS:

Lock Stile: EP14647
 (2025mm Span)

+ Test Pressure
 4057Pa @ L/139
 4057Pa @ L/139

- Test Pressure
 4011Pa @ L/138
 4011Pa @ L/138

ULTIMATE STRENGTH RESULTS:

+ Test Pressure
 6172Pa

- Test Pressure
 6179Pa

Test Report Summary

STRUCTURAL & AIR – TEST REPORT NUMBER: C017-030

Performed by: Capral Mechanical Test Laboratory, Victoria – November, 2017
 Test Drawing Number: 32-055

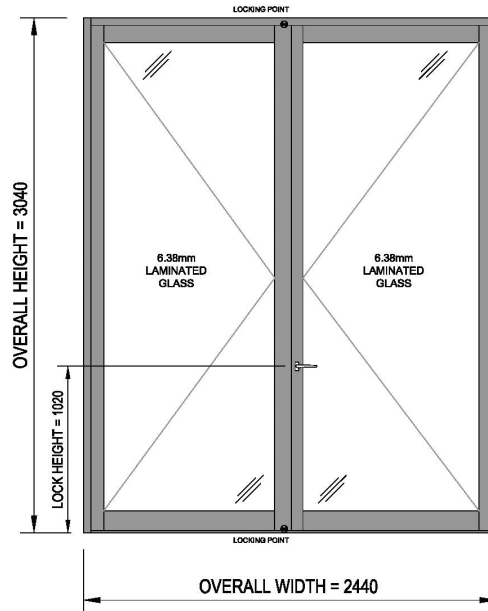

Configuration: Open Out French Door in 400 Narrowline – Single Point Lock
 Glass: 6.38mm Laminated Glass
 Bead / Glazing: Internal Bead, Backing Gasket & Glazing Wedge

Approved to Standard: AS4420.1-2016 (as called up by AS2047-2014)

DEFLECTION TEST RESULTS:

Meeting Stile: EP14649 (2915mm Span)	+ Test Pressure 304Pa @ L/232	- Test Pressure 232Pa @ L/153
Lock Stile: EP14649 (1890mm Span)	304Pa @ L/491	232Pa @ L/110

AIR INFILTRATION RESULTS:

0.28 L/s.m² at 75Pa Positive Test Pressure Achieved High Air Infiltration Level

OPERATING FORCE RESULTS:

16.5N to initiate movement
 12.0N to sustain movement

ULTIMATE STRENGTH RESULTS:

+ Test Pressure 1010Pa	- Test Pressure 307Pa
---------------------------	--------------------------

Please read in conjunction with Important Conditions – Index (also available on Capral website)

Test Report Summary

STRUCTURAL & WATER – TEST REPORT NUMBER: C017-031

Performed by: Capral Mechanical Test Laboratory, Victoria – November, 2017
 Test Drawing Number: 32-055

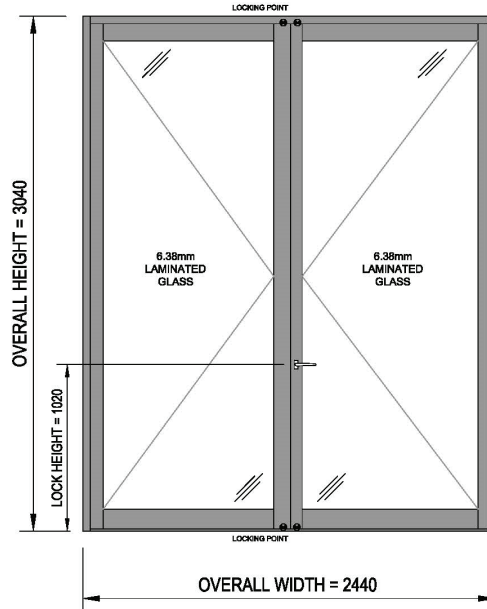

Configuration: Open Out French Door in 400 Narrowline – Triple Point Lock
 Glass: 6.38mm Laminated Glass
 Bead / Glazing: Internal Bead, Backing Gasket & Glazing Wedge

Approved to Standard: AS4420.1-2016 (as called up by AS2047-2014)

DEFLECTION TEST RESULTS:

Meeting Stile: EP14649 / EP14649 (2915mm Span)	+ Test Pressure 705Pa @ L/112	- Test Pressure 703Pa @ L/112
---	----------------------------------	----------------------------------

AIR INFILTRATION RESULTS:

0.27 L/s.m ² at 75Pa Positive Test Pressure	Achieved High Air Infiltration Level
1.06 L/s.m ² at 75Pa Negative Test Pressure	

WATER PENETRATION RESULTS:

Sill: EP2366 / EP5693	307Pa Pressure for a period of 15mins
-----------------------	---------------------------------------

ULTIMATE STRENGTH RESULTS:

+ Test Pressure 1446Pa	- Test Pressure 1400Pa
---------------------------	---------------------------

Test Report Summary

STRUCTURAL – TEST REPORT NUMBER: C017-032

Performed by: Capral Mechanical Test Laboratory, Victoria – November, 2017
 Test Drawing Number: 32-060

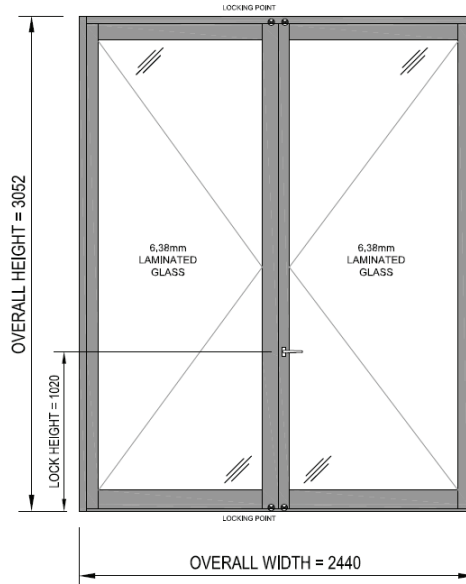

Configuration: Open In French Door in 400 Narrowline – Single Point Lock
 Glass: 6.38mm Laminated Glass
 Bead / Glazing: Internal Bead, Backing Gasket & Glazing Wedge

Approved to Standard: AS4420.1-2016 (as called up by AS2047-2014)

DEFLECTION TEST RESULTS:

	+ Test Pressure	- Test Pressure
Meeting Stile: EP14649 (2942mm Span)	181Pa @ L/198	304Pa @ L/238
Lock Stile: EP14649 (1955mm Span)	120Pa @ L/136	304Pa @ L/445

OPERATING FORCE RESULTS:

31.0N to initiate movement
 3.0N to sustain movement

ULTIMATE STRENGTH RESULTS:

+ Test Pressure	- Test Pressure
532Pa	538Pa

Please read in conjunction with Important Conditions – Index (also available on Capral website)

Test Report Summary

STRUCTURAL, AIR & WATER – TEST REPORT NUMBER: C017-033

Performed by: Capral Mechanical Test Laboratory, Victoria – November, 2017
 Test Drawing Number: 32-060

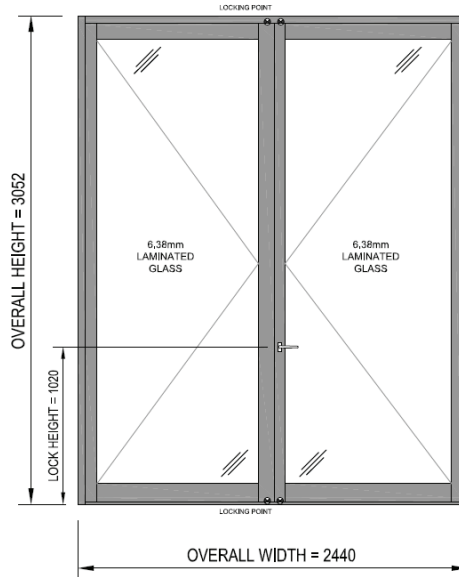

Configuration: Open In French Door in 400 Narrowline – Triple Point Lock
 Glass: 6.38mm Laminated Glass
 Bead / Glazing: Internal Bead, Backing Gasket & Glazing Wedge

Approved to Standard: AS4420.1-2016 (as called up by AS2047-2014)

DEFLECTION TEST RESULTS:

Meeting Stile: EP14649 / EP14649
 (2942mm Span)

+ Test Pressure
 701Pa @ L/114

- Test Pressure
 710Pa @ L/109

AIR INFILTRATION RESULTS:

1.08 L/s.m² at 75Pa Positive Test Pressure
 0.21 L/s.m² at 75Pa Negative Test Pressure

Achieved High Air Infiltration Level

WATER PENETRATION RESULTS:

Sill : EP15939 / EP5693 (installed not used)

151Pa Pressure for a period of 15mins

ULTIMATE STRENGTH RESULTS:

+ Test Pressure
 1441Pa

- Test Pressure
 1444Pa

Test Report Summary

AIR & WATER – TEST REPORT NUMBER: C017-034

Performed by: Capral Mechanical Test Laboratory, Victoria – January, 2018

Test Drawing Number: 32-060

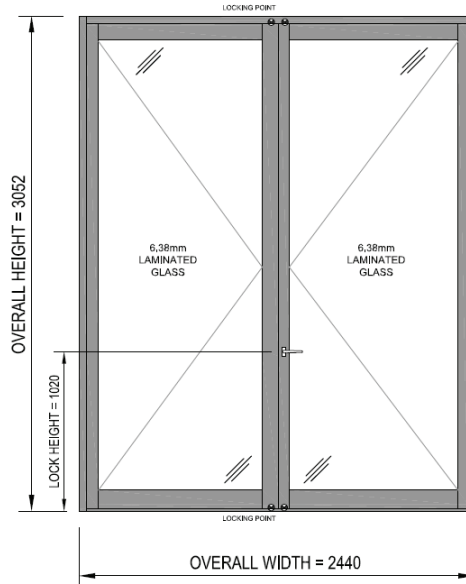

Configuration: Open In French Door in 400 Narrowline with Sub Sill– Triple Point Lock
 Glass: 6.38mm Laminated Glass
 Bead / Glazing: Internal Bead, Backing Gasket & Glazing Wedge

Approved to Standard: AS4420.1-2016 (as called up by AS2047-2014)

AIR INFILTRATION RESULTS:

0.97 L/s.m² at 75Pa Positive Test Pressure
 0.98 L/s.m² at 75Pa Negative Test Pressure

Achieved Low Air Infiltration Level

WATER PENETRATION RESULTS:

Sill : EP15939 / EP5693

203Pa Pressure for a period of 15mins

Test Report Summary

STRUCTURAL & WATER – TEST REPORT NUMBER: C020-002A

Performed by: Capral Mechanical Test Laboratory, Victoria – April, 2020
 Test Drawing Number: 32-231

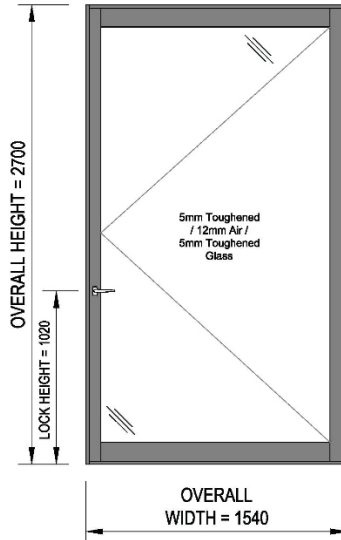

Configuration: Open Out Hinged Door in 601 Narrowline – Single Point Lock (Commercial Spigots)
 Glass: 5mm Toughened / 12mm / 5mm Toughened Glass
 Bead / Glazing: External Bead, Backing Gasket & Glazing Wedge

Approved to Standard: AS4420.1-2016 (as called up by AS2047-2014)

DEFLECTION TEST RESULTS:

Lock Stile: EP14893
 (1500mm Span)

+ Test Pressure
 456Pa @ L/1348

- Test Pressure
 322Pa @ L/103

OPERATING FORCE RESULTS:

12.0N to initiate movement
 8.5N to sustain movement

WATER PENETRATION RESULTS:

Sill : EP5796 / EP5328

463Pa Pressure for a period of 15mins

ULTIMATE STRENGTH RESULTS:

+ Test Pressure
 1232Pa

- Test Pressure
 1005Pa

Test Report Summary

STRUCTURAL & WATER – TEST REPORT NUMBER: C020-003A

Performed by: Capral Mechanical Test Laboratory, Victoria – April, 2020
 Test Drawing Number: 32-239

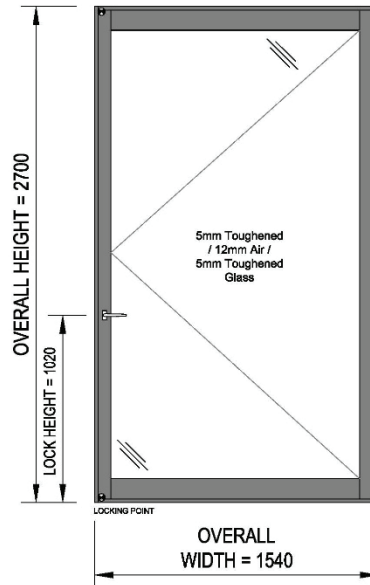

Configuration: Open Out Hinged Door in 601 Narrowline – Triple Point Lock (Commercial Spigots)
 Glass: 5mm Toughened / 12mm / 5mm Toughened Glass
 Bead / Glazing: External Bead, Backing Gasket & Glazing Wedge

Approved to Standard: AS4420.1-2016 (as called up by AS2047-2014)

DEFLECTION TEST RESULTS:

Lock Stile: EP14893
 (1500mm Span)

+ Test Pressure
 3305Pa @ L/533

- Test Pressure
 3306Pa @ L/167

WATER PENETRATION RESULTS:

Sill : EP5796 / EP5328

451Pa Pressure for a period of 15mins

ULTIMATE STRENGTH RESULTS:

+ Test Pressure
 3962Pa

- Test Pressure
 3125Pa

Please read in conjunction with Important Conditions – Index (also available on Capral website)

Test Report Summary

CYCLONIC IMPACT TESTING - TEST REPORT NUMBER: AZT0420.17

Performed by: Azuma Design Pty Ltd, Sydney - October, 2017

Test Drawing Number: 31-975

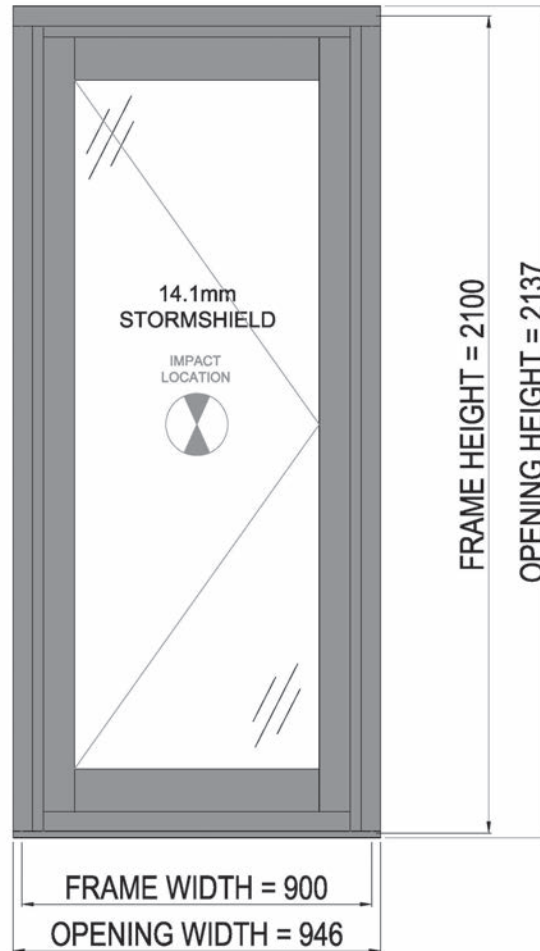

Configuration: 225 Hinged Door (TPL) in Sub Frame
 Glass: 14.1mm Stormshield Glass
 Glazing: Wet Glazed

Results are on an "observe and report" basis only as compliance criteria is not clearly specified in AS1170

Major Impact

Impactor: 100mm x 50mm Hardwood projectile of mass 4.00kg

Impact Speed: 44.0m/s

Impact Location: At centre of glass

Result: The impactor failed to penetrate the sample.

Minor Impacts

Impactor: 8mm steel ball of mass 2.00 grams

Impact Speed: 5 impacts at 44.0m/s

Impact Location: At random locations on the glass

Result: All impacts failed to penetrate the sample.

Test Report Summary

CYCLONIC IMPACT TESTING - TEST REPORT NUMBER: AZT0421.18

Performed by: Azuma Design Pty Ltd, Sydney - September, 2018

Test Drawing Number: 32-067

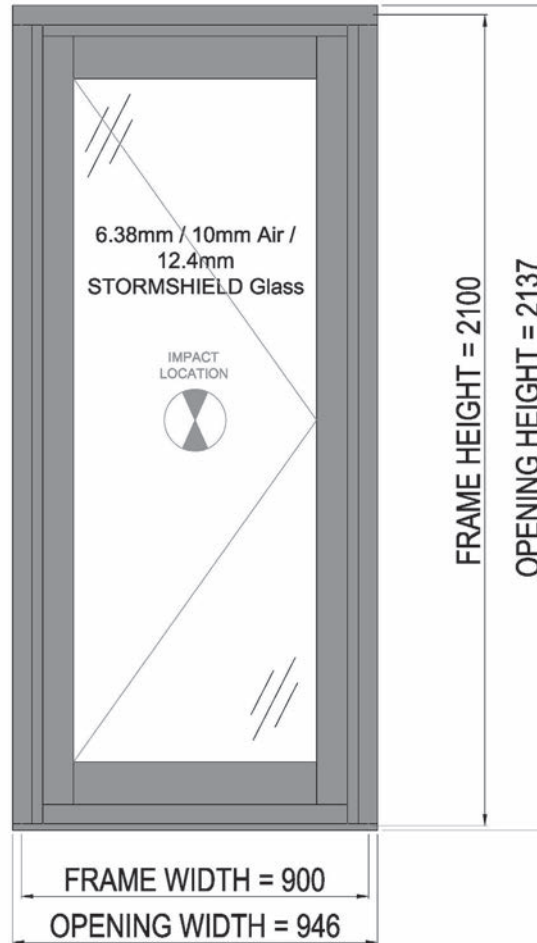

Configuration: 225 Hinged Door (TPL) in Sub Frame
 Glass: 6.38mm Laminate / 10mm Air / 12.4mm Stormshield Glass
 Glazing: Wet Glazed

Results are on an "observe and report" basis only as compliance criteria is not clearly specified in AS1170

Major Impact

Impactor: 100mm x 50mm Hardwood projectile of mass 4.00kg

Impact Speed: 38.0m/s

Impact Location: At centre of glass

Result: The impactor failed to penetrate the sample.

Minor Impacts

Impactor: 8mm steel ball of mass 2.00 grams

Impact Speed: 5 impacts at 38.0m/s

Impact Location: At random locations on the glass

Result: All impacts failed to penetrate the sample.

Test Report Summary

CYCLONIC IMPACT TESTING - TEST REPORT NUMBER: AZT0422.18

Performed by: Azuma Design Pty Ltd, Sydney - September, 2018

Test Drawing Number: 32-068

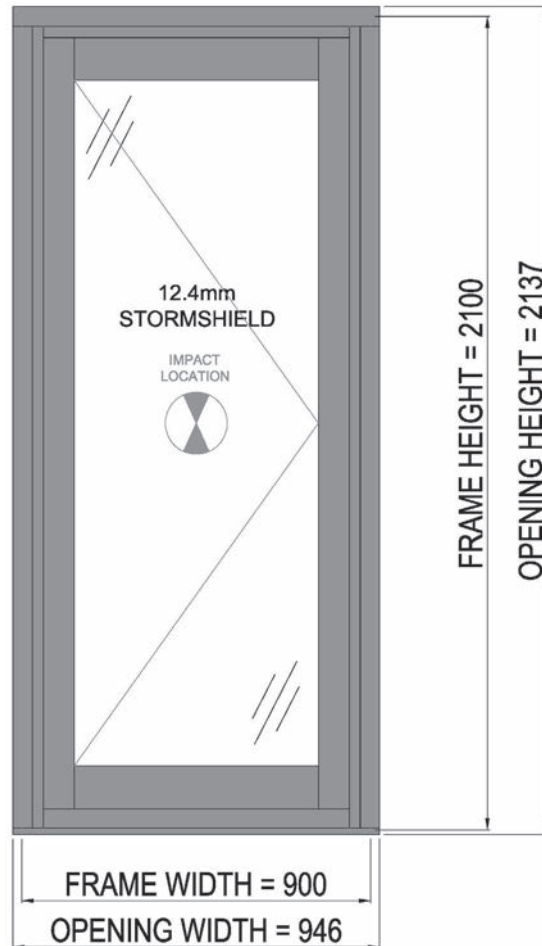

Configuration: 225 Hinged Door (TPL) in Sub Frame
 Glass: 12.4mm Stormshield Glass
 Glazing: Wet Glazed

Results are on an "observe and report" basis only as compliance criteria is not clearly specified in AS1170

Major Impact

Impactor: 100mm x 50mm Hardwood projectile of mass 4.00kg

Impact Speed: 38.0m/s

Impact Location: At centre of glass

Result: The impactor failed to penetrate the sample.

Minor Impacts

Impactor: 8mm steel ball of mass 2.00 grams

Impact Speed: 5 impacts at 38.0m/s

Impact Location: At random locations on the glass

Result: All impacts failed to penetrate the sample.

Test Report Summary

CYCLIC TESTING – HINGED DOOR: C020-100

Performed by: Capral Mechanical Test Laboratory, Victoria – April, 2020

Test Drawing Number: 32-231

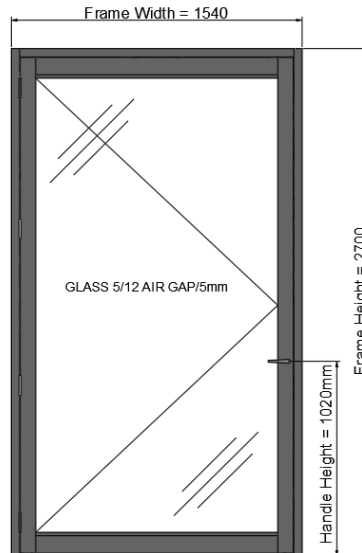

Configuration: Open Out Single Door into 601 Narrowline
 Glass: 5mm / 12mm / 5mm Double Glazed
 Bead / Glazing: Internal Bead / Backing Gasket & Glazing Wedge
 Corner Spigots: Aluminum Commercial (322182)
 Glass Support Method: Glass Heal & Toe Blocks (322233)

TEST METHOD:

An electric repetition apparatus was used to continually to open and close the door. The connection between the apparatus and the door allowed the door to swing open and fully close against the door stop. At the commencement of testing measurements of the clearance between the door panel and door frame were recorded, these measurements were then repeated at regular intervals throughout the testing.

TEST RESULT:

The test was terminated after 1,000,000 cycles and the door panel inspected with the following observations.

- No evidence of top or bottom rails drop was observed all joints sturdy and intact.
- The glass support method (322233) were in place in their installed locations and there was no evidence of glass drop.
- The clearance between the door panel and door frame was found to be consistent throughout the test.

Test Report Summary

CYCLIC TESTING – HINGED DOOR: 3001-001 (File Number 2012003-2)

Performed by: Assa Abloy Test Laboratory Rocklea Queensland – January 2012

Test Drawing Number: 31-535

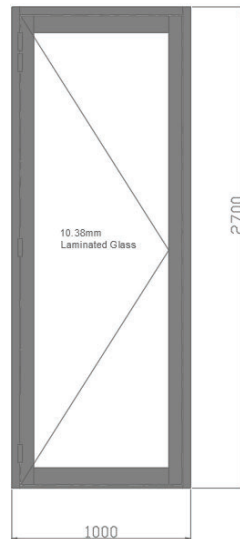

Configuration: Open Out Single Door into 400 Narrowline

Glass: 10.38mm Laminate

Bead / Glazing: Internal Bead / Glazing Wedge & Glazing Wedge

Corner Spigots: Euro Spigot (315483)

Glass Support Method: Glass Jacking Screw, Pressed Nut & Foot (315482 / 315486 / 315487)

TEST METHOD:

Pneumatic actuators and control were utilised to continually open and slam the door closed. The connection between the pneumatic cylinder and the angle bracket on the test door, allowed the test door to freely swing shut for the last 20mm of closing travel until slamming against the door stop.

TEST RESULT:

The test was terminated after 1,000,000 cycles and the /door panel inspected.

- No evidence of top or bottom rail drop was observed all joints sturdy and intact.
- There was no evidence of glass drop.

Test Report Summary

BAL 40 BUSHFIRE TESTING - TEST REPORT NUMBER: 44400500.1
- ASSESSMENT REPORT: 52627900.1a

Performed by: Exova Warringtonfire, Victoria – March, 2017
 Test Drawing Number: 31-920

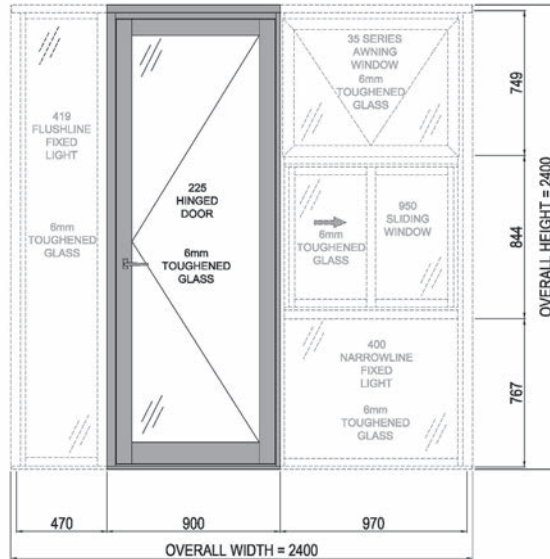

Door Configuration:	Open Out 225 Entry Door – 46mm Panels
Sash Glazing Wedge:	Wedge – 306916
Sash Back Gasket:	306905
Door Perimeter Seal:	Duoseal Door Stop - 300022
Lock / Hinge Stile Seal:	11mm Polypile - 301865
Lock:	Optimum 4 point Mortice Lock - 315502

Approved to Standard: AS1530.8.1 – 2018

Reference 16.9.2(b) of AS1530.8.1 – 2018: "Where single glazing is tested, the glazing may be the same or thicker glazing of the same type and the glazing may be multiple glazing where the fire side pane is the same or thicker than tested."

TEST RESULTS:

Performance Criteria	Time to Failure (min)	Position of Failure
Formation of through-gaps greater than 3mm.	No Failure	-
Sustained failure for 10sec. on the non-fire side.	No Failure	-
Flaming on the fire –exposed side at the end of the 60min. test period.	No Failure	-
Radiant heat flux 365mm from the non-fire exposed side exceeding 15kW/m ² .	No Failure	-
Mean and maximum temperature rises greater than 140K & 180K.	No applicable for glazed elements.	-
Radiant heat flux 250mm from the specimen, greater than 3kW/m ² between 20mins. and 60mins.	No Failure	-
Mean and maximum temperature of internal faces exceeding 250°C and 300°C respectively between 20mins. and 60mins. after commencement of test.	Not applicable for glazed elements.	-
Crib Class	A	Peak Heat Flux
Test Result	BAL-A40	
		40 kW/m²

Please read in conjunction with Important Conditions – Index (also available on Capral website)

Test Report Summary

BAL 40 BUSHFIRE TESTING - TEST REPORT NUMBER: 44400500.1
- ASSESSMENT REPORT: 52627900.1a

Performed by: Exova Warringtonfire, Victoria – March, 2017
 Test Drawing Number: 32-268

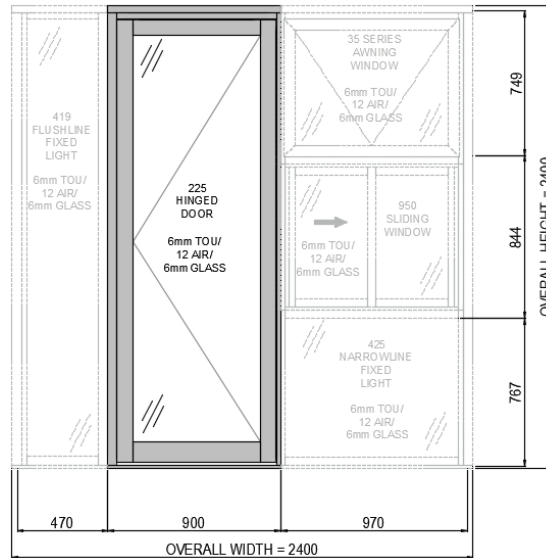

Door Configuration:	Open Out 225 Entry Door – 46mm Panels
Sash Glazing Wedge:	Wedge – 306905
Sash Back Gasket:	306909
Door Perimeter Seal:	Duoseal Door Stop - 300022
Lock / Hinge Stile Seal:	11mm Polypile - 301865
Lock:	Optimum 4 point Mortice Lock - 315502

Approved to Standard: AS1530.8.1 – 2018

Reference 16.9.2(b) of AS1530.8.1 – 2018: "Where single glazing is tested, the glazing may be the same or thicker glazing of the same type and the glazing may be multiple glazing where the fire side pane is the same or thicker than tested."

TEST RESULTS:

Performance Criteria	Time to Failure (min)	Position of Failure
Formation of through-gaps greater than 3mm.	No Failure	-
Sustained failure for 10sec. on the non-fire side.	No Failure	-
Flaming on the fire –exposed side at the end of the 60min. test period.	No Failure	-
Radiant heat flux 365mm from the non-fire exposed side exceeding 15kW/m ² .	No Failure	-
Mean and maximum temperature rises greater than 140K & 180K.	No applicable for glazed elements.	-
Radiant heat flux 250mm from the specimen, greater than 3kW/m ² between 20mins. and 60mins.	No Failure	-
Mean and maximum temperature of internal faces exceeding 250°C and 300°C respectively between 20mins. and 60mins. after commencement of test.	Not applicable for glazed elements.	-
Crib Class	A	Peak Heat Flux
		40 kW/m²
Test Result		BAL-A40

Please read in conjunction with Important Conditions – Index (also available on Capral website)

Test Report Summary

ACOUSTIC

Performed by: Commonwealth Scientific and Industrial Research Organisation (CSIRO), Clayton Victoria – November, 2017

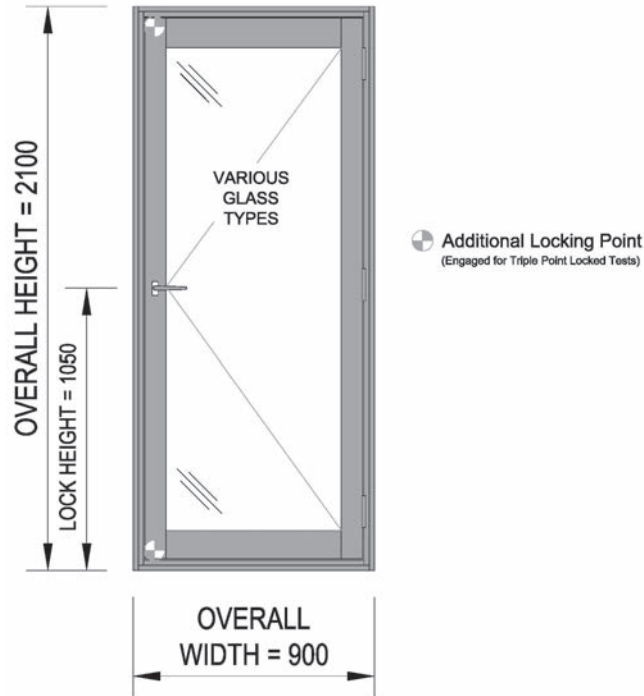

Configuration: D

Framing System: Open Out Hinged Door in 400 Narrowline Frame

Approved to Standard: AS1191-2002 & AS1276.1-1999

TEST REPORT NUMBER: TL620-29-1

Test Drawing Number: 31-942

TEST SAMPLE DETAILS:

- Glass: 5mm Clear Float
- Locking: Single Point Locked
- Glazing: 4mm Backing Gasket (306905) & 7mm Glazing Wedge (306909)
- Door Seals: 5mm Duoseal Door Stop (300022)

SOUND INSULATION RATING:

Rw (C;Ctr): 27 (0;0)

TEST REPORT NUMBER: TL620-20-1

Test Drawing Number: 31-942

TEST SAMPLE DETAILS:

- Glass: 5mm Clear Float
- Locking: Triple Point Locked
- Glazing: 4mm Backing Gasket (306905) & 7mm Glazing Wedge (306909)
- Door Seals: 5mm Duoseal Door Stop (300022)

SOUND INSULATION RATING:

Rw (C;Ctr): 30 (-1;-1)

Please read in conjunction with Important Conditions – Index (also available on Capral website)

Test Report Summary

TEST REPORT NUMBER: TL620-32-1

Test Drawing Number: 31-942

TEST SAMPLE DETAILS:

Glass: 6.38mm Clear Laminate
Locking: Single Point Locked
Glazing: 4mm Backing Gasket (306905) & 6mm Glazing Wedge (306916)
Door Seals: 5mm Duoseal Door Stop (300022)

SOUND INSULATION RATING:

Rw (C;Ctr): 30 (-1;-1)

TEST REPORT NUMBER: TL620-34-1

Test Drawing Number: 31-942

TEST SAMPLE DETAILS:

Glass: 10.38mm Clear Laminate
Locking: Single Point Locked
Glazing: 1.2mm Backing Gasket (306908) & 5mm Glazing Wedge (306914)
Door Seals: 5mm Duoseal Door Stop (300022)

SOUND INSULATION RATING:

Rw (C;Ctr): 31 (0;-1)

TEST REPORT NUMBER: TL620-21-1

Test Drawing Number: 31-942

TEST SAMPLE DETAILS:

Glass: 10.50mm Clear HUSH Laminate
Locking: Single Point Locked
Glazing: 1.2mm Backing Gasket (306908) & 5mm Glazing Wedge (306914)
Door Seals: 5mm Duoseal Door Stop (300022)

SOUND INSULATION RATING:

Rw (C;Ctr): 31 (-1;-1)

TEST REPORT NUMBER: TL620-22-1

Test Drawing Number: 31-942

TEST SAMPLE DETAILS:

Glass: 10.50mm Clear HUSH Laminate
Locking: Triple Point Locked
Glazing: 1.2mm Backing Gasket (306908) & 5mm Glazing Wedge (306914)
Door Seals: 5mm Duoseal Door Stop (300022)

SOUND INSULATION RATING:

Rw (C;Ctr): 34 (0;-1)

Test Report Summary

TEST REPORT NUMBER: TL620-30-1

Test Drawing Number: 31-943

TEST SAMPLE DETAILS:

Glass: 6mm Clear Float / 12mm Argon / 6mm Clear Float
Locking: Single Point Locked
Glazing: 4mm Backing Gasket (306905) & 7mm Glazing Wedge (306909)
Door Seals: 5mm Duoseal Door Stop (300022)

SOUND INSULATION RATING:

Rw (C;Ctr): 33 (-1;-2)

TEST REPORT NUMBER: TL620-31-1

Test Drawing Number: 31-943

TEST SAMPLE DETAILS:

Glass: 6mm Clear Float / 12mm Argon / 6mm Clear Float
Locking: Triple Point Locked
Glazing: 4mm Backing Gasket (306905) & 7mm Glazing Wedge (306909)
Door Seals: 5mm Duoseal Door Stop (300022)

SOUND INSULATION RATING:

Rw (C;Ctr): 34 (-1;-2)

TEST REPORT NUMBER: TL620-25-1

Test Drawing Number: 31-943

TEST SAMPLE DETAILS:

Glass: 6mm Clear Float / 12mm Argon / 6.50mm Clear HUSH Laminate
Locking: Single Point Locked
Glazing: 4mm Backing Gasket (306905) & 7mm Glazing Wedge (306909)
Door Seals: 5mm Duoseal Door Stop (300022)

SOUND INSULATION RATING:

Rw (C;Ctr): 35 (-1;-2)

TEST REPORT NUMBER: TL620-28-1

Test Drawing Number: 31-943

TEST SAMPLE DETAILS:

Glass: 6mm Clear Float / 12mm Argon / 10.38mm Clear Laminate
Locking: Single Point Locked
Glazing: 4mm Backing Gasket (306905) & 3mm Glazing Wedge (306910)
Door Seals: 5mm Duoseal Door Stop (300022)

SOUND INSULATION RATING:

Rw (C;Ctr): 33 (0;-1)

Test Report Summary

TEST REPORT NUMBER: TL620-27-1

Test Drawing Number: 31-943

TEST SAMPLE DETAILS:

Glass: 6mm Clear Float / 12mm Argon / 10.50mm Clear HUSH Laminate
Locking: Single Point Locked
Glazing: 4mm Backing Gasket (306905) & 3mm Glazing Wedge (306910)
Door Seals: 5mm Duoseal Door Stop (300022)

SOUND INSULATION RATING:

Rw (C;Ctr): 31 (-1;-1)

TEST REPORT NUMBER: TL620-26-1

Test Drawing Number: 31-943

TEST SAMPLE DETAILS:

Glass: 6mm Clear Float / 12mm Argon / 10.50mm Clear HUSH Laminate
Locking: Triple Point Locked
Glazing: 4mm Backing Gasket (306905) & 3mm Glazing Wedge (306910)
Door Seals: 5mm Duoseal Door Stop (300022)

SOUND INSULATION RATING:

Rw (C;Ctr): 36 (-1;-2)

Span Table

LOCK STILE - SINGLE LOCKING POINT - EP14647 (EP14893 SIMILAR)

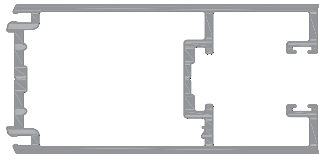

Note:

Serviceability pressures have been limited to a maximum pressure of 3300Pa.

Serviceability pressures have not been limited by water performance. Where water performance is necessary, refer to Product Specification page.

This table has been based on a lock height of 1050mm.

Figures in Italics achieved using 322182 / 322183 Spigots.

Sash Height (mm)		Maximum Design Pressure (kPa)									
3000	S (L/100)	0.524	0.449	-	-	-	-	-	-	-	-
	U	1.754	1.503	-	-	-	-	-	-	-	-
2950	S (L/100)	0.566	0.485	0.424	-	-	-	-	-	-	-
	U	1.847	1.583	1.386	-	-	-	-	-	-	-
2900	S (L/100)	0.613	0.526	0.460	0.409	-	-	-	-	-	-
	U	1.949	1.670	1.461	1.299	-	-	-	-	-	-
2850	S (L/100)	0.666	0.571	0.499	0.444	-	-	-	-	-	-
	U	2.058	1.764	1.544	1.372	-	-	-	-	-	-
2800	S (L/100)	0.724	0.621	0.543	0.483	0.435	-	-	-	-	-
	U	2.178	1.867	1.633	1.452	1.307	-	-	-	-	-
2750	S (L/100)	0.790	0.677	0.593	0.527	0.474	0.431	-	-	-	-
	U	2.308	1.978	1.731	1.538	1.385	1.259	-	-	-	-
2700	S (L/100)	0.864	0.741	0.648	0.576	0.519	0.471	0.432	-	-	-
	U	2.450	2.100	1.837	1.633	1.470	1.336	1.225	-	-	-
2650	S (L/100)	0.948	0.812	0.711	0.632	0.569	0.517	0.474	0.437	0.406	-
	U	2.605	2.233	1.954	1.737	1.563	1.421	1.303	1.202	1.116	-
2600	S (L/100)	1.043	0.894	0.782	0.695	0.626	0.569	0.521	0.481	0.447	0.417
	U	2.776	2.379	2.082	1.851	1.666	1.514	1.388	1.281	1.190	1.110
2550	S (L/100)	1.150	0.986	0.863	0.767	0.690	0.627	0.575	0.531	0.493	0.460
	U	2.964	2.541	2.223	1.976	1.778	1.617	1.482	1.368	1.270	1.186
2500	S (L/100)	1.273	1.091	0.955	0.849	0.764	0.695	0.637	0.588	0.546	0.509
	U	3.172	2.719	2.379	2.115	1.903	1.730	1.586	1.464	1.359	1.269
2450	S (L/100)	1.415	1.213	1.061	0.943	0.849	0.772	0.707	0.653	0.606	0.566
	U	3.403	2.916	2.552	2.268	2.042	1.856	1.701	1.570	1.458	1.361
2400	S (L/100)	1.578	1.352	1.183	1.052	0.947	0.861	0.789	0.728	0.676	0.631
	U	3.659	3.137	2.744	2.440	2.196	1.996	1.830	1.689	1.568	1.464
2350	S (L/100)	1.767	1.515	1.325	1.178	1.060	0.964	0.884	0.816	0.757	0.707
	U	3.946	3.382	2.960	2.631	2.368	2.152	1.973	1.821	1.691	1.578
2300	S (L/100)	1.988	1.704	1.491	1.325	1.193	1.084	0.994	0.917	0.852	0.795
	U	4.268	3.658	3.201	2.845	2.561	2.328	2.134	1.970	1.829	1.707
2250	S (L/100)	2.247	1.926	1.685	1.498	1.348	1.225	1.123	1.037	0.963	0.899
	U	4.631	3.970	3.473	3.088	2.779	2.526	2.316	2.138	1.985	1.853
2200	S (L/100)	2.553	2.188	1.914	1.702	1.532	1.392	1.276	1.178	1.094	1.021
	U	5.043	4.322	3.782	3.362	3.026	2.751	2.521	2.327	2.161	2.017
2150	S (L/100)	2.917	2.500	2.188	1.944	1.750	1.591	1.458	1.346	1.250	1.167
	U	5.512	4.724	4.134	3.674	3.307	3.006	2.756	2.544	2.362	2.205
2100	S (L/100)	3.300	2.874	2.515	2.236	2.012	1.829	1.677	1.548	1.437	1.341
	U	6.049	5.185	4.537	4.033	3.629	3.299	3.024	2.792	2.592	2.420
Sash Width (mm)		600	700	800	900	1000	1100	1200	1300	1400	1500

LEGEND: S = Serviceability Pressure, U = Ultimate Pressure

NOTE: This table is based on a combination of approved AS2047 testing data and theoretical section properties.

A maximum stress level of 110MPa has been applied when generating this table.

Span Table

LOCK STILE - TRIPLE LOCKING POINTS - EP14647 (EP14893 SIMILAR)

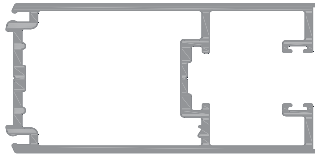

Note:

Serviceability pressures have been limited to a maximum pressure of 4500Pa.

Serviceability pressures have not been limited by water performance. Where water performance is necessary, refer to Product Specification page.

This table has been based on a lock height of 1050mm.

Figures in *Italics* achieved using 322182 / 322183 Spigots.

Sash Height (mm)		Maximum Design Pressure (kPa)									
3000	S (L/100)	4.500	4.308	3.770	3.351	3.016	2.742	2.513	2.320	2.154	2.010
	U	7.015	6.013	5.262	4.677	4.209	3.827	3.508	3.200	3.007	2.806
2950	S (L/100)	4.500	4.500	4.075	3.622	3.260	2.964	2.717	2.508	2.329	2.173
	U	7.389	6.334	5.542	4.926	4.434	4.031	3.695	3.200	3.167	2.956
2900	S (L/100)	4.500	4.500	4.415	3.924	3.532	3.211	2.943	2.717	2.523	2.354
	U	7.794	6.681	5.846	5.196	4.677	4.251	3.897	3.200	3.200	3.118
2850	S (L/100)	4.500	4.500	4.500	4.260	3.834	3.486	3.195	2.949	2.739	2.556
	U	8.233	7.057	6.175	5.489	4.940	4.491	4.117	3.200	3.200	3.200
2800	S (L/100)	4.500	4.500	4.500	4.500	4.172	3.793	3.477	3.100	2.980	2.782
	U	8.711	7.466	6.533	5.807	5.226	4.751	4.355	3.200	3.200	3.200
2750	S (L/100)	4.500	4.500	4.500	4.500	4.500	4.138	3.793	3.100	3.100	3.034
	U	9.230	7.912	6.923	6.154	5.538	5.035	4.615	3.200	3.200	3.200
2700	S (L/100)	4.500	4.500	4.500	4.500	4.500	4.500	4.148	3.100	3.100	3.100
	U	9.798	8.399	7.349	6.532	5.879	5.345	4.899	3.200	3.200	3.200
2650	S (L/100)	4.500	4.500	4.500	4.500	4.500	4.500	4.500	3.100	3.100	3.100
	U	10.000	8.932	7.815	6.947	6.252	5.684	5.210	3.200	3.200	3.200
2600	S (L/100)	4.500	4.500	4.500	4.500	4.500	4.500	4.500	3.100	3.100	3.100
	U	10.000	9.517	8.328	7.402	6.662	6.056	5.552	3.200	3.200	3.200
2550	S (L/100)	4.500	4.500	4.500	4.500	4.500	4.500	4.500	3.100	3.100	3.100
	U	10.000	10.000	8.892	7.904	7.114	6.467	5.928	3.200	3.200	3.200
2500	S (L/100)	4.500	4.500	4.500	4.500	4.500	4.500	4.500	3.100	3.100	3.100
	U	10.000	10.000	9.516	8.459	7.613	6.921	6.344	3.200	3.200	3.200
2450	S (L/100)	4.500	4.500	4.500	4.500	4.500	4.500	4.500	3.100	3.100	3.100
	U	10.000	10.000	10.000	9.073	8.166	7.424	6.805	3.200	3.200	3.200
2400	S (L/100)	4.500	4.500	4.500	4.500	4.500	4.500	4.500	3.100	3.100	3.100
	U	10.000	10.000	10.000	9.758	8.782	7.984	7.319	3.200	3.200	3.200
2350	S (L/100)	4.500	4.500	4.500	4.500	4.500	4.500	4.500	3.100	3.100	3.100
	U	10.000	10.000	10.000	10.000	9.471	8.610	7.892	3.200	3.200	3.200
2300	S (L/100)	4.500	4.500	4.500	4.500	4.500	4.500	4.500	3.100	3.100	3.100
	U	10.000	10.000	10.000	10.000	10.000	9.312	8.536	3.200	3.200	3.200
2250	S (L/100)	4.500	4.500	4.500	4.500	4.500	4.500	4.500	3.100	3.100	3.100
	U	10.000	10.000	10.000	10.000	10.000	10.000	9.263	3.200	3.200	3.200
2200	S (L/100)	4.500	4.500	4.500	4.500	4.500	4.500	4.500	3.100	3.100	3.100
	U	10.000	10.000	10.000	10.000	10.000	10.000	10.000	3.200	3.200	3.200
2150	S (L/100)	4.500	4.500	4.500	4.500	4.500	4.500	4.500	3.100	3.100	3.100
	U	10.000	10.000	10.000	10.000	10.000	10.000	10.000	3.200	3.200	3.200
2100	S (L/100)	4.500	4.500	4.500	4.500	4.500	4.500	4.500	3.100	3.100	3.100
	U	10.000	10.000	10.000	10.000	10.000	10.000	10.000	3.200	3.200	3.200
Sash Width (mm)		600	700	800	900	1000	1100	1200	1300	1400	1500

LEGEND: S = Serviceability Pressure, U = Ultimate Pressure

NOTE: This table is based on a combination of approved AS2047 testing data and theoretical section properties.

A maximum stress level of 110MPa has been applied when generating this table.

Span Table

WIDE LOCK STILE - SINGLE LOCKING POINT - EP14988 (EP14987 SIMILAR)



Note:

Serviceability pressures have been limited to a maximum pressure of 2200Pa.

Serviceability pressures have not been limited by water performance. Where water performance is necessary, refer to Product Specification page.

This table has been based on a lock height of 1050mm.

Sash Height (mm)		Maximum Design Pressure (kPa)						
3000	S (L/100)	0.756	0.648	0.567	0.504	0.454	0.413	-
	U	2.535	2.173	1.901	1.690	1.521	1.383	-
2950	S (L/100)	0.818	0.701	0.613	0.545	0.491	0.446	0.409
	U	2.670	2.289	2.003	1.780	1.602	1.456	1.335
2900	S (L/100)	0.886	0.759	0.664	0.591	0.531	0.483	0.443
	U	2.816	2.414	2.112	1.878	1.690	1.536	1.408
2850	S (L/100)	0.962	0.824	0.721	0.641	0.577	0.525	0.481
	U	2.975	2.550	2.231	1.983	1.785	1.623	1.487
2800	S (L/100)	1.046	0.897	0.785	0.698	0.628	0.571	0.523
	U	3.147	2.698	2.361	2.098	1.888	1.717	1.574
2750	S (L/100)	1.142	0.978	0.856	0.761	0.685	0.623	0.571
	U	3.300	2.859	2.501	2.223	2.001	1.819	1.668
2700	S (L/100)	1.249	1.070	0.936	0.832	0.749	0.681	0.624
	U	3.300	3.035	2.655	2.360	2.124	1.931	1.770
2650	S (L/100)	1.369	1.174	1.027	0.913	0.822	0.747	0.685
	U	3.300	3.227	2.824	2.510	2.259	2.054	1.883
2600	S (L/100)	1.506	1.291	1.130	1.004	0.904	0.822	0.753
	U	3.300	3.300	3.009	2.675	2.407	2.188	2.006
2550	S (L/100)	1.662	1.424	1.246	1.108	0.997	0.906	0.831
	U	3.300	3.300	3.213	2.856	2.570	2.337	2.142
2500	S (L/100)	1.840	1.577	1.380	1.226	1.104	1.003	0.920
	U	3.300	3.300	3.300	3.056	2.751	2.501	2.292
2450	S (L/100)	2.044	1.752	1.533	1.363	1.226	1.115	1.022
	U	3.300	3.300	3.300	3.278	2.951	2.682	2.459
2400	S (L/100)	2.200	1.954	1.710	1.520	1.368	1.243	1.140
	U	3.300	3.300	3.300	3.300	3.173	2.885	2.644
2350	S (L/100)	2.200	2.188	1.915	1.702	1.532	1.392	1.276
	U	3.300	3.300	3.300	3.300	3.300	3.111	2.852
2300	S (L/100)	2.200	2.200	2.154	1.914	1.723	1.566	1.436
	U	3.300	3.300	3.300	3.300	3.300	3.300	3.084
2250	S (L/100)	2.200	2.200	2.200	2.164	1.947	1.770	1.623
	U	3.300	3.300	3.300	3.300	3.300	3.300	3.300
2200	S (L/100)	2.200	2.200	2.200	2.200	2.200	2.011	1.844
	U	3.300	3.300	3.300	3.300	3.300	3.300	3.300
2150	S (L/100)	2.200	2.200	2.200	2.200	2.200	2.200	2.107
	U	3.300	3.300	3.300	3.300	3.300	3.300	3.300
2100	S (L/100)	2.200	2.200	2.200	2.200	2.200	2.200	2.200
	U	3.300	3.300	3.300	3.300	3.300	3.300	3.300
Sash Width (mm)		600	700	800	900	1000	1100	1200

LEGEND: S = Serviceability Pressure, U = Ultimate Pressure

NOTE: This table is based on theoretical section properties, not on approved tests as specified by AS2047. A maximum stress level of 110MPa has been applied when generating this table.

Span Table

WIDE LOCK STILE - TRIPLE LOCKING POINTS - EP14988 (EP14987 SIMILAR)



Note:

Serviceability pressures have been limited to a maximum pressure of 2200Pa.

Serviceability pressures have not been limited by water performance. Where water performance is necessary, refer to Product Specification page.

This table has been based on a lock height of 1050mm.

Sash Height (mm)		Maximum Design Pressure (kPa)						
3000	S (L/100)	2.200	2.200	2.200	2.200	2.200	2.200	2.200
	U	3.300	3.300	3.300	3.300	3.300	3.300	3.300
2950	S (L/100)	2.200	2.200	2.200	2.200	2.200	2.200	2.200
	U	3.300	3.300	3.300	3.300	3.300	3.300	3.300
2900	S (L/100)	2.200	2.200	2.200	2.200	2.200	2.200	2.200
	U	3.300	3.300	3.300	3.300	3.300	3.300	3.300
2850	S (L/100)	2.200	2.200	2.200	2.200	2.200	2.200	2.200
	U	3.300	3.300	3.300	3.300	3.300	3.300	3.300
2800	S (L/100)	2.200	2.200	2.200	2.200	2.200	2.200	2.200
	U	3.300	3.300	3.300	3.300	3.300	3.300	3.300
2750	S (L/100)	2.200	2.200	2.200	2.200	2.200	2.200	2.200
	U	3.300	3.300	3.300	3.300	3.300	3.300	3.300
2700	S (L/100)	2.200	2.200	2.200	2.200	2.200	2.200	2.200
	U	3.300	3.300	3.300	3.300	3.300	3.300	3.300
2650	S (L/100)	2.200	2.200	2.200	2.200	2.200	2.200	2.200
	U	3.300	3.300	3.300	3.300	3.300	3.300	3.300
2600	S (L/100)	2.200	2.200	2.200	2.200	2.200	2.200	2.200
	U	3.300	3.300	3.300	3.300	3.300	3.300	3.300
2550	S (L/100)	2.200	2.200	2.200	2.200	2.200	2.200	2.200
	U	3.300	3.300	3.300	3.300	3.300	3.300	3.300
2500	S (L/100)	2.200	2.200	2.200	2.200	2.200	2.200	2.200
	U	3.300	3.300	3.300	3.300	3.300	3.300	3.300
2450	S (L/100)	2.200	2.200	2.200	2.200	2.200	2.200	2.200
	U	3.300	3.300	3.300	3.300	3.300	3.300	3.300
2400	S (L/100)	2.200	2.200	2.200	2.200	2.200	2.200	2.200
	U	3.300	3.300	3.300	3.300	3.300	3.300	3.300
2350	S (L/100)	2.200	2.200	2.200	2.200	2.200	2.200	2.200
	U	3.300	3.300	3.300	3.300	3.300	3.300	3.300
2300	S (L/100)	2.200	2.200	2.200	2.200	2.200	2.200	2.200
	U	3.300	3.300	3.300	3.300	3.300	3.300	3.300
2250	S (L/100)	2.200	2.200	2.200	2.200	2.200	2.200	2.200
	U	3.300	3.300	3.300	3.300	3.300	3.300	3.300
2200	S (L/100)	2.200	2.200	2.200	2.200	2.200	2.200	2.200
	U	3.300	3.300	3.300	3.300	3.300	3.300	3.300
2150	S (L/100)	2.200	2.200	2.200	2.200	2.200	2.200	2.200
	U	3.300	3.300	3.300	3.300	3.300	3.300	3.300
2100	S (L/100)	2.200	2.200	2.200	2.200	2.200	2.200	2.200
	U	3.300	3.300	3.300	3.300	3.300	3.300	3.300
Sash Width (mm)		600	700	800	900	1000	1100	1200

LEGEND: S = Serviceability Pressure, U = Ultimate Pressure

NOTE: This table is based on theoretical section properties, not on approved tests as specified by AS2047.

A maximum stress level of 110MPa has been applied when generating this table.

Span Table

MEETING STILES - SINGLE LOCKING POINT - EP14649 / EP14649 (EP14895 / EP14895 Similar)

Note:

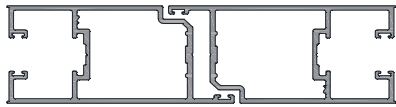

Serviceability pressures have been limited to a maximum pressure of 1500Pa.
 Servicability pressures have not been limited by water performance. Where water performance is necessary, refer to Product Specification page.

This table has been based on a lock height of 1050mm.

Sash Height (mm)		Maximum Design Pressure (kPa)						
3000	S (L/100)	0.583	0.500	0.438	-	-	-	-
	U	0.988	0.847	0.741	-	-	-	-
2950	S (L/100)	0.609	0.522	0.457	0.406	-	-	-
	U	1.017	0.871	0.762	0.678	-	-	-
2900	S (L/100)	0.637	0.546	0.478	0.425	-	-	-
	U	1.047	0.897	0.785	0.698	-	-	-
2850	S (L/100)	0.667	0.571	0.500	0.444	0.400	-	-
	U	1.079	0.925	0.809	0.719	0.647	-	-
2800	S (L/100)	0.698	0.599	0.524	0.466	0.419	-	-
	U	1.112	0.953	0.834	0.742	0.667	-	-
2750	S (L/100)	0.732	0.628	0.549	0.488	0.439	-	-
	U	1.148	0.984	0.861	0.765	0.689	-	-
2700	S (L/100)	0.769	0.659	0.577	0.513	0.461	0.419	-
	U	1.185	1.016	0.889	0.790	0.711	0.647	-
2650	S (L/100)	0.809	0.693	0.606	0.539	0.485	0.441	0.404
	U	1.225	1.050	0.919	0.817	0.735	0.668	0.613
2600	S (L/100)	0.851	0.730	0.638	0.567	0.511	0.464	0.426
	U	1.267	1.086	0.951	0.845	0.760	0.691	0.634
2550	S (L/100)	0.897	0.769	0.673	0.598	0.538	0.489	0.449
	U	1.312	1.125	0.984	0.875	0.787	0.716	0.656
2500	S (L/100)	0.947	0.812	0.710	0.632	0.568	0.517	0.474
	U	1.360	1.166	1.020	0.907	0.816	0.742	0.680
2450	S (L/100)	1.002	0.859	0.751	0.668	0.601	0.546	0.501
	U	1.411	1.210	1.059	0.941	0.847	0.770	0.706
2400	S (L/100)	1.061	0.909	0.796	0.707	0.637	0.579	0.530
	U	1.466	1.257	1.100	0.977	0.880	0.800	0.733
2350	S (L/100)	1.126	0.965	0.844	0.750	0.675	0.614	0.563
	U	1.525	1.307	1.144	1.017	0.915	0.832	0.762
2300	S (L/100)	1.197	1.026	0.898	0.798	0.718	0.653	0.598
	U	1.588	1.361	1.191	1.059	0.953	0.866	0.794
2250	S (L/100)	1.275	1.093	0.956	0.850	0.765	0.695	0.637
	U	1.656	1.419	1.242	1.104	0.993	0.903	0.828
2200	S (L/100)	1.361	1.166	1.021	0.907	0.816	0.742	0.680
	U	1.729	1.482	1.297	1.153	1.037	0.943	0.865
2150	S (L/100)	1.456	1.248	1.092	0.971	0.874	0.794	0.728
	U	1.809	1.550	1.356	1.206	1.085	0.986	0.904
2100	S (L/100)	1.500	1.339	1.171	1.041	0.937	0.852	0.781
	U	1.895	1.624	1.421	1.263	1.137	1.034	0.948
Sash Width (mm)		600	700	800	900	1000	1100	1200

LEGEND: S = Serviceability Pressure, U = Ultimate Pressure

NOTE: This table is based on a combination of approved AS2047 testing data and theoretical section properties.
 A maximum stress level of 110MPa has been applied when generating this table.

Span Table

MEETING STILES - TRIPLE LOCKING POINTS - EP14649 / EP14649 (EP14895 / EP14895 Similar)

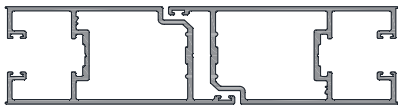

Note:

Serviceability pressures have been limited to a maximum pressure of 4000Pa.

Serviceability pressures have not been limited by water performance. Where water performance is necessary, refer to Product Specification page.

This table has been based on a lock height of 1050mm.

Sash Height (mm)		Maximum Design Pressure (kPa)						
3000	S (L/100)	1.393	1.194	1.045	0.928	0.836	0.760	0.696
	U	2.783	2.386	2.088	1.856	1.670	1.518	1.392
2950	S (L/100)	1.465	1.256	1.099	0.977	0.879	0.799	0.732
	U	2.879	2.467	2.159	1.919	1.727	1.570	1.439
2900	S (L/100)	1.542	1.322	1.156	1.028	0.925	0.841	0.771
	U	2.979	2.553	2.234	1.986	1.787	1.625	1.489
2850	S (L/100)	1.624	1.392	1.218	1.083	0.975	0.886	0.812
	U	3.084	2.644	2.313	2.056	1.850	1.682	1.542
2800	S (L/100)	1.713	1.468	1.285	1.142	1.028	0.934	0.857
	U	3.195	2.739	2.396	2.130	1.917	1.743	1.598
2750	S (L/100)	1.808	1.550	1.356	1.205	1.085	0.986	0.904
	U	3.312	2.839	2.484	2.208	1.987	1.807	1.656
2700	S (L/100)	1.910	1.638	1.433	1.274	1.146	1.042	0.955
	U	3.436	2.945	2.577	2.291	2.062	1.874	1.718
2650	S (L/100)	2.021	1.732	1.516	1.347	1.212	1.102	1.010
	U	3.567	3.058	2.675	2.378	2.140	1.946	1.784
2600	S (L/100)	2.140	1.834	1.605	1.426	1.284	1.167	1.070
	U	3.706	3.176	2.779	2.470	2.223	2.021	1.853
2550	S (L/100)	2.268	1.944	1.701	1.512	1.361	1.237	1.134
	U	3.852	3.302	2.889	2.568	2.311	2.101	1.926
2500	S (L/100)	2.407	2.063	1.805	1.604	1.444	1.313	1.203
	U	4.008	3.436	3.006	2.672	2.405	2.186	2.004
2450	S (L/100)	2.557	2.192	1.918	1.705	1.534	1.395	1.279
	U	4.173	3.577	3.130	2.782	2.504	2.276	2.087
2400	S (L/100)	2.720	2.332	2.040	1.813	1.632	1.484	1.360
	U	4.349	3.728	3.262	2.899	2.609	2.372	2.175
2350	S (L/100)	2.898	2.484	2.173	1.932	1.739	1.580	1.449
	U	4.536	3.888	3.402	3.024	2.722	2.474	2.268
2300	S (L/100)	3.091	2.649	2.318	2.060	1.854	1.686	1.545
	U	4.735	4.059	3.552	3.157	2.841	2.583	2.368
2250	S (L/100)	3.301	2.830	2.476	2.201	1.981	1.801	1.651
	U	4.948	4.241	3.711	3.299	2.969	2.699	2.474
2200	S (L/100)	3.532	3.027	2.649	2.354	2.119	1.926	1.766
	U	5.176	4.436	3.882	3.451	3.105	2.823	2.588
2150	S (L/100)	3.784	3.243	2.838	2.522	2.270	2.064	1.892
	U	5.419	4.645	4.064	3.613	3.252	2.956	2.710
2100	S (L/100)	4.000	3.480	3.045	2.707	2.436	2.215	2.030
	U	5.680	4.869	4.260	3.787	3.408	3.098	2.840
Sash Width (mm)		600	700	800	900	1000	1100	1200

LEGEND: S = Serviceability Pressure, U = Ultimate Pressure

NOTE: This table is based on a combination of approved AS2047 testing data and theoretical section properties.
A maximum stress level of 110MPa has been applied when generating this table.

Span Table

**COVER STILES - SINGLE LOCKING POINT - EP17134 / EP14647 (EP17135 / EP14893 Similar)
- EP18500 / EP14647 (EP18501 / EP14893 Similar)**

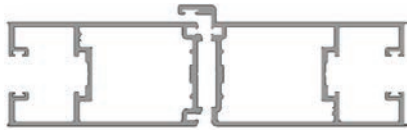

Note:

Serviceability pressures have been limited to a maximum pressure of 1500Pa.

Serviceability pressures have not been limited by water performance. Where water performance is necessary, refer to Product Specification page.

This table has been based on a lock height of 1050mm.

Sash Height (mm)		Maximum Design Pressure (kPa)						
3000	S (L/100)	0.687	0.589	0.515	0.458	0.412	-	-
	U	1.026	0.879	0.769	0.684	0.615	-	-
2950	S (L/100)	0.718	0.615	0.538	0.478	0.431	-	-
	U	1.055	0.905	0.792	0.704	0.633	-	-
2900	S (L/100)	0.750	0.643	0.563	0.500	0.450	0.409	-
	U	1.087	0.932	0.815	0.725	0.652	0.593	-
2850	S (L/100)	0.785	0.673	0.589	0.523	0.471	0.428	-
	U	1.120	0.960	0.840	0.747	0.672	0.611	-
2800	S (L/100)	0.823	0.705	0.617	0.548	0.494	0.449	0.411
	U	1.155	0.990	0.866	0.770	0.693	0.630	0.577
2750	S (L/100)	0.863	0.739	0.647	0.575	0.518	0.471	0.431
	U	1.192	1.021	0.894	0.794	0.715	0.650	0.596
2700	S (L/100)	0.906	0.776	0.679	0.604	0.544	0.494	0.453
	U	1.231	1.055	0.923	0.820	0.738	0.671	0.615
2650	S (L/100)	0.952	0.816	0.714	0.635	0.571	0.520	0.476
	U	1.272	1.090	0.954	0.848	0.763	0.694	0.636
2600	S (L/100)	1.003	0.859	0.752	0.668	0.602	0.547	0.501
	U	1.316	1.128	0.987	0.877	0.790	0.718	0.658
2550	S (L/100)	1.057	0.906	0.793	0.705	0.634	0.577	0.529
	U	1.363	1.168	1.022	0.908	0.818	0.743	0.681
2500	S (L/100)	1.116	0.957	0.837	0.744	0.670	0.609	0.558
	U	1.412	1.211	1.059	0.942	0.847	0.770	0.706
2450	S (L/100)	1.180	1.011	0.885	0.787	0.708	0.644	0.590
	U	1.465	1.256	1.099	0.977	0.879	0.799	0.733
2400	S (L/100)	1.250	1.071	0.937	0.833	0.750	0.682	0.625
	U	1.522	1.305	1.142	1.015	0.913	0.830	0.761
2350	S (L/100)	1.326	1.137	0.995	0.884	0.796	0.723	0.663
	U	1.583	1.357	1.187	1.055	0.950	0.863	0.791
2300	S (L/100)	1.410	1.208	1.057	0.940	0.846	0.769	0.705
	U	1.648	1.413	1.236	1.099	0.989	0.899	0.824
2250	S (L/100)	1.500	1.287	1.126	1.001	0.901	0.819	0.751
	U	1.719	1.473	1.289	1.146	1.031	0.938	0.859
2200	S (L/100)	1.500	1.374	1.202	1.069	0.962	0.874	0.801
	U	1.795	1.539	1.346	1.197	1.077	0.979	0.898
2150	S (L/100)	1.500	1.470	1.286	1.143	1.029	0.936	0.858
	U	1.878	1.609	1.408	1.252	1.127	1.024	0.939
2100	S (L/100)	1.500	1.577	1.380	1.226	1.104	1.003	0.920
	U	1.967	1.686	1.476	1.312	1.180	1.073	0.984
Sash Width (mm)		600	700	800	900	1000	1100	1200

LEGEND: S = Serviceability Pressure, U = Ultimate Pressure

NOTE: This table is based on theoretical section properties, not on approved tests as specified by AS2047.

A maximum stress level of 110MPa has been applied when generating this table.

Please read in conjunction with Important Conditions – Index (also available on Capral website)

Span Table

COVER STILES - TRIPLE LOCKING POINT - EP17134 / EP14647 (EP17135 / EP14893 Similar)

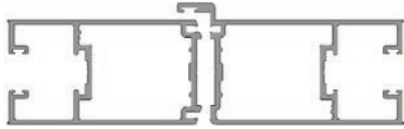

Note:

Serviceability pressures have been limited to a maximum pressure of 4000Pa.

Serviceability pressures have not been limited by water performance. Where water performance is necessary, refer to Product Specification page.

This table has been based on a lock height of 1050mm.

Sash Height (mm)		Maximum Design Pressure (kPa)						
3000	S (L/100)	1.510	1.295	1.133	1.007	0.906	0.824	0.755
	U	2.666	2.285	2.000	1.778	1.600	1.454	1.333
2950	S (L/100)	1.589	1.362	1.191	1.059	0.953	0.867	0.794
	U	2.758	2.364	2.068	1.838	1.655	1.504	1.379
2900	S (L/100)	1.672	1.433	1.254	1.115	1.003	0.912	0.836
	U	2.853	2.446	2.140	1.902	1.712	1.556	1.427
2850	S (L/100)	1.762	1.510	1.321	1.175	1.057	0.961	0.881
	U	2.954	2.532	2.216	1.970	1.773	1.612	1.477
2800	S (L/100)	1.858	1.592	1.393	1.239	1.115	1.013	0.929
	U	3.061	2.624	2.296	2.041	1.837	1.670	1.530
2750	S (L/100)	1.961	1.681	1.471	1.307	1.177	1.070	0.981
	U	3.173	2.720	2.380	2.115	1.904	1.731	1.587
2700	S (L/100)	2.072	1.776	1.554	1.381	1.243	1.130	1.036
	U	3.292	2.822	2.469	2.195	1.975	1.796	1.646
2650	S (L/100)	2.192	1.878	1.644	1.461	1.315	1.195	1.096
	U	3.417	2.929	2.563	2.278	2.050	1.864	1.709
2600	S (L/100)	2.320	1.989	1.740	1.547	1.392	1.266	1.160
	U	3.550	3.043	2.662	2.367	2.130	1.936	1.775
2550	S (L/100)	2.460	2.108	1.845	1.640	1.476	1.342	1.230
	U	3.690	3.163	2.768	2.460	2.214	2.013	1.845
2500	S (L/100)	2.610	2.237	1.958	1.740	1.566	1.424	1.305
	U	3.840	3.291	2.880	2.560	2.304	2.094	1.920
2450	S (L/100)	2.773	2.377	2.080	1.849	1.664	1.513	1.387
	U	3.998	3.427	2.998	2.665	2.399	2.181	1.999
2400	S (L/100)	2.950	2.529	2.213	1.967	1.770	1.609	1.475
	U	4.166	3.571	3.125	2.777	2.500	2.272	2.083
2350	S (L/100)	3.143	2.694	2.357	2.095	1.886	1.714	1.571
	U	4.345	3.725	3.259	2.897	2.607	2.370	2.173
2300	S (L/100)	3.352	2.873	2.514	2.235	2.011	1.828	1.676
	U	4.536	3.888	3.402	3.024	2.722	2.474	2.268
2250	S (L/100)	3.580	3.069	2.685	2.387	2.148	1.953	1.790
	U	4.740	4.063	3.555	3.160	2.844	2.586	2.370
2200	S (L/100)	3.830	3.283	2.873	2.553	2.298	2.089	1.915
	U	4.958	4.250	3.719	3.305	2.975	2.704	2.479
2150	S (L/100)	4.000	3.517	3.078	2.736	2.462	2.238	2.052
	U	5.191	4.450	3.894	3.461	3.115	2.832	2.596
2100	S (L/100)	4.000	3.775	3.303	2.936	2.642	2.402	2.202
	U	5.442	4.664	4.081	3.628	3.265	2.968	2.721
Sash Width (mm)		600	700	800	900	1000	1100	1200

LEGEND: S = Serviceability Pressure, U = Ultimate Pressure

NOTE: This table is based on theoretical section properties, not on approved tests as specified by AS2047.
A maximum stress level of 110MPa has been applied when generating this table.

Span Table

STD & WIDE COVER STILES - TRIPLE LOCKING POINT - EP14647 / EP18500 (EP14893 / EP18501 Similar)

Note:



Serviceability pressures have been limited to a maximum pressure of 2200Pa.

Serviceability pressures have not been limited by water performance. Where water performance is necessary, refer to Product Specification page.

This table has been based on a lock height of 1050mm.

Sash Height (mm)		Maximum Design Pressure (kPa)						
3000	S (L/100)	1.903	1.632	1.428	1.269	1.142	1.038	0.952
	U	3.278	2.810	2.459	2.186	1.967	1.788	1.639
2950	S (L/100)	2.002	1.716	1.501	1.335	1.201	1.092	1.001
	U	3.300	2.906	2.543	2.260	2.034	1.849	1.695
2900	S (L/100)	2.107	1.806	1.580	1.405	1.264	1.149	1.054
	U	3.300	3.007	2.631	2.339	2.105	1.914	1.754
2850	S (L/100)	2.200	1.903	1.665	1.480	1.332	1.211	1.110
	U	3.300	3.114	2.724	2.422	2.180	1.981	1.816
2800	S (L/100)	2.200	2.007	1.756	1.561	1.405	1.277	1.171
	U	3.300	3.226	2.823	2.509	2.258	2.053	1.882
2750	S (L/100)	2.200	2.118	1.853	1.648	1.483	1.348	1.236
	U	3.300	3.300	2.926	2.601	2.341	2.128	1.951
2700	S (L/100)	2.200	2.200	1.958	1.741	1.567	1.424	1.306
	U	3.300	3.300	3.036	2.698	2.428	2.208	2.024
2650	S (L/100)	2.200	2.200	2.071	1.841	1.657	1.506	1.381
	U	3.300	3.300	3.151	2.801	2.521	2.292	2.101
2600	S (L/100)	2.200	2.200	2.193	1.949	1.754	1.595	1.462
	U	3.300	3.300	3.274	2.910	2.619	2.381	2.182
2550	S (L/100)	2.200	2.200	2.200	2.066	1.860	1.691	1.550
	U	3.300	3.300	3.300	3.025	2.723	2.475	2.269
2500	S (L/100)	2.200	2.200	2.200	2.193	1.974	1.794	1.645
	U	3.300	3.300	3.300	3.147	2.833	2.575	2.360
2450	S (L/100)	2.200	2.200	2.200	2.200	2.097	1.906	1.747
	U	3.300	3.300	3.300	3.277	2.949	2.681	2.458
2400	S (L/100)	2.200	2.200	2.200	2.200	2.200	2.028	1.859
	U	3.300	3.300	3.300	3.300	3.074	2.794	2.561
2350	S (L/100)	2.200	2.200	2.200	2.200	2.200	2.160	1.980
	U	3.300	3.300	3.300	3.300	3.206	2.914	2.671
2300	S (L/100)	2.200	2.200	2.200	2.200	2.200	2.200	2.112
	U	3.300	3.300	3.300	3.300	3.300	3.042	2.789
2250	S (L/100)	2.200	2.200	2.200	2.200	2.200	2.200	2.200
	U	3.300	3.300	3.300	3.300	3.300	3.179	2.914
2200	S (L/100)	2.200	2.200	2.200	2.200	2.200	2.200	2.200
	U	3.300	3.300	3.300	3.300	3.300	3.300	3.048
2150	S (L/100)	2.200	2.200	2.200	2.200	2.200	2.200	2.200
	U	3.300	3.300	3.300	3.300	3.300	3.300	3.192
2100	S (L/100)	2.200	2.200	2.200	2.200	2.200	2.200	2.200
	U	3.300	3.300	3.300	3.300	3.300	3.300	3.300
Sash Width (mm)		600	700	800	900	1000	1100	1200

LEGEND: S = Serviceability Pressure, U = Ultimate Pressure

NOTE: This table is based on theoretical section properties, not on approved tests as specified by AS2047.
A maximum stress level of 110MPa has been applied when generating this table.

Span Table

WIDE COVER STILES - SINGLE LOCKING POINT - EP14988 / EP18500 (EP14987 / EP18501 Similar)

Note:

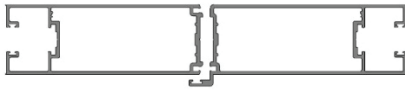

Serviceability pressures have been limited to a maximum pressure of 1500Pa.

Serviceability pressures have not been limited by water performance. Where water performance is necessary, refer to Product Specification page.

This table has been based on a lock height of 1050mm.

Sash Height (mm)		Maximum Design Pressure (kPa)						
3000	S (L/100)	0.835	0.716	0.626	0.557	0.501	0.456	0.418
	U	1.518	1.302	1.139	1.012	0.911	0.828	0.759
2950	S (L/100)	0.872	0.748	0.654	0.582	0.523	0.476	0.436
	U	1.563	1.339	1.172	1.042	0.938	0.852	0.781
2900	S (L/100)	0.912	0.782	0.684	0.608	0.547	0.497	0.456
	U	1.609	1.379	1.207	1.073	0.965	0.878	0.805
2850	S (L/100)	0.954	0.818	0.716	0.636	0.573	0.521	0.477
	U	1.658	1.421	1.244	1.105	0.995	0.904	0.829
2800	S (L/100)	1.000	0.857	0.750	0.667	0.600	0.545	0.500
	U	1.710	1.466	1.282	1.140	1.026	0.933	0.855
2750	S (L/100)	1.049	0.899	0.786	0.699	0.629	0.572	0.524
	U	1.764	1.512	1.323	1.176	1.059	0.962	0.882
2700	S (L/100)	1.101	0.944	0.826	0.734	0.661	0.601	0.551
	U	1.822	1.562	1.367	1.215	1.093	0.994	0.911
2650	S (L/100)	1.158	0.992	0.868	0.772	0.695	0.631	0.579
	U	1.883	1.614	1.413	1.256	1.130	1.027	0.942
2600	S (L/100)	1.219	1.045	0.914	0.812	0.731	0.665	0.609
	U	1.948	1.670	1.461	1.299	1.169	1.063	0.974
2550	S (L/100)	1.285	1.101	0.964	0.856	0.771	0.701	0.642
	U	2.017	1.729	1.513	1.345	1.210	1.100	1.009
2500	S (L/100)	1.356	1.163	1.017	0.904	0.814	0.740	0.678
	U	2.091	1.792	1.568	1.394	1.255	1.141	1.046
2450	S (L/100)	1.434	1.229	1.076	0.956	0.861	0.782	0.717
	U	2.170	1.860	1.627	1.446	1.302	1.183	1.085
2400	S (L/100)	1.500	1.302	1.139	1.013	0.911	0.829	0.760
	U	2.254	1.932	1.690	1.502	1.352	1.229	1.127
2350	S (L/100)	1.500	1.382	1.209	1.075	0.967	0.879	0.806
	U	2.344	2.009	1.758	1.563	1.406	1.278	1.172
2300	S (L/100)	1.500	1.469	1.285	1.142	1.028	0.935	0.857
	U	2.441	2.092	1.831	1.627	1.464	1.331	1.220
2250	S (L/100)	1.500	1.500	1.369	1.217	1.095	0.996	0.913
	U	2.545	2.181	1.909	1.697	1.527	1.388	1.273
2200	S (L/100)	1.500	1.500	1.461	1.299	1.169	1.063	0.974
	U	2.658	2.278	1.993	1.772	1.595	1.450	1.329
2150	S (L/100)	1.500	1.500	1.500	1.390	1.251	1.137	1.042
	U	2.780	2.383	2.085	1.853	1.668	1.516	1.390
2100	S (L/100)	1.500	1.917	1.677	1.491	1.342	1.220	1.118
	U	2.913	2.497	2.185	1.942	1.748	1.589	1.456
Sash Width (mm)		600	700	800	900	1000	1100	1200

LEGEND: S = Serviceability Pressure, U = Ultimate Pressure

NOTE: This table is based on theoretical section properties, not on approved tests as specified by AS2047.
A maximum stress level of 110MPa has been applied when generating this table.

Span Table

WIDE COVER STILES - TRIPLE LOCKING POINT - EP14988 / EP18500 (EP14987 / EP18501 Similar)

Note:

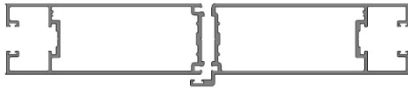

Serviceability pressures have been limited to a maximum pressure of 2200Pa.
 Serviceability pressures have not been limited by water performance. Where water performance is necessary, refer to Product Specification page.

This table has been based on a lock height of 1050mm.

Sash Height (mm)		Maximum Design Pressure (kPa)						
3000	S (L/100)	2.200	1.895	1.658	1.474	1.326	1.206	1.105
	U	3.300	3.263	2.855	2.538	2.284	2.077	1.904
2950	S (L/100)	2.200	1.993	1.744	1.550	1.395	1.268	1.162
	U	3.300	3.300	2.953	2.625	2.362	2.148	1.969
2900	S (L/100)	2.200	2.097	1.835	1.631	1.468	1.335	1.224
	U	3.300	3.300	3.056	2.716	2.444	2.222	2.037
2850	S (L/100)	2.200	2.200	1.934	1.719	1.547	1.406	1.289
	U	3.300	3.300	3.164	2.812	2.531	2.301	2.109
2800	S (L/100)	2.200	2.200	2.039	1.812	1.631	1.483	1.359
	U	3.300	3.300	3.278	2.914	2.622	2.384	2.185
2750	S (L/100)	2.200	2.200	2.152	1.913	1.722	1.565	1.435
	U	3.300	3.300	3.300	3.020	2.718	2.471	2.265
2700	S (L/100)	2.200	2.200	2.200	2.021	1.819	1.654	1.516
	U	3.300	3.300	3.300	3.133	2.820	2.564	2.350
2650	S (L/100)	2.200	2.200	2.200	2.138	1.924	1.749	1.603
	U	3.300	3.300	3.300	3.253	2.927	2.661	2.440
2600	S (L/100)	2.200	2.200	2.200	2.200	2.037	1.852	1.698
	U	3.300	3.300	3.300	3.300	3.041	2.765	2.534
2550	S (L/100)	2.200	2.200	2.200	2.200	2.160	1.963	1.800
	U	3.300	3.300	3.300	3.300	3.162	2.874	2.635
2500	S (L/100)	2.200	2.200	2.200	2.200	2.200	2.083	1.910
	U	3.300	3.300	3.300	3.300	3.289	2.990	2.741
2450	S (L/100)	2.200	2.200	2.200	2.200	2.200	2.200	2.029
	U	3.300	3.300	3.300	3.300	3.300	3.114	2.854
2400	S (L/100)	2.200	2.200	2.200	2.200	2.200	2.200	2.159
	U	3.300	3.300	3.300	3.300	3.300	3.245	2.974
2350	S (L/100)	2.200	2.200	2.200	2.200	2.200	2.200	2.200
	U	3.300	3.300	3.300	3.300	3.300	3.300	3.102
2300	S (L/100)	2.200	2.200	2.200	2.200	2.200	2.200	2.200
	U	3.300	3.300	3.300	3.300	3.300	3.300	3.238
2250	S (L/100)	2.200	2.200	2.200	2.200	2.200	2.200	2.200
	U	3.300	3.300	3.300	3.300	3.300	3.300	3.300
2200	S (L/100)	2.200	2.200	2.200	2.200	2.200	2.200	2.200
	U	3.300	3.300	3.300	3.300	3.300	3.300	3.300
2150	S (L/100)	2.200	2.200	2.200	2.200	2.200	2.200	2.200
	U	3.300	3.300	3.300	3.300	3.300	3.300	3.300
2100	S (L/100)	2.200	2.200	2.200	2.200	2.200	2.200	2.200
	U	3.300	3.300	3.300	3.300	3.300	3.300	3.300
Sash Width (mm)		600	700	800	900	1000	1100	1200

LEGEND: S = Serviceability Pressure, U = Ultimate Pressure

NOTE: This table is based on theoretical section properties, not on approved tests as specified by AS2047.
 A maximum stress level of 110MPa has been applied when generating this table.

Span Table

PIVOT MEETING STILES - SINGLE LOCKING POINT - EP14647 / EP14647 (EP14893 / EP14893 SIMILAR)

Note:

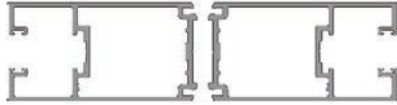

Serviceability pressures have been limited to a maximum pressure of 1500Pa.

Serviceability pressures have not been limited by water performance. Where water performance is necessary, refer to Product Specification page.

This table has been based on a lock height of 1050mm.

Sash Height (mm)		Maximum Design Pressure (kPa)						
3000	S (L/100)	0.578	0.496	0.434	-	-	-	-
	U	1.051	0.901	0.788	-	-	-	-
2950	S (L/100)	0.604	0.518	0.453	0.403	-	-	-
	U	1.082	0.927	0.811	0.721	-	-	-
2900	S (L/100)	0.631	0.541	0.473	0.421	-	-	-
	U	1.114	0.955	0.835	0.743	-	-	-
2850	S (L/100)	0.661	0.566	0.495	0.440	-	-	-
	U	1.148	0.984	0.861	0.765	-	-	-
2800	S (L/100)	0.692	0.593	0.519	0.461	0.415	-	-
	U	1.183	1.014	0.888	0.789	0.710	-	-
2750	S (L/100)	0.726	0.622	0.544	0.484	0.436	-	-
	U	1.221	1.047	0.916	0.814	0.733	-	-
2700	S (L/100)	0.762	0.653	0.572	0.508	0.457	0.416	-
	U	1.261	1.081	0.946	0.841	0.757	0.688	-
2650	S (L/100)	0.801	0.687	0.601	0.534	0.481	0.437	0.401
	U	1.304	1.117	0.978	0.869	0.782	0.711	0.652
2600	S (L/100)	0.844	0.723	0.633	0.562	0.506	0.460	0.422
	U	1.349	1.156	1.011	0.899	0.809	0.736	0.674
2550	S (L/100)	0.889	0.762	0.667	0.593	0.534	0.485	0.445
	U	1.396	1.197	1.047	0.931	0.838	0.762	0.698
2500	S (L/100)	0.939	0.805	0.704	0.626	0.563	0.512	0.469
	U	1.447	1.241	1.086	0.965	0.868	0.790	0.724
2450	S (L/100)	0.993	0.851	0.745	0.662	0.596	0.542	0.496
	U	1.502	1.287	1.126	1.001	0.901	0.819	0.751
2400	S (L/100)	1.052	0.901	0.789	0.701	0.631	0.574	0.526
	U	1.560	1.337	1.170	1.040	0.936	0.851	0.780
2350	S (L/100)	1.116	0.956	0.837	0.744	0.669	0.609	0.558
	U	1.622	1.391	1.217	1.082	0.973	0.885	0.811
2300	S (L/100)	1.186	1.017	0.890	0.791	0.712	0.647	0.593
	U	1.689	1.448	1.267	1.126	1.014	0.922	0.845
2250	S (L/100)	1.263	1.083	0.948	0.842	0.758	0.689	0.632
	U	1.762	1.510	1.321	1.174	1.057	0.961	0.881
2200	S (L/100)	1.349	1.156	1.011	0.899	0.809	0.736	0.674
	U	1.840	1.577	1.380	1.226	1.104	1.003	0.920
2150	S (L/100)	1.443	1.237	1.082	0.962	0.866	0.787	0.721
	U	1.924	1.649	1.443	1.283	1.155	1.050	0.962
2100	S (L/100)	1.500	1.327	1.161	1.032	0.929	0.844	0.774
	U	2.016	1.728	1.512	1.344	1.210	1.100	1.008
Sash Width (mm)		600	700	800	900	1000	1100	1200

LEGEND: S = Serviceability Pressure, U = Ultimate Pressure

NOTE: This table is based on theoretical section properties, not on approved tests as specified by AS2047.
A maximum stress level of 110MPa has been applied when generating this table.

Span Table

SLIDING WIPER STILE - EP14960 (EP14961, EP14647 & EP14893 SIMILAR)

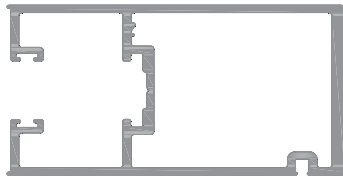

Note:

Serviceability pressures have been limited to a maximum pressure of 1500Pa.
 Servicability pressures have not been limited by water performance. Where water performance is necessary, refer to Product Specification page.

Sash Height (mm)		Maximum Design Pressure (kPa)						
2700	S (L/250)	0.541	0.471	0.420	-	-	-	-
	U	2.558	2.223	1.978	-	-	-	-
2650	S (L/250)	0.573	0.500	0.446	0.406	-	-	-
	U	2.659	2.313	2.059	1.866	-	-	-
2600	S (L/250)	0.608	0.530	0.474	0.431	-	-	-
	U	2.767	2.408	2.145	1.946	-	-	-
2550	S (L/250)	0.646	0.564	0.504	0.459	0.425	-	-
	U	2.881	2.509	2.236	2.031	1.873	-	-
2500	S (L/250)	0.687	0.600	0.537	0.490	0.454	0.426	0.405
	U	3.003	2.617	2.334	2.122	1.959	1.833	1.737
2450	S (L/250)	0.731	0.639	0.573	0.523	0.485	0.457	0.435
	U	3.133	2.732	2.439	2.219	2.051	1.922	1.824
2400	S (L/250)	0.780	0.682	0.612	0.559	0.520	0.490	0.467
	U	3.271	2.854	2.551	2.323	2.151	2.019	1.919
2350	S (L/250)	0.832	0.729	0.655	0.599	0.558	0.527	0.503
	U	3.300	2.986	2.671	2.436	2.258	2.122	2.021
2300	S (L/250)	0.890	0.781	0.702	0.643	0.600	0.567	0.543
	U	3.300	3.127	2.800	2.557	2.373	2.235	2.133
2250	S (L/250)	0.954	0.837	0.753	0.692	0.646	0.612	0.588
	U	3.300	3.278	2.939	2.687	2.498	2.357	2.255
2200	S (L/250)	1.023	0.899	0.811	0.745	0.697	0.662	0.637
	U	3.300	3.300	3.089	2.828	2.634	2.491	2.388
2150	S (L/250)	1.100	0.968	0.874	0.805	0.754	0.718	0.693
	U	3.300	3.300	3.251	2.982	2.782	2.637	2.535
2100	S (L/250)	1.185	1.044	0.944	0.871	0.818	0.780	0.755
	U	3.300	3.300	3.300	3.148	2.944	2.797	2.696
Sash Width (mm)		900	1050	1200	1350	1500	1650	1800

LEGEND: S = Serviceability Pressure, U = Ultimate Pressure

NOTE: This table is based on theoretical section properties, not on approved tests as specified by AS2047.
 A maximum stress level of 110MPa has been applied when generating this table.

Span Table

SLIDING WIDE WIPER STILE - EP14984 (EP14985, EP14987, EP14988 SIMILAR)

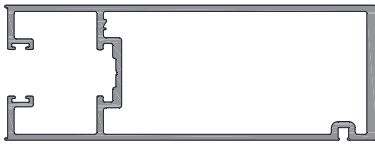

Note:

Serviceability pressures have been limited to a maximum pressure of 2200Pa.

Serviceability pressures have not been limited by water performance. Where water performance is necessary, refer to Product Specification page.

Sash Height (mm)		Maximum Design Pressure (kPa)						
2700	S (L/250)	0.776	0.676	0.603	0.548	0.506	0.473	0.447
	U	3.300	3.201	2.848	2.579	2.372	2.210	2.082
2650	S (L/250)	0.822	0.717	0.640	0.582	0.537	0.503	0.476
	U	3.300	3.300	2.964	2.687	2.473	2.306	2.175
2600	S (L/250)	0.872	0.761	0.680	0.619	0.572	0.536	0.508
	U	3.300	3.300	3.088	2.802	2.581	2.410	2.276
2550	S (L/250)	0.926	0.809	0.723	0.659	0.610	0.572	0.543
	U	3.300	3.300	3.220	2.924	2.697	2.521	2.384
2500	S (L/250)	0.985	0.861	0.770	0.702	0.651	0.612	0.581
	U	3.300	3.300	3.300	3.055	2.821	2.640	2.501
2450	S (L/250)	1.049	0.917	0.821	0.750	0.696	0.655	0.624
	U	3.300	3.300	3.300	3.195	2.953	2.768	2.626
2400	S (L/250)	1.118	0.979	0.878	0.802	0.746	0.703	0.670
	U	3.300	3.300	3.300	3.300	3.096	2.906	2.762
2350	S (L/250)	1.194	1.046	0.939	0.860	0.800	0.755	0.722
	U	3.300	3.300	3.300	3.300	3.251	3.056	2.910
2300	S (L/250)	1.277	1.120	1.007	0.923	0.860	0.813	0.779
	U	3.300	3.300	3.300	3.300	3.300	3.218	3.071
2250	S (L/250)	1.368	1.201	1.081	0.992	0.926	0.878	0.843
	U	3.300	3.300	3.300	3.300	3.300	3.300	3.246
2200	S (L/250)	1.468	1.290	1.163	1.069	1.000	0.949	0.914
	U	3.300	3.300	3.300	3.300	3.300	3.300	3.300
2150	S (L/250)	1.578	1.388	1.253	1.154	1.082	1.029	0.993
	U	3.300	3.300	3.300	3.300	3.300	3.300	3.300
2050	S (L/250)	1.699	1.497	1.353	1.249	1.173	1.119	1.083
	U	3.300	3.300	3.300	3.300	3.300	3.300	3.300
Sash Width (mm)		900	1050	1200	1350	1500	1650	1800

LEGEND: S = Serviceability Pressure, U = Ultimate Pressure

NOTE: This table is based on theoretical section properties, not on approved tests as specified by AS2047.
A maximum stress level of 110MPa has been applied when generating this table.

Span Table

SLIDING MEETING STILE - EP17134 / EP14647 (EP17134 & EP14648, EP17135 & EP14893, EP17135 & EP14894 SIMILAR)

Note:

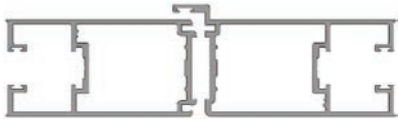

Serviceability pressures have been limited to a maximum pressure of 1500Pa.
 Serviceability pressures have not been limited by water performance. Where water performance is necessary, refer to Product Specification page.

Sash Height (mm)		Maximum Design Pressure (kPa)						
2700	S (L/250)	0.578	0.504	0.449	0.408	-	-	-
	U	2.279	1.981	1.762	1.596	-	-	-
2650	S (L/250)	0.612	0.534	0.477	0.433	0.400	-	-
	U	2.369	2.061	1.834	1.663	1.530	-	-
2600	S (L/250)	0.650	0.567	0.506	0.461	0.426	-	-
	U	2.465	2.145	1.911	1.734	1.597	-	-
2550	S (L/250)	0.690	0.602	0.539	0.491	0.454	0.426	0.405
	U	2.567	2.235	1.992	1.809	1.669	1.560	1.475
2500	S (L/250)	0.734	0.641	0.574	0.523	0.485	0.456	0.433
	U	2.675	2.331	2.079	1.890	1.745	1.633	1.547
2450	S (L/250)	0.781	0.683	0.612	0.559	0.519	0.488	0.465
	U	2.791	2.433	2.173	1.977	1.827	1.713	1.625
2400	S (L/250)	0.833	0.729	0.654	0.598	0.555	0.523	0.499
	U	2.914	2.543	2.272	2.070	1.916	1.798	1.709
2350	S (L/250)	0.889	0.779	0.700	0.640	0.596	0.563	0.538
	U	3.046	2.660	2.380	2.170	2.011	1.891	1.801
2300	S (L/250)	0.951	0.834	0.750	0.687	0.641	0.606	0.580
	U	3.187	2.786	2.495	2.278	2.114	1.991	1.900
2250	S (L/250)	1.019	0.895	0.805	0.739	0.690	0.654	0.628
	U	3.300	2.921	2.618	2.394	2.226	2.100	2.009
2200	S (L/250)	1.093	0.961	0.866	0.796	0.745	0.707	0.681
	U	3.300	3.066	2.752	2.520	2.347	2.219	2.127
2150	S (L/250)	1.175	1.034	0.933	0.860	0.806	0.767	0.740
	U	3.300	3.223	2.896	2.656	2.479	2.349	2.258
2050	S (L/250)	1.266	1.115	1.008	0.930	0.874	0.834	0.807
	U	3.300	3.300	3.053	2.805	2.623	2.491	2.402
Sash Width (mm)		900	1050	1200	1350	1500	1650	1800

LEGEND: S = Serviceability Pressure, U = Ultimate Pressure

NOTE: This table is based on theoretical section properties, not on approved tests as specified by AS2047.
 A maximum stress level of 110MPa has been applied when generating this table.

Span Table

HINGED & SLIDING 174mm COUPLED MIDRAIL - EP18289 / EP18289 (EP18286 / EP18286 SIMILAR)

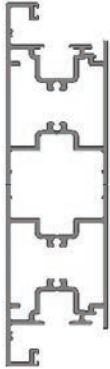

Note:

Serviceability pressures have been limited to a maximum pressure of 2200Pa.

Serviceability pressures have not been limited by water performance. Where water performance is necessary, refer to Product Specification page.

This table has been based on a below midrail height of 900mm.

Above Midrail Height (mm)		Maximum Design Pressure (kPa)						
2100	S (L/250)	2.200	2.200	2.200	2.200	2.200	1.842	1.337
	S (L/100)	2.200	2.200	2.200	2.200	2.200	2.200	2.200
	U	3.300	3.300	3.300	3.300	3.300	3.300	3.300
2000	S (L/250)	2.200	2.200	2.200	2.200	2.200	1.842	1.337
	S (L/100)	2.200	2.200	2.200	2.200	2.200	2.200	2.200
	U	3.300	3.300	3.300	3.300	3.300	3.300	3.300
1900	S (L/250)	2.200	2.200	2.200	2.200	2.200	1.842	1.337
	S (L/100)	2.200	2.200	2.200	2.200	2.200	2.200	2.200
	U	3.300	3.300	3.300	3.300	3.300	3.300	3.300
1800	S (L/250)	2.200	2.200	2.200	2.200	2.200	1.842	1.337
	S (L/100)	2.200	2.200	2.200	2.200	2.200	2.200	2.200
	U	3.300	3.300	3.300	3.300	3.300	3.300	3.300
1700	S (L/250)	2.200	2.200	2.200	2.200	2.200	1.842	1.340
	S (L/100)	2.200	2.200	2.200	2.200	2.200	2.200	2.200
	U	3.300	3.300	3.300	3.300	3.300	3.300	3.300
1600	S (L/250)	2.200	2.200	2.200	2.200	2.200	1.842	1.349
	S (L/100)	2.200	2.200	2.200	2.200	2.200	2.200	2.200
	U	3.300	3.300	3.300	3.300	3.300	3.300	3.300
1500	S (L/250)	2.200	2.200	2.200	2.200	2.200	1.851	1.364
	S (L/100)	2.200	2.200	2.200	2.200	2.200	2.200	2.200
	U	3.300	3.300	3.300	3.300	3.300	3.300	3.300
1400	S (L/250)	2.200	2.200	2.200	2.200	2.200	1.871	1.386
	S (L/100)	2.200	2.200	2.200	2.200	2.200	2.200	2.200
	U	3.300	3.300	3.300	3.300	3.300	3.300	3.300
1300	S (L/250)	2.200	2.200	2.200	2.200	2.200	1.901	1.415
	S (L/100)	2.200	2.200	2.200	2.200	2.200	2.200	2.200
	U	3.300	3.300	3.300	3.300	3.300	3.300	3.300
1200	S (L/250)	2.200	2.200	2.200	2.200	2.200	1.942	1.452
	S (L/100)	2.200	2.200	2.200	2.200	2.200	2.200	2.200
	U	3.300	3.300	3.300	3.300	3.300	3.300	3.300
Midrail Width (mm)		900	1050	1200	1350	1500	1650	1800

LEGEND: S = Serviceability Pressure, U = Ultimate Pressure

NOTE: This table is based on theoretical section properties, not on approved tests as specified by AS2047.

A maximum stress level of 110MPa has been applied when generating this table.

Span Table

HINGED & SLIDING 197mm COUPLED MIDRAIL - EP18288 / EP18289 (EP18287 / EP18286 SIMILAR)



Note:

Serviceability pressures have been limited to a maximum pressure of 2200Pa.

Serviceability pressures have not been limited by water performance. Where water performance is necessary, refer to Product Specification page.

This table has been based on a below midrail height of 900mm.

Above Midrail Height (mm)		Maximum Design Pressure (kPa)						
2100	S (L/250)	2.200	2.200	2.200	2.200	2.200	2.053	1.490
	S (L/100)	2.200	2.200	2.200	2.200	2.200	2.200	2.200
	U	3.300	3.300	3.300	3.300	3.300	3.300	3.300
2000	S (L/250)	2.200	2.200	2.200	2.200	2.200	2.053	1.490
	S (L/100)	2.200	2.200	2.200	2.200	2.200	2.200	2.200
	U	3.300	3.300	3.300	3.300	3.300	3.300	3.300
1900	S (L/250)	2.200	2.200	2.200	2.200	2.200	2.053	1.490
	S (L/100)	2.200	2.200	2.200	2.200	2.200	2.200	2.200
	U	3.300	3.300	3.300	3.300	3.300	3.300	3.300
1800	S (L/250)	2.200	2.200	2.200	2.200	2.200	2.053	1.490
	S (L/100)	2.200	2.200	2.200	2.200	2.200	2.200	2.200
	U	3.300	3.300	3.300	3.300	3.300	3.300	3.300
1700	S (L/250)	2.200	2.200	2.200	2.200	2.200	2.053	1.493
	S (L/100)	2.200	2.200	2.200	2.200	2.200	2.200	2.200
	U	3.300	3.300	3.300	3.300	3.300	3.300	3.300
1600	S (L/250)	2.200	2.200	2.200	2.200	2.200	2.053	1.504
	S (L/100)	2.200	2.200	2.200	2.200	2.200	2.200	2.200
	U	3.300	3.300	3.300	3.300	3.300	3.300	3.300
1500	S (L/250)	2.200	2.200	2.200	2.200	2.200	2.064	1.521
	S (L/100)	2.200	2.200	2.200	2.200	2.200	2.200	2.200
	U	3.300	3.300	3.300	3.300	3.300	3.300	3.300
1400	S (L/250)	2.200	2.200	2.200	2.200	2.200	2.086	1.545
	S (L/100)	2.200	2.200	2.200	2.200	2.200	2.200	2.200
	U	3.300	3.300	3.300	3.300	3.300	3.300	3.300
1300	S (L/250)	2.200	2.200	2.200	2.200	2.200	2.119	1.578
	S (L/100)	2.200	2.200	2.200	2.200	2.200	2.200	2.200
	U	3.300	3.300	3.300	3.300	3.300	3.300	3.300
1200	S (L/250)	2.200	2.200	2.200	2.200	2.200	2.164	1.618
	S (L/100)	2.200	2.200	2.200	2.200	2.200	2.200	2.200
	U	3.300	3.300	3.300	3.300	3.300	3.300	3.300
Midrail Width (mm)		900	1050	1200	1350	1500	1650	1800

LEGEND: S = Serviceability Pressure, U = Ultimate Pressure

NOTE: This table is based on theoretical section properties, not on approved tests as specified by AS2047.

A maximum stress level of 110MPa has been applied when generating this table.

Span Table

HINGED & SLIDING 220mm COUPLED MIDRAIL - EP18288 / EP18288 (EP18287 / EP18287 SIMILAR)



Note:

Serviceability pressures have been limited to a maximum pressure of 2200Pa.

Serviceability pressures have not been limited by water performance. Where water performance is necessary, refer to Product Specification page.

This table has been based on a below midrail height of 900mm.

Above Midrail Height (mm)		Maximum Design Pressure (kPa)						
2100	S (L/250)	2.200	2.200	2.200	2.200	2.200	2.200	1.643
	S (L/100)	2.200	2.200	2.200	2.200	2.200	2.200	2.200
	U	3.300	3.300	3.300	3.300	3.300	3.300	3.300
2000	S (L/250)	2.200	2.200	2.200	2.200	2.200	2.200	1.643
	S (L/100)	2.200	2.200	2.200	2.200	2.200	2.200	2.200
	U	3.300	3.300	3.300	3.300	3.300	3.300	3.300
1900	S (L/250)	2.200	2.200	2.200	2.200	2.200	2.200	1.643
	S (L/100)	2.200	2.200	2.200	2.200	2.200	2.200	2.200
	U	3.300	3.300	3.300	3.300	3.300	3.300	3.300
1800	S (L/250)	2.200	2.200	2.200	2.200	2.200	2.200	1.643
	S (L/100)	2.200	2.200	2.200	2.200	2.200	2.200	2.200
	U	3.300	3.300	3.300	3.300	3.300	3.300	3.300
1700	S (L/250)	2.200	2.200	2.200	2.200	2.200	2.200	1.647
	S (L/100)	2.200	2.200	2.200	2.200	2.200	2.200	2.200
	U	3.300	3.300	3.300	3.300	3.300	3.300	3.300
1600	S (L/250)	2.200	2.200	2.200	2.200	2.200	2.200	1.658
	S (L/100)	2.200	2.200	2.200	2.200	2.200	2.200	2.200
	U	3.300	3.300	3.300	3.300	3.300	3.300	3.300
1500	S (L/250)	2.200	2.200	2.200	2.200	2.200	2.200	1.677
	S (L/100)	2.200	2.200	2.200	2.200	2.200	2.200	2.200
	U	3.300	3.300	3.300	3.300	3.300	3.300	3.300
1400	S (L/250)	2.200	2.200	2.200	2.200	2.200	2.200	1.704
	S (L/100)	2.200	2.200	2.200	2.200	2.200	2.200	2.200
	U	3.300	3.300	3.300	3.300	3.300	3.300	3.300
1300	S (L/250)	2.200	2.200	2.200	2.200	2.200	2.200	1.740
	S (L/100)	2.200	2.200	2.200	2.200	2.200	2.200	2.200
	U	3.300	3.300	3.300	3.300	3.300	3.300	3.300
1200	S (L/250)	2.200	2.200	2.200	2.200	2.200	2.200	1.785
	S (L/100)	2.200	2.200	2.200	2.200	2.200	2.200	2.200
	U	3.300	3.300	3.300	3.300	3.300	3.300	3.300
Midrail Width (mm)		900	1050	1200	1350	1500	1650	1800

LEGEND: S = Serviceability Pressure, U = Ultimate Pressure

NOTE: This table is based on theoretical section properties, not on approved tests as specified by AS2047.

A maximum stress level of 110MPa has been applied when generating this table.

Span Table

HINGED & SLIDING 227mm COUPLED MIDRAIL - EP18289 / EP18354 (EP18286 / EP18353 SIMILAR)



Note:

Serviceability pressures have been limited to a maximum pressure of 2200Pa.

Serviceability pressures have not been limited by water performance. Where water performance is necessary, refer to Product Specification page.

This table has been based on a below midrail height of 900mm.

Above Midrail Height (mm)		Maximum Design Pressure (kPa)						
2100	S (L/250)	2.200	2.200	2.200	2.200	2.200	2.200	1.709
	S (L/100)	2.200	2.200	2.200	2.200	2.200	2.200	2.200
	U	3.300	3.300	3.300	3.300	3.300	3.300	3.300
2000	S (L/250)	2.200	2.200	2.200	2.200	2.200	2.200	1.709
	S (L/100)	2.200	2.200	2.200	2.200	2.200	2.200	2.200
	U	3.300	3.300	3.300	3.300	3.300	3.300	3.300
1900	S (L/250)	2.200	2.200	2.200	2.200	2.200	2.200	1.709
	S (L/100)	2.200	2.200	2.200	2.200	2.200	2.200	2.200
	U	3.300	3.300	3.300	3.300	3.300	3.300	3.300
1800	S (L/250)	2.200	2.200	2.200	2.200	2.200	2.200	1.709
	S (L/100)	2.200	2.200	2.200	2.200	2.200	2.200	2.200
	U	3.300	3.300	3.300	3.300	3.300	3.300	3.300
1700	S (L/250)	2.200	2.200	2.200	2.200	2.200	2.200	1.713
	S (L/100)	2.200	2.200	2.200	2.200	2.200	2.200	2.200
	U	3.300	3.300	3.300	3.300	3.300	3.300	3.300
1600	S (L/250)	2.200	2.200	2.200	2.200	2.200	2.200	1.724
	S (L/100)	2.200	2.200	2.200	2.200	2.200	2.200	2.200
	U	3.300	3.300	3.300	3.300	3.300	3.300	3.300
1500	S (L/250)	2.200	2.200	2.200	2.200	2.200	2.200	1.744
	S (L/100)	2.200	2.200	2.200	2.200	2.200	2.200	2.200
	U	3.300	3.300	3.300	3.300	3.300	3.300	3.300
1400	S (L/250)	2.200	2.200	2.200	2.200	2.200	2.200	1.772
	S (L/100)	2.200	2.200	2.200	2.200	2.200	2.200	2.200
	U	3.300	3.300	3.300	3.300	3.300	3.300	3.300
1300	S (L/250)	2.200	2.200	2.200	2.200	2.200	2.200	1.809
	S (L/100)	2.200	2.200	2.200	2.200	2.200	2.200	2.200
	U	3.300	3.300	3.300	3.300	3.300	3.300	3.300
1200	S (L/250)	2.200	2.200	2.200	2.200	2.200	2.200	1.856
	S (L/100)	2.200	2.200	2.200	2.200	2.200	2.200	2.200
	U	3.300	3.300	3.300	3.300	3.300	3.300	3.300
Midrail Width (mm)		900	1050	1200	1350	1500	1650	1800

LEGEND: S = Serviceability Pressure, U = Ultimate Pressure

NOTE: This table is based on theoretical section properties, not on approved tests as specified by AS2047.

A maximum stress level of 110MPa has been applied when generating this table.

Span Table

HINGED & SLIDING 250mm COUPLED MIDRAIL - EP18288 / EP18354 (EP18287 / EP18353 SIMILAR)



Note:

Serviceability pressures have been limited to a maximum pressure of 2200Pa.

Serviceability pressures have not been limited by water performance. Where water performance is necessary, refer to Product Specification page.

This table has been based on a below midrail height of 900mm.

Above Midrail Height (mm)		Maximum Design Pressure (kPa)						
2100	S (L/250)	2.200	2.200	2.200	2.200	2.200	2.200	1.862
	S (L/100)	2.200	2.200	2.200	2.200	2.200	2.200	2.200
	U	3.300	3.300	3.300	3.300	3.300	3.300	3.300
2000	S (L/250)	2.200	2.200	2.200	2.200	2.200	2.200	1.862
	S (L/100)	2.200	2.200	2.200	2.200	2.200	2.200	2.200
	U	3.300	3.300	3.300	3.300	3.300	3.300	3.300
1900	S (L/250)	2.200	2.200	2.200	2.200	2.200	2.200	1.862
	S (L/100)	2.200	2.200	2.200	2.200	2.200	2.200	2.200
	U	3.300	3.300	3.300	3.300	3.300	3.300	3.300
1800	S (L/250)	2.200	2.200	2.200	2.200	2.200	2.200	1.862
	S (L/100)	2.200	2.200	2.200	2.200	2.200	2.200	2.200
	U	3.300	3.300	3.300	3.300	3.300	3.300	3.300
1700	S (L/250)	2.200	2.200	2.200	2.200	2.200	2.200	1.866
	S (L/100)	2.200	2.200	2.200	2.200	2.200	2.200	2.200
	U	3.300	3.300	3.300	3.300	3.300	3.300	3.300
1600	S (L/250)	2.200	2.200	2.200	2.200	2.200	2.200	1.879
	S (L/100)	2.200	2.200	2.200	2.200	2.200	2.200	2.200
	U	3.300	3.300	3.300	3.300	3.300	3.300	3.300
1500	S (L/250)	2.200	2.200	2.200	2.200	2.200	2.200	1.901
	S (L/100)	2.200	2.200	2.200	2.200	2.200	2.200	2.200
	U	3.300	3.300	3.300	3.300	3.300	3.300	3.300
1400	S (L/250)	2.200	2.200	2.200	2.200	2.200	2.200	1.931
	S (L/100)	2.200	2.200	2.200	2.200	2.200	2.200	2.200
	U	3.300	3.300	3.300	3.300	3.300	3.300	3.300
1300	S (L/250)	2.200	2.200	2.200	2.200	2.200	2.200	1.972
	S (L/100)	2.200	2.200	2.200	2.200	2.200	2.200	2.200
	U	3.300	3.300	3.300	3.300	3.300	3.300	3.300
1200	S (L/250)	2.200	2.200	2.200	2.200	2.200	2.200	2.023
	S (L/100)	2.200	2.200	2.200	2.200	2.200	2.200	2.200
	U	3.300	3.300	3.300	3.300	3.300	3.300	3.300
Midrail Width (mm)		900	1050	1200	1350	1500	1650	1800

LEGEND: S = Serviceability Pressure, U = Ultimate Pressure

NOTE: This table is based on theoretical section properties, not on approved tests as specified by AS2047.

A maximum stress level of 110MPa has been applied when generating this table.

Span Table

HINGED & SLIDING 280mm COUPLED MIDRAIL - EP18354 / EP18354 (EP18353 / EP18353 SIMILAR)



Note:

Serviceability pressures have been limited to a maximum pressure of 2200Pa.

Serviceability pressures have not been limited by water performance. Where water performance is necessary, refer to Product Specification page.

This table has been based on a below midrail height of 900mm.

Above Midrail Height (mm)		Maximum Design Pressure (kPa)						
2100	S (L/250)	2.200	2.200	2.200	2.200	2.200	2.200	2.081
	S (L/100)	2.200	2.200	2.200	2.200	2.200	2.200	2.200
	U	3.300	3.300	3.300	3.300	3.300	3.300	3.300
2000	S (L/250)	2.200	2.200	2.200	2.200	2.200	2.200	2.081
	S (L/100)	2.200	2.200	2.200	2.200	2.200	2.200	2.200
	U	3.300	3.300	3.300	3.300	3.300	3.300	3.300
1900	S (L/250)	2.200	2.200	2.200	2.200	2.200	2.200	2.081
	S (L/100)	2.200	2.200	2.200	2.200	2.200	2.200	2.200
	U	3.300	3.300	3.300	3.300	3.300	3.300	3.300
1800	S (L/250)	2.200	2.200	2.200	2.200	2.200	2.200	2.081
	S (L/100)	2.200	2.200	2.200	2.200	2.200	2.200	2.200
	U	3.300	3.300	3.300	3.300	3.300	3.300	3.300
1700	S (L/250)	2.200	2.200	2.200	2.200	2.200	2.200	2.086
	S (L/100)	2.200	2.200	2.200	2.200	2.200	2.200	2.200
	U	3.300	3.300	3.300	3.300	3.300	3.300	3.300
1600	S (L/250)	2.200	2.200	2.200	2.200	2.200	2.200	2.100
	S (L/100)	2.200	2.200	2.200	2.200	2.200	2.200	2.200
	U	3.300	3.300	3.300	3.300	3.300	3.300	3.300
1500	S (L/250)	2.200	2.200	2.200	2.200	2.200	2.200	2.124
	S (L/100)	2.200	2.200	2.200	2.200	2.200	2.200	2.200
	U	3.300	3.300	3.300	3.300	3.300	3.300	3.300
1400	S (L/250)	2.200	2.200	2.200	2.200	2.200	2.200	2.158
	S (L/100)	2.200	2.200	2.200	2.200	2.200	2.200	2.200
	U	3.300	3.300	3.300	3.300	3.300	3.300	3.300
1300	S (L/250)	2.200	2.200	2.200	2.200	2.200	2.200	2.200
	S (L/100)	2.200	2.200	2.200	2.200	2.200	2.200	2.200
	U	3.300	3.300	3.300	3.300	3.300	3.300	3.300
1200	S (L/250)	2.200	2.200	2.200	2.200	2.200	2.200	2.200
	S (L/100)	2.200	2.200	2.200	2.200	2.200	2.200	2.200
	U	3.300	3.300	3.300	3.300	3.300	3.300	3.300
Midrail Width (mm)		2.2	2.2	2.2	2.2	2.2	2.2	2.2

LEGEND: S = Serviceability Pressure, U = Ultimate Pressure

NOTE: This table is based on theoretical section properties, not on approved tests as specified by AS2047.

A maximum stress level of 110MPa has been applied when generating this table.

Span Table

HINGED & SLIDING 110mm MIDRAIL - EP18269 (EP18270 SIMILAR)

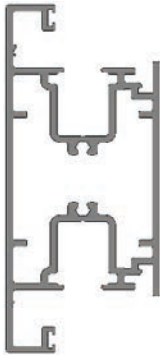

Note:

Serviceability pressures have been limited to a maximum pressure of 2200Pa.

Serviceability pressures have not been limited by water performance. Where water performance is necessary, refer to Product Specification page.

This table has been based on a below midrail height of 900mm.

Above Midrail Height (mm)		Maximum Design Pressure (kPa)						
2100	S (L/250)	3.300	3.300	3.300	2.428	1.642	1.156	0.839
	S (L/100)	3.300	3.300	3.300	3.300	3.300	2.891	2.098
	U	4.500	4.500	4.500	4.500	4.028	3.125	2.476
2000	S (L/250)	3.300	3.300	3.300	2.428	1.642	1.156	0.839
	S (L/100)	3.300	3.300	3.300	3.300	3.300	2.891	2.098
	U	4.500	4.500	4.500	4.500	4.028	3.125	2.476
1900	S (L/250)	3.300	3.300	3.300	2.428	1.642	1.156	0.839
	S (L/100)	3.300	3.300	3.300	3.300	3.300	2.891	2.098
	U	4.500	4.500	4.500	4.500	4.028	3.125	2.476
1800	S (L/250)	3.300	3.300	3.300	2.428	1.642	1.156	0.839
	S (L/100)	3.300	3.300	3.300	3.300	3.300	2.891	2.098
	U	3.300	4.500	4.500	4.500	4.028	3.125	2.476
1700	S (L/250)	3.300	3.300	3.300	2.428	1.642	1.156	0.841
	S (L/100)	3.300	3.300	3.300	3.300	3.300	2.891	2.103
	U	4.500	4.500	4.500	4.500	4.028	3.125	2.482
1600	S (L/250)	3.300	3.300	3.300	2.428	1.642	1.156	0.847
	S (L/100)	3.300	3.300	3.300	3.300	3.300	2.891	2.117
	U	4.500	4.500	4.500	4.500	4.028	3.125	2.502
1500	S (L/250)	3.300	3.300	3.300	2.428	1.642	1.163	0.857
	S (L/100)	3.300	3.300	3.300	3.300	3.300	2.906	2.142
	U	4.500	4.500	4.500	4.500	4.028	3.144	2.535
1400	S (L/250)	3.300	3.300	3.300	2.428	1.647	1.175	0.870
	S (L/100)	3.300	3.300	3.300	3.300	3.300	2.937	2.176
	U	4.500	4.500	4.500	4.500	4.043	3.182	2.580
1300	S (L/250)	3.300	3.300	3.300	2.428	1.662	1.194	0.889
	S (L/100)	3.300	3.300	3.300	3.300	3.300	2.984	2.222
	U	4.500	4.500	4.500	4.500	4.086	3.239	2.640
1200	S (L/250)	3.300	3.300	3.300	2.446	1.688	1.219	0.912
	S (L/100)	3.300	3.300	3.300	3.300	3.300	3.048	2.279
	U	4.500	4.500	4.500	4.500	4.158	3.316	2.714
Midrail Width (mm)		900	1050	1200	1350	1500	1650	1800

LEGEND: S = Serviceability Pressure, U = Ultimate Pressure

NOTE: This table is based on theoretical section properties, not on approved tests as specified by AS2047.

A maximum stress level of 110MPa has been applied when generating this table.

Span Table

HINGED & SLIDING DOOR 50mm SG MIDRAIL - EP17152

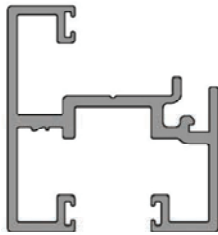

Note:

Serviceability pressures have been limited to a maximum pressure of 2200Pa.

Serviceability pressures have not been limited by water performance. Where water performance is necessary, refer to Product Specification page.

This table has been based on a below midrail height of 900mm.

Above Midrail Height (mm)		Maximum Design Pressure (kPa)						
2100	S (L/250)	2.200	2.200	1.844	1.188	0.804	0.566	0.411
	S (L/100)	2.200	2.200	2.200	2.200	1.392	1.415	1.027
	U	3.300	3.300	3.300	2.623	1.974	1.531	1.213
2000	S (L/250)	2.200	2.200	1.844	1.188	0.804	0.566	0.411
	S (L/100)	2.200	2.200	2.200	2.200	1.392	1.415	1.027
	U	3.300	3.300	3.300	2.623	1.974	1.531	1.213
1900	S (L/250)	2.200	2.200	1.844	1.188	0.804	0.566	0.411
	S (L/100)	2.200	2.200	2.200	2.200	1.392	1.415	1.027
	U	3.300	3.300	3.300	2.623	1.974	1.531	1.213
1800	S (L/250)	2.200	2.200	1.844	1.188	0.804	0.566	0.411
	S (L/100)	2.200	2.200	2.200	2.200	1.392	1.415	1.027
	U	3.300	3.300	3.300	2.623	1.974	1.531	1.213
1700	S (L/250)	2.200	2.200	1.844	1.188	0.804	0.566	0.412
	S (L/100)	2.200	2.200	2.200	2.200	1.392	1.415	1.029
	U	3.300	3.300	3.300	2.623	1.974	1.531	1.216
1600	S (L/250)	2.200	2.200	1.844	1.188	0.804	0.566	0.415
	S (L/100)	2.200	2.200	2.200	2.200	1.392	1.415	1.036
	U	3.300	3.300	3.300	2.623	1.974	1.531	1.226
1500	S (L/250)	2.200	2.200	1.844	1.188	0.804	0.569	0.419
	S (L/100)	2.200	2.200	2.200	2.200	1.392	1.422	1.048
	U	3.300	3.300	3.300	2.623	1.974	1.541	1.242
1400	S (L/250)	2.200	2.200	1.844	1.188	0.806	0.575	0.426
	S (L/100)	2.200	2.200	2.200	2.200	1.981	1.437	1.065
	U	3.300	3.300	3.300	2.623	1.981	1.559	1.264
1300	S (L/250)	2.200	2.200	1.844	1.188	0.814	0.584	0.435
	S (L/100)	2.200	2.200	2.200	2.200	2.002	1.460	1.087
	U	3.300	3.300	3.300	2.623	2.002	1.587	1.294
1200	S (L/250)	2.200	2.200	1.844	1.197	0.826	0.597	0.446
	S (L/100)	2.200	2.200	2.200	2.200	2.038	1.492	1.115
	U	3.300	3.300	3.300	2.646	2.038	1.625	1.330
Midrail Width (mm)		900	1050	1200	1350	1500	1650	1800

LEGEND: S = Serviceability Pressure, U = Ultimate Pressure

NOTE: This table is based on a combination of approved AS2047 testing data and theoretical section properties.
A maximum stress level of 110MPa has been applied when generating this table.

Span Table

HINGED & SLIDING DOOR 50mm THICK GLASS MIDRAIL - EP17153

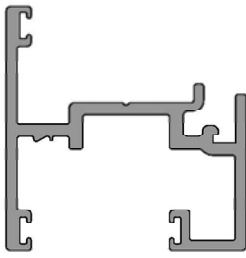

Note:

Serviceability pressures have been limited to a maximum pressure of 2200Pa.

Serviceability pressures have not been limited by water performance. Where water performance is necessary, refer to Product Specification page.

This table has been based on a below midrail height of 900mm.

Above Midrail Height (mm)		Maximum Design Pressure (kPa)						
2100	S (L/250)	2.200	2.200	1.793	1.156	0.782	0.551	0.400
	S (L/100)	2.200	2.200	2.200	2.200	1.392	1.376	0.999
	U	3.300	3.300	3.300	2.665	2.005	1.556	1.232
2000	S (L/250)	2.200	2.200	1.793	1.156	0.782	0.551	0.400
	S (L/100)	2.200	2.200	2.200	2.200	1.392	1.376	0.999
	U	3.300	3.300	3.300	2.665	2.005	1.556	1.232
1900	S (L/250)	2.200	2.200	1.793	1.156	0.782	0.551	0.400
	S (L/100)	2.200	2.200	2.200	2.200	1.392	1.376	0.999
	U	3.300	3.300	3.300	2.665	2.005	1.556	1.232
1800	S (L/250)	2.200	2.200	1.793	1.156	0.782	0.551	0.400
	S (L/100)	2.200	2.200	2.200	2.200	1.392	1.376	0.999
	U	3.300	3.300	3.300	2.665	2.005	1.556	1.232
1700	S (L/250)	2.200	2.200	1.793	1.156	0.782	0.551	0.400
	S (L/100)	2.200	2.200	2.200	2.200	1.392	1.376	1.001
	U	3.300	3.300	3.300	2.665	2.005	1.556	1.236
1600	S (L/250)	2.200	2.200	1.793	1.156	0.782	0.551	0.403
	S (L/100)	2.200	2.200	2.200	2.200	1.392	1.376	1.008
	U	3.300	3.300	3.300	2.665	2.005	1.556	1.246
1500	S (L/250)	2.200	2.200	1.793	1.156	0.782	0.553	0.408
	S (L/100)	2.200	2.200	2.200	2.200	1.392	1.384	1.020
	U	3.300	3.300	3.300	2.665	2.005	1.565	1.262
1400	S (L/250)	2.200	2.200	1.793	1.156	0.784	0.559	0.414
	S (L/100)	2.200	2.200	2.200	2.200	1.960	1.398	1.036
	U	3.300	3.300	3.300	2.665	2.013	1.584	1.285
1300	S (L/250)	2.200	2.200	1.793	1.156	0.791	0.568	0.423
	S (L/100)	2.200	2.200	2.200	2.200	1.978	1.420	1.058
	U	3.300	3.300	3.300	2.665	2.034	1.613	1.314
1200	S (L/250)	2.200	2.200	1.793	1.164	0.804	0.580	0.434
	S (L/100)	2.200	2.200	2.200	2.200	2.009	1.451	1.085
	U	3.300	3.300	3.300	2.688	2.070	1.651	1.351
Midrail Width (mm)		900	1050	1200	1350	1500	1650	1800

LEGEND: S = Serviceability Pressure, U = Ultimate Pressure

NOTE: This table is based on theoretical section properties, not on approved tests as specified by AS2047.

A maximum stress level of 110MPa has been applied when generating this table.

Span Table

HINGED & SLIDING DOOR 50mm DG MIDRAIL - EP17154

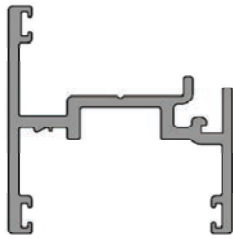

Note:

Serviceability pressures have been limited to a maximum pressure of 2200Pa.

Serviceability pressures have not been limited by water performance. Where water performance is necessary, refer to Product Specification page.

This table has been based on a below midrail height of 900mm.

Above Midrail Height (mm)		Maximum Design Pressure (kPa)						
2100	S (L/250)	2.200	2.200	1.707	1.100	0.744	0.524	-
	S (L/100)	2.200	2.200	2.200	2.200	1.392	1.310	0.951
	U	3.300	3.300	3.300	2.426	1.825	1.416	1.122
2000	S (L/250)	2.200	2.200	1.707	1.100	0.744	0.524	-
	S (L/100)	2.200	2.200	2.200	2.200	1.392	1.310	0.951
	U	3.300	3.300	3.300	2.426	1.825	1.416	1.122
1900	S (L/250)	2.200	2.200	1.707	1.100	0.744	0.524	-
	S (L/100)	2.200	2.200	2.200	2.200	1.392	1.310	0.951
	U	3.300	3.300	3.300	2.426	1.825	1.416	1.122
1800	S (L/250)	2.200	2.200	1.707	1.100	0.744	0.524	-
	S (L/100)	2.200	2.200	2.200	2.200	1.392	1.310	0.951
	U	3.300	3.300	3.300	2.426	1.825	1.416	1.122
1700	S (L/250)	2.200	2.200	1.707	1.100	0.744	0.524	-
	S (L/100)	2.200	2.200	2.200	2.200	1.392	1.310	0.953
	U	3.300	3.300	3.300	2.426	1.825	1.416	1.125
1600	S (L/250)	2.200	2.200	1.707	1.100	0.744	0.524	-
	S (L/100)	2.200	2.200	2.200	2.200	1.392	1.310	0.959
	U	3.300	3.300	3.300	2.426	1.825	1.416	1.134
1500	S (L/250)	2.200	2.200	1.707	1.100	0.744	0.527	-
	S (L/100)	2.200	2.200	2.200	2.200	1.392	1.317	0.970
	U	3.300	3.300	3.300	2.426	1.825	1.425	1.149
1400	S (L/250)	2.200	2.200	1.707	1.100	0.746	0.532	-
	S (L/100)	2.200	2.200	2.200	2.200	1.832	1.331	0.986
	U	3.300	3.300	3.300	2.426	1.832	1.442	1.169
1300	S (L/250)	2.200	2.200	1.707	1.100	0.753	0.541	0.403
	S (L/100)	2.200	2.200	2.200	2.200	1.852	1.352	1.007
	U	3.300	3.300	3.300	2.426	1.852	1.468	1.196
1200	S (L/250)	2.200	2.200	1.707	1.108	0.765	0.552	0.413
	S (L/100)	2.200	2.200	2.200	2.200	1.884	1.381	1.033
	U	3.300	3.300	3.300	2.447	1.884	1.503	1.230
Midrail Width (mm)		900	1050	1200	1350	1500	1650	1800

LEGEND: S = Serviceability Pressure, U = Ultimate Pressure

NOTE: This table is based on theoretical section properties, not on approved tests as specified by AS2047.
A maximum stress level of 110MPa has been applied when generating this table.

Span Table

INFILL PANEL - EPD0217/EPD0121



Note:

Serviceability pressures have been limited to a maximum pressure of 2200Pa.

Serviceability pressures have not been limited by water performance. Where water performance is necessary, refer to Product Specification page.

Infill Span (mm)		Maximum Design Pressure (kPa)
600	S _(L/100)	3.300 *
	U	6.000
700	S _(L/100)	3.300 *
	U	6.000
800	S _(L/100)	3.300 *
	U	6.000
900	S _(L/100)	3.300 *
	U	6.000
1000	S _(L/100)	3.300 *
	U	6.000
1100	S _(L/100)	3.164 *
	U	6.000
1200	S _(L/100)	2.437 *
	U	6.000
1300	S _(L/100)	1.917 *
	U	6.000
1400	S _(L/100)	1.535 *
	U	5.921
1500	S _(L/100)	1.248 *
	U	5.158
1600	S _(L/100)	1.028 *
	U	4.533
1700	S _(L/100)	0.857 *
	U	4.016
1800	S _(L/100)	0.722 *
	U	3.582
1900	S _(L/100)	0.614 *
	U	3.215
2000	S _(L/100)	0.526 *
	U	2.901
2100	S _(L/100)	0.455 *
	U	2.632

* Only Applies to Commercial Applications

LEGEND: S = Serviceability Pressure, U = Ultimate Pressure

NOTE: This table is based on theoretical section properties, not on approved AS2047 testing data..

A maximum stress level of 110MPa has been applied when generating this table.

Maximum Glass Thickness Table - Deadload Assessment

HINGED & SLIDING DOOR COUPLED MIDRAILS

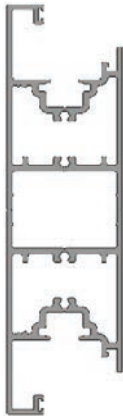

Note:

Glass thickness has been limited to 20mm according to the capacity of the suite.

These tables have been developed to assist Fabricators in making an assessment of the maximum glass thickness that the midrail member can support before it is considered unstable (deflection & stress).

Wind load and human impact requirements are not included in the tables below. A glass thickness assessment for windload and human impact must still be completed in accordance with AS1288.

Height Above Midrail (mm)	Maximum Glass Thickness with Support Blocks at 1/4 Points (mm)						
2100	20	20	20	20	20	16	12
1950	20	20	20	20	20	16	12
1800	20	20	20	20	20	20	12
1650	20	20	20	20	20	20	16
1500	20	20	20	20	20	20	16
1350	20	20	20	20	20	20	20
1200	20	20	20	20	20	20	20
Midrail Width (mm)	600	800	1000	1200	1400	1600	1800
Downward Deflection (mm)	1.0	1.3	1.7	2.0	2.3	2.7	3.0

Height Above Midrail (mm)	Maximum Glass Thickness with Support Blocks at 1/8 Points (mm)						
2100	20	20	20	20	20	20	20
1950	20	20	20	20	20	20	20
1800	20	20	20	20	20	20	20
1650	20	20	20	20	20	20	20
1500	20	20	20	20	20	20	20
1350	20	20	20	20	20	20	20
1200	20	20	20	20	20	20	20
Midrail Width (mm)	600	800	1000	1200	1400	1600	1800
Downward Deflection (mm)	1.0	1.3	1.7	2.0	2.3	2.7	3.0

NOTE: This table is based on theoretical section properties.

A deflection ratio of L/600 has been assumed, resulting in the individual deflection figures listed on the tables.

Maximum Glass Thickness Table - Deadload Assessment

HINGED & SLIDING MIDRAIL - EP14904 (EP14903 SIMILAR)

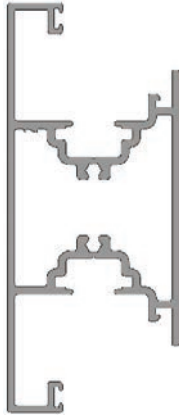

Note:

Glass thickness has been limited to 20mm according to the capacity of the suite.

These tables have been developed to assist Fabricators in making an assessment of the maximum glass thickness that the midrail member can support before it is considered unstable (deflection & stress).

Wind load and human impact requirements are not included in the tables below. A glass thickness assessment for windload and human impact must still be completed in accordance with AS1288.

Height Above Midrail (mm)	Maximum Glass Thickness with Support Blocks at 1/4 Points (mm)						
2100	20	20	20	20	16	12	10
1950	20	20	20	20	16	12	10
1800	20	20	20	20	16	12	10
1650	20	20	20	20	20	16	12
1500	20	20	20	20	20	16	12
1350	20	20	20	20	20	16	12
1200	20	20	20	20	20	20	16
Midrail Width (mm)	600	800	1000	1200	1400	1600	1800
Downward Deflection (mm)	1.0	1.3	1.7	2.0	2.3	2.7	3.0

Height Above Midrail (mm)	Maximum Glass Thickness with Support Blocks at 1/8 Points (mm)						
2100	20	20	20	20	20	20	20
1950	20	20	20	20	20	20	20
1800	20	20	20	20	20	20	20
1650	20	20	20	20	20	20	20
1500	20	20	20	20	20	20	20
1350	20	20	20	20	20	20	20
1200	20	20	20	20	20	20	20
Midrail Width (mm)	600	800	1000	1200	1400	1600	1800
Downward Deflection (mm)	1.0	1.3	1.7	2.0	2.3	2.7	3.0

NOTE: This table is based on theoretical section properties.

A deflection ratio of L/600 has been assumed, resulting in the individual deflection figures listed on the tables.

Maximum Glass Thickness Table - Deadload Assessment

HINGED & SLIDING DOOR SG MIDRAIL - EP17152

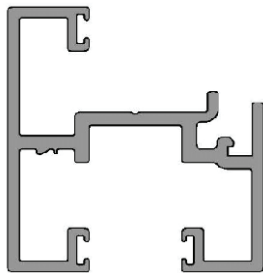

Note:

Glass thickness has been limited to 10mm according to the capacity of the suite.

These tables have been developed to assist Fabricators in making an assessment of the maximum glass thickness that the midrail member can support before it is considered unstable (deflection & stress).

Wind load and human impact requirements are not included in the tables below. A glass thickness assessment for windload and human impact must still be completed in accordance with AS1288.

Height Above Midrail (mm)	Maximum Glass Thickness with Support Blocks at 1/4 Points (mm)						
2100	12	12	8	6	4	-	-
1950	12	12	10	6	5	-	-
1800	12	12	10	6	5	-	-
1650	12	12	12	8	6	4	-
1500	12	12	12	8	6	4	-
1350	12	12	12	10	6	5	-
1200	12	12	12	10	8	5	4
Midrail Width (mm)	600	800	1000	1200	1400	1600	1800
Downward Deflection (mm)	1.0	1.3	1.7	2.0	2.3	2.7	3.0

Height Above Midrail (mm)	Maximum Glass Thickness with Support Blocks at 1/8 Points (mm)						
2100	12	12	12	12	8	6	4
1950	12	12	12	12	8	6	4
1800	12	12	12	12	10	6	5
1650	12	12	12	12	10	6	5
1500	12	12	12	12	12	8	6
1350	12	12	12	12	12	8	6
1200	12	12	12	12	12	10	6
Midrail Width (mm)	600	800	1000	1200	1400	1600	1800
Downward Deflection (mm)	1.0	1.3	1.7	2.0	2.3	2.7	3.0

NOTE: This table is based on theoretical section properties.

A deflection ratio of L/600 has been assumed, resulting in the individual deflection figures listed on the tables.

Maximum Glass Thickness Table - Deadload Assessment

HINGED & SLIDING DOOR THICK GLASS MIDRAIL - EP17153

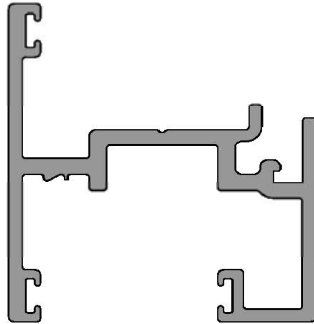

Note:

Glass thickness has been limited to 18mm according to the capacity of the suite.

These tables have been developed to assist Fabricators in making an assessment of the maximum glass thickness that the midrail member can support before it is considered unstable (deflection & stress).

Wind load and human impact requirements are not included in the tables below. A glass thickness assessment for windload and human impact must still be completed in accordance with AS1288.

Height Above Midrail (mm)	Maximum Glass Thickness with Support Blocks at 1/4 Points (mm)						
2100	16	8	6	4	-	-	-
1950	16	10	6	4	-	-	-
1800	18	10	6	5	-	-	-
1650	18	12	8	5	4	-	-
1500	18	12	8	6	4	-	-
1350	18	12	8	6	5	-	-
1200	18	16	10	6	5	-	-
Midrail Width (mm)	600	800	1000	1200	1400	1600	1800
Downward Deflection (mm)	1.0	1.3	1.7	2.0	2.3	2.7	3.0

Height Above Midrail (mm)	Maximum Glass Thickness with Support Blocks at 1/8 Points (mm)						
2100	18	16	12	8	6	4	-
1950	18	18	12	8	6	4	-
1800	18	18	12	10	6	4	-
1650	18	18	16	10	6	5	-
1500	18	18	16	12	8	5	4
1350	18	18	18	12	8	6	4
1200	18	18	18	12	10	6	5
Midrail Width (mm)	600	800	1000	1200	1400	1600	1800
Downward Deflection (mm)	1.0	1.3	1.7	2.0	2.3	2.7	3.0

NOTE: This table is based on theoretical section properties.

A deflection ratio of L/600 has been assumed, resulting in the individual deflection figures listed on the tables.

Maximum Glass Thickness Table - Deadload Assessment

HINGED & SLIDING DOOR DG MIDRAIL - EP17154

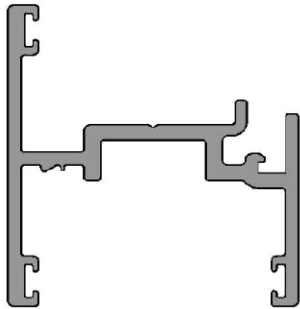

Note:

Glass thickness has been limited to 10mm according to the capacity of the suite.

These tables have been developed to assist Fabricators in making an assessment of the maximum glass thickness that the midrail member can support before it is considered unstable (deflection & stress).

Wind load and human impact requirements are not included in the tables below. A glass thickness assessment for windload and human impact must still be completed in accordance with AS1288.

Height Above Midrail (mm)	Maximum Glass Thickness with Support Blocks at 1/4 Points (mm)						
2100	12	8	-	-	-	-	-
1950	12	8	-	-	-	-	-
1800	16	8	-	-	-	-	-
1650	16	10	-	-	-	-	-
1500	20	10	-	-	-	-	-
1350	20	12	8	-	-	-	-
1200	20	12	8	-	-	-	-
Midrail Width (mm)	600	800	1000	1200	1400	1600	1800
Downward Deflection (mm)	1.0	1.3	1.7	2.0	2.3	2.7	3.0

Height Above Midrail (mm)	Maximum Glass Thickness with Support Blocks at 1/8 Points (mm)						
2100	20	16	10	-	-	-	-
1950	20	16	10	-	-	-	-
1800	20	16	12	8	-	-	-
1650	20	20	12	8	-	-	-
1500	20	20	12	10	-	-	-
1350	20	20	16	10	-	-	-
1200	20	20	16	12	8	-	-
Midrail Width (mm)	600	800	1000	1200	1400	1600	1800
Downward Deflection (mm)	1.0	1.3	1.7	2.0	2.3	2.7	3.0

NOTE: This table is based on theoretical section properties.

A deflection ratio of L/600 has been assumed, resulting in the individual deflection figures listed on the tables.