

LARGE ENOUGH TO STORE  
GOLF CLUBS, SURFBOARDS  
AND MUCH MORE



#### QUALITY ASSURANCE

All of our standard products are Quality Assured to ISO9001:2008 standards. When combined with our nation-wide distribution network, these standards make us the preferred supplier for many of Australia's largest and most respected architects and developers.

GarageSafe is part of our **HELP** brand, a social enterprise enhancing the lifestyle and independence of people with disability since 1968.

#### OUR STORY

When you become a customer of our GarageSafe Storage Solutions, you are actually buying much more than a storage solution. You become part of our **HELP** story.

GarageSafe operates as a Help Manufacturing business under Help Enterprises Limited, a reputable and long standing social enterprise organisation employing and supporting people with disability. It is a real point of difference and we take great pride in sharing our business ethos.

We are experts at what we do and continue to deliver market leading products, while contributing significantly to meaningful social outcomes. We are a proven success story.

Learn more at [helpenterprises.com.au](http://helpenterprises.com.au)



OVER BONNET  
STORAGE  
GARAGESAFE SOLUTIONS

For more information, call us on **07 3868 1765**  
or visit [garagesafe.com.au](http://garagesafe.com.au)





## WE WORK WITH ARCHITECTS & DEVELOPERS

Our GarageSafe products offer ideal storage solutions and are an added selling feature for any apartment basement or car park space. We have successfully delivered to a range of large-scale projects and multi-residential developments.

## WHAT OUR CUSTOMERS SAY

“At Mosaic, we pride ourselves on providing our clients with the best quality products available. To this end, we exclusively use GarageSafe for the over bonnet storage units in the car spaces of our developments. GarageSafe units are fully welded and reinforced, ensuring they are sturdy enough to hold heavy items. Unlike many of their competitors, GarageSafe units are constructed using aluminium, making them rust proof and light weight. Units are made to order for each specific car space, so the integrity of the storage unit is not compromised by alterations to make them fit. Although roughly three-quarters the price of their competitors, their units are fully powder-coated, giving a quality finish that is in keeping with our development design and we don’t hesitate in recommending them.”

**Mosaic is a Brisbane-based developer of boutique residential properties.**

SAFE, SECURE  
& CONVENIENT

100% ALUMINIUM GARAGE SOLUTION  
FOR INCREASED STORAGE

## MAXIMISE SPACE AND REDUCE CLUTTER

### STORAGE SOLUTIONS FOR IMPROVED SPACE

Our GarageSafe unit is a modern and sleek innovation that better utilises garage space for all storage purposes.

We take the space above the bonnet of a car and transform it into a secure, compact garage solution. The best part? It doesn’t impinge on the car park space itself or restrict the room that you need.

GarageSafe enables you to store valuables and effectively minimise unwanted mess. Our storage products offers you a neat, alternative option for housing those often bulky personal items.

### SAFEGUARDING VALUABLES

The storage unit comes with a T-style locking mechanism, securing your belongings from damage or theft. The compartment is also raised off the ground to protect possessions from fire, water, dust and vermin.

All of our products are built to last with the highest quality workmanship. That’s our promise to you.

### RANGE & DIMENSIONS

We offer three GarageSafe product sizes to suit a variety of spaces. Our most popular option is our GS1 model, with the GS2 and GS3 models offering slightly reduced heights.

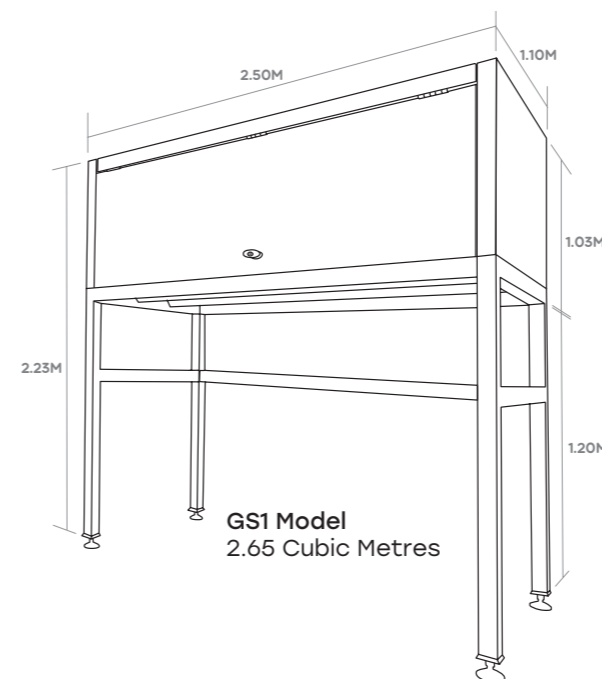

GarageSafe is a modern and sleek innovation that better utilises garage space for all storage purposes.