

Insulation



# Kooltherm® K10 G2 Soffit Board

Insulation for Concrete Soffits



- Rigid thermoset phenolic insulation
- Fibre-free, closed cell insulation core
- FM Approval to FM 4880 Standard
- Group 2 NCC fire classification
- Resistant to the passage of water vapour
- NCC and AS/NZS 4859.1:2018 compliant
- CodeMark-certified for NCC compliance
- Made in Australia



# Typical Constructions and Total R-values

## Concrete Soffit Floor / Roof Installation

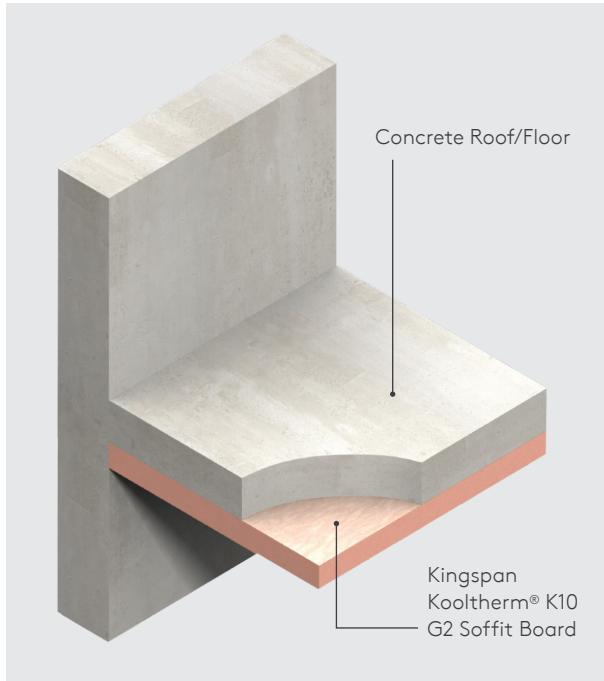

Figure 1. Concrete soffit floor/roof installation.

## Thermal Performance

**Total R-values for various thicknesses of Kingspan Kooltherm® K10 G2 Soffit Board Applicable for NCC Volume One, Class 2 to 9 buildings & NCC Volume Two, Class 1 & 10a buildings.**

Roof application, no ceiling (150 mm concrete)		
Product Thickness	Heat Flow In	Heat Flow Out
25 mm	R <sub>T</sub> 2.0	R <sub>T</sub> 1.5
30 mm	R <sub>T</sub> 2.2	R <sub>T</sub> 1.7
40 mm	R <sub>T</sub> 2.6	R <sub>T</sub> 2.2
45 mm	R <sub>T</sub> 2.9	R <sub>T</sub> 2.5
50 mm	R <sub>T</sub> 3.1	R <sub>T</sub> 2.7
60 mm	R <sub>T</sub> 3.6	R <sub>T</sub> 3.2
70 mm	R <sub>T</sub> 4.0	R <sub>T</sub> 3.6
80 mm	R <sub>T</sub> 4.5	R <sub>T</sub> 4.1
90 mm	R <sub>T</sub> 4.9	R <sub>T</sub> 4.6
100 mm	R <sub>T</sub> 5.3	R <sub>T</sub> 5.0

Roof application, suspended ceiling void greater than 300mm (150 mm concrete)		
Product Thickness	Heat Flow In	Heat Flow Out
25 mm	R <sub>T</sub> 2.5	R <sub>T</sub> 2.0
30 mm	R <sub>T</sub> 2.7	R <sub>T</sub> 2.2
40 mm	R <sub>T</sub> 3.1	R <sub>T</sub> 2.7
45 mm	R <sub>T</sub> 3.4	R <sub>T</sub> 3.0
50 mm	R <sub>T</sub> 3.6	R <sub>T</sub> 3.2
60 mm	R <sub>T</sub> 4.1	R <sub>T</sub> 3.7
70 mm	R <sub>T</sub> 4.5	R <sub>T</sub> 4.1
80 mm	R <sub>T</sub> 4.9	R <sub>T</sub> 4.6
90 mm	R <sub>T</sub> 5.4	R <sub>T</sub> 5.1
100 mm	R <sub>T</sub> 5.8	R <sub>T</sub> 5.5

**Total R-values for various thicknesses of Kingspan Kooltherm® K10 G2 Soffit Board Applicable for NCC Volume One, Class 2 to 9 buildings & NCC Volume Two, Class 1 & 10a buildings.**

Unenclosed sub-floor application (150 mm concrete)		
Product Thickness	Heat Flow In	Heat Flow Out
25 mm	R <sub>T</sub> 1.3	R <sub>T</sub> 1.4
30 mm	R <sub>T</sub> 1.5	R <sub>T</sub> 1.6
40 mm	R <sub>T</sub> 1.9	R <sub>T</sub> 2.1
45 mm	R <sub>T</sub> 2.2	R <sub>T</sub> 2.4
50 mm	R <sub>T</sub> 2.4	R <sub>T</sub> 2.6
60 mm	R <sub>T</sub> 2.9	R <sub>T</sub> 3.1
70 mm	R <sub>T</sub> 3.3	R <sub>T</sub> 3.6
80 mm	R <sub>T</sub> 3.8	R <sub>T</sub> 4.0
90 mm	R <sub>T</sub> 4.2	R <sub>T</sub> 4.5
100 mm	R <sub>T</sub> 4.6	R <sub>T</sub> 5.0

### Assumptions

The R-values shown are Total R-values for the building element as required by the Energy Provisions of the National Construction Code 2022, calculated in accordance with AS/NZS 4859.2:2018 & NZS 4214:2006. Kingspan Kooltherm® products are manufactured, tested and packaged in conformance with AS/NZS 4859.1:2018

# Product Details

## Product Description

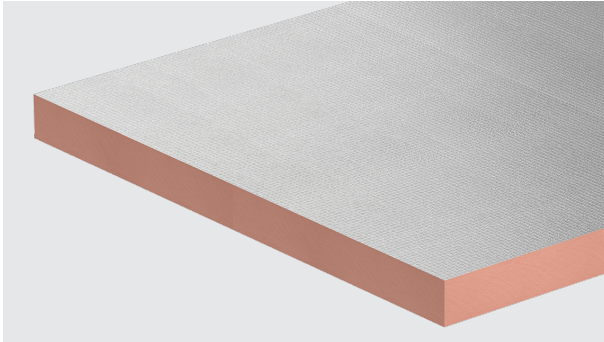

Figure 2. Kingspan Kooltherm® K10 G2 Soffit Board.

Kingspan Kooltherm® K10 G2 Soffit Board is a fibre-free rigid thermoset, closed cell phenolic insulation core, sandwiched between an upper tissue-based facing and a lower facing of reflective aluminium foil autohesively bonded to the insulation core during manufacture.

### Product Data

Declared Thermal Conductivity ( $\lambda$ -value) AS/NZS 4859.1:2018 / ASTM C518-2017	0.022 W/m.K at 23°C (Insulant Thickness $\geq$ 45 mm) 0.023 W/m.K at 23°C (Insulant Thickness 25 - 44 mm)
Emittance (Foil Face) ASTM C1371:2015	E0.05
Product Dimensions	2400 mm x 1200 mm (2.88 m <sup>2</sup> )
Nominal Product Thickness	25, 30, 40, 45, 50, 60, 70, 80, 90 mm

For a white finish or other customised finishes and facings please refer to the 'Kingspan Kooltherm® K10 G2W White' and the 'Kingspan Kooltherm® K10 Plus' product brochure respectively.

## Product R-value

Nominal Product Thickness	Declared Product R-value at 23°C
25 mm	R1.10
30 mm	R1.30
40 mm	R1.75
45mm	R2.05
50 mm	R2.30
60 mm	R2.75
70 mm	R3.20
80 mm	R3.65
90 mm	R4.10
100 mm	R4.60

## Specification Guide

### Kingspan Kooltherm® K10 G2 Soffit Board

The soffit insulation shall be CodeMark-certified Kingspan Kooltherm® K10 G2 Soffit Board \_\_\_ mm thick, Group 2, with a tested in accordance with AS 5637.1:2015 SMOGRA<sub>RC</sub> of not more than 30 m<sup>2</sup>/s<sup>2</sup> x 1000, comprising a rigid thermoset phenolic insulation core with an upper tissue-based facing and a lower facing of reflective aluminium foil, manufactured under a management system certified to ISO 9001:2015, ISO 14001:2015, ISO 45001:2018 and ISO 50001:2018 by Kingspan Insulation Pty Ltd and shall be installed in accordance with the instructions issued by them.

A Project Specific Warranty provided by Kingspan Insulation must be submitted.

# Product Details

## Standards and Approvals

Kingspan Kooltherm® K10 G2 Soffit Board is manufactured to the highest standards and certified under the following management systems:

Standard	Management System
ISO 9001:2015	Quality Management
ISO 14001:2015	Environmental Management
ISO 45001:2018	Occupational Health and Safety
ISO 50001:2018	Energy Management

## Product Testing

Characteristic	Standard	Result
Compressive Stress (Insulant)	AS 2498.3:1993	On average exceeds 100 kPa at 10% compression
Water Vapour Transmission	ASTM E96 – Part B 2016	> 35 MN.s/g

## Fire Performance

Test	Test Method	Result
Early Fire Hazard Properties. (Ignitability, Flame spread, Heat release, Smoke release)	AS 1530.3:1999	Spread of Flame Index: 0 Smoke Development $\leq 3$
NCC Group Number	AS 5637.1:2015 / AS ISO 9705:2003 (R2016)	Group 2
SMOGR <sub>RC</sub>	AS ISO 9705:2003 (R2016)	$\leq 30 \text{ m}^2/\text{s}^2 \times 1000$
FM Class No. 4880*	UBC 26-3	Class 1

\* This approval is valid for ceiling / soffit installation only, with non-combustible walls. Please contact us for correct installation instructions.

## FM Approval



Kingspan Kooltherm® K10 G2 Soffit Board is certified to Approval Standard FM 4880 for interior finish material solutions to ceilings. Thicknesses 25mm to 119mm are covered by the FM Approval.

Further details of the FM Approval listing for Kingspan Kooltherm® K10 G2 Soffit Board are published on the FM Approvals Approval Guide website at: [www.approvalguide.com](http://www.approvalguide.com).

To view the listing, search Keyword(s): Kooltherm K10 G2. Please contact the Kingspan Insulation Technical Services department for further confirmation.

## Durability

If correctly applied, Kingspan Kooltherm® products can be expected to have a long life of service.

Their durability depends on the supporting structure and the conditions of its use.

Kingspan Kooltherm® products are warranted for a period of 10 years for both residential and commercial installations.\*

\* Subject to the terms of the complete Kingspan Kooltherm® warranty document which is available upon request or downloadable from [www.kingspaninsulation.com.au](http://www.kingspaninsulation.com.au)

## Environmental Data

Aspect	Characteristic
Re-usability	Re-usable if removed with care (long term of service expected)
Water Use	No water used in Kingspan Insulation's manufacturing process

# Installation Instructions

## Fixing Directly to Concrete Soffits

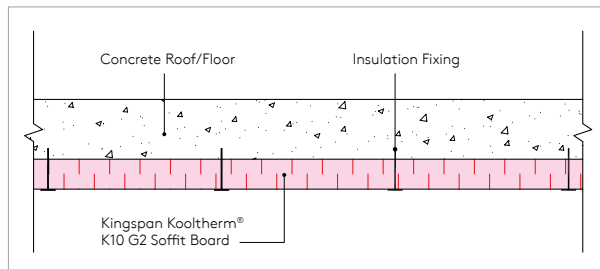

Figure 3. Side elevation - Concrete Soffit with Kingspan Kooltherm® K10 G2 Soffit Board.

Kingspan Kooltherm® K10 G2 Soffit Board can be fully restrained to a concrete soffit by the use of minimum eleven appropriate insulation fasteners with a minimum head diameter of 35 mm.

1. The fasteners should be evenly distributed over the whole area of the board and designed to provide suitable restraint for the project requirements. Consultation with the chosen fastener supplier is recommended.
2. Board joints can be either staggered (see Figure 5) or squared (see Figure 6) and taped with 96 mm wide silver Kingspan Insulation Tape. Four fasteners along each length - no less than 50 mm - no more than 150 mm from edge of board, three fasteners along the middle (offset from edge positions as per diagram Figure 4).
3. Where the board may be subject to external wind pressure, the requirement for additional fixings should be assessed in accordance with appropriate Australian wind load standards.
4. Consideration should be given to the material the fixing is made from and should be deemed appropriate for application, exposure and fire rating by the fixing manufacturer.

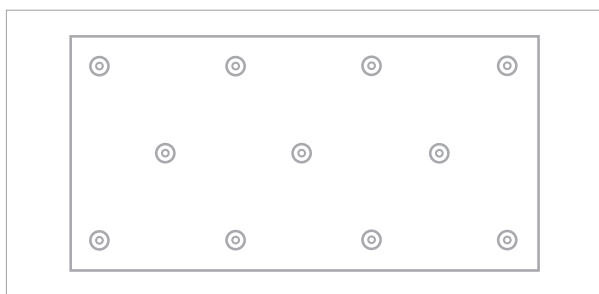

Figure 4. Fastener pattern (11 per board).  
Board size to 2400 mm x 1200 mm - 3.81 fixings / m<sup>2</sup>

## Why 11 fixings?

Best practice determines that any rigid board insulation, not just Kingspan Kooltherm® K10 G2 Soffit Board, should be fixed with 11 mechanical fixings for very good reasons:

- Excessive movement occurring between boards, can place undue stress on the foil tape at the joint and result in peeling.
- In any concrete forming, there will be an uneven surface throughout the slab.
- Where concrete formwork is joined it is normal to have ridges of up to 3 mm which makes the concrete surface uneven.
- An insulation board held horizontally may bow in time like any other sheet material under its own weight, which can look unsightly and cause tape to peel off.
- Some direct fastener solutions can have a high failure rate, which may not be apparent to the installer at first.
- It provides a proven robust fire safe solution. It limits the ability for the foil facer to peel off in a fire event and obstruct fire sprinklers. It also reduces the potential for falling debris, i.e. chunks of insulation falling, causing a hazard for firefighters entering the building and occupants exiting the building.
- Kingspan's 11 fixing pattern is supported by FM Approvals. Less fixings would not be approved by FM and could cause insurance problems.

Using 11 fixings ensures that the insulation board has a strong and permanent fix under the concrete soffit and that it is not compromised by any of the above issues.

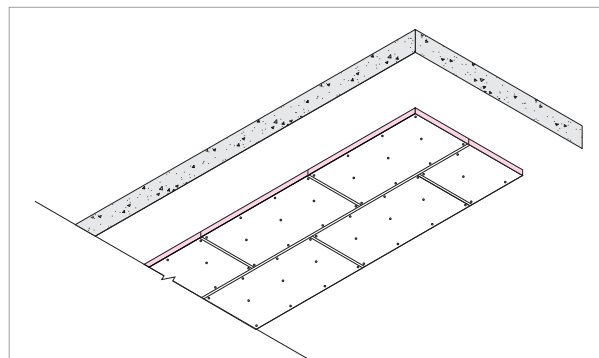

Figure 5. Board joints staggered.

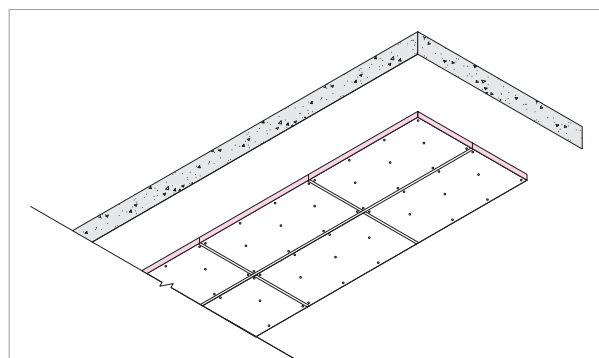

Figure 6. Board joints squared.

- There will always be differential expansion and contraction between any rigid insulation material and adjacent building elements due to varying moisture content and temperature.

# Installation Instructions

These best practice recommendations are a result of over 30 years of Kingspan Insulation experience in soffit applications and is supported by FM certification.

Companies promoting less fixings, as low as 6 or 7, in the market have not been in the market for long and have not yet expired their warranty periods.

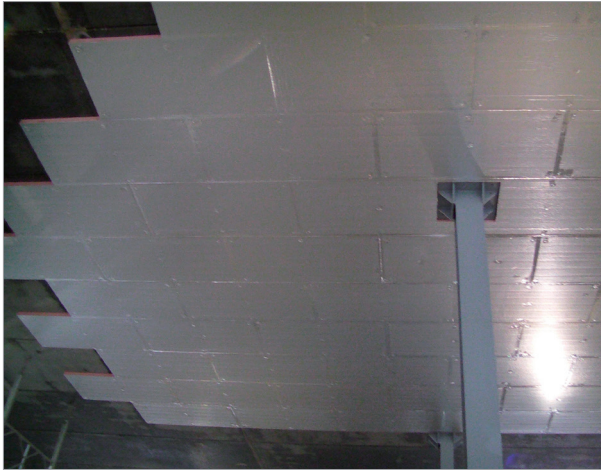

## Proprietary Grid Systems

Kingspan Kooltherm® K10 G2 Soffit Board can also be fixed to a proprietary grid system comprising metal furring bars or timber battens. For further information regarding proprietary grid system specifications, please contact the Kingspan Insulation Technical Service Department.

For advice on ancillary materials, such as fixings and tapes please contact our Technical Services Department.

## Installation around Fire Collars

1. Fitting Kingspan Kooltherm® K10 G2 Soffit Board tight to the fire collar is recommended to reduce the effects of thermal bridging through the slab.
2. Do not cover the face of the fire collar. For fire collars to activate in a fire situation the front face needs to be exposed. This is particularly important when using cast-in collars as the face will be flush with the concrete and it would be easy to cover with the insulation board.

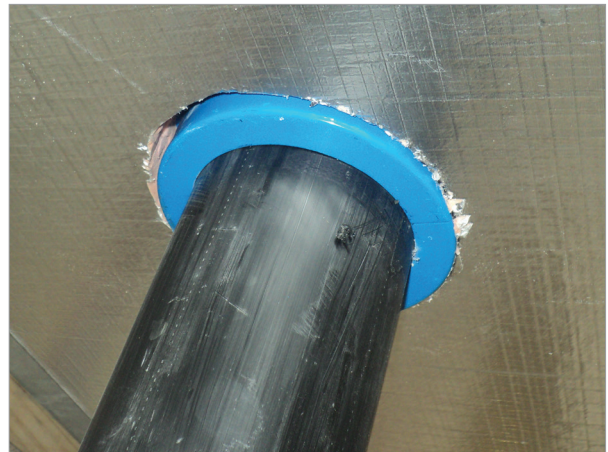

Figure 7. Penetration example - Kingspan Kooltherm® K10 G2 Soffit Board installed tight around the fire collar and HDPE service pipe.



Scan to see installation video  
"Fixing Directly to Concrete Soffits"

# Other Information

## General

### Cutting

Cutting should be carried out either by using a fine toothed saw, or by scoring with a sharp knife, snapping the board over a straight edge and then cutting the facing on the other side. Ensure accurate trimming to achieve close-butting joints and continuity of insulation.

### Taping

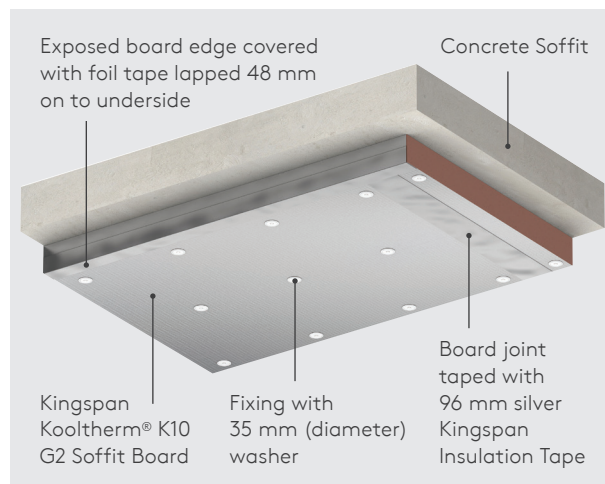

Figure 8.

For all fixing methods board joints should be taped with 96 mm wide silver Kingspan Insulation Tape (please refer to brochure 'Kingspan Insulation Tape' for further information).

1. Firstly, ensure that the climate conditions are suitable for the tape being used as well as the product the tape is to be applied too.
2. The surface of the Kingspan Kooltherm® to which aluminium foil tape is being applied, should be free of dust, dirt or oils. In any case, the surface should be cleaned with a dry cloth before application of the tape.
3. The release liner on the tape should be removed 300 - 600 mm at a time and the adhesive face pressed firmly onto the insulation facing. Care should be taken not to stretch the tape tightly as this will create buckles and voids in the contact area.
4. Care must also be taken to apply the tape over the centre of the join so that there is adequate area on both sides of the joint for the tape to bond. Uneven width distribution also puts additional shear stress on the smaller side of the butt joint.
5. The tape should then be wiped firmly from the centre out (like wallpaper) with a plastic squeegee. The more pressure that is applied, the more surface contact will be reached, therefore, the greater the bond surface.
6. The tape should then be cut and fitted with a knife and scissors. The same wiping instructions should then be used as above.

In the absence of other protection exposed board edges should be protected by silver Kingspan Insulation Tape with a minimum 48 mm wide overlap onto the board face (see Figure 8) or alternatively use a proprietary metal c-section.

### Packaging

According to quantity, the boards are supplied in packs, labelled and shrink-wrapped in polythene.

## Handling and Storage

### Storage

The packaging of Kingspan Kooltherm® should not be considered adequate for long term outdoor protection. Ideally boards should be stored inside a building. If, however, outdoor storage cannot be avoided then the boards should be stacked clear of the ground and covered with an opaque polythene sheet or weatherproof tarpaulin. Boards that have been allowed to get wet should not be used.

### Resistance to Solvents

The insulation core is resistant to short-term contact with petrol and with most dilute acids, alkalis and mineral oils. However, it is recommended that any spills be cleaned off fully before the boards are installed. Ensure that safe methods of cleaning are used, as recommended by suppliers of the spilt liquid. The insulation core is not resistant to some solvent-based adhesive systems, particularly those containing methyl ethyl ketone. Adhesives containing such solvents should not be used in association with this product. Damaged boards or boards that have been in contact with harsh solvents or acids should not be used.

## Safety Information

Kingspan Insulation products are chemically inert and safe to use. A Product Safety Information sheet is available from Kingspan Insulation Pty Ltd.

Please note that the reflective surfaces on this product are designed to enhance their thermal performance. As such, they will reflect light as well as heat, including ultraviolet light. Therefore, if these boards are being installed during bright or sunny weather, it is advisable to wear UV protective sunglasses or goggles and if the skin is exposed for a significant period of time, to protect bare skin with a UV block sun cream.

**Foil facings are conductive to electricity – avoid contact with un-insulated electrical cables and fittings.**

Installation must be in accordance with AS 3999:2015 Bulk Thermal Insulation Installation and AS 3000:2018 Electrical Installations (Wiring Rules).

---

# Contact Details

---

## Australia

Kingspan Insulation Pty Ltd  
T: 1300 247 235  
E: [info@kingspaninsulation.com.au](mailto:info@kingspaninsulation.com.au)  
[www.kingspaninsulation.com.au](http://www.kingspaninsulation.com.au)

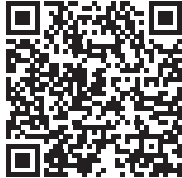

---

© Kingspan, Kooltherm, KoolDuct, Air-Cell, GreenGuard, Thermakraft and the Lion Device are Registered Trademarks of the Kingspan Group plc in Australia and other countries. All rights reserved. © Kingspan Insulation Pty Ltd.

Kingspan Insulation Pty Ltd reserves the right to amend product specifications without prior notice. The information, technical details and fixing instructions etc. included in this literature are given in good faith and apply to uses described. Recommendations for use should be verified as to the suitability and compliance with actual requirements, specifications and any applicable laws and regulations. For other applications or conditions of use, Kingspan Insulation offers a Technical Advisory Service the advice of which should be sought for uses of Kingspan Insulation products that are not specifically described herein. Please check that your copy of the literature is current by contacting us or visiting <https://www.kingspan.com/au/en/products/insulation/roof-insulation/kooltherm-k10-g2-soffit-board/>

