

Sentinel KL Boom Gate

Heavy duty 12 metre boom gate

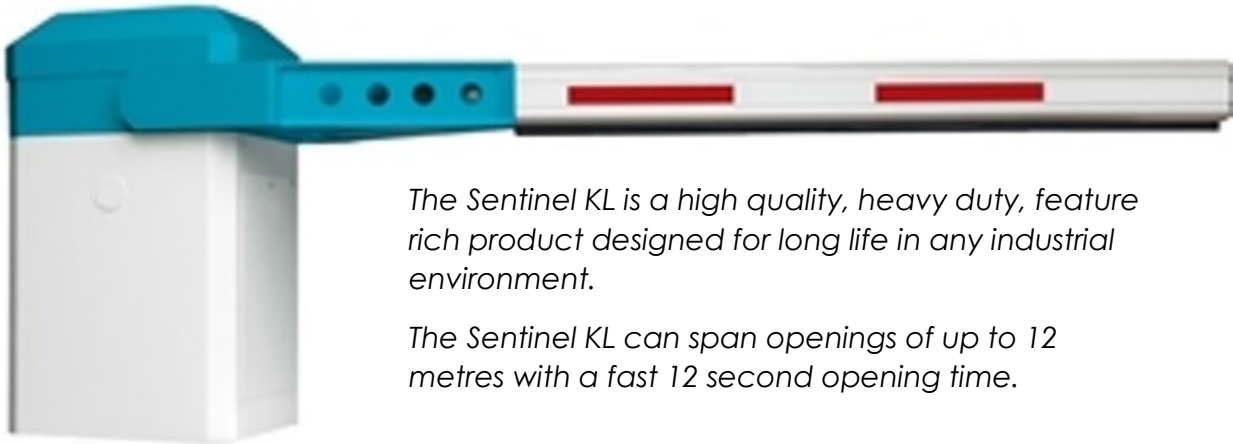

The Sentinel KL is a high quality, heavy duty, feature rich product designed for long life in any industrial environment.

The Sentinel KL can span openings of up to 12 metres with a fast 12 second opening time.

Companies with large vehicles or rail sidings often require boom gates to restrict access to large openings. Most conventional boom gates have a maximum capacity of 6 metres, the Sentinel KL can span openings of up to 12 metres.

With its opening time of 12 seconds it is much faster than a sliding gate and allows quicker vehicle throughput. The boom arm is fitted with 200 mm diameter flashing lights which are visible from long distances even in daylight.

The industrial grade boom gate cabinet is made with a steel electroplated inner frame with bolt on aluminium covers. With a 100% duty cycle, a boom gate that weighs 547KGs and a boom arm that is 170 mm x 140 mm you are assured of a product that can withstand any heavy duty environment.

Featuring a sophisticated fully programmable control panel the Sentinel KL can be set to suit any operating parameters. It has facilities for up to 3 loop detectors, directional vehicle counting, traffic lights and boom pole missing alarm.

The Sentinel KL boom gate can be remotely controlled by computerised access control systems using the TCP/IP or RS485 protocol.

Sentinel KL features include:

Safety is a priority when large vehicles are manoeuvring around the boom gates and the KL has excellent safety features

- Electronic safety edge fitted to the boom pole reverses the boom pole if obstructed
- Ground loop detectors and PE safety beams can sense when a vehicle or pedestrian is underneath the boom pole and prevent closing
- Flashing safety lights or sirens can be activated when the boom gate controller receives a signal to close and after a variable time delay the boom pole will close.

Technical Specifications

Specifications	Sentinel KL Boom Gate
Opening Speed	9 - 12 Seconds
Boom Length	9 - 12 Metres
Mains Supply	230v / 50 Hz
Max. Current	10A
Duty Cycle	100%
Temperature Range	-10°C to +70°C
Noise Level	≥ 60 Db (A)

Dimensions

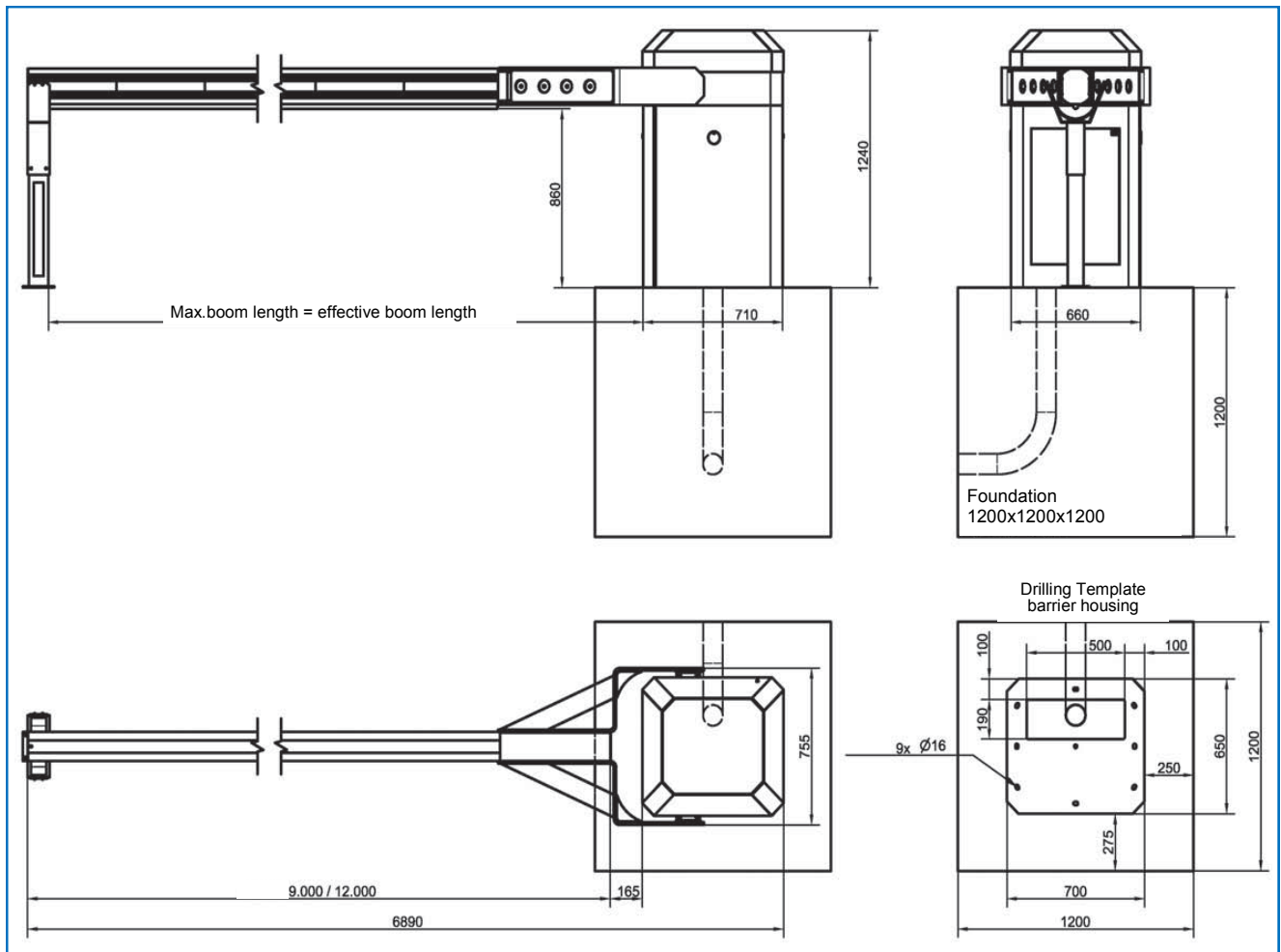

Rotech supply all forms of door and gate automation

Vehicle Access Control

- Booms Gates
- Sliding Gates
- Swing Gates
- Industrial Door Openers
- Solar Powered Gate Openers

Pedestrian Access Control

- Full Height Turnstiles
- Waist Height Turnstiles
- Supermarket Gates/Turnstiles
- Wheelchair Access Gates
- Rapid Access Gates

Fast | Safe | Secure

For more information: t: +61 07 3205 1123 | www.rotech.com.au | e: info@rotech.com.au

V0116