



InSinkErator® Steaming Hot Water Taps **Smart technology for the modern kitchen**

InSinkErator® steaming hot and ambient filtered water taps don't just bring contemporary style to the kitchen sink – they bring ultimate convenience and efficiency to simplify your life in the kitchen.

At the flick of a lever, our Steaming Hot Water Taps are ready to dispense filtered, near-boiling water – the perfect temperature for making hot drinks, speeding up the preparation of pasta or vegetables, cleaning dishes and a host of other kitchen tasks. Our hot/cold models also dispense ambient filtered water for the best tasting and safest drinking water on demand. No kettles, no clutter, no fuss... just near-boiling and ambient filtered water at your fingertips.

Once you have one, you'll wonder how you ever did without it.

Ultimate Convenience

Food and drink

- Make tea, coffee and other hot drinks
- Prepare pasta and rice
- Blanche vegetables
- Create gravies, sauces and soups
- Warm baby bottles
- Reduce water wasted waiting for it to run warm
- Assisting with clean up

HC1100 & GN1100 Series



HC1100 Features

- Dispensers hot and ambient cold filtered water
- Two lever tap
- 5 Micron filter
- 2 year warranty



GN1100 Features

- Steaming hot filtered water
- Single lever tap
- 5 Micron filter
- 2 year warranty

**INSINKERATOR® 1100 SERIES
STEAMING HOT WATER TAPS
SPECIFICATION SHEET**

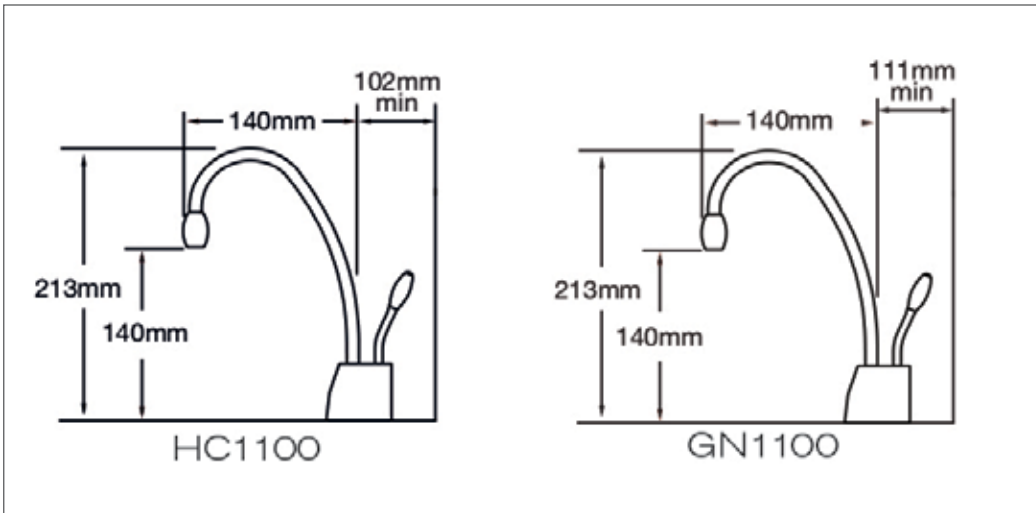

Tap Specification	HC1100	GN1100
Hot Valve	Instant self closing	
Cold Valve	Manual return	n/a
Weight	Approximately 4.4kg	
Required Hole Diameter	35mm-38mm	35mm-38mm

NEOTANK™
Compact.
Reliable.
Innovative.

Our next generation Neotank features a compact design that is affixed to the cupboard wall conserving space usage. This upgraded tank has precise adjustable temperature control up to 98 degrees celsius and has been designed with a welded construction, eliminating seals to improve lifespan.

The 2.5L capacity allows the consumer to heat only what they need while conserving energy for environmental stewardship. The NeoTank offers quiet energy efficient operation and the revolutionary new design gives consumer peace-of-mind through quality and reliability.



InSinkErator. 471 Mountain Hwy, Bayswater VIC 3153.
Australian Sales Tel:1300 136 205, Fax: 03 9720 3178.

InSinkErator reserves the right to change product specifications without prior notice.
All products are for household use: usage in commercial situations is not covered by warranty.

The Emerson logo is a trademark and service mark of Emerson Electric Co.
InSinkErator is a division of Emerson Electric Co.

Find us on facebook at facebook.com/insinkeratorAU

