

LOUVRES

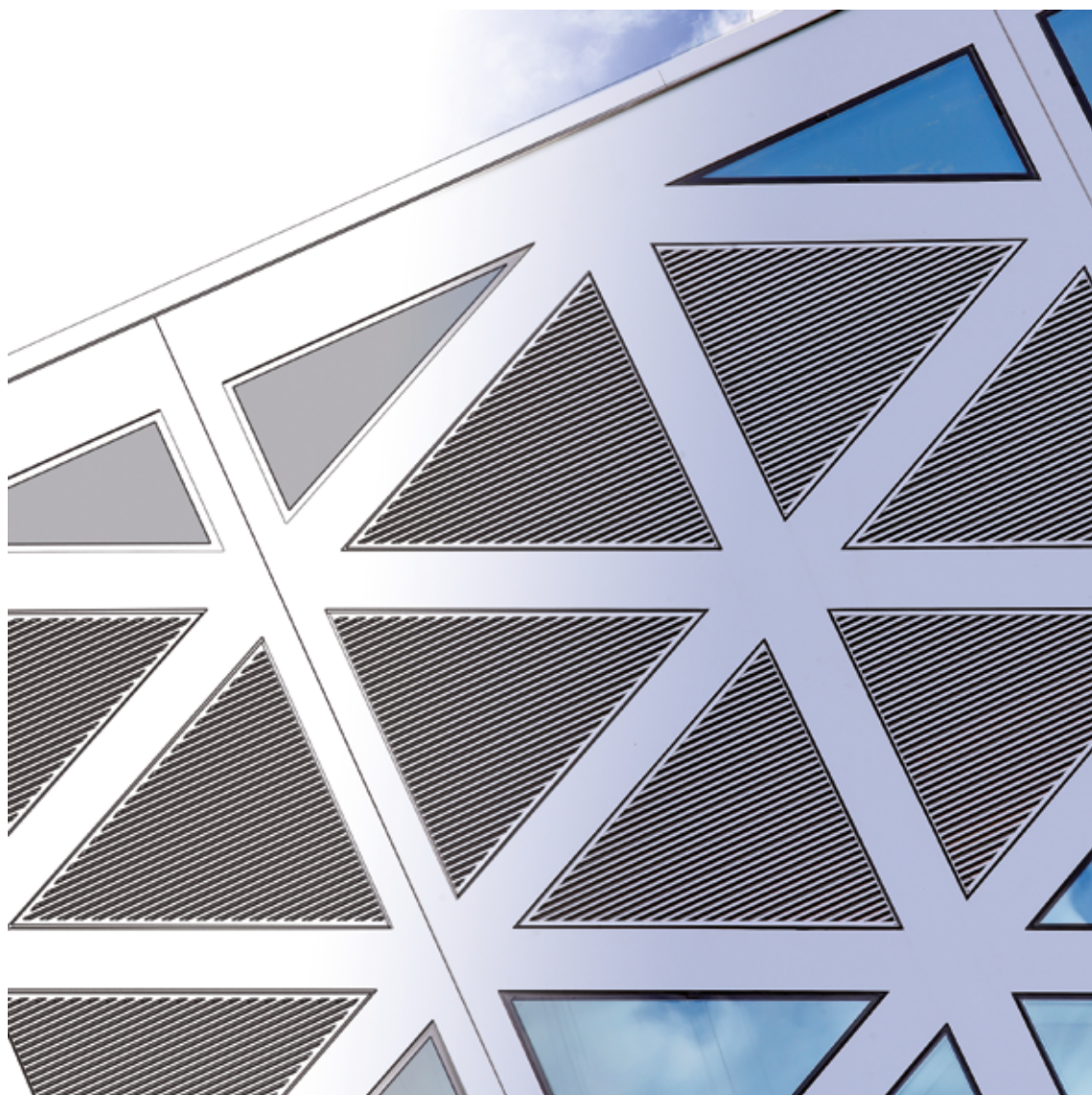

OUR MISSION

Creating healthy spaces



Paul Renson

Renson® specialises in ventilation, sun protection, and terrace coverings. With experience dating back to 1909, and a team of around 1600 employees, we have been developing solutions aimed at achieving a healthy and comfortable living and work environment for the consumer. In doing this, we take into account energy-efficiency requirements and the use of renewable energy, as well as maintenance friendliness. We develop innovative products and systems, and offer total solutions that can make each house a healthy and comfortable home.” This is what underlies our baseline, ‘Creating Healthy Spaces’.

‘In addition, we also think of the aesthetic value of each building. Thus, our ventilation and sun protection systems can be integrated almost invisibly. Our terrace coverings and aluminium blades for façade cladding provide clear accents, offering added value to the architecture. Inside, we ensure that doors are integrated invisibly without conspicuous frames or visible hinges.”

Discover how Renson® products can optimise the comfort experience within a contemporary design.

“We not only develop innovative solutions, but we also think of ways to contribute aesthetic added value to each building.”



TABLE OF CONTENTS

INTRODUCTION

General	7
Online louvre selector	9
Intensive ventilation	10
Selection criteria	11
Options	16

OVERVIEW OF THE RANGE 18

PRODUCTS

Built-in wall louvres ALUMINIUM

411	Wall louvre, standard series	22
411R	Round wall louvre	26
412	Wall louvre with chevron section blades	28
412R	Round wall louvre with chevron section blades	30
421	Wall louvre, heavy-duty series	32
421R	Round wall louvre, heavy-duty series	34
422	Wall louvre with chevron section blades, heavy-duty series	36
427	Wall louvre, extra-heavy-duty series, with adjustable blades	38
451	Wall louvre, heavy-duty series	40
453	Wall louvre, heavy-duty series, with aluminium coil blades	42
457	Wall louvre, heavy-duty series	46
468 SA	Sand trap louvre	46
480	High-airflow wall louvres	48
481	Wall louvre, heavy-duty series	50
511	Wall louvre, galvanised steel	52
521	Wall louvre, heavy-duty series, galvanised steel	54
621	Wall louvre, stainless steel	56

Weatherable louvres ALUMINIUM

450	Extreme weatherable louvre	60
450V	Extreme weatherable louvre	60
452	Wall louvre, heavy-duty series with chevron section blades	62

452V	Wall louvre, heavy-duty series with vertical chevron section blades	64
475	Louvre with excellent weatherability properties, ideal for discharge applications	66
475GL	Glazed-in louvre with excellent weatherability properties, ideal for discharge applications	68
491	"Storm" wall louvre	70

Surface-mounted louvres ALUMINIUM

431	Surface-mounted wall louvre	72
431R	Round louvre without frame	76
432	Surface-mounted, removable louvre with frame	76
433	Pressure-relief damper	78

Glazed-in louvres ALUMINIUM

414	Glazed-in louvre	80
414R	Round glazed-in louvre	82
414VA	Controllable louvre	84
414THF	Thermally insulated window louvre	86
415	Glazed-in louvre with chevron section blades	88
415R	Round louvre with chevron section blades	90
415VA	Controllable louvre with chevron section blade	92
424	Glazed-in louvre, heavy-duty series	94
428	Glazed-in louvre with chevron section blades, heavy-duty series	96
483	High-airflow glazed-in louvre	98
484	Glazed-in louvre, heavy-duty series	100
494	Glazed-in "storm" louvre	102
427GL	Glazed-in louvre with adjustable blades, extra-heavy-duty series	104

Acoustic louvres ALUMINIUM

445/86	Acoustic wall louvre, pitch 60	106
446/150	Acoustic wall louvre, pitch 150	108
446/225	Acoustic wall louvre, pitch 150	110
446/300	Acoustic wall louvre, pitch 150	112
447/150	Acoustic wall louvre, pitch 170	114
447/225	Acoustic wall louvre, pitch 170	116

Burglar resistance louvres <small>ALUMINIUM</small>			SQair	Extractor vent	162
421RC2	Burglar resistance louvre class RC2	118	Puro	Design extraction louvre	164
424RC2	Burglar resistance built-in louvre class RC2	120	Square	Design extraction louvre	164
431RC2	Fall-proof and burglar-resistant surface-mounted louvre	122	Diagonal	Design extraction louvre	164
421RC3	Burglar resistance louvre class RC3	124	Aqua	Design extraction louvre	165
423RC4	Burglar resistance louvre class RC4	126	Artist	Design extraction louvre	165
			Deco	Design extraction louvre	165
Louvre box <small>ALUMINIUM</small>			Circular punched grilles <small>ALUMINIUM</small>		
440	Turret	128	435R	Circular built-in punched grille	166
Floor grilles <small>ALUMINIUM</small>			436	Punched grille	168
311	Convector grille	130	437	Punched grille with frame	169
371	Floor grille, heavy-duty series	132	438	Punched grille, stainless steel	170
Linear bar grilles <small>ALUMINIUM</small>			439	Punched grille, edge-raised	171
392	Linear bar grille	134	Ventilation grilles <small>ALUMINIUM</small>		
394	Linear bar grille for self-assembly	136	381	Built-in ventilation grille	172
Door grilles <small>ALUMINIUM</small>					
461	Door grille	138			
468AK/1	Interior acoustic wall louvre	140			
468AK/2	Interior acoustic door grille	142			
461AK Silendo®	Acoustic door grille for residential sector	144			
469 Invisido®	Discreet door grille	146			
Fire-resistant louvres <small>ALUMINIUM</small>					
Incendo® 464	Fire-resistant louvre with angled blades	148			
465	Fire-resistant louvre with angled blades	150			
466	Fire-resistant louvre with horizontal blades	152			
467	Fire-resistant louvre with horizontal blades, in solid concrete wall 120'	154			
Controllable cavity wall louvres					
442	Cavity wall ventilator	156			
441	Register with frame	157			
4032	Register to fix	158			
XD	Design extraction louvre	160			



GENERAL

MATERIAL

All louvres in this brochure have been manufactured from aluminium profiles **AlMgSi 0,5** (according EN 12020-2).

- **Light, strong & durable**

Aluminium is a very light metal, about one third of the weight of steel. This results in a lighter product, more efficient use of transport, high loading capacity, lower material usage...

- **100% recyclable**

Aluminium is 100% recyclable without loss of quality. The energy used to fuse the product takes only about 5% of the energy used to produce the original product.

Did you know that 75% of the produced aluminium is still circulating the world?



FINISHING

By nature, aluminium generates a natural oxide coating and it is very corrosion resistant. And aluminium has resistance against UV radiation from sunlight and can easily resist to temperature variations. Various types of surface treatments improve its corrosion resistance even further.

- **Anodisation:** A layer thickness of 20 microns is applied as standard. For applications in an aggressive atmosphere, a layer thickness of 25 microns is recommended. Anodisation is usually done using a natural shade of grey [F1], but can also be done in a limited number of other colours [Euras]. Colour differences are possible with anodisation, both within the same surface and between different pieces. These differences mainly occur with colour anodisation.

- **Powder-coating:** The choice of a very wide colour palette and the minimal risk of colour differences are two important reasons for choosing powder-coatings. Powder-coating is standard with a layer thickness of 40 microns. Depending on the environment, different pre-treatments can be applied:

- Standard pre-treatment

Correct pre-treatment of the aluminium is essential for optimum quality. This pre-treatment is carried out in accordance with the applicable directives and consists of a sequence of staining, degreasing, rinsing, and the application of a conversion layer.

- Pre-treatment conform Seaside Quality A

We recommend a pre-treatment in accordance with Seaside Quality A for applications in aggressive environments (e.g. coastal regions, in industrial atmospheres, etc.). This halves the risk of filiform corrosion under the paint in comparison with standard coated profiles.

- Pre-treatment before anodizing

For applications in highly aggressive environments (e.g. coastal regions, on the coastline, in industrial atmospheres, etc.), we recommend pre-treatment before anodizing. This halves the risk of filiform corrosion under the paint in comparison with standard coated profiles.

- **Standard colours**

Some louvre types are in stock in standard dimensions and colours. The available models for the relevant products are listed in the brochure.

- **Gloss level**

Most powder colours are available in textured, matt, or glossy, where

- Glossy: gloss level 70%

- Matt: gloss level 30%

MAINTENANCE

Besides cleaning, aluminium does not require any maintenance or repair of its surface finishing. Details about the necessary cleaning frequency and methods can be found in the warranty terms and conditions.

WARRANTY

Renson gives a basic 10-year warranty on all louvres. The gloss of powder coated parts is limited to 5 years. Motors are limited to 2 years. More details and modalities can be found in the warranty terms and conditions.

PACKING

Louvres will be packed in a transparent plastic foil. In case the louvre is larger than 500 mm on one side, expanded polystyrene will be added on the framework as protection. For very large louvres, an additional cardboard packaging ensures the correct protection.

GENERAL

LOUVRE WITH STRENGTHENING SUPPORT

Remark: a strengthening support will be provided for a louvre wider than 700 mm.

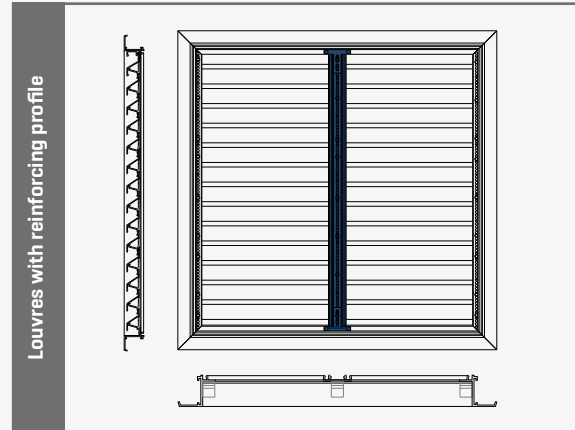

CONSTRUCTION TECHNICAL CHARACTERISTICS DIMENSIONS

- Surface-mounted louvres, flangeless louvres, and glazed-in louvres are characterised by their overall width and height dimensions.
- Built-in louvres are characterised by the overall width and height dimensions of the section to be built in. The dimensions of the opening in which these louvres are installed must always be 10 mm larger than the louvre dimensions.



ONLINE LOUVRE SELECTOR

How to select the correct louvre for your application?

WEBSITE WWW.RENSON.EU

On the website www.renson.eu you can find an overview of all louvres including technical drawings, leaflets and product summaries. On this website, you can quickly find the most suitable louvre for your application, thanks to the extensive possibilities of searching, filtering, and calculating. You can also download the results of your selection, contact one of our specialists for additional advice, or find a dealer in your area.

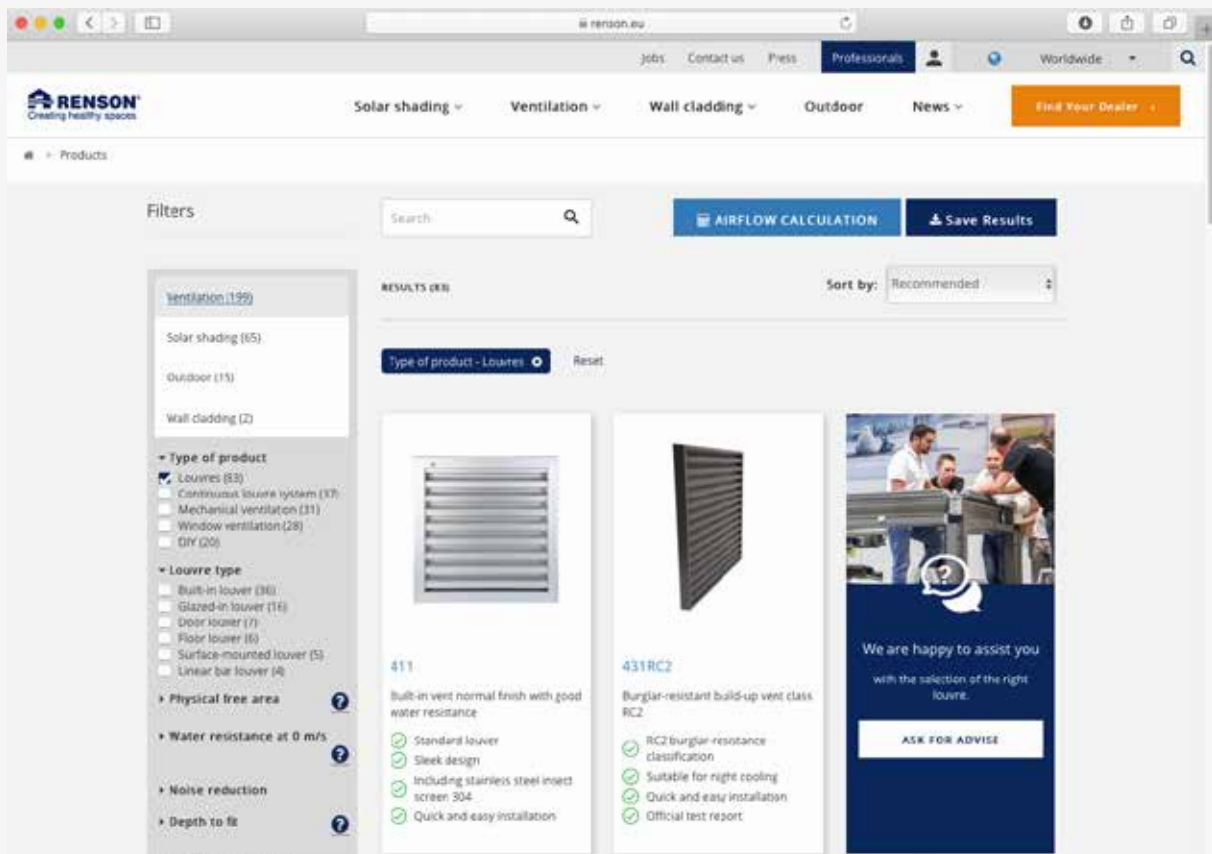

INTENSIVE VENTILATION

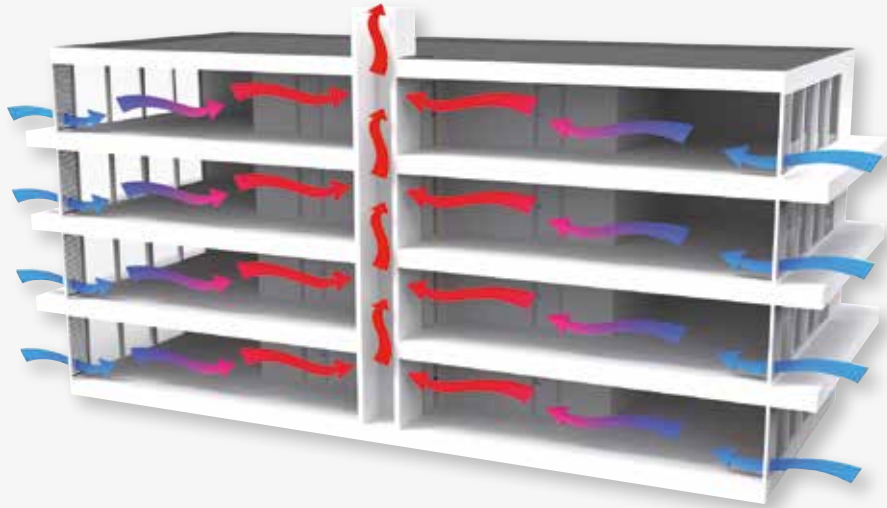

INTENSIVE VENTILATION – NIGHT COOLING

The building will cool down by ventilating with large flows of natural air at night. The indoor climate will remain stable during the day given that the building will warm back up. This can be achieved by using specific louvres. Renson® surface-mounted louvres are recommended for supply, as these can be mounted easily on a [tilt and turn] window. These louvres are available in 3 variants:

- **Type 431**
 - Excellent rain-repellant properties (class A: less than 1% water infiltration at high wind speeds)
 - Maximum airflow (physical free area: 50%)
 - Equipped with stainless steel insect screen
- **Type 432**
 - Same properties as type 431
 - Removable: This louvre can be removed in winter months, when night cooling is not used. In combination with a tilt and turn window with glass insert, this provides extra light in this darker period.
- **Type 431RC2**
 - Same properties as type 431
 - Burglar-resistant class 2: Because the night cooling louvres are typically open when there is little or no surveillance, burglar resistance of the louvres is essential. Class RC2 is the most commonly used burglar resistance class for homes. Only buildings with an increased risk of burglary are often subject to stricter requirements.
 - Fall-proof: Louvres for night cooling are often fitted down to ground level. When this is used on an upper storey, it is important that the louvre offers fall safety.

The same louvres can be used as extraction, preferably in opposite façades. The extraction can also be achieved by air shafts in the building which are finished at the top with a type 440 roof hood.

SELECTION CRITERIA

AIR PERMEABILITY

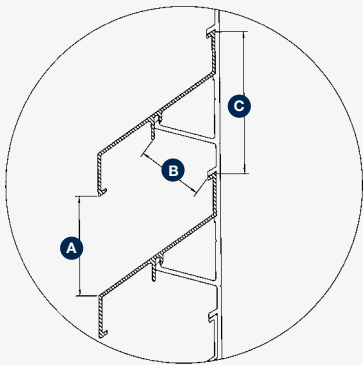

GEOMETRIC TERMS FOR LOUVRES

- **Visual free area** = determined by the ratio of the visual distance between two blades [A] to the blade pitch [C].
- **Physical free area** = determined by the ratio of the smallest gap between two blades [B] to the blade pitch [C]. Owing to peripheral effects and assembly, a maximum deviation of 5% must be considered.
- **Remark: The top and bottom blades are not taken into account in the two free area definitions.**
- All properties of the louvres can be consulted or calculated using the free software on our website.

AIR TECHNICAL TERMS FOR LOUVRES

- **K-factor** = This value describes the ratio between the flow rate through the louvres and the pressure drop across the louvres related to this and depends on the direction of the airflow. The lower the K value, the higher the airflow.
- **C-coefficient** = flow coefficient. This value is a measure of the ease with which air flows through the louvre. The higher the C value, the higher the airflow. The coefficient depends on the direction of the airflow: C_e = air supply, C_d = air extraction. $C = 1 / \sqrt{K}$

NOISE TECHNICAL TERMS / NOISE REDUCTION

- **$R_w [C; C_{tr}]$** = the sound attenuation index of the louvre. This is a measure of the sound attenuation of a louvre, expressed in dB. This value is independent of the dimensions. A louvre of 10 m² lets through 10 dB less noise than a louvre of 1 m² with the same R_w value.
- **$D_{n,e,w}$** = the sound insulation of the louvre. This is a measure of the sound attenuation of a louvre, expressed in dB. This value depends on the dimensions and is mainly used for small building components. A louvre with a $D_{n,e,w}$ value = x dB lets through as much sound as a wall of 10 m² with a R_w value = x dB.
- **C** = spectrum correction for pink noise. This value is usually negative and is added to the R_w or $D_{n,e,w}$ value when mainly the treble has to be muted.
- **C_{tr}** = spectrum correction for traffic noise. This value is usually negative and is added to the R_w or $D_{n,e,w}$ value when mainly the bass has to be muted.
- **dB** = measure of sound intensity.
- **Frequency** = the pitch expressed in Hertz [Hz].

WATERTIGHTNESS TESTS

RAIN-REPELLANT

Renson® louvres are subjected to European testing [according to EN 13030: 2011] by the internationally accredited corporation BSRIA Ltd. During these tests, a louvre of 1m², equipped with stainless steel mesh is exposed to downpours at a rate of 75 litres per hour and a wind speed of 13 m/second. The classification is based on the obtained results, i.e. the quantity of water infiltrating through the louvre.

Attention: The “air speed” reference always indicates the air speed at the suction side. If a louvre is assigned to a watertightness, the class suction side air velocity has to be indicated. The outside wind speed is fixed to 13m/s and is therefore never mentioned.

Remark: In case a weatherable louvre is used in extreme weather conditions Renson® advises to seal the seams of the frame. Additionally, applying a water channel will guarantee an even better weatherability.



WITHOUT WATER CHANNEL

Test on a standard type 411 louvre

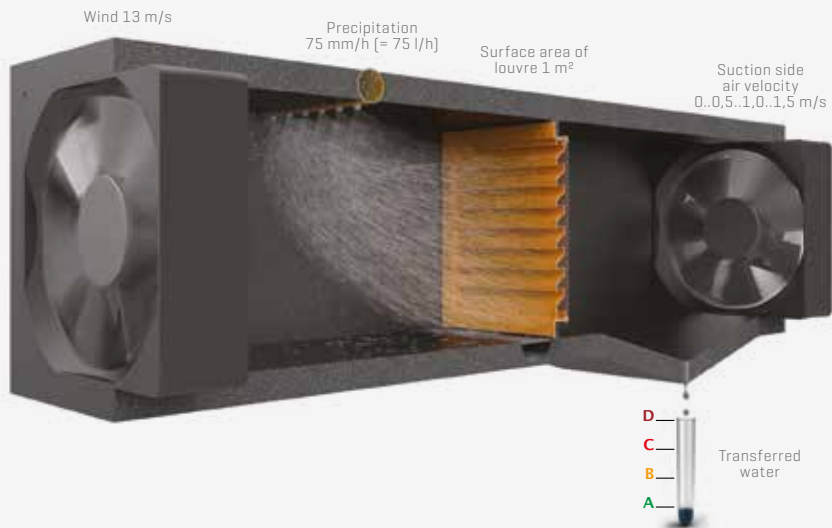

WITH WATER CHANNEL

Test on a type 411 louvre with water channel

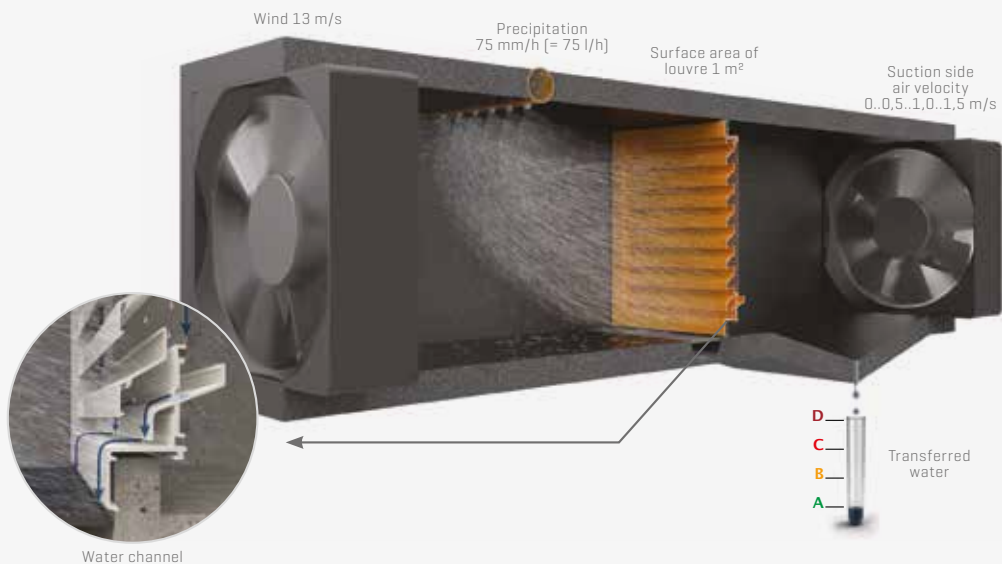

	Class	% watertightness	Air resistance class
Very good rain protection	A	100 - 99 %	$C_e \geq 0,4 : 1$
Good rain protection	B	99,9 - 95 %	$C_e : 0,3 - 0,399 : 2$
Average rain protection	C	94,9 - 80 %	$C_e : 0,2 - 0,299 : 3$
Low rain protection	D	< 80 %	$C_e < 0,2 : 4$

Type of louvre	Insect screen [mm]	Suction air speed [m/s]	With water channel		Without water channel		Suction air resistance Class
			Class	%	Class	%	
450 L.050W	2,3 x 2,3 mm	0,0	A	100			2
		0,5	A	100			
		1,0	A	100			
		1,5	A	100			
		2,0	A	99,9			
		2,5	A	99,9			
		3,0	A	99,2			
<i>Standard equipped with water channel</i>							
450V L.050WV	2,3 x 2,3 mm	0,0	A	100			2
		0,5	A	99,9			
		1,0	A	99,9			
		1,5	A	99,9			
		2,0	A	99,5			
		2,5	A	99,6			
		3,0	A	99,7			
		3,5	A	99,5			
		4,0	A	99,1			
		<i>Standard equipped with water channel</i>					
475/475GL L.075W	2,3 x 2,3 mm	0,0	A	99,2			2
		0,5	B	97,8			
		1,0	B	95,9			
		1,5	C	90,9			
		2,0	D	< 80			
<i>Standard equipped with water channel</i>							
452V L.066VV	2,3 x 2,3 mm	0,0	A	100			4
		0,5	A	100			
		1,0	A	100			
		1,5	A	99,7			
		2,0	C	80,2			
		2,5	D	< 80			
<i>Standard equipped with water channel</i>							
452 L.066V	6 x 6 mm	0,0	A	100			4
		0,5	A	99,9			
		1,0	A	91,6			
		1,5	B	95			
		2,0	D	< 80			
491/494 L.033.08	6 x 6 mm	0,0	A	100			4
		0,5	A	99,7			
		1,0	C	91,6			
		1,5	D	< 80			
		2,0	D	< 80			
422/428 L.033V	6 x 6 mm	0,0	A	99,9	A	99,3	4
		0,5	A	99,5	B	98,1	
		1,0	B	96,9	C	93,4	
		1,5	C	87,9	C	87,5	
		2,0	D	< 80	D	< 80	
		2,5	D	< 80	D	< 80	
411/414/431 L.033.01	2,3 x 2,3 mm	0,0	A	99,5	B	95,3	3
		0,5	A	99,0	C	91,0	
		1,0	B	96,5	C	80,5	
		1,5	D	< 80	D	< 80	
		2,0	D	< 80	D	< 80	
451 L.066.01	6 x 6 mm standard	0,0			B	95,5	3
		0,5			C	92,9	
		1,0			C	90,8	
		1,5			C	82,8	
		2,0			D	< 80	
457	2,3 x 2,3 mm	0,0	B	96,9			3
		0,5	B	95,2			
		1,0	C	93,7			
		1,5	C	89,2			
		2,0	D	< 80			
457	6 x 6 mm	0,0			C	90,4	3
		0,5			C	87,3	
		1,0			C	84,8	
		1,5			C	81,3	
		2,0			D	< 80	
		2,5			D	< 80	
421/424 L.050.00	2,3 x 2,3 mm standard	0,0	B	95	C	90,6	3
		0,5	C	92,2	C	87,7	
		1,0	C	89,8			
		1,5	C	84,5			
		2,0	D	< 80			
		2,5	D	< 80			
481/484	2,3 x 2,3 mm	0,0	B	96			2
		0,5	C	94,3			
		1,0	C	92,2			
		1,5	C	88,2			
		2,0	D	< 80			
412/415	2,3 x 2,3 mm	0,0	A	99,9			4
		0,5	A	99,7			
		1,0	A	99,2			
		1,5	B	95,6			
		2	C	87,5			
		2,5	D	< 80			
412/415	6 x 6 mm standard	0,0			C	90,4	4
		0,5			D	81,6	
		1,0			D	< 80	
446/150 L.150AC	2,3 x 2,3 mm	0,0	A	99,3			4
		0,5	B	96,6			
		1,0	C	91,3			
		1,5	D	< 80			
480/483 L.060HF	2,3 x 2,3 mm	0,0	C	90,1	D	< 80	1
		0,5	C	87,3			
		1,0	C	84,2			
		1,5	C	80,1			
		2,0	D	< 80			
445/86 L.060AC	-	0,0			C	83,3	2
		0,5			D	< 80	

SELECTION CRITERIA

IP-CLASSES

- **IP-class** = international protection rating, protection level against the intrusion of strange objects and water. The IP-class has two figures: the first one indicates the level of protection against physical contact and the intrusion of strange objects; the second is the level of protection against moisture. Additionally, a letter can indicate which protection is offered against physical contact with hazardous objects by people within the housing [electrical enclosures]. The distance to the electrical installation is measured from the outer surface area of the louvres. The IP-class of the louvres is determined in accordance with EN 60529.
- **Meaning IP2XD:**
 - 2: Protection against medium-sized objects/approach by fingers. Protection against the intrusion of medium-sized objects [larger than 12.5 mm].
 - X: Protection against moisture is not verified according to this standard given that the louvres are tested according to the more accurate water-resistance test for louvres according to EN 13030.
 - D: Protection against contact with wire (Ø 1 mm, length 100 mm)
- **Meaning IP44:**
 - 4: Protection against sharp objects/contact with a tool/wire.
 - Protection against the intrusion of fixed objects larger than 1 mm
 - 4: Splash-proof: protected from water spray from any direction [10 l/min].

TEST REPORTS

Louvres that comply with specific requirements are tested by independent institutions according to specific EN standards. Test reports for air permeability, IP rating, burglar resistance, sound reduction, and water-repellant properties are available on our website or upon request.



Burglar resistance: louvre tested according to official RC classification



Waterproof: louvre with high classification [see p. 12]



Acoustic damping: louvre equipped with acoustic mineral wool for noise reduction



Stick-proof: this louvre has been IP certified [EN 60529]

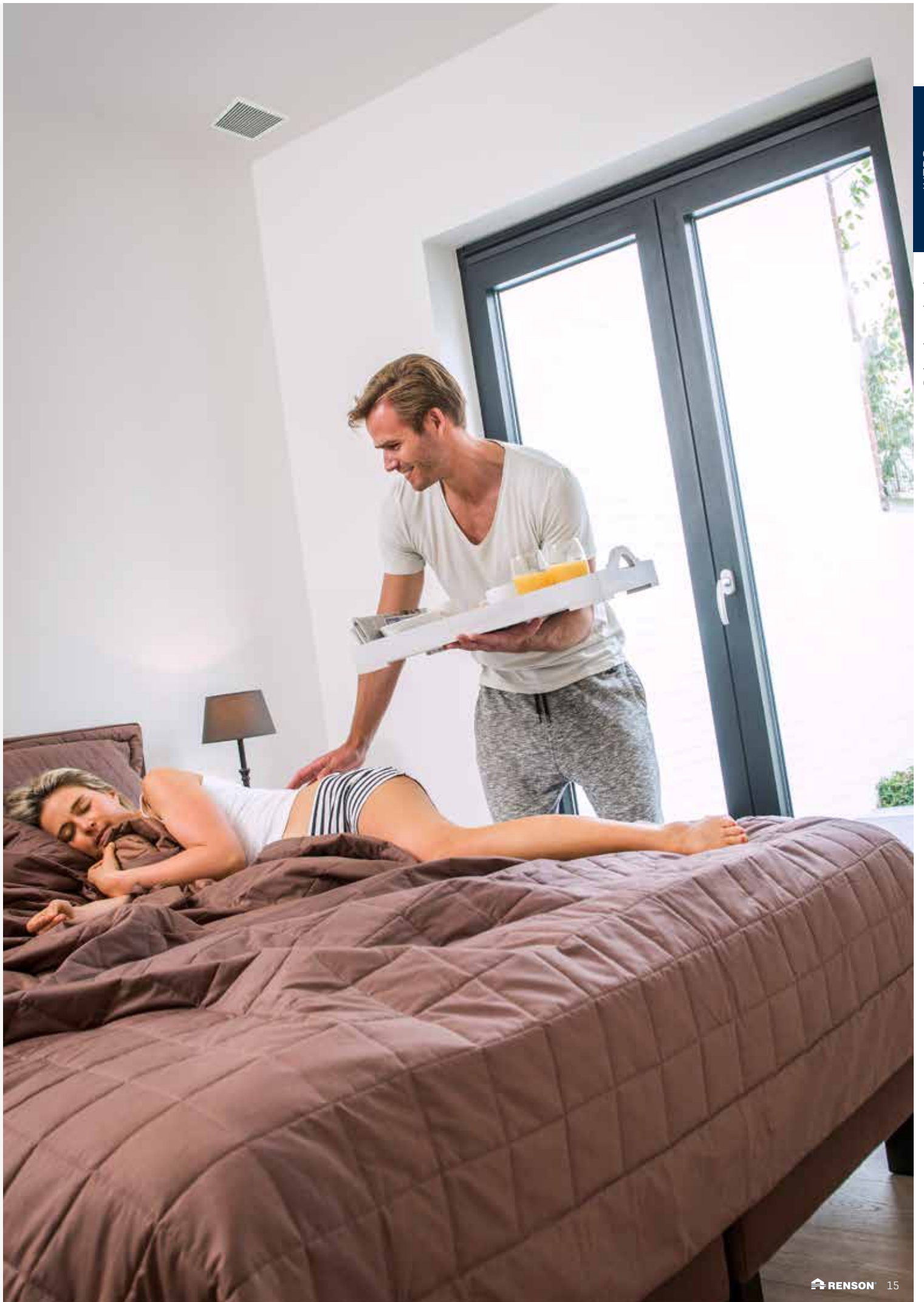

OPTIONS

DRAINAGE BLADE

This option is available for most types of rectangular aluminium louvres.

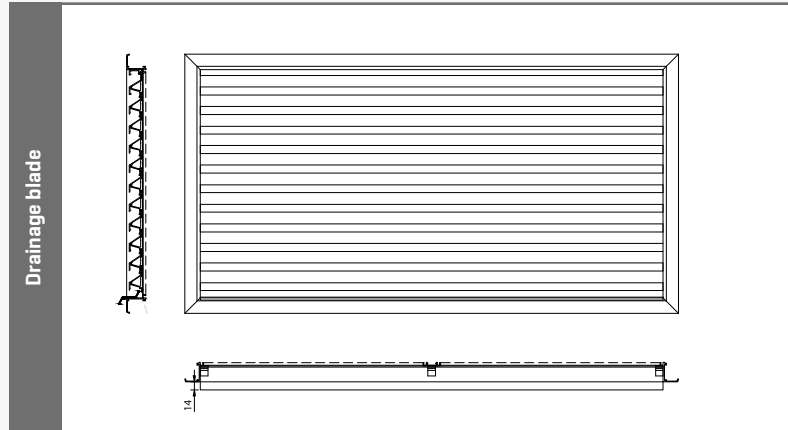

CONNECTED LOUVRES

If the desired louvre dimensions are larger than the maximum dimensions, many louvre types can be supplied in sections that can be connected on site. Possibilities and limitations are analysed on a project basis.

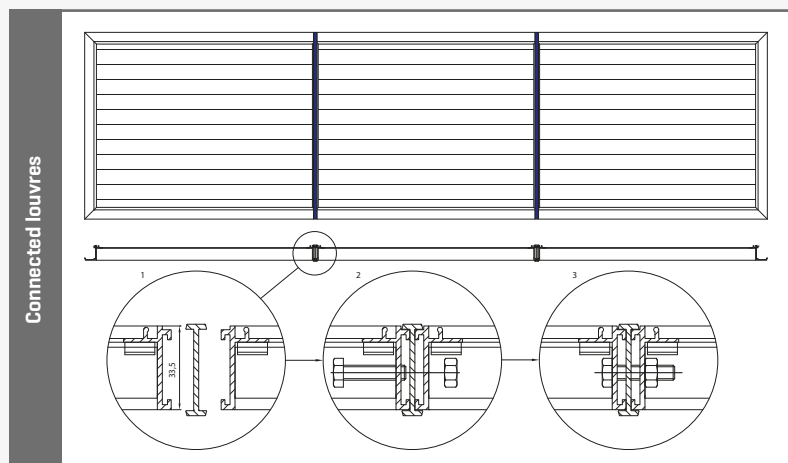

WATER CHANNEL

A water channel can be used with a large number of louvre types with straight bottom sides.

This option always has to be combined with a 2.3 x 2.3 mm insect screen.

The water channel ensures better drainage of the water collected by the screen and thus increases the water-repellant characteristics of the louvre.

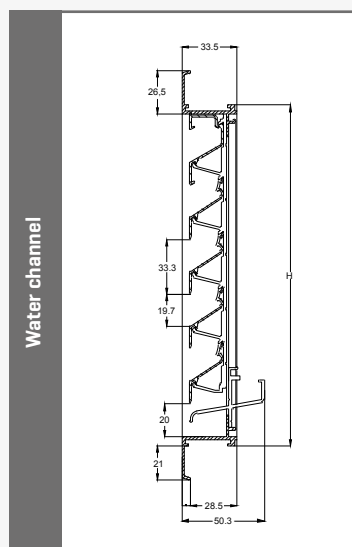

DUST FILTER

The louvre is extended with an additional frame with dust filter.
 The additional louvre depth is 21 mm.
 The applied filter is a class G4: This type of filter is commonly used in ventilation systems and filters dust particles from $\pm 5 \mu\text{m}$ (0.005 mm).
 G4 filters filter more than 90% of these dust particles from the air, making them the best category of their kind.

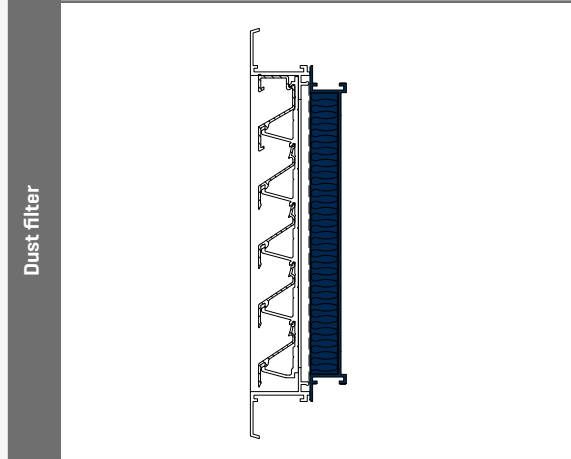

REMOVABLE INSECT MESH 401

Material

- Pick-up angle (non-visible) in polyamide
- Mesh in stainless steel 304/6x6 mm/2.3x2.3 mm

Dimensions

- Minimum dimensions: 190 x 190 mm
- Maximum dimensions: 1500 x 1500 mm
- If width or height > 1500 mm : removable mesh in 2 or more pieces – width and height > 1500 mm is not possible.

Advantages

- Integrated water channel
- Aesthetical mesh
- No technical details visible
- Applicable to louvres with water channel



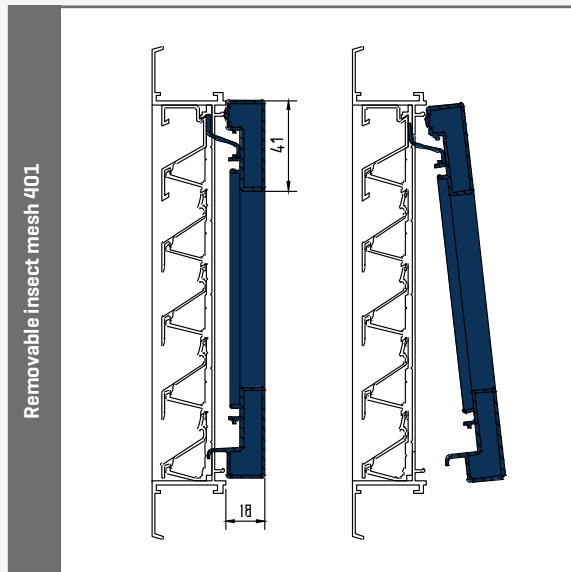











Remark: not applicable to surface-mounted louvres



OVERVIEW OF THE RANGE

Blade type	Family					Airflow				Page
	Louvre type	Product type	Blade pitch [mm]	Physical free area [%]	K-factor supply	K-factor discharge	C _s coefficient	C _d coefficient		
V20 blade	Built-in wall louvre	  412	20	39	34.6	34.6	0.170	0.170	28	
V20 blade	Built-in wall louvre	  412R	20	39	34.6	34.6	0.170	0.170	30	
V20 blade	Glazed-in louvre	  415	20	39	34.6	34.6	0.170	0.170	88	
V20 blade	Controllable glazed-in louvres	  415VA	20	n/a	n/a	n/a	n/a	n/a	92	
V20 blade	Round glazed-in louvre	  415R	20	39	34.6	34.6	0.170	0.170	90	
L.033.01	Built-in wall louvre	 411	33.3	50	20.47	19.58	0.221	0.226	22	
L.033.07	Built-in wall louvre	411R	33.3	40.5	23.56	25.51	0.206	0.198	26	
L.033.01	Glazed-in louvre	 414	33.3	50	20.47	19.58	0.221	0.226	80	
L.033.07	Round glazed-in louvre	414R	33.3	40.5	23.56	25.51	0.206	0.198	82	
L.033.01	Glazed-in louvre	414/D	33.3	n/a	n/a	n/a	n/a	n/a	84	
L.033.01	Controllable glazed-in louvres	414/VA	33.3	n/a	n/a	n/a	n/a	n/a	84	
L.033.01	Glazed-in louvre Thermally broken frame	414THF	33.3	50	20.47	19.58	0.221	0.226	86	
L.033.01	Surface-mounted louvre	 431	33.3	50	20.47	19.58	0.221	0.226	72	
L.033.07	Surface-mounted louvre	431R	33.3	40.5	23.56	25.51	0.206	0.198	74	
L.033.01	Surface-mounted louvre	432	33.3	50	20.47	19.58	0.221	0.226	76	
L.033.01	Louvre box	440/11	33.3	50	20.47	19.58	0.221	0.226	128	
L.033.08	Built-in wall louvre	  491	33.3	26	123.5	118.1	0.09	0.092	70	
L.033.08	Glazed-in louvre	  494	33.3	26	123.5	118.1	0.09	0.092	102	
L.033V	Built-in wall louvre	422	33.3	43	66.10	66.10	0.123	0.123	36	
L.033V	Glazed-in louvre	 428	33.3	43	66.10	66.10	0.123	0.123	96	
L.050.00	Built-in wall louvre	421	50	49	13.42	11.73	0.273	0.292	32	
L.050.00	Round built-in wall louvre	421R	50	47	13.42	11.73	0.273	0.292	34	
L.050.00	Louvre box	440/21	50	49	13.42	11.73	0.273	0.292	128	
L.050.00	Glazed-in louvre	424	50	49	13.42	11.73	0.273	0.292	94	
L.050HF	Built-in wall louvre	481	50	60	9.59	10.01	0.323	0.316	50	
L.050HF	Glazed-in louvre	484	50	60	9.59	10.01	0.323	0.316	100	
L.050W	Built-in wall louvre	 450	50	57	10.47	16.52	0.309	0.246	58	
L.050W	Built-in wall louvre	 76 450V	50	57	10.75	16.52	0.305	0.246	60	
L.060HF	Built-in wall louvre	480	60	76	5.12	5.59	0.442	0.423	48	
L.060HF	Glazed-in louvre	 76 483	60	76	5.12	5.59	0.442	0.423	98	
L.066.01	Built-in wall louvre	451	66	49	14.24	11.77	0.265	0.291	40	
L.066V	Built-in wall louvre	  452	66	41	66.1	79.7	0.123	0.112	62	
L.066V	Built-in wall louvre	  452V	66	41	60.1	79.9	0.129	0.114	64	
L.065AL	Built-in wall louvre	453	65	55	13.92	17.22	0.268	0.241	42	
L.075HF	Built-in wall louvre	457	75	52	13.13	14.24	0.276	0.265	46	
Vertical blade	Built-in wall louvre	  97 468SA	85	29	115.62	115.62	0.093	0.093	46	
L.075W	Built-in wall louvre	 475	75	53	10.89	10.41	0.303	0.310	66	
L.075W	Glazed-in louvre	 475GL	75	53	10.89	10.41	0.303	0.310	68	

Remark: test results according to louvres including mesh.

Family					Airflow				Page
Blade type	Louvre type	Product type	Blade pitch [mm]	Physical free area [%]	K-factor supply	K-factor discharge	C _e coefficient	C _d coefficient	
Movable blade	Built-in wall louvre	427	100	53	11.41	11.65	0.296	0.293	38
Movable blade	Glazed-in louvre	427GL	100	53	11.41	11.65	0.296	0.293	104
L.060AC	Acoustic louvre	 445/86	60	34	10,75	9,95	0,305	0,317	106
L.150ACS.01	Acoustic louvre	 446/150	150	34.3	38.46	34.48	0.161	0.169	108
L.150ACL.01	Acoustic louvre	 446/225	150	34.3	37.3	41.9	0.164	0.15	110
L.150ACS.01	Acoustic louvre	 446/300	150	34.3	45.93	45.93	0.148	0.148	112
L.150ACS.01	Acoustic louvre	 447/150	170	37	25.46	25.15	0.198	0.200	114
L.150ACL.01	Acoustic louvre	 447/225	170	37	28.58	30.88	0.187	0.180	116
Acoustic	Acoustic louvre	 468AK	85	29	86.85	89.35	0.107	0.106	140
Glass blade	Glazed-in louvre	327	n/a	n/a	n/a	n/a	n/a	n/a	110
Floor blade	Floor grille	311	16.5	76	n/a	n/a	n/a	n/a	130
Floor blade	Floor grille	371	20.5	61	n/a	n/a	n/a	n/a	132
Strips	Ventilation grille	381	n/a	80	n/a	n/a	n/a	n/a	172
Linear blade	Linear bar grille	392	13	76	n/a	n/a	n/a	n/a	134
Linear blade	Linear bar grille	394	16.5	59	n/a	n/a	n/a	n/a	136
Punched	Punched grille	435R	n/a	n/a	n/a	n/a	n/a	n/a	166
Sliding blade	Controllable internal louvre	4032	n/a	n/a	n/a	n/a	n/a	n/a	158
Sliding blade	Controllable internal louvre	441	n/a	n/a	n/a	n/a	n/a	n/a	157
Sliding blade	Controllable internal louvre	442	n/a	n/a	n/a	n/a	n/a	n/a	156
Door blade	Door grille	 461	20	39	33.8	33.8	0.172	0.172	138
Extractor	Surface-mounted louvre	433	37 or 99	n/a	n/a	n/a	n/a	n/a	78
Door blade	Door grille	 469 Invisido	n/a	n/a	17.03	17.03	0.24	0.24	146
Door blade	Door grille	 461AK Silendo	n/a	27	6.13	6.13	0.40	0.40	144
Burglar resistance blade	Burglar resistance louvre	 421RC2	50	43	13.82	12.85	0.269	0.279	118
Burglar resistance blade	Burglar resistance louvre	 421RC3	50	43	13.82	12.85	0.269	0.279	124
Burglar resistance blade	Burglar resistance louvre	 424RC2	50	43	13.82	12.85	0.269	0.279	120
L.033.07	Burglar resistance louvre	 431RC2	33.3	40.5	23.56	25.51	0.206	0.198	122
Burglar resistance blade	Burglar resistance louvre	 423RC4	50	22	27.06	27.28	0.193	0.192	126
Fire blade	Fire-resistant louvre	464 Incendo	20	51	10.27	10.27	0.312	0.312	148
Fire blade	Fire-resistant louvre	465	17.5	57	8.16	8.16	0.350	0.350	150
Fire blade	Fire-resistant louvre	466	20	70	6.80	6.80	0.383	0.383	152
Fire blade	Fire-resistant louvre	467	18	66.7	4.16	4.06	0.490	0.496	154
Galvanised blade	Built-in wall louvre	511	33.3	43	92.13	84.73	0.104	0.109	52
Galvanised blade	Built-in wall louvre	521	50	54	14.91	16.00	0.259	0.250	54
Stainless blade	Built-in wall louvre	621	50	54	14.91	16.00	0.259	0.250	56

PRODUCTS



414 - Glazed-in louvre



421 - Wall louvre, heavy-duty series



411 - Wall louvre



411

Wall louvre, standard series

BUILT-IN WALL
LOUVRE

ALUMINIUM



411 with thermal insulation panel



Cable feed channel

MATERIAL

- Made from aluminium sections: AlMgSi 0.5 [according to EN 12020-2]
- Stainless steel 304 insect screen [2.3 x 2.3 mm]
- Finishing: anodized in satin colour [20 micron] or powder-coated in any RAL or Syntha Pulvin colour [40 micron]

DIMENSIONS

- Blade pitch: 33,3 mm
- Depth to fit: 29 mm
- Flange size: 21 mm
- Minimum dimensions: 100 x 100 mm

FIXING

- Brackets ref. 418
- Spring clips ref. 419 available on request [small dimensions]
- For louvres larger than approx. 3 m², a reinforcing mullion is required to suit span and windload

OPTIONS *[see p. 16]*

- Water channel
- Drainage profile
- Removable insect mesh
- Backframe
- Filter
- Special shape *[see next p.]*
- Controllable *[see next p.]*
- Without flange *[see next p.]*
- Glazed-in louvre 414 *[see p. 80]*
- Stainless steel 304 mesh [6x6/10x10/20x20 mm] or without
- Insect screen or mesh in stainless steel 316
- Spring clips 419 [small dimensions]
- Cable feed channel

TYPICAL APPLICATIONS

- Every application without specific needs



TECHNICAL SPECIFICATIONS

All properties are valid for the standard version of the Louvre, unless otherwise stated.

Weatherability	[EN 13030]
Class [details see p. 12]	A3 [0.5 m/s]
Airflow	[EN 13030]
K-factor [entry]	20.47
K-factor [discharge]	19.58
C _e coefficient	0.221
C _d coefficient	0.226
Technical data	
Visual free area	59%
Physical free area	50%
IP class [louvre with mesh; electrical installation at least 100 mm from louvre]	IP2XD



TECHNICAL DRAWINGS

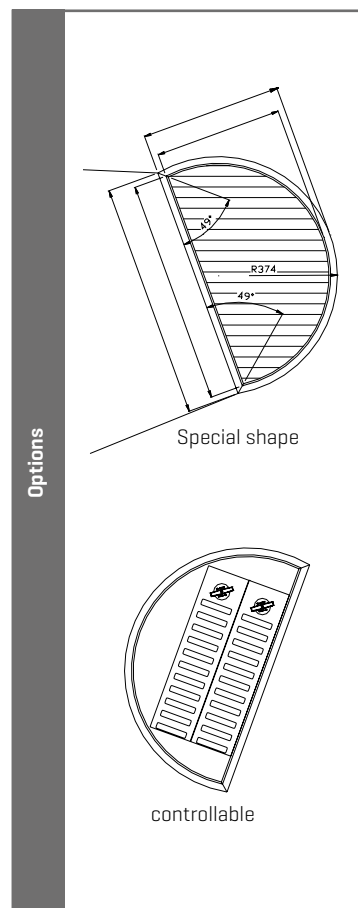
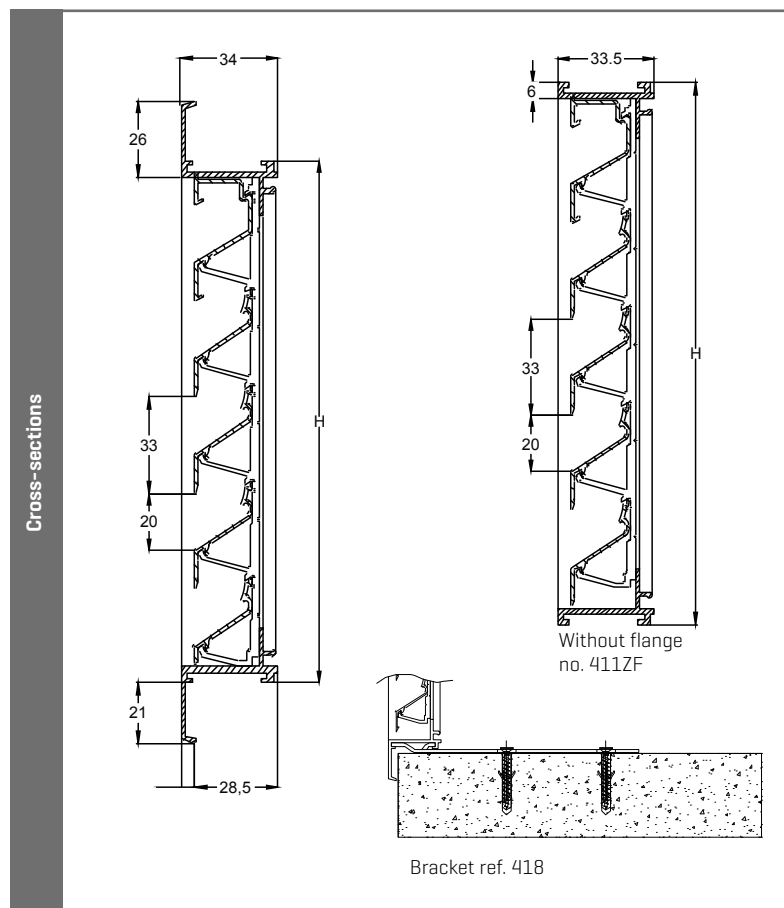

411

Wall louvre, standard series

BUILT-IN WALL
LOUVRE



ALUMINIUM



STOCK MODELS

Dimensions (W x H) mm	Natural colour anodised F1	Renson Standard WHITE	STR 7016	STR 9005	Airflow at 2 Pa (m ³ /h)
142 x 142	00041197				23
200 x 200	00041122	00411226	00411223	00411229	50
300 x 200	00041132				77
300 x 300	00041133				118
400 x 200	00041142	00411426			103
400 x 300	00041143	00411436			159
400 x 400	00041144	00411446			215
500 x 300	00041153				201
500 x 400	00041154				271
500 x 500	00041155				342
600 x 300	00041163				242
600 x 400	00041164				327
600 x 600	00041166				497
700 x 700	00041177				682
1000 x 500	00411105				694
1000 x 1000	00041111				1409

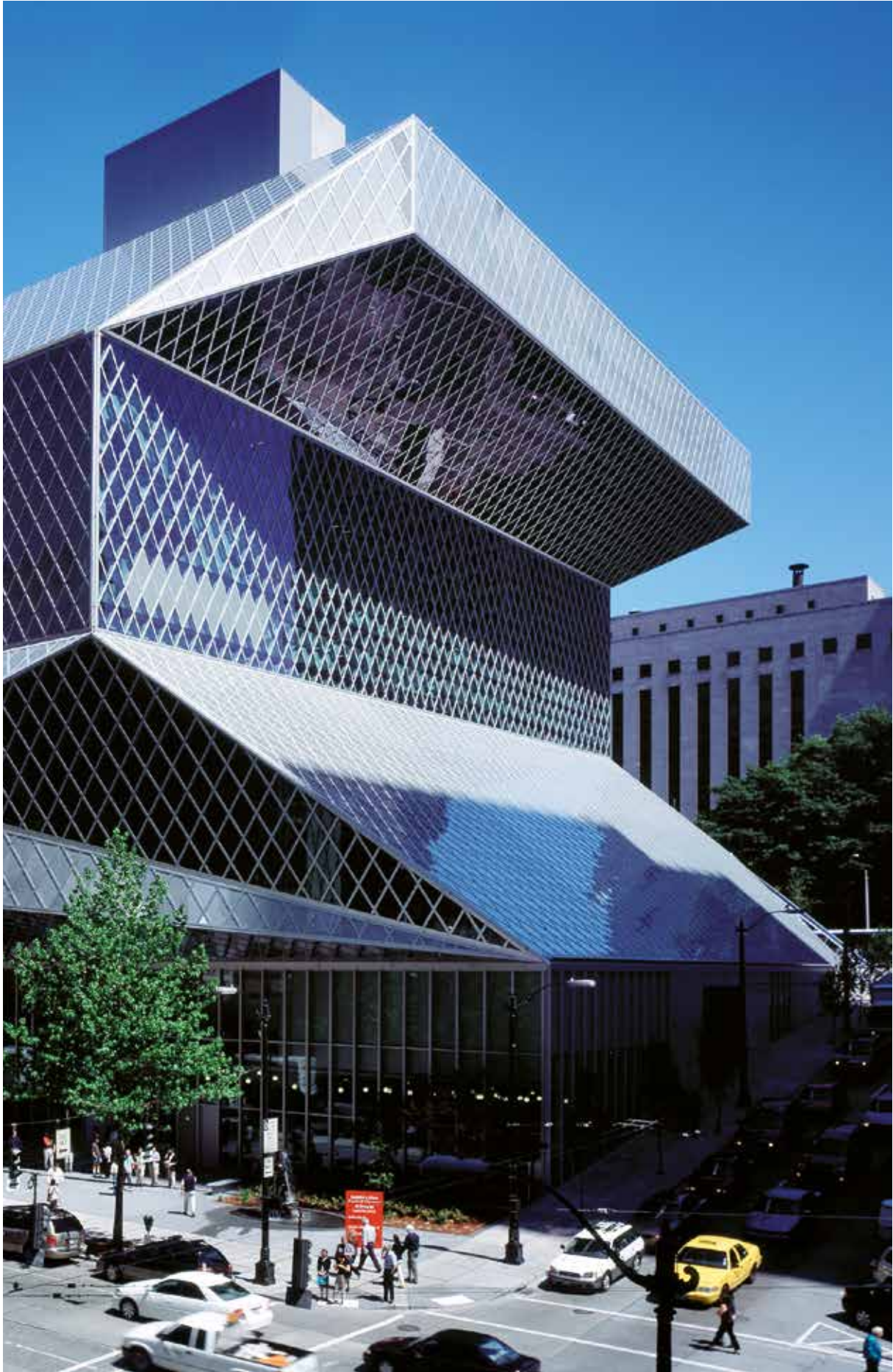

411R

Round wall louvre

BUILT-IN WALL
LOUVRE

ALUMINIUM

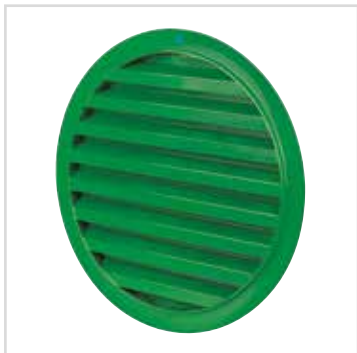

MATERIAL

- Made from aluminium sections: AlMgSi 0.5 [according to EN 12020-2]
- Stainless steel 304 insect screen [2.3 x 2.3 mm]
- Finishing: anodized in satin colour [20 micron] or powder-coated in any RAL or Syntha Pulvin colour [40 micron]
- Frame assembled by a single weld

DIMENSIONS

- Blade pitch: 33,3 mm
- Depth to fit: 28 mm
- Flange size: 23 mm
- Minimum diameter: 300 mm
- Maximum diameter:
 - 1400 mm if anodised in satin colour
 - 1500 mm if powder-coated in RAL or Syntha Pulvin colour
 - Over 1500 mm: in two parts

FIXING

- Brackets pre-fitted to the frame

OPTION

- Glazed-in louvre 414R [see p. 82]
- Stainless steel 304 mesh [6x6/10x10/20x20 mm] or without
- Insect screen or mesh in stainless steel 316
- Without flange

TYPICAL APPLICATIONS

- Every application without specific needs

STOCK MODELS

Available until end of stock – after that, only available as custom product.

Dimensions (W x H) mm	Natural colour anodised F1	Airflow at 2 Pa (m ³ /h)
ø 300	41103001	96

TECHNICAL SPECIFICATIONS

All properties are valid for the standard version of the Louvre, unless otherwise stated.

Airflow		[EN 13030]
K-factor [entry]		23.56
K-factor [discharge]		25.51
C _e coefficient		0.206
C _d coefficient		0.198
Technical data		
Visual free area		59%
Physical free area		40.5%
IP class [louvre with mesh; electrical installation at least 100 mm from louvre]		IP2XD



TECHNICAL DRAWINGS

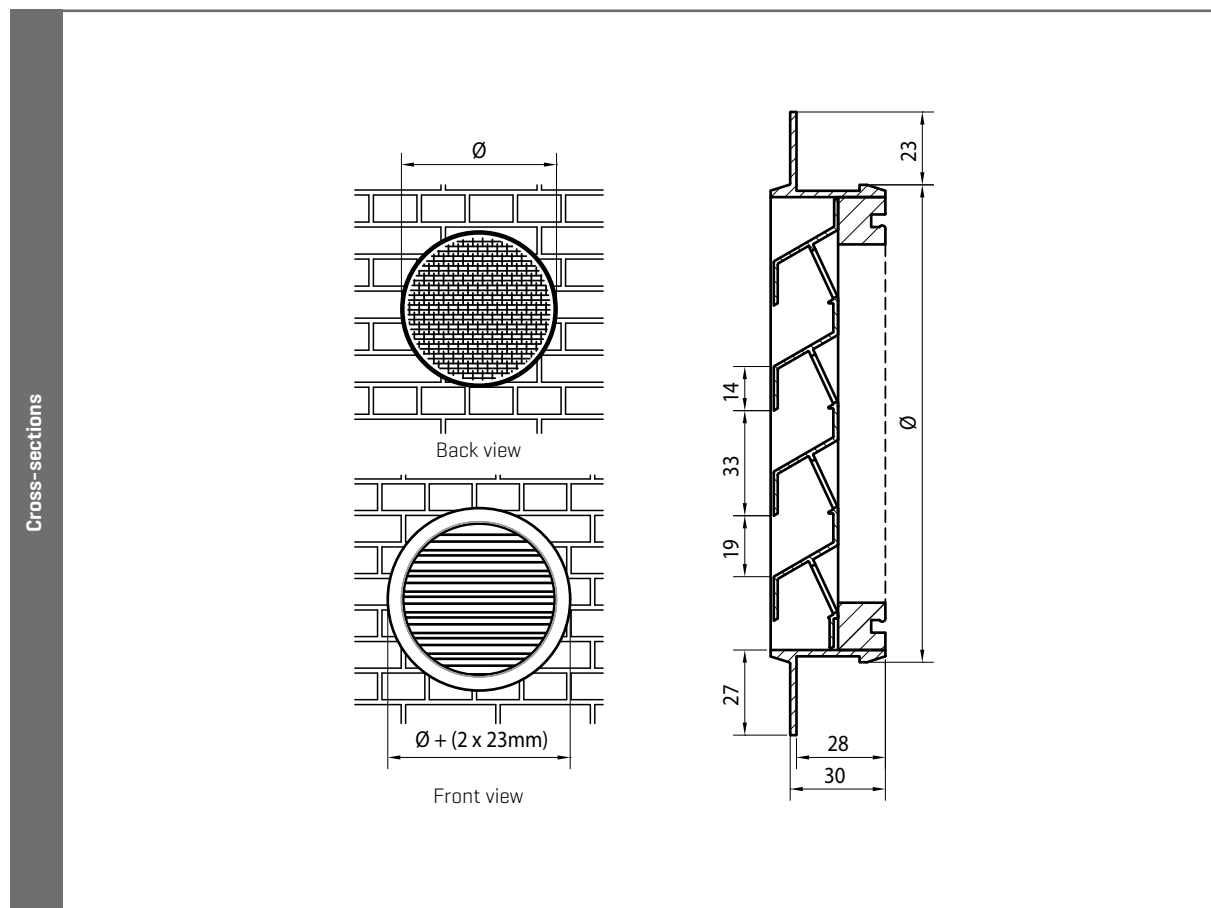

412

Built-in wall louvre with chevron section blades

BUILT-IN WALL
LOUVRE

ALUMINIUM



412 with dust filter

MATERIAL

- Made from aluminium sections: AlMgSi 0.5 (according to EN 12020-2)
- Stainless steel 304 mesh [6 x 6 mm]
- Finishing: anodized in satin colour [20 micron] or powder-coated in any RAL or Syntha Pulvin colour [40 micron]
- Equipped with earthing lug

DIMENSIONS

- Blade pitch: 20 mm chevron
- Depth to fit: 29 mm
- Flange size: 21 mm
- Minimum dimensions: 100 x 100 mm

FIXING

- Brackets ref. 418
- For louvres larger than approx. 3 m², a reinforcing mullion is required to suit span and windload

OPTIONS

- Water channel
- Drainage profile
- Removable insect mesh
- Backframe
- Filter
- Without flange
- Glazed-in louvre 415 (see p. 88)
- Stainless steel 304 mesh [2,3x2,3/10x10/20x20 mm] or without
- Insect screen or mesh in stainless steel 316
- Spring clips 419 (small dimensions)

TYPICAL APPLICATIONS

- High-voltage stations
- IT rooms

STOCK MODELS

Dimensions (W x H) mm	Natural colour anodised F1	Airflow at 2 Pa (m ³ /h)
200 x 200	00041222	45
300 x 300	00041233	102
400 x 300	00041243	136
500 x 300	00041253	170
600 x 400	00041264	271



TECHNICAL SPECIFICATIONS

All properties are valid for the standard version of the Louvre, unless otherwise stated.

Weatherability		[EN 13030]
Class for execution with mesh 2.3x2.3 mm and water channel (details see p. 12)		A4 [1 m/s]
Airflow		[EN 13030]
K-factor [entry]		34.60
K-factor [discharge]		34.60
C _e coefficient		0.170
C _d coefficient		0.170
Technical data		
Visual free area		93%
Physical free area		39%
IP class		IP2XD
IP class for version with mesh 2.3x2.3 mm and water channel (electrical installation at least 350 mm)		IP44



TECHNICAL DRAWINGS

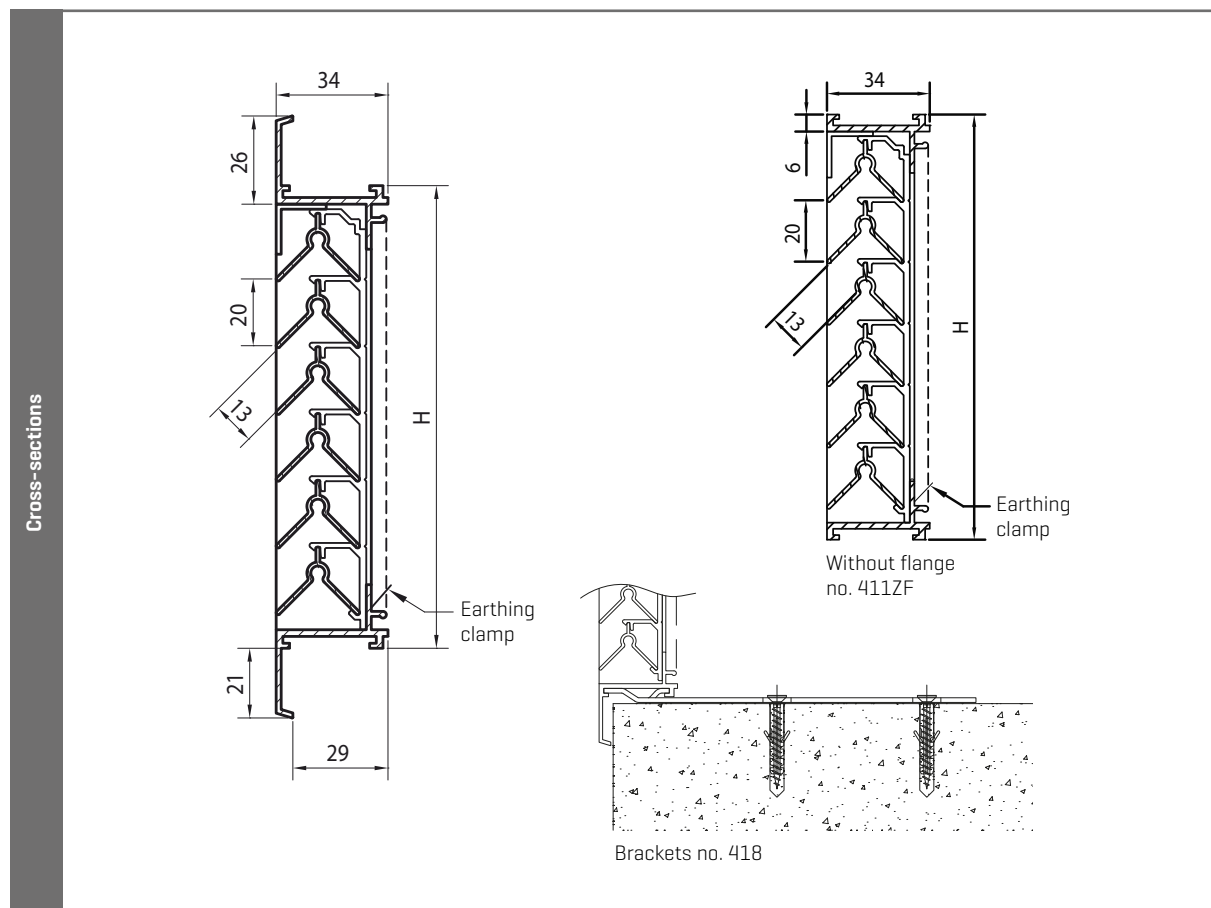

412R

Round wall louvre with chevron section blades

BUILT-IN WALL
LOUVRE

ALUMINIUM



MATERIAL

- Made from aluminium sections: AlMgSi 0.5 [according to EN 12020-2]
- Stainless steel 304 mesh [6 x 6 mm]
- Finishing: anodized in satin colour [20 micron] or powder-coated in any RAL or Syntha Pulvin colour [40 micron]
- Frame assembled by a single weld

DIMENSIONS

- Blade pitch: 20 mm chevron
- Depth to fit: 34 mm
- Flange size: 23 mm
- Minimum diameter: 300 mm
- Maximum diameter:
 - 1400 mm if anodised in satin colour
 - 1500 mm if powder-coated in RAL or Syntha Pulvin colour
 - Over 1500 mm: in two parts

FIXING

- Brackets pre-fit to the frame

OPTIONS

- Glazed-in louvre 415R [see p. 90]
- Stainless steel 304 mesh [2,3x2,3/10x10/20x20 mm] or without
- Insect screen or mesh in stainless steel 316

TYPICAL APPLICATIONS

- High-voltage stations
- IT rooms



TECHNICAL SPECIFICATIONS

All properties are valid for the standard version of the Louvre, unless otherwise stated.

Airflow		[EN 13030]
K-factor [entry]		34.60
K-factor [discharge]		34.60
C _e coefficient		0.170
C _d coefficient		0.170
Technical data		
Visual free area		93%
Physical free area		39%
IP class		IP2XD

TECHNICAL DRAWINGS

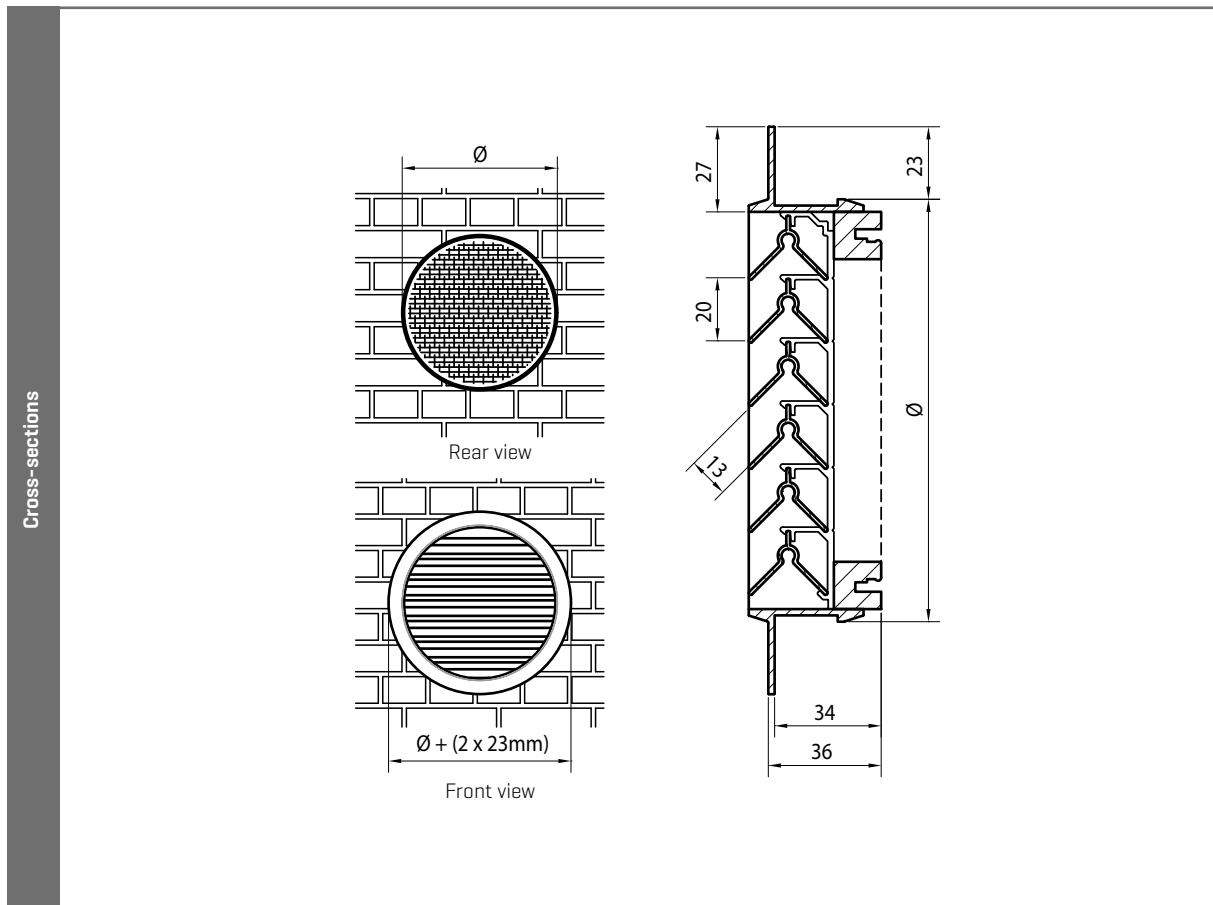

421

Built-in wall louvre, heavy-duty series

BUILT-IN WALL
LOUVRE

ALUMINIUM



MATERIAL

- Made from aluminium sections: AlMgSi 0.5 [according to EN 12020-2]
- Stainless steel 304 insect screen [2.3 x 2.3 mm]
- Finishing: anodized in satin colour [20 micron] or powder-coated in any RAL or Syntha Pulvin colour [40 micron]

DIMENSIONS

- Blade pitch: 50 mm
- Depth to fit: 46 mm
- Flange size: 40 mm
- Minimum dimensions: 150 x 150 mm

FIXING

- Brackets ref. 1428
- For louvres larger than approx. 3 m², a reinforcing mullion is required to suit span and windload

OPTIONS

- Water channel
- Drainage profile
- Removable insect mesh
- Filter
- Without flange
- Glazed-in louvre 424 [see p. 94]
- Burglar resistance louvre 421RC2 [see p. 118]
- Stainless steel 304 mesh [6x6/10x10/20x20 mm] or without
- Insect screen or mesh in stainless steel 316

TYPICAL APPLICATIONS

- Applications where aesthetics and strength are key parameters

TECHNICAL SPECIFICATIONS

All properties are valid for the standard version of the Louvre, unless otherwise stated.

Airflow		[EN 13030]
K-factor [entry]		13.42
K-factor [discharge]		11.73
C _e coefficient		0.273
C _d coefficient		0.292
Technical data		
Visual free area		70%
Physical free area		49%
IP class [louvre with mesh; electrical installation at least 100 mm from louvre]		IP2XD



TECHNICAL DRAWINGS

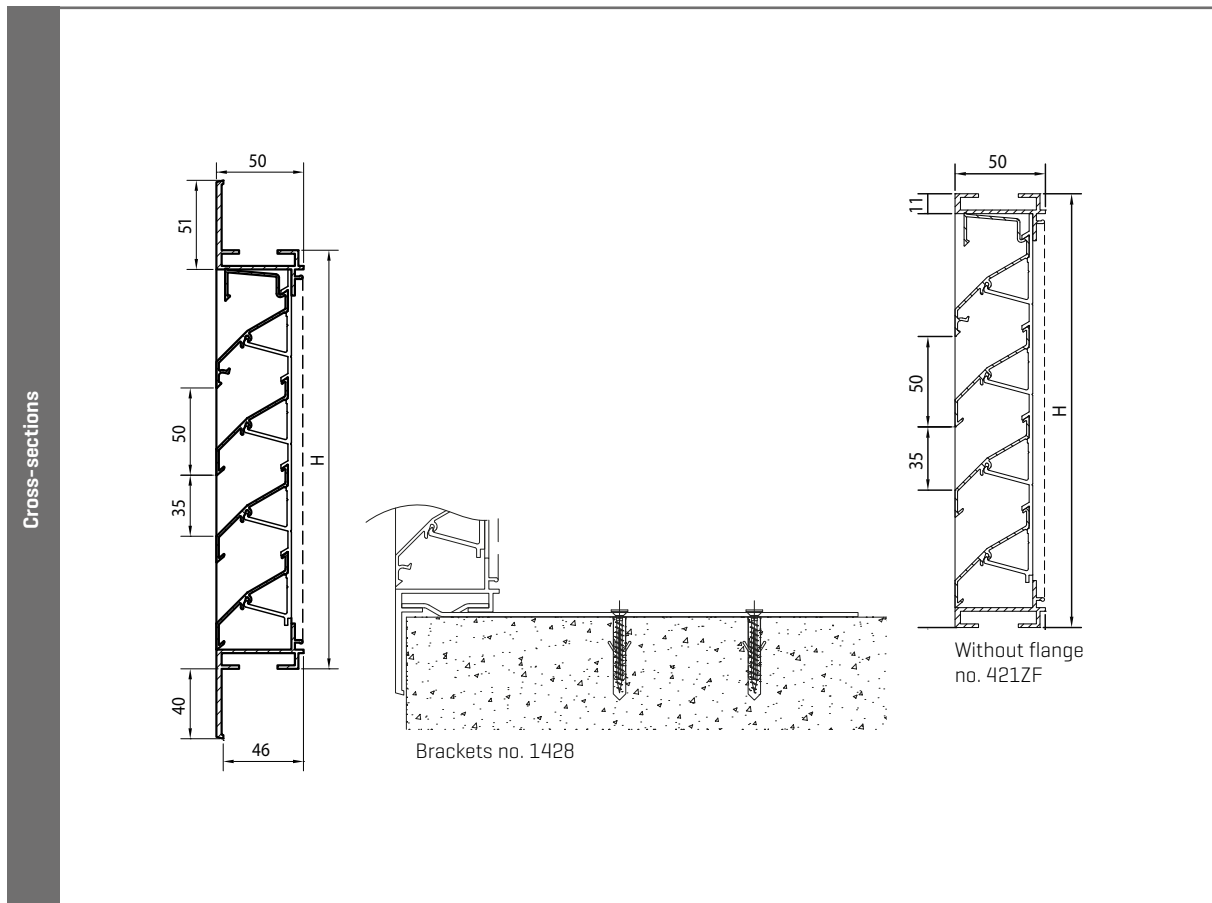

421R

Round wall louvre, heavy-duty series

BUILT-IN WALL
LOUVRE

ALUMINIUM



MATERIAL

- Made from aluminium sections: AlMgSi 0.5 [according to EN 12020-2]
- Finishing: anodised in satin colour (20 microns) or powder-coated in any RAL or Syntha Pulvin colour (40 microns)
- Stainless steel 304 insect screen (2.3 x 2.3 mm)
- Frame assembled by a single weld

DIMENSIONS

- Blade pitch: 50 mm
- Depth to fit: 57 mm
- Flange size: 22 mm
- Minimum diameter: 400 mm
- Maximum diameter:
 - 1400 mm if anodised in satin colour
 - 1500 mm if powder-coated in RAL or Syntha Pulvin colour
 - Over 1500 mm: in two parts

FIXING

- Brackets pre-fit to the frame

TYPICAL APPLICATIONS

- Applications where aesthetics and strength are key parameters

TECHNICAL SPECIFICATIONS

All properties are valid for the standard version of the Louvre, unless otherwise stated.

Airflow		[EN 13030]
K-factor [entry]		13.42
K-factor [discharge]		11.73
C _e coefficient		0.273
C _d coefficient		0.292
Technical data		
Visual free area		70%
Physical free area		47%
IP class [louvre with mesh; electrical installation at least 100 mm from louvre]		IP2XD



TECHNICAL DRAWINGS

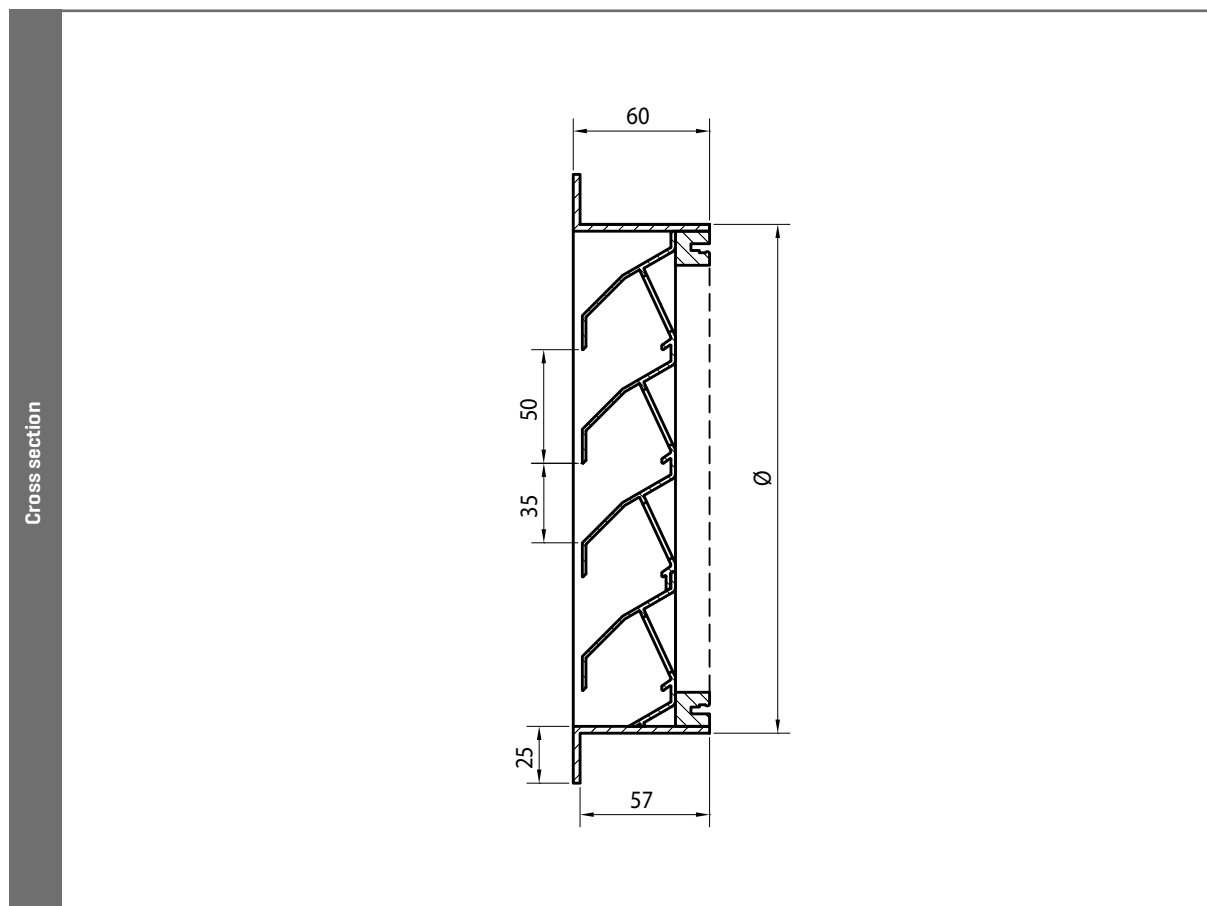

422

AVAILABLE UNTIL END OF STOCK

Built-in wall louvre with chevron section blades, heavy-duty series

BUILT-IN WALL
LOUVRE

ALUMINIUM



MATERIAL

- Made from aluminium sections: AlMgSi 0.5 [according to EN 12020-2]
- Standard stainless steel 304 insect screen [6 x 6 mm]
- Finishing: anodized in satin colour [20 micron] or powder-coated in any RAL or Syntha Pulvin colour [40 micron]

DIMENSIONS

- Blade pitch: 33 mm
- Depth to fit: 46 mm
- Flange size: 40 mm
- Minimum dimensions: 150 x 150 mm

FIXING

- Brackets ref. 1428
- For louvres larger than approx. 3 m², a reinforcing mullion is required to suit span and windload

OPTIONS

- Water channel
- Drainage profile
- Removable insect mesh
- Filter
- Without flange
- Glazed-in louvre 428 [see p. 96]
- Stainless steel 304 insect screen 2,3x2,3 or mesh [10x10/20x20 mm] or without
- Insect screen or mesh in stainless steel 316

TYPICAL APPLICATIONS

- Applications where extreme strength and stick-proof are key parameters



TECHNICAL SPECIFICATIONS

All properties are valid for the standard version of the Louvre, unless otherwise stated.

Weatherability	[EN 13030]
Class for execution with mesh 6x6 mm and water channels [details see p. 12]	A4 [0.5 m/s]
Airflow	[EN 13030]
K-factor [entry]	66.10
K-factor [discharge]	66.10
C _e coefficient	0.123
C _d coefficient	0.123
Technical data	
Visual free area	59%
Physical free area	43%
IP class	IP2XD
IP class for version with mesh 2.3x2.3 mm and water channel (electrical installation at least 200 mm)	IP44

TECHNICAL DRAWINGS

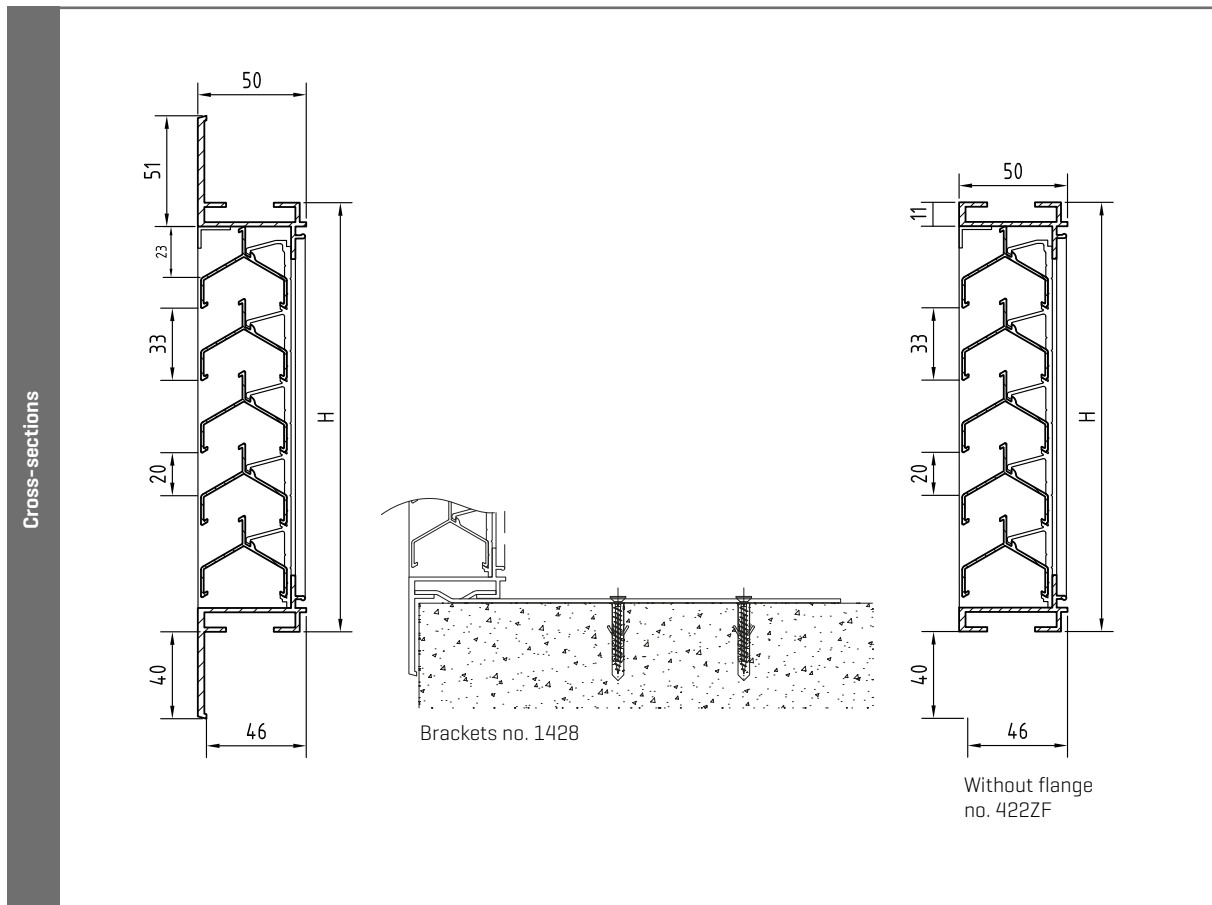

427 [427/1 - 427/2 - 427/3 - 427/4 - 427/5]

Built-in wall louvre, extra-heavy-duty series, with adjustable blades

BUILT-IN WALL
LOUVRE

ALUMINIUM



412 with filter option

MATERIAL

- Made from aluminium sections: AlMgSi 0.5 (according to EN 12020-2)
- Stainless steel 304 mesh [6 x 6 mm]
- Finishing: anodized in satin colour [20 micron] or powder-coated in any RAL or Syntha Pulvin colour [40 micron]

DIMENSIONS

- Depth to fit: 82 mm
- Maximum width in one piece: 1300 mm
- Minimum dimensions: 300 x 290 mm
- Flange size: 50 mm
- Preferred height = [multiple of 100] + 290 mm

Remark: the minimum height is dependant of the control option [see next p.].

FIXING

- Brackets ref. 429

OPTIONS

- Stainless steel insect screen 304 - 2.3 x 2.3 / 10 x 10 / 20 x 20 / without mesh
- Wire mesh in 316
- Without flange
- Glazed-in louvre 427GL [see p. 104]

CONTROL OPTIONS

- 427/1 Manual
- 427/2 Cable
- 427/3 Ultraflex
- 427/4 Motor 230 - 24V
- 427/5 Air pressure
- 427/6 Spring-return actuator 24V

TYPICAL APPLICATIONS

- Powers stations
- High buildings
- Controlled ventilation
- Production halls



Type 427/2



Type 427/3



Type 427/4



Type 427/5



Type 427/6

TECHNICAL SPECIFICATIONS

All properties are valid for the standard version of the Louvre, unless otherwise stated.

Airflow		(EN 13030)
K-factor [entry]		11.41
K-factor [discharge]		11.65
C _e coefficient		0.296
C _d coefficient		0.293
Technical data		
Visual free area		88%
Physical free area		53%



TECHNICAL DRAWINGS

Cross-sections

Type 427/1
Manual control
Minimum louvre height: 290 mm

Type 427/2
Cable control up to 2250 mm
Minimum louvre height: 390 mm

Type 427/3
Ultraflex control of max. 7 m
Minimum louvre height: 690 mm

Type 427/4
220 V/24 V motor control
Minimum louvre height: 390 mm

Type 427/5
Air pressure control
Minimum louvre height: 390 mm

Wall brackets no. 429

Without flange no. 427ZF

451

AVAILABLE UNTIL END OF STOCK

Built-in wall louvre, heavy-duty series

BUILT-IN WALL
LOUVRE

ALUMINIUM



MATERIAL

- Made from aluminium sections: AlMgSi 0.5 [according to EN 12020-2]
- Stainless steel 304 mesh [6 x 6 mm]
- Finishing: anodized in satin colour [20 micron] or powder-coated in any RAL or Syntha Pulvin colour [40 micron]

DIMENSIONS

- Blade pitch: 66 mm
- Depth to fit: 60 mm
- Flange size: 25 mm
- Minimum dimensions: 300 x 300 mm

FIXING

- Brackets ref. 429
- For louvres larger than approx. 3 m², a reinforcing mullion is required to suit span and windload

OPTIONS

- Water channel
- Drainage profile
- Removable insect mesh
- Filter
- Without flange
- Stainless steel 304 insect screen 2,3x2,3 or mesh [10x10/20x20 mm] or without
- Insect screen or mesh in stainless steel 316

TYPICAL APPLICATIONS

- Industrial, commercial with large blade pitch

TECHNICAL SPECIFICATIONS

All properties are valid for the standard version of the Louvre, unless otherwise stated.

Airflow		[EN 13030]
K-factor [entry]		14.24
K-factor [discharge]		11.77
C _e coefficient		0.265
C _d coefficient		0.291
Technical data		
Visual free area		70%
Physical free area		49%

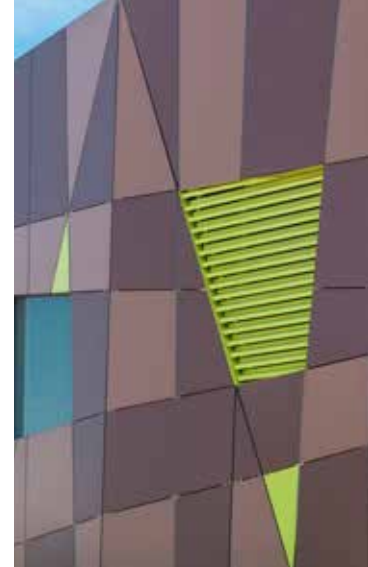

TECHNICAL DRAWINGS

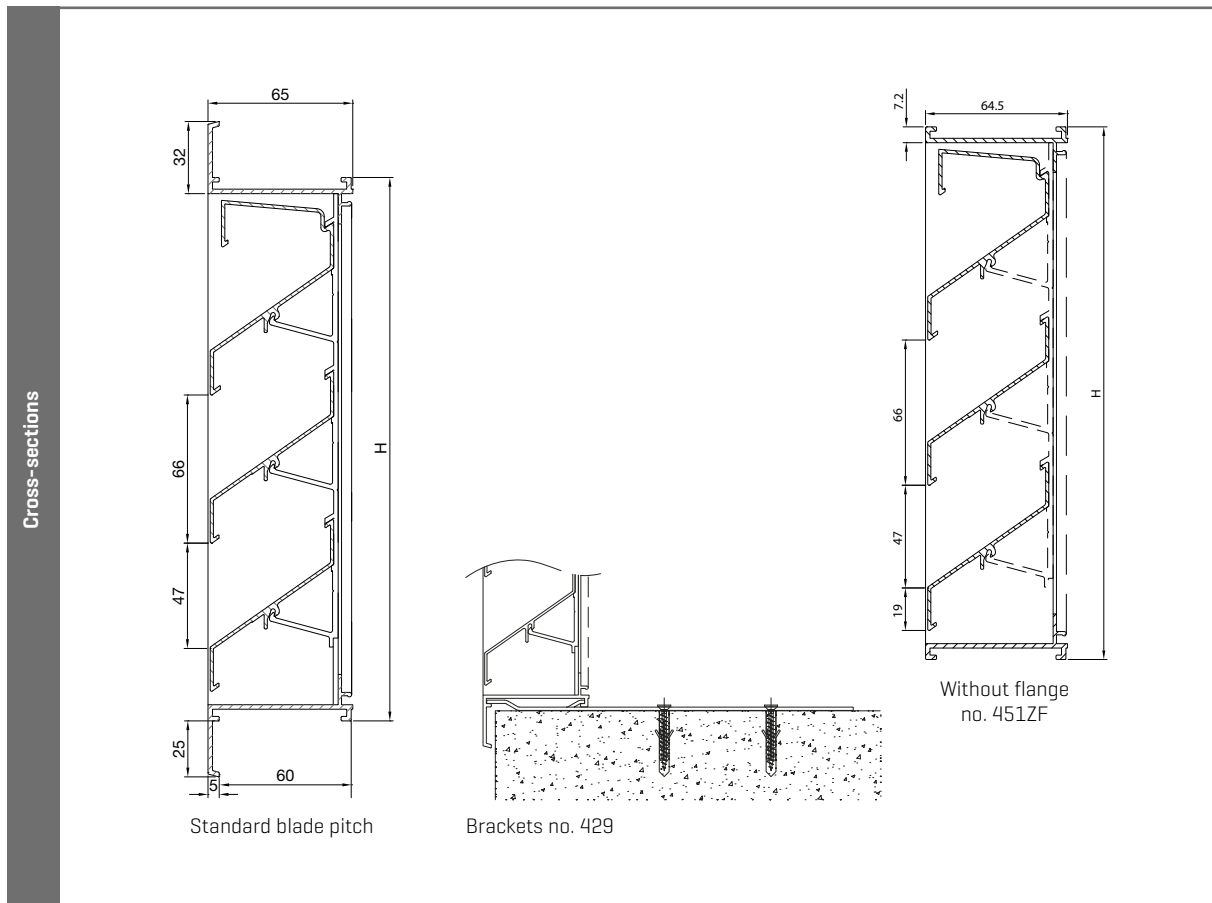

453

AVAILABLE UNTIL END OF STOCK

Built-in wall louvre, heavy-duty series, with aluminium coil blades

BUILT-IN WALL
LOUVRE

ALUMINIUM



MATERIAL

- Frame made from aluminium sections: AlMgSi 0.5 [according to EN 12020-2]
- Roll-formed aluminium coil blades
- Stainless steel 304 mesh [6 x 6 mm]
- Finishing: powder-coated in any RAL or Syntha Pulvin colour [40 micron]

DIMENSIONS

- Blade pitch: 65 mm
- Depth to fit: 60 mm
- Flange size: 25 mm
- Minimum dimensions: 300 x 300 mm

FIXING

- Brackets ref. 429
- For louvres larger than approx. 3 m², a reinforcing mullion is required to suit span and windload

OPTIONS

- Water channel
- Drainage profile
- Filter
- Without flange
- Stainless steel 304 insect screen 2,3x2,3 or mesh [10x10/20x20 mm] or without
- Insect screen or mesh in stainless steel 316

TYPICAL APPLICATIONS

- Aesthetical

TECHNICAL SPECIFICATIONS

All properties are valid for the standard version of the Louvre, unless otherwise stated.

Airflow		[EN 13030]
K-factor [entry]		13.92
K-factor [discharge]		17.22
C _e coefficient		0.268
C _d coefficient		0.241
Technical data		
Visual free area		69%
Physical free area		55%

TECHNICAL DRAWINGS

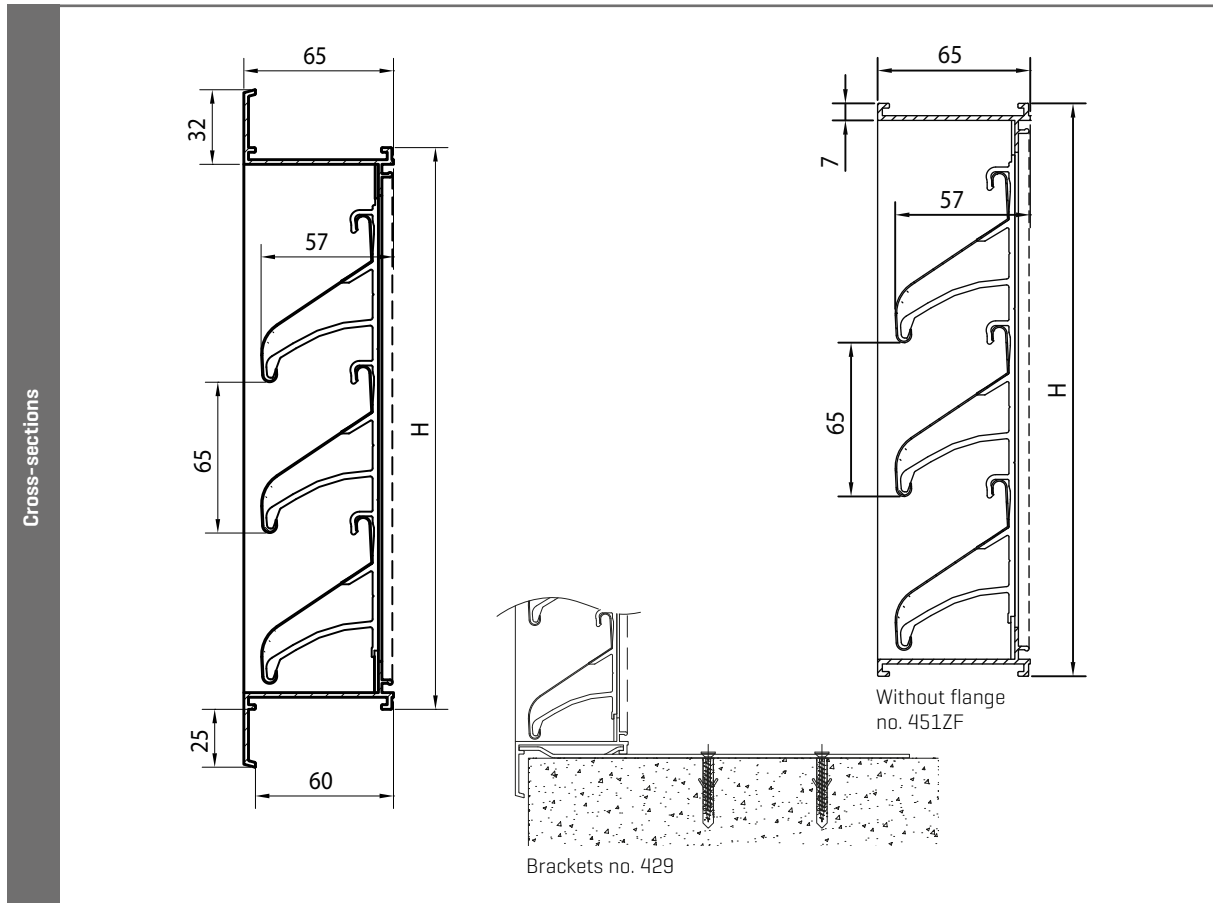

457

Built-in wall louvre, heavy-duty series

BUILT-IN WALL
LOUVRE

ALUMINIUM



MATERIAL

- Made from aluminium sections: AlMgSi 0.5 [according to EN 12020-2]
- Stainless steel 304 mesh [6 x 6 mm]
- Finishing: anodized in satin colour [20 micron] or powder-coated in any RAL or Syntha Pulvin colour [40 micron]

DIMENSIONS

- Blade pitch: 75 mm
- Depth to fit: 60 mm
- Flange size: 25 mm
- Minimum dimensions: 300 x 300 mm

FIXING

- Brackets ref. 429
- For louvres larger than approx. 3 m², a reinforcing mullion is required to suit span and windload

OPTIONS

- Water channel
- Drainage profile
- Removable insect mesh
- Filter
- Without flange
- Stainless steel 304 insect screen 2,3x2,3 or mesh [10x10/20x20 mm] or without
- Insect screen or mesh in stainless steel 316

TYPICAL APPLICATIONS

- Industrial, commercial with large blade pitch

TECHNICAL SPECIFICATIONS

All properties are valid for the standard version of the Louvre, unless otherwise stated.

Airflow		[EN 13030]
K-factor [entry]		13,13
K-factor [discharge]		14,24
C _e coefficient		0,276
C _d coefficient		0,265
Technical data		
Visual free area		75%
Physical free area		52%

TECHNICAL DRAWINGS

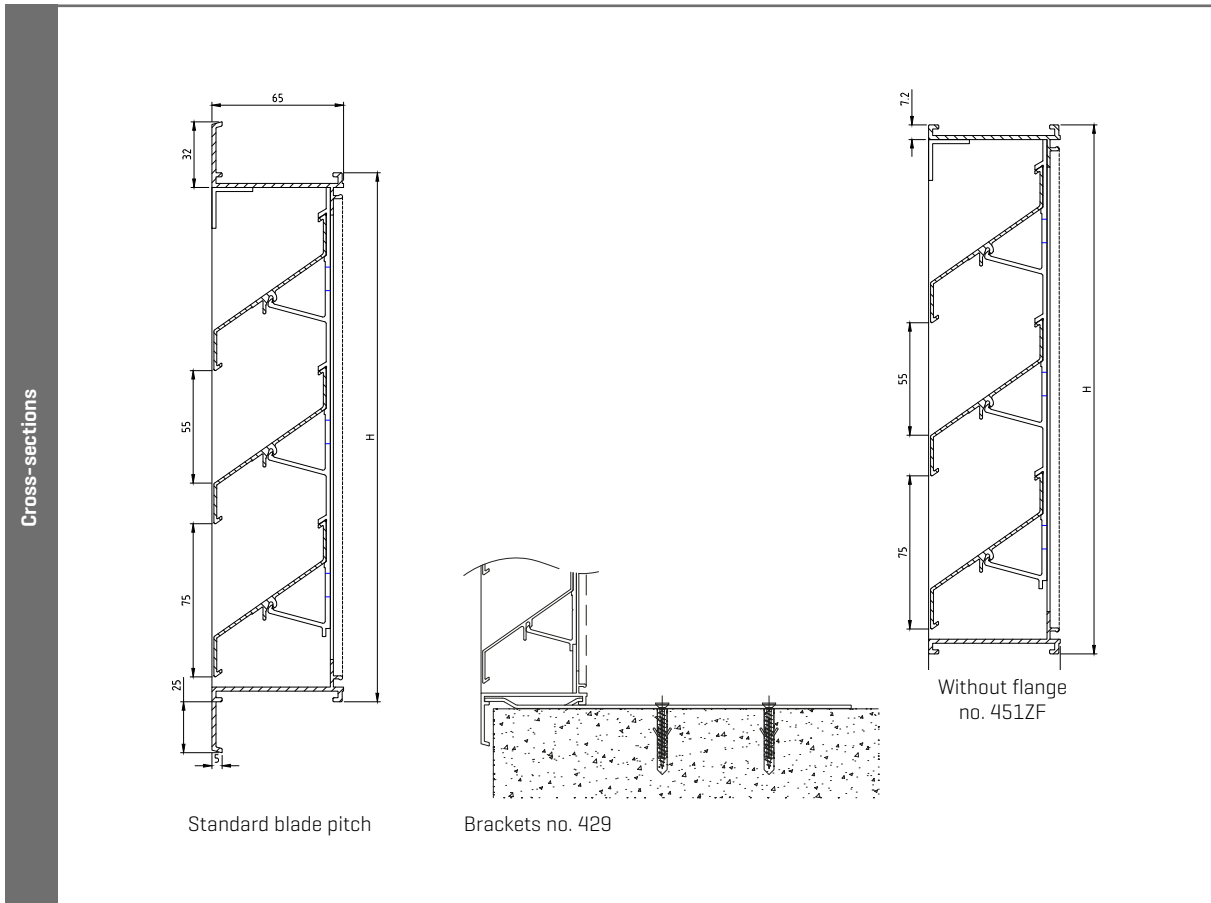

468 SA

Sand-trap louvre

BUILT-IN WALL
LOUVRE

ALUMINIUM



MATERIAL

- Made from aluminium sections: AlMgSi 0.5 [according to EN 12020-2]
 - Stainless steel 304 insect mesh [2.3 x 2.3 mm]
 - Finishing: anodized [20 micron] or powdercoated in any RAL or Syntha Pulvin colour [40 micron]
 - Vertically mounted blades. No rivets visible from the front.
 - Standard equipped with sand rejection sill, finished in the same colour as the louvre
- Note: when anodised, slight colour difference between sand rejection sill and louvre*

DIMENSIONS

- Blade pitch: 85 mm
 - Depth to fit: 60 mm
 - Flange size: 25 mm
 - Minimum dimensions: 185 x 185 mm
 - Width = [multiple of 42,5] + 185mm
- Remark :*
- symmetric louvre when the multiple is even
 - asymmetric louvre when the multiple is odd
- Maximum dimensions: 2012,5 x 1200 mm
- Remark : at a maximum wind load of 2kN/m²*

FIXING

- Brackets ref 429 included

OPTIONS

- Anti-dust filter cassette class G4
- Controllable airflow modules mounted on backside [type / VA]
- Without flange
- Stainless steel 304 or mesh [6x6/10x10/20x20 mm] or without
- Insect screen or mesh in stainless steel 316

TYPICAL APPLICATIONS

- Coastal area
- Dusty & polluted areas
- HVAC
- Power stations & high-voltage stations



TECHNICAL SPECIFICATIONS

All properties are valid for the standard version of the Louvre, unless otherwise stated.

Sand-resistance		(EN 13181)
Suction air velocity		
0 m/s		97%
0.5 m/s		94%
Airflow		(EN 13030)
K-factor [entry]		115.62
K-factor [exhaust]		115.62
C _e coefficient		0.093
C _d coefficient		0.093
Technical data		
Visual free area		29%
Physical free area		29%
IP class		IP2XD



TECHNICAL DRAWINGS

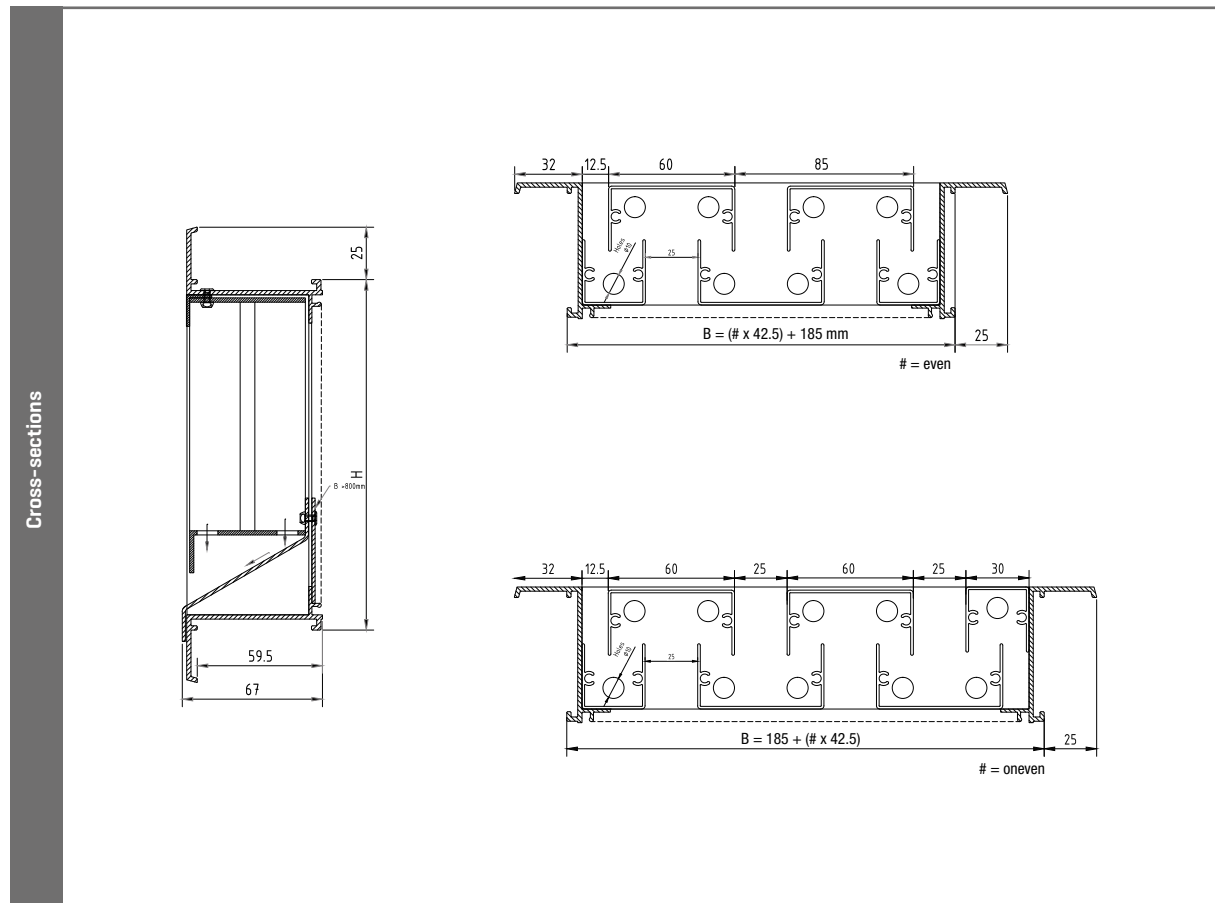

480

High-airflow built-in wall louvres

BUILT-IN WALL
LOUVRE

ALUMINIUM



MATERIAL

- Made from aluminium sections: AlMgSi 0.5 [according to EN 12020-2]
- Stainless steel 304 mesh [6 x 6 mm]
- Finishing: anodized in satin colour [20 micron] or powder-coated in any RAL or Syntha Pulvin colour [40 micron]

DIMENSIONS

- Blade pitch: 60 mm
- Depth to fit: 82 mm
- Flange size: 50 mm
- Minimum dimensions: 300 x 300 mm

FIXING

- Brackets ref. 429
- For louvres larger than approx. 3 m², a reinforcing mullion is required to suit span and windload

OPTIONS

- Water channel
- Drainage profile
- Removable mesh
- Filter
- Without flange
- Glazed-in louvre 483 [see p. 98]
- Stainless steel 304 insect screen 2,3x2,3 or mesh [10x10/20x20 mm] or without
- Insect screen or mesh in stainless steel 316

TYPICAL APPLICATIONS

- Underground parking
- Industrial applications



TECHNICAL SPECIFICATIONS

All properties are valid for the standard version of the Louvre, unless otherwise stated.

Airflow	[EN 13030]
K-factor [entry]	4,60
K-factor [discharge]	5,17
C _e coefficient	0,466
C _d coefficient	0,440
Technical data	
Visual free area	90%
Physical free area	76%
IP class [louvre with mesh; electrical installation at least 180 mm from louvre]	IP2XD

AIRFLOW

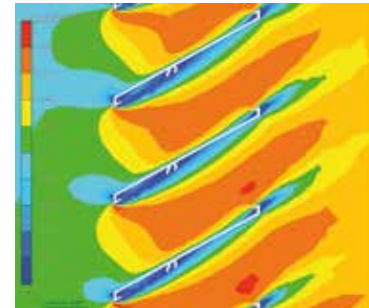

Supply

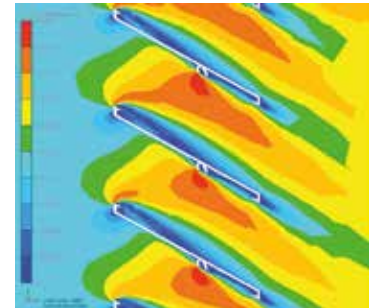

Discharge

TECHNICAL DRAWINGS

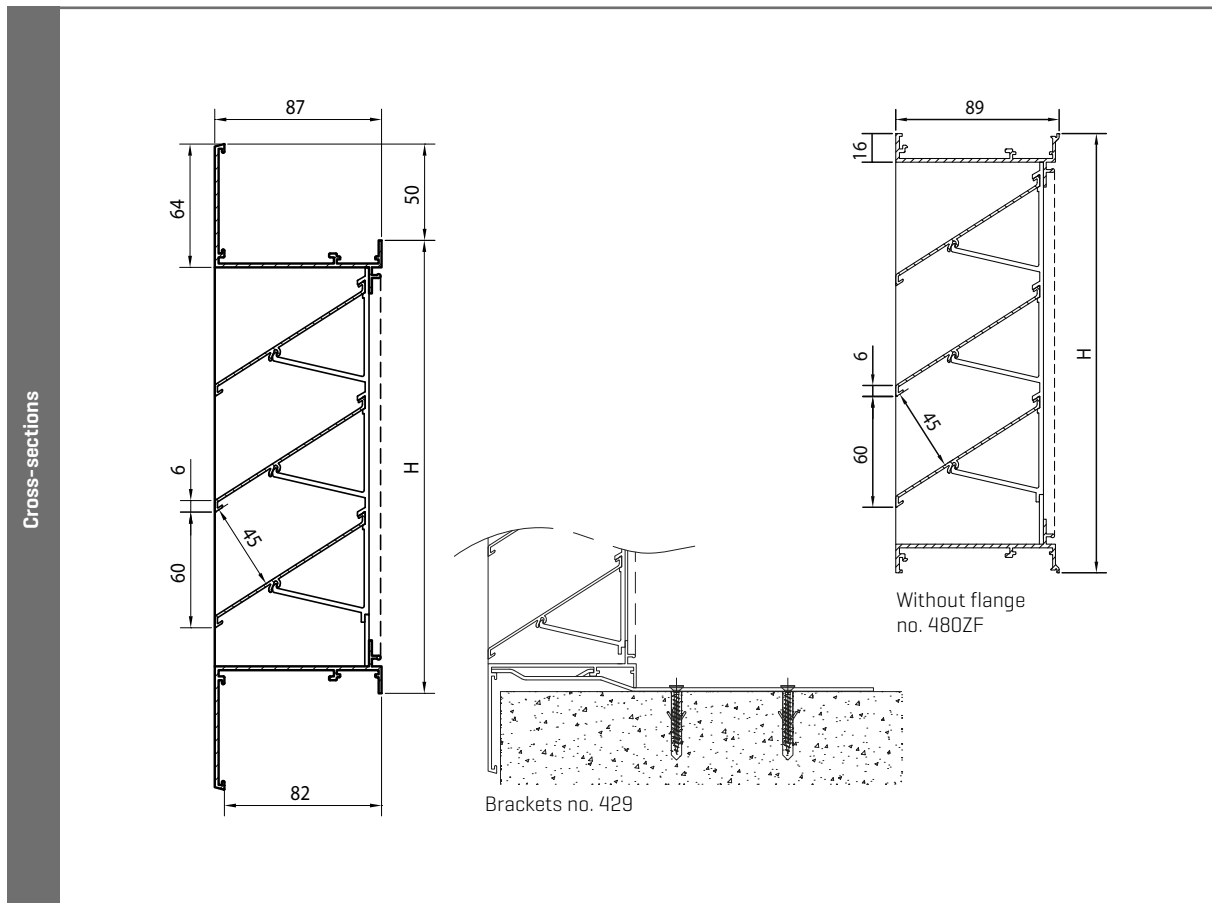

481

Built-in wall louvre, heavy-duty series

BUILT-IN WALL
LOUVRE

ALUMINIUM



MATERIAL

- Made from aluminium sections: AlMgSi 0.5 [according to EN 12020-2]
- Stainless steel 304 insect screen [2.3 x 2.3 mm]
- Finishing: anodized in satin colour [20 micron] or powder-coated in any RAL or Syntha Pulvin colour [40 micron]

DIMENSIONS

- Blade pitch: 50 mm
- Depth to fit: 46 mm
- Flange size: 40 mm
- Minimum dimensions: 150 x 150 mm

FIXING

- Brackets ref. 1428
- For louvres larger than approx. 3 m², a reinforcing mullion is required to suit span and windload

OPTIONS

- Water channel
- Drainage profile
- Removable mesh
- Filter
- Without flange
- Glazed-in louvre 484 [see p. 100]
- Stainless steel 304 mesh [6x6/10x10/20x20 mm] or without
- Insect screen or mesh in stainless steel 316

TECHNICAL SPECIFICATIONS

All properties are valid for the standard version of the Louvre, unless otherwise stated.

Airflow		[EN 13030]
K-factor [entry]		9.59
K-factor [discharge]		10.01
C _e coefficient		0.323
C _d coefficient		0.316
Technical data		
Visual free area		70%
Physical free area		60%
IP class [louvre with mesh; electrical installation at 105 mm at least]		IP2XD



TECHNICAL DRAWINGS

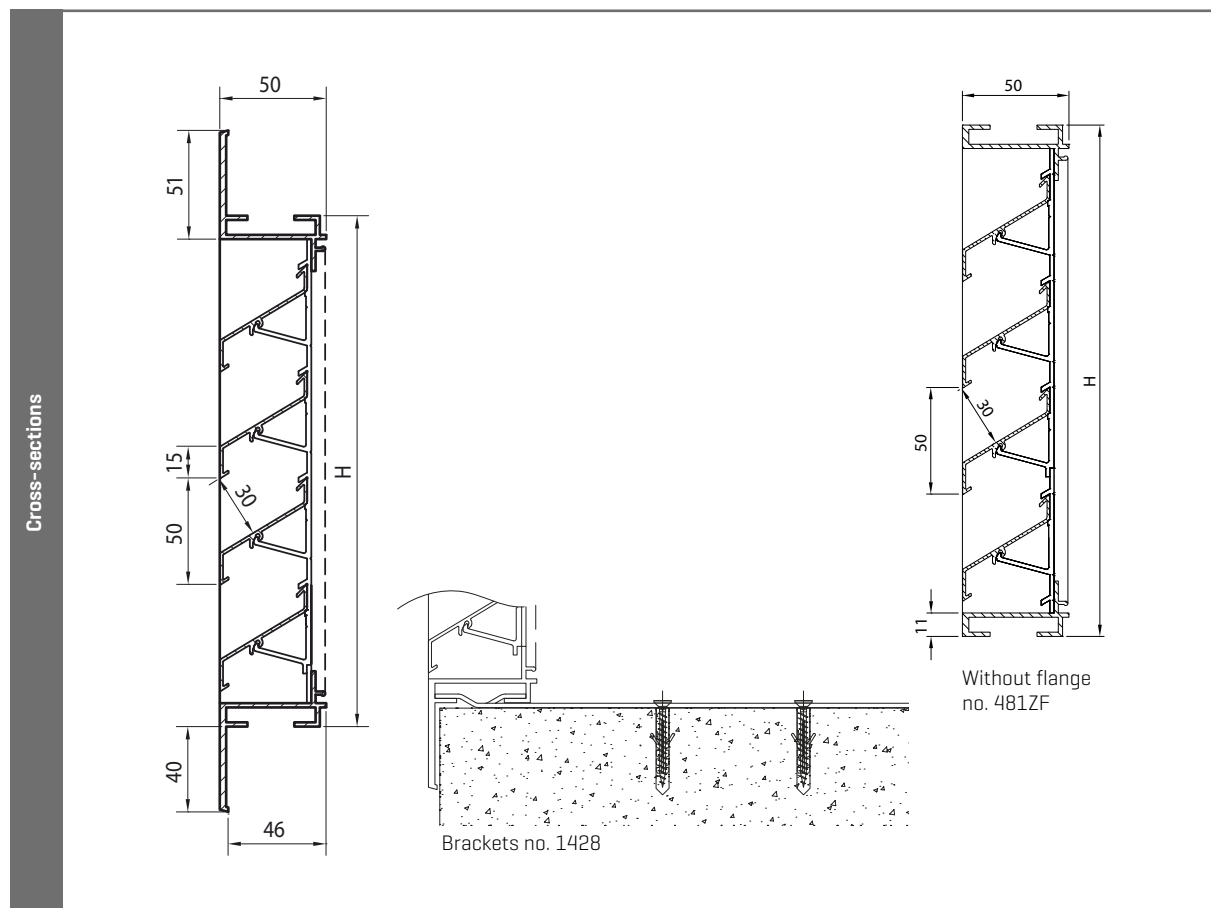

511

AVAILABLE UNTIL END OF STOCK

Built-in wall louvre, galvanised steel

BUILT-IN WALL
LOUVRE



GALVANISED
STEEL

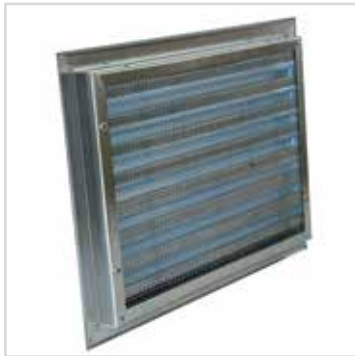

MATERIAL

- Made from steel plate
- Electroplating: 10 micron FeZn12C
- Steel mesh [5 x 5 mm]
- Finishing: no powder-coating possible

DIMENSIONS

- Blade pitch: 34 mm
- Depth to fit: 28 mm
- Flange size: 25 mm
- No made to measure

TECHNICAL SPECIFICATIONS

All properties are valid for the standard version of the Louvre, unless otherwise stated.

Airflow		[EN 13030]
K-factor [entry]		92.91
K-factor [discharge]		84.73
C _e coefficient		0.104
C _d coefficient		0.109
Technical data		
Visual free area		61%
Physical free area		43%
Dimensions [W x H] mm		Galvanised steel
200 x 200		00051122
300 x 300		00051133
400 x 200		00051142

Note: only available in the sizes listed above.

TECHNICAL DRAWINGS

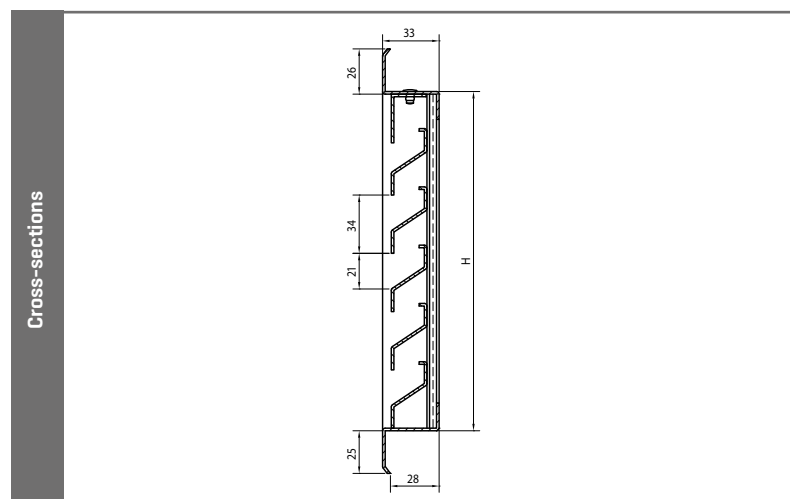



Built-in wall louvre, heavy-duty series 481 (see p. 50)

521

AVAILABLE UNTIL END OF STOCK

Wall louvre, heavy-duty series, galvanised steel

BUILT-IN WALL
LOUVRE

GALVANISED
STEEL



MATERIAL

- Made from steel plate
- Electroplating: 10 micron FeZn12C
- Finishing: powder coating in any RAL or Syntha Pulvin colour (min 40 microns)
- Steel mesh [13 x 13 mm]

DIMENSIONS

- Pitch: 50 mm
- Depth to fit: 43 mm
- Flange size: 40 mm
- Minimum dimensions: 200 x 200 mm
- Maximum dimensions: height 2500 mm; width 2100 mm

FIXING

- Brackets pre-fitted to the frame

TYPICAL APPLICATIONS

- Basic louvre
- Economic solution
- Containers
- Paintable

STOCK MODELS

Dimensions [W x H] mm	Galvanised steel
400 x 400	00152144
500 x 500	00152155
600 x 600	00152166
1000 x 1000	15211010

TECHNICAL SPECIFICATIONS

All properties are valid for the standard version of the Louvre, unless otherwise stated.

Airflow		[EN 13030]
K-factor [entry]		14.91
K-factor [discharge]		16.00
C _e coefficient		0.259
C _d coefficient		0.250
Technical data		
Visual free area		79%
Physical free area		54%

TECHNICAL DRAWINGS

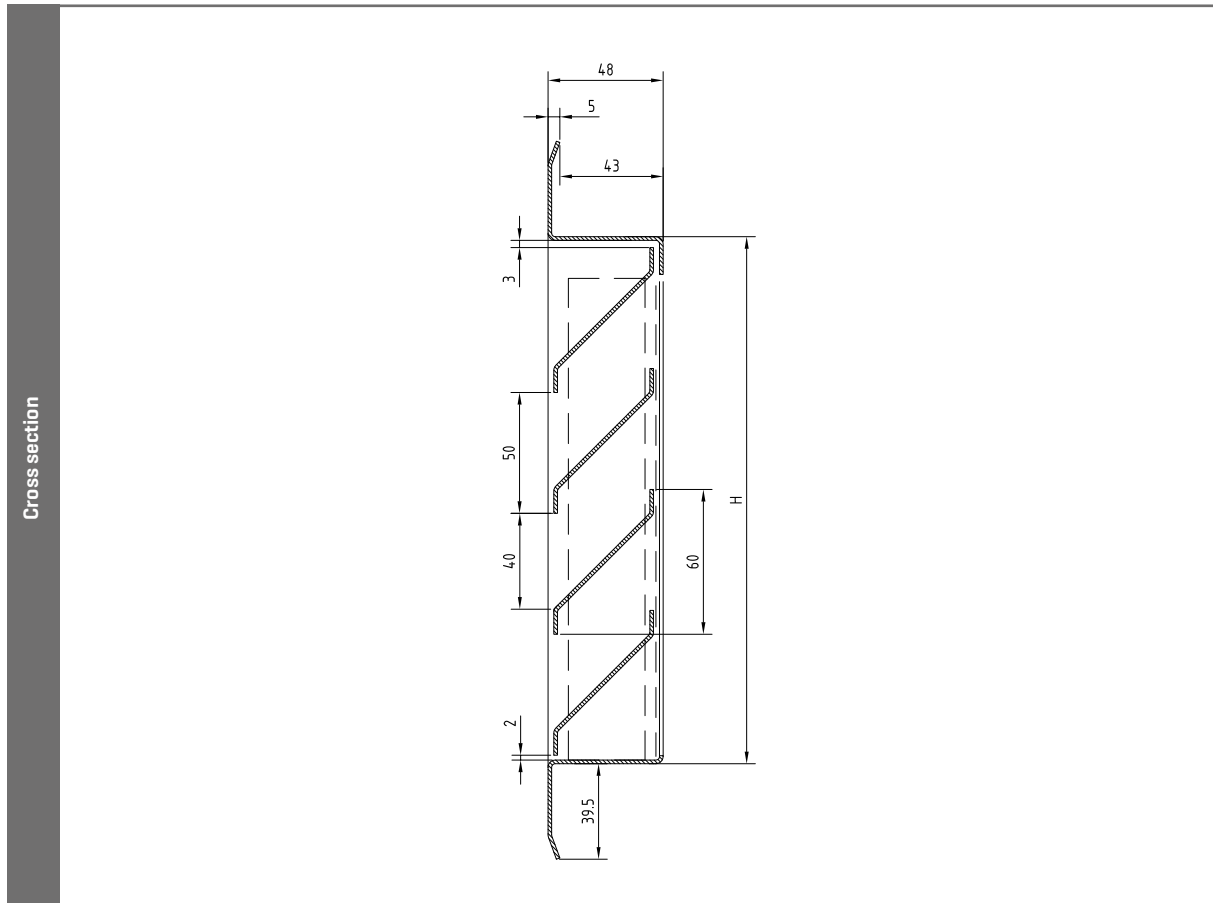

621

Wall louvre, stainless steel

AVAILABLE UNTIL END OF STOCK

BUILT-IN WALL
LOUVRE

STAINLESS
STEEL



MATERIAL

- Made from stainless steel 316 L
- Stainless steel 304 mesh (13 x 13 mm)
- Lacquering not possible

DIMENSIONS

- Pitch: 50 mm
- Depth to fit: 43 mm
- Flange size: 40 mm
- Minimum dimensions: 250 x 250 mm
- Maximum dimensions: 2000 x 2000 mm

FIXING

- Brackets pre-fitted to the frame

TYPICAL APPLICATIONS

- Food sector
- Chemical sector
- Hospitals
- Environment with high corrosion

TECHNICAL SPECIFICATIONS

All properties are valid for the standard version of the Louvre, unless otherwise stated.

Airflow		[EN 13030]
K-factor [entry]		14.91
K-factor [discharge]		16.00
C _e coefficient		0.259
C _d coefficient		0.250
Technical data		
Visual free area		79%
Physical free area		54%

TECHNICAL DRAWINGS

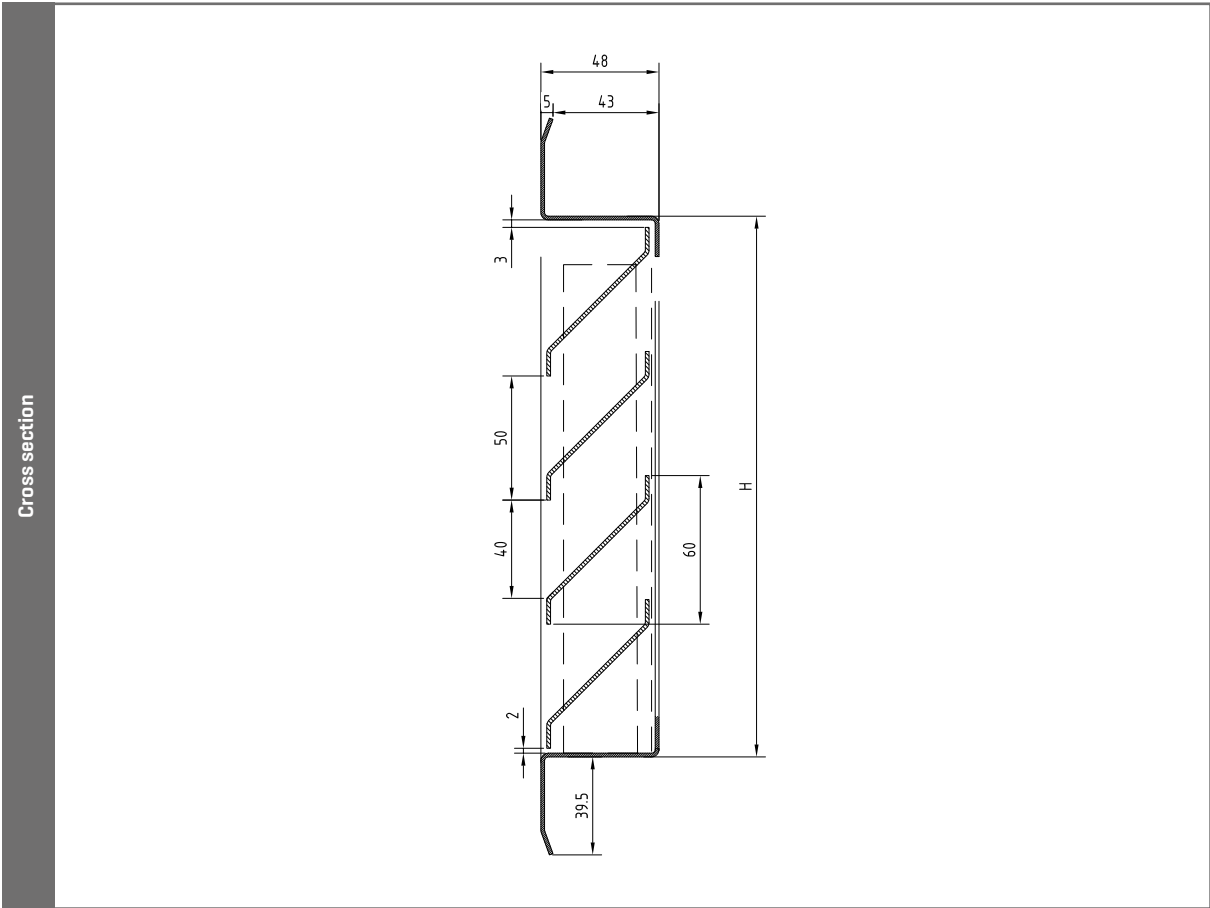

450

Extreme weatherable louvre

WATER-
RESISTANT
LOUVRE

ALUMINIUM



Louvre 450 delivers the best performance on watertightness combined with a very high airflow.

MATERIAL

- Made from aluminium sections: AlMgSi 0.5 [according to EN 12020-2]
- Stainless steel 304 insect mesh [2.3 x 2.3 mm]
- Finishing: anodized in satin colour [20 micron] or powder coated in any RAL or Syntha Pulvin colour [40 micron],
- Fitted with a water channel at top and bottom to enhance drainage

DIMENSIONS

- Blade pitch: 50 mm
- Depth to fit: 159 mm
- Flange size: 52 mm
- Minimum dimensions: 200 x 230 mm
- Preferred height: [multiple of 50] + 230 mm

FIXING

- Brackets ref. 1428 included

OPTIONS

- Without flange
- Glazing-in louvre available on request.
- In combination with the L.050WS dummy blade
- Stainless steel 304 mesh [6x6/10x10/20x20 mm] or without
- Insect screen or mesh in stainless steel 316
- Filter

TYPICAL APPLICATIONS

- Data and IT centres
- Power stations
- Substations
- Coastal applications



TECHNICAL SPECIFICATIONS

All properties are valid for the standard version of the Louvre, unless otherwise stated.

Weatherability		[EN 13030]
Class [details see p. 12]		A2 [3 m/s]
Airflow		[EN 13030]
K-factor [entry]		10.47
K-factor [discharge]		16.52
C _e coefficient		0.309
C _d coefficient		0.246
Technical data		
Visual free area		±80%
Physical free area		57%
IP class		IP44
IP class for non-standard versions		IP2XD

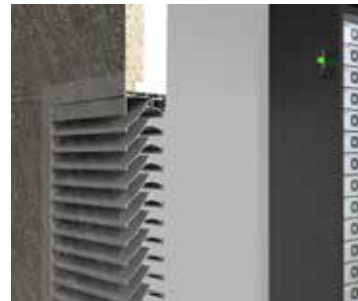

Water channel

TECHNICAL DRAWINGS

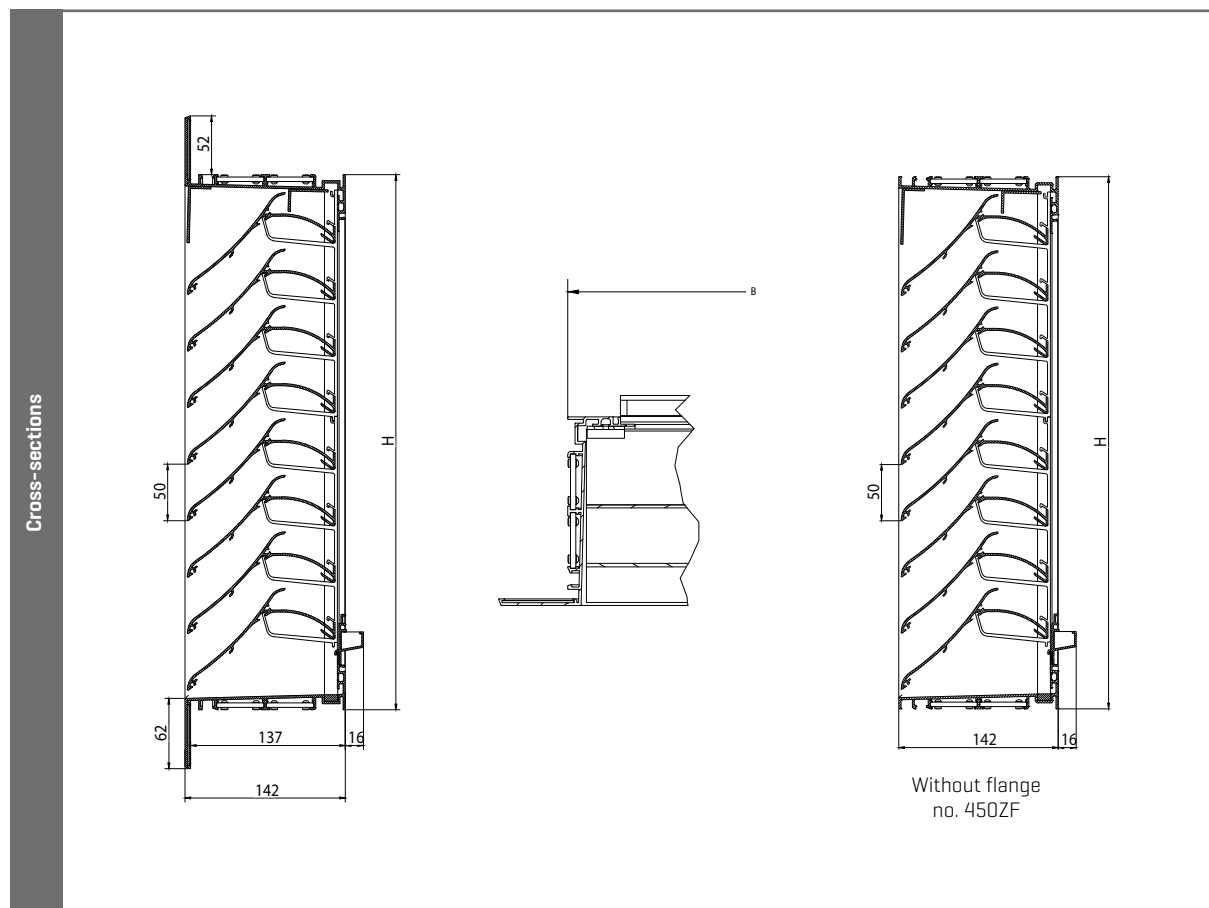

450V

Extreme weatherable louvre

WATER-
RESISTANT
LOUVRE

ALUMINIUM



Extremely water-resistant louvre with vertical blades combine an extreme water resistance with an incredibly high air flow.

MATERIAL

- Made from aluminium profiles AlMgSi 0.5 [in accordance with EN 12020-2]
- Standard stainless steel insect screen 304 - 2.3 x 2.3 mm
- Finishing: anodized in satin colour [20 micron] or powdercoated in any RAL or Syntha Pulvin colour [40 micron]
- Fitted with water channel as standard

DIMENSIONS

- Blade pitch: 50 mm
- Depth to fit: 159 mm
- Flange size: 52 mm
- Minimum dimensions W x H: 230 x 200 mm
- Preferred width: [multiples of 50] + 230 mm

FIXING

- Wall brackets no. 1428 included
- A reinforcing back structure is required for louvres that are wider than 2395 mm

OPTIONS

- Stainless steel 304 mesh - 6 x 6 mm [please note, this will impact the properties]
- Wire mesh in 316
- Without flange
- Removable insect screen
- Filter
- Glazed-in louvre upon request

TYPICAL APPLICATIONS

- Data centres
- Electric power stations
- Hospitals
- IT applications



TECHNICAL SPECIFICATIONS

All properties are valid for the standard version of the Louvre, unless otherwise stated.

Weatherability		[EN 13030]
Class [details see p. 12]		A2 [4 m/s]
Airflow		[EN 13030]
K-factor [entry]		10.75
K-factor [discharge]		16.52
C _e coefficient		0.305
C _d coefficient		0.246
Technical data		
Visual free area		±80%
Physical free area		57%
IP class		IP2XD



Water channel

TECHNICAL DRAWINGS

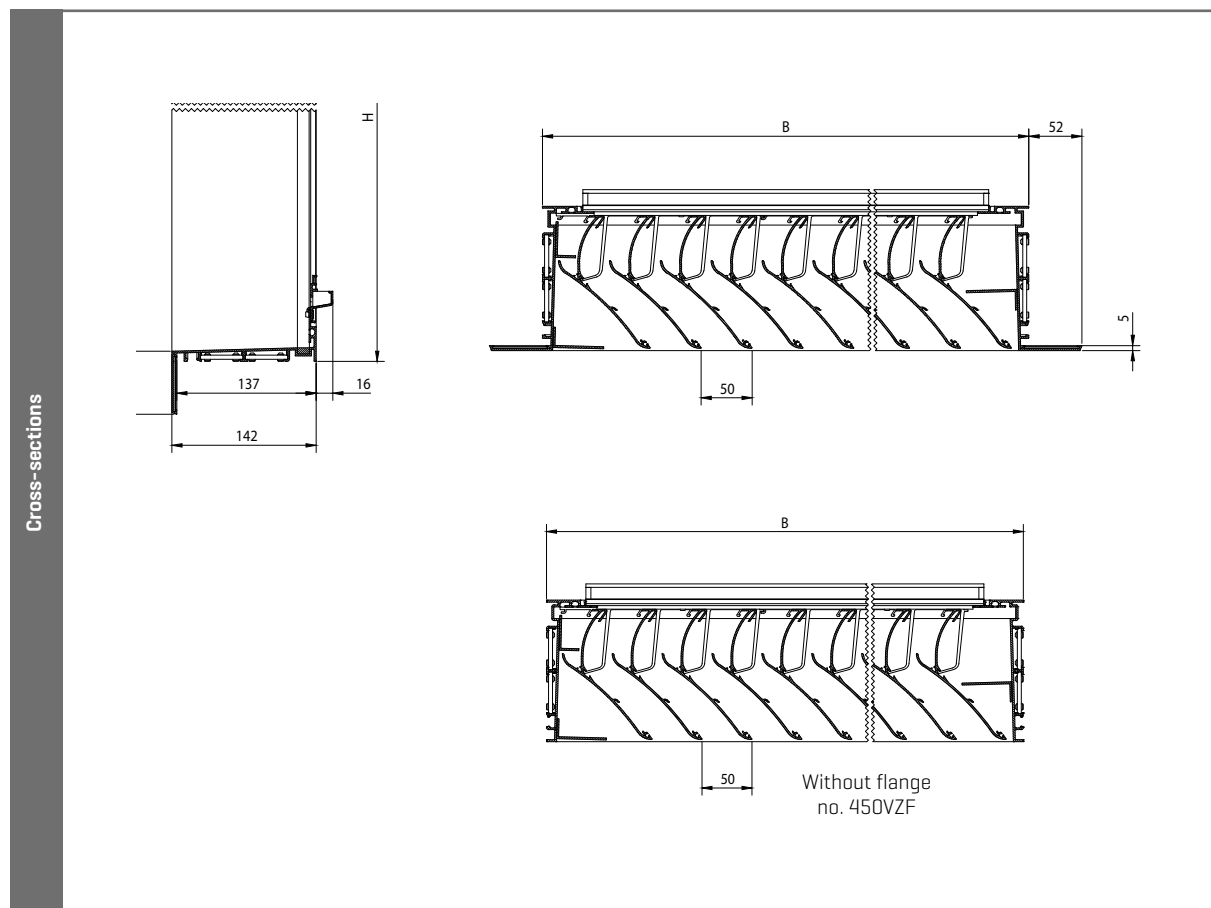

452

Wall louvre, heavy-duty series with chevron section blades

WATER-
RESISTANT
LOUVRE

ALUMINIUM



MATERIAL

- Made from aluminium sections: AlMgSi 0.5 [according to EN 12020-2]
- Stainless steel 304 mesh [6 x 6 mm]
- Finishing: anodized in satin colour [20 micron] or powder-coated in any RAL or Syntha Pulvin colour [40 micron]

DIMENSIONS

- Blade pitch: 66 mm
- Depth to fit: 82 mm
- Flange size: 50 mm
- Minimum dimensions: 300 x 310 mm

FIXING

- Brackets ref. 429
- For louvres taller than approx. 3 m², a reinforcing mullion is required to suit span and windload

OPTIONS

- Water channel
- Drainage profile
- Removable insect mesh
- Filter
- Without flange
- Glazed-in louvre available on request
- Stainless steel 304 insect screen 2.3x2.3 mm or mesh [10x10/20x20 mm] or without
- Insect screen or mesh in stainless steel 316

TYPICAL APPLICATIONS

- Application where strength, stick-proof and excellent weatherability are important selection criteria
- High-voltage cabins
- HVAC
- No see-through



TECHNICAL SPECIFICATIONS

All properties are valid for the standard version of the Louvre, unless otherwise stated.

Weatherability		[EN 13030]
Class for version with mesh 6x6 mm and water channel <i>[details see p. 12]</i>		A4 [1 m/s]
Airflow		[EN 13030]
K-factor [entry]		66.1
K-factor [discharge]		79.7
C _e coefficient		0.123
C _d coefficient		0.112
Technical data		
Visual free area		70%
Physical free area		41%
IP class		IP2XD
IP class for version with mesh 2.3x2.3 mm and water channel (electrical installation at least 250 mm)		IP44

TECHNICAL DRAWINGS

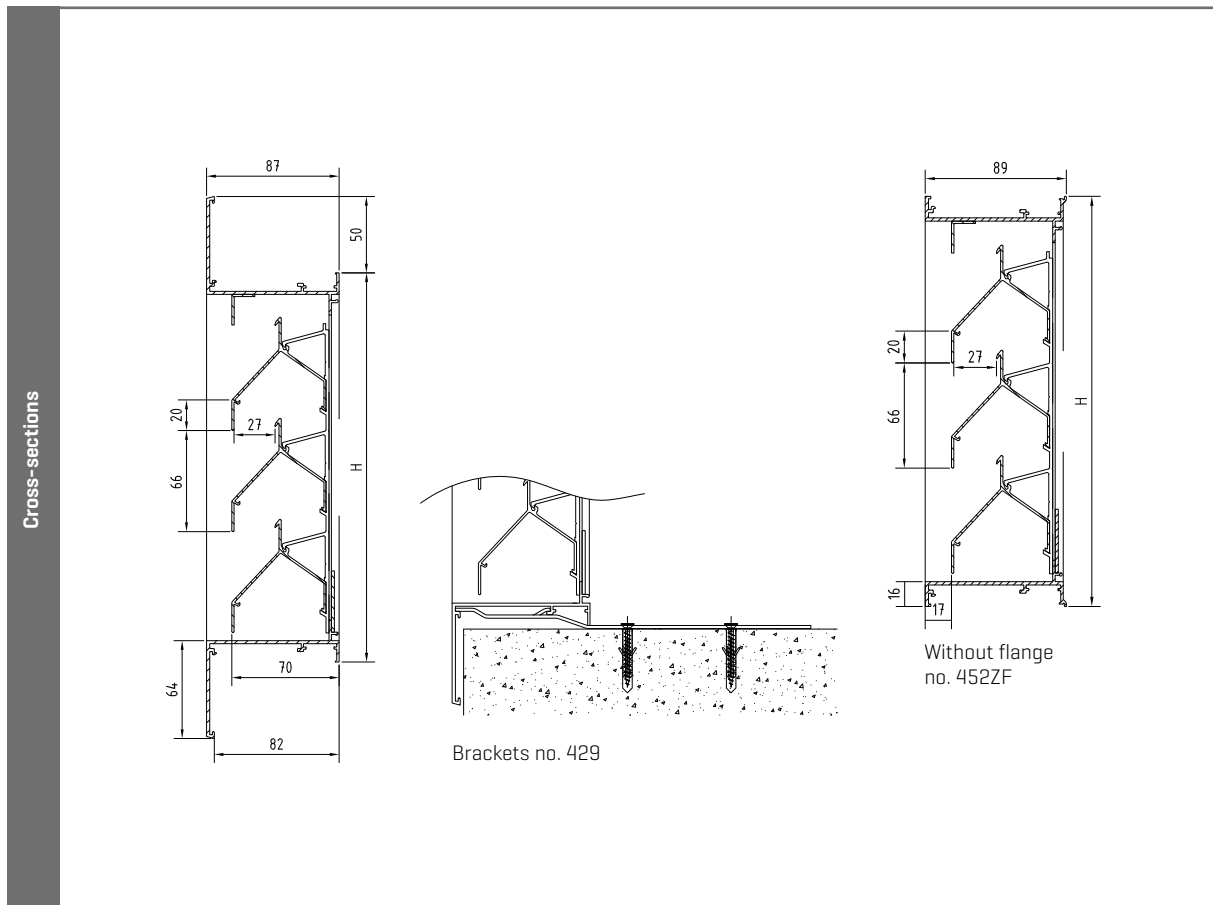

452V

AVAILABLE UNTIL END OF STOCK

Wall louvre, heavy-duty series with vertical chevron section blades

WATER-
RESISTANT
LOUVRE

ALUMINIUM



Vertical blades - 452V

MATERIAL

- Made from aluminium sections: AlMgSi 0.5 [according to EN 12020-2]
- Insect screen [2,3 x 2,3 mm]
- Finishing: anodized in satin colour [20 micron] or powder-coated in any RAL or Syntha Pulvin colour [40 micron]
- Standard equipped with water channel

DIMENSIONS

- Blade pitch: 66 mm
- Depth to fit: 82 mm
- Flange size: 50 mm
- Minimum dimensions: 310 x 300 mm

FIXING

- Brackets ref. 429
- For louvres taller than approx. 3 m², a reinforcing mullion is required to suit span and windload

OPTIONS

- Drainage profile
- Removable insect mesh
- Filter
- Without flange
- Glazed-in louvre available on request
- Stainless steel 304 mesh [6x6/10x10/20x20 mm] or without
- Insect screen or mesh in stainless steel 316

TYPICAL APPLICATIONS

- Application where strength, stick-proof and excellent weatherability are important selection criteria
- High-voltage cabins
- HVAC
- No see-through



TECHNICAL SPECIFICATIONS

All properties are valid for the standard version of the Louvre, unless otherwise stated.

Weatherability		[EN 13030]
Class for execution with mesh 2.3x2.3 mm and water channel (details see p. 12)		A4 [1.5 m/s]
Airflow		[EN 13030]
K-factor [entry]		60.1
K-factor [discharge]		79.9
C _e coefficient		0.129
C _d coefficient		0.114
Technical data		
Visual free area		70%
Physical free area		41%
IP class		IP44
IP class for non-standard versions		IP2XD

TECHNICAL DRAWINGS

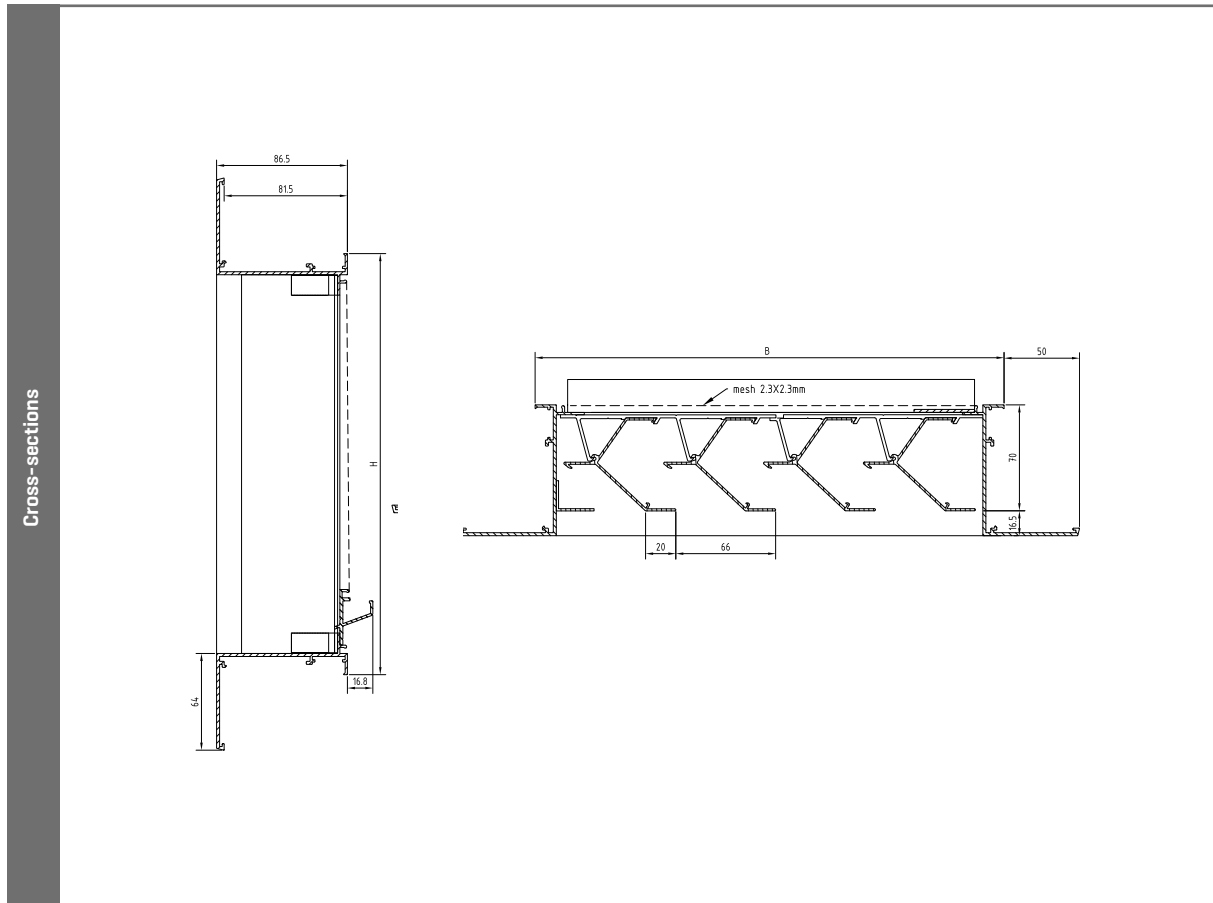

475

AVAILABLE UNTIL END OF STOCK

Louvre with excellent weatherability properties,
ideal for discharge applications

WATER-
RESISTANT
LOUVRE

ALUMINIUM



MATERIAL

- Made from aluminium sections: AlMgSi 0,5 [according to EN 12020-2]
- Stainless steel 304 insect mesh [2,3 x 2,3 mm]
- Finishing: anodized in satin colour [20 micron] or powder coated in any RAL or Syntha Pulvin colour [40 micron]
- Fitted with a water channel to enhance drainage

DIMENSIONS

- Blade pitch: 75 mm
- Depth to fit: 82 mm
- Flange size: 50 mm
- Minimum dimensions: 230 x 295 mm
- Maximum dimension: 4000 mm [W or H] with $S_{max.} = 3,5 \text{ m}^2$
- Preferred height: [multiple of 75] + 295 mm

FIXING

- Brackets ref. 429 included

OPTIONS

- Stainless steel 304 mesh [6x6/10x10/20x20 mm] or without [remark, this influences the properties]
- Drainage profile
- Insect screen or mesh in stainless steel 316
- Filter
- Without flange
- Glazed-in louvre available on request: *see p. 68*

TYPICAL APPLICATIONS

- Industrial applications where good ventilation needs to be combined with excellent weatherability



TECHNICAL SPECIFICATIONS

All properties are valid for the standard version of the Louvre, unless otherwise stated.

Weatherability		[EN 13030]
Class [details see p. 12]		A2 [0 m/s]
Airflow		[EN 13030]
K-factor [entry]		10.89
K-factor [discharge]		10.41
C _e coefficient		0.303
C _d coefficient		0.310
Technical data		
Physical free area		53%

TECHNICAL DRAWINGS

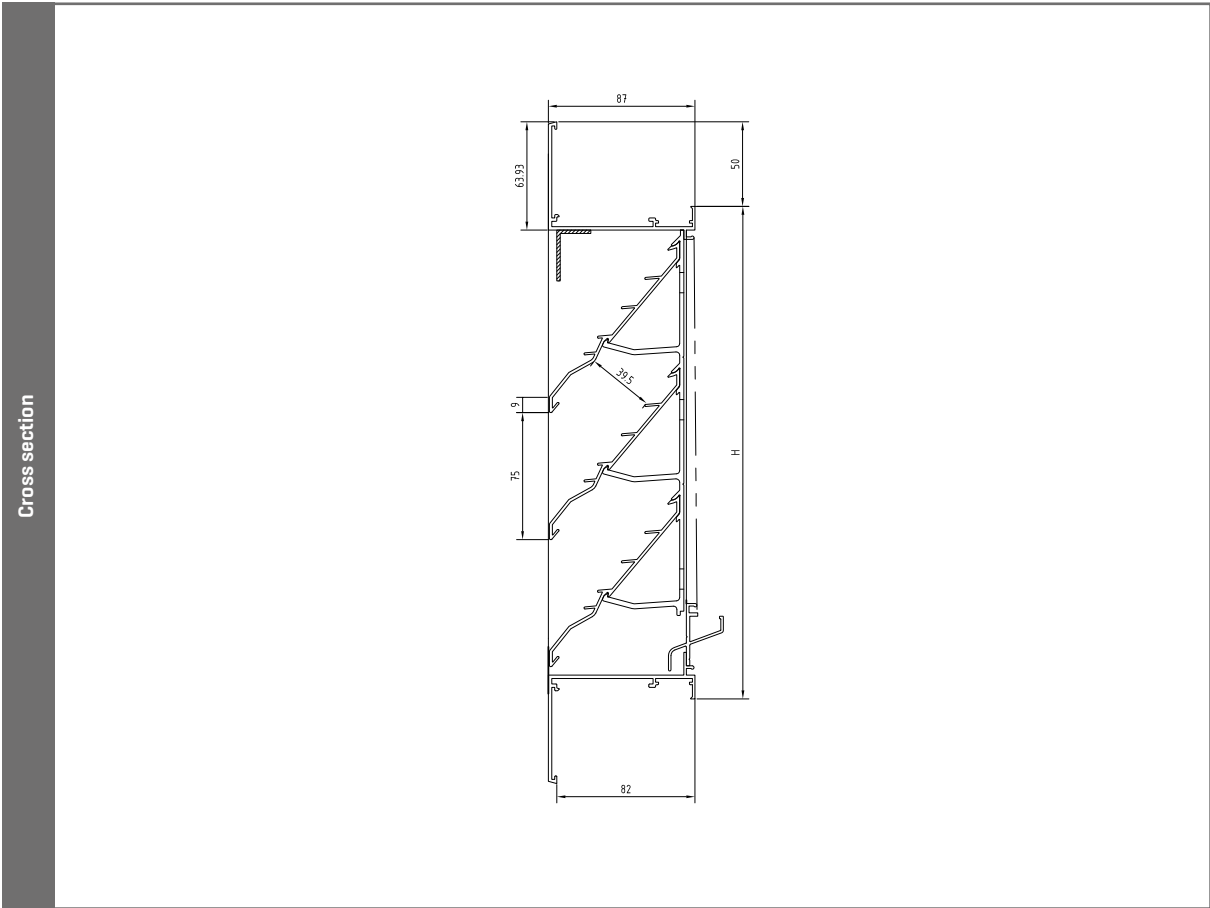

475GL

AVAILABLE UNTIL END OF STOCK

Glazed-in louvre with excellent weatherability properties,
ideal for discharge applications

WATER-
RESISTANT
LOUVRE

ALUMINIUM



MATERIAL

- Made from aluminium sections: AlMgSi 0,5 [according to EN 12020-2]
- Stainless steel 304 insect mesh [2,3 x 2,3 mm]
- Finishing: anodized in satin colour [20 micron] or powder coated in any RAL or Syntha Pulvin colour [40 micron]
- Fitted with a water channel to enhance drainage

DIMENSIONS

- Blade pitch: 75 mm
- Frame thickness: 24 mm [thicknesses from 8 till 50 mm upon request]
- Minimum dimensions:
 - 475GL/24: 330 x 380 mm
 - 475GL/8-50: 330 x 395 mm
- Maximum dimension: 4000 mm [W or H] with $S_{max} = 3,5 m^2$
- Preferred height:
 - 475GL/24: [multiple of 75] + 380 mm
 - 475GL/8-50: [multiple of 75] + 395 mm

FIXING

- Suitable for 24 mm glazing sections. Other thicknesses on request.

OPTIONS

- Stainless steel 304 mesh [6x6/10x10/20x20 mm] or without [remark, this influences the properties]
- Insect screen or mesh in stainless steel 316
- Removable insect mesh
- Filter



TECHNICAL SPECIFICATIONS

All properties are valid for the standard version of the Louvre, unless otherwise stated.

Weatherability		[EN 13030]
Class [details see p. 12]		A2 [0 m/s]
Airflow		[EN 13030]
K-factor [entry]		10.89
K-factor [discharge]		10.41
C _e coefficient		0.303
C _d coefficient		0.310
Technical data		
Visual free area		76%
Physical free area		53%

TECHNICAL DRAWINGS

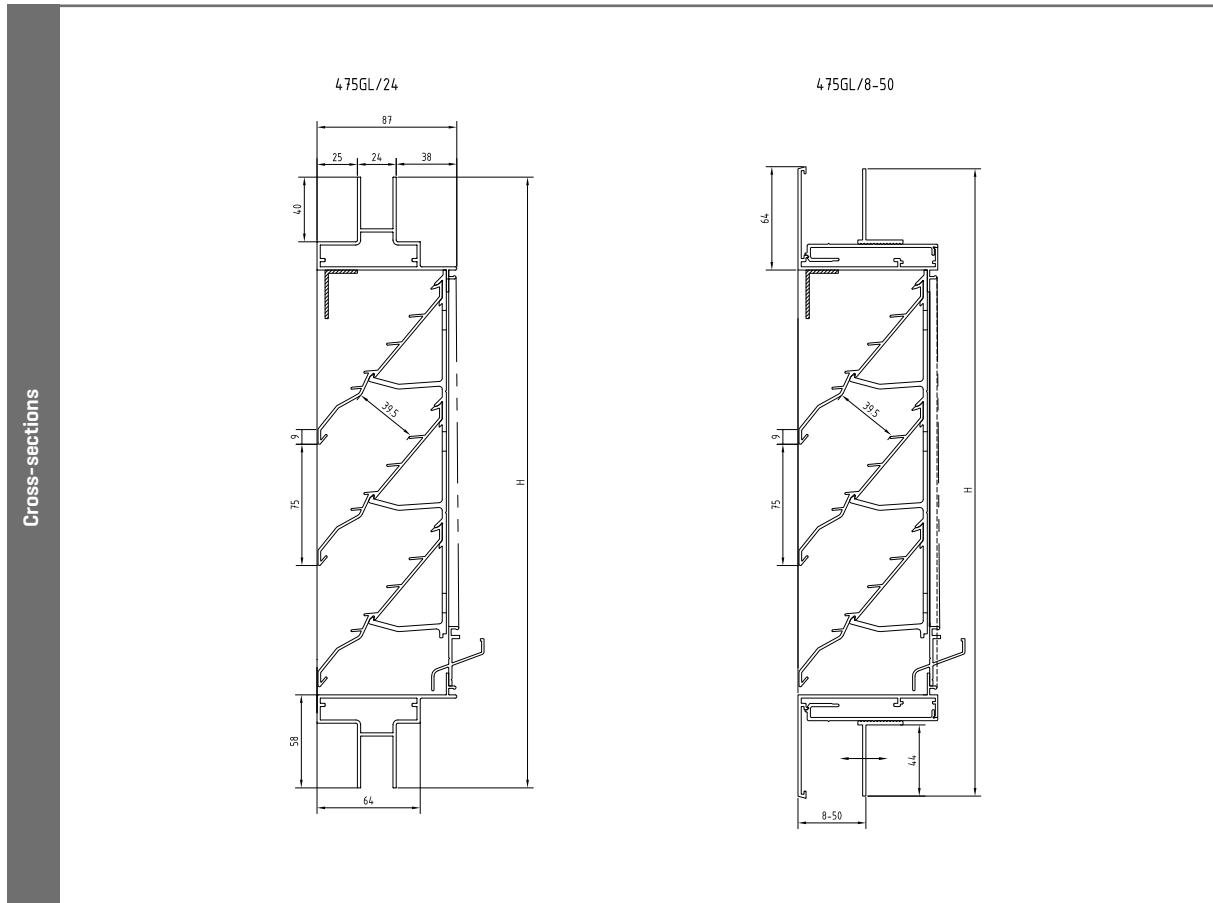

491

'Storm' wall louvre

WATER-
RESISTANT
LOUVRE

ALUMINIUM



MATERIAL

- Made from aluminium sections: AlMgSi 0.5 [according to EN 12020-2]
- Stainless steel 304 mesh [6 x 6 mm]
- Finishing: anodized in satin colour [20 micron] or powder-coated in any RAL or Syntha Pulvin colour [40 micron]

DIMENSIONS

- Blade pitch: 33 mm
- Depth to fit: 29 mm
- Flange size: 21 mm
- Minimum dimensions: 100 x 100 mm

FIXING

- Brackets ref. 418
- Spring clips ref. 419 available on request [small dimensions]

OPTIONS

- Stainless steel 304 mesh [2,3x2,3/10x10/20x20 mm] or without
- Water channel
- Drainage profile
- Insect screen or mesh in stainless steel 316
- Removable mesh
- Filter
- Without flange
- Welded blades on frame [only RAL finish]
- Glazed-in storm louvre 494 [see p. 102]

TYPICAL APPLICATIONS

- Good weatherability combined with low airflow, applications with a lot of wind, coastal area
- Snow resistant



TECHNICAL SPECIFICATIONS

All properties are valid for the standard version of the Louvre, unless otherwise stated.

Weatherability		[EN 13030]
Class for version with mesh 6x6 mm and water channel <i>[details see p. 12]</i>		A4 [0.5 m/s]
Airflow		[EN 13030]
K-factor [entry]		123.5
K-factor [discharge]		118.1
C _e coefficient		0.090
C _d coefficient		0.092
Technical data		
Visual free area		57%
Physical free area		26%
IP class		IP2XD
IP class for version with mesh 2.3x2.3 mm and water channel (electrical installation at least 150 mm)		IP44

AIR FLOW

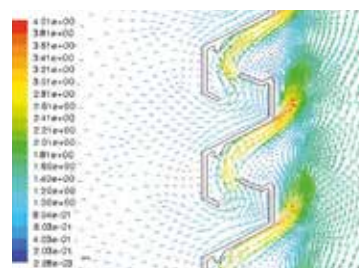

Supply

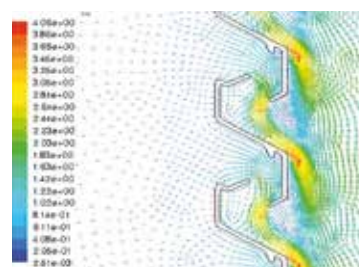

Extraction

TECHNICAL DRAWINGS

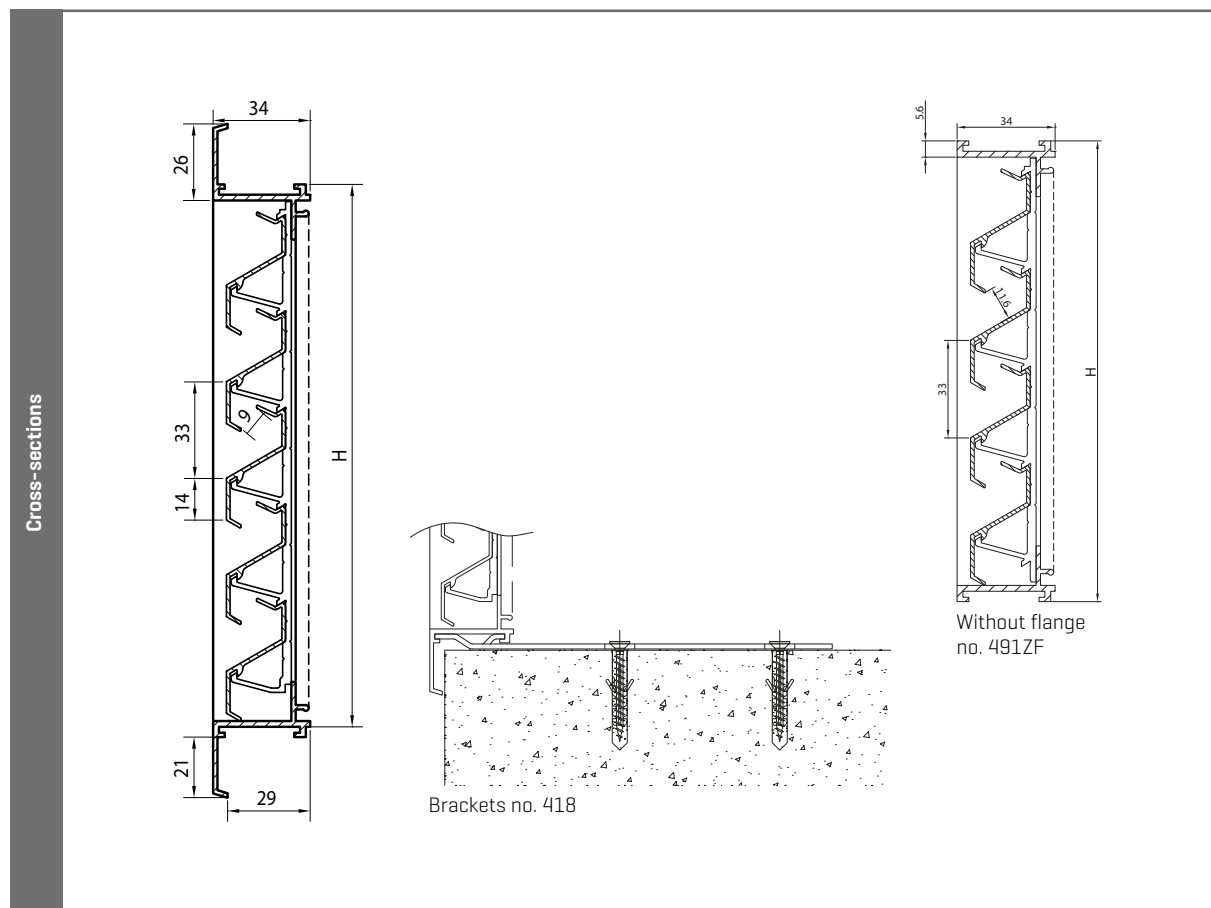

431

Surface-mounted wall louvre

SURFACE-MOUNTED LOUVRE

ALUMINIUM



MATERIAL

- Made from aluminium sections: AlMgSi 0.5 [according to EN 12020-2]
- Stainless steel 304 insect screen [2.3 x 2.3 mm]
- Finishing: anodized in satin colour [20 micron] or powder-coated in any RAL or Syntha Pulvin colour [40 micron]

DIMENSIONS

- Blade pitch: 33 mm
- Thickness: 29 mm
- Minimum dimensions: 120 x 120 mm

FIXING

- Screws and plugs are included
- Louvre 432 is the removable version of louvre 431 [see p. 76]

OPTIONS

- Stainless steel 304 mesh [6x6/10x10/20x20 mm] or without
- Burglar resistance louvre 431RC2 [see p. 122]
- Insect screen or mesh in stainless steel 316

TYPICAL APPLICATIONS

- Fixed louvre
- Nightcooling
- Standard surface-mounted louvre

STOCK MODELS

Dimensions (W x H) mm	Natural colour anodised	Renson Standard WHITE	STR 7016	STR 9005	Airflow at 2 Pa (m³/h)
165 x 165	00431111	00431116	00431113	00431119	23
225 x 225	00043122	00431226	00431223	00431229	50
325 x 325	00043133	00431336			118
425 x 425	00043144				215
525 x 525	00043155				342

TECHNICAL SPECIFICATIONS

All properties are valid for the standard version of the Louvre, unless otherwise stated.

Airflow		[EN 13030]
K-factor [entry]		20.47
K-factor [discharge]		19.58
C _e coefficient		0.221
C _d coefficient		0.226
Technical data		
Visual free area		59%
Physical free area		50%
IP class [louvre with mesh; electrical installation at least 100 mm from louvre]		IP2XD



Ventilated cooling

TECHNICAL DRAWINGS

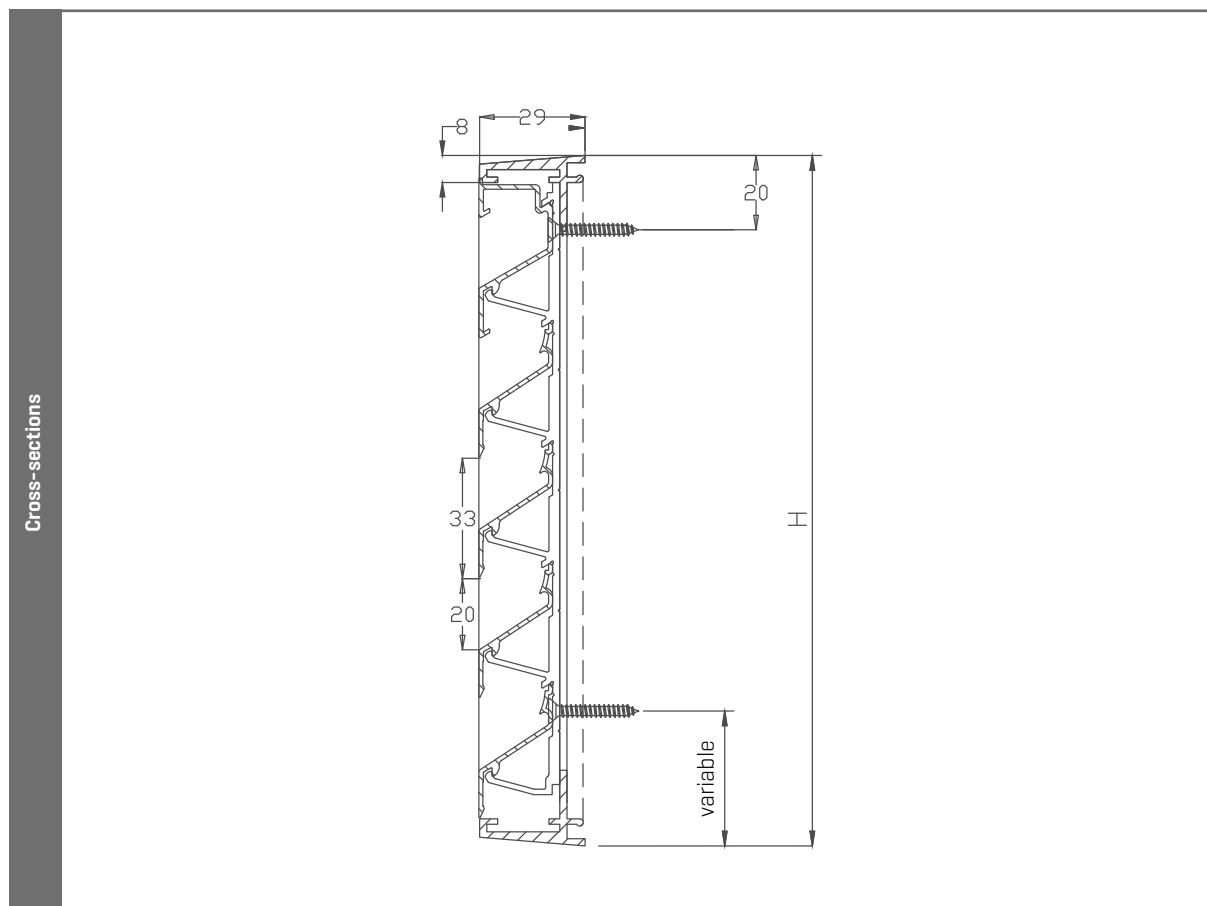

431R

Round louvre without frame

SURFACE-MOUNTED LOUVRE

ALUMINIUM

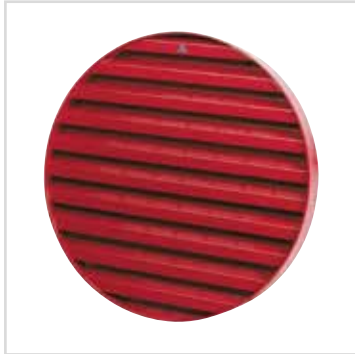

MATERIAL

- Made from aluminium sections: AlMgSi 0.5 [according to EN 12020-2]
- Stainless steel 304 insect screen [2.3 x 2.3 mm]
- Finishing: anodized in satin colour [20 micron] or powder-coated in any RAL or Syntha Pulvin colour [40 micron]

DIMENSIONS

- Blade pitch: 33,3 mm
- Depth to fit: 40 mm
- Minimum diameter: 300 mm
- Maximum diameter:
 - 1400 mm if anodised in satin colour
 - 1500 mm if powder-coated in RAL or Syntha Pulvin colour
 - Over 1500 mm: in two parts

FIXING

- Screws included

OPTIONS

- Stainless steel 304 mesh [6x6/10x10/20x20 mm] or without
- Insect screen or mesh in stainless steel 316

TECHNICAL SPECIFICATIONS

All properties are valid for the standard version of the Louvre, unless otherwise stated.

Airflow		[EN 13030]
K-factor [entry]		23.56
K-factor [discharge]		25.51
C _e coefficient		0.206
C _d coefficient		0.198
Technical data		
Visual free area		59%
Physical free area		40.5%
IP class [louvre with mesh; electrical installation at least 100 mm from louvre]		IP2XD

TECHNICAL DRAWINGS

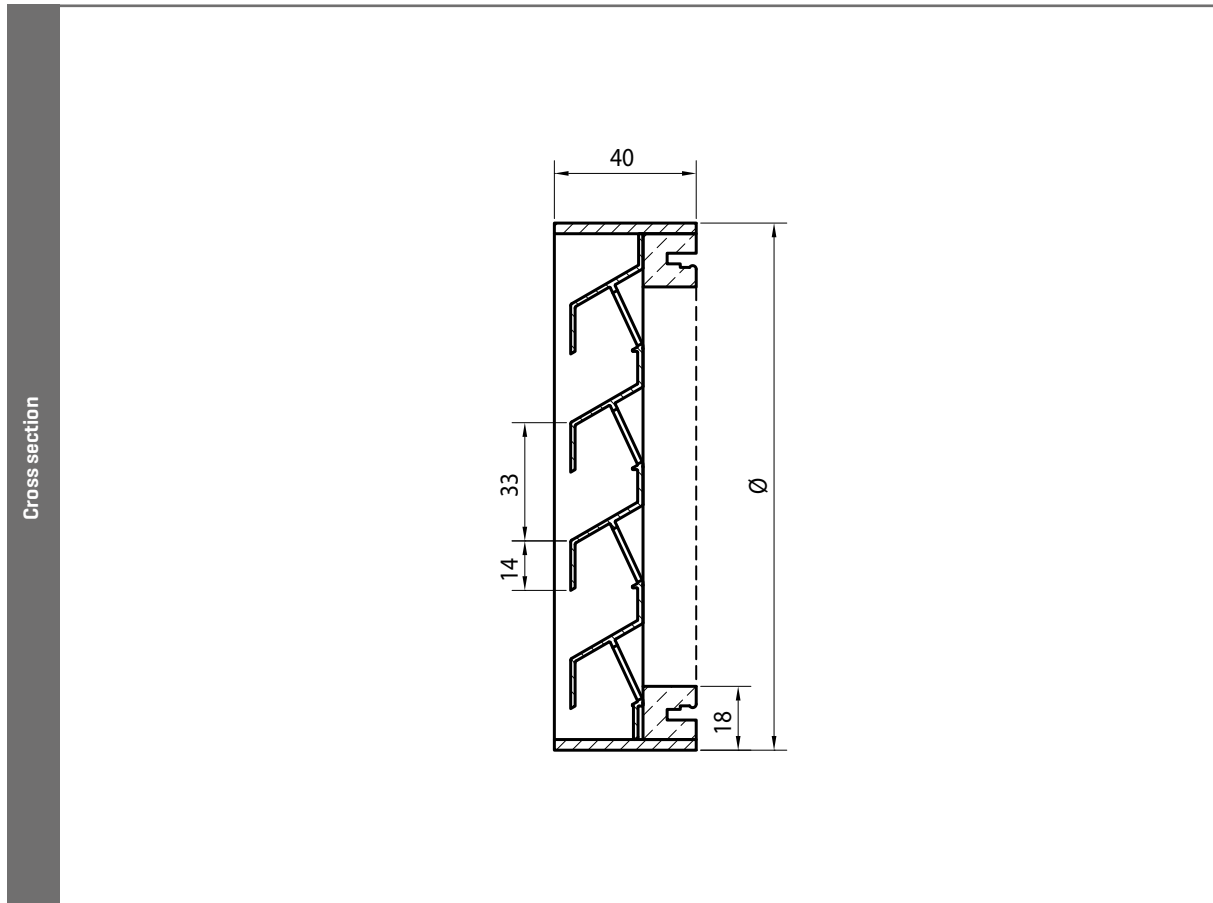

432

Surface-mounted, removable louvre with frame

SURFACE-MOUNTED LOUVRE

ALUMINIUM



MATERIAL

- Made from aluminium sections: AlMgSi 0.5 (according to EN 12020-2)
- Stainless steel 304 insect screen (2.3 x 2.3 mm)
- Finishing: anodized in satin colour (20 micron) or powder-coated in any RAL or Syntha Pulvin colour (40 micron)
- Consists of a screwfixed frame and a removable louvre

DIMENSIONS

- Blade pitch: 33 mm
- Thickness: 40 mm
- Minimum dimensions: 150 x 150 mm
- Maximum surface: 2.25 m²

FIXING

- Screws and plugs are included

OPTIONS

- Stainless steel 304 mesh (6x6/10x10/20x20 mm) or without
- Insect screen or mesh in stainless steel 316

TYPICAL APPLICATIONS

- Nightcooling
- Removable louvre: to enhance interior light levels and facilitate maintenance



TECHNICAL SPECIFICATIONS

All properties are valid for the standard version of the Louvre, unless otherwise stated.

Airflow		[EN 13030]
K-factor [entry]		20.47
K-factor [discharge]		19.58
C _e coefficient		0.221
C _d coefficient		0.226
Technical data		
Visual free area		59%
Physical free area		50%



TECHNICAL DRAWINGS

Cross-sections

The screwfixed frame is surface mounted. The removable louvre is installed from the outside and secured from the inside out by means of deadbolts. By unlocking these deadbolts the louvre can easily be removed.

433/S - 433/L

Surface-mounted louvres Pressure-relief damper

SURFACE-
MOUNTED
LOUVRE

ALUMINIUM



MATERIAL

- Made from aluminium sections: AlMgSi 0.5 [according to EN 12020-2]
- Finishing: anodized in satin colour [20 micron] or powder-coated in any RAL or Syntha Pulvin colour [40 micron]
- Extractor hood louvres: the blades open at the same time
- Pressure-relief louvres: the blades open individually
- Standard: without insect screen
- Opening pressure: 10 Pa standard, 20 Pa with enhanced blade

DIMENSIONS PRESSURE-RELIEF DAMPER 433/L

- Height: [multiple of 100] + 328 mm
- Minimum dimensions: 300 x 328 mm
- Thickness: 29 mm
- In length, the blades are in one piece up to 800 mm

DIMENSIONS EXTRACTOR HOOD LOUVRE 433/S

- See stock models

FIXING

- Invisible fixing
- Screws and plugs are included

OPTIONS

- Stainless steel 304 mesh [6x6/10x10/20x20 mm] or without
- Insect screen or mesh in stainless steel 316

TYPICAL APPLICATIONS

- Extractor hood
- Drying cabinet

STOCK MODELS

Dimensions (W x H) mm	Natural colour anodised	Renson Standard WHITE	RAL 8019	STR 7016	STR 9005
Extractor hood louvres 433/S					
173 x 173	04331731	04331736		04331733	04331739
210 x 210	04332101	04332106		04332103	04332109
246 x 246	04332461	04332466	04332467		
Pressure-relief dampers 433/L					
328 x 328	00433328				
428 x 428	00433428				
528 x 528	00433528				

TECHNICAL DRAWINGS

Renson® Technology extractor hood louvre 433/S

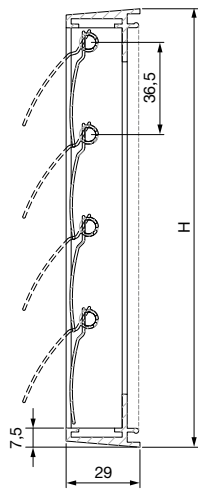

Pressure-relief damper 433/L

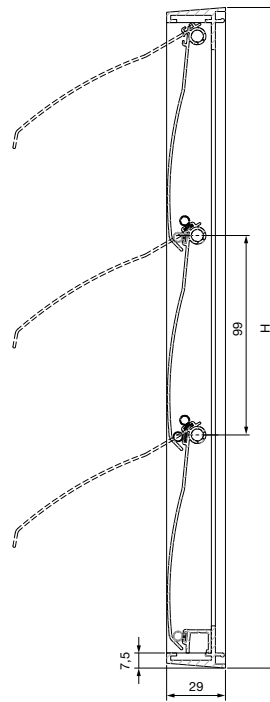

414

Glazed-in louvre

GLAZED-IN
LOUVRE

ALUMINIUM



MATERIAL

- Made from aluminium sections: AlMgSi 0.5 [according to EN 12020-2]
- Stainless steel 304 insect screen [2.3 x 2.3 mm]
- Finishing: anodized in satin colour [20 micron] or powder-coated in any RAL or Syntha Pulvin colour [40 micron]

DIMENSIONS

- Blade pitch: 33,3 mm
- Frame thickness: 24, 28 or 32 mm
- Minimum dimensions: 130 x 130 mm
- Specify on ordering: width x height in mm [overall dimensions]

FIXING

- Suitable for 24, 28, 32 mm glazing sections. Other thicknesses on request.

OPTIONS

- Stainless steel 304 mesh [6x6/10x10/20x20 mm] or without
- Drainage profile
- Insect screen or mesh in stainless steel 316
- Water channel
- Removable mesh
- Filter
- Pressure-relief louvre

TYPICAL APPLICATIONS

- Nightcooling



TECHNICAL SPECIFICATIONS

All properties are valid for the standard version of the Louvre, unless otherwise stated.

Weatherability		[EN 13030]
Class [details see p. 12]		A3 [0.5 m/s]
Airflow		[EN 13030]
K-factor [entry]		20.47
K-factor [discharge]		19.58
C _e coefficient		0.221
C _d coefficient		0.226
Technical data		
Visual free area		59%
Physical free area		50%
IP class [louvre with mesh; electrical installation at least 100 mm from louvre]		IP2XD



TECHNICAL DRAWINGS

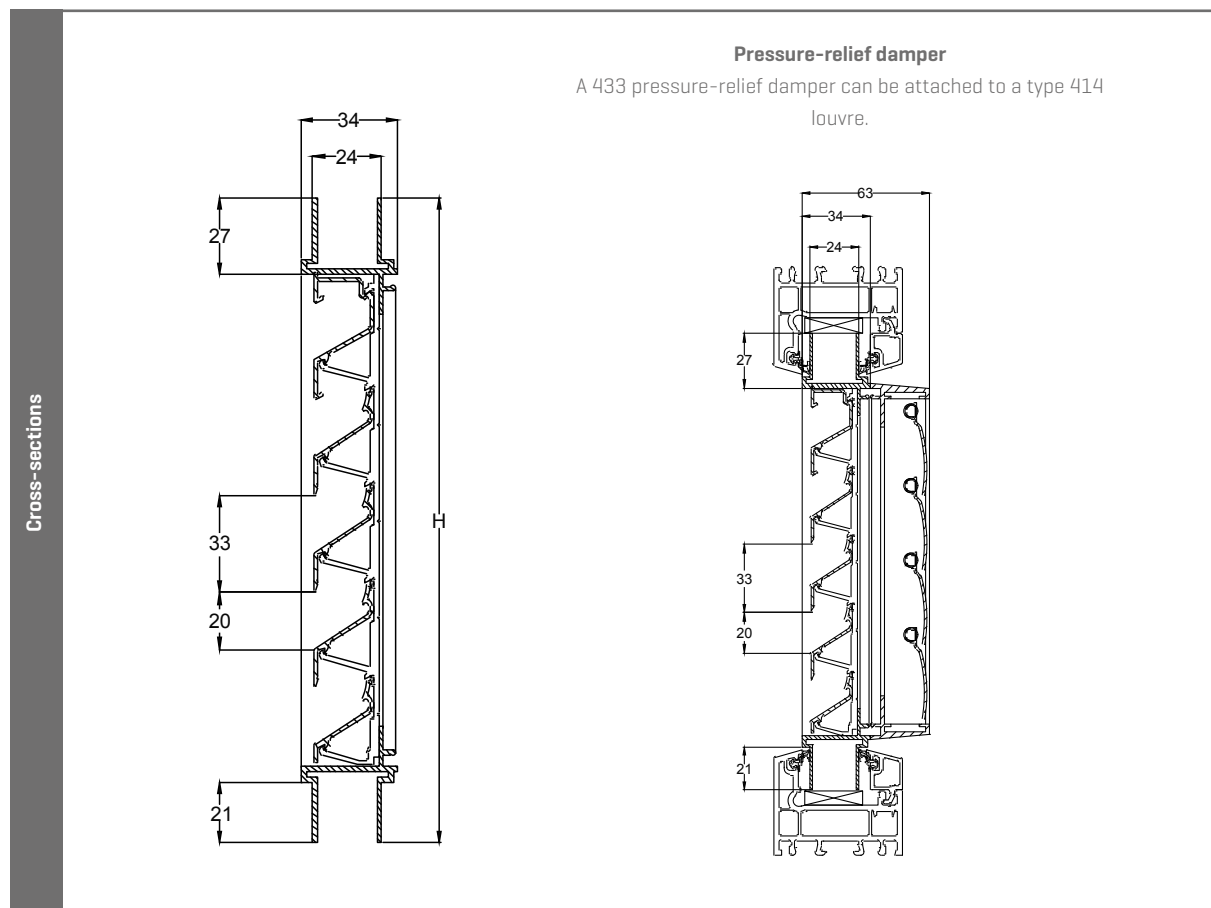

414R

Round glazed-in louvre

GLAZED-IN
LOUVRE

ALUMINIUM

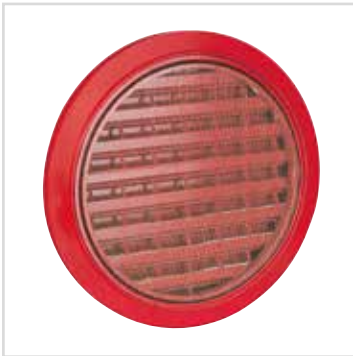

MATERIAL

- Made from aluminium sections: AlMgSi 0.5 [according to EN 12020-2]
- Stainless steel 304 insect screen [2.3 x 2.3 mm]
- Finishing: anodized in satin colour [20 micron] or powder-coated in any RAL or Syntha Pulvin colour [40 micron]

DIMENSIONS

- Blade pitch: 33,3 mm
- Frame thickness: 24 mm
- Minimum diameter: 340 mm
- Maximum diameter:
 - 1400 mm if anodised in satin colour
 - 1500 mm if powder-coated in RAL or Syntha Pulvin colour
 - Over 1500 mm: in two parts

FIXING

- Suitable for 24, 28, 32 mm glazing sections. Other thicknesses on request.

OPTIONS

- Stainless steel 304 mesh [6x6/10x10/20x20 mm] or without
- Insect screen or mesh in stainless steel 316

TECHNICAL SPECIFICATIONS

All properties are valid for the standard version of the Louvre, unless otherwise stated.

Airflow		[EN 13030]
K-factor [entry]		23.56
K-factor [discharge]		25.51
C _e coefficient		0.206
C _d coefficient		0.198
Technical data		
Visual free area		59%
Physical free area		40.5%
IP class [louvre with mesh; electrical installation at least 100 mm from louvre]		IP2XD

TECHNICAL DRAWINGS

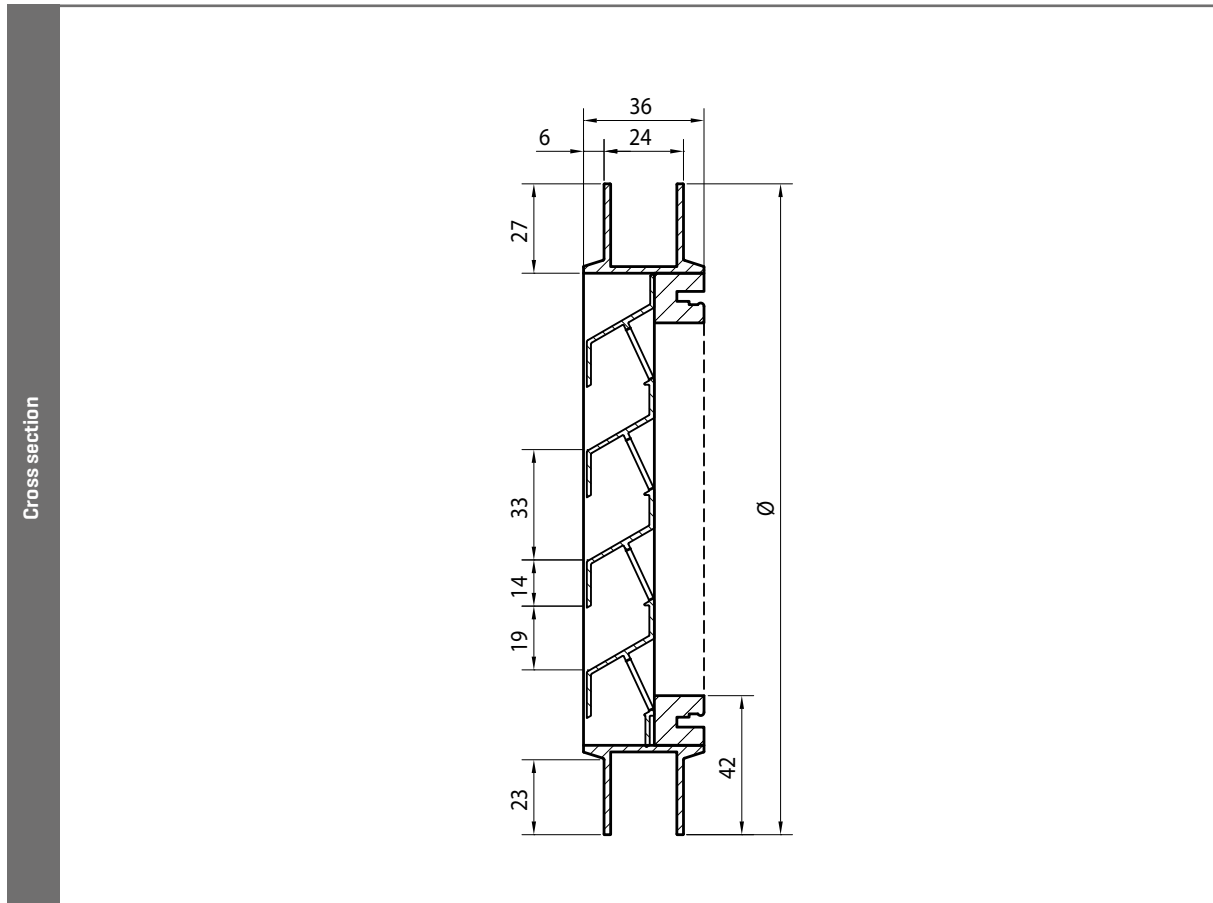

414VA

Controllable louvre

GLAZED-IN
LOUVRE

ALUMINIUM



414VA



414/D

MATERIAL

- Made from aluminium sections: AlMgSi 0.5 [according to EN 12020-2]
- Stainless steel 304 mesh [2.3 x 2.3 mm]
- Finishing: anodized in satin colour [20 micron] or powder-coated in any RAL or Syntha Pulvin colour [40 micron]

DIMENSIONS

- Blade pitch: 33,3 mm
- Frame thickness: 24, 28 or 32 mm
- Minimum dimensions: 200 x 130 mm
- Specify on ordering: width x height in mm [overall dimensions]
- Controllable in combination with 100, 130 and 150 mm hit-and-miss ventilators or with insulated aluminium door [414/D] [max size 400 x 400 mm]

FIXING

- Suitable for 24, 28, 32 mm glazing sections. Other thicknesses on request.

OPTIONS

- Stainless steel 304 mesh [6x6/10x10/20x20 mm] or without
- Insect screen or mesh in stainless steel 316

CONTROL OPTIONS (1 CONTROL PANEL PER MODULE)

- Knob control [standard]
- Rod
- Cord
- Motor

TECHNICAL SPECIFICATIONS

All properties are valid for the standard version of the Louvre, unless otherwise stated.

Airflow		[EN 13030]
K-factor [entry]		28.13
C _e coefficient		0.189

[For combinations with closable louvres 130 and 150 mm]



TECHNICAL DRAWINGS

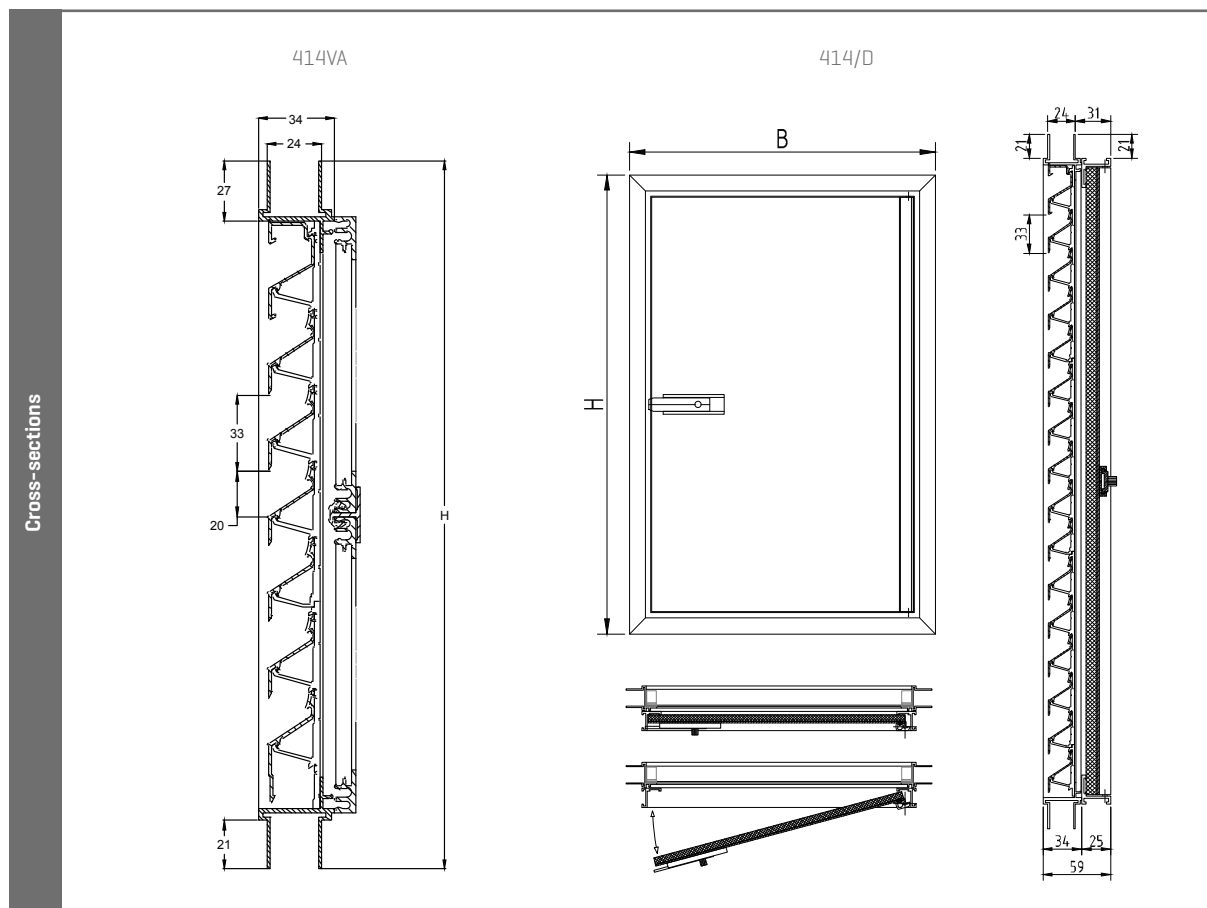

414THF

Thermally insulated window louvre

GLAZED-IN
LOUVRE

ALUMINIUM

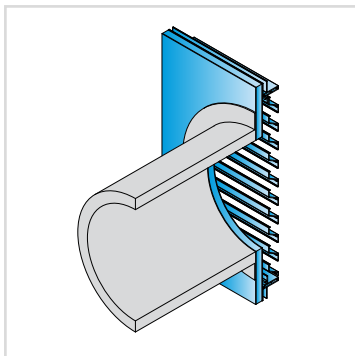
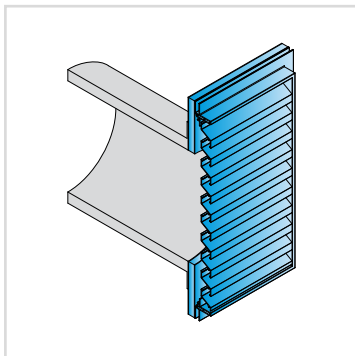

MATERIAL

- Made from aluminium sections: AlMgSi 0.5 [according to EN 12020-2]
- Finishing: anodized in satin colour [20 micron] or powder-coated in any RAL or Syntha Pulvin colour [40 micron]
- Thermal insulation panel with PUR foam composite
- Sandwich panel can also be powdercoated on both sides

DIMENSIONS

- Blade pitch: 33,3 mm
- Minimum size: 130 x 130 mm
- Frame thickness: 24, 28, or 32 mm
- Specify on ordering: width x height in mm [overall dimensions]

FIXING

- Suitable for 24, 28, 32 mm glazing sections. Other thicknesses on request.

TYPICAL APPLICATIONS

- Curtain walls
- Thermally insulated air duct

TECHNICAL SPECIFICATIONS

All properties are valid for the standard version of the Louvre, unless otherwise stated.

[for cut-out part of thermal insulation]

Airflow		[EN 13030]
K-factor [entry]		20.47
K-factor [discharge]		19.58
C _e coefficient		0.221
C _d coefficient		0.226
Technical data		
Visual free area		59 %
Physical free area		50 %
U-value 1,1 W/m ² K		1,1 W/m ² K
IP class		IP2XD

TECHNICAL DRAWINGS

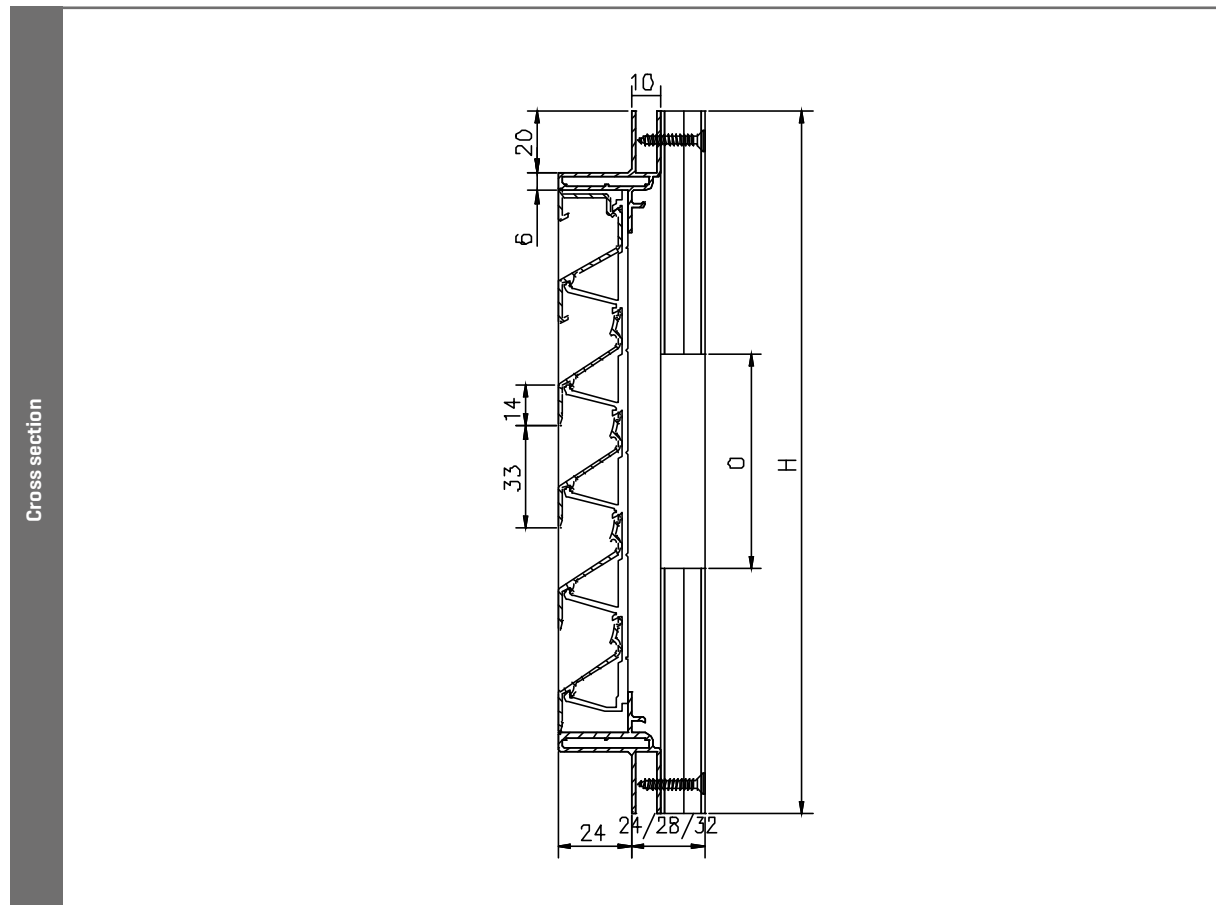

415

Glazed-in louvre with chevron section blades

GLAZED-IN
LOUVRE

ALUMINIUM



MATERIAL

- Made from aluminium sections: AlMgSi 0.5 [according to EN 12020-2]
- Stainless steel 304 mesh [6 x 6 mm]
- Finishing: anodized in satin colour [20 micron] or powder-coated in any RAL or Syntha Pulvin colour [40 micron]

DIMENSIONS

- Blade pitch: 20 mm
- Frame thickness: 24, 28 or 32 mm
- Minimum dimensions: 130 x 130 mm
- Specify on ordering: width x height in mm [Overall dimensions]

FIXING

- Suitable for 24, 28, 32 mm glazing sections. Other thicknesses on request.

OPTIONS

- Stainless steel 304 insect screen 2,3x2,3 or mesh [10x10/20x20 mm] or without
- Insect screen or mesh in stainless steel 316
- Water channel
- Drainage profile
- Removable mesh
- Filter

TYPICAL APPLICATIONS

- Window Louvre with no look-through and stick-proof



TECHNICAL SPECIFICATIONS

All properties are valid for the standard version of the Louvre, unless otherwise stated.

Weatherability		[EN 13030]
Class for execution with mesh 2.3x2.3 mm and water channel (details see p. 12)		A4 [1 m/s]
Airflow		[EN 13030]
K-factor [entry]		34.60
K-factor [discharge]		34.60
C _e coefficient		0.170
C _d coefficient		0.170
Technical data		
Visual free area		93%
Physical free area		39%
IP class		IP2XD
IP class for version with mesh 2.3x2.3 mm and water channel (electrical installation at least 350 mm)		IP44



TECHNICAL DRAWINGS

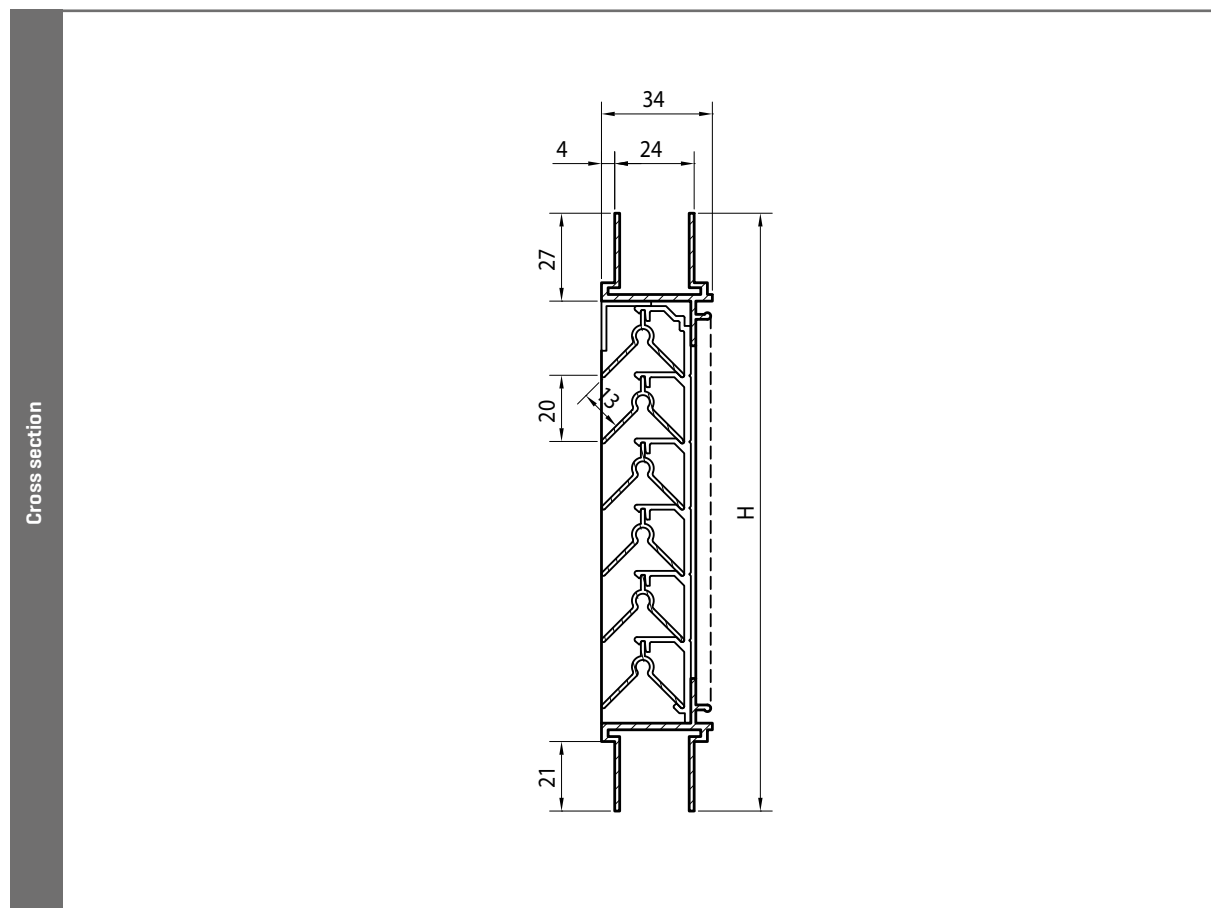

415R

Round louvre with chevron section blades

GLAZED-IN
LOUVRE

ALUMINIUM

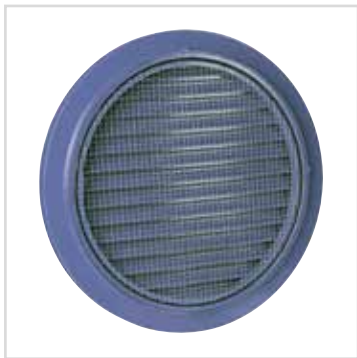
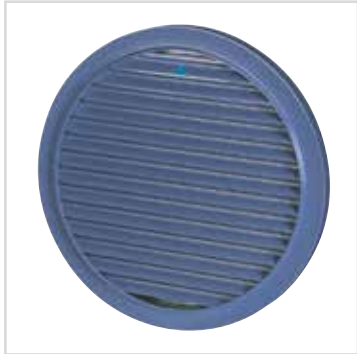

MATERIAL

- Made from aluminium sections: AlMgSi 0.5 (according to EN 12020-2)
- Stainless steel 304 mesh [6 x 6 mm]
- Finishing: anodized in satin colour [20 micron] or powder-coated in any RAL or Syntha Pulvin colour [40 micron]
- Frame assembled by a single weld

DIMENSIONS

- Blade pitch: 20 mm
- Frame thickness: 24 mm
- Minimum diameter: 340 mm
- Maximum diameter:
 - 1400 mm if anodised in satin colour
 - 1500 mm if powder-coated in RAL or Syntha Pulvin colour
 - Over 1500 mm: in two parts

FIXING

- To be fitted like double glazing

OPTIONS

- Stainless steel 304 mesh [2,3x2,3/10x10/20x20 mm] or without
- Insect screen or mesh in stainless steel 316



TECHNICAL SPECIFICATIONS

All properties are valid for the standard version of the Louvre, unless otherwise stated.

Airflow		[EN 13030]
K-factor [entry]		34.60
K-factor [discharge]		34.60
C _e coefficient		0.170
C _d coefficient		0.170
Technical data		
Visual free area		93%
Physical free area		39%
IP class		IP2XD

TECHNICAL DRAWINGS

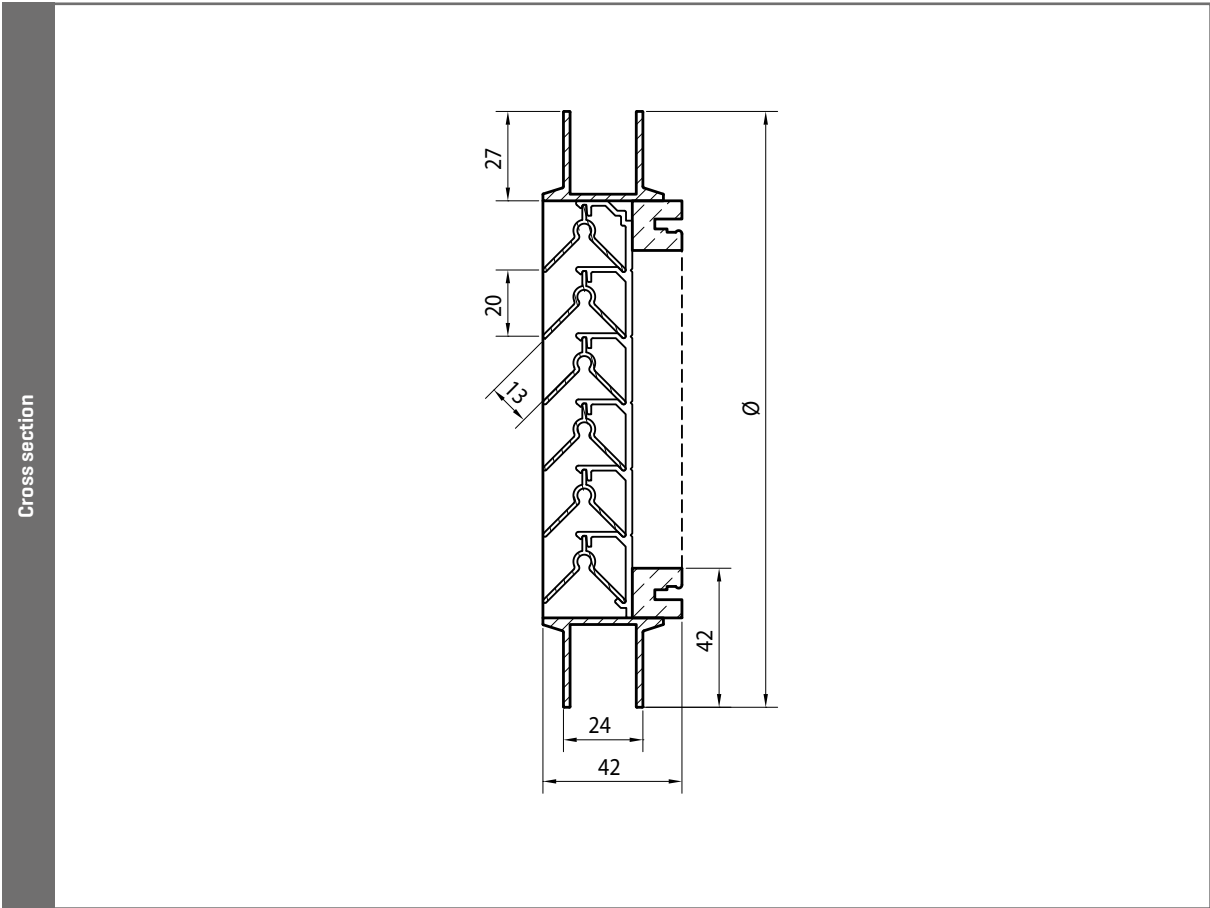

Cross section

415VA

Controllable louvre with chevron section blades

GLAZED-IN
LOUVRE

ALUMINIUM



MATERIAL

- Made from aluminium sections: AlMgSi 0.5 [according to EN 12020-2]
- Stainless steel 304 mesh [6 x 6 mm]
- Finishing: anodized in satin colour [20 micron] or powder-coated in any RAL or Syntha Pulvin colour [40 micron]

DIMENSIONS

- Blade pitch: 20 mm
- Frame thickness: 24, 28 or 32 mm
- Specify on ordering: width x height in mm [overall dimensions]
- Controllable in combination with 100, 130 and 150 mm hit-and-miss ventilators or with insulated aluminium door [415/D]
- Minimum dimensions: 200 x 130 mm

FIXING

- Suitable for 24, 28, 32 mm glazing sections. Other thicknesses on request.

OPTIONS

- Stainless steel 304 mesh [2,3x2,3/10x10/20x20 mm] or without
- Insect screen or mesh in stainless steel 316

CONTROLOPTIONS [1 CONTROLPANEL PER MODULE]

- Standard: knob control
- Rod
- Cord
- Motor

TYPICAL APPLICATIONS

- Classrooms



TECHNICAL SPECIFICATIONS

All properties are valid for the standard version of the Louvre, unless otherwise stated.

Airflow		(EN 13030)
K-factor [entry]		34.24
C _e coefficient		0.171
<i>[For combinations with closable louvres 130 and 150 mm]</i>		
Technical data		
IP class		IP2XD



TECHNICAL DRAWINGS

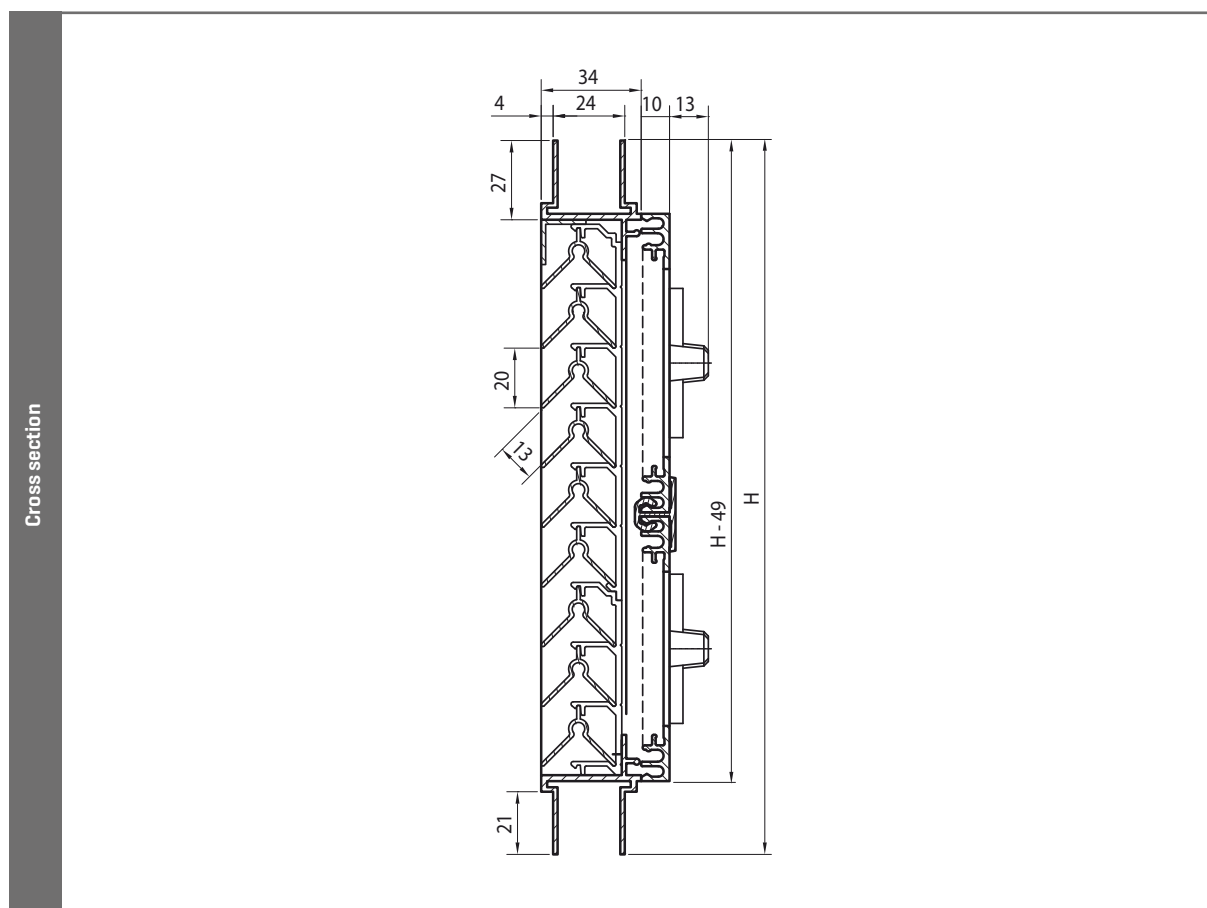

424

Glazed-in louvre, heavy-duty series

GLAZED-IN
LOUVRE

ALUMINIUM



MATERIAL

- Made from aluminium sections: AlMgSi 0.5 [according to EN 12020-2]
- Stainless steel 304 insect screen [2.3 x 2.3 mm]
- Finishing: anodized in satin colour [20 micron] or powder-coated in any RAL or Syntha Pulvin colour [40 micron]

DIMENSIONS

- Blade pitch: 50 mm
- Frame thickness: 24 or 28 mm
- Specify on ordering: full width x height in mm
- Minimum dimensions: 220 x 220 mm

FIXING

- Suitable for 24 and 28 mm glazing sections. Other thicknesses on request.

OPTIONS

- Stainless steel 304 mesh [6x6/10x10/20x20 mm] or without
- Insect screen or mesh in stainless steel 316
- Water channel
- Drainage profile
- Removable mesh
- Filter

TECHNICAL SPECIFICATIONS

All properties are valid for the standard version of the Louvre, unless otherwise stated.

Airflow		[EN 13030]
K-factor [entry]		13.42
K-factor [discharge]		11.73
C _e coefficient		0.273
C _d coefficient		0.292
Technical data		
Visual free area		70%
Physical free area		49%
IP class [louvre with mesh; electrical installation at 105 mm at least]		IP2XD



TECHNICAL DRAWINGS

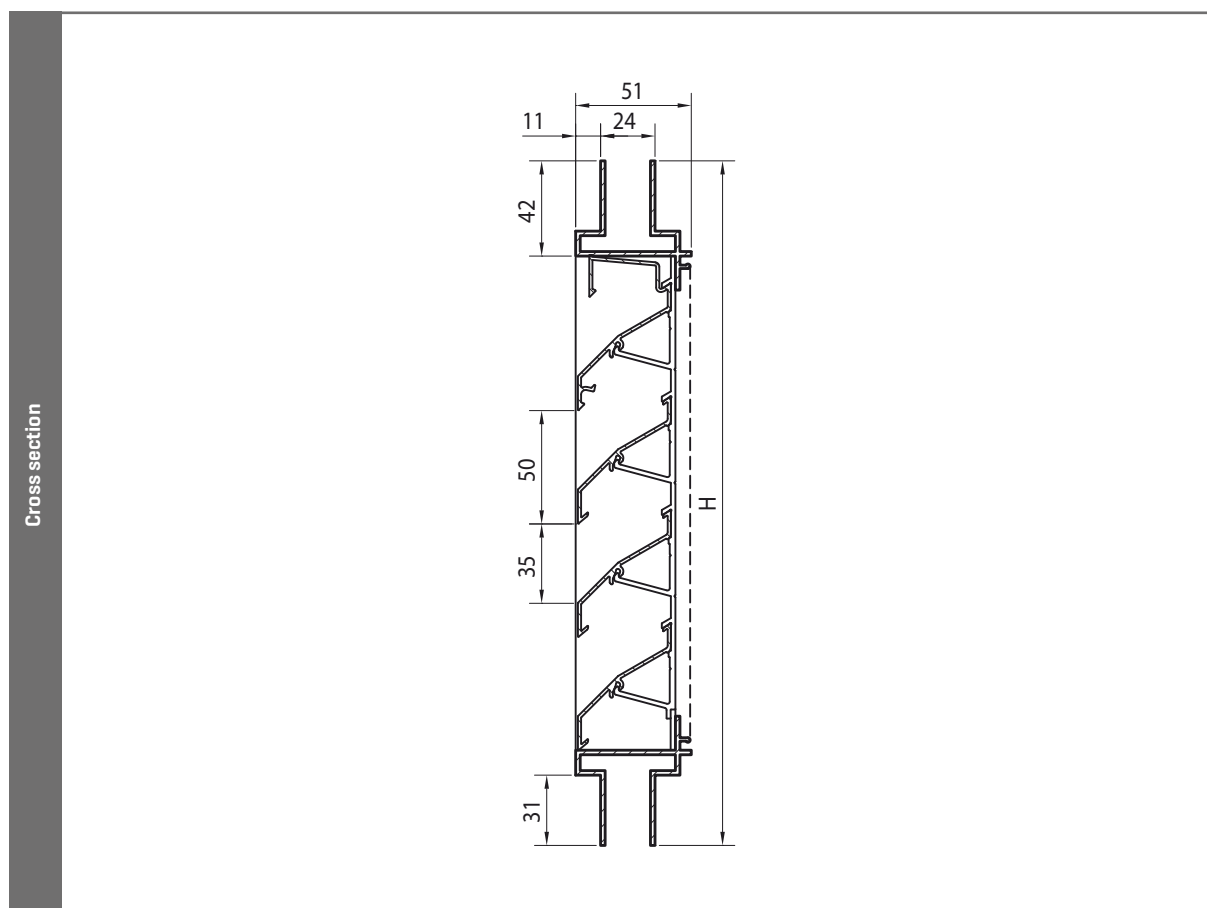

428

AVAILABLE UNTIL END OF STOCK

Glazed-in louvre with chevron section blades, heavy-duty series

GLAZED-IN
LOUVRE

ALUMINIUM



MATERIAL

- Made from aluminium sections: AlMgSi 0.5 [according to EN 12020-2]
- Standard stainless steel 304 insect screen [2.3 x 2.3 mm]
- Finishing: anodized in satin colour [20 micron] or powder-coated in any RAL or Syntha Pulvin colour [40 micron]

DIMENSIONS

- Blade pitch: 33,3 mm
- Frame thickness: 24 or 28 mm
- Specify on ordering: full width x height in mm
- Minimum dimensions: 220 x 220 mm

FIXING

- Suitable for 24 and 28 mm glazing sections. Other thicknesses on request.

OPTIONS

- Stainless steel 304 mesh [6x6/10x10/20x20 mm] or without
- Insect screen or mesh in stainless steel 316
- Water channel
- Drainage profile
- Removable mesh
- Filter
- Controllable louvre 428/VA



TECHNICAL SPECIFICATIONS

All properties are valid for the standard version of the Louvre, unless otherwise stated.

Weatherability		[EN 13030]
Class for execution with mesh 6x6 mm and water channel <i>[details see p. 12]</i>		A4 [0.5 m/s]
Airflow		[EN 13030]
K-factor [entry]		66.10
K-factor [discharge]		66.10
C _e coefficient		0.123
C _d coefficient		0.123
Technical data		
Visual free area		59%
Physical free area		43%
IP class for execution with standard mesh 2.3x2.3 mm and water channel electrical installation at least 200mm]		IP44

TECHNICAL DRAWINGS

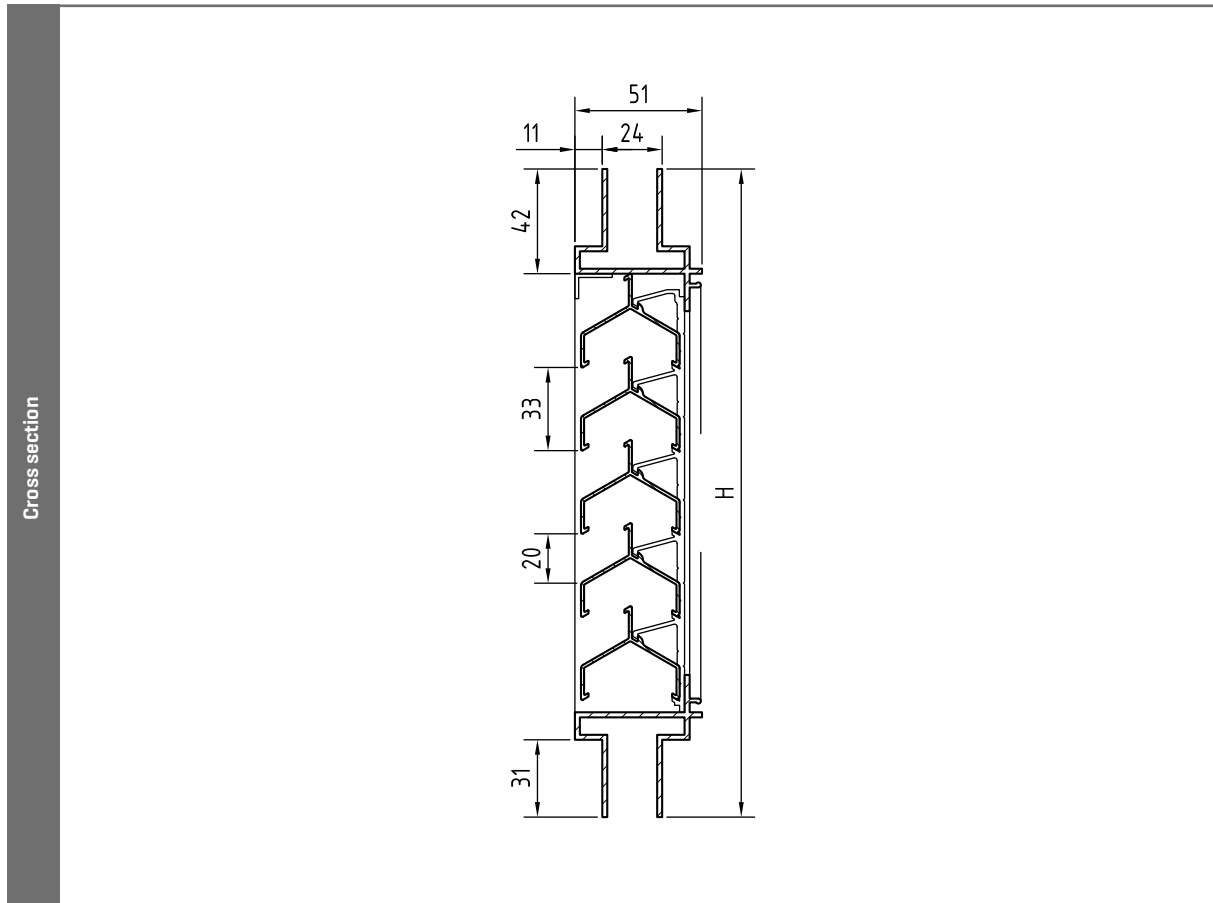

483

High-airflow glazed-in louvre

GLAZED-IN
LOUVRE

ALUMINIUM



MATERIAL

- Made from aluminium sections: AlMgSi 0.5 [according to EN 12020-2]
- Standard stainless steel 304 mesh [6 x 6 mm]
- Finishing: anodized in satin colour [20 micron] or powder-coated in any RAL or Syntha Pulvin colour [40 micron]

DIMENSIONS

- Blade pitch: 60 mm
- Frame thickness: 24 mm [frame thickness of 8 to 80 mm on request]
- Specify on ordering: full width x height in mm
- Minimum dimensions: 385 x 385 mm

FIXING

- Suitable for 24 and 28 mm glazing sections. Other thicknesses on request.

OPTIONS

- Stainless steel 304 insect screen 2,3x2,3 or mesh [10x10/20x20 mm] or without
- Insect screen or mesh in stainless steel 316
- Water channel
- Drainage profile
- Removable mesh
- Filter

TYPICAL APPLICATIONS

- Applications with request for high air-flow



TECHNICAL SPECIFICATIONS

All properties are valid for the standard version of the Louvre, unless otherwise stated.

Airflow		[EN 13030]
K-factor [entry]		4,60
K-factor [discharge]		5,17
C _e coefficient		0,466
C _d coefficient		0,440
Technical data		
Visual free area		90%
Physical free area		76%

TECHNICAL DRAWINGS

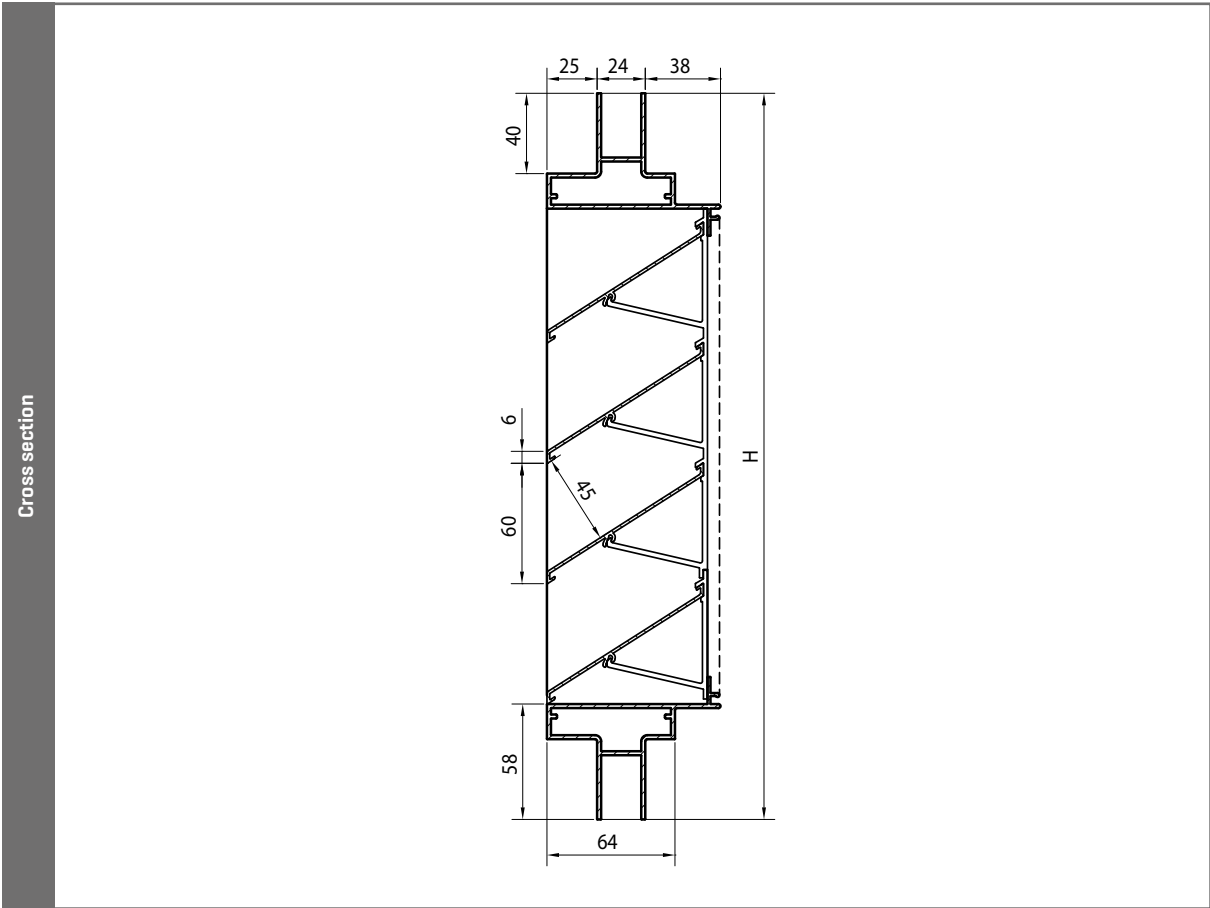

484

Glazed-in louvre, heavy-duty series

GLAZED-IN
LOUVRE

ALUMINIUM



MATERIAL

- Made from aluminium sections: AlMgSi 0.5 [according to EN 12020-2]
- Stainless steel 304 insect screen [2.3 x 2.3 mm]
- Finishing: anodized in satin colour [20 micron] or powder-coated in any RAL or Syntha Pulvin colour [40 micron]

DIMENSIONS

- Blade pitch: 50 mm
- Frame thickness: 24 or 28 mm
- Specify on ordering: full width x height in mm
- Minimum dimensions: 220 x 220 mm

FIXING

- Suitable for 24 and 28 mm glazing sections. Other thicknesses on request.

OPTIONS

- Stainless steel 304 insect screen 2,3x2,3 or mesh [10x10/20x20 mm] or without
- Insect screen or mesh in stainless steel 316
- Drainage profile
- Water channel
- Removable mesh
- Filter
- Controllable type 484/VA – same build as type 414/VA

TECHNICAL SPECIFICATIONS

All properties are valid for the standard version of the Louvre, unless otherwise stated.

Airflow		[EN 13030]
K-factor [entry]		9.59
K-factor [discharge]		10.01
C _e coefficient		0.323
C _d coefficient		0.316
Technical data		
Visual free area		70%
Physical free area		60%
IP class [louvre with mesh; electrical installation at least 100 mm from louvre]		IP2XD

TECHNICAL DRAWINGS

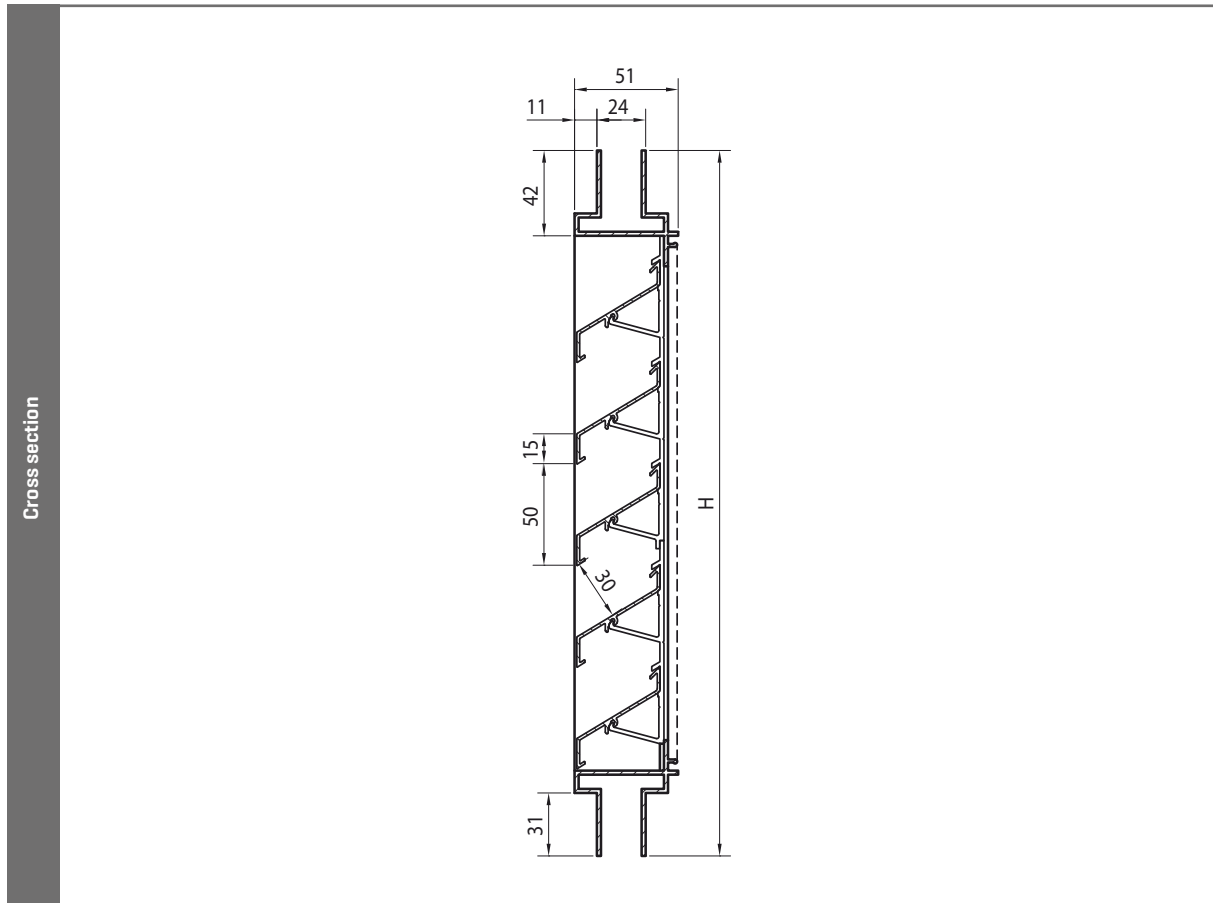

494

Glazed-in 'storm' louvre

GLAZED-IN
LOUVRE

ALUMINIUM



MATERIAL

- Made from aluminium sections: AlMgSi 0.5 [according to EN 12020-2]
- Stainless steel 304 mesh [6 x 6 mm]
- Finishing: anodized in satin colour [20 micron] or powder-coated in any RAL or Syntha Pulvin colour [40 micron]

DIMENSIONS

- Blade pitch: 33,3 mm
- Frame thickness: 24, 28 or 32 mm
- Specify on ordering: full width x height in mm
- Minimum dimensions: 130 x 130 mm

FIXING

- Suitable for 24, 28, 32 mm glazing sections. Other thicknesses on request.

OPTIONS

- Stainless steel 304 insect screen 2,3x2,3 or mesh [10x10/20x20 mm] or without
- Insect screen or mesh in stainless steel 316
- Water channel
- Drainage profile
- Removable mesh
- Filter
- Welded blades on frame [only RAL finish]



TECHNICAL SPECIFICATIONS

All properties are valid for the standard version of the Louvre, unless otherwise stated.

Weatherability		[EN 13030]
Class for version with mesh 6x6 mm and water channel [details see p. 12]		A4 [0.5 m/s]
Airflow		[EN 13030]
K-factor [entry]		123.5
K-factor [discharge]		118.1
C _e coefficient		0.090
C _d coefficient		0.092
Technical data		
Visual free area		57%
Physical free area		26%
IP class for version with mesh 2.3x2.3 mm and water channel [electrical installation on at least 150 mm]'		IP2XD

AIR FLOW

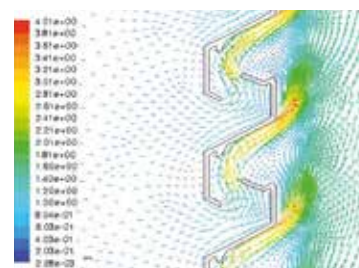

Supply

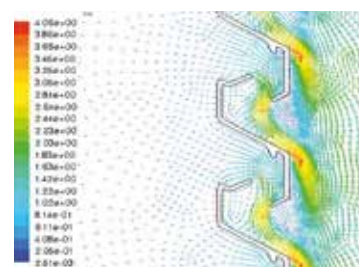

Extraction

TECHNICAL DRAWINGS

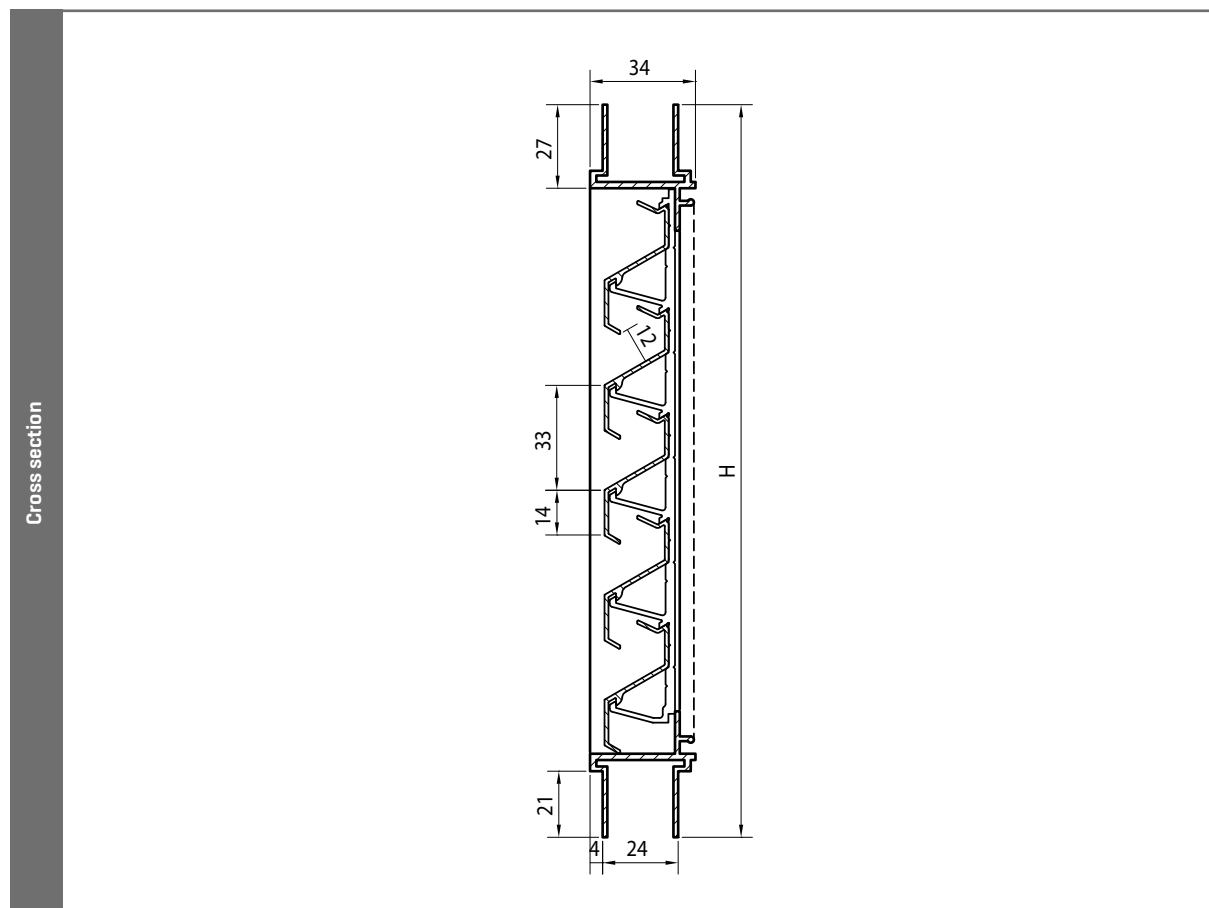

427GL

Glazed-in louvre with adjustable blades, extra-heavy-duty series

GLAZED-IN
LOUVRE

ALUMINIUM



MATERIAL

- Made from aluminium sections: AlMgSi 0.5 [according to EN 12020-2]
- Stainless steel 304 mesh [6 x 6 mm]
- Finishing: anodized in satin colour [20 micron] or powder-coated in any RAL or Syntha Pulvin colour [40 micron]

DIMENSIONS

- Blade pitch: 100 mm
- Maximum width in one piece: 1300 mm
- Frame thickness: 24 mm [frame thickness of 8 to 50 mm on request]
- Specify on ordering: full width x height in mm
- Minimum dimensions: 377 x 377 mm
- Preferred height = [multiple of x 100] + 377 mm

Remarque: the minimum height is dependant of the control option.

FIXING

- Suitable for 24 and 28 mm glazing sections. Other thicknesses on request.

OPTIONS

- Stainless steel 304 insect screen 2,3x2,3 or mesh [10x10/20x20 mm] or without
- Insect screen or mesh in stainless steel 316

CONTROL OPTIONS

- 427/1 Manual: min. height 377 mm
- 427/2 Cable: min. height 477 mm
- 427/3 Ultraflex: min. height 777 mm
- 427/4 Motor: [220V - 24V] / spring-return actuator [24V]: min. height 477 mm
- 427/5 Air pressure: min. height 477 mm

For more information on the different control modes, please refer to p. 38 and 39.

TECHNICAL SPECIFICATIONS

All properties are valid for the standard version of the Louvre, unless otherwise stated.

Airflow		[EN 13030]
K-factor [entry]		11.41
K-factor [discharge]		11.65
C _e coefficient		0.296
C _d coefficient		0.293
Technical data		
Visual free area		88%
Physical free area		53%

TECHNICAL DRAWINGS

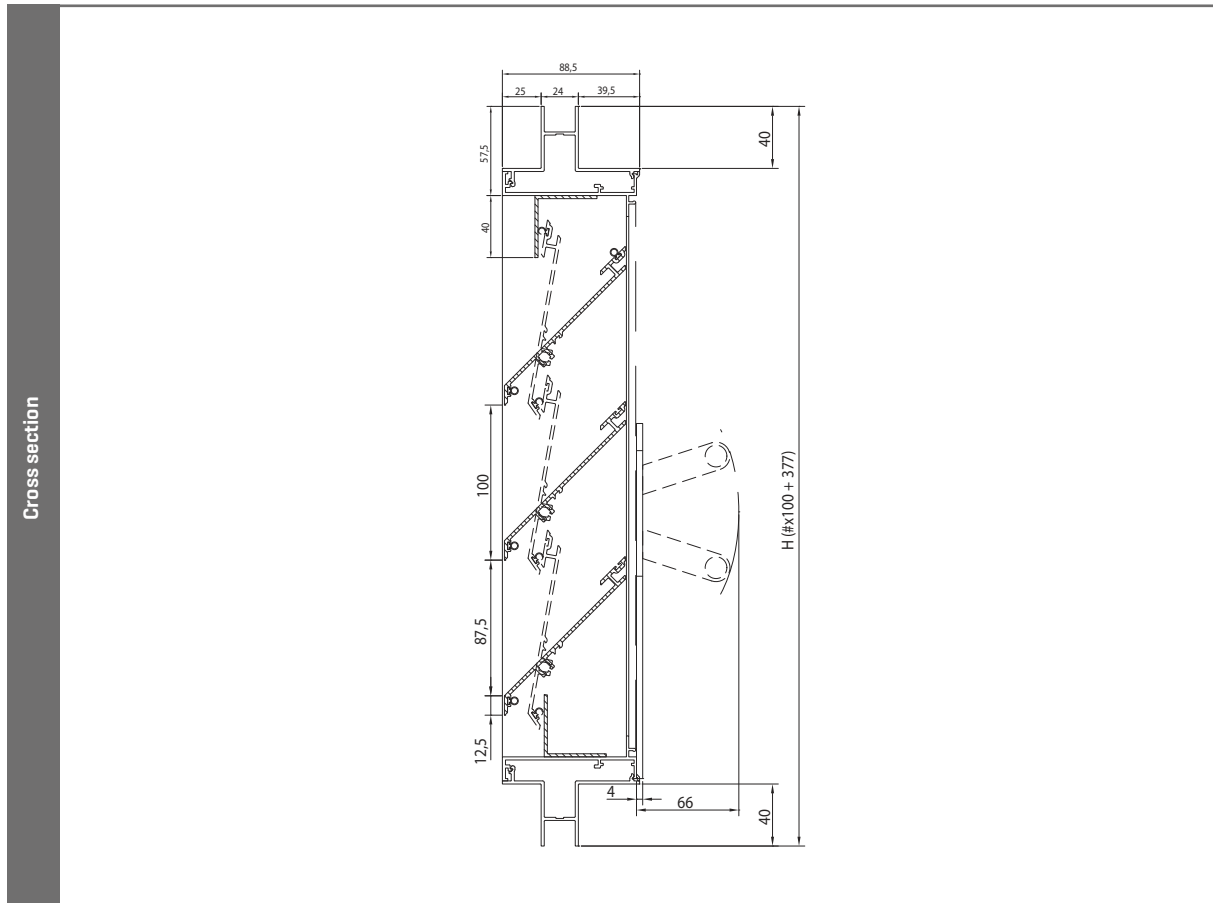

445/86

Acoustic wall louvre

SOUND-
REDUCTION
LOUVRE

ALUMINIUM



MATERIAL

- Made from aluminium sections: AlMgSi 0.5 [according to EN 12020-2]
- Stainless steel 304 mesh [6 x 6 mm]
- Finishing: anodized in satin colour [20 micron] or powder-coated in any RAL or Syntha Pulvin colour [40 micron]
- 100% stainless

DIMENSIONS

- Blade pitch: 60 mm
- Dimensions: depth to fit: 81.5 mm
- Flange size: 50 mm
- Height in steps of 60 mm [space between blades]
- Minimum dimensions: 230 x 230 mm

FIXING

- Brackets ref. 429

OPTIONS

- Stainless steel 304 insect screen 2,3x2,3 or mesh [10x10/20x20 mm] or without
- Insect screen or mesh in stainless steel 316
- Filter
- Without flange
- Water channel
- Drainage profile
- Removable mesh

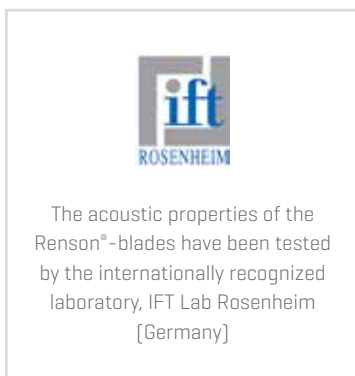
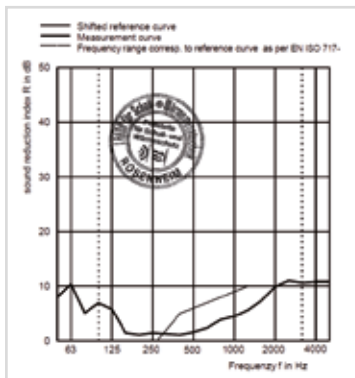

SOUND REDUCTION IN DB PER FREQUENCY

f in Hz	R in dB
63	10.4
125	5.8
250	1.5
500	1.6
1000	4.5
2000	9.9
4000	10.8



TECHNICAL SPECIFICATIONS

All properties are valid for the standard version of the Louvre, unless otherwise stated.

Airflow		[EN 13030]
K-factor [entry]		10,75
K-factor [discharge]		9,95
C _e coefficient		0,305
C _d coefficient		0,317
Comfort		[EN ISO 140-10, EN ISO 717-1]
Sound reduction R _w [C;C _r]		6 [-1; -2] dB
Technical data		
Visual free area		77%
Physical free area		34%
Total depth		86 mm



TECHNICAL DRAWINGS

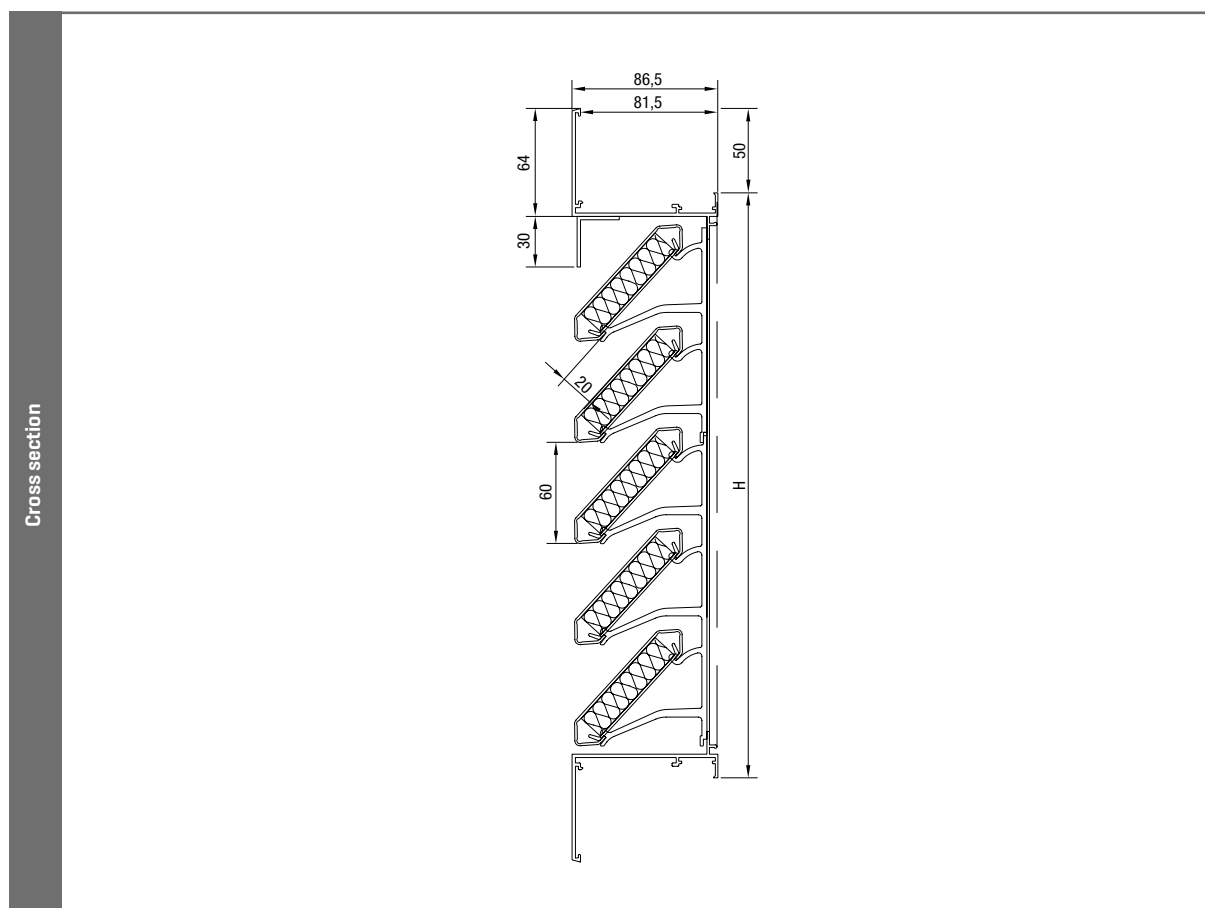

446/150

Acoustic wall louvre

SOUND-
REDUCTION
LOUVRE

ALUMINIUM

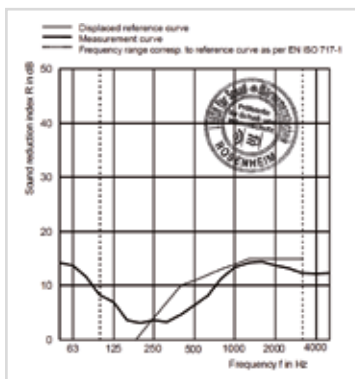

The acoustic properties of the Renson®-blades have been tested by the internationally recognized laboratory, IFT Lab Rosenheim (Germany) Water resistance tested by BSRIA laboratories.

MATERIAL

- Aluminum profiles AlMgSi 0,5 (according to EN 12020-2)
- Acoustic insulation material: non-flammable mineral wool
- Stainless steel mesh 304 6x6mm
- Finishing: anodized in satin colour (20 micron) or powder-coated in any RAL or Syntha Pulvin colour (40 micron)
- 100% stainless

DIMENSIONS

- Blade pitch: 150 mm
- Depth to fit: 143 mm
- Flange size: 55 mm
- Height in steps of 150 mm (space between blades)
- Minimum dimensions: 300 W x 410 H

FIXING

- Fixing bracket: installation with bracket no. 1428 possible
 - position 1: up to 100 mm wall thickness
 - position 2: for wall thickness up to 200 mm
- Screws: Fix the screws from the outside through the flange (screw holes upon request)
- Pull bracket: fixation with a long pull bracket and expander bolts for wall mounting or a short pull bracket for connection to a ventilation channel (pull bracket rod optional)
- Fixation on the backside: by screwing a hammerhead bolt to a structural backframe
- For louvres 446/300 larger than 3m², a backframe structure is required

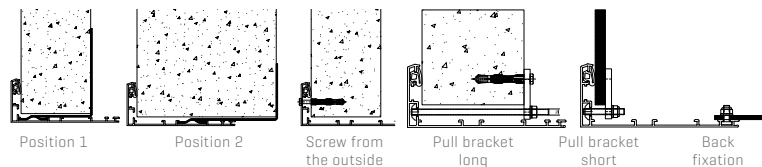

SEALING POSSIBILITIES

- Sealing gasket: suitable for reduction of contact sounds (option sealing gasket)
- PU sealing tape: against water infiltration (option PU sealing tape)
- Silicone seal: seal the flange on the outside with silicone (option silicone)

OPTIONS

- Water channel
- Drainage profile
- Stainless steel 304 insect screen 2,3x2,3 or mesh (10x10/20x20 mm) or without
- Insect screen or mesh in stainless steel 316
- Filter
- Without flange



TECHNICAL SPECIFICATIONS

All properties are valid for the standard version of the Louvre, unless otherwise stated.

Weatherability		[EN 13030]
Class [details see p. 12]		A4 [0 m/s]
Airflow		[EN 13030]
K-factor [entry]		38.46
K-factor [discharge]		34.48
C _e coefficient		0.161
C _d coefficient		0.169
Comfort		[EN ISO 140-10, EN ISO 717-1]
Sound reduction R _w [C;C _r]		11 [-1;-2] dB
Technical data		
Visual free area		54%
Physical free area		34%
Waterproof		A [0 m/s]
Total depth		150 mm

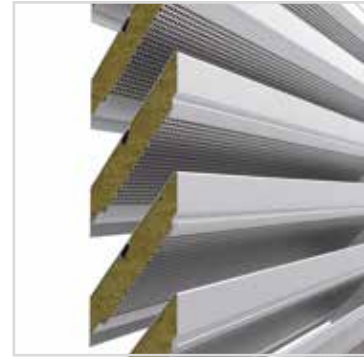

Section detail

SOUND REDUCTION IN DB PER FREQUENCY

f in Hz	R in dB
63	13.8
125	6.9
250	3.6
500	6.4
1000	13.4
2000	13.8
4000	12.1

TECHNICAL DRAWINGS

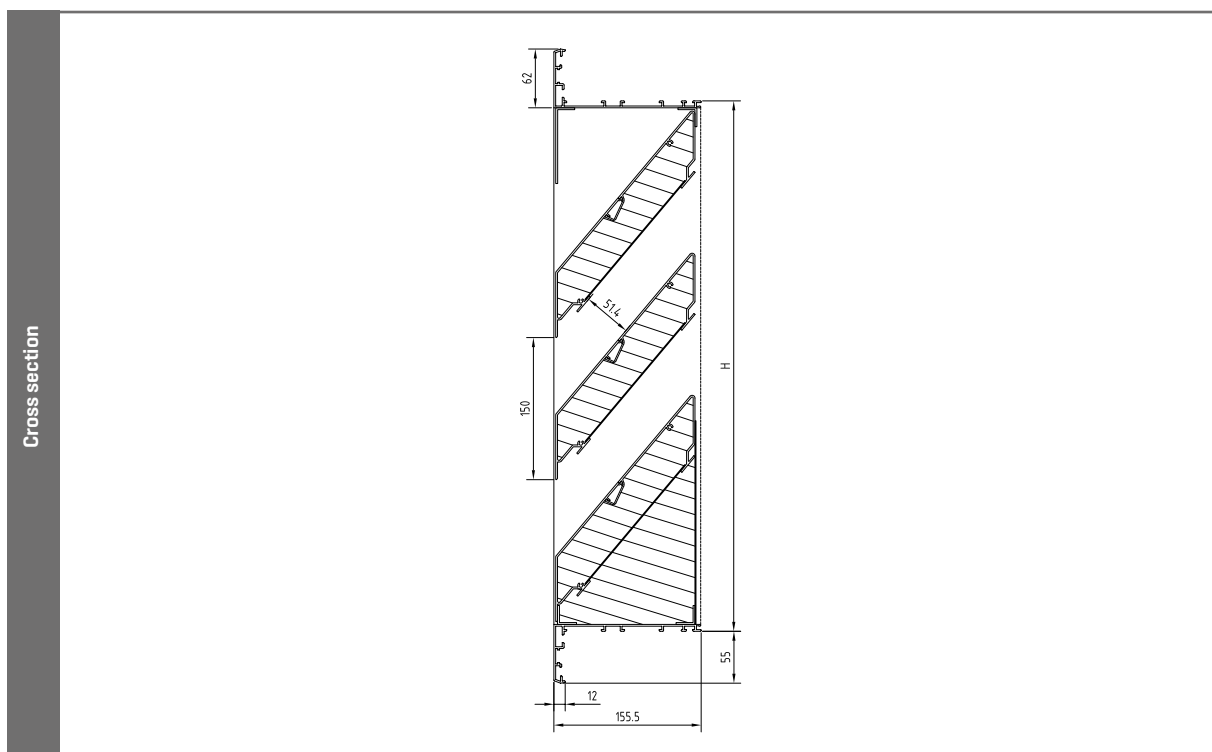

446/225

Acoustic wall louvre

SOUND-
REDUCTION
LOUVRE

ALUMINIUM

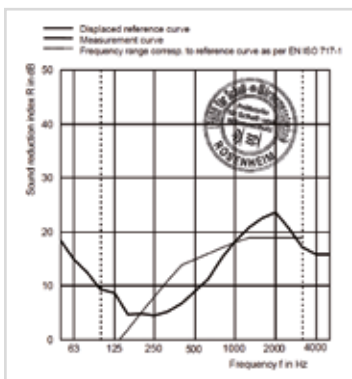

MATERIAL

- Aluminum profiles AlMgSi 0,5 (according to EN 12020-2)
- Acoustic insulation material: non-flammable mineral wool
- Stainless steel mesh 304 6x6mm
- Finishing: anodized in satin colour (20 micron) or powder-coated in any RAL or Syntha Pulvin colour (40 micron)
- 100% stainless

DIMENSIONS

- Blade pitch: 150 mm
- Depth to fit: 218 mm
- Flange size: 55 mm
- Height in steps of 150 mm (space between blades)
- Minimum dimensions: 300 W x 410 H

FIXING

- Fixing bracket: installation with bracket no. 1428 possible
 - position 1: up to 100 mm wall thickness
 - position 2: for wall thickness up to 200 mm
- Screws: Fix the screws from the outside through the flange (screw holes upon request)
- Pull bracket: fixation with a long pull bracket and expander bolts for wall mounting or a short pull bracket for connection to a ventilation channel (pull bracket rod optional)
- Fixation on the backside: by screwing a hammerhead bolt to a structural backframe
- For louvres 446/300 larger than 3m², a backframe structure is required

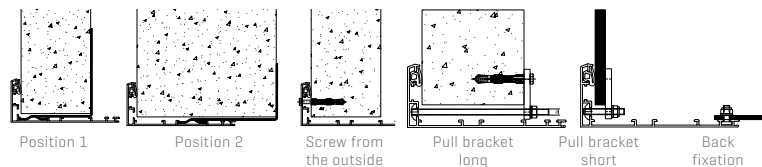

SEALING POSSIBILITIES

- Sealing gasket: suitable for reduction of contact sounds (option sealing gasket)
- PU sealing tape: against water infiltration (option PU sealing tape)
- Silicone seal: seal the flange on the outside with silicone (option silicone)

OPTIONS

- Water channel
- Drainage profile
- Stainless steel 304 insect screen 2,3x2,3 or mesh (10x10/20x20 mm) or without
- Insect screen or mesh in stainless steel 316
- Filter
- Without flange



TECHNICAL SPECIFICATIONS

All properties are valid for the standard version of the Louvre, unless otherwise stated.

Weatherability		(EN 13030)
Class [details see p. 12]		A4 [0 m/s]
Airflow		(EN 13030)
K-factor [entry]		37.30
K-factor [discharge]		41.90
C _e coefficient		0.164
C _d coefficient		0.150
Comfort		(EN ISO 140-10, EN ISO 717-1)
Sound reduction R _w [C;C _r]		15 [-1;-4] dB
Technical data		
Visual free area		54%
Physical free area		34%
Waterproof		A [1 m/s]
Total depth		225 mm

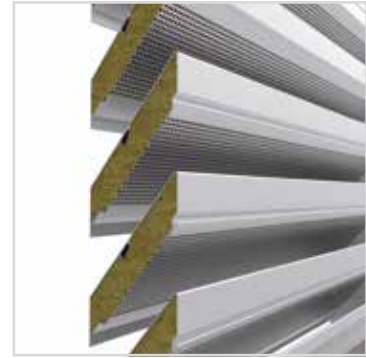

Section detail

SOUND REDUCTION IN DB PER FREQUENCY

f in Hz	R in dB
63	15.0
125	8.7
250	4.5
500	9.1
1000	18.2
2000	23.7
4000	15.8

TECHNICAL DRAWINGS

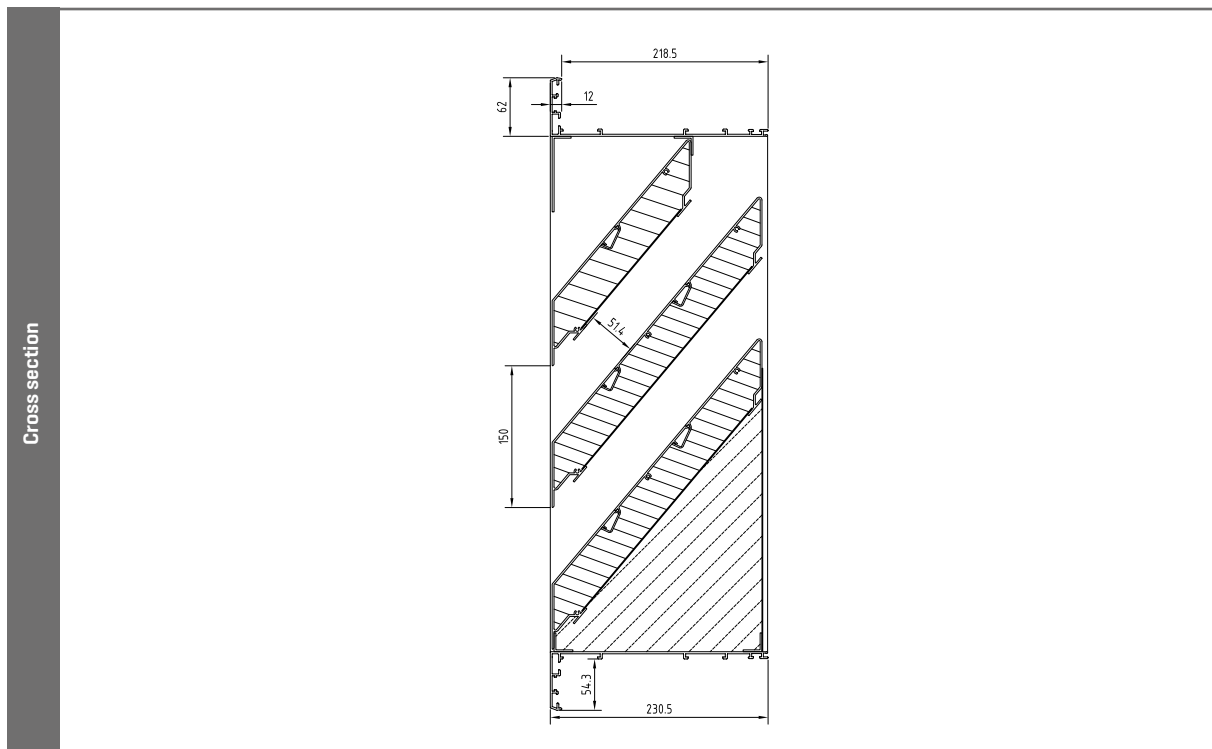

446/300

Acoustic wall louvre

SOUND-
REDUCTION
LOUVRE

ALUMINIUM

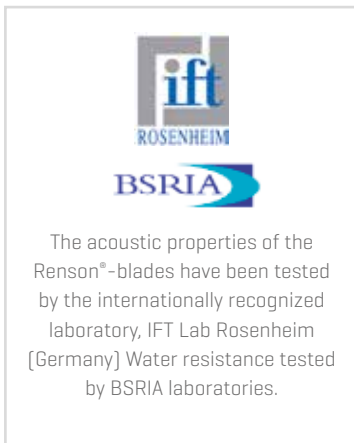
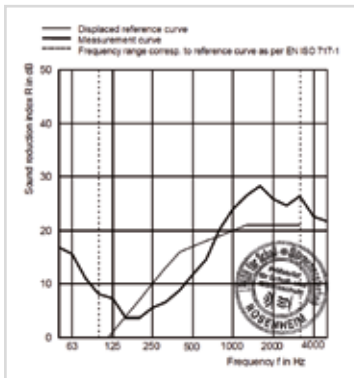

MATERIAL

- Aluminum profiles AlMgSi 0,5 (according to EN 12020-2)
- Acoustic insulation material: non-flammable mineral wool
- Stainless steel mesh 304 6x6mm
- Finishing: anodized in satin colour (20 micron) or powder-coated in any RAL or Syntha Pulvin colour (40 micron)
- 100% stainless

DIMENSIONS

- Blade pitch: 150 mm
- Depth to fit: 293 mm
- Flange size: 55 mm
- Height in steps of 150 mm (space between blades)
- Minimum dimensions: 311 W x 421 H

FIXING

- Fixing bracket: installation with bracket no. 1428 possible
 - position 1: up to 100 mm wall thickness
 - position 2: for wall thickness up to 200 mm
- Screws: Fix the screws from the outside through the flange (screw holes upon request)
- Pull bracket: fixation with a long pull bracket and expander bolts for wall mounting or a short pull bracket for connection to a ventilation channel (pull bracket rod optional)
- Fixation on the backside: by screwing a hammerhead bolt to a structural backframe
- For louvres 446/300 larger than 3m², a backframe structure is required

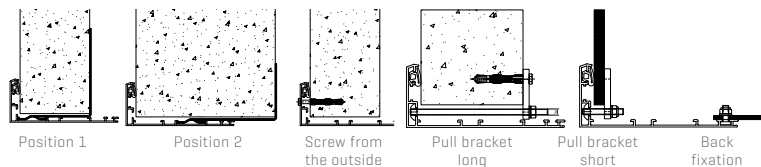

SEALING POSSIBILITIES

- Sealing gasket: suitable for reduction of contact sounds (option sealing gasket)
- PU sealing tape: against water infiltration (option PU sealing tape)
- Silicone seal: seal the flange on the outside with silicone (option silicone)

OPTIONS

- Drainage profile
- Stainless steel 304 insect screen 2,3x2,3 or mesh (10x10/20x20 mm) or without
- Insect screen or mesh in stainless steel 316
- Filter
- Without flange



TECHNICAL SPECIFICATIONS

All properties are valid for the standard version of the Louvre, unless otherwise stated.

Weatherability		[EN 13030]
Class [details see p. 12]		A4 [0 m/s]
Airflow		[EN 13030]
K-factor [entry]		45.93
K-factor [discharge]		45.93
C _e coefficient		0.148
C _d coefficient		0.148
Comfort		[EN ISO 140-10, EN ISO 717-1]
Sound reduction R _w [C;C _r]		17 [-1;-4] dB
Technical data		
Visual free area		54%
Physical free area		34%
Waterproof		A [1 m/s]
Total depth		300 mm

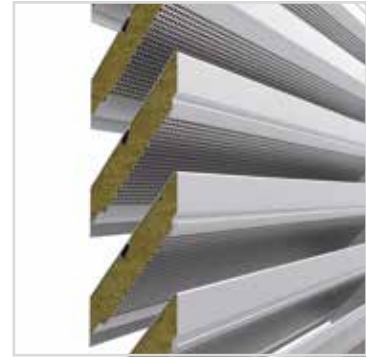

Section detail

SOUND REDUCTION IN DB PER FREQUENCY

f in Hz	R in dB
63	15.7
125	7.3
250	5.5
500	11.8
1000	24.0
2000	25.9
4000	22.6

TECHNICAL DRAWINGS

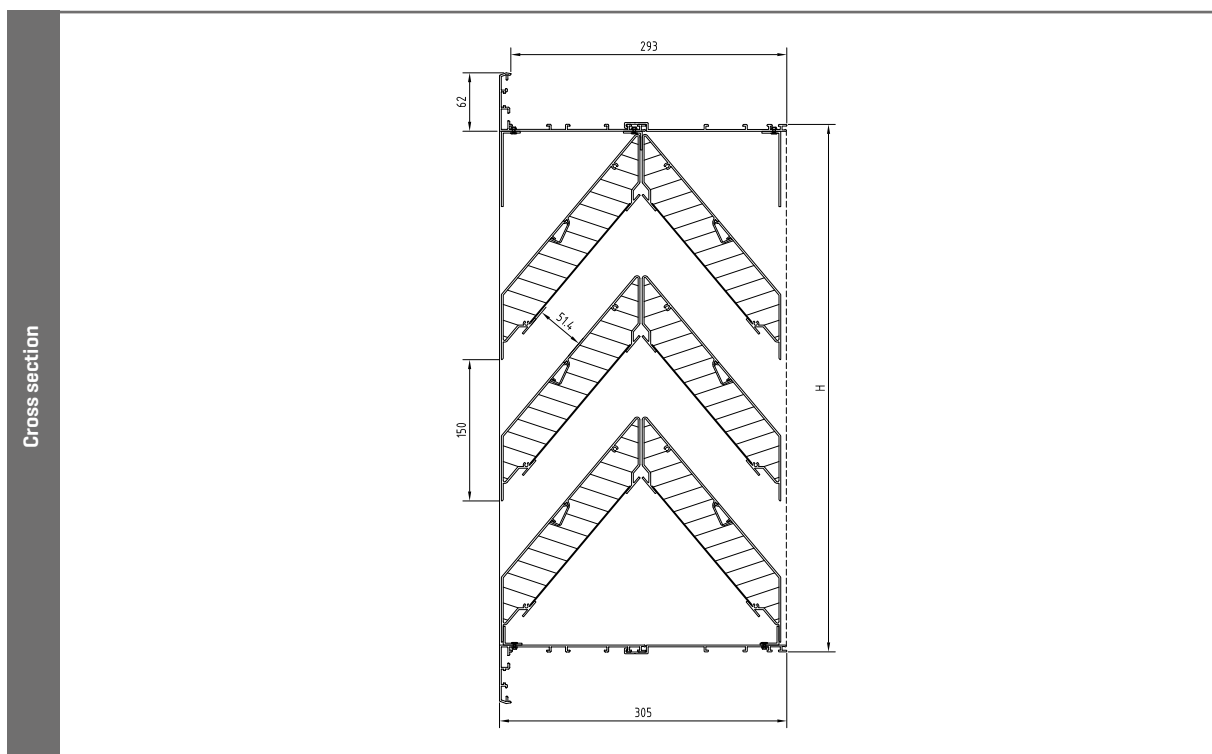

447/150

Acoustic wall louvre

SOUND-
REDUCTION
LOUVRE

ALUMINIUM

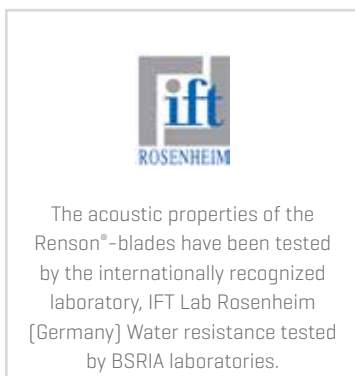
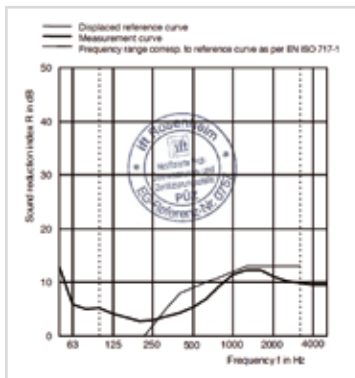

MATERIAL

- Aluminum profiles AlMgSi 0,5 (according to EN 12020-2)
- Acoustic insulation material: non-flammable mineral wool
- Stainless steel mesh 304 6x6mm
- Finishing: anodized in satin colour (20 micron) or powder-coated in any RAL or Syntha Pulvin colour (40 micron)
- 100 % stainless

DIMENSIONS

- Blade pitch: 170 mm
- Depth to fit: 143 mm
- Flange size: 55 mm
- Height in steps of 150 mm (space between blades)
- Minimum dimensions: 300 W x 430 H

FIXING

- Fixing bracket: installation with bracket no. 1428 possible
 - position 1: up to 100 mm wall thickness
 - position 2: for wall thickness up to 200 mm
- Screws: Fix the screws from the outside through the flange (screw holes upon request)
- Pull bracket: fixation with a long pull bracket and expander bolts for wall mounting or a short pull bracket for connection to a ventilation channel (pull bracket rod optional)
- Fixation on the backside: by screwing a hammerhead bolt to a structural backframe.

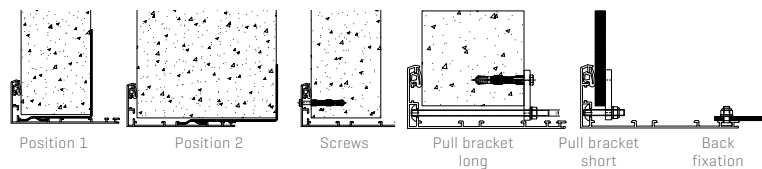

SEALING POSSIBILITIES

- Sealing gasket: suitable for reduction of contact sounds (option sealing gasket)
- PU sealing tape: against water infiltration (option PU sealing tape)
- Silicone seal: seal the flange on the outside with silicone (option silicone)

OPTIONS

- Water channel
- Drainage profile
- Stainless steel 304 insect screen 2,3x2,3 or mesh (10x10/20x20 mm) or without
- Insect screen or mesh in stainless steel 316
- Filter
- Without flange



TECHNICAL SPECIFICATIONS

All properties are valid for the standard version of the Louvre, unless otherwise stated.

Airflow		[EN 13030]
K-factor [entry]		25.46
K-factor [discharge]		25.15
C _e coefficient		0.198
C _d coefficient		0.200
Comfort		[EN ISO 140-10, EN ISO 717-1]
Sound reduction R _w [C;C _v]		9 [0;-1] dB
Technical data		
Visual free area		59%
Physical free area		37%
Total depth		150 mm

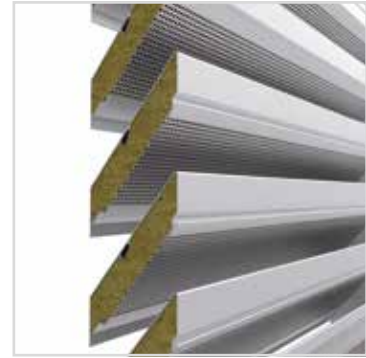

Section detail

SOUND REDUCTION IN DB PER FREQUENCY

f in Hz	R in dB
63	5.9
125	4.2
250	2.9
500	5.4
1000	11.5
2000	11.2
4000	9.6

TECHNICAL DRAWINGS

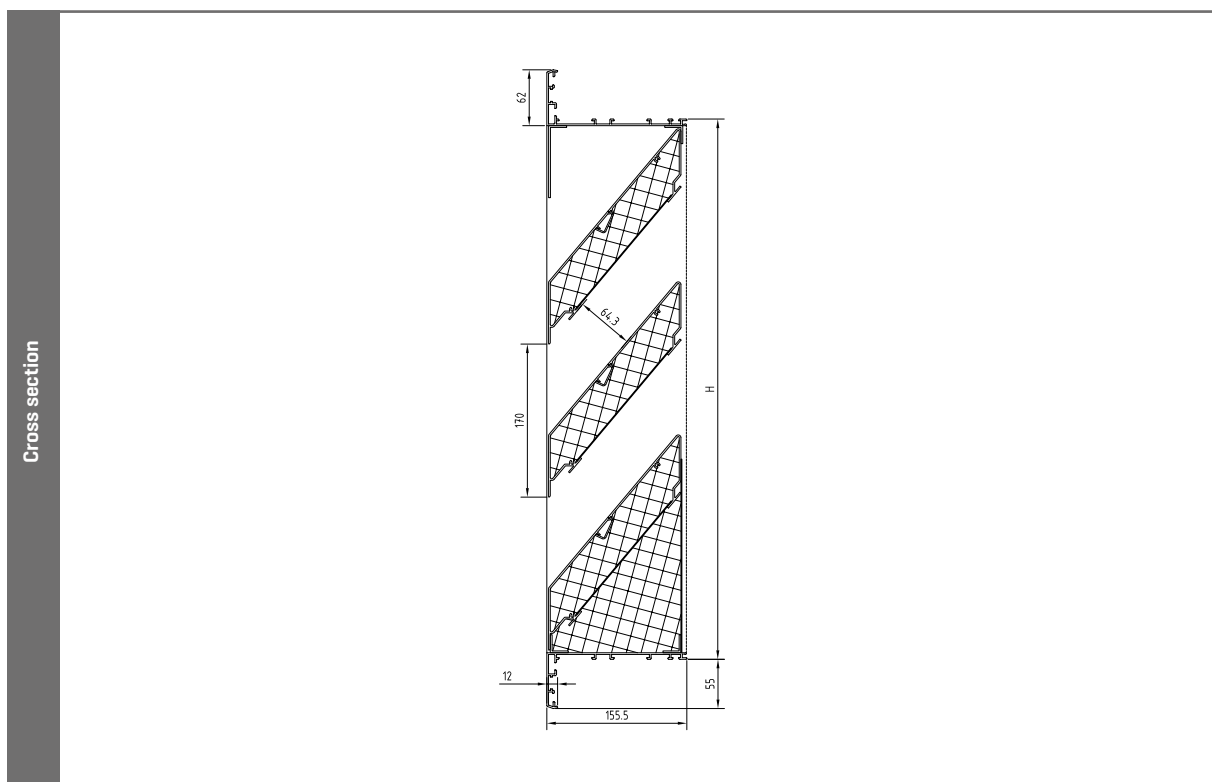

447/225

Acoustic wall louvre

SOUND-
REDUCTION
LOUVRE

ALUMINIUM

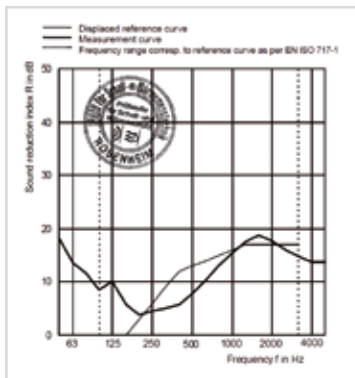

The acoustic properties of the Renson®-blades have been tested by the internationally recognized laboratory, IFT Lab Rosenheim (Germany) Water resistance tested by BSRIA laboratories.

MATERIAL

- Aluminum profiles AlMgSi 0,5 (according to EN 12020-2)
- Acoustic insulation material: non-flammable mineral wool
- Stainless steel mesh 304 6x6mm
- Finishing: anodized in satin colour (20 micron) or powder-coated in any RAL or Syntha Pulvin colour (40 micron)
- 100 % stainless

DIMENSIONS

- Blade pitch: 170 mm
- Depth to fit: 218 mm
- Flange size: 55 mm
- Height in steps of 150 mm (space between blades)
- Minimum dimensions: 300 W x 430 H

FIXING

- Fixing bracket: installation with bracket no. 1428 possible
 - position 1: up to 100 mm wall thickness
 - position 2: for wall thickness up to 200 mm
- Screws: Fix the screws from the outside through the flange (screw holes upon request)
- Pull bracket: fixation with a long pull bracket and expander bolts for wall mounting or a short pull bracket for connection to a ventilation channel (pull bracket rod optional)
- Fixation on the backside: by screwing a hammerhead bolt to a structural backframe.

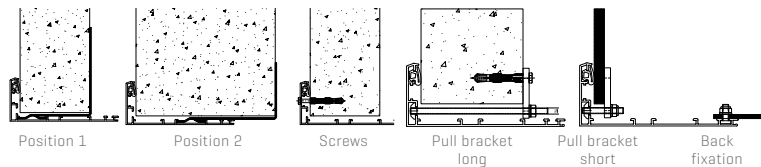

SEALING POSSIBILITIES

- Sealing gasket: suitable for reduction of contact sounds (option sealing gasket)
- PU sealing tape: against water infiltration (option PU sealing tape)
- Silicone seal: seal the flange on the outside with silicone (option silicone)

OPTIONS

- Water channel
- Drainage profile
- Stainless steel 304 insect screen 2,3x2,3 or mesh (10x10/20x20 mm) or without
- Insect screen or mesh in stainless steel 316
- Filter
- Without flange



TECHNICAL SPECIFICATIONS

All properties are valid for the standard version of the Louvre, unless otherwise stated.

Airflow		[EN 13030]
K-factor [entry]		28.58
K-factor [discharge]		30.88
C _e coefficient		0.187
C _d coefficient		0.180
Comfort		[EN ISO 140-10, EN ISO 717-1]
Sound reduction R _w [C;C _v]		13 [-1;-3] dB
Technical data		
Visual free area		59%
Physical free area		37%
Total depth		225 mm

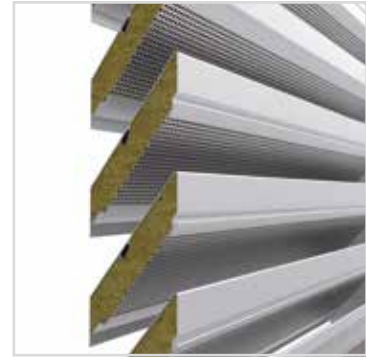

Section detail

SOUND REDUCTION IN DB PER FREQUENCY

f in Hz	R in dB
63	13.6
125	10.1
250	4.6
500	7.8
1000	15.4
2000	17.8
4000	13.7

TECHNICAL DRAWINGS

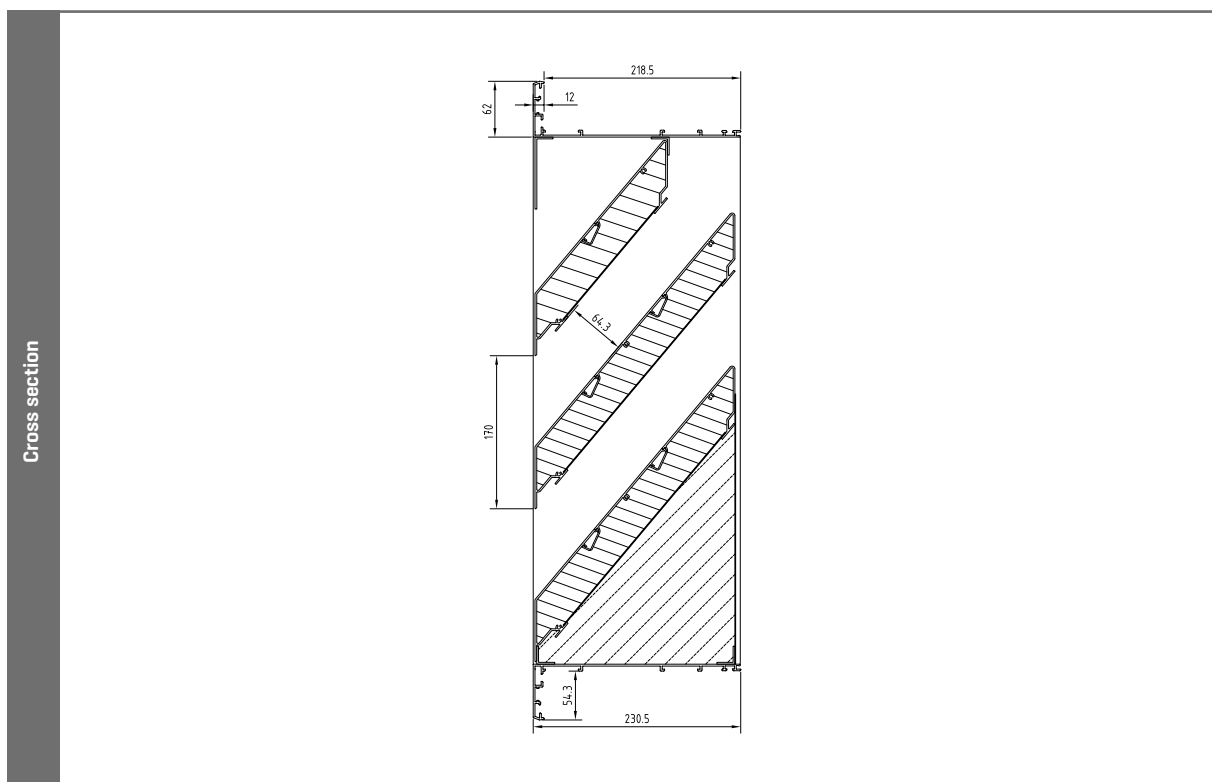

421 RC2

Burglar resistance louvre class RC2

BURGLAR-
RESISTANT
LOUVRE

ALUMINIUM



MATERIAL

- Made from aluminum profiles AlMgSi 0.5 [according to EN 12020-2]
- Stainless steel insect mesh 304 - 2.3 x 2.3 mm
- Finishing: anodized in satin colour [20 micron] or powder-coated in any RAL or Syntha Pulvin colour [40 micron]

DIMENSIONS

- Blade pitch: 50 mm
- Depth: 46 mm
- Flange size: 40 mm
- Minimum dimensions: 250 x 250 mm

OPTIONS

- Stainless steel 304 mesh [6x6/10x10/20x20 mm] or without
- Insect screen or mesh in stainless steel 316
- Without flange
- Water channel
- Drainage profile
- Removable insect mesh
- Filter

FEATURES

- Aesthetical and functional high-quality louvre
- Burglar resistance according to class RC2, certificate surface 0.44 <math><0 <6 \text{ m}^2</math>, in accordance to EN 1627 up to 1630 and including [Sept. 2011]
- Easy to install using brackets
- 100% stainless:
 - Entirely assembled of aluminum profiles
 - All connecting pieces in aluminum and stainless steel

TYPICAL APPLICATIONS

- Schools
- Shops
- Apartments



TECHNICAL SPECIFICATIONS

All properties are valid for the standard version of the Louvre, unless otherwise stated.

Airflow	[EN 13030]
K-factor [entry]	13.82
K-factor [discharge]	12.85
C _e coefficient	0.269
C _d coefficient	0.279
Technical data	
Visual free area	70%
Physical free area	43%
IP class [louvre with mesh; electrical installation at least 100 mm from louvre]	IP2XD

AIR FLOW

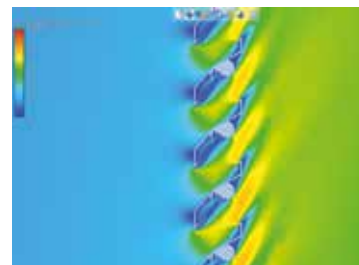

Supply

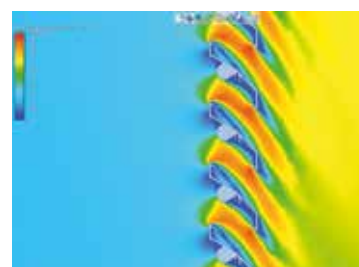

Extraction

TECHNICAL DRAWINGS

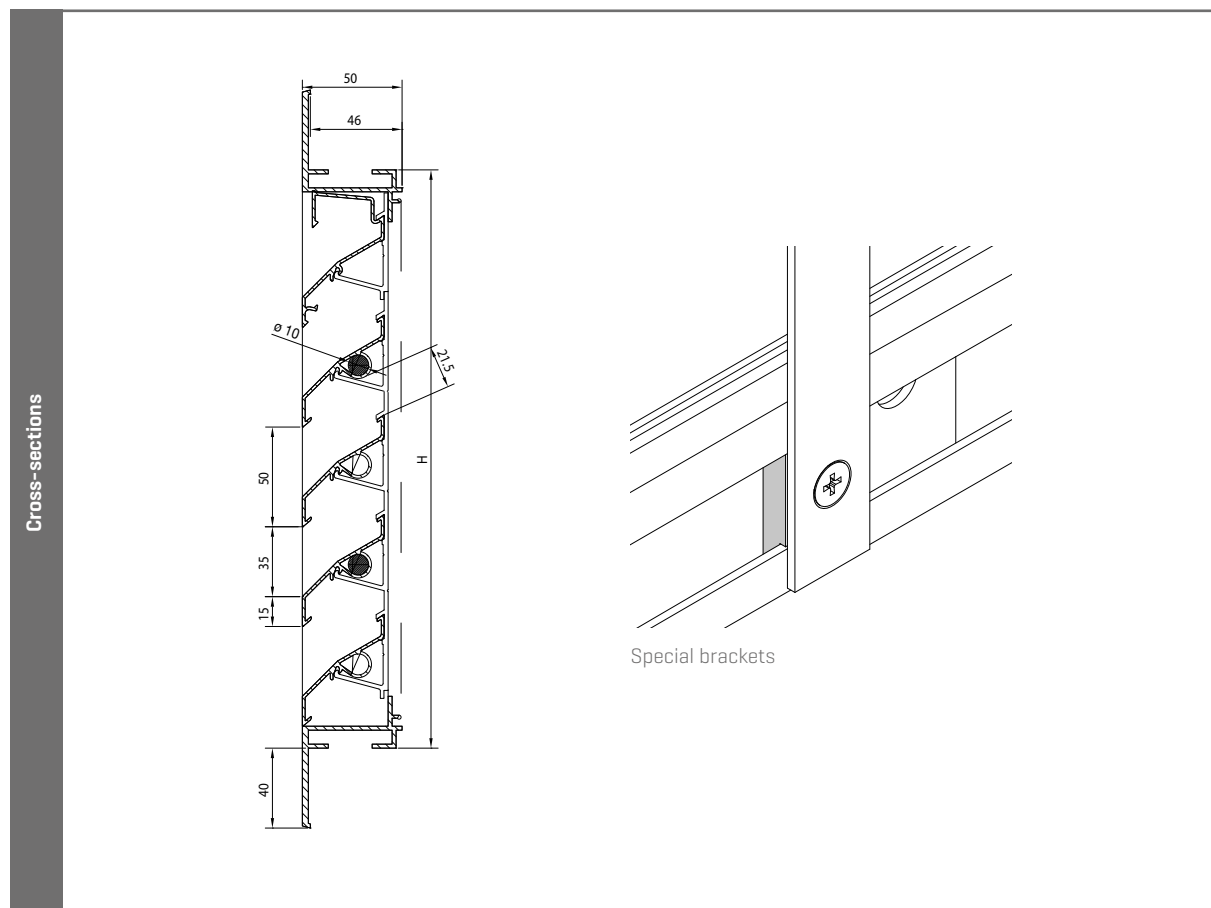

424RC2

Burglar resistance glazed-in louvre class RC2

BURGLAR-
RESISTANT
LOUVRE

ALUMINIUM



MATERIAL

- Made from aluminium sections: AlMgSi 0,5 [according to EN 12020-2]
- Stainless steel 304 insect mesh [2,3 x 2,3 mm]
- Finishing: anodized in satin colour [20 micron] or powder coated in any RAL or Syntha Pulvin colour [40 micron]

DIMENSIONS

- Blade pitch: 50 mm
- Minimum dimensions: 220 x 220 mm
- Flange size: 24 or 28 mm

FIXING

- Suitable for 24 or 28 mm glazing sections

FEATURES

- Aesthetical and functional high-quality louvre
- Burglar resistance according to class RC2 [WK2] according to EN 1627 -1630 [sept.2011] for surfaces $0,481 < A < 6,06 \text{ m}^2$; official test report WTCB available upon request
- 100% stainless:
 - Entirely assembled of aluminium profiles
 - All connecting pieces in aluminium and stainless steel

OPTIONS

- Stainless steel 304 mesh [6x6/10x10/20x20 mm] or without
- Insect screen or mesh in stainless steel 316
- Drainage profile
- Water channel
- Removable insect mesh
- Filter

TYPICAL APPLICATIONS

- Schools
- Shops
- Nightcooling



TECHNICAL SPECIFICATIONS

All properties are valid for the standard version of the Louvre, unless otherwise stated.

Airflow		[EN 13030]
K-factor [entry]		13.82
K-factor [discharge]		12.85
C _e coefficient		0.269
C _d coefficient		0.279
Technical data		
Visual free area		70%
Physical free area		43%
IP class [louvre with mesh; electrical installation at 105 mm at least]		IP2XD



TECHNICAL DRAWINGS

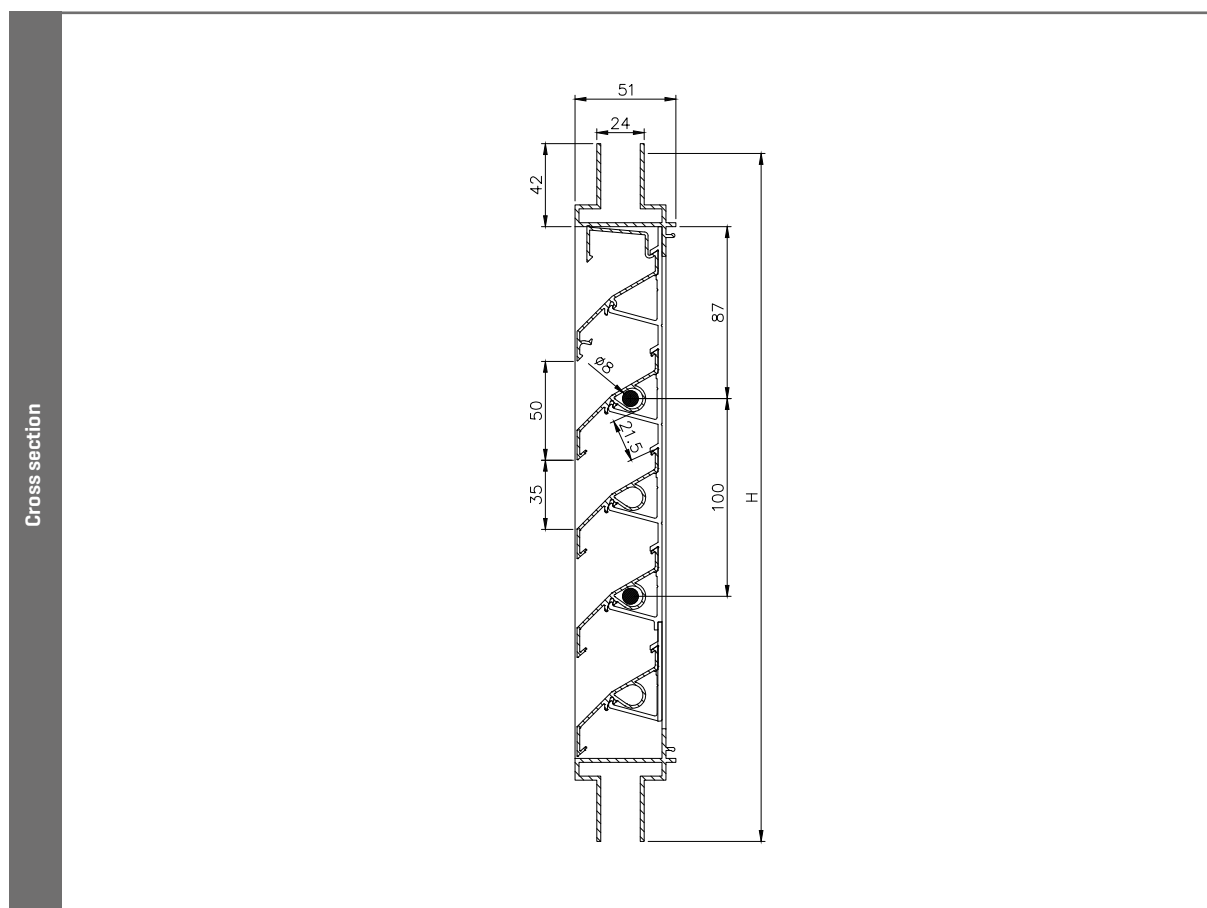

431RC2

Fall-through safe and burglar-resistant surface-mounted louvre

BURGLAR-
RESISTANT
LOUVRE

ALUMINIUM



MATERIAL

- Made from aluminum profiles AlMgSi 0.5 [according to EN 12020-2]
- Stainless steel insect mesh 304 - 2.3 x 2.3 mm
- Finishing: anodized in satin colour [20 micron] or powder-coated in any RAL or Syntha Pulvin colour [40 micron]

DIMENSIONS

- Blade pitch: 33,3 mm
- Thickness: 31 mm
- Minimum dimensions: 170 x 170 mm

FIXING

- Surface mounted by means of burglar resistance screws type Secu-Fast® Pin Hexagon diam. 4,2 x 38 mm A2 [included]

FEATURES

- Aesthetical and functional high-quality louvre
- Burglar resistance according to class RC2
- 100% stainless:
 - Entirely assembled of aluminum profiles
 - All connecting pieces in aluminum and stainless steel
- Fall-through safe according to EN 13049, depending of dimensions and base material

OPTIONS

- Stainless steel 304 mesh [6x6/10x10/20x20 mm] or without
- Insect screen or mesh in stainless steel 316

TYPICAL APPLICATIONS

- Schools
- Shops
- Nightcooling



TECHNICAL SPECIFICATIONS

All properties are valid for the standard version of the Louvre, unless otherwise stated.

Airflow		[EN 13030]
K-factor [entry]		23.56
K-factor [discharge]		25.51
C_e coefficient		0.206
C_d coefficient		0.198
Technical data		
Visual free area		59%
Physical free area		40.5%



TECHNICAL DRAWINGS

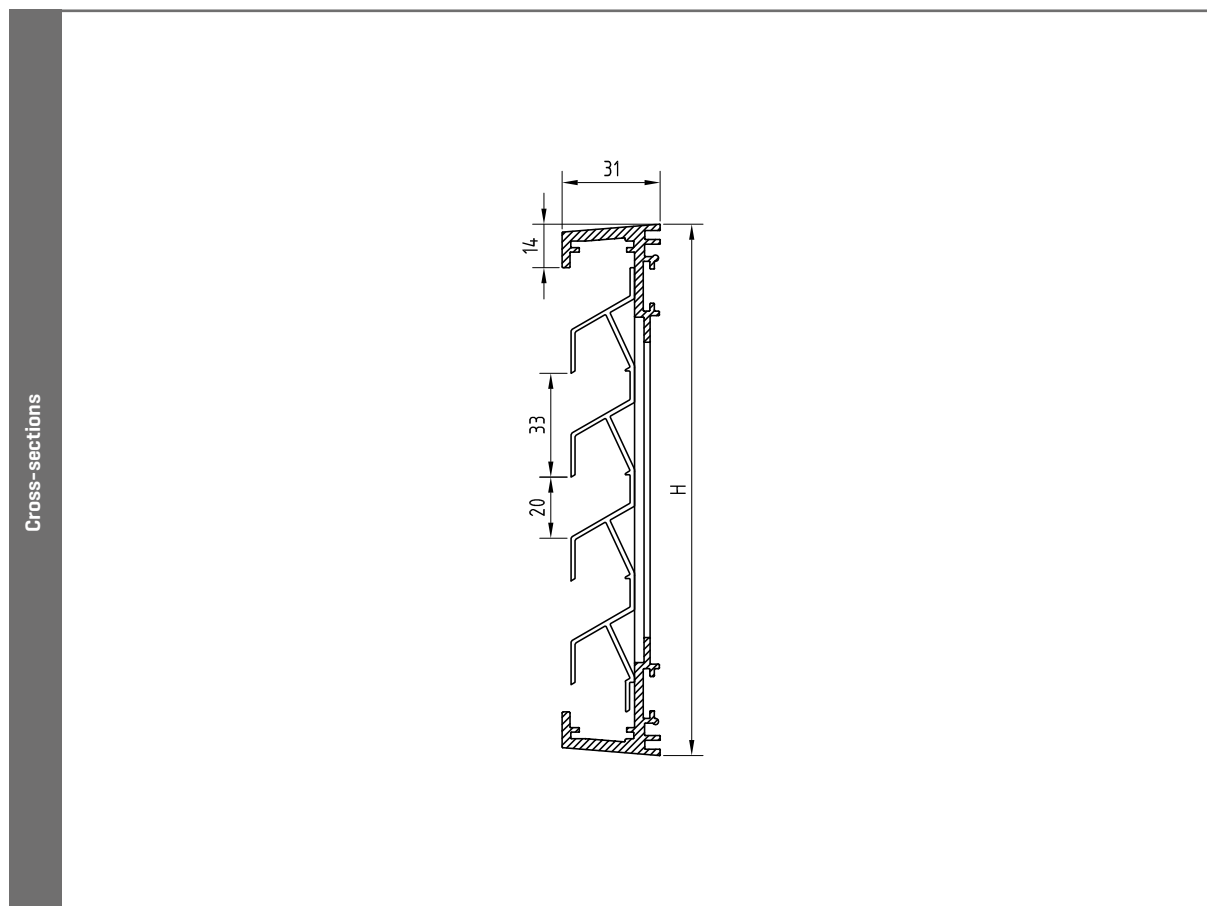

421 RC3

Burglar resistance louvre class RC3

BURGLAR-
RESISTANT
LOUVRE

ALUMINIUM



MATERIAL

- Made from aluminium profiles AlMgSi 0.5 [in accordance with EN 12020-2]
- Stainless steel insect mesh 304 - 2.3 x 2.3 mm
- Finishing: anodized in satin colour (20 micron) or powdercoated in any RAL or Syntha Pulvin colour (40 micron)

DIMENSIONS

- Blade pitch: 50 mm
- Depth to fit: 46 mm
- Thickness: 40 mm
- Minimum dimensions: 300 x 300 mm

OPTIONS

- Stainless steel 304 mesh (6x6/10x10/20x20 mm) or without
- Insect screen or mesh in stainless steel 316
- Water channel
- Drainage profile
- Removable insect screen
- Filter

FEATURES

- Fall-proof resistance according to DIN EN 13049, depending on dimensions and substructure
- Aesthetic and functional high-quality louvres
- Burglar-resistant according to class RC3, certificate surface area $0.44 < a < 6 \text{ m}^2$, in accordance with EN 1627 through 1630 (Sept 2011)
- Easy to assemble thanks to the stainless steel dowels included in the delivery
- 100% stainless steel:
 - Entirely constructed of aluminium profiles
 - All connector materials are made of aluminium and stainless steel

TYPICAL APPLICATIONS

- Schools
- Shops
- Apartment blocks



TECHNICAL SPECIFICATIONS

All properties are valid for the standard version of the Louvre, unless otherwise stated.

Airflow		[EN 13030]
K-factor [entry]		13.82
K-factor [discharge]		12.85
C _e coefficient		0.269
C _d coefficient		0.279
Technical data		
Visual free area		70%
Physical free area		43%
IP class [louvre with mesh; electrical installation at least 100 mm from louvre]		IP2XD



TECHNICAL DRAWINGS

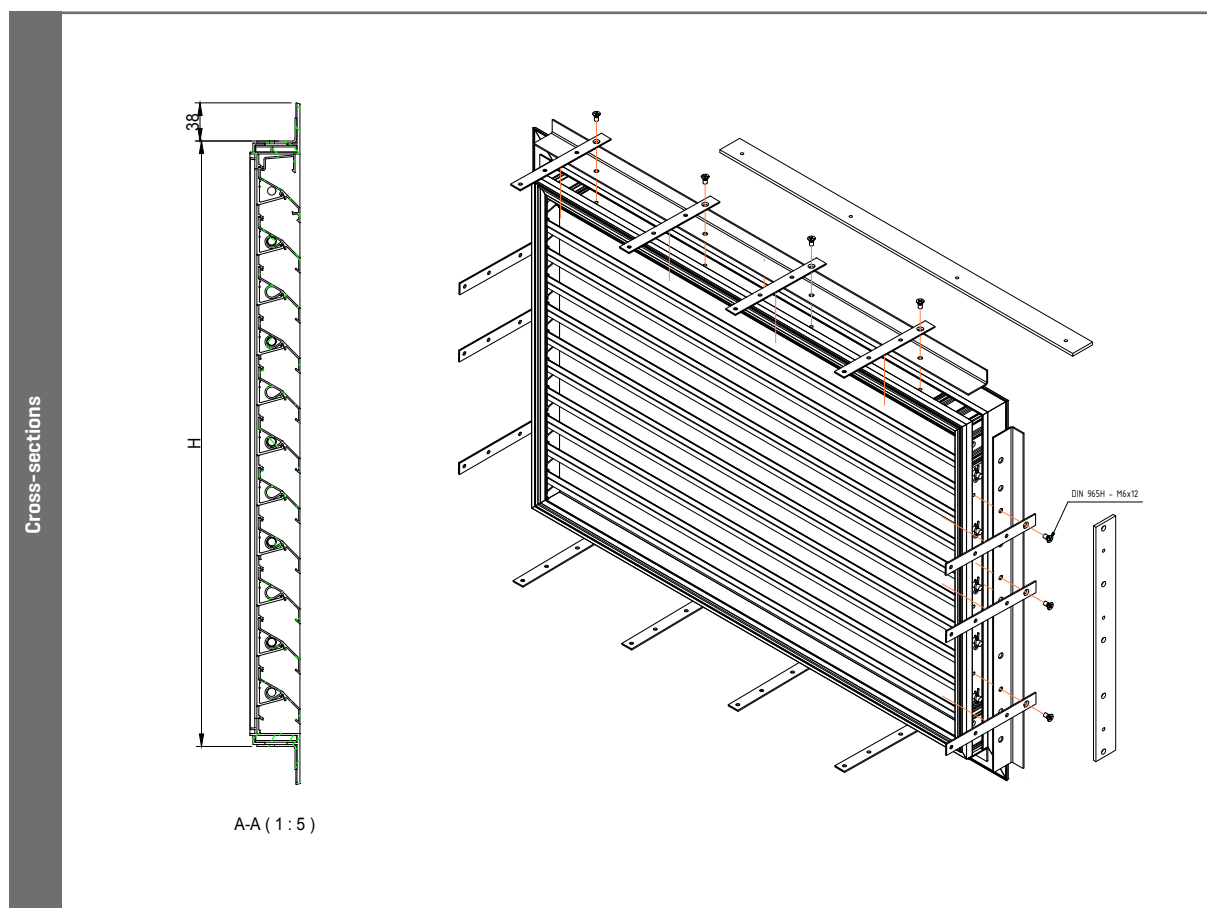

423RC4

AVAILABLE UNTIL END OF STOCK

Burglar resistance louvre class RC4

BURGLAR-
RESISTANT
LOUVRE

ALUMINIUM

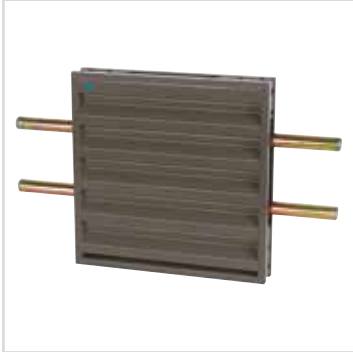

MATERIAL

- Made from aluminum profiles AlMgSi 0.5 [according to EN 12020-2]
- Stainless steel insect mesh 304 - 2.3 x 2.3 mm
- Finishing: anodized in satin colour [20 micron] or powder-coated in any RAL or Syntha Pulvin colour [40 micron]
- Every second blade has an inox steel bar of diam. 20 mm

DIMENSIONS

- Blade pitch: 50 mm
- Depth: 50 mm
- Frame without flange
- Minimum dimensions: 250 x 250 mm
- Maximum width: 2800 mm

FIXING

- The steel bars of the louvre need to be built into the wall.
- Frame without flange

OPTIONS

- Stainless steel 304 mesh [6x6/10x10/20x20 mm] or without
- Insect screen or mesh in stainless steel 316
- Water channel
- Drainage profile
- Filter

FEATURES

- Aesthetical and functional high-quality louvre

TYPICAL APPLICATIONS

- Banks, IT rooms, museums and jewellers.



TECHNICAL SPECIFICATIONS

All properties are valid for the standard version of the Louvre, unless otherwise stated.

Airflow		[EN 13030]
K-factor [entry]		27.06
K-factor [discharge]		27.28
C _e coefficient		0.193
C _d coefficient		0.192
Technical data		
Visual free area		70%
Physical free area		22%
IP class		IP2XD



TECHNICAL DRAWINGS

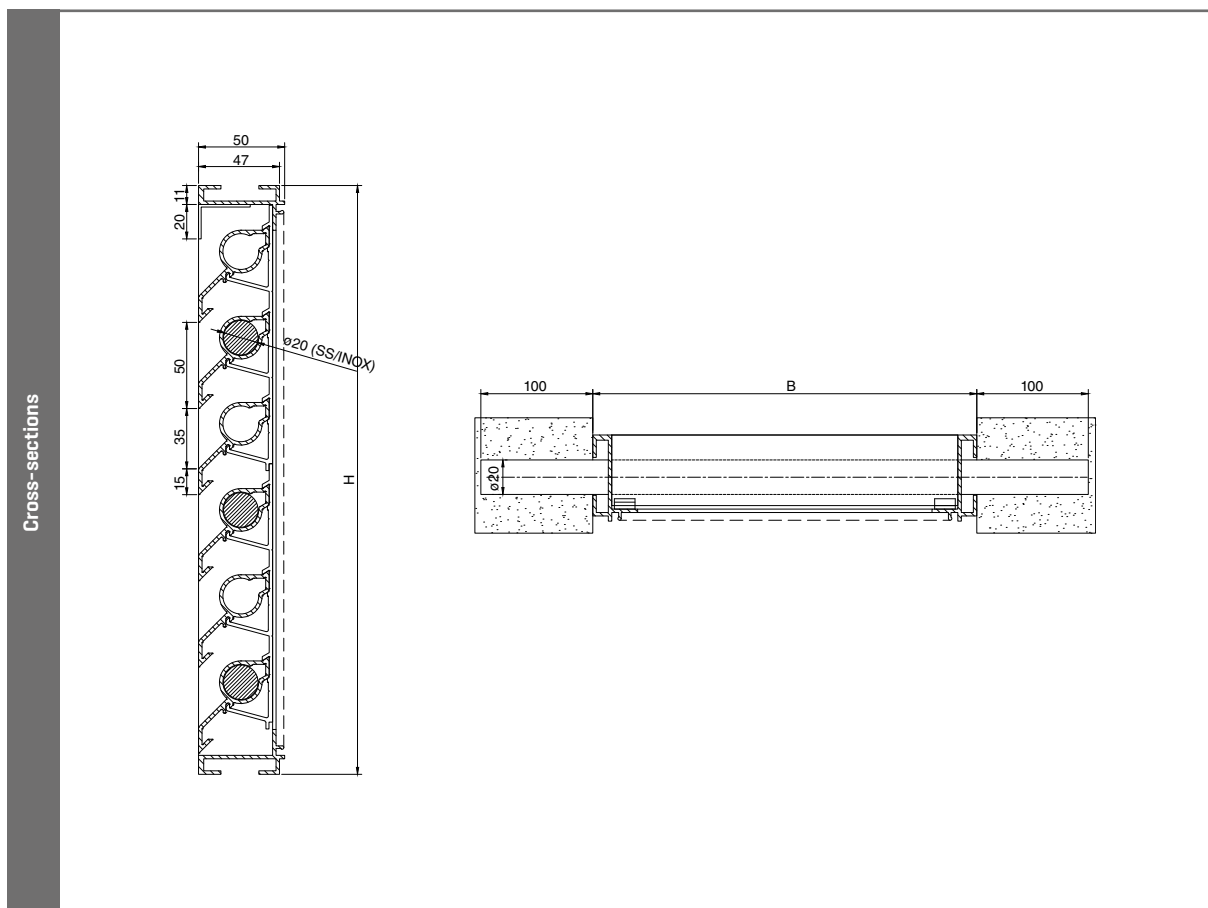

440

Turret

ROOF TURRET

ALUMINIUM



MATERIAL

- Made from aluminium sections: AlMgSi 0.5 [according to EN 12020-2]
- Finishing: anodized in satin colour [20 micron] or powder-coated in any RAL or Syntha Pulvin colour [40 micron]
- Cover plate
 - In aluminium sheet
 - Acoustic version optional

DIMENSIONS

- Maximum dimensions in one piece 900 mm width, 1900 mm long and 1000 mm height
- Larger sizes possible on request

TYPES

All blade types possible, for example:

- 440/11: with blade L.033.01 of louvre 411 [blade pitch 33 mm]
- 440/21: with blade L.050.00 of louvre 421 [blade pitch 50 mm]
- 440/80: with blade L.060HF of louvre 480 [blade pitch 60 mm]
- 440/81: with blade L.050HF of louvre 481 [blade pitch 50 mm]

OPTIONS

- Water channel

TYPICAL APPLICATIONS

- Office ventilation [Nightcooling]
- Manufacturing plants

TECHNICAL DRAWINGS

Cross-sections

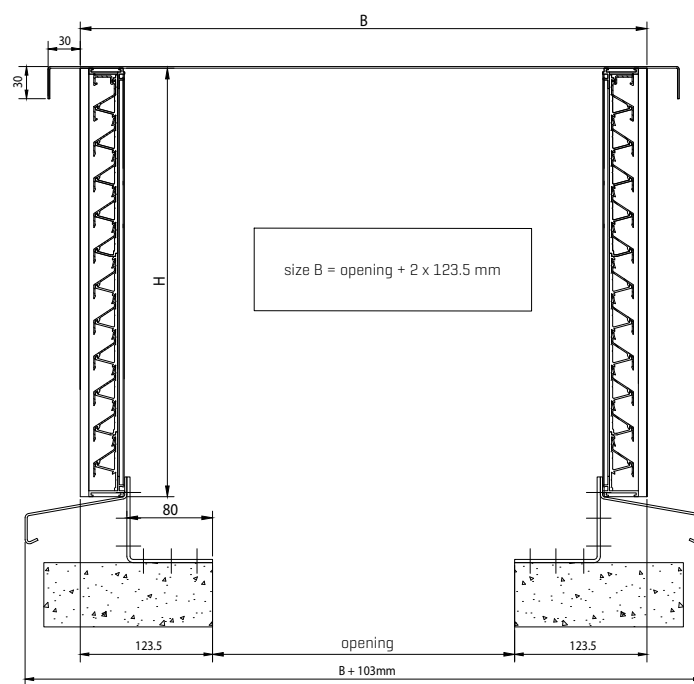
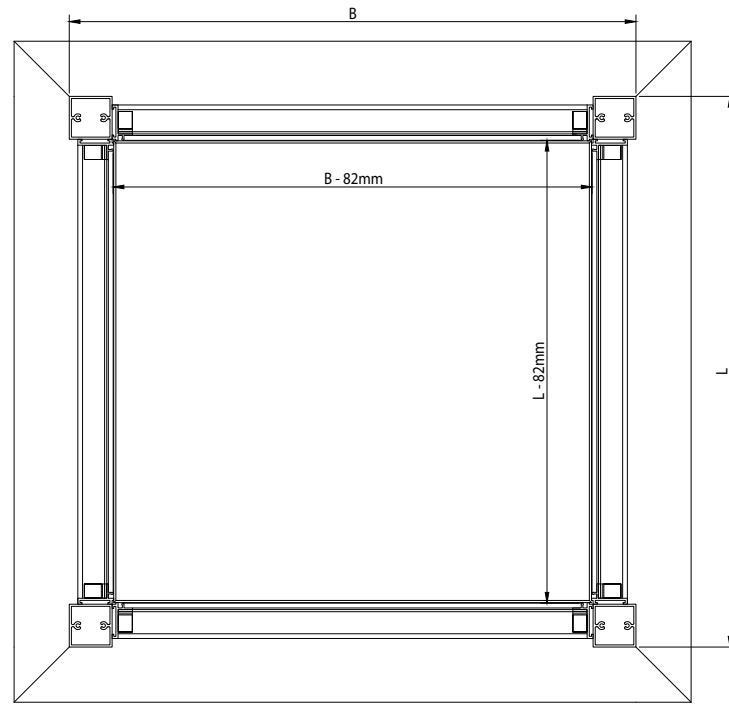

311

Convactor grille

FLOOR GRILLE

ALUMINIUM

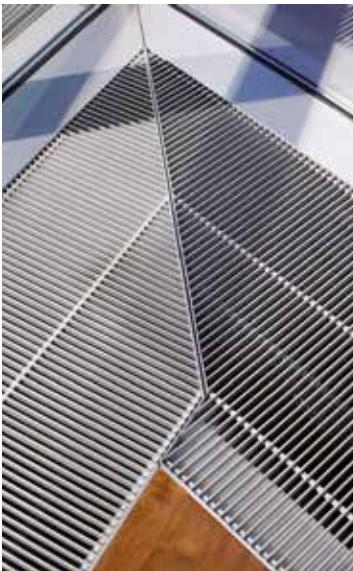

MATERIAL

- Made from aluminium sections: AlMgSi 0.5 [according to EN 12020-2]
- Finishing: anodised in satin colour (20 microns) or powder-coated in any RAL or Syntha Pulvin colour (40 microns)
- The frame is lined with a rubber gasket to guarantee a reduced noise level

DIMENSIONS

- Bar spacing: 12.5 mm
 - Grille section: 20 x 4 mm
 - 311/1 - 311/2
 - Length floor grille: min. 100 mm - max. 3500 mm
[from 1300 mm multiple grille lengths]
 - Width floor grille: min. 100 mm - max. 1215 mm
 - 311/3:
 - Length frameless floor grille: min. 85 mm - max. 1300 mm
 - Width frameless floor grille: min. 85 mm - max. 1200 mm
- Remark: If the floor grille width > 650 mm, then an underlying support structure must be provided.*
- Effective opening = length and width - 50 mm
 - Bars arranged crosswise

FIXING

- Brackets ref. 231

TYPICAL APPLICATIONS

- Ground heating

TECHNICAL SPECIFICATIONS

All properties are valid for the standard version of the Louvre, unless otherwise stated.

Technical data	
Visual free area	76%
Physical free area	76%

TECHNICAL DRAWINGS

Cross-sections

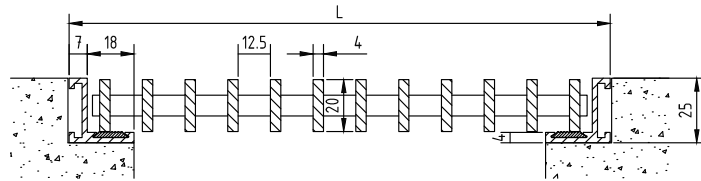

311/1: Floor grille or convector cover with flangeless "L" frame

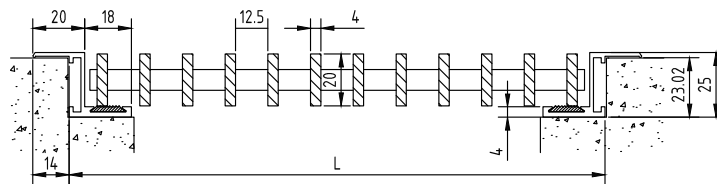

311/2: Floor grille or convector cover with flanged "Z" frame

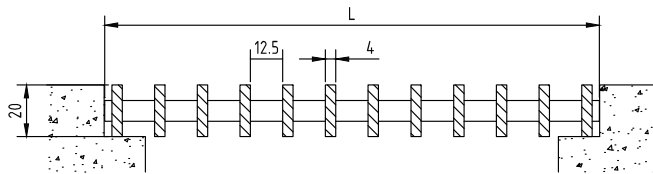

311/3: Frameless floor grille or convector cover

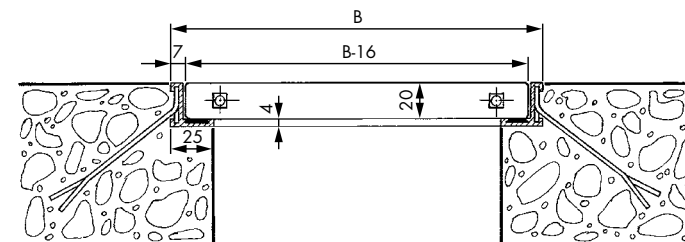

371

AVAILABLE UNTIL END OF STOCK

Floor grille, heavy-duty series

FLOOR GRILLE

ALUMINIUM



MATERIAL

- Made from aluminium sections: AlMgSi 0.5 [according to EN 12020-2]
- Finishing: anodized in satin colour [20 micron] or powder-coated in any RAL or Syntha Pulvin colour [40 micron]
- The frame is lined with a rubber gasket to guarantee a reduced noise level

DIMENSIONS

- Bar spacing: 12.5 mm
- Grille section: 20 x 8 mm
- 371/1 - 371/2
 - Length floor grille: min. 135 mm - max. 3500 mm [from 1200 mm multiple lengths]
 - Width floor grille: min. 135 mm - max. 915 mm

Remark: frame must be fully supported

- 371/3:
 - Length frameless floor grille: min. 120 mm - max. 1200 mm
 - Width frameless floor grille: min. 120mm - max. 900 mm

Remark: If the floor grille width > 650 mm, then an underlying support structure must be provided.

- Effective opening = length and width - 50 mm
- Bars arranged crosswise

FIXING

- Brackets ref. 231

TYPICAL APPLICATIONS

- Grilles for swimming pool drains, cellars, garages, car parks, abattoirs, etc
- To cover underfloor wiring ducts in computer rooms

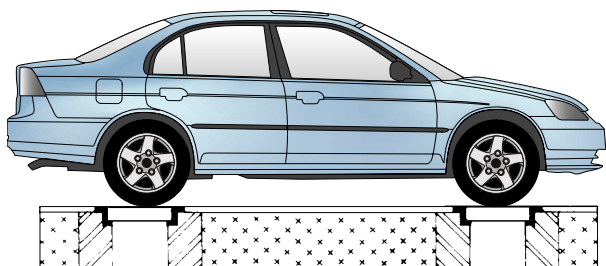

TECHNICAL SPECIFICATIONS

All properties are valid for the standard version of the Louvre, unless otherwise stated.

Technical data	
Visual free area	61%
Physical free area	61%

TECHNICAL DRAWINGS

Cross-sections

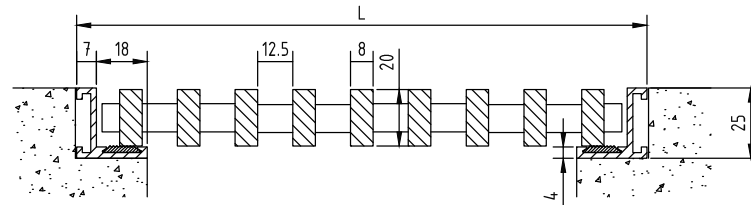

371 / 1: Floor grille with flangeless "L" frame

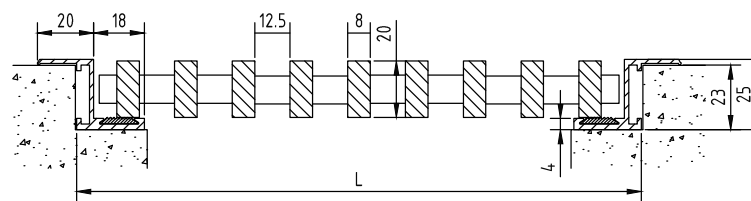

371 / 2: Floor grille with flanged "Z" frame

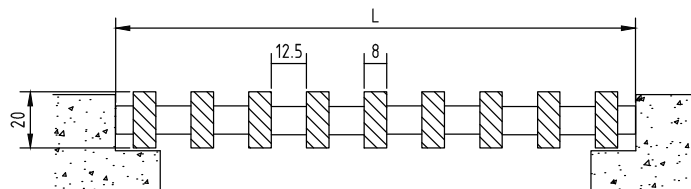

371 / 3: Frameless floor grille

392

Linear bar grille

LINEAR BAR
GRILLE

ALUMINIUM



MATERIAL

- Made from aluminium sections: AlMgSi 0.5 [according to EN 12020-2]
- Finishing: anodized in satin colour [20 micron] or powder-coated in any RAL or Syntha Pulvin colour [40 micron]

Remark: Grille not to be walked on.

DIMENSIONS

- Bar spacing: 10 mm
- Grille section: 16 x 3 mm
- 392/2:
 - Length linear bar grille: min. 130 mm - max. 3500 mm [from 1600 mm multiple grille elements]
 - Width linear bar grille: min. 55 mm - max. 311 mm
- 392/3:
 - Length linear bar grille without frame: min. 120 mm - max. 1600 mm
 - Width linear bar grille without frame: min. 45 mm - max. 300 mm
- Minimum dimensions: 100 x 60 mm
- Effective opening = length and width - 50 mm
- Deflection: 15°
- Bars arranged lengthwise

FIXING

- No fasteners

OPTIONS

- Linear bar grille with flangeless 'L' frame

TYPICAL APPLICATIONS

- Radiator frame

TECHNICAL SPECIFICATIONS

All properties are valid for the standard version of the Louvre, unless otherwise stated.

Airflow		[EN 13030]
K-factor [entry]		5.71
K-factor [discharge]		5.71
C _e coefficient		0.419
C _d coefficient		0.419
Technical data		
Visual free area		76%
Physical free area		76%

TECHNICAL DRAWINGS

Cross-sections

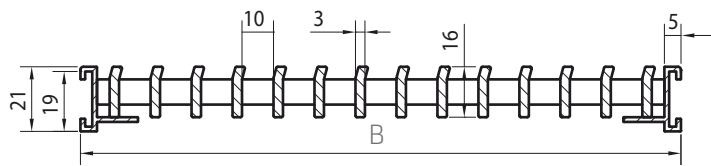

Option: Linear bar grille without flanged "Z" frame

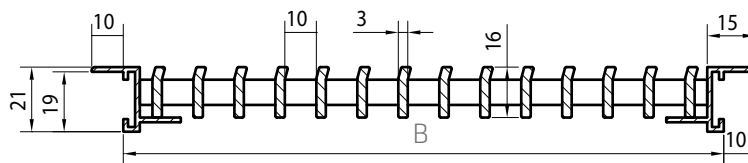

392/2: Linear bar grille with flanged "Z" frame

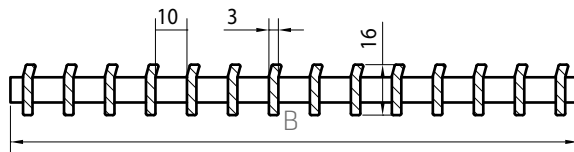

392/3: Frameless linear bar grille

394

Linear bar grille for self-assembly

LINEAR BAR
GRILLE

ALUMINIUM



MATERIAL

- Made from aluminium sections: AlMgSi 0.5 [according to EN 12020-2]
- Finishing: anodized in satin colour [20 micron] or powder-coated in any RAL or Syntha Pulvin colour [40 micron]

Remark: Grille not to be walked on.

DIMENSIONS

- Bar spacing: 9.5 mm
- Section length: 3 or 5.6 metres
- 394/2
 - Length linear bar grille: min. 110 mm - max. 3510 mm
 - Width linear bar grille:
 - Per grille element: min. 55 mm - max. 220 mm
 - Coupled: max. 1055 mm
- 394/3:
 - Length linear bar grille without frame: min. 100 mm - max. 3500 mm
 - Width linear bar grille without frame:
 - Per grille element: min. 45 mm - max. 209 mm
 - Coupled: max. 1045 mm
- Clip length: 209 mm
- Bars arranged lengthwise

FIXING

- No fasteners

NUMBER OF CLIP SECTIONS/LENGTH

- 300 - 500 mm: 2 pieces
- 501 - 900 mm: 3 pieces
- 901 - 1300 mm: 4 pieces
- 1301 - 1700 mm: 5 pieces
- 1701 - 2100 mm: 6 pieces
- 2101 - 2600 mm: 7 pieces
- 2601 - 3000 mm: 8 pieces

ELEMENTS

- Simple clip assembly

TYPICAL APPLICATIONS

- Counters, radiator frame

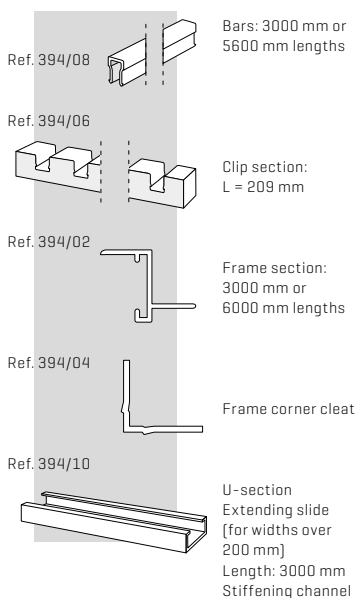

TECHNICAL SPECIFICATIONS

All properties are valid for the standard version of the Louvre, unless otherwise stated.

Technical data	
Visual free area	59%
Physical free area	59%



TECHNICAL DRAWINGS

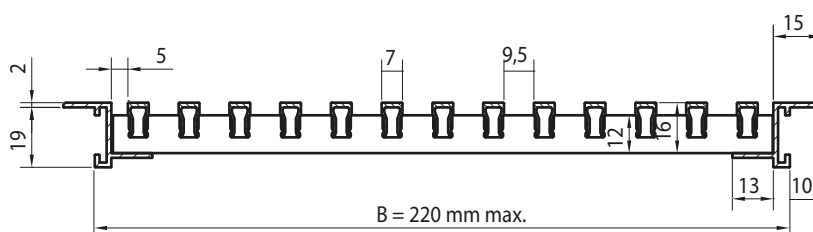

394/2: linear bar grille with flanged 'Z' frame

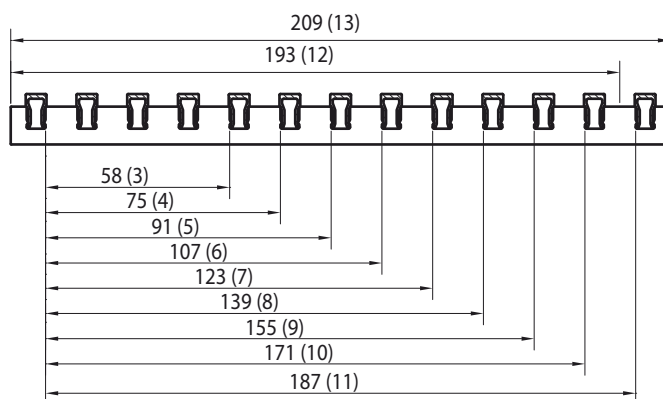

394/3: flangeless linear bar grille

Cross-sections

461

Door grille

DOOR GRILLE

ALUMINIUM



MATERIAL

- Made from aluminium sections: AlMgSi 0.5 [according to EN 12020-2]
- Finishing: anodized in satin colour [20 micron] or powder-coated in any RAL or Syntha Pulvin colour [40 micron]
- Opaque grille with backframe and fixing screws

DIMENSIONS

- Blade pitch: 20 mm
- Door thickness: 30 to 54 mm
- Maximum width [in one piece]: 800 mm
- Minimum height: 76 mm

OPTIONS

- Controllable version [type 463] on request
- Frame for 55 to 80 mm thickness

FIXING

- Screws are included

STOCK MODELS

Dimensions (W x H) mm	Natural-coloured anodised	Renson Standard WHITE	RAL 8019	Airflow at 2 Pa (m ² /h)	Airflow at 20 Pa (m ² /h)	Visual free area	Physical free area
200 x 100	00046121			19.3	61.1	93%	39%
400 x 200	00046142	00461426	00461427	83.8	264.9		
400 x 300	00046143			127.9	404.3		
500 x 300	00046153			160.7	508.0		
600 x 400	00046164			260.1	822.6		
425 x 76	00004611	00004616	00004615	31.0	97.9		



TECHNICAL SPECIFICATIONS

All properties are valid for the standard version of the Louvre, unless otherwise stated.

Technical data	
Visual free area	93%
Physical free area	39%



TECHNICAL DRAWINGS

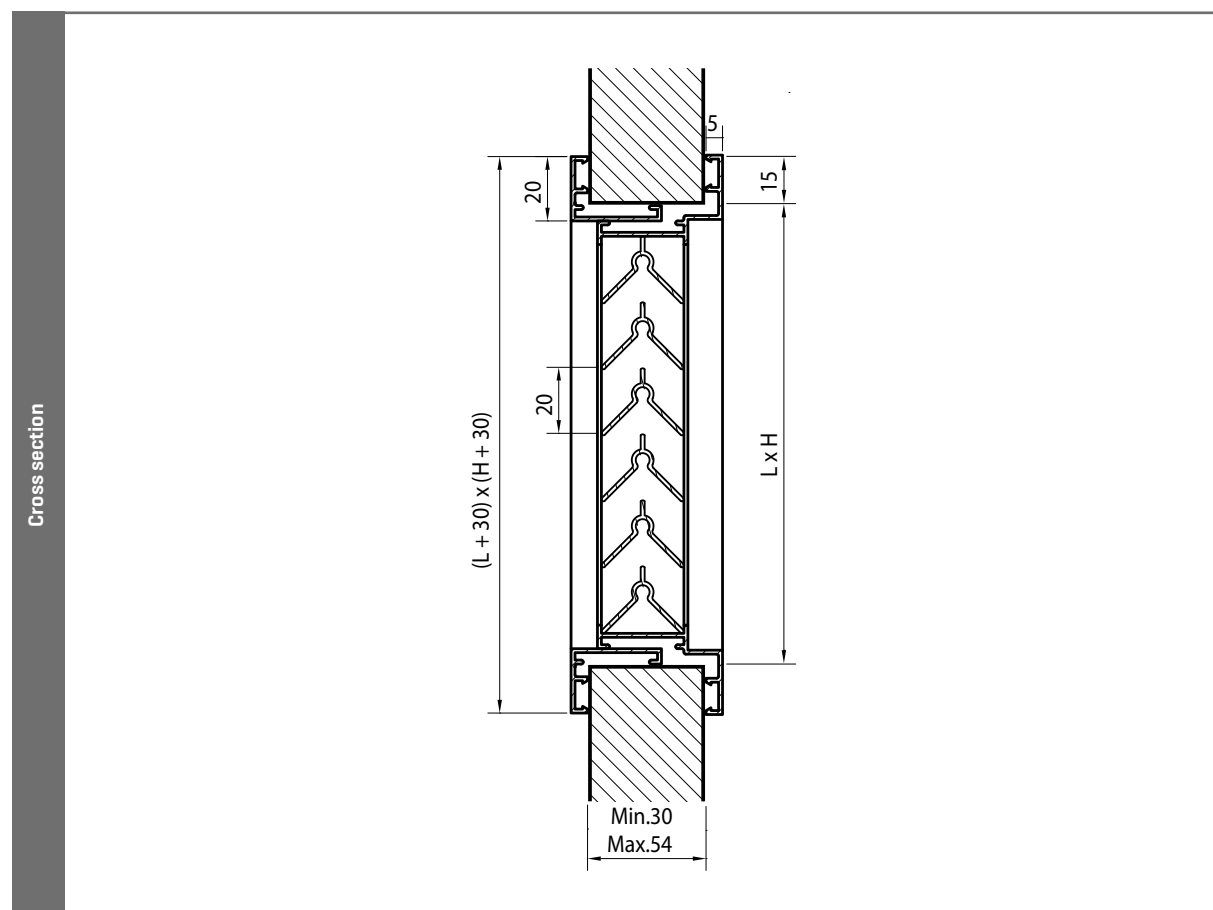

468AK/1

Interior acoustic door grille

DOOR GRILLE

ALUMINIUM



MATERIAL

- Made from aluminium sections: AlMgSi 0.5 [according to EN 12020-2]
- Finishing: anodized in satin colour [20 micron] or powder-coated in any RAL or Syntha Pulvin colour [40 micron]
- Sound absorbing material: synthetic foam
- Labyrinth type blades

DIMENSIONS

- Minimum dimensions: 200 x 180 mm
- Maximum dimensions: 800 x 775 mm
- Height in 85 mm steps [blade pitch]
- Depth to fit: 48 mm
- Flange size: 30 mm

OPTIONS

- Backframe 468 AK/2 [see p. 142]

TYPICAL APPLICATIONS

- Schools
- Hospitals
- Elderly homes

Remark: for internal use only!



TECHNICAL SPECIFICATIONS

All properties are valid for the standard version of the Louvre, unless otherwise stated.

Airflow		[EN 13030]	[EN ISO 140-10, EN ISO 717-1]
K-factor [entry]		86.85	
K-factor [discharge]		89.35	$R_w [C;C_v]: 8 [-1;-2]$ dB
C_e coefficient		0.107	
C_d coefficient		0.106	
Dimensions [W x H]	[EN 130141-1]	Airflow at 2 Pa in m³/h	Sound reduction $D_{n,e,w} [C;C_v]$
Q at 2 Pa - grille 292 x 180 mm		25 m ³ /h	30 [-1;-2] dB
Q at 2 Pa - grille 382 x 265 mm		50 m ³ /h	28 [-1;-2] dB
Q at 2 Pa - grille 432 x 350 mm		75 m ³ /h	26 [-1;-2] dB
Q at 2 Pa - grille 452 x 435 mm		100 m ³ /h	25 [-1;-2] dB
Technical data			
Visual free area		29%	
Physical free area		29%	
IP class [louvre with mesh]		IP2XD	

TECHNICAL DRAWINGS

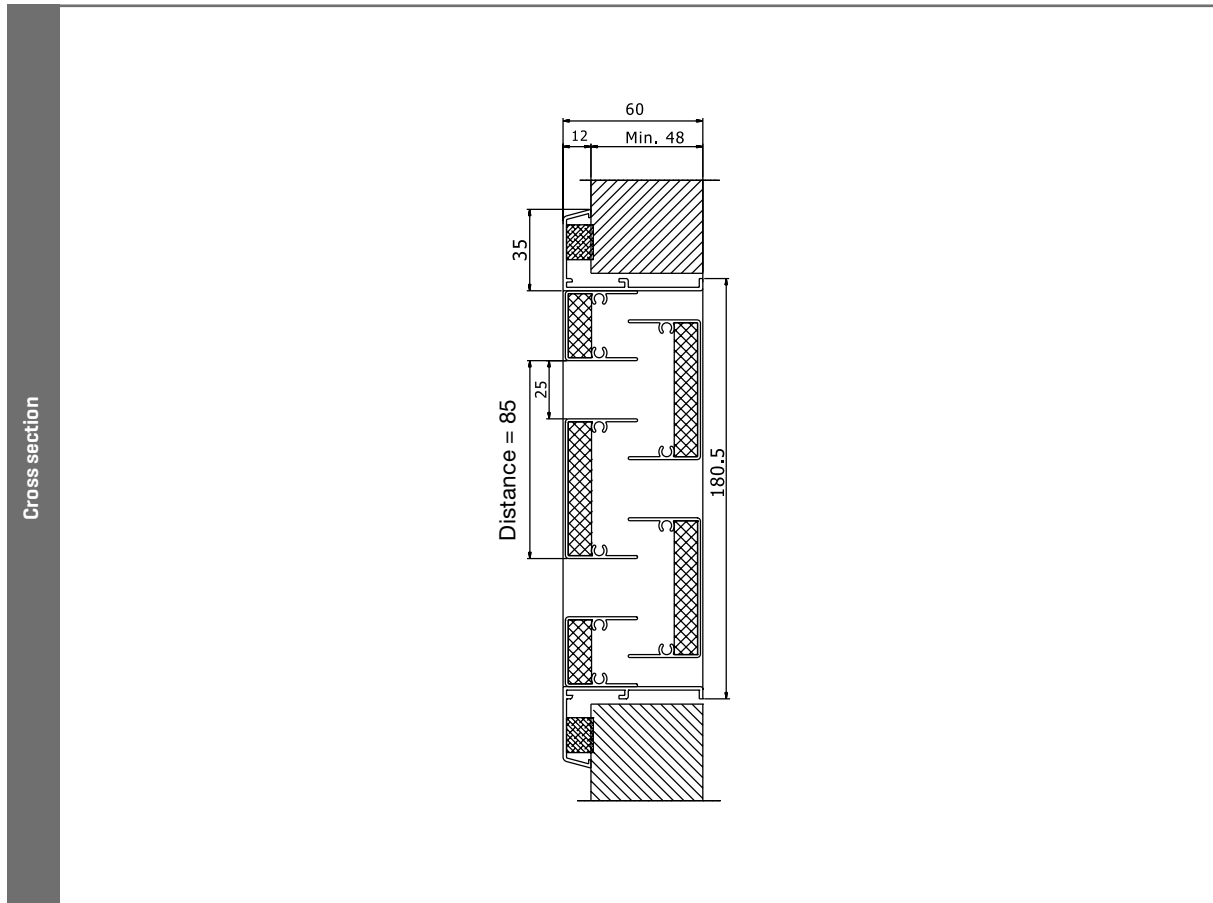

468AK/2

Interior acoustic door grille

DOOR GRILLE

ALUMINIUM



MATERIAL

- Made from aluminium sections: AlMgSi 0.5 [according to EN 12020-2]
- Finishing: anodized in satin colour [20 micron] or powder-coated in any RAL or Syntha Pulvin colour [40 micron]
- Sound absorbing material: synthetic foam

DIMENSIONS

- Minimum dimensions: 200 x 193 mm H
- Maximum dimensions: 800 x 788 mm H
- Height in 85 mm steps [blade pitch]
- Door thickness: from 37.5 to 92 mm

AVAILABLE MODELS

- The 468 AK/2 is available in Renson® standard WHITE in the following standard sizes: 292 x 193 mm, 382 x 278 mm, 432 x 363 mm and 452 x 448 mm
- Other sizes and colours available on request

FIXING

- Screws included

TYPICAL APPLICATIONS

- Schools, dressing rooms, garagedoors, central heating system rooms, hospitals

Remark: for internal use only!



TECHNICAL SPECIFICATIONS

All properties are valid for the standard version of the Louvre, unless otherwise stated.

Airflow		[EN 13030]	[EN ISO 140-10, EN ISO 717-1]
K-factor [entry]		86.85	
K-factor [discharge]		89.35	$R_w [C;C_v]: 8 [-1;-2]$ dB
C_e coefficient		0.107	
C_d coefficient		0.106	
Dimensions [W x H]	[EN 130141-1]	Airflow at 2 Pa in m³/h	Sound reduction $D_{n,e,w} [C;C_v]$
Q at 2 Pa - grille 292 x 193 mm		25 m ³ /h	30 [-1;-2] dB
Q at 2 Pa - grille 382 x 278 mm		50 m ³ /h	28 [-1;-2] dB
Q at 2 Pa - grille 432 x 363 mm		75 m ³ /h	26 [-1;-2] dB
Q at 2 Pa - grille 452 x 448 mm		100 m ³ /h	25 [-1;-2] dB
Technical data			
Visual free area		29%	
Physical free area		29%	
IP class [louvre with mesh]		IP2XD	

TECHNICAL DRAWINGS

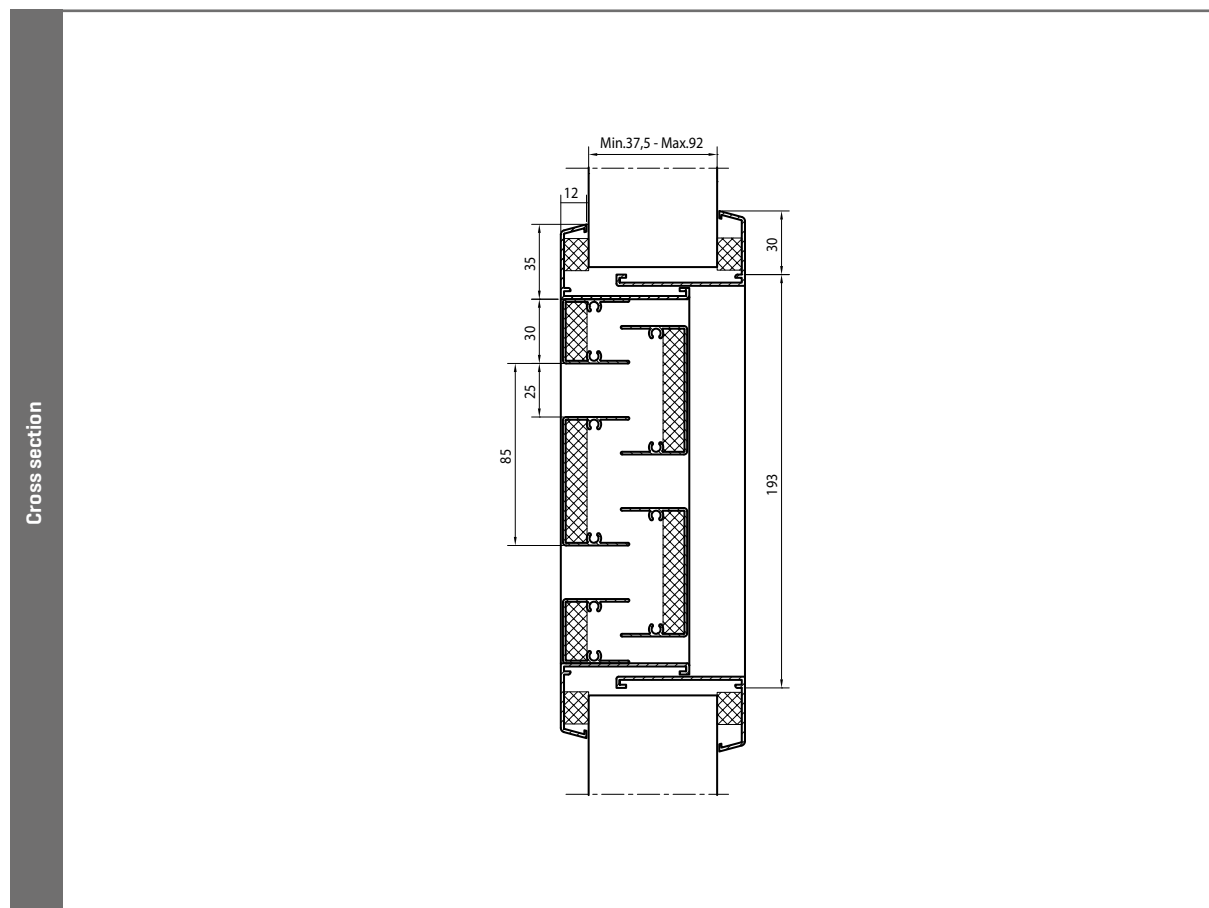

461 AK SILENDO®

Acoustic door grille for residential sector

DOOR GRILLE

ALUMINIUM



MATERIAL

- Sound absorbing material: synthetic foam
- End caps: in Luran S ASA polymer (colourfast, weatherproof and UV resistant)
- End caps: available in grey, black or white

DIMENSIONS

- Length: 425 mm
- Height: 48 mm
- Door thickness: min. 37 mm - max. 43 mm

FIXING

- Click system

TECHNICAL SPECIFICATIONS

All properties are valid for the standard version of the Louvre, unless otherwise stated.

Airflow		[EN 13141-1]
Q at 1 Pa		17.7 m ³ /h
Q at 2 Pa		25.1 m ³ /h
Q at 10 Pa		56.1 m ³ /h
Q at 20 Pa		79.4 m ³ /h
Comfort		[EN ISO 140-10, EN ISO 717-1]
Sound reduction $D_{n,e,w}$ [C;C _v]		32 [0;-2] dB
Technical data		
Visual free area		27%
Physical free area		27%
Colours		[EN 13501-2]
Natural-coloured anodised		01046111
Renson Standard WHITE		01046116
RAL 8019		01046117

TECHNICAL DRAWINGS

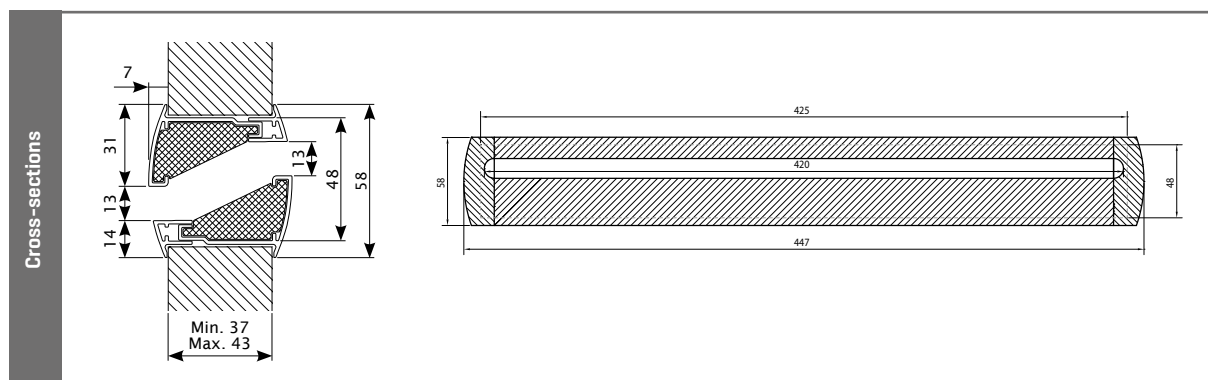



Door grille 461 [see p. 142]

469 - INVISIDO®

Discreet door grille

DOOR GRILLE

ALUMINIUM



MATERIAL

- Endcaps: in Luran S ASA polymer (true colour, weather and UV resistant)
- Endcaps are available in black, grey, cream, or white; other colours available upon request

DIMENSIONS

- Maximum length: 2000 mm
- Standard dimensions: 725 mm [type 730], 825 mm [type 830], 925 mm [type 930]
- Door thickness: starting at 35 mm

FIXING

- Screws included

TECHNICAL SPECIFICATIONS

Invisido® 469 [type 830]

All properties are valid for the standard version of the Louvre, unless otherwise stated.

Airflow		[EN 13141-1]		
Q at 1 Pa		17.6 m³/h [4.9 dm³/s]		
Q at 2 Pa		25.3 m³/h		
Q at 10 Pa		58.8 m³/h		
Q at 20 Pa		84.7 m³/h		
Comfort		[EN ISO 140-10, EN ISO 717-1]		
Sound reduction $D_{n,e,w}$ [C;C _r]		28 [-1;0] dB		
Dimensions [L]	Natural colour	Renson Standard WHITE	RAL 9005	RAL 1015
725	46973001	46973002	46973003	46973004
825	46983001	46983002	46983003	46983004
925	46993001	46993002	46993003	46993004

Other colours available upon request



TECHNICAL DRAWINGS

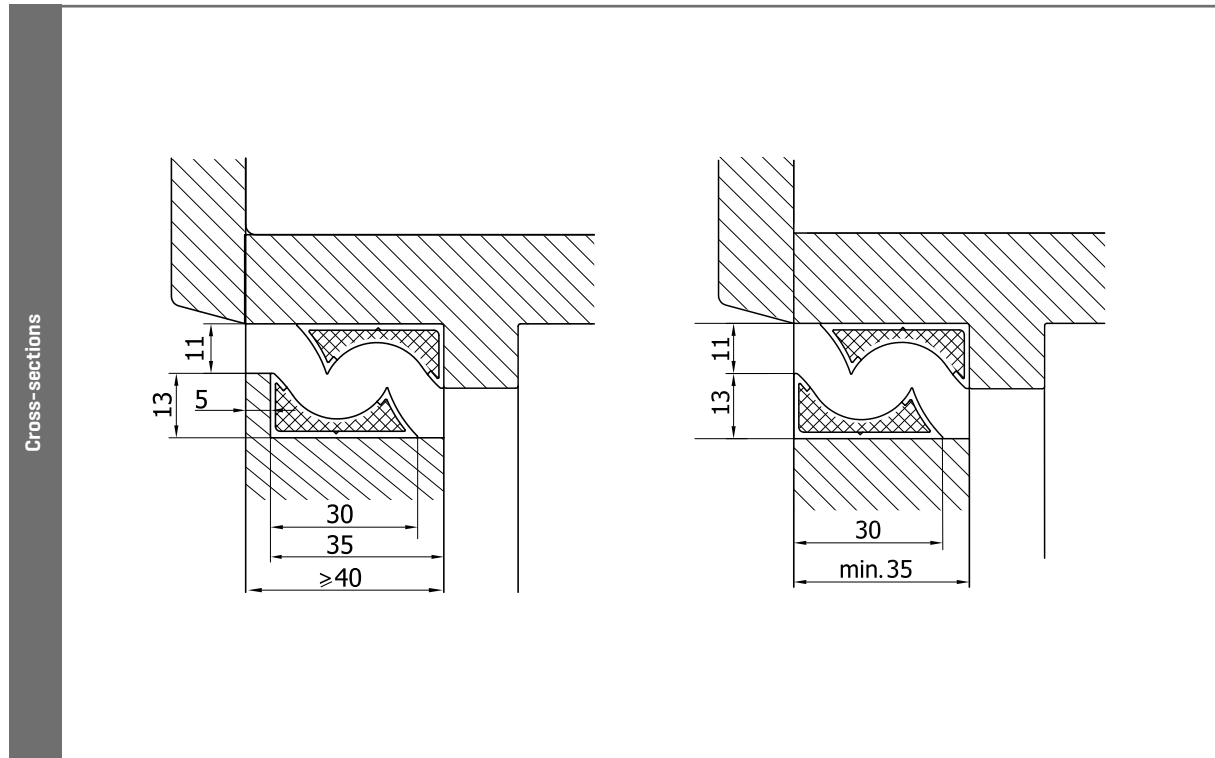

INCENDO® 464

Fire-resistant louvre with angled blades, fire-resistance 60 minutes

FIRE-RESIS-
TANT LOUVRE



MATERIAL

- Blades filled with intumescent material
- Outer frame in Polystyrene
- Available in RAL 7024 (anthracite grey), RAL 9016 (traffic white) and RAL 9022 (pearl light grey)

DIMENSIONS

- Built-in depth: 40 mm min.
- Blade pitch: 20 mm
- Maximum dimension: 800 x 400 mm
- Minimum dimensions: 100 x 100 mm
- 464/1: with frame, 464/2: with frame and adjustable counterframe

FIXING

- With sealant and adhesive neoprene mastic

TYPICAL APPLICATIONS

- Aesthetic finish, no visible vertical posts
- Tested according to EN1634-1, EN1364-1 and EN1364-2
- Fire resistance EI 60 (Integrity and thermal insulation for 1 hour) according to EN13501-2
- Suitable for installation in a wooden door panel, flexible wall, massive wall, floor or ceiling
- No visual see through

Remark: avoid contact with water, for indoor use only

TECHNICAL SPECIFICATIONS

All properties are valid for the standard version of the Louvre, unless otherwise stated.

Airflow		[EN 13030]
K-factor [entry]		10.27
K-factor [discharge]		10.27
C _e coefficient		0.312
C _d coefficient		0.312
Technical data		
Visual free area		61%
Physical free area		51%
IP class		IP2XD
Fire classification		[EN 13501-2]
Large wall area [100 mm]		EI 60 / EW 90 [ve i<->o]
Large floor area [100 mm]		EI 60 [ho i<->o]
Flexible wall [metal stud gypsum plasterboard 100 mm]		EI 60 [ve i<->o]
[Wooden] doorpanel [50 mm]		EI 60 / EW 60 [ve i<->o]
[Wooden] doorpanel [40 mm]		EI 30 / EW 30 [ve i<->o]

TECHNICAL DRAWINGS

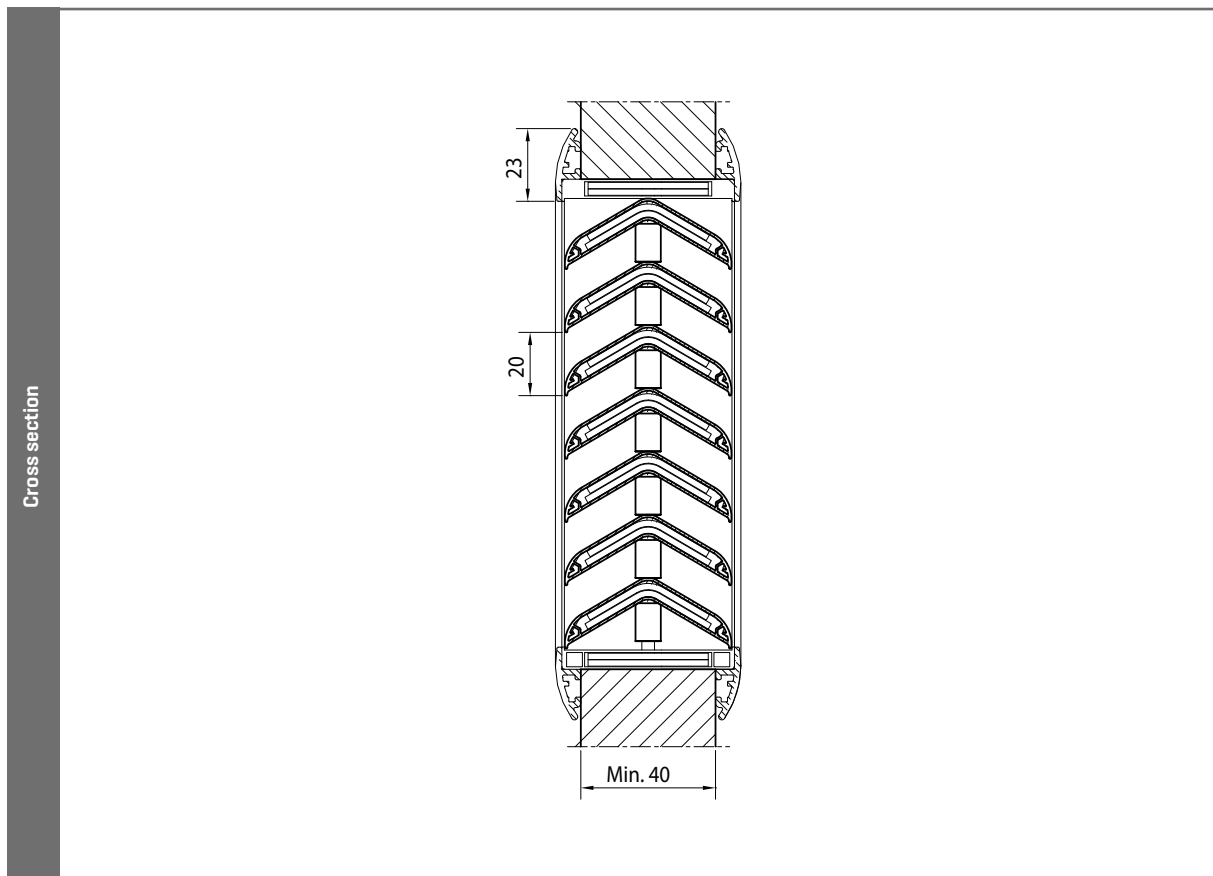

465

AVAILABLE UNTIL END OF STOCK

Fire-resistant louvre with angled blades, fire-resistance 60 minutes

FIRE-RESIS-
TANT LOUVRE



MATERIAL

- Blades filled with intumescent materials (PALUSOL)
- Protection by grey-coloured synthetic sheath
- Outer frame in satin anodised aluminium [20 microns]
- Other frame colours on request.

DIMENSIONS

- Maximum dimensions: 600 x 300 mm
- Special dimensions on request
- 465/2: door thickness min. 45 mm - max. 55 mm

PURPOSE

- Ventilation between two adjacent rooms
- In case of fire, cuts off the airflow and creates a firebreak function

APPLICATIONS

- Fire-resistant constructions
- Fire-resistant conduit
- Fire doors

Remark: for indoor use only, avoid contact with water

FUNCTION

- At a temperature of 120°C, the blades swell to close the vent
- Forms a static fire valve for 60 minutes

FIXING

- Secure the louvre in the opening
- Fill the gap between the louvre and the door/wall with fire-resistant mortar

OPTION

- Frame for 55 to 80 mm thickness

TYPICAL APPLICATIONS

- Fire door apartments

STOCK MODELS

Dimensions (W x H) mm	465/1 (with frame)	465/2 (with frame and backframe)	Airflow at 2 Pa (m ² /h)
200 x 200	00465122		82
300 x 300	00465133		185
400 x 200	00465142	00465242	164
500 x 200	00465152		205

TECHNICAL SPECIFICATIONS

All properties are valid for the standard version of the Louvre, unless otherwise stated.

Fire resistance	1 hour Rf
Test report available upon request	
Technical data	
Visual free area	74%
Physical free area	57%

TECHNICAL DRAWINGS

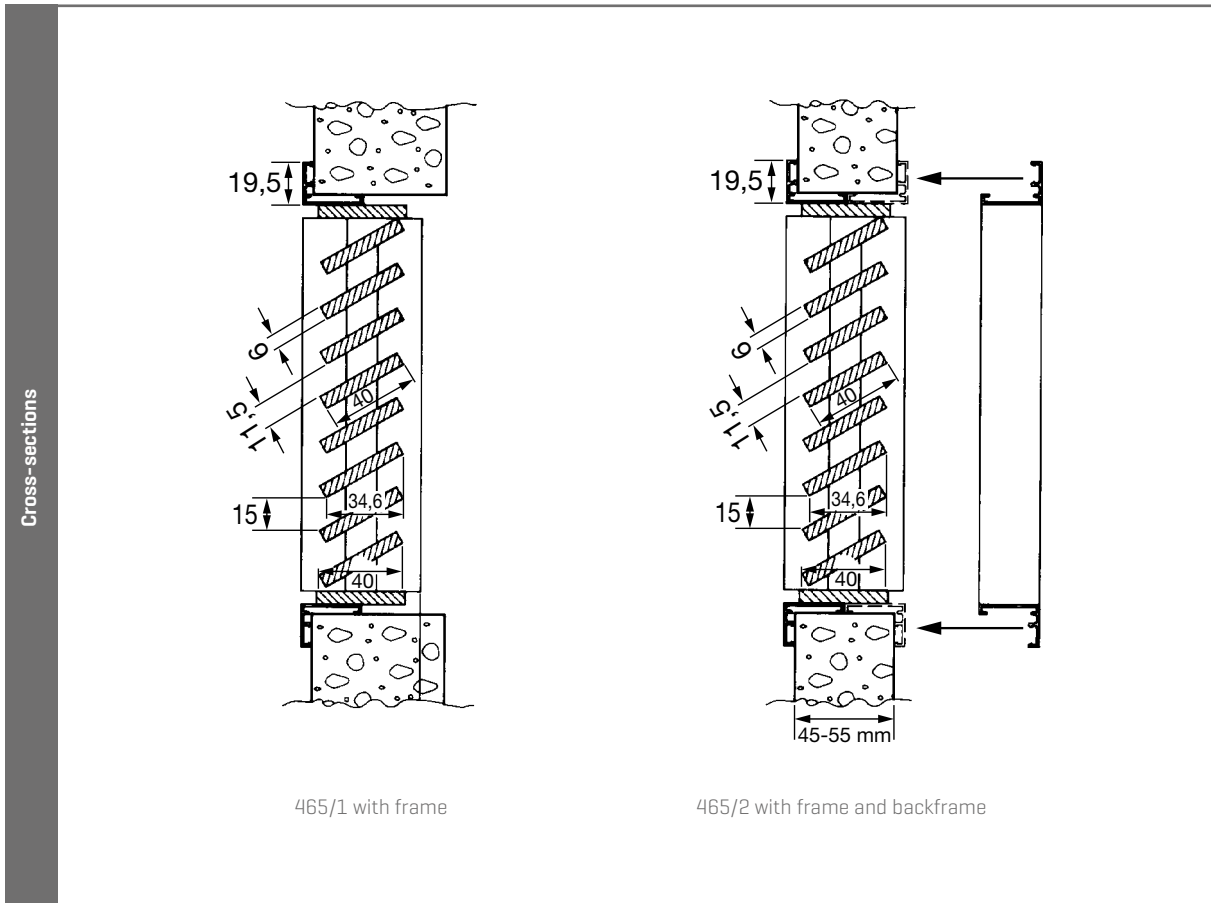

465/1 with frame

465/2 with frame and backframe

466

AVAILABLE UNTIL END OF STOCK

Fire-resistant louvre with horizontal blades

FIRE-RESIS-
TANT LOUVRE



MATERIAL

- Blades filled with intumescent materials (PALUSOL)
- Protection by grey-coloured synthetic sheath
- Outer frame in satin anodised aluminium [20 microns]
- Other frame colours on request.

DIMENSIONS

- Maximum dimensions: 600 x 400 mm
- Dimensions on request
- 466/2: door thickness min. 45 mm - max. 55 mm

PURPOSE

- At normal temperature, guarantees ventilation between two adjacent rooms
- In case of fire, cuts off the airflow and creates a firebreak function

APPLICATIONS

- Fire-resistant constructions
- Fire-resistant conduit
- Fire doors

Remark: for indoor use only, avoid contact with water

FUNCTION

- At a temperature of 120°C, the blades swell to close the vent
- Forms a static fire valve for 60 minutes

FIXING

- Secure the louvre in the opening
- Fill the gap between the louvre and the door/wall with fire-resistant mortar

OPTION

- Frame for 55 to 80 mm thickness

TECHNICAL SPECIFICATIONS

All properties are valid for the standard version of the Louvre, unless otherwise stated.

Fire resistance	1 hour Rf
Test report available upon request	
Technical data	
Visual free area	70%
Physical free area	70%

TECHNICAL DRAWINGS

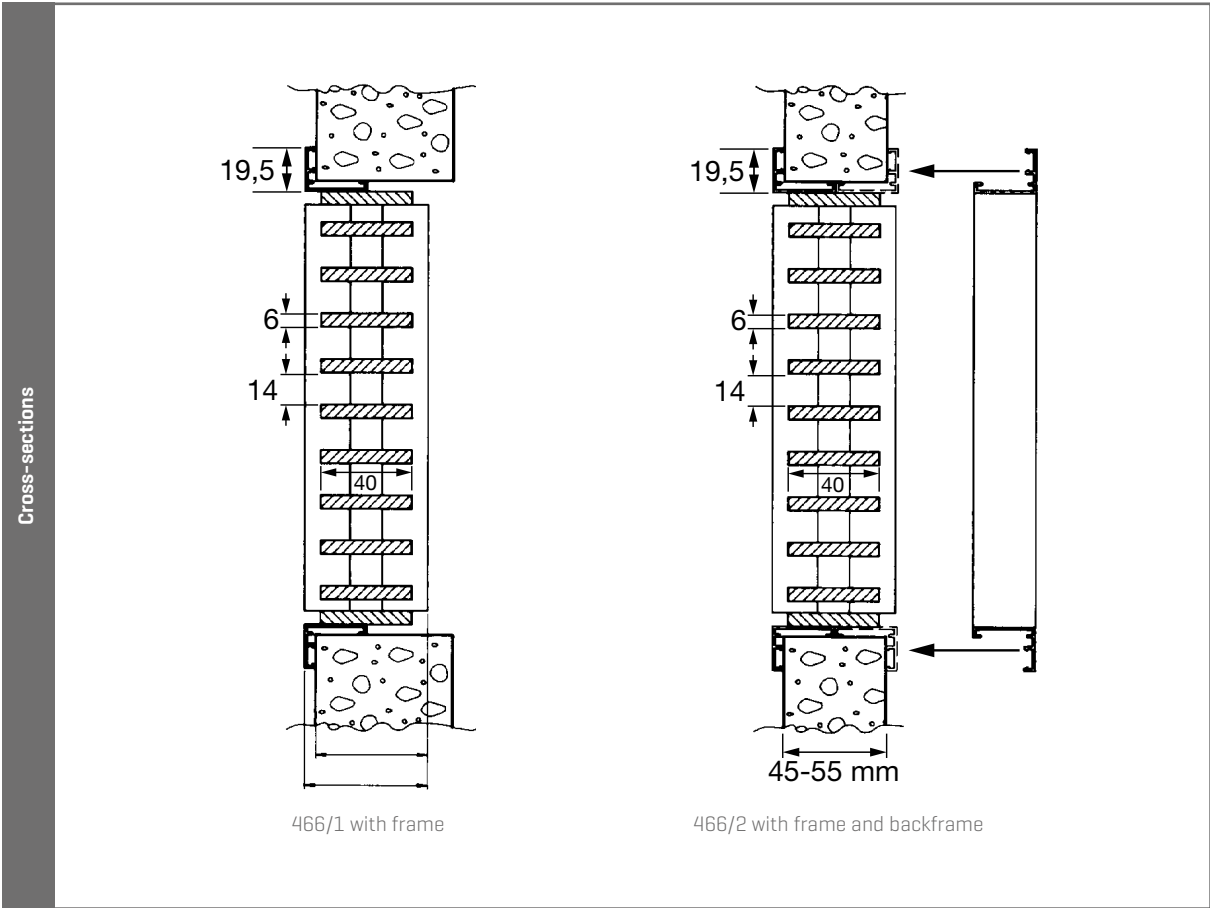

467

Fire-resistant louvre with horizontal blades, in solid concrete wall

FIRE-RESIS-
TANT LOUVRE



MATERIAL

- Horizontal blades with plastic housing, filled with intumescent material (PALUSOL)
- Outer frame in HDF
- Colour: grey

DIMENSIONS

- Depth to fit: 100 mm
- Blade pitch: 18 mm
- Minimum dimensions W x H: 150 x 100 mm
- Maximum dimensions W x H: 1200 x 800 mm

TARGET

- At normal temperature, guarantees ventilation between two adjacent rooms
- In case of fire, cuts off the airflow and creates a firebreak function

APPLICATIONS

- The intumescence of the blades cuts everything off as from 100°C.
- The louvre acts as a static fire damper for 120 minutes.

TESTED ACCORDING TO EN 1364-1

INSTALLATION

- In solid wall (aerated concrete ≥ 100 mm)
- Secure/seal louvre using plaster/Ytocol

TYPICAL APPLICATIONS

- Fire-resistant constructions

Note: not for outdoor use; avoid contact with water.

TECHNICAL SPECIFICATIONS

All properties are valid for the standard version of the Louvre, unless otherwise stated.

Airflow		[EN 13030]
K-factor [entry]		4.16
K-factor [discharge]		4.06
C _e coefficient		0.490
C _d coefficient		0.496
Technical data		
Visual free area		66.7%
Physical free area		66.7%
Fire classification		[EN 13501-2]
Solid concrete wall (≥ 100 mm)		EI 120 (ve i<->o)

TECHNICAL DRAWINGS

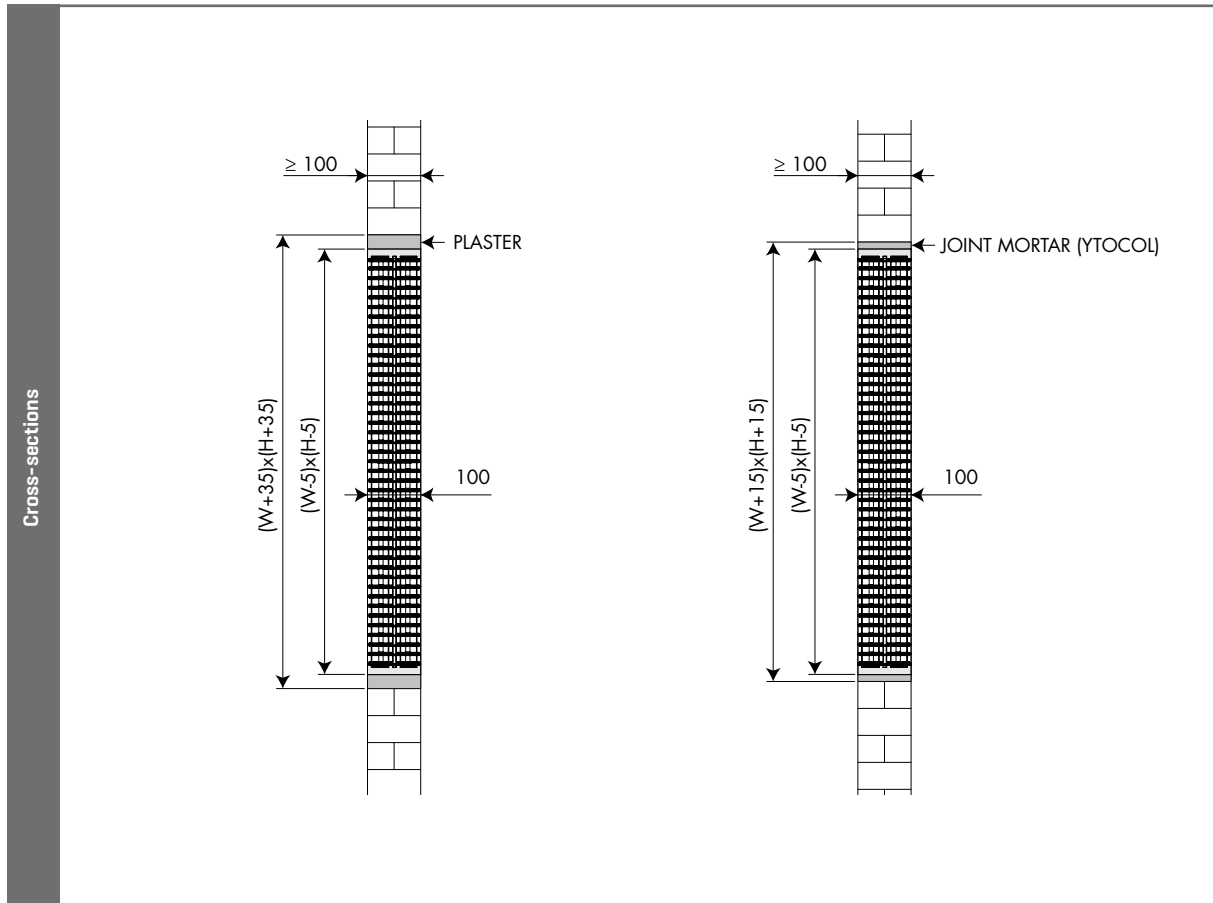

442

AVAILABLE UNTIL END OF STOCK

Controllable cavity wall louvres

HIT AND MISS
LOUVRE

ALUMINIUM



442 - Cavity wall ventilator

MATERIAL

- Made from aluminium sections: AlMgSi 0.5 [according to EN 12020-2]
- Stainless steel 304 insect screen [2.3 x 2.3 mm]
- Finishing: anodized in satin colour [20 micron] or powder-coated in any RAL or Syntha Pulvin colour [40 micron]
- Connecting sleeve made from galvanised steel

DIMENSIONS

- Size to fit: 265 x 90 mm [L x H]
- Flange size: 21 mm
- Controllable internal louvre
- Adjustable sleeve for wall thickness of 245 till 400 mm

OPTIONS

- Optional sound absorbing material

FIXING

- Spring clips are included

STOCK MODELS

Dimensions (W x H) mm	Natural colour anodised	Renson Standard WHITE	Airway opening in cm ²	Airflow at 2 Pa [m ³ /h]	Airflow at 20 Pa [m ³ /h]
265 x 90	00044211	00044216	38	15	49.4

TECHNICAL DRAWINGS

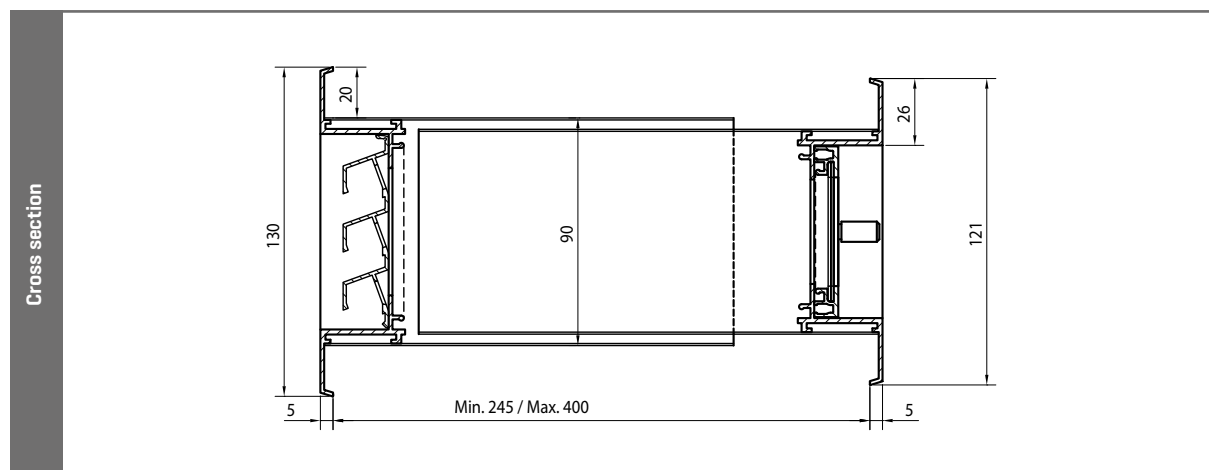

441

Controllable cavity wall louvres

441 - Controllable cavity wall louvres Register with frame

MATERIAL

- Made from aluminium sections: AlMgSi 0.5 [according to EN 12020-2]
- Stainless steel 304 insect screen [2.3 x 2.3 mm]
- Finishing: anodized in satin colour [20 micron] or powder-coated in any RAL or Syntha Pulvin colour [40 micron]

DIMENSIONS

- Depth to fit: 28.5 mm
- Flange size: 21 mm
- Rotating knob for louvre lengths of 500 mm and above [possibility of pull-cord or rod operation]

CUSTOMISATION

- Maximum dimensions w x h: 3000 mm x 1074 mm or 1074 mm x 3000 mm
- Possible dimensions w x h: upon request

FIXING

- Spring clips available on request

STOCK MODELS

Available until end of stock – after that, only available as custom product.

Dimensions (W x H) mm	Natural colour anodised	Renson Standard WHITE	Airway opening in cm ²	Airflow at 2 Pa (m ³ /h)
217 x 212	00000441	00004416	113	45
248 x 212	00044111		140	63.1
307 x 312	00000442	00004426	260	114.7



TECHNICAL DRAWINGS

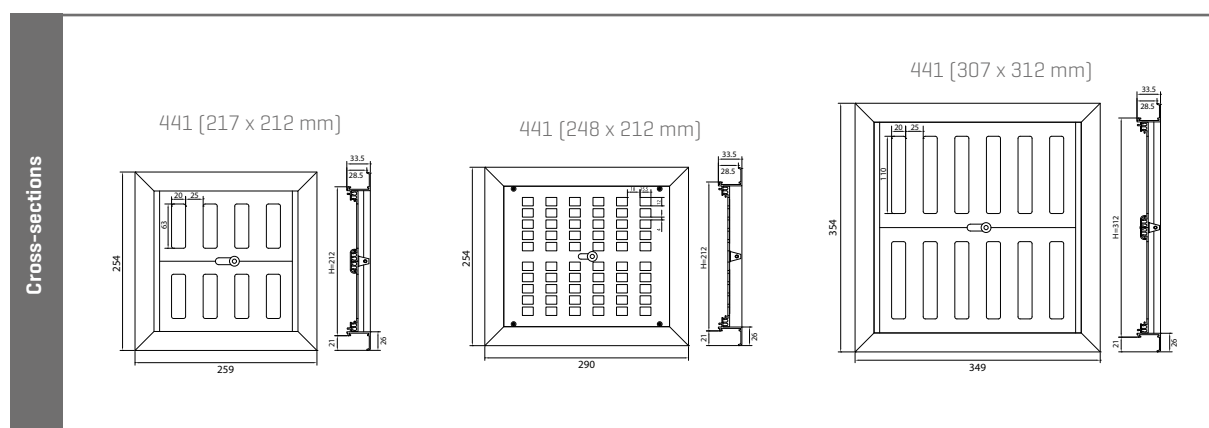

4032

Controllable cavity wall louvres

HIT AND MISS
LOUVRE

ALUMINIUM



4032 - Controllable cavity wall louvres. Register to fix.

MATERIAL

- Made from aluminium sections: AlMgSi 0.5 [according to EN 12020-2]
- Stainless steel 304 insect screen [2.3 x 2.3 mm]
- Finishing: anodized in satin colour [20 micron] or powder-coated in any RAL or Syntha Pulvin colour [40 micron]

CONTROL

- Slide knob control
- Rotating knob for louvre lengths of 500 mm and above [possibility of pull-cord operation]

DIMENSIONS

- Standard dimensions : see table stock models
- Made to measure :
 - maximal width : 2000 mm
 - height : on request [The louvre height must fit within 100, 130 or 150 mm modules.]
 - maximal height 1500 mm

FIXING

- Screws and plugs are included

STOCK MODELS

Dimensions (W x H) mm	Natural colour anodised	Renson Standard WHITE	Airway opening in cm ²	Airflow at 2 Pa (m ³ /h)
4032/1: 175 x 150	00403211	00403216	49	22.1
4032/2: 240 x 200	00403221	00403226	113	51.0

Available until end of stock:

Dimensions (W x H) mm	Natural colour anodised	Renson Standard WHITE	Airway opening in cm ²	Airflow at 2 Pa (m ³ /h)
4032/4: 300 x 100	00403241	00403246	68	30,0
4032/5: 450 x 100	00403251	00403256	113	49,9

TECHNICAL DRAWINGS

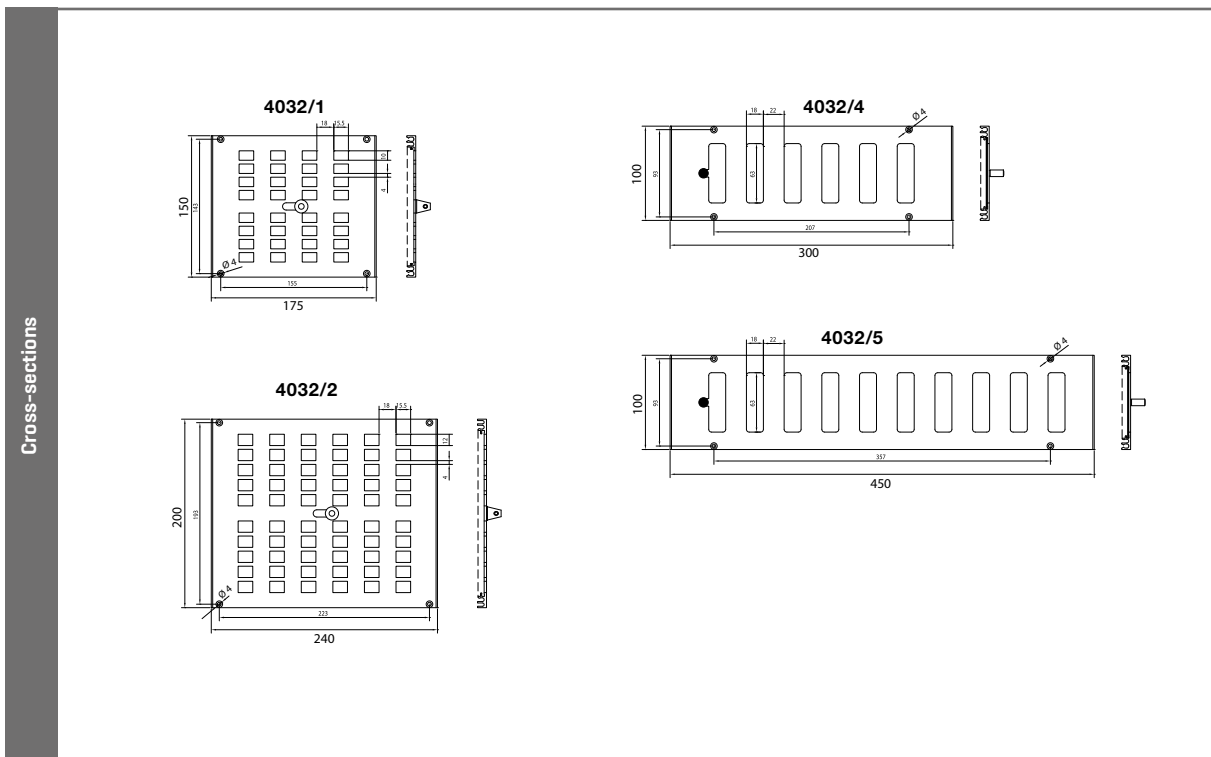

XD

Design extraction louvre

AVAILABLE UNTIL END OF STOCK

HIT AND MISS
LOUVRE

DESIGN

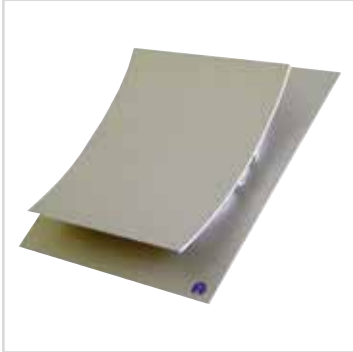

MATERIAL

- Cover plate: aluminium AlMgSi 0.5 [according to EN 12020-2]
- Finishing: powder coating in any RAL or Syntha Pulvin® colour (40 microns)
- Base and sliding part: POM [polyoxymethylene]

DIMENSIONS

- XD1: 152 x 152 mm
- XD2: 188 x 188 mm
- XD3: 233 x 233 mm
- Depth [in closed position]: 79 mm

TYPICAL APPLICATIONS

- Aesthetical internal louvre for wall or ceiling



TECHNICAL SPECIFICATIONS

All properties are valid for the standard version of the Louvre, unless otherwise stated.

	XD1	XD2	XD3
Dimensions [mm]	152 x 152 depth: 79 [closed]	188 x 188 depth: 79 [closed]	233 x 233 depth: 79 [closed]
Use	System C All wet rooms	System A Toilet Closed area ≤ 14 m ²	System A Openspace kitchen Close area ≤ 14 m ²
Airflow [EN 13141-1]	Position I: not possible Position II: 22 m ³ /h at 2 Pa	Position I: 39.2 m ³ /h at 2 Pa Position II: 50.4 m ³ /h at 2 Pa	Position I: 63.0 m ³ /h at 2 Pa Position II: 87.1 m ³ /h at 2 Pa
Duct diameter	80 mm (max. ø 140 mm)	100 mm, 140 mm (max. ø 160 mm)	140 mm, 170 mm (max. ø 200 mm)
Colours			
RAL 9006	66015202	66018802	66023302
Renson Standard WHITE	66015205	66018805	66023305

[Other colours available upon request]

TECHNICAL DRAWINGS

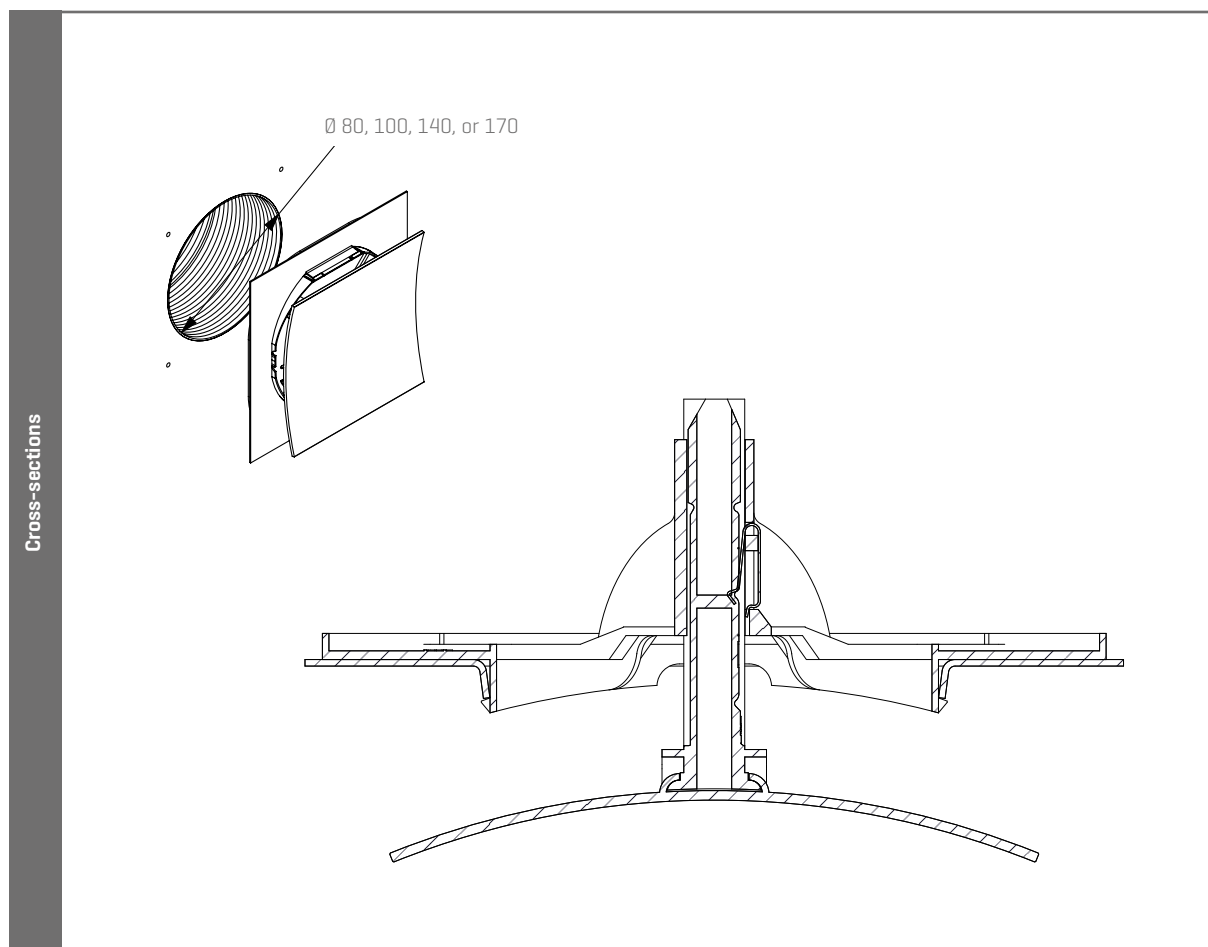

SQair

Extractor vent

DESIGN

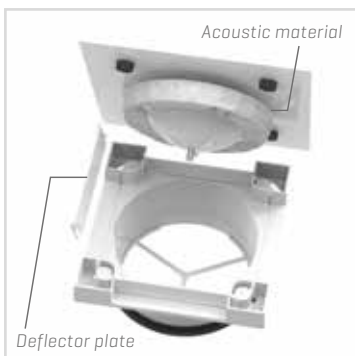

ADJUSTABLE VENT IN 4 MODELS

- Extractor vent:
 - Deluxe: aluminium front plate (painted RAL 9010)
 - Basic: plastic front plate RAL 9010 (in full)
- Pulse vent:
 - Deluxe: aluminium front plate (painted RAL 9010)
 - Basic: plastic front plate RAL 9010 (in full)

SURFACE MOUNTING

- Louver base + front plate

ONLY PROTRUDES 241 MM COMPARED TO THE WALL OR CEILING

- Broader front plate discretely covers the vent opening

DIRECT CONNECTION TO THE AIR DUCT SYSTEM

- Ø 125 mm
- Integrated rubber seal air-tight connection

FRONT PLATE

- Deluxe: attached to the louvre base using magnets
- Basic: clicks into the louvre base
- Easy disassembly for cleaning
- Thanks to the lock nut, the settings for the vent are maintained during cleaning

PULSE VENT IS FITTED WITH ACOUSTIC MATERIAL

- Prevents distorted sound at the vent

DELUXE PULSE VENT IS FITTED WITH 2 DEFLECTOR PLATES

- Two of the four vent openings can be closed using deflector plates
E.g.: if the vent is placed close to a wall, then this side can be closed off to prevent transfer of dirt/dust (will impact the airflow)

PACKAGING

- ART. no.:
 - 76050400 Deluxe pulse
 - 76050403 Basic pulse
 - 76050401 Deluxe extraction
 - 76050404 Basic extraction
- Dimensions: 200 x 190 x 85 mm

TECHNICAL SPECIFICATIONS

	Deluxe	Basic
Front plate	Aluminium	Plastic [ASA]
Front plate dimensions	180 x 180 mm	170 x 170 mm
Louvre base dimensions	150 x 150 mm	150 x 150 mm
Colour	RAL 9010	RAL 9010
Fixation	Magnets	Click system
Paintable	Yes	-
Acoustic material	Yes [pulse]	Yes [pulse]
Deflector plates	2 pieces [pulse]	-
Deflector plates dimensions	92 x 20 mm	-

EXTRACTION

Q [m³/h]	100% open		66% open		33% open	
	dP [Pa]	LwA [dB(A)]	dP [Pa]	LwA [dB(A)]	dP [Pa]	LwA [dB(A)]
30	2	15.0	3	14.8	14	17.9
50	6	16.9	10	20.0	40	30.2
60	8	20.3	15	24.6	56	34.7
75	13	25.5	23	31.4	82	40.5

PULSE WITHOUT ACOUSTIC MATERIAL

Q [m³/h]	100% open		66% open		33% open	
	dP [Pa]	LwA [dB(A)]	dP [Pa]	LwA [dB(A)]	dP [Pa]	LwA [dB(A)]
30	3	15.0	5	15.1	14	24.5
40	6	16.3	8	18.8	25	33.5
50	8	17.5	12	22.5	37	39.9
60	11	19.3	17	28.0	54	45.5
75	16	24.5	26	35.0	83	51.5

PULSE WITH ACOUSTIC MATERIAL

Q [m³/h]	100% open		66% open		33% open	
	dP [Pa]	LwA [dB(A)]	dP [Pa]	LwA [dB(A)]	dP [Pa]	LwA [dB(A)]
30	9	16.0	19	17.6	58	21.0
50	19	23.0	41	26.0	131	35.4
60	25	26.6	55	29.6	180	40.9
75	37	32.3	78	35.0	263	46.3

PURO - SQUARE - DIAGONAL

Design extraction louvres

HIT AND MISS
LOUVRE

DESIGN



Puro

TECHNICAL SPECIFICATIONS

Type	Dimensions [mm]	White
XD25-50 PURO	130 x 130, Ø 80	66031630
XD75 PURO	170 x 170, Ø 125	66031631



Square

TECHNICAL SPECIFICATIONS

Type	Dimensions [mm]	White
XD25-50 SQUARE	130 x 130, Ø 80	66031632
XD75 SQUARE	170 x 170, Ø 125	66031633

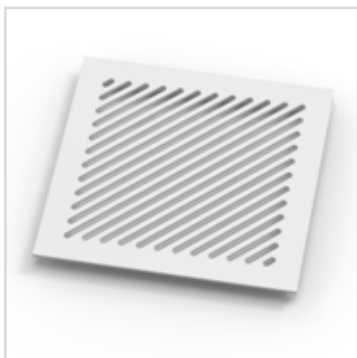

Diagonal

TECHNICAL SPECIFICATIONS

Type	Dimensions [mm]	White
XD25-50 DIAGONAL	130 x 130, Ø 80	66031634
XD75 DIAGONAL	170 x 170, Ø 125	66031635

AQUA - ARTIST - DECO

Design extraction louvres

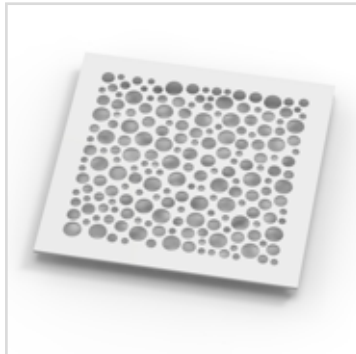

Aqua

TECHNICAL SPECIFICATIONS

Type	Dimensions (mm)	White
XD25-50 AQUA	130 x 130, Ø 80	66031636
XD75 AQUA	170 x 170, Ø 125	66031637

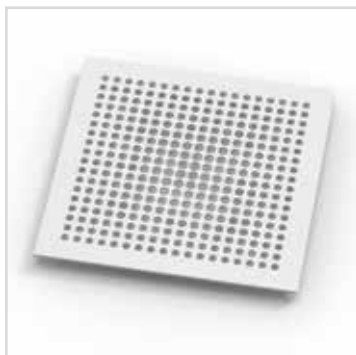

Artist

TECHNICAL SPECIFICATIONS

Type	Dimensions (mm)	White
XD25-50 ARTIST	130 x 130, Ø 80	66031638
XD75 ARTIST	170 x 170, Ø 125	66031639



Deco

TECHNICAL SPECIFICATIONS

Type	Dimensions (mm)	White
XD25-50 DECO	130 x 130, Ø 80	66031642
XD75 DECO	170 x 170, Ø 125	66031643

435R

Circular built-in punched grille

PUNCHED
GRILLE

ALUMINIUM

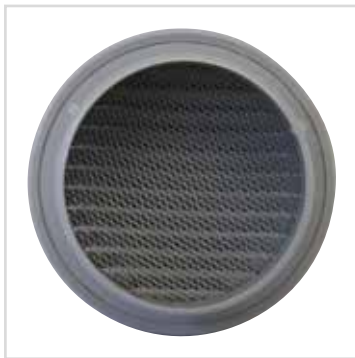

MATERIAL

- Made from punched aluminium sheet
- Finishing: powder-coated in white [RAL 9010], brown [RAL 8019] and aluminium [RAL 9006] colours
- Insect mesh included

STOCK MODELS

Diameter mm	RAL 9006	Renson Standard WHITE	RAL 8019	STR 7016	STR 9005	Airway opening in cm ²	Airflow at 2 Pa [m ³ /h]
ø 80	04352001	04352002	04352003	04350803	04352009	27	8.3
ø 100	04352004	04352005	04352006	04351003	04352169	51	15.2
ø 120	04351151	04351156	04351157	04351203	04351159	75	23.6
ø 150	04351451	04351456	04351457	04351503	04352179	119	35.2
ø 190	04351901	04351906	04351907	04351903	04351909	204	53.1
ø 250	04352451	04352456	04352457	04352453	04352459	339	74.0

Other colours are available upon request; only for large quantities.

TECHNICAL DRAWINGS

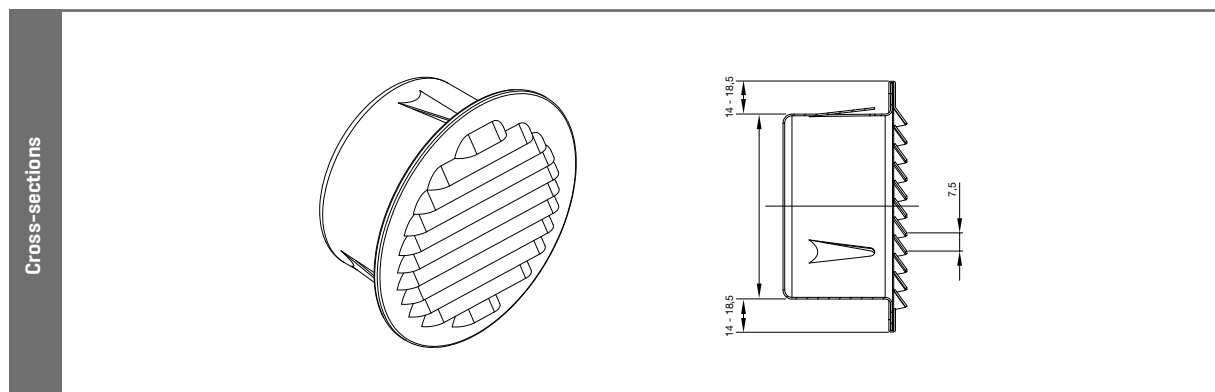



Punched grille 435R

436

Rectangular punched grilles

! CHANGED ARTICLE NUMBERS !

PUNCHED GRILLE

ALUMINIUM



436 - Punched grille

MATERIAL

- Punched aluminium sheet
- 436: without insect mesh
- 436-M: with insect mesh

Remark: standard dimensions only, not possible made-to-measure.

FIXING

- Screw-mounted [screws and plugs not provided]

TECHNICAL SPECIFICATIONS

- Physical free area: 28%

STOCK MODELS

(W x H) mm	F1	Renson Standard WHITE	RAL 8019	STR 7016	STR 9005	Airflow at 2 Pa [m³/h]
150 x 150	51501501	51501506	51501507	51501503	51501509	16
150 x 200	51502001	51502006	51502007			21,9
200 x 100	52001001	52001006	52001007	52001003	52001009	12
200 x 200	52002001	52002006	52002007	52002003	52002009	22,1
200 x 250	52002501	52002506	52002507	52002503	52002509	36,7
250 x 100	52501001	52501006	52501007			18,5
250 x 250	52502501	52502506	52502507			46,6
300 x 100	53001001	53001006	53001007			20,2
300 x 300	53003001	53003006	53003007	53003003	53003009	73,5
400 x 100	54001001	54001006	54001007			28,8
400 x 400	54004001	54004006	54004007			86,4
500 x 500	55005001	55005006	55005007			125,9

TECHNICAL DRAWINGS

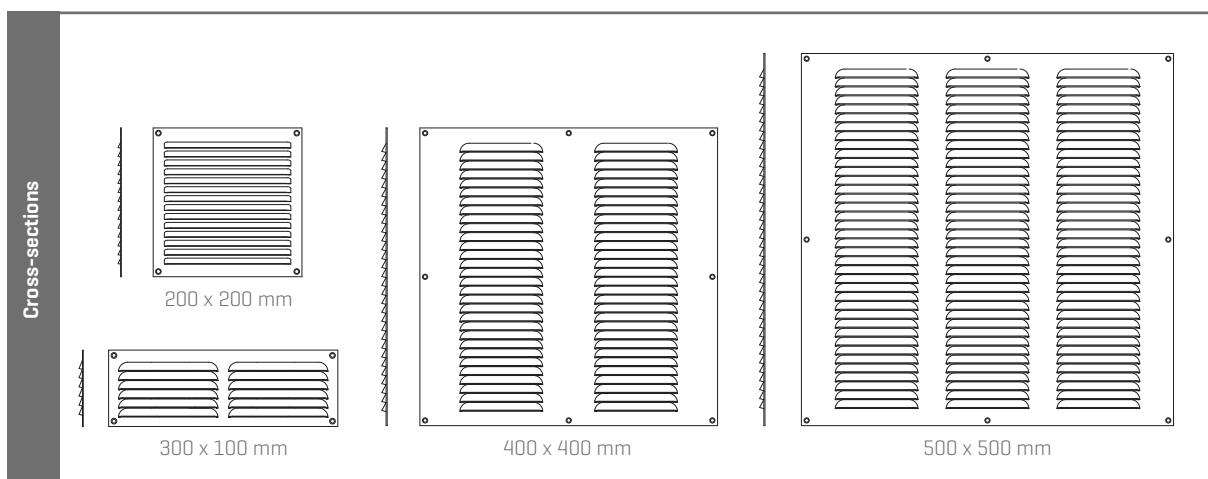

437

Rectangular punched grilles

437 - Punched grille with frame

MATERIAL

- Punched aluminium sheet with frame
- With insect mesh

Remark: standard dimensions only, not possible made-to-measure.

FIXING

- Screw-mounted [screws and plugs not provided]

STOCK MODELS

[W x H] mm	F1	Renson Standard WHITE	RAL 8019	STR 7016	STR 9005	Airflow at 2 Pa [m ³ /h]
150 x 150	61501501	61501506	61501507	61501503	61501500	16
150 x 200	61502001	61502006	61502007			21.9
200 x 100	62001001	62001006	62001007			12
200 x 200	62002001	62002006	62002007	62002003	62002000	22.1
200 x 250	62002501	62002506	62002507			36.7
250 x 100	62501001	62501006	62501007			18.5
250 x 250	62502501	62502506	62502507			46.6
300 x 100	63001001	63001006	63001007			20.2
300 x 300	63003001	63003006	63003007			73.5
400 x 100	64001001	64001006	64001007			28.8
400 x 400	64004001	64004006	64004007			86.4
500 x 500	65005001	65005006	65005007			125.9



TECHNICAL DRAWINGS

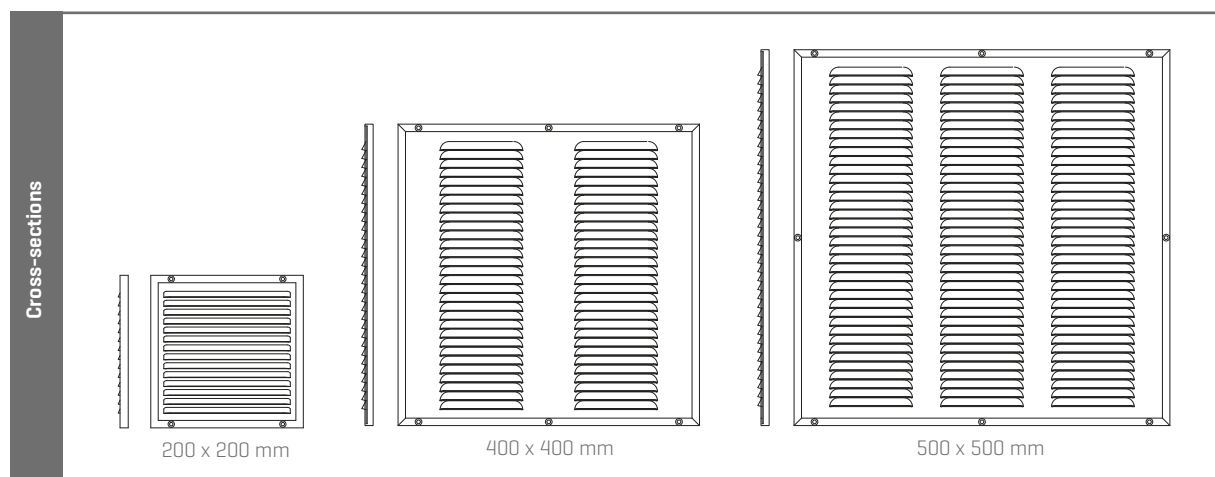

438 - 439

Rectangular punched grilles

PUNCHED
GRILLE

STAINLESS
STEEL



438 - Punched grille, stainless steel

MATERIAL

- Punched stainless steel sheet

Remark: standard dimensions only, not possible made-to-measure.

FIXING

- Screw-mounted [screws and plugs are not provided]

STOCK MODELS

(W x H) mm	Stainless steel	Airflow at 2 Pa (m ³ /h)
150 x 150	91501501	15,8
200 x 200	92002001	21,3
250 x 100	92501001	16,2

Available until end of stock:

(W x H) mm	Stainless steel	Airflow at 2 Pa (m ³ /h)
200 x 250	82002501	29,7

439 - Punched grille, edge-raised

MATERIAL

- Punched aluminium sheet

Remark: standard dimensions only, not possible made-to-measure.

FIXING

- Screw-mounted [screws and plugs are not provided]



STOCK MODELS

[W x H] mm	F1	Renson Standard WHITE	RAL 8019	Airflow at 2 Pa (m ³ /h)
155 x 155	21551551	21551556	21551557	15.9
245 x 195	22451951	22451956	22451957	31.4
215 x 150	22151501	22151506	22151507	20.3

381

Built-in ventilation grille

VENTILATION
STRIP

ALUMINIUM

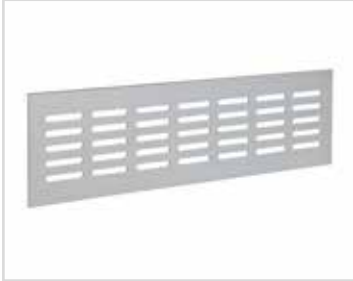

MATERIAL

- Made from aluminium sections: AlMgSi 0.5 [according to EN 12020-2]

TYPICAL APPLICATIONS

- Kitchens, refrigerators, counters
- Packaging quantity: 10 pieces*





STOCK MODELS

Dimensions (W x H) mm	Natural-coloured anodised	Renson Standard WHITE	RAL 8022	STR 9005	Air flow opening at cm ²	Airflow at 2 Pa (m ³ /h)
400 x 60 mm	03810041	03810046	03810047		44	17.0
500 x 60 mm	03810051	03810056	03810057		59	22.8
2000 x 60 mm	03810201	03810206			244	94.4
300 x 80 mm	03811031	03811036	03811037		43	17.6
400 x 80 mm	03811041	03811046	03811047	03811042	56	22.4
500 x 80 mm	03811051	03811056	03811057	03811059	74	29.6
600 x 80 mm	03811061	03811066			87	33.6
1000 x 80 mm	03811101	03811106			149	57.6
2000 x 80 mm	03811201				305	117.9
300 x 100 mm	03812031	03812036			61	23.6
400 x 100 mm	03812041	03812046	03812047		78	30.2
500 x 100 mm	03812051	03812056	03812057		104	40.2
600 x 100 mm	03812061	03812066	03812067		122	47.2
1000 x 100 mm	03812101	03812106			209	80.8
2000 x 100 mm	03812201	03812206			427	165.1
500 x 130 mm	03813051	03813056			149	57.6
1000 x 130 mm	03813101	03813106			298	115.2
2000 x 130 mm	03813201	03813206			610	235.9
500 x 150 mm	03815051	03815056			179	69.2
2000 x 150 mm	03815201	03815206			732	283.1

Other colours are available upon request; only for large quantities.

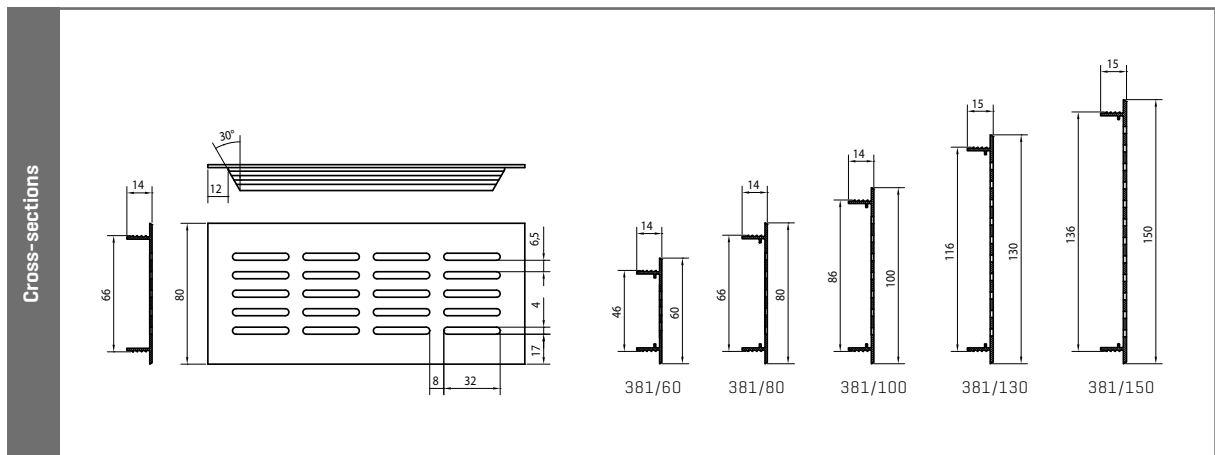
TECHNICAL DRAWINGS





Get inspired in our showroom
EXIT5 at Waregem along the E17

EXIT5

EXPERIENCE, INNOVATION & TECHNOLOGY @ RENSON

WE'D BE HAPPY TO HELP YOU!

Our head office - the elegant building designed by the late architect Jo Crepain, which has been the visiting card of our company for many years now - is now being renovated. The bottom part of the building now has an imposing glass façade. Behind the façade, there is a new 'Customer Centre' with reception rooms for customers, conference rooms, and an auditorium, where large groups of more than 300 people can participate in presentations. In case of smaller groups, this auditorium can also be divided into 3 separate rooms.

The highlight of the project is the new showroom of 1250 m², where professional customers as well as private individuals can be accommodated. Apart from a showroom for Renson®'s various innovative solutions and concepts, it is planned to make this room a knowledge centre, where customers can walk in and ask questions about ventilation, heating, sun protection, ventilative cooling, acoustics, interior, etc., In short: everything to provide the home with all the necessary comfort. There is also the possibility to view the solutions in practice in show houses located nearby.

For more information about the network of Renson® ambassadors, please visit our website at: www.renson.eu

RENSON®: YOUR PARTNER IN VENTILATION, SUN PROTECTION, AND OUTDOOR CONCEPTS

- **Creating healthy spaces**

With experience dating back to 1909, we develop energy-efficient total solutions that provide healthy and table indoor environments. Our remarkable head office, built according to the Healthy Building Concept, perfectly reflects our corporate mission.

- **No speed limit on innovation**

A multidisciplinary team of more than 90 R&D employees continuously optimises our products and develops innovative total concepts.

- **Strong in communication**

Contact with the customer is of the utmost importance. Our own exterior sales team, with more than 100 members of staff worldwide and a strong international distribution network, is available to advise you on-site. EXIT 5 in Waregem also gives you the opportunity of personally experiencing our products and provides continuous training to our installers.

- **A reliable partner in business**

Thanks to our environmentally friendly and modern production facilities [including automatic powder-coating installation, anodisation unit, PVC injection moulding, mould-making], with a total surface area of 95,000 m², we can always guarantee optimal quality and service to our customers.





RENSON® Headquarters
Maalbeekstraat 10, IZ 2 Vijverdam, B-8790 Waregem, Belgium
Tel. +32 56 30 30 00
info@renson.eu
www.renson.eu

