

MECHANICAL VENTILATION



OUR MISSION

Creating healthy spaces



Paul Renson

Renson® specialises in ventilation, sun protection and terrace coverings. With experience dating back to 1909 and a team of more than 1000 employees, we develop solutions with which we strive for a healthy and comfortable living and working environment for the consumer. In doing so, we take the requirements into account regarding energy efficiency and the use of renewable energy, as well as ease of maintenance. We offer total solutions that can turn every home into a healthy and comfortable environment. This leads us to our baseline "Creating Healthy Spaces".

"Additionally, we also consider the aesthetic value of each building. This way, our ventilation and sun protection systems can be integrated almost invisibly. The terrace coverings and aluminium blinds for the wall cladding set clear visible accents, which give added value to the architecture. On the inside, we ensure invisible integration of the doors without distracting frames or visible hinges."

"We not only develop innovative solutions, but also think about the aesthetic added value of each building."

Discover how Renson® products can optimize the comfort experience within a contemporary design.

CONTENTS

RANGE OVERVIEW	p. 4	ACCESSORIES	
INTRODUCTION		Easyflex®	p. 63
Why ventilate?	p. 7	*Kits Healthbox® 3.0	p. 66
Ventilation systems	p. 9	*Kits ø125 & ø80 Endura® E*	p. 67
VENTILATION SYSTEMS		Controls	p. 69
System C		Sensors	p. 70
Cbase	p. 11	*Accessories Xtravent EcoModus Compact	p. 71
System C*		*Accessories Endura®	p. 72
*Cube®	p. 15	Design extraction louvres	p. 75
*Xtravent EcoModus Compact	p. 19	Accessories design extraction louvres	p. 77
Demand-controlled ventilation	p. 22	SQair valve	p. 79
System C*		Connection accessories	p. 80
*Healthbox® 3.0 [Smart - 0,90]	p. 26	Roof exhausts	p. 82
Smart ventilation due to SmartZone	p. 28	Easyduct	p. 84
*Healthbox® 3.0 [SmartZone - 0,61]	p. 30	CO ₂ monitor	p. 85
*Healthbox® 3.0 [SmartZone - 0,50]	p. 32	TECHNICAL DATA SHEETS	
*Healthbox® 3.0 [SmartZone - 0,43]	p. 34	Cbase	p. 88
Renewable energy	p. 37	*Cube®	p. 89
System E*	p. 39	*Xtravent EcoModus Compact	p. 90
Endura® E [Smart - 0,90]	p. 40	*Healthbox® 3.0	p. 92
Endura® E [SmartZone - 0,61]	p. 42	Endura® Delta 330	p. 100
Endura® E [SmartZone - 0,50]	p. 44	Endura® Delta 380	p. 104
Endura® E [SmartZone - 0,43]	p. 46	Endura® Delta 450	p. 108
System D*	p. 49	Comparison Endura® Delta 330-380-450	p. 112
*Endura® Delta [Smart - 0,93]	p. 50	*Endura®	p. 114
*Endura® Delta [Sense - 0,87]	p. 52	Healthconnector®	p. 118
*Endura® Delta [Sense - 0,70]	p. 54	Design extraction louvres	p. 126
*Endura® Delta [Sense - 0,61]	p. 56	SQair valve	p. 128
Healthconnector®	p. 59	Flexible ducts	p. 130
		Easyduct	p. 137
		Easyflex®	p. 150
		Design roof exhaust	p. 179
		Wall louvres	p. 187
		CO ₂ monitor	p. 190

[*] These configurations are only valid for the territory of Belgium.

RANGE OVERVIEW

		System C	System C*					
Box		Cbase	Cube®	Xtravent Ecomodus Compact	Healthbox® 3.0			
Configuration		-	-	-	Smart -0,90	SmartZone -0,61	SmartZone -0,50	SmartZone -0,43
Reduction factors BA ≤ 2015	Heat	1,00	0,74	0,94	1,00*	1,00*	1,00*	1,00*
	Cool	1,00	0,74	0,94	1,00*	1,00*	1,00*	1,00*
	Overheat	1,00	0,74	0,94	1,00*	1,00*	1,00*	1,00*
Reduction factors BA ≥ 2015	Heat	1,00	1,00	0,90	0,90	0,61	0,50	0,43
	Cool	1,00	1,00	0,90	1,00	1,00	1,00	1,00
	Overheat	1,00	1,00	0,90	1,00	1,00	1,00	1,00
Page		11, 88	15, 89	19, 90	26, 92	30, 92	32, 92	34, 92
Control	Kitchen	-	CO ₂ RH central	RH presence	CO ₂			
	Bathroom [with or without toilet]	-	RH central presence	RH presence	RH VOC			
	Toilet	-	RH central presence	RH presence	VOC			
	Other wet rooms	-	RH central	RH central	RH			
	Living room [open kitchen]	-	-	-	-			
	Living room [closed kitchen]	-	-	-	-			
	Main bedroom	-	-	-	-	CO ₂ central	CO ₂	
	Other bedrooms	-	-	-	-	CO ₂ central	CO ₂	
	Other dry rooms	-	-	-	-			
	Proposed natural supply	Self-regulating vents Renson P3/P4	Self-regulating vents Renson P3/P4	Self-regulating vents Renson P3/P4	Self-regulating vents Renson P3/P4			
Lining-up	Manually	Manually	Manually	Self-regulating				

*Healthbox 3.0 has no ATG-E for building applications before 2015. Healthbox II must be used for this.

		System E ⁺				System D ⁺			
Extraction		Endura [®]				Endura [®] Delta			
Configuration		Smart -0,90	SmartZone -0,61	SmartZone -0,50	SmartZone -0,43	Smart -0,93	Sense -0,87	Sense -0,70	Sense -0,61
Reduction factors BA ≤ 2015	Heat	0,65	0,45	0,40	0,40	1,00	1,00	1,00	1,00
	Cool	0,65	0,45	0,40	0,40	1,00	1,00	1,00	1,00
	Overheat	0,65	0,45	0,40	0,40	1,00	1,00	1,00	1,00
Reduction factors BA ≥ 2015	Heat	0,90	0,61	0,50	0,43	0,93	0,87	0,70	0,61
	Cool	1,00	1,00	1,00	1,00	1,00	1,00	1,00	1,00
	Overheat	1,00	1,00	1,00	1,00	1,00	1,00	1,00	1,00
Page		40, 114	42, 114	44, 114	46, 114	50, 100	52, 100	54, 100	56, 100
Control	Kitchen	CO ₂				VOC central Central RH CO ₂ central			
	Bathroom [with or without toilet]	RH VOC							
	Toilet	VOC							
	Other wet rooms	RH							
	Living room [open kitchen]	-				-	CO ₂	-	CO ₂
	Living room [closed kitchen]	-			CO ₂	-	CO ₂	-	CO ₂
	Main bedroom	-	CO ₂ central	CO ₂		-	CO ₂		
	Other bedrooms	-	CO ₂ central	CO ₂		-		CO ₂	
	Other dry rooms	-			CO ₂	-			CO ₂
	Proposed natural supply	Self-regulating vents Renson P3/P4				-			
Lining-up	Self-regulating				Manually				



WHY VENTILATE?

Contrary to what many people think, the inside air quality is on average 10 times worse than the outdoor air quality. Cooking, showering, heating, cleaning and even breathing and sweating ensure polluted air. Too much moisture inside also leads to odours, condensation and mould, especially in well insulated or insufficiently ventilated houses. And then there is the house itself, that, with volatile organic compounds [such as formaldehyde] in the building materials used, also has a bad effect on indoor air quality.

GOOD FOR THE OCCUPANT AND THE HOME

Many people are convinced that occasionally opening the windows is enough to provide the necessary ventilation. However, the effect achieved is temporary and local. Moreover, ventilation through open windows is not controlled, resulting in costly energy loss. Open windows are also accompanied by noise nuisance and are an invitation to burglars and annoying insects.

Continuous and controlled ventilation is your only guarantee of a healthy indoor climate. The polluted inside air is discharged and continuously replaced by fresh outside air. The house will, as a result, be 'rinsed' with fresh air.

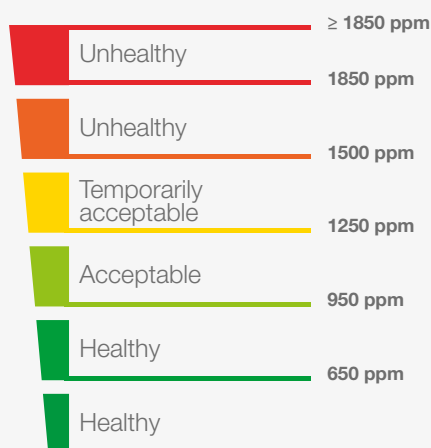

In the long run, a poor indoor climate can damage the residents' health. Respiratory problems, dry throat, eye irritation, headache, allergies, concentration loss, energy shortage or drowsiness are just some of the possible consequences. That is why it is extremely important to maintain thorough ventilation on a regular basis.

CO₂ MONITOR

The CO₂ concentration is an important indicator for good indoor air quality and can be measured with the Renson® CO₂-monitor. The air quality becomes expressed in CO₂ particles per million air particles. [ppm = parts per million].

The maximum assumed value is 1200 ppm CO₂. Above this value, people may suffer headache, drowsiness, fatigue or irritation of the mucous membranes at a CO₂ concentrations above 1000 ppm the concentration ability decreases.





VENTILATION SYSTEMS

Continuous and controlled ventilation is a must, especially in increasingly well insulated and airtight finished houses, offices and schools. Whether for a renovation or new buildings, the predetermined energy requirements, whether user-friendly and maintenance-friendly it should be and how fresh air is supplied, there is a suitable ventilation system for each project that meets the personal needs of the residents or users.

THE DIFFERENT VENTILATION SYSTEMS

The ventilation standards NBN D50-001 and NEN 1087/8088 define 4 systems: A, B, C and D

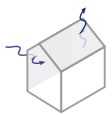

System A: Natural supply,
natural extraction



System B: Mechanical supply,
natural extraction



System C: Natural supply,
mechanical extraction



System D: Mechanical supply,
mechanical extraction

Next to these systems, Renson® offers demand-controlled ventilation under the names: **System C+®, System D+® and System E+®.**



System C+®: Natural supply,
demand-controlled extraction
per room



System D+®:
Demand-controlled supply &
extraction with heat recovery



System E+®:
Natural supply, demand-
controlled mechanical
extraction with heat recovery
for domestic hot water and
heating.



SYSTEM C

Cbase: not demand-controlled, central extraction of polluted air

The Renson® C system uses a combination of self-regulating Invisivent window ventilations and a discharge fan to create a pleasant and healthy indoor climate.



- Fresh outdoor air supply
- Drainage of polluted indoor air
- Fresh outdoor air for nightcooling
- Outdoor sun protection



Cbase

Central extraction of polluted air from the home.

Technical data sheet page 87

SYSTEM C

Cbase: not demand-controlled, central extraction of polluted air

1,0

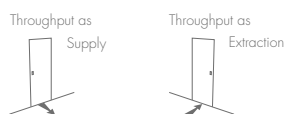
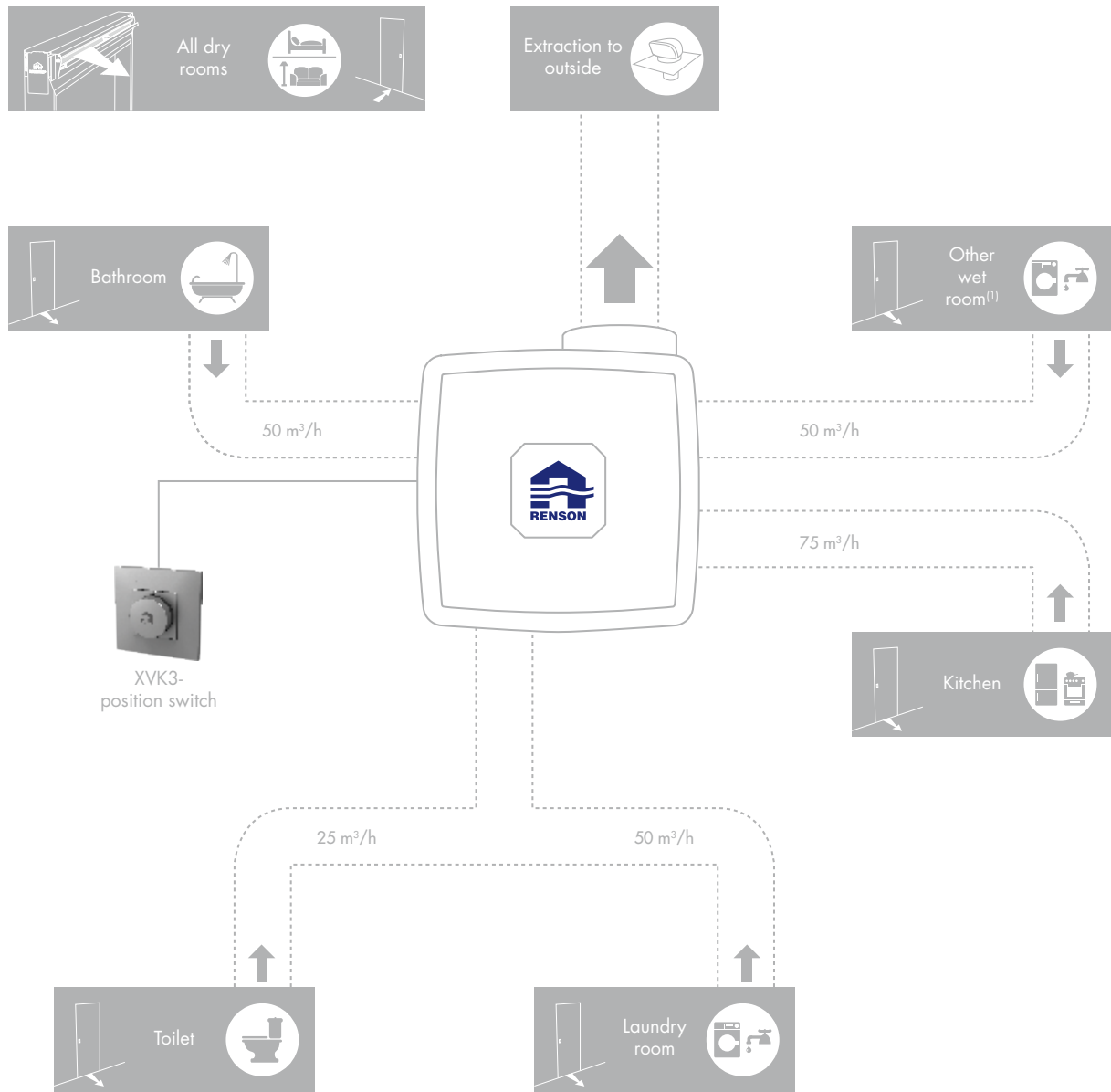

Shading factors	
$f_{\text{reduc,vent,heat}}$	= 1,00
$f_{\text{reduc,vent,cool}}$	= 1,00
$f_{\text{reduc,vent,overheat}}$	= 1,00

The air flows displayed are only indicative. Minimum air flow to be determined in accordance with EPB decision.
⁽¹⁾ Laundry room, drying room or analogue room

Basis package Cbase

Kit

- 1 x motor unit EX330CB
- 4 x cover cap and/or Red Ø125 > Ø80
- 2 x cover cap Ø125
- 1 x adaptor 125-150 mm (exhaust)
- 1 x power cord

66034200



Also see page 87

Modular grill frame

- Ø80**
- Ø125**

- 1 x grill frame
- 1 x plaster cardboard

66031624
66031625

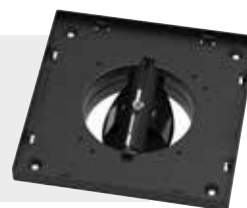

Also see page 61

Position switch

XVK3 position switch

66014049



Also see page 61

Cover plate

Cover plate Puro Ø80
Cover plate Puro Ø125

66031630
66031631

Cover plate Square Ø80
Cover plate Square Ø125

66031632
66031633

Cover plate Diagonal Ø80
Cover plate Diagonal Ø125

66031634
66031635

Cover plate Aqua Ø80
Cover plate Aqua Ø125

66031636
66031637

Cover plate Artist Ø80
Cover plate Artist Ø125

66031638
66031639

Cover plate Deco Ø80
Cover plate Deco Ø125

66031642
66031643

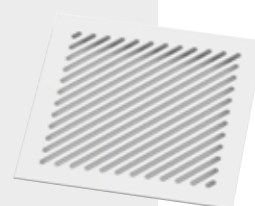

Also see page 61

Design valves

SQair extraction valve [Deluxe]
SQair extraction valve [Basic]

76050401
76050404



Also see page 61



SYSTEM C+®

Cube®: Demand-controlled, central extraction of polluted air

Renson® C+ systems use a combination of self-regulating Invisivent window ventilations and demand-controlled discharge ventilation [using **room sensors**] to create a pleasant and healthy indoor climate.



- Fresh outdoor air supply
- Drainage of polluted indoor air
- Fresh outdoor air for nightcooling
- Outdoor sun protection



Cube®

Demand-controlled, **central** extraction of polluted air from the home.

Technical data sheet page 87

SYSTEM C+®

Cube®: Demand-controlled, central extraction of polluted air

1,0

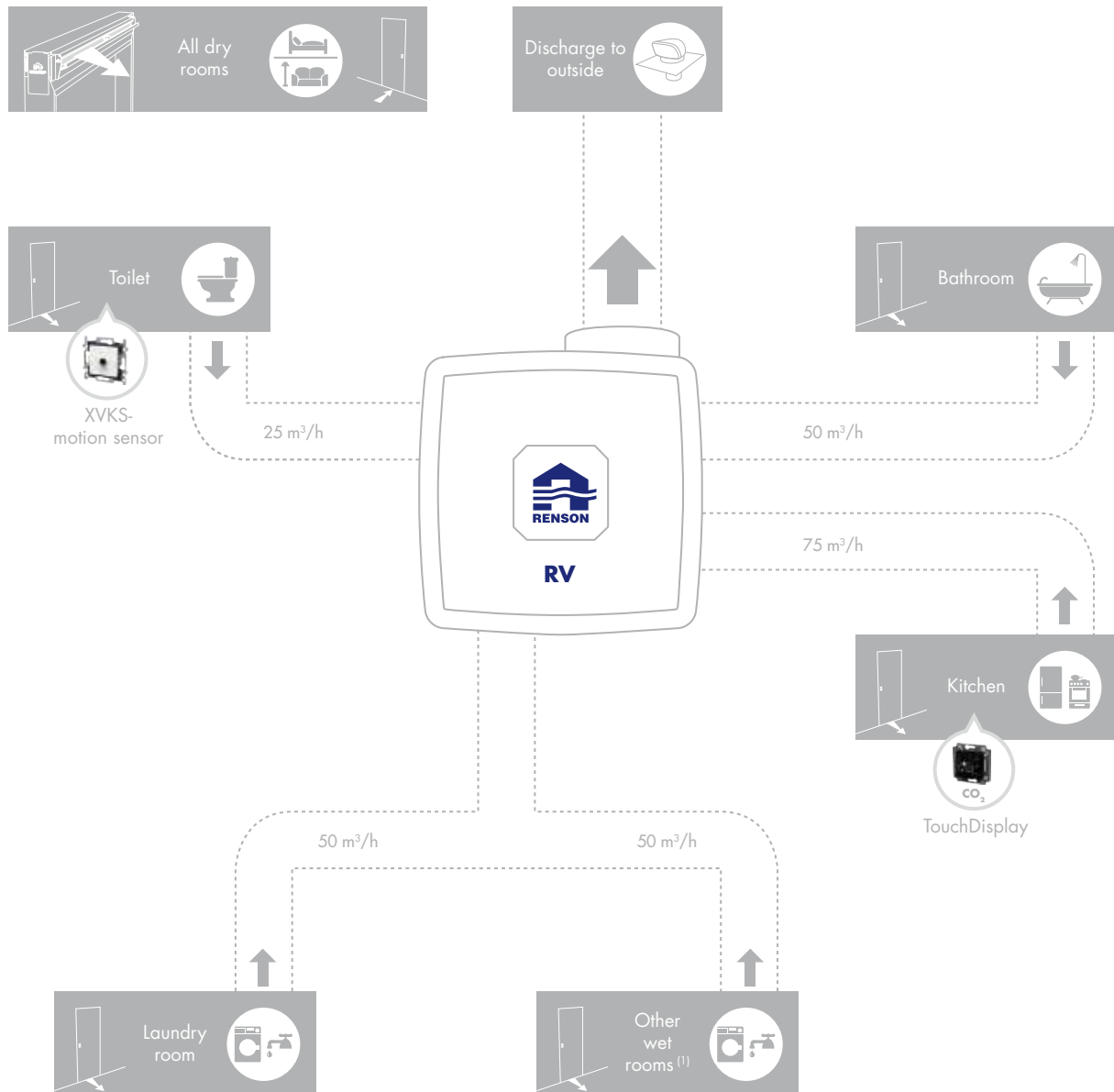

Shading factors	
$f_{\text{reduc,vent,heat}}$	= 1,00
$f_{\text{reduc,vent,cool}}$	= 1,00
$f_{\text{reduc,vent,overheat}}$	= 1,00

RV = Relative humidity detection (central in the unit) CO₂ = Carbon dioxide detection
 The air flows displayed are only indicative. Minimum air flow to be determined in accordance with EPB decision.
 ¹) Laundry room, drying room or analogue room

Building application from 2015 onwards

Basic package Cube®

Kit

66034300

1 x motor unit EX425CU
1 x XVKS motion sensor
1 x TouchDisplay with CO₂ sensor

Also see page 87



Modular grill frame

Ø80
Ø125

66031624
66031625

1 x grill frame
1 x plaster cardboard

Also see page 61

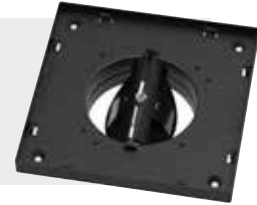

TouchDisplay

With integrated CO₂ sensor
Sensorless control

66032202
66032203

Also see page 61



Motion sensor

XVKS

66031720

1 x XVKS-sensor white
Compatible with Cube
Cover plate not included

Also see page 61



Cover plate

Cover plate Puro Ø80
Cover plate Puro Ø125

66031630
66031631

Cover plate Square Ø80
Cover plate Square Ø125

66031632
66031633

Cover plate Diagonal Ø80
Cover plate Diagonal Ø125

66031634
66031635

Cover plate Aqua Ø80
Cover plate Aqua Ø125

66031636
66031637

Cover plate Artist Ø80
Cover plate Artist Ø125

66031638
66031639

Cover plate Deco Ø80
Cover plate Deco Ø125

66031642
66031643

Also see page 61

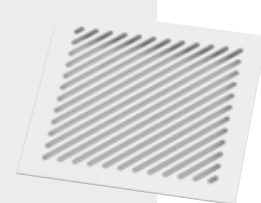

Design valves

SQair extraction valve [Deluxe]
SQair extraction valve [Basic]

76050401
76050404

Also see page 61





SYSTEM C+®

Xtravent: demand & zone controlled extraction of polluted air

The Renson® C+ systems use a combination of self-regulating Invisivent window ventilations and demand-controlled discharge ventilation (using **room sensors**) to create a pleasant and healthy indoor climate.



- Fresh outdoor air supply
- Drainage of polluted indoor air
- Fresh outdoor air for nightcooling
- Outdoor sun protection



Xtravent Ecomodus Compact

Demand-controlled **local** extraction of polluted air from the home.

Technical data sheet page 87

SYSTEM C+®

Xtravent: demand & zone controlled extraction of polluted air

0,9

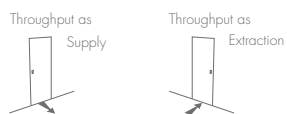
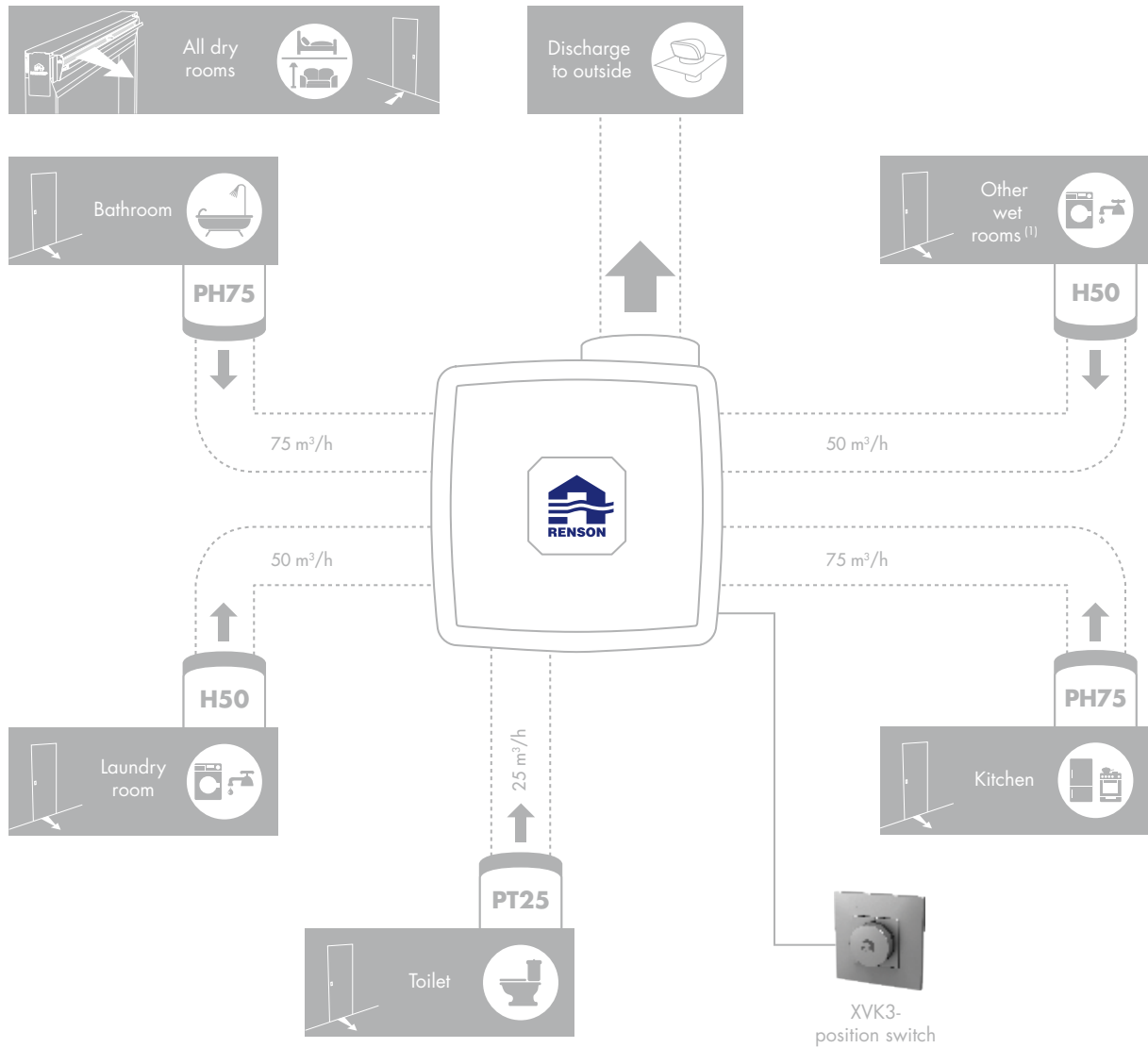

PH75: humidity + presence H50: humidity measurement PT25: presence

The air flows displayed are only indicative. Minimum air flow to be determined in accordance with EPB decision
 (1) Laundry room, drying room or analogue room

Shading factors	
$f_{\text{reduc,vent,heat}}$	= 0,90
$f_{\text{reduc,vent,cool (3)}}$	= 0,90
$f_{\text{reduc,vent,overheat (3)}}$	= 0,90

Building application from 2015 onwards

Basic package Xtravent Ecomodus Compact

Kit

66032000

- 1 x motor unit EX325MC
- 2 x extraction PH75 humidity + presence detection
- 1 x extraction PT25 presence detection + timer
- 1 x 3-position switch

Also see page 87



Extraction grill

PH75 Kitchen/Bathroom

66014030

H50 Laundry room

66014050

PT25 Toilet

66014040

- 1 x extraction grill
- 1 x serrated mounting flange
- Humidity measurement + presence detection [PH75] /
- humidity measurement [H50] / presence detection [PT25]

Also see page 61



Control switch

XVK3 position switch

66014049

Also see page 61



DEMAND CONTROLLED VENTILATION CENTRAL VS ZONE CONTROL

Each type C ventilation system in a home consists of at least a ventilation unit with an integrated fan. However, Renson® will keep innovating to raise this type of ventilation to a higher level to an intelligent, demand-controlled system, where the ventilation system adapts the discharge rate according to the needs and living pattern of the residents and the measured air quality.

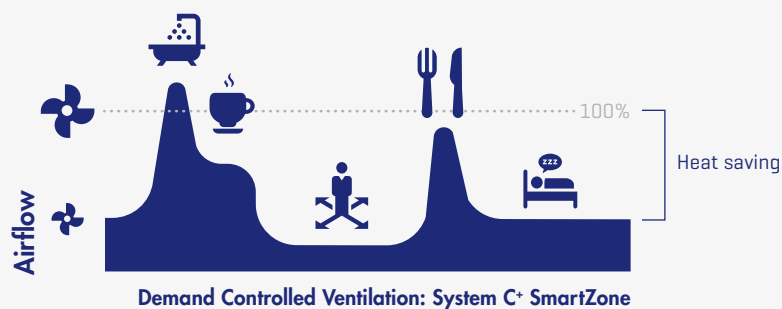

ZONE CONTROL: VENTILATE WHERE YOU LIVE

In this type of demand-control, the air flow is adjusted locally per room, according to the measured air quality [CO₂, H₂O and/or odour (VOC)]. The ventilation system will, if the air quality allows it, minimise ventilation and only extract more when necessary and then only in the specific rooms where pollution occurs. This type of ventilation gives you additional advantages over a ventilation system with **central control**:

1] Adjusting the ventilation intensity is completely automatic and only in the room where the pollution occurs.

a. Additional acoustic comfort:

The ventilation level is only adjusted in the room where pollution occurs. Unlike a centrally controlled system, there is no additional noise nuisance in one room when ventilation is activated in another.

b. Additional limitation of heating leak:

More than a centrally controlled ventilation system, a zone-controlled system will reduce heating leaks to a minimum. The total air flow from the home is therefore even lower than with a centrally controlled system.

c. Additional limitation of electrical consumption:

In analogy to the heating leak, electrical consumption of a zone-controlled system will also be lower, as the fan can run on a lower regime.

2] There are no sensors visible in the room. All sensors are integrated in the control valves of the ventilation system and no additional sensors need to be installed in the room.

Each control module is equipped with specific sensors for each type of room:



Symbol	Advice for the room to connect	Detection possibilities
	Laundry room <i>Shower room, bathroom (without toilet)</i>	H ₂ O
	Bathroom (with toilet) <i>Wellness, garage, cellar</i>	H ₂ O, VOC
	Toilet <i>Storage/technical area, workshop, dressing, hall/ corridor</i>	VOC
	Kitchen (open/closed)	CO ₂
	Bedroom <i>Living room, office, practice area, workspace, study, hobby room, waiting room/sitting area, baby room, children's room, TV/music room, relax room, dining room, playroom, attic</i>	CO ₂

Each control module is also equipped with temperature sensing.

SMARTCONNECT AND APP CONTROL

SmartConnect turns Healthbox 3.0 into a smart device that can communicate with the user/installer and other smart devices. This makes Healthbox 3.0 completely ready to be integrated into a smart home, resulting in greater overall comfort.

The accompanying app gives the user a clear insight of the air quality (H₂O, VOC and/or CO₂) and the ventilation level within the home. Due to various possible profiles, the user can personalise the ventilation level per room and can adjust ventilation even better to his needs.

The installer app on the other hand, ensures a clear step-by-step plan and thus, saves a lot of time during installation. The 'self learning'-factor helps installers forward on their way to high quality installations. Furthermore, all required information for the EPB declaration is digitally supplied via the app.

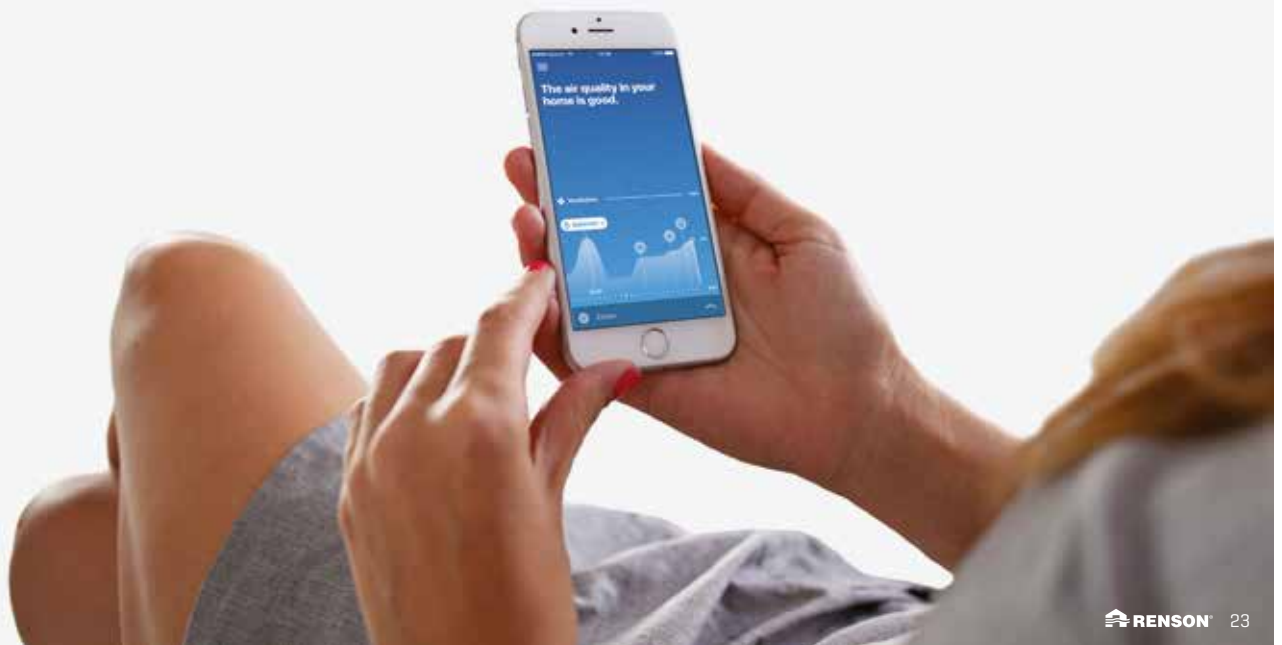

Orange

10:25

Configure



Healthbox 3.0 -- Control valves
Warranty n°: GKUIH159703K105

Country: Belgium

Zones | **Flow rate**

No.	Valve type	Qnom [m³/h]
1	Kitchen	75
21	Laundry Room	50
22	Bathroom	50
3	Bedroom	30

Disconnect

Calibrate

SYSTEM C+®

Healthbox® 3.0: demand & zone controlled extraction of polluted air

The Renson® C+ systems use a combination of self-regulating Invisivent window ventilations and demand-controlled discharge ventilation [**controlled per zone**] to create a pleasant and healthy indoor climate.



- Fresh outdoor air supply
- Drainage of polluted indoor air
- Fresh outdoor air for nightcooling
- Outdoor sun protection



Healthbox® 3.0

Demand-controlled **zone controlled** extraction of polluted air from the home.

Technical data sheet page 87

Healthbox 3.0 is equipped to ventilate up to 7 rooms as standard. By using valve collectors, it is possible to ventilate up to 11 rooms.

SYSTEM C+®

Healthbox® 3.0: demand & zone controlled extraction of polluted air

0,9

Smart - 0,90

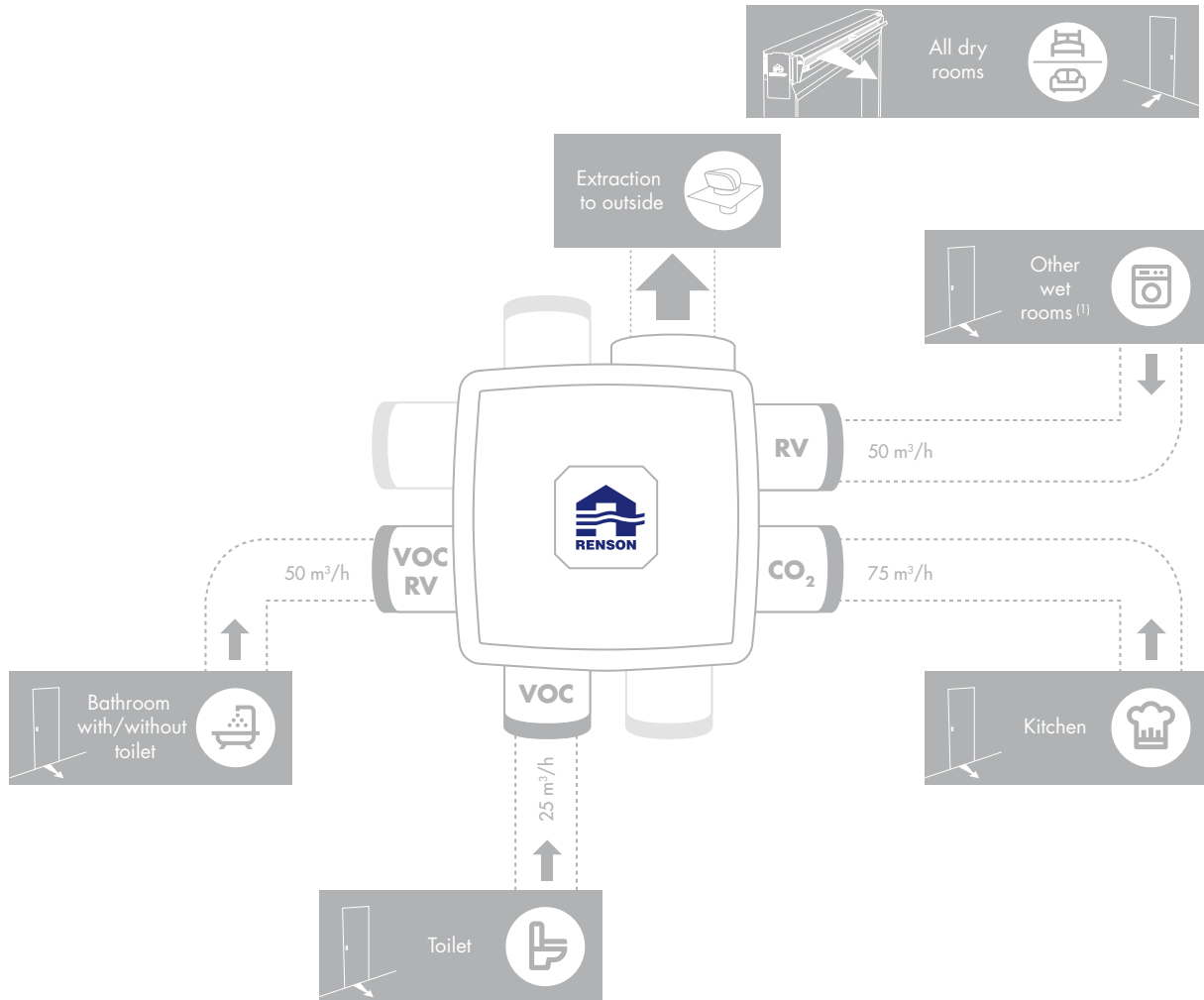

Each valve controls a maximum of 1 local.
 RV = Relative humidity detection VOC = Volatile organic components detection CO₂ = Carbon dioxide detection
 The position of the valves can be freely determined.
 Breeze function present = demand controlled automatic deactivation in case of overheating
 The air flows displayed are only indicative. Minimum air flow to be determined in accordance with EPB decision.
 (1) laundry room, drying room or analogue room

Shading factors	
$f_{\text{reduc,vent,heat}}$	= 0,90
$f_{\text{reduc,vent,cool (3)}}$	= 1,00
$f_{\text{reduc,vent,overheat (3)}}$	= 1,00

Building application from 2015 onwards

Basic package Healthbox® 3.0

Kit Healthbox 3.0

1 x Healthbox 3.0 motor unit
1 x kitchen kit
1 x bathroom kit with toilet
1 x toilet kit

66060100



Also see page 87

Kit

Kitchen kit CO₂
Bathroom kit VOC + H₂O
Toilet kit VOC
Laundry room kit H₂O

66060123

66060121

66060122

66060120



Also see page 61

Kit valve collector

T-piece

1 x T-piece
2 x adaptor 125-80

66060118

Print

1 x print
2 x self tapping screw
1 x patch cable 0.5 m

66060119



Also see page 61

Cover plate

Cover plate Puro Ø80
Cover plate Puro Ø125

66031630

66031631

Cover plate Square Ø80
Cover plate Square Ø125

66031632

66031633

Cover plate Diagonal Ø80
Cover plate Diagonal Ø125

66031634

66031635

Cover plate Aqua Ø80
Cover plate Aqua Ø125

66031636

66031637

Cover plate Artist Ø80
Cover plate Artist Ø125

66031638

66031639

Cover plate Deco Ø80
Cover plate Deco Ø125

66031642

66031643

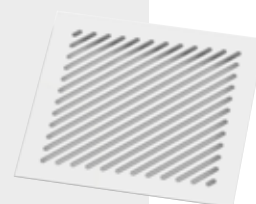

Also see page 61

Design valves

SQair extraction valve [Deluxe]
SQair extraction valve [Basic]

76050401

76050404



Also see page 61

SMART VENTILATION THANKS TO SMARTZONE

With the unique Smart Zone principle, polluted indoor air is removed not only in the humid areas, but also in the bedrooms. With different values, the ventilation pattern is adjusted even more to the practical needs of the residents.

Intelligent sensors, integrated into the ventilation unit's control valves, continuously measure the air quality in each room of the home and adjust ventilation air flow if necessary. For example, if the residents watch television in the evening, the ventilation system ensures an increased extraction in the living area. If they go to sleep, the control valve of the ventilation system detects

an increase of the CO₂ level in the bedroom and more polluted air is extracted there. Natural supply and mechanical extraction are therefore adapted to each other in order to achieve good air quality in every room and thus, ensure a good, healthy night's sleep.



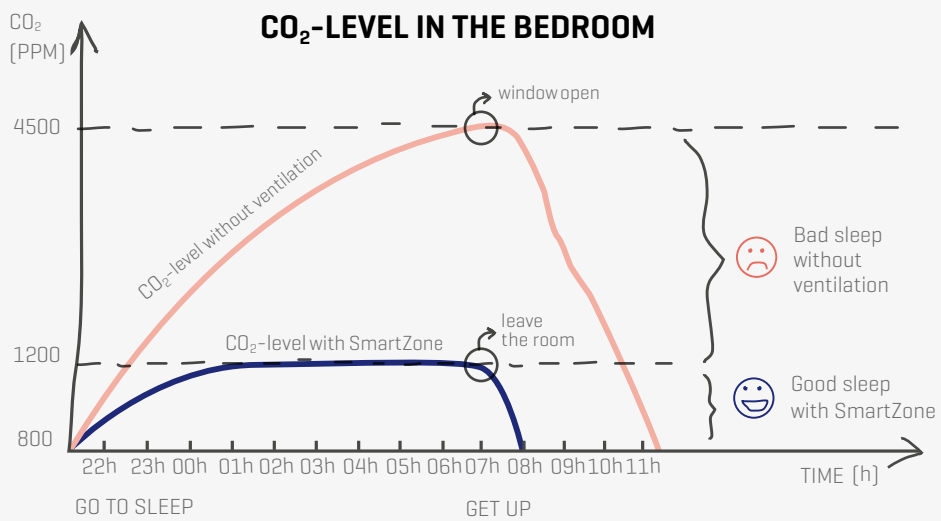

SYSTEM C+®

Healthbox® 3.0: demand & zone controlled extraction of polluted air

0,61

SMARTZONE - 0,61

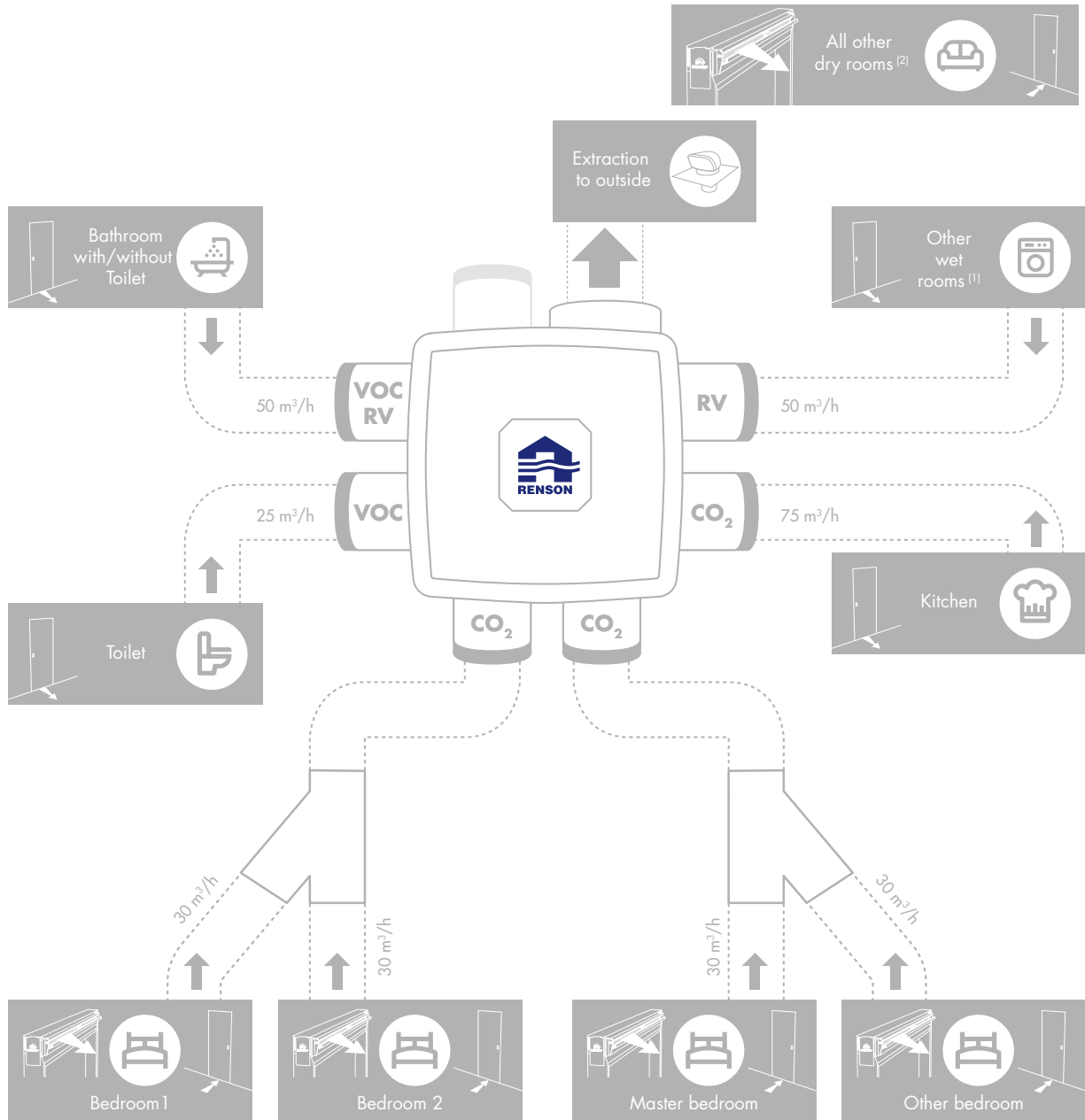

Shading factors	
$f_{\text{reduc,vent,heat}}$	= 0,61
$f_{\text{reduc,vent,cool}}$	= 1,00
$f_{\text{reduc,vent,overheat}}$	= 1,00

The valves for the bedrooms control up to 3 bedrooms. Each other valve controls a maximum of 1 local.
 RV = Relative humidity detection VOC = Volatile organic components detection CO₂ = Carbon dioxide detection
 The position of the valves can be freely determined.
 Breeze function present = demand controlled automatic deactivation in case of overheating.
 The air flows displayed are only indicative. Minimum air flow to be determined in accordance with EPB decision.
⁽¹⁾ Laundry room, drying room or analogue room
⁽²⁾ Living room, study, playroom or analogue room

Building application from
2015 onwards

Basic package Healthbox® 3.0 SmartZone

Kit Healthbox 3.0 SmartZone

1 x Healthbox 3.0 motor unit
1 x kitchen kit
1 x bathroom kit with toilet
1 x toilet kit
2 x bedroom kit

66060101



Also see page 87

Kit

Kitchen kit CO₂

66060123

Bathroom kit VOC + H₂O

66060121

Toilet kit VOC

66060122

Laundry room kit H₂O

66060120

Bedroom kit

66060124



Also see page 61

Kit valve collector

T-piece

1 x T-piece
2 x adaptor 1.25-80

66060118

Print

1 x print with casing
2 x self-tapping screw
1 x patch cable 0,5 m

66060119



Also see page 61

Cover plate

Cover plate Puro Ø80

66031630

Cover plate Puro Ø125

66031631

Cover plate Square Ø80

66031632

Cover plate Square Ø125

66031633

Cover plate Diagonal Ø80

66031634

Cover plate Diagonal Ø125

66031635

Cover plate Aqua Ø80

66031636

Cover plate Aqua Ø125

66031637

Cover plate Artist Ø80

66031638

Cover plate Artist Ø125

66031639

Cover plate Deco Ø80

66031642

Cover plate Deco Ø125

66031643

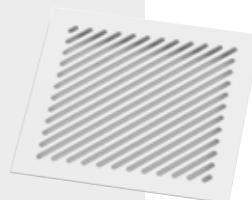

Also see page 61

Y-piece

Easyflex® Y-piece

G0013120



Also see page 61

Design valves

SQair extraction valve [Deluxe]

76050401

SQair extraction valve [Basic]

76050404



Also see page 61

SYSTEM C+®

Healthbox® 3.0: demand & zone controlled extraction of polluted air

0,50

SMARTZONE - 0,50

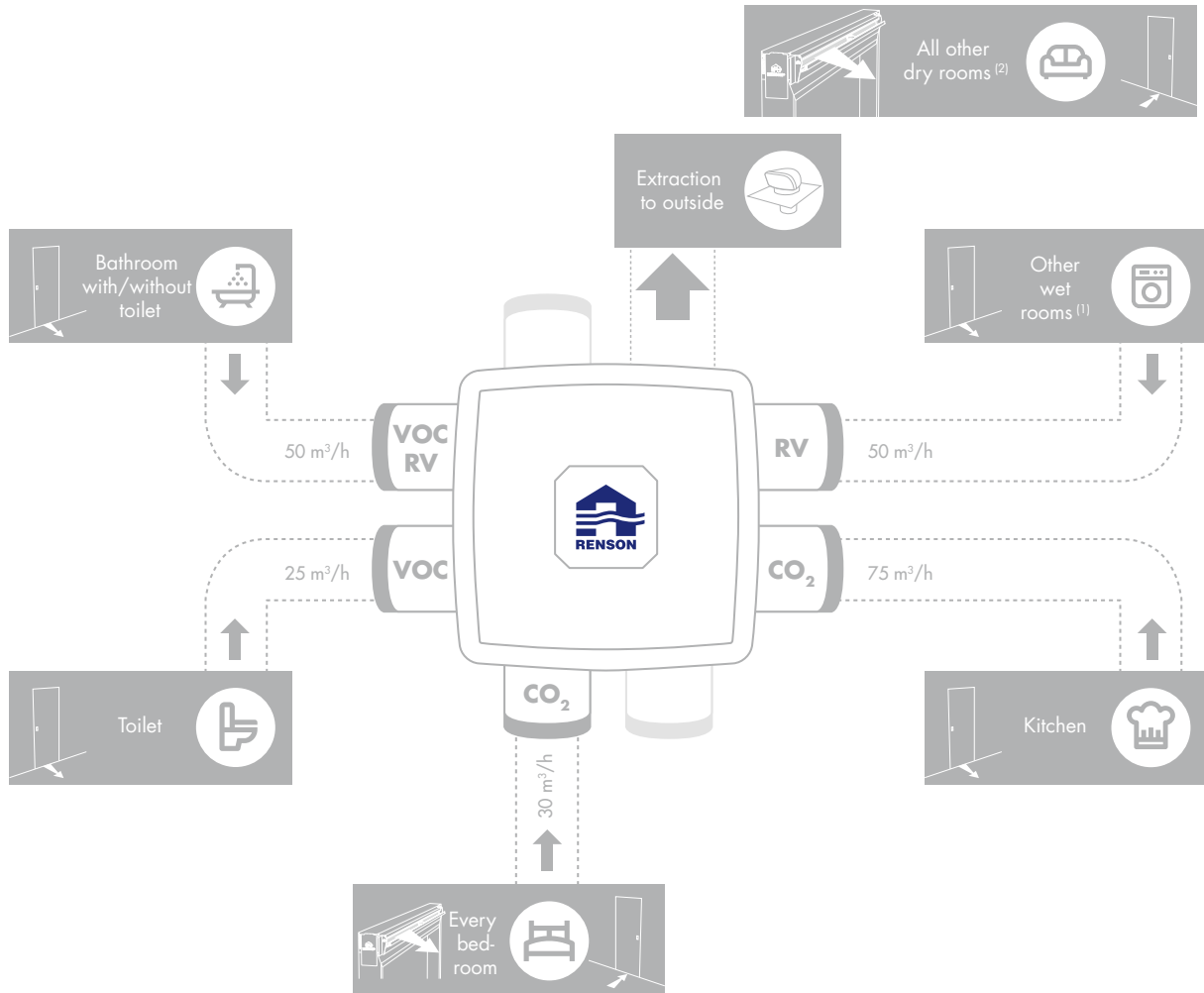

Shading factors	
$f_{\text{reduc,vent,heat}}$	= 0,50
$f_{\text{reduc,vent,cool}}$	= 1,00
$f_{\text{reduc,vent,overheat}}$	= 1,00

Each valve controls a maximum of 1 local.
 RV = Relative humidity detection VOC = Volatile organic components detection CO₂ = Carbon dioxide detection
 The position of the valves can be freely determined.
 Breeze function present = demand controlled automatic deactivation in case of overheating
 The air flows displayed are only indicative. Minimum air flow to be determined in accordance with EPB decision.
 ¹) Laundry room, drying room or analogue room
 ²) Living room, study, playroom or analogue room

Building application from 2015 onwards

Basic package Healthbox® 3.0 SmartZone

Kit Healthbox 3.0 SmartZone

1 x Healthbox 3.0 motor unit
1 x kitchen kit
1 x bathroom kit with toilet
1 x toilet kit
2 x bedroom kit

66060101



Also see page 87

Kit

Kitchen kit CO₂

66060123

Bathroom kit VOC + H₂O

66060121

Toilet kit VOC

66060122

Laundry room kit H₂O

66060120

Bedroom kit

66060124



Also see page 61

Kit valve collector

T-piece

66060118

1 x T-piece
2 x adaptor 125-80

Print

66060119

1 x print with casing
2 x self-tapping screw
1 x patch cable 0,5 m



Also see page 61

Cover plate

Cover plate Puro Ø80

66031630

Cover plate Puro Ø125

66031631

Cover plate Square Ø80

66031632

Cover plate Square Ø125

66031633

Cover plate Diagonal Ø80

66031634

Cover plate Diagonal Ø125

66031635

Cover plate Aqua Ø80

66031636

Cover plate Aqua Ø125

66031637

Cover plate Artist Ø80

66031638

Cover plate Artist Ø125

66031639

Cover plate Deco Ø80

66031642

Cover plate Deco Ø125

66031643

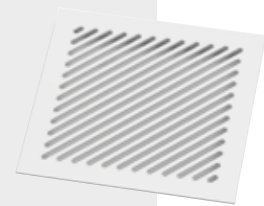

Also see page 61

Design valves

SQair extraction valve [Deluxe]

76050401

SQair extraction valve [Basic]

76050404



Also see page 61

SYSTEM C+®

Healthbox® 3.0: demand & zone controlled extraction of polluted air

0,43

SMARTZONE - 0,43

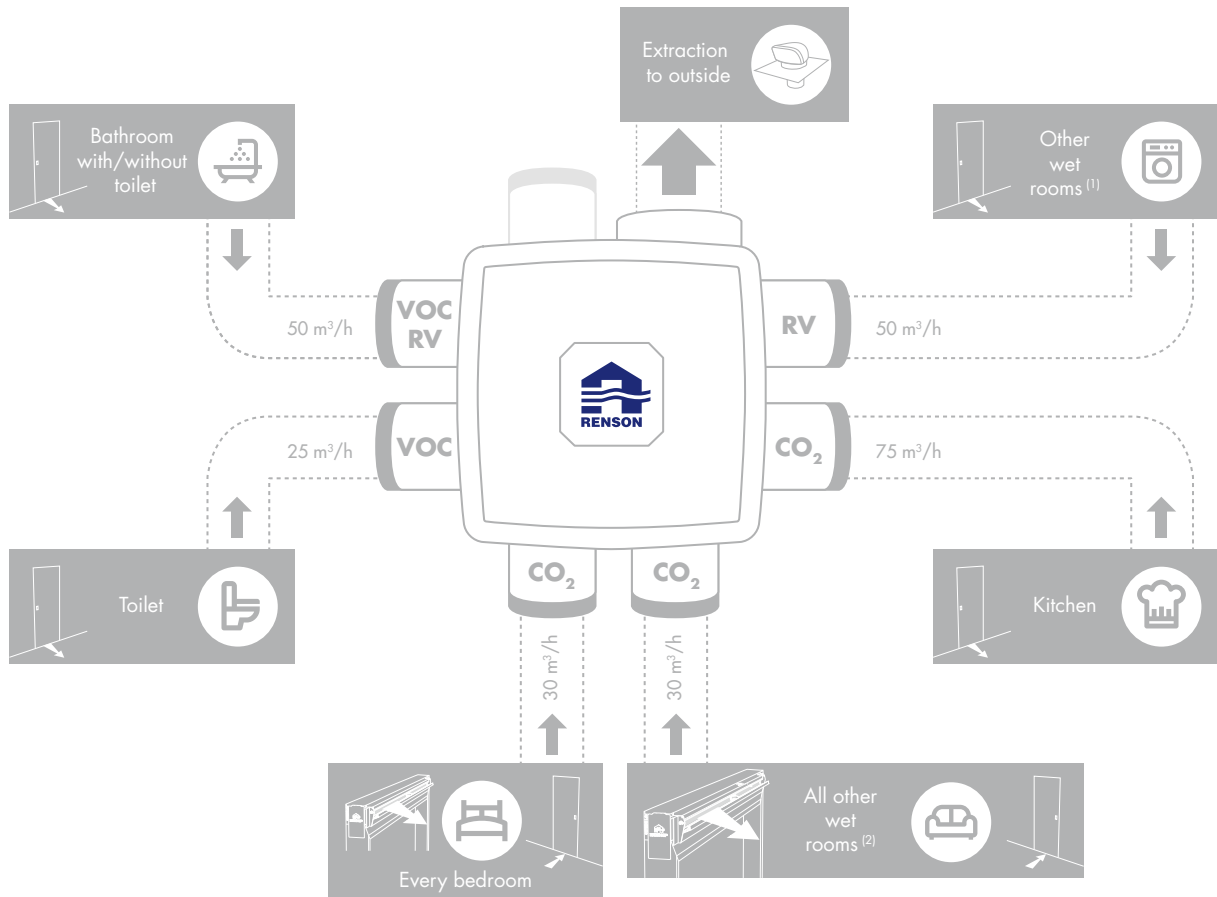

Shading factors	
$f_{\text{reduc,vent,heat}}$	= 0,43
$f_{\text{reduc,vent,cool}}$	= 1,00
$f_{\text{reduc,vent,overheat}}$	= 1,00

Each valve controls a maximum of 1 local.
 RV = Relative humidity detection VOC = Volatile organic components detection CO₂ = Carbon dioxide detection
 The position of the valves can be freely determined.
 Breeze function present = demand controlled automatic deactivation in case of overheating
 The air flows displayed are only indicative. Minimum air flow to be determined in accordance with EPB decision.
 (1) laundry room, drying room or analogue room
 (2) Living room, study, playroom or analogue room

Building application from 2015 onwards

Basic package Healthbox® 3.0 SmartZone

Kit Healthbox 3.0 SmartZone

1 x Healthbox 3.0 motor unit
1 x kitchen kit
1 x bathroom kit with toilet
1 x toilet kit
2 x bedroom kit

66060101



Also see page 87

Kit

Kitchen kit CO₂

66060123

Bathroom kit VOC + H₂O

66060121

Toilet kit VOC

66060122

Laundry room kit H₂O

66060120

Bedroom kit

66060124



Also see page 61

Kit valve collector

T-piece

66060118

1 x T-piece
2 x adaptor 125-80

Print

66060119

1 x print with casing
2 x self-tapping screw
1 x patch cable 0,5 m



Also see page 61

Cover plate

Cover plate Puro Ø80

66031630

Cover plate Puro Ø125

66031631

Cover plate Square Ø80

66031632

Cover plate Square Ø125

66031633

Cover plate Diagonal Ø80

66031634

Cover plate Diagonal Ø125

66031635

Cover plate Aqua Ø80

66031636

Cover plate Aqua Ø125

66031637

Cover plate Artist Ø80

66031638

Cover plate Artist Ø125

66031639

Cover plate Deco Ø80

66031642

Cover plate Deco Ø125

66031643

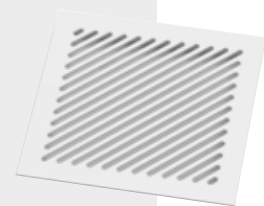

Also see page 61

Design valves

SQair extraction valve [Deluxe]

76050401

SQair extraction valve [Basic]

76050404



Also see page 61



RENEWABLE ENERGY

Nowadays, our society is almost entirely dependent on fossil fuels. Next to the fact that they are becoming scarce, they also do a great deal of damage to our planet. Energy prices are skyrocketing. It is therefore time to learn more about renewable energy sources, in order to keep heating costs affordable and to reduce the burden on the environment.

Ventilation can also contribute to this: by recovering the discharged polluted ventilation air for example. This is because air/water heat pump technology can still prove useful as an energy source for heating rooms and domestic hot water. A ventilation unit and heat pump combined in one single appliance contributes significantly to

lowering the E-level in a home and contributes to the obligation to use renewable energy. Also, a spectacularly lower energy bill and a smaller ecological footprint are a great bonus!





SYSTEM E+®

Endura® E+: demand & zone controlled extraction with heat recovery

The Renson® energy system E+ combines demand-controlled ventilation per zone with an air-water heat pump for producing domestic hot water and low temperature heating.



Endura® E+

Demand- and zone-controlled ventilation, producing domestic hot water, low temperature heating.

Technical data sheet page 87

SYSTEM E+®

Endura® E+: demand & zone controlled extraction with heat recovery

0,9

SMART - 0,90

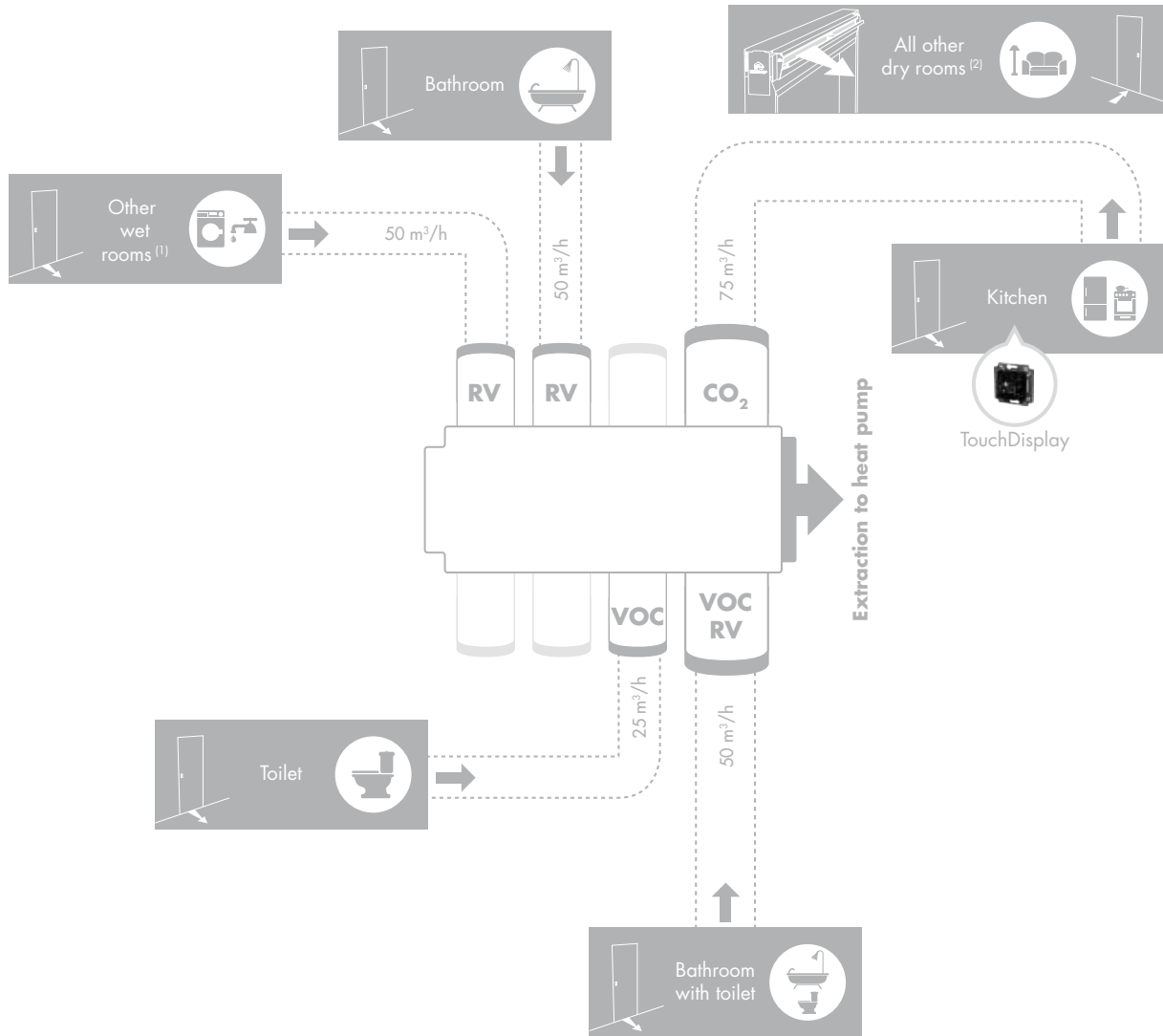

Each valve controls a maximum of 1 local.
 RV = Relative humidity detection VOC = Volatile organic components detection CO₂ = Carbon dioxide detection
 The position of the valves can be freely determined on the collector.
 Breeze function present = demand controlled automatic deactivation in case of overheating
 The air flows displayed are only indicative. Minimum air flow to be determined in accordance with EPB decision.
⁽¹⁾ Laundry room, drying room or analogue room
⁽²⁾ Living room, bedroom, study, playroom or analogue room

Shading factors	
$f_{\text{reduc,vent,heat}}$	= 0,90
$f_{\text{reduc,vent,cool}}$	= 1,00
$f_{\text{reduc,vent,overheat}}$	= 1,00

Building application from 2015 onwards

Basic package Endura®

Endura

1 x Endura 300L
1 x ventilation collector 8 connections
1 x kitchen kit
1 x bathroom kit + toilet
1 x toilet kit
1 x outdoor air exhaust
1 x TouchDisplay with CO₂
2 x filterbox
1 x coupler XYZ

76050300

Also see page 87



Kit

Kitchen kit

66031904

Bathroom kit + toilet

66031902

Toilet kit Ø80

76050303

Laundry room/bathroom kit Ø80

76050301

Cook kit

66031906

Also see page 61



TouchDisplay Endura®

Without integrated CO₂ sensor

76050322

Also see page 61



Cover plate

Cover plate Puro Ø80

66031630

Cover plate Puro Ø125

66031631

Cover plate Square Ø80

66031632

Cover plate Square Ø125

66031633

Cover plate Diagonal Ø80

66031634

Cover plate Diagonal Ø125

66031635

Cover plate Aqua Ø80

66031636

Cover plate Aqua Ø125

66031637

Cover plate Artist Ø80

66031638

Cover plate Artist Ø125

66031639

Cover plate Deco Ø80

66031642

Cover plate Deco Ø125

66031643

Also see page 61

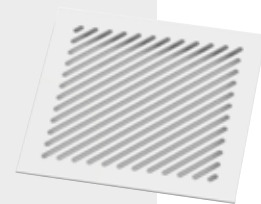

Design valves

SQair extraction valve [Deluxe]

76050401

SQair extraction valve [Basic]

76050404

Also see page 61



SYSTEM E+®

Endura® E+: demand & zone controlled extraction with heat recovery

0,61

SMARTZONE - 0,61

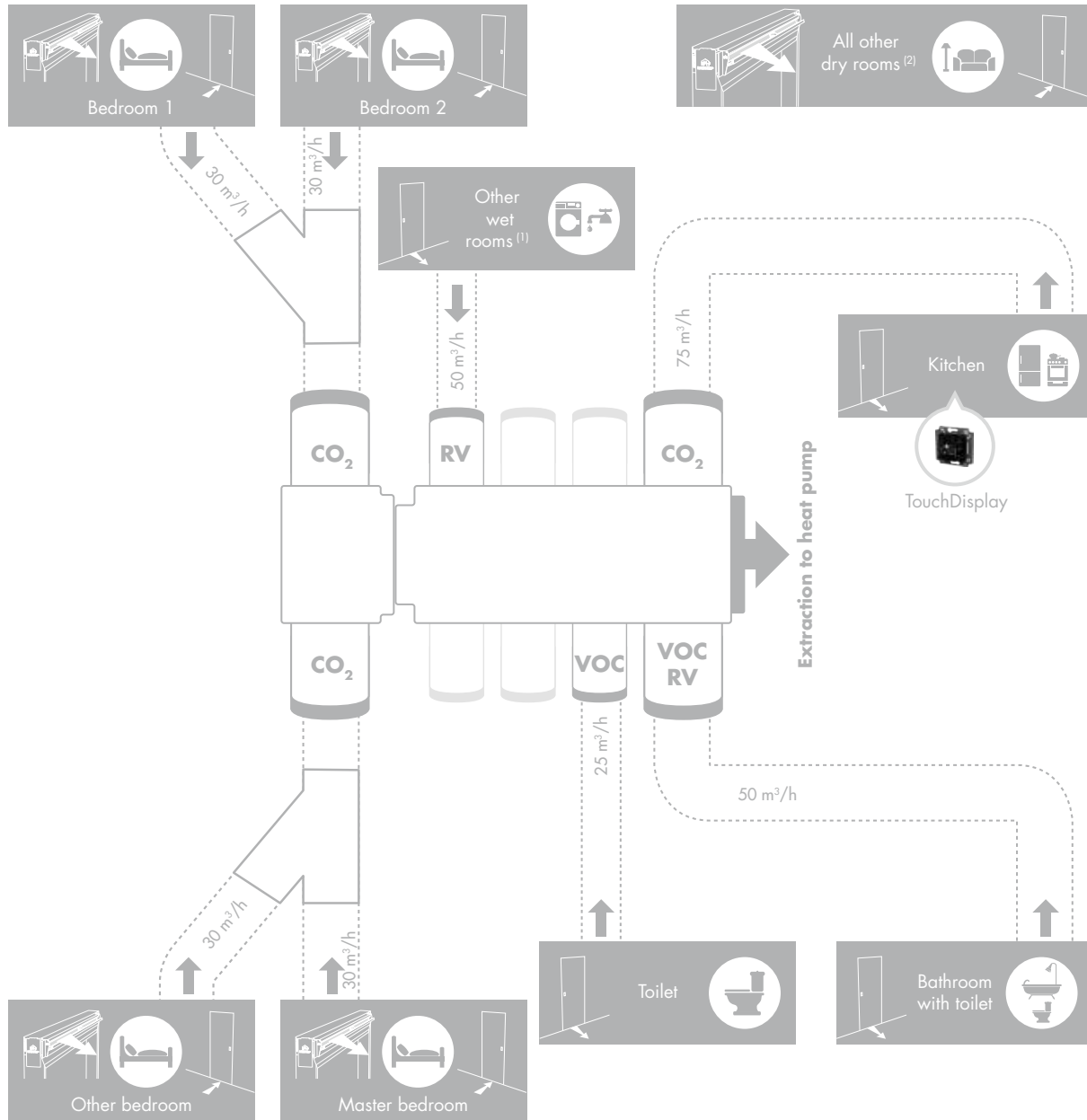

Shading factors	
$f_{\text{reduc,vent,heat}}$	= 0,61
$f_{\text{reduc,vent,cool}}$	= 1,00
$f_{\text{reduc,vent,overheat}}$	= 1,00

The valves for the bedrooms control up to 3 bedrooms. Each other valve controls a maximum of 1 local.
 RV = Relative humidity detection VOC = Volatile organic components detection CO₂ = Carbon dioxide detection
 The position of the valves can be freely determined on the collector.
 Breeze function present = demand controlled automatic deactivation in case of overheating
 The air flows displayed are only indicative. Minimum air flow to be determined in accordance with EPB decision.
 (1) laundry room, drying room or analogue room
 (2) living room, bedroom, study, playroom or analogue room

Building application from
2015 onwards

Basic package Endura®

Endura®	76050300
1 x Endura® 300L	
1 x ventilation collector 8 connections	
1 x kitchen kit	
1 x bathroom kit + toilet	
1 x toilet kit	
1 x outdoor air exhaust	
1 x TouchDisplay with CO ₂	
2 x filterbox	
1 x coupler XYZ	



Endura® SmartZone	76050310
Basic package Endura®	
2 x bedroom kit	

Also see page 87

Kit

Kitchen kit	66031904
Bathroom kit + toilet	66031902
Toilet kit Ø80	76050303
Laundry room/bathroom kit Ø80	76050301
Cook kit	66031906
Bedroom kit Ø80	76050308



Also see page 61

TouchDisplay Endura®

Without integrated CO₂ sensor	76050322
-------------------------------------------------	-----------------



Also see page 61

Cover plate

Cover plate Puro Ø80	66031630
Cover plate Puro Ø125	66031631
Cover plate Square Ø80	66031632
Cover plate Square Ø125	66031633
Cover plate Diagonal Ø80	66031634
Cover plate Diagonal Ø125	66031635
Cover plate Aqua Ø80	66031636
Cover plate Aqua Ø125	66031637
Cover plate Artist Ø80	66031638
Cover plate Artist Ø125	66031639
Cover plate Deco Ø80	66031642
Cover plate Deco Ø125	66031643

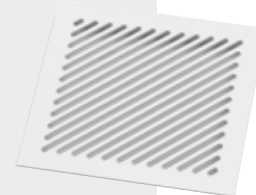

Also see page 61

Design valves

SQair extraction valve [Deluxe]	76050401
SQair extraction valve [Basic]	76050404



Also see page 61

SYSTEM E+®

Endura® E+: demand & zone controlled extraction with heat recovery

0,50

SMARTZONE - 0,50

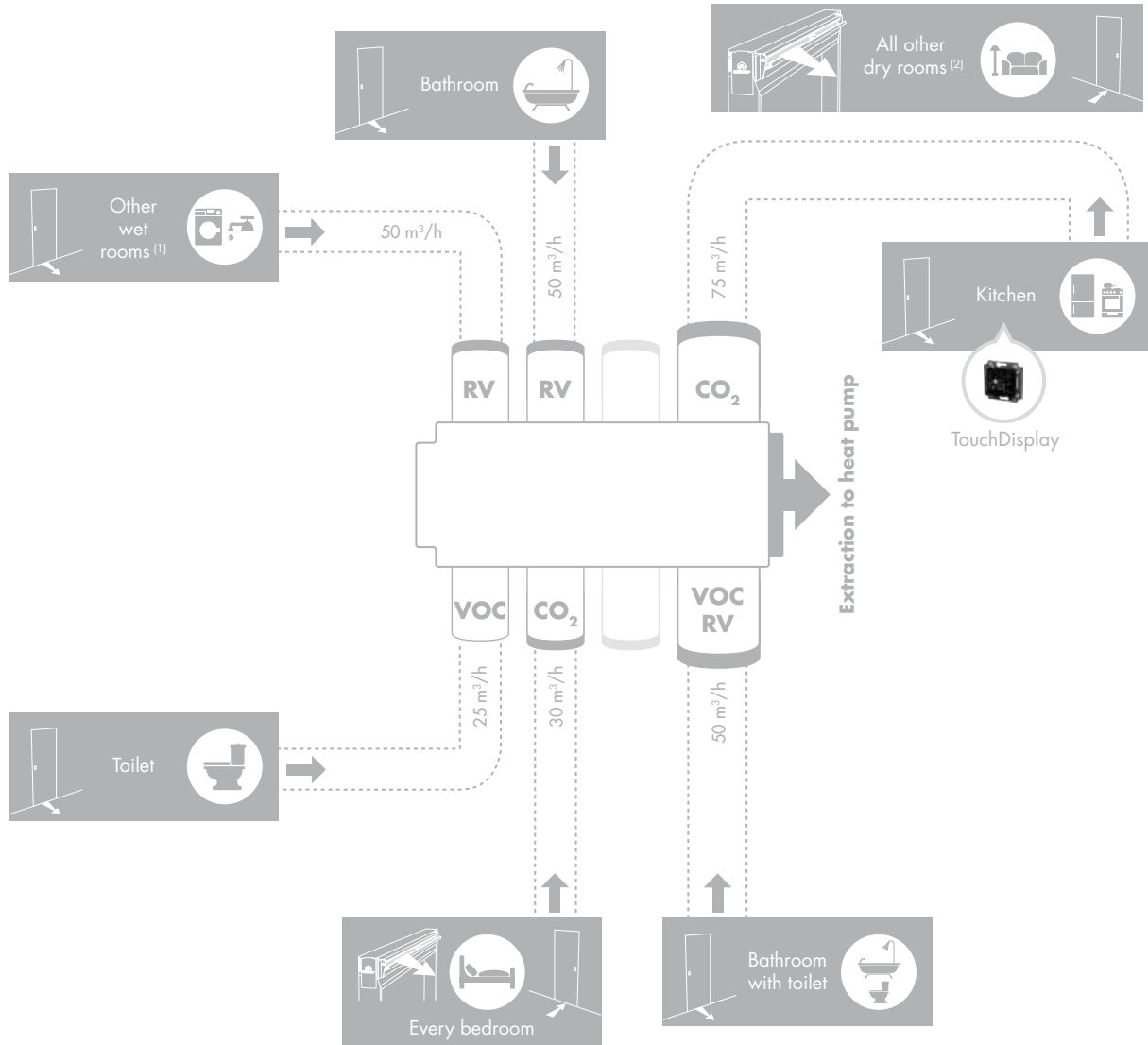

Shading factors	
$f_{\text{reduc,vent,heat}}$	= 0,50
$f_{\text{reduc,vent,cool}}$	= 1,00
$f_{\text{reduc,vent,overheat}}$	= 1,00

The valves for the bedrooms control up to 3 bedrooms. Each other valve controls a maximum of 1 local.
 RV = Relative humidity detection VOC = Volatile organic components detection CO₂ = Carbon dioxide detection
 The position of the valves can be freely determined on the collector.

Breeze function present = demand controlled automatic deactivation in case of overheating
 The air flows displayed are only indicative. Minimum air flow to be determined in accordance with EPB decision.

⁽¹⁾ Laundry room, drying room or analogue room
⁽²⁾ Living room, bedroom, study, playroom or analogue room

Building application from
 2015 onwards

Basic package Endura®

Endura®	76050300
1 x Endura® 300L	
1 x ventilation collector 8 connections	
1 x kitchen kit	
1 x bathroom kit + toilet	
1 x toilet kit	
1 x outdoor air exhaust	
1 x TouchDisplay with CO ₂	
2 x filterbox	
1 x coupler XYZ	



Endura® SmartZone	76050310
Basic package Endura®	
2 x bedroom kit	

Also see page 87

Kit

Kitchen kit	66031904
Bathroom kit + toilet	66031902
Toilet kit Ø80	76050303
Laundry room/bathroom kit Ø80	76050301
Cook kit	66031906
Bedroom kit Ø80	76050308



Also see page 61

TouchDisplay Endura®

Without integrated CO₂ sensor	76050322
-------------------------------------------------	-----------------



Also see page 61

Cover plate

Cover plate Puro Ø80	66031630
Cover plate Puro Ø125	66031631
Cover plate Square Ø80	66031632
Cover plate Square Ø125	66031633
Cover plate Diagonal Ø80	66031634
Cover plate Diagonal Ø125	66031635
Cover plate Aqua Ø80	66031636
Cover plate Aqua Ø125	66031637
Cover plate Artist Ø80	66031638
Cover plate Artist Ø125	66031639
Cover plate Deco Ø80	66031642
Cover plate Deco Ø125	66031643

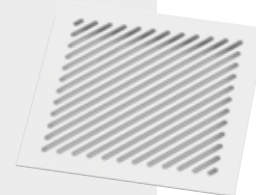

Also see page 61

Design valves

SQair extraction valve [Deluxe]	76050401
SQair extraction valve [Basic]	76050404



Also see page 61

SYSTEM E+®

Endura® E+: demand & zone controlled extraction with heat recovery

0,43

SMARTZONE - 0,43

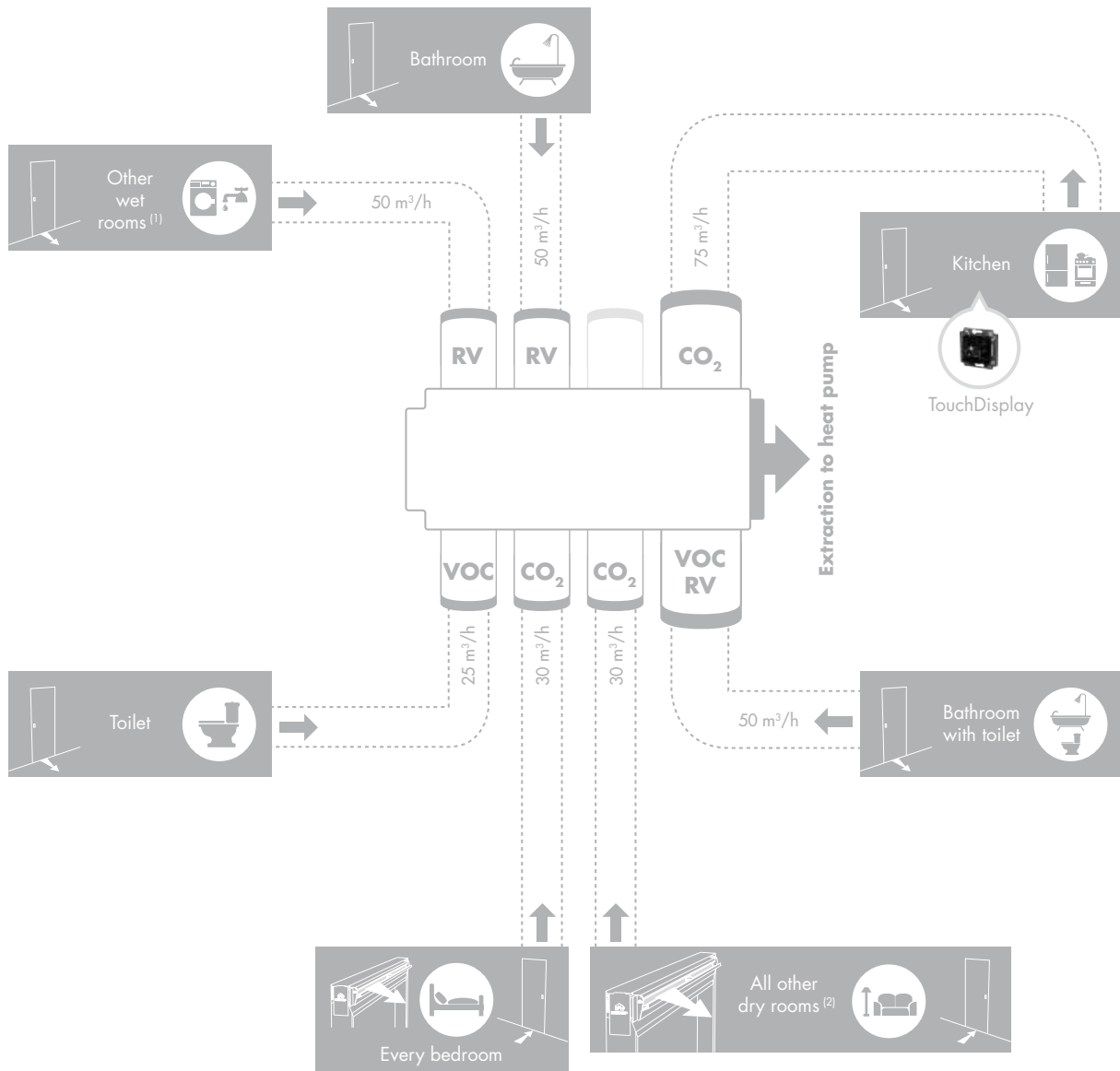

Shading factors	
$f_{\text{reduc,vent,heat}}$	= 0,43
$f_{\text{reduc,vent,cool}}$	= 1,00
$f_{\text{reduc,vent,overheat}}$	= 1,00

Each valve controls a maximum of 1 local.
 RV = Relative humidity detection VOC = Volatile organic components detection CO₂ = Carbon dioxide detection
 The position of the valves can be freely determined on the collector.
 Breeze function present = demand controlled automatic deactivation in case of overheating
 The air flows displayed are only indicative. Minimum air flow to be determined in accordance with EPB decision.
 (1) Laundry room, drying room or analogue room
 (2) Living room, bedroom, study, playroom or analogue room

Building application from 2015 onwards

Basic package Endura®

Endura®	76050300
1 x Endura® 300L	
1 x ventilation collector 8 connections	
1 x kitchen kit	
1 x bathroom kit + toilet	
1 x toilet kit	
1 x outdoor air exhaust	
1 x TouchDisplay with CO ₂	
2 x filterbox	
1 x coupler XYZ	



Endura® SmartZone	76050310
Basic package Endura®	
2 x bedroom kit	

Also see page 87

Kit

Kitchen kit	66031904
Bathroom kit + toilet	66031902
Toilet kit Ø80	76050303
Laundry room/bathroom kit Ø80	76050301
Cook kit	66031906
Bedroom kit Ø80	76050308



Also see page 61

TouchDisplay Endura®

Without integrated CO₂ sensor	76050322
-------------------------------------------------	-----------------



Also see page 61

Cover plate

Cover plate Puro Ø80	66031630
Cover plate Puro Ø125	66031631
Cover plate Square Ø80	66031632
Cover plate Square Ø125	66031633
Cover plate Diagonal Ø80	66031634
Cover plate Diagonal Ø125	66031635
Cover plate Aqua Ø80	66031636
Cover plate Aqua Ø125	66031637
Cover plate Artist Ø80	66031638
Cover plate Artist Ø125	66031639
Cover plate Deco Ø80	66031642
Cover plate Deco Ø125	66031643

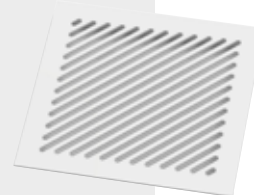

Also see page 61

Design valves

SQair extraction valve [Deluxe]	76050401
SQair extraction valve [Basic]	76050404



Also see page 61



SYSTEM D+®

Endura® Delta: demand-controlled, central ventilation with heat recovery

The Renson® D+ system is based on a combination of demand-controlled ventilation [2 fans for air supply and air extraction] and heat recovery to create a pleasant indoor climate.



- Fresh outdoor air supply
- Drainage of polluted indoor air
- Fresh outdoor air for nightcooling
- Outdoor sun protection



**Endura® Delta
330 T4**



**Endura® Delta
380 / 450 T4**



**Endura® Delta
330 T2/B2**



**Endura® Delta
380 / 450 T2/B2**

Demand-controlled, central ventilation with heat recovery.

Technical data sheet page 87

SYSTEM D+®

Endura® Delta: demand-controlled, central ventilation with heat recovery

0,93

SMART - 0,93

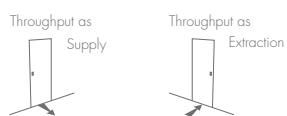
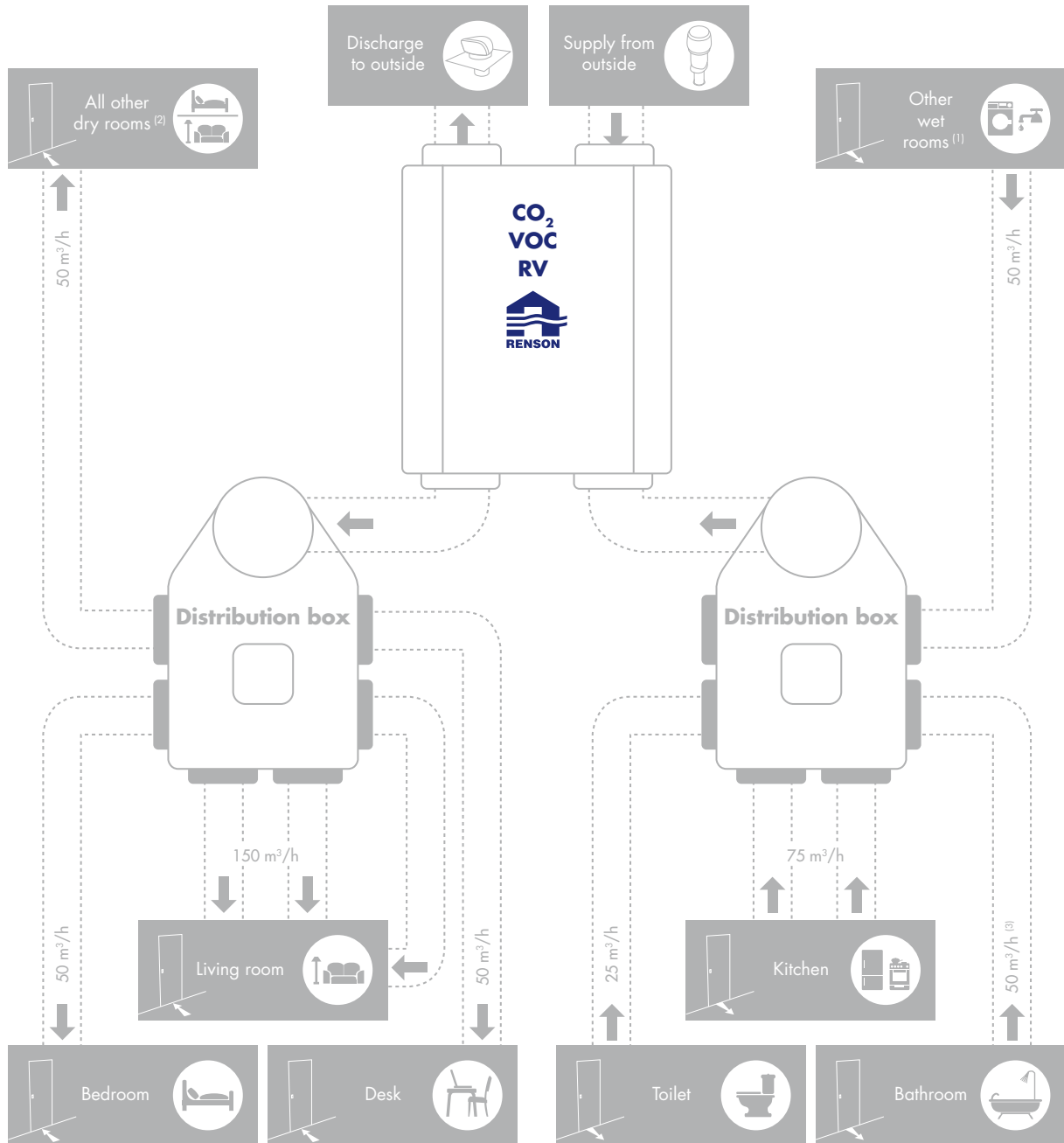

Shading factors	
$f_{\text{reduc,vent,heat}}$	= 0,93
$f_{\text{reduc,vent,cool}}$	= 1,00
$f_{\text{reduc,vent,overheat}}$	= 1,00

RV = Relative humidity detection VOC = Volatile organic components detection CO₂ = Carbon dioxide detection
The displayed air flows are only indicative. Minimum air flow to be determined in accordance with EPB decision.

⁽¹⁾ laundry room, drying room or analogue room
⁽²⁾ living room, study, playroom or analogue room
Starting at 57 m³/h split it into 2 channels for additional acoustic comfort.

Building application from 2015 onwards

Endura® Delta

ED 330 T4	76050800
ED 330 T4 PH	76050801
ED 330 T2/B2	76050802
ED 330 T2/B2 PH	76050803
ED 380 T4	76050804
ED 380 T4 PH	76050805
ED 380 T2/B2	76050806
ED 380 T2/B2 PH	76050807
ED 450 T4	76050808
ED 450 T4 PH	76050809
ED 450 T2/B2	76050810
ED 450 T2/B2 PH	76050811

Note: Standard left-version, can be easily converted to right-version
 T4 = upper connections - T2/B2 = upper and lower connections - PH = with preheater.
 Also see page 87

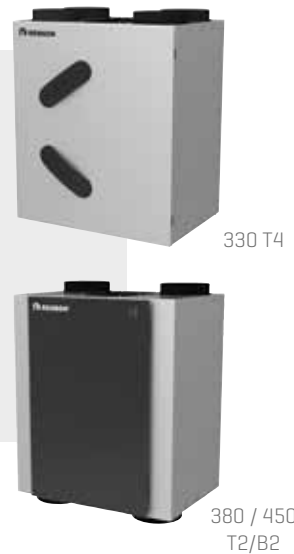

Filters

Coarse [G4] filter cassette - coarse filter	76015650
ePM1 [F7] filter cassette - fine / pollen filter	76015651
Coarse [G4] filter cassette + activated carbon filter	76015652



Also see page 87

Mounting base

Mounting base Endura Delta	76050558
----------------------------	----------



Also see page 87

Design valves

SQair supply valve [Deluxe]	76050400
SQair extraction valve [Deluxe]	76050401
SQair supply valve [Basic]	76050403
SQair extraction valve [Basic]	76050404
Filter SQair pulsion	76050406



Also see page 61

Distribution box

Easyflex® distribution box angled 160 6 fastening brackets included	60013135
Easyflex® distribution box straight 160 6 fastening brackets included	60013140
Easyflex® distribution box 8 connections 8 fastening brackets included	60013136
Easyflex® straight double adaptor ø125	60013141



Also see page 61

SYSTEM D+®

Endura® Delta: demand-controlled, central ventilation with heat recovery

0,87

SENSE - 0,87

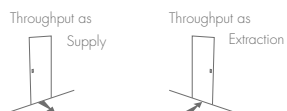
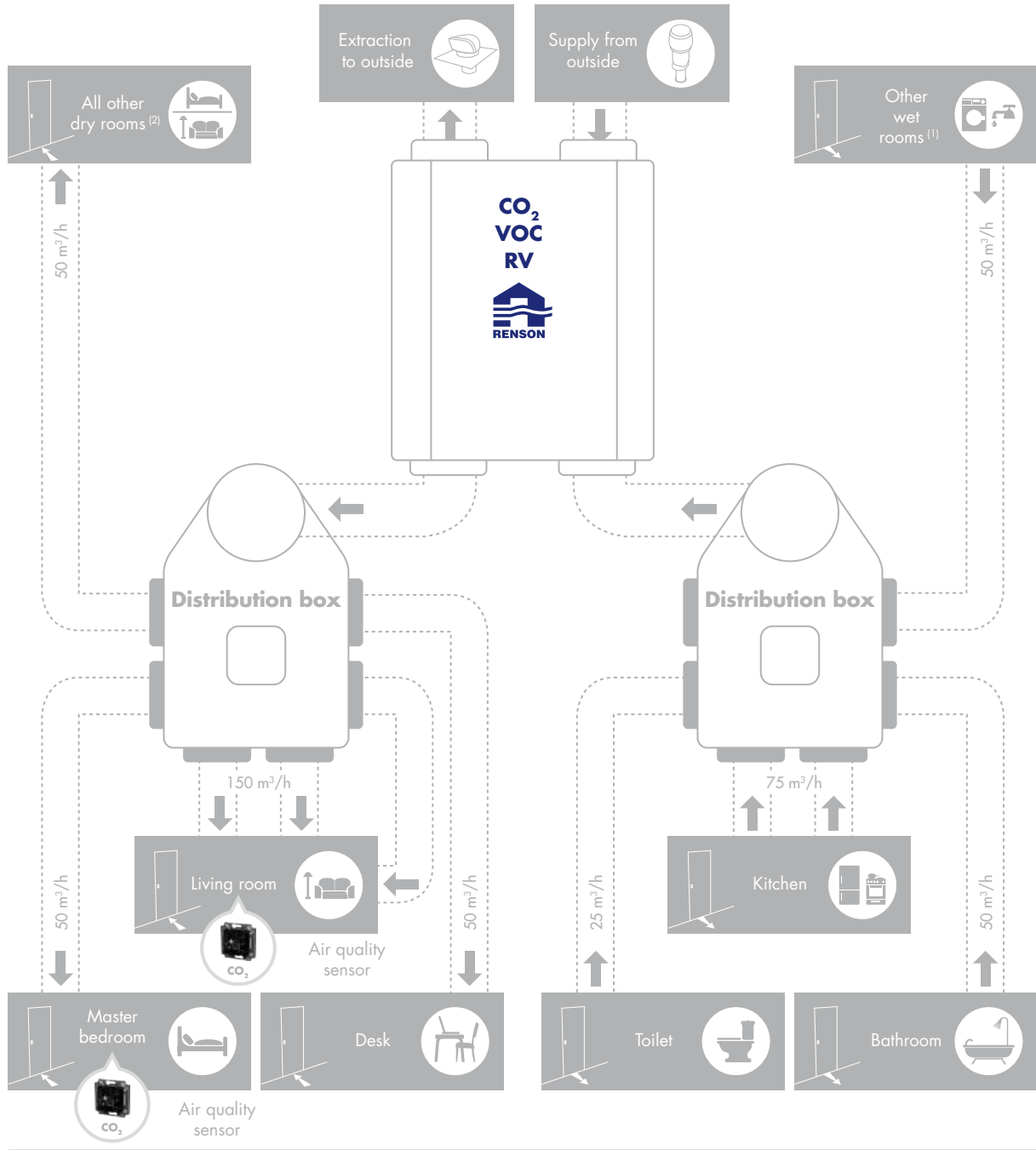

Shading factors	
$f_{\text{reduc,vent,heat}}$	= 0,87
$f_{\text{reduc,vent,cool}}$	= 1,00
$f_{\text{reduc,vent,overheat}}$	= 1,00

RV = Relative humidity detection VOC = Volatile organic components detection CO₂ = Carbon dioxide detection
 The displayed air flows are only indicative. Minimum air flow to be determined in accordance with EPB decision.
 (1) Laundry room, drying room or analogue room
 (2) Study, playroom or analogue room
 Starting at 57 m³/h split it into 2 channels for additional acoustic comfort.
 Applicable if the living room and master bedroom are equipped with an air quality sensor.

Building application from 2015 onwards

Endura® Delta

ED 330 T4	76050800
ED 330 T4 PH	76050801
ED 330 T2/B2	76050802
ED 330 T2/B2 PH	76050803
ED 380 T4	76050804
ED 380 T4 PH	76050805
ED 380 T2/B2	76050806
ED 380 T2/B2 PH	76050807
ED 450 T4	76050808
ED 450 T4 PH	76050809
ED 450 T2/B2	76050810
ED 450 T2/B2 PH	76050811

Note: Standard left-version, can be easily converted to right-version
 T4 = upper connections - T2/B2 = upper and lower connections - PH = with preheater
 Also see page 87



Filters

Coarse [G4] filter cassette - coarse filter	76015650
ePM1 [F7] filter cassette - fine / pollen filter	76015651
Coarse [G4] filter cassette + activated carbon filter	76015652

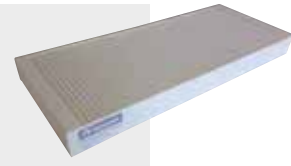

Also see page 87

Mounting base

Mounting base Endura Delta	76050558
----------------------------	----------



Also see page 87

Design valves

SQair supply valve [Deluxe]	76050400
SQair extraction valve [Deluxe]	76050401
SQair supply valve [Basic]	76050403
SQair extraction valve [Basic]	76050404
Filter SQair pulsion	76050406



Also see page 61

Distribution box

Easyflex® distribution box angled 160 6 fastening brackets included	60013135
Easyflex® distribution box straight 160 6 fastening brackets included	60013140
Easyflex® distribution box 8 connections 8 fastening brackets included	60013136
Easyflex® straight double adaptor ø125	60013141



Also see page 61

Air quality sensor

Master air quality sensor Wired connection to Endura Delta RS232 connection [data]	76050330
Slave air quality sensor Wireless communication with Master air quality Sensor 230V	76050331



Also see page 61

SYSTEM D+®

Endura® Delta: demand-controlled, central ventilation with heat recovery

0,70

SENSE - 0,70

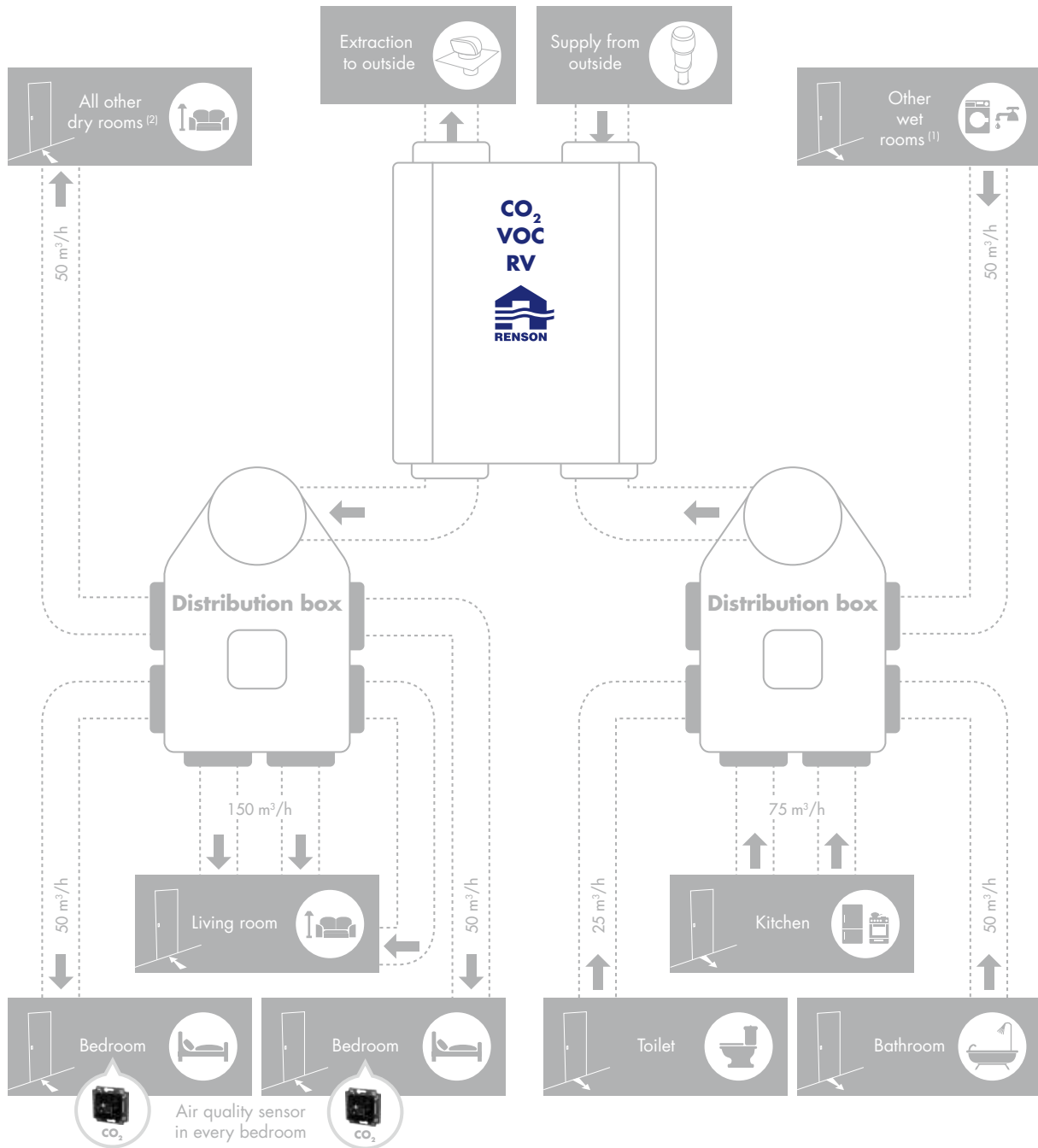

Shading factors	
$f_{\text{reduc,vent,heat}}$	= 0,70
$f_{\text{reduc,vent,cool}}$	= 1,00
$f_{\text{reduc,vent,overheat}}$	= 1,00

RV = Relative humidity detection VOC = Volatile organic components detection CO₂ = Carbon dioxide detection
 The displayed air flows are only indicative. Minimum air flow to be determined in accordance with EPB decision.
 (1) Laundry room, drying room or analogue room
 (2) Study, playroom or analogue room
 Starting at 57 m³/h split it into 2 channels for additional acoustic comfort.
 Applicable if all bedrooms are individually equipped with an air quality sensor.

Building application from 2015 onwards

Endura® Delta

ED 330 T4	76050800
ED 330 T4 PH	76050801
ED 330 T2/B2	76050802
ED 330 T2/B2 PH	76050803
ED 380 T4	76050804
ED 380 T4 PH	76050805
ED 380 T2/B2	76050806
ED 380 T2/B2 PH	76050807
ED 450 T4	76050808
ED 450 T4 PH	76050809
ED 450 T2/B2	76050810
ED 450 T2/B2 PH	76050811

Note: Standard left-version, can be easily converted to right-version
 T4 = upper connections - T2/B2 = upper and lower connections - PH = with preheater
 Also see page 87



Filters

Coarse [G4] filter cassette - coarse filter	76015650
ePM1 [F7] filter cassette - fine / pollen filter	76015651
Coarse [G4] filter cassette + activated carbon filter	76015652

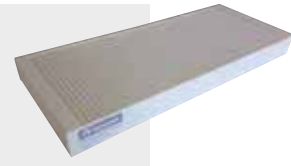

Also see page 87

Mounting base

Mounting base Endura Delta	76050558
-----------------------------------	-----------------



Also see page 87

Design valves

SQair supply valve [Deluxe]	76050400
SQair extraction valve [Deluxe]	76050401
SQair supply valve [Basic]	76050403
SQair extraction valve [Basic]	76050404
Filter SQair pulsion	76050406



Also see page 61

Distribution box

Easyflex® distribution box angled 160	60013135
6 fastening brackets included	
Easyflex® distribution box straight 160	60013140
6 fastening brackets included	
Easyflex® distribution box 8 connections	60013136
8 fastening brackets included	
Easyflex® straight double adaptor ø125	60013141



Also see page 61

Air quality sensor

Master air quality sensor	76050330
Wired connection to Endura Delta RS232 connection [data]	
Slave air quality sensor	76050331
Wireless communication with Master air quality Sensor 230V	



Also see page 61

SYSTEM D+®

Endura® Delta: demand-controlled, central ventilation with heat recovery

0,61

SENSE - 0,61

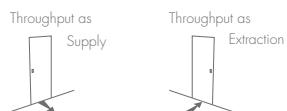
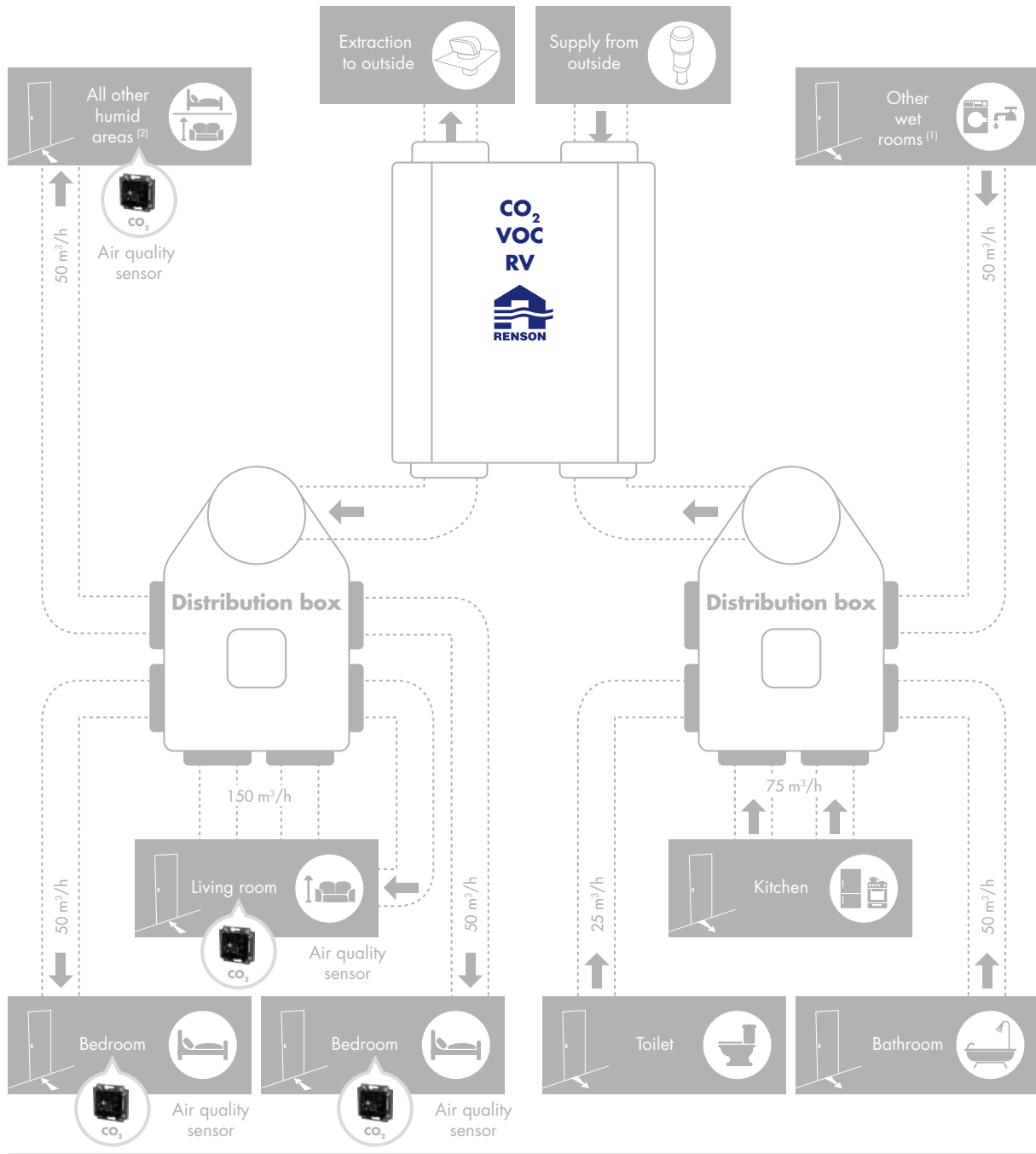

Shading factors	
$f_{\text{reduc,vent,heat}}$	= 0,61
$f_{\text{reduc,vent,cool}}$	= 1,00
$f_{\text{reduc,vent,overheat}}$	= 1,00

RV = Relative humidity detection VOC = Volatile organic components detection CO₂ = Carbon dioxide detection
 The displayed air flows are only indicative. Minimum air flow to be determined in accordance with EPB decision.
 !!! Laundry room, drying room or analogue room
 !! Study, playroom or analogue room
 Starting at 57 m³/h split into 2 channels for additional acoustic comfort.
 Valid if all dry areas are equipped with an air quality sensor.

Building application from 2015 onwards

Endura® Delta

ED 330 T4	76050800
ED 330 T4 PH	76050801
ED 330 T2/B2	76050802
ED 330 T2/B2 PH	76050803
ED 380 T4	76050804
ED 380 T4 PH	76050805
ED 380 T2/B2	76050806
ED 380 T2/B2 PH	76050807
ED 450 T4	76050808
ED 450 T4 PH	76050809
ED 450 T2/B2	76050810
ED 450 T2/B2 PH	76050811

Note: Standard left-version, can be easily converted to right-version
 T4 = upper connections - T2/B2 = upper and lower connections - PH = with preheater
 Also see page 87

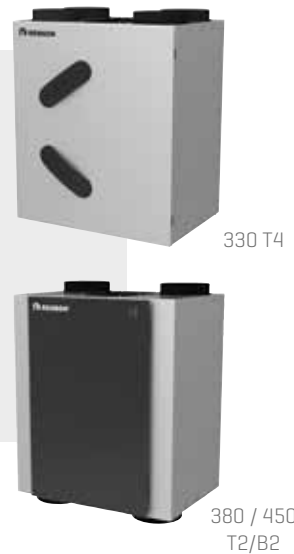

Filters

Coarse [G4] filter cassette - coarse filter	76015650
ePM1 [F7] filter cassette - fine / pollen filter	76015651
Coarse [G4] filter cassette + activated carbon filter	76015652

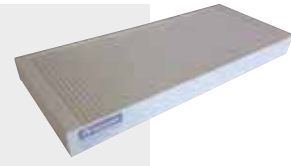

Also see page 87

Mounting base

Mounting base Endura Delta	76050558
-----------------------------------	-----------------



Also see page 87

Design valves

SQair supply valve [Deluxe]	76050400
SQair extraction valve [Deluxe]	76050401
SQair supply valve [Basic]	76050403
SQair extraction valve [Basic]	76050404
Filter SQair pulsion	76050406



Also see page 61

Distribution box

Easyflex® distribution box angled 160	G0013135
6 fastening brackets included	
Easyflex® distribution box straight 160	G0013140
6 fastening brackets included	
Easyflex® distribution box 8 connections	G0013136
8 fastening brackets included	
Easyflex® straight double adaptor ø125	G0013141



Also see page 61

Air quality sensor

Master air quality sensor	76050330
Wired connection to Endura Delta RS232 connection [data]	
Slave air quality sensor	76050331
Wireless communication with Master air quality Sensor 230V	



Also see page 61



HEALTHCONNECTOR®

In schools, hospitals, office buildings, etc. the indoor climate is of crucial importance. The Healthconnector can be combined with any constantly pressure-controlled ventilation system (extraction or pulse), to create a demand-controlled ventilation system, based on CO₂ and relative humidity control.

Healthconnector Ø125 Master

Max 125m³/h
CO₂ & H₂O sensors

66025092



Healthconnector Ø125 Slave

Max 125m³/h

66025093



Healthconnector Ø200 Master

Max 400 m³/h
CO₂ & H₂O sensors

66025082



Healthconnector Ø200 Slave

Max 400 m³/h

66025083



Healthconnector Ø250 Master

Max 600 m³/h
CO₂ & H₂O sensors

66025087



Healthconnector Ø250 Slave

Max 600 m³/h

66025088





ACCESSORIES

Our ventilation systems are delivered in kit-packaging, so that you always have all the right parts for a successful installation. Renson® also offers an extensive range of accessories to ensure that every installation can be completed successfully.

Easyflex®	p. 63
Kits Healthbox® 3.0	p. 66
Kits ø125 & ø80 Endura® E+	p. 67
Controls	p. 69
Sensors	p. 70
Accessories Xtravent EcoModus Compact	p. 71
Accessories Endura®	p. 72
Design extraction louvres	p. 75
Accessories design extraction louvres	p. 77
SQair valve	p. 79
Connection accessories	p. 80
Roof exhausts	p. 82
Easyduct	p. 84
CO ₂ monitor	p. 85



EASYFLEX®

Technical data sheet see page 87

Easyflex® flexible duct

Flat oval 140 x 64 mm
Roll 15 m

G0013110



Easyflex® flat oval duct

Flat oval 135 x 55 mm
3 m

G0013126



Easyflex® flexible connection piece

Flat oval 140 x 64 mm

G0013139



Easyflex® round duct ø125

3 m

G0013130



Easyflex® round duct ø80

3 m

G0013131



Easyflex® extension piece ø125

0,25 m

G0013132



Easyflex® extension piece ø80

0,25 m

G0013133



Easyflex® crosspiece pivot

G0013145



EASYFLEX®

Technical data sheet see page 87

Easyflex® double valve connection $\varnothing 125$

G0013118



Easyflex® valve connection $\varnothing 125$

G0013117



Easyflex® valve connection $\varnothing 80$

G0013116



Easyflex® adaptor flat to round 140 x 60 > $\varnothing 125$

G0013124



Easyflex® straight double adaptor 2 x 140 x 60 > $\varnothing 125$

G0013141



Easyflex® adaptor flat to round 140 x 60 > $\varnothing 80$

G0013123



Easyflex® Y-piece

G0013120



Easyflex® vertical bend 90°

G0013114



Easyflex® horizontal bend 90°

G0013113



Easyflex® connector with integrated rubber gaskets, flat **G0013111**



Easyflex® connector with integrated rubber gaskets, ø125 **G0013122**



Easyflex® connector with integrated rubber gaskets, ø80 **G0013121**



Easyflex® quick fastener

G0013112



Easyflex® metal fastening bracket

G0013137



Easyflex® fastening bracket

G0013115



Easyflex® distribution box angled 160

G0013135

6 connections, 6 metal fastening brackets

Easyflex® distribution box straight 160

G0013140

6 connections, 6 metal fastening brackets

Easyflex® distribution box 8 connections

G0013136

8 connections, 8 metal fastening brackets



Easyflex® inspection hatch

76050405



Easyflex® insulation tube

66031400

2 m



KITS HEALTHBOX® 3.0

Kitchen kit

66060123

Kitchen valve
Grill base Ø125 + plaster cardboard
Strap Ø60-165
0.5m patch cable



Bathroom kit

66060121

Bathroom valve
Grill base Ø125 + plaster cardboard
Strap Ø60-165
0.5m patch cable



Toilet kit

66060122

Toilet valve
Grill base Ø80 + plaster cardboard
Strap Ø50-90
0.5m patch cable



Laundry room kit

66060120

Laundry room valve
Grill base Ø125 + plaster cardboard
Strap Ø60-165
0.5m patch cable



Bedroom kit

66060124

Bedroom valve
Grill base Ø125 + plaster cardboard
Strap Ø60-165
0.5m patch cable



KITS Ø125 - ENDURA® E+

Kitchen kit

66031904

Kitchen valve
Grill base Ø125 + plaster cardboard
Strap Ø60-165
0.5m patch cable

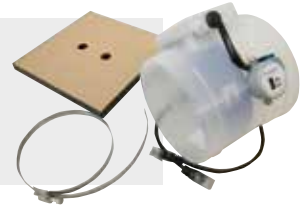

Bathroom kit + toilet

66031902

Bathroom valve + toilet
Grill base Ø125 + plaster cardboard
Strap Ø60-165
0.5m patch cable

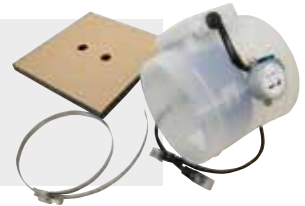

Toilet kit

66031903

Toilet valve
Grill base Ø80 + plaster cardboard
Strap Ø50-90
0.5m patch cable

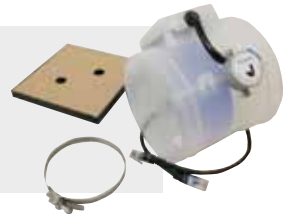

Laundry room/bathroom kit

66031901

Laundry room/bathroom valve
Grill base Ø80 + plaster cardboard
Strap Ø50-90
0.5m patch cable

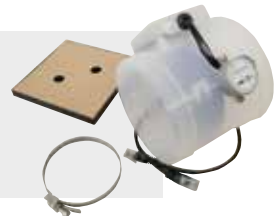

Cook kit

66031906

Cook valve
Grill base Ø125 + plaster cardboard
Strap Ø60-165
0.5m patch cable

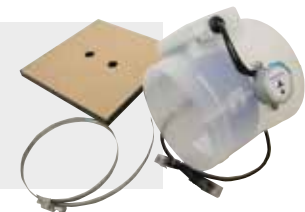

Bedroom kit

66031908

Bedroom valve
Grill base Ø125 + plaster cardboard
Strap Ø60-165
0.5m patch cable



KITS Ø80 - ENDURA® E+

The Ø80 kits can only be used on the collector of the Endura demand-controlled ventilation system with integrated heat pump.

Toilet kit

76050303

Toilet valve
Grill base Ø80 + plaster cardboard
Strap Ø50-90
0.5m patch cable



Laundry room/bathroom kit

76050301

Laundry room/bathroom valve
Grill base Ø80 + plaster cardboard
Strap Ø50-90
0.5m patch cable



Bedroom kit

76050308

Bedroom valve
Grill base Ø125 + plaster cardboard
Strap Ø60-165
0.5m patch cable



CONTROLS

Each Renson® system can be controlled with specific controls. This enables the user to operate every device optimally and, if possible, also receives the necessary feedback.

XVK3 switch

Control

66014049

3-position switch with rotary switch
Built-in switch
Cover plate type NIKO 'Intense', colour 'Sterling'
Connection cable: min. 4 x 0,8 mm² / max. 4 x 1,5 mm²
Compatible with Cbase® / Xtravent® EcoModus Compact / Healthbox® 3.0



XVK4 switch

Control

66016446

4-position switch with push button
Built-in switch
NIKO with claw mount
Cover plate type NIKO 'Intense', colour 'Sterling'
Connection cable: min. 10 x 0,34 mm² / max. 10 x 0,8 mm²
Compatible with Healthbox® II / Healthbox® II Compact / Healthbox® II SmartZone / Healthconnector



TouchDisplay with CO₂ sensor

TouchDisplay HB with CO₂ sensor

66031830

TouchDisplay Cube® with CO₂ sensor

66032202

TouchDisplay with integrated CO₂ sensor
Wireless communication
Cover plate not included
230V



Sensorless TouchDisplay

Sensorless TouchDisplay HB

66031828

Sensorless TouchDisplay Cube®

66032203

TouchDisplay Endura®

76050322

Sensorless TouchDisplay
Wireless communication
Cover plate not included
230V



Timer control

Timer

66031807

Control with adjustable time
Interval wireless
Compatible with Healthbox® II / Healthbox® II Compact / Healthbox® SmartZone / Cube®
Cover plate white
230V



SENSORS

Some ventilation systems can optionally be equipped with additional sensors. As a result, the air quality or residents' presence is measured locally in order to adjust ventilation air flow accordingly.

Master air quality sensor

Master air quality sensor

76050330

TouchDisplay with integrated CO₂ sensor
RS232 connection (not connected to Endura® Delta)
Compatible with Endura® Delta
Cover plate not included



Slave air quality sensor

Slave air quality sensor

76050331

TouchDisplay with integrated CO₂ sensor
Wireless communication
230V
Compatible with Endura® Delta
Cover plate not included



Motion sensor

XVKS motion sensor

66031720

1 x XVKS motion sensor white
Compatible with Cube®
Cover plate not included

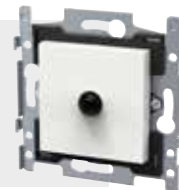

XTRAVENT ACCESSORIES

ECOMODUS COMPACT

PH75 Kitchen/Bathroom kit

Extraction PH75 + mounting flange
Humidity and presence detection
Ø80 mm

66014030



PT25 Toilet kit

Extraction PT25 + mounting flange
Humidity detection + timer
Ø80 mm

66014040



H50 Washing area kit

Extraction H50 + mounting flange
Humidity detection
Ø80 mm

66014050



Power supply card 12VAC-9VDC

12VAC - 9VDC
Can be combined with PH75 and PT25

66014090

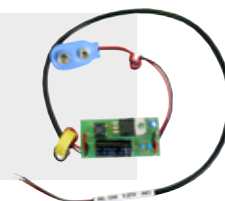

Transformer

12VAC 12VA with fuse

66014091



ENDURA E+ ACCESSORIES

Technical data sheet see page 87

EPP ventilation collector 8 connections

76050311

Collector 8 connections 6 x Ø80 + 2 x Ø125
2 x cover cap Ø125/150 + 5 x cover cap Ø80
2 x suspension bracket + 1 x extension suspension bracket
2 x tension belt 9x750 mm
2 x cover cap valve Ø125 + 6 x cover cap valve Ø80



EPP ventilation collector 2 connections Ø80

76050312

Collector 2 connections Ø80
1 x cover cap Ø125/150 + 1 x cover cap Ø80
2 x suspension bracket + 1 x extension suspension bracket
2 x tension belt 9x750 mm
2 x cover cap valve Ø80



EPP ventilation collector 2 connections Ø125

76050313

Collector 2 connections Ø125
2 x cover cap Ø125/150
2 x suspension bracket + 1 x extension suspension bracket
2 x tension belt 9x750 mm
2 x cover cap valve Ø125



EPP coupler XYZ [4xØ150]

76015013

1 x XYZ coupler
1 x cover cap Ø125/150



EPP outdoor air valve

76050316

Ø150



EPP filterbox Ø150

76015015

1 x filterbox Ø150
1 x frame with G2 filter



Replacement filter for filterbox
2 x cleanable filter 20ppi (G2 filter class)

76015016

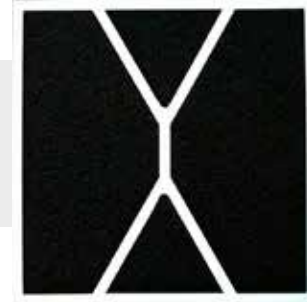

EPP cover cap Ø80
10 x cover cap Ø80

76050314

EPP cover cap Ø125/150
5 x cover cap Ø125/150

76050315



Data cable + power
Data cable (shielded) + power
Ø6,8
Black - 50m
Impedance 120°

76050318



Suspension bracket Ø180
10 x suspension bracket
10 x extension suspension bracket
10 x tension belt 9x750 mm

76015017



Tension belt 9x750 mm
100 pieces

76050317



Cover cap valve Ø125
Cover cap valve Ø80

66031762
66031762



EPP mounting kit on wall louvres

Adhesion primer 500ml
Glue 310ml

76015030
76015031





DESIGN EXTRACTION LOUVRES

Technical data sheet see page 87

All Renson® design extraction louvres consist of 2 parts: a grill frame and a cover plate. The grill frames are available in 2 diameters (Ø80 mm and Ø125 mm) and in 2 versions (modular or non modular). With Healthbox II / Compact / SmartZone and Endura 300, the black grill frame is included in the kit and you only need to purchase a cover plate. With Healthbox 3.0, the white grill frame is included in the kit.

Grill frame Ø80

Ø80 black
Ø80 white

66031626
66031675

1 x grill frame Ø80
1 x plaster cardboard

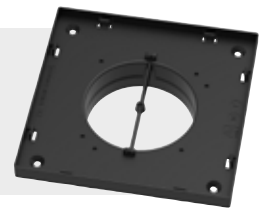

Grill frame Ø125

Ø125 black
Ø125 white

66031627
66031676

1 x grill frame Ø125
1 x plaster cardboard

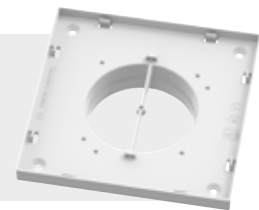

Modular grill frame Ø80

Ø80 black
Ø80 white

66031624
66031687

1 x grill frame Ø80
1 x plaster cardboard



Modular grill frame Ø125

Ø125 black
Ø125 white

66031625
66031686

1 x grill frame Ø125
1 x plaster cardboard

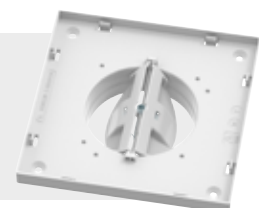

DESIGN EXTRACTION LOUVRES

Technical data sheet see page 87

Cover plate Puro

Ø80
Ø125

66031630
66031631

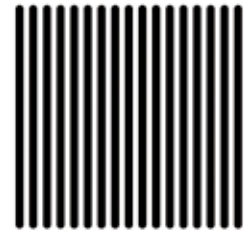

Cover plate Square

Ø80
Ø125

66031632
66031633

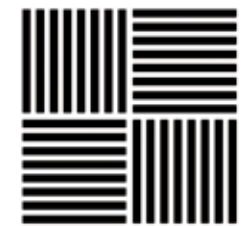

Cover plate Diagonal

Ø80
Ø125

66031634
66031635

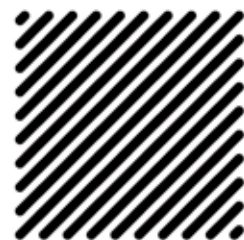

Cover plate Aqua

Ø80
Ø125

66031636
66031637

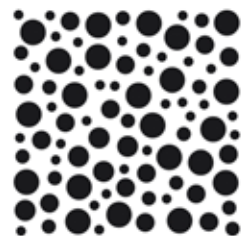

Cover plate Artist

Ø80
Ø125

66031638
66031639

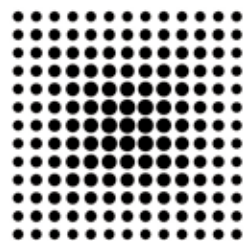

Cover plate Deco

Ø80
Ø125

66031642
66031643



ACCESSORIES DESIGN EXTRACTION LOUVRES

The gypkit and panel kit can be used with the Renson® design valves in plastering in a plaster wall/ceiling or panel wall.

Gypkit Ø80 mm

66031622

Can be combined with grill frame Ø80
For plasterboard 9.5-12.5 mm
Incl. fixing screws (11 pieces) for gypkit, grill frame and angular bend



Gypkit Ø125 mm

66031623

Can be combined with grill frame Ø125
For plasterboard 9.5-12.5 mm
Incl. fixing screws (11 pieces) for gypkit, grill frame and angular bend

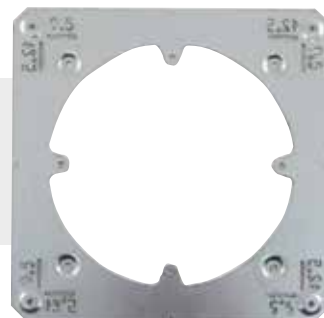

Panel kit Ø80 mm

66031620

Can be combined with grill frame Ø80
For panel thickness 5-30 mm
Incl. fixing screws (8 pieces) for panel kit and grill frame

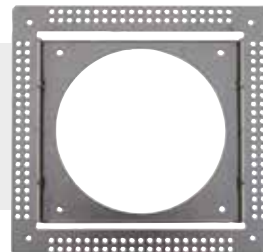

Panel kit Ø125 mm

66031621

Can be combined with grill frame Ø80
For panel thickness 5-30 mm
Incl. fixing screws (8 pieces) for panel kit and grill frame

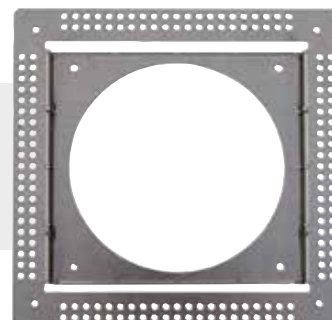

Angular bend Ø80 mm

66031628

Can be combined with grill frame Ø80
For panel thickness 5-30 mm
Incl. fixing screws (8 pieces) for panel kit and grill frame



Angular bend Ø125 mm

66031629

Can be combined with grill frame Ø125
For panel thickness 5-30 mm
Incl. fixing screws (8 pieces) for panel kit and grill frame



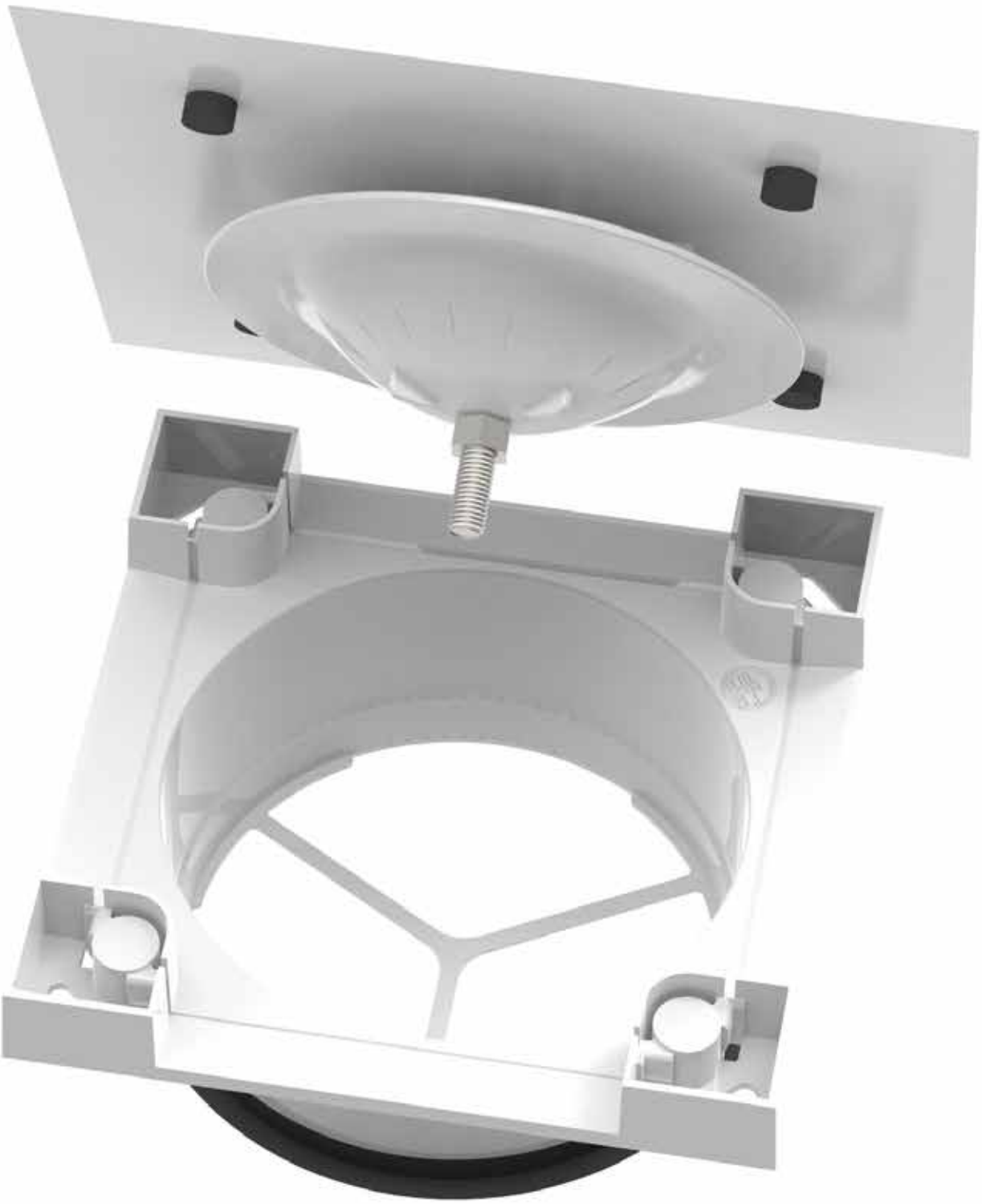

SQAIR VALVE

Technical data sheet see page 87

Ventilate quietly and stylishly

The SQair valve combines both a supply and discharge valve within one single sleek look. The ventilation system is thus integrated into the design of a home in a simple and uniform way. Additional acoustic material has been integrated into the supply valve to ensure whisper-silent ventilation. The deflectors allow you to control the airflow direction in such a way that dirt deposits in corners are prevented.

SQair pulsion valve [Deluxe]

76050400

Aluminium version [RAL9010]
Removable front panel [magnetic fixing]
With acoustic damper
With deflectors

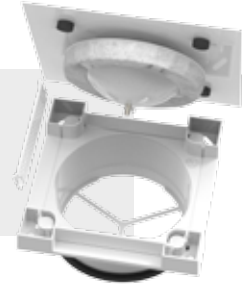

SQair extraction valve [Deluxe]

76050401

Aluminium version [RAL9010]
Removable front plate [magnetic fixing]



SQair pulsion valve [Basic]

76050403

uPVC model [RAL9010]
Removable front panel [clamp into place]
With acoustic damper



SQair extraction valve [Basic]

76050404

uPVC model [RAL9010]
Removable front plate [clamp into place]



Filter SQair pulsion valve

76050406

Compatible with the SQair Pulsion Basic and the SQair Pulsion Deluxe valves



CONNECTION ACCESSORIES

Technical data sheet see page 87

Aludec flexible duct

Aludec Ø82 mm	66014103
Aludec Ø127 mm	66014104
Aludec Ø152 mm	66014107
Aludec Ø162 mm	66014137

1 box = 10m



Isodec insulated flexible duct

Isodec Ø82 mm - 10m	66014100
Isodec Ø127 mm - 10m	66014101
Isodec Ø152 mm - 10m	66014106
Isodec Ø162 mm - 10m	66014138
Isodec Ø180 mm with sleeve 1m	66014129



Acoudec flexible sound damper

0,5 m	
Acoudec Ø82 mm	66014133
Acoudec Ø127 mm	66014134
Acoudec Ø152 mm	66014135
Acoudec Ø162 mm	66014136
Acoudec Ø200 mm	66014140
1 m	
Acoudec Ø82 mm	66014125
Acoudec Ø127 mm	66014126
Acoudec Ø152 mm	66014127
Acoudec Ø162 mm	66014128
Acoudec Ø180 mm with sleeve	66014139
Acoudec Ø200 mm	66014141



Coupling sleeve for 2 flexibles	66014062
For flexibles Ø80 mm	



CONNECTION ACCESSORIES

Galvanised reducer

Reduction Ø125 > Ø80
Reduction Ø150 > Ø125

66014065
66014061



Reduction ring extraction grill

Reduction ring Ø100 > Ø80
Reduction ring Ø125 > Ø80

66014060
66014052



Female socket

Female socket Ø125

66014066



Serrated mounting flange

Serrated mounting flange Ø80
130 mm high

66014001

Serrated mounting flange Ø125
130 mm high

66014005

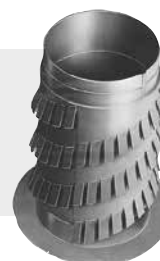

Fixing straps

Fixing strap Ø50- Ø90
Fixing strap Ø60- Ø165

66014110
66014111



PVC tape

PVC tape
50 mm wide
10m per roll
for connecting and sealing rigid ventilation channels

66014115

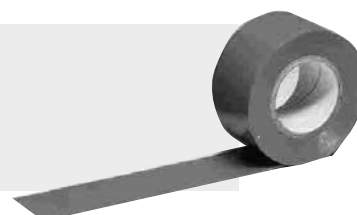

DESIGN ROOF EXHAUSTS

Technical data sheet see page 87

Design roof exhaust

Design roof exhaust

66014096

Ø150/Ø160
Black RAL9005
For tiled roofs



Design roof exhaust

Design roof exhaust

66014097

Ø150/Ø160
Terracotta RAL8004
For tiled roofs



Design roof exhaust

Design roof exhaust

66014095

Ø150/Ø160
Black RAL9005
For slated roofs



Design roof exhaust

Design roof exhaust

66014150

Ø150/Ø160
Black RAL9005
Flex for tiled roofs



Design roof exhaust XL

Design roof exhaust

66014152

Ø180/Ø200
Black RAL9005
Flex for tiled roofs

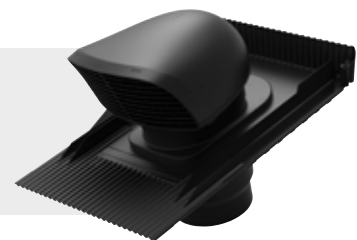

Design roof exhaust XL

Design roof exhaust

66014154

Ø180/Ø200
Terracotta RAL8004
Flex for tiled roofs



Design roof exhaust XL

Design roof exhaust

66014153

Ø180/Ø200
Black RAL9005
For slated roofs



DESIGN ROOF EXHAUSTS & WALL LOUVRES

Technical data sheet see page 87

Design roof exhaust XL

Design roof exhaust **66014151**
 Ø180/Ø200
 Black RAL9005
 Flex for tiled roofs

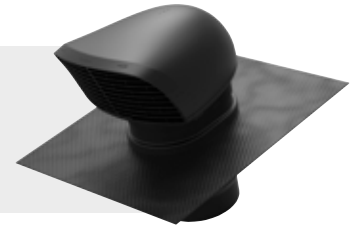

Roof supply All weather

Design roof supply All weather **76050402**
 Ø160
 Black RAL9005

Order accompanying tile separately

Universal roof tile black RAL9005 **66032302**
Universal roof tile terracotta RAL8004 **66032303**
Felt pass through for flat roof **66032304**



Design roof exhaust

Design roof exhaust **66014262**
 Ø125
 Black RAL9005
 For flat roofs



Design roof exhaust XL

Design roof exhaust **66014263**
 Ø160
 Black RAL9005
 For flat roofs



Wall louvre

Wall louvre grey anodised **66114053**
Wall louvre white RAL9010 **66614053**
Wall louvre brown RAL8019 **66714053**
 300x300 mm
 Ø160 - Ø150



Wall louvre

Wall louvre black RAL7021 Ø150 **76050001**
Wall louvre white RAL9016 Ø150 **76050002**
Wall louvre black RAL7021 Ø180 **76050003**
Wall louvre white RAL9016 Ø180 **76050004**
 With drainage profile



EASYDUCT

Technical data sheet see page 87

The Easyduct fixed insulated ducts and accompanying accessories can be used to bridge the distance from the blow off or supply of a ventilation system to the roof/wall passage. Especially in non-insulated rooms, it is recommended to use fixed insulated ducts or insulated cables.

Easyduct insulated EPP tube

76015009

Ø150
1 m
Black
Incl. slave



Easyduct insulated EPP tube

76015022

Ø180
1 m
Black
Incl. slave



Easyduct curve insulated EPP 90°

76015010

Ø150
Black
Incl. slave
Can be cut in 2 curves of 45°



Easyduct curve insulated EPP 90°

76015023

Ø180
Black
Incl. slave
Can be cut in 2 curves of 45°



Easyduct insulated EPP slave

76015012

Ø150
Black



Easyduct insulated EPP slave

76015024

Ø180
Black



CO₂ MONITOR

Technical data sheet see page 87

IAQ (Indoor Air Quality) is the benchmark for indoor air quality, because a comfortable indoor environment keeps people fresh, work efficient and healthy. The CO₂ concentration is an important indicator for good indoor air quality. The Renson CO₂ monitor can be a useful tool for this.

CO₂ monitor

60017485



Battery CO₂ monitor

60017585





TECHNICAL DATA SHEET

Looking for technical specifications? In this section you will find all the features and details of the ventilation systems and their components.

Cbase®	p. 88
Cube®	p. 89
Extravent® EcoModus Compact	p. 90
Healthbox® 3.0	p. 92
Endura® Delta 330	p. 100
Endura® Delta 380	p. 104
Endura® Delta 450	p. 108
Comparison Endura® Delta 330-380-450	p. 112
Endura®	p. 114
Healthconnector®	p. 118
Design extraction louvres	p. 126
SQair valve	p. 128
Flexible ducts	p. 130
Easyduct	p. 137
Easyflex®	p. 150
Design roof exhaust	p. 179
Wall louvres	p. 187
CO ₂ -monitor	p. 190

TECHNICAL DATA SHEET:

Cbase

PRODUCT SPECIFICATIONS

- 0-10V silent, vibration-free EC motor
- Variable airflow and pressure level according to the chosen voltage [0-10V], maximum airflow of 262 m³/h at 100Pa
- Continuous adjustment
- 3 stage switch [sold separatly]
- Possibility to connect up to 6 wet rooms thanks to 6 extraction inlets on the ventilation unit [branching ducts is possible]
- Standardly 4 inlet points are equipped with adjustable air canal joints Ø125 en Ø80 / 2 inlets are closed off with a stop
- Extraction Ø125 mm [with adaptor to Ø150 mm]
- Recyclable plastic housing [polypropylene]
- Compact: easy to integrate in a technical room, attic or suspended ceiling
- Mounted horizontally or vertically by means of 4 screws
- Easy maintenance of the ventilation unit thanks to the removable cover
- Whisper quiet motor



45 dB(A) 262 m³/h

TECHNICAL SPECIFICATIONS

- Dimensions: 320 x 320 x 180 mm [LxWxH]
- Weight: 3,370 Kg
- Voltage: 1 x 230V/50Hz
- Average power consumption: depends on the chosen ventilation stage
- Maximum power consumption: 28 W

FAN CURVES

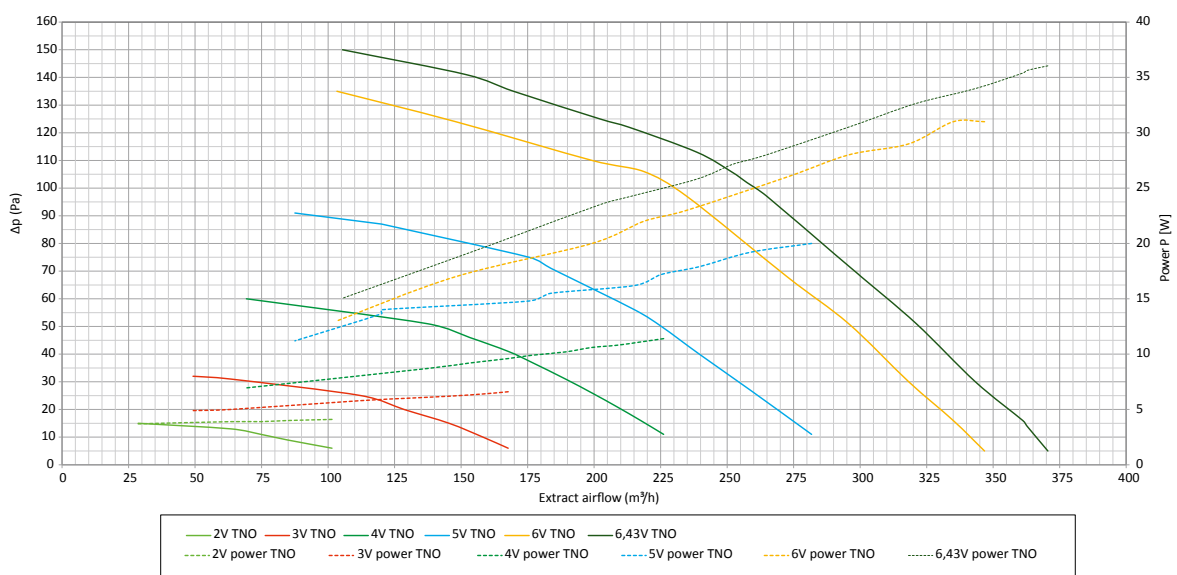

TECHNICAL DATA SHEET:

Cube®

PRODUCT CHARACTERISTICS

- EC DC motor: total flow rate, 350 m³/h at 190 Pa maximum pressure
 - Thermally protected
 - 0-10 V controlled
- Demand-controlled ventilation with settings based on:
 - Relative humidity [central humidity sensor in the unit]
 - Presence [wired presence sensors in toilet / bathroom + toilet]
 - NIKO® base with claw fixing
 - Cover plate not included
 - Central core compatible with BTicino
 - Min.: 2 x 0.34 mm² / Max.: 2 x 0.8 mm² [30 m max. length]
 - No external power supply required
 - CO₂ in the kitchen [sensor integrated in the control]
 - Air quality indication on the control [green - orange - red]
 - 230 V power supply
- Control via TouchDisplay
 - RF communication
 - 230 V power supply
- Capability for connecting 6 wet rooms thanks to 6 extraction points
- 6 extraction points as standard, equipped with 125 and 80 mm diameter adapter fittings
- 125 mm diameter exhaust point [adapter to 150 mm dia.]
- Recyclable plastic housing [polypropylene]
- Compact format: easy to incorporate in technical room, attic or false ceiling/wall
- Horizontal or vertical fitting using 4 screws
- Removable cover plate and motor plate make for simple maintenance of the fan unit
- Whisper-quiet motor



B 48 dB(A) 350 m³/h

TECHNICAL SPECIFICATIONS

- Dimensions: 320 x 320 x 180 mm [L x W x H]
- Weight: 3.350 Kg
- Supply voltage: 1 x 230 V / 50 Hz
- Maximum consumption: 86 W

FAN CURVES

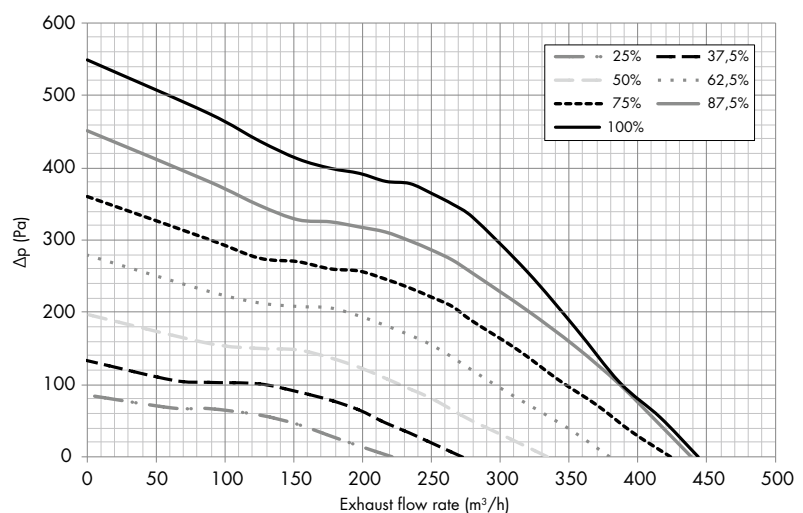

TECHNICAL DATA SHEET:

Xtravent Ecomodus Compact

PRODUCT SPECIFICATIONS

- EC vibration-free direct current motor: total airflow of 350m³/h at max pressure of 200Pa
- Possible to connect up to 6 rooms thanks to 6 extraction points on the unit
- Standardly all 6 extraction points equipped with adaptors Ø125 and Ø80
- Exhaust Ø125mm [adaptor to Ø150mm]
- Recyclable plastic housing [polypropylene]
- Compact size: easy to install in a technical room, attic or behind a false ceiling/wall
- Horizontal or vertical installation by means of 4 screws
- Easy maintenance of the fan thanks to removable cover
- Whisper quiet motor
- Controlled via 3 stage switch
- Extraction grill:
 - Rectangular white PVC grill [RAL 9010] with removable front panel for maintenance
 - Connection diameter 80mm
 - Power supply: 9V battery [not included] or power board 12 VAC [optional]
 - Dimensions extraction grilles PH75 , PT25 , H50 : 151 x 159 x 43mm [LxWxH]
 - Easy maintenance with removable cover



B 47 dB(A) 350 m³/h

PT25: Extraction toilet with presence detector and timer 20 '

H50: Extraction laundry room fluid control with humidity sensor

PH75: Extraction bathroom or kitchen with presence detector and humidity sensor

TECHNICAL SPECIFICATIONS

- Dimensions: 320 x 320 x 180mm [LxWxH]
- Weight : 3.455 Kg
- Voltage: 1 x 230V/50Hz
- Average power consumption: 27W
- Max power consumption: 54W

FAN CURVES

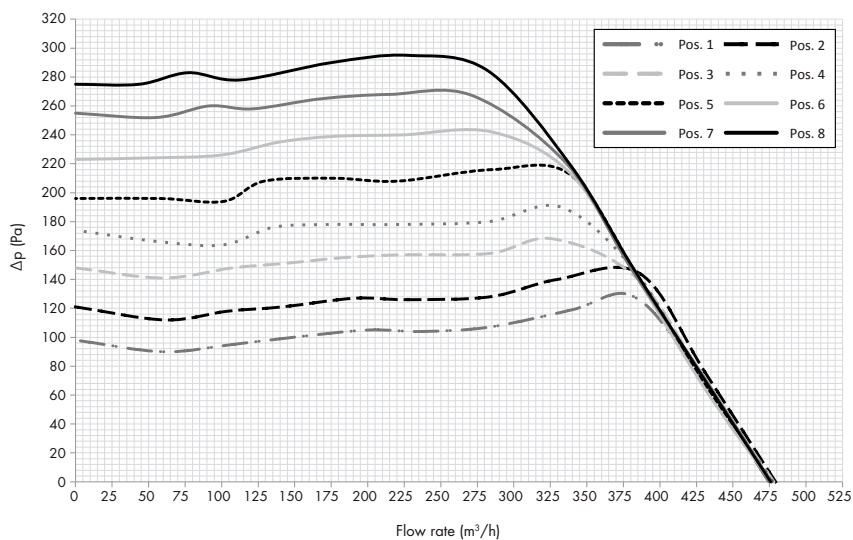

TECHNICAL DATA SHEET:

Healthbox® 3.0

VENTILATION UNIT FOR DEMAND-CONTROLLED MECHANICAL EXTRACTION

Healthbox 3.0 is utilised as a central ventilation system which controls the extraction flow rate from each room. Healthbox 3.0 is an integral component of the energy-saving C* ventilation system.

RANGE OF APPLICATION

- Incorporating demand-controlled ventilation in a dwelling/apartment/etc.
- Suitable for use in new buildings and renovation projects.
- A suitable system to achieve a worthwhile gain in E-level [Flemish energy performance requirement], thus bringing the dwelling up to the legally required E-level or better.
- Direct control of air quality can be achieved in all rooms in the dwelling by extracting stale air from dry rooms as well. This will achieve the maximum E-level gain in the system.
- Optimum operation of the C* ventilation system can only be guaranteed if the following components are in place and matched to one another:
 - Fresh air supply via self-regulating Renson window ventilators [class P3 or P4]
 - Air throughput
 - Extraction of stale air via the Healthbox 3.0



Basic form

MAIN FEATURES

Healthbox 3.0 consists of a fan unit with control valves to be connected externally.

- **Demand-driven ventilation**
 - Guaranteed good air quality plus heat saving
 - Built-in sensors measure indoor air quality 24 hours a day in the extracted air flow
 - Extraction flow rate controlled on the basis of measured indoor air quality
- **Central fan**
 - Low-noise and energy-efficient EC motor
- **Up to 11 rooms can be connected**
- **Ease of installation**
 - The installer app guides the installer through the start-up process:
 - Automatic calibration appreciably reduces installation time
 - Configurable control valves: extraction flow rate can be set individually for each room
 - Smart / compact air duct management in small spaces thanks to the valve collectors
 - Digital generation of measurement report
- **SmartConnect**
 - Healthbox 3.0 communicates with the user app, installer app and other devices/appliances in a smart home
- **Design extraction points**
 - Design extraction points [recessed or surface-mounted] can be fitted without control valves in the rooms

TECHNICAL DATA SHEET:

Healthbox® 3.0

ITEM CODE

Item code	Designation	Main components
66060100	Healthbox 3.0 kit	<ul style="list-style-type: none"> Healthbox 3.0 fan unit Control valves: kitchen - bathroom - toilet
66060101	Healthbox 3.0 SmartZone kit	<ul style="list-style-type: none"> Healthbox 3.0 fan unit Control valves: kitchen - bathroom - toilet - two bedrooms

SYSTEM SPECIFICATIONS

Type of ventilation	Mechanical demand-controlled extraction
[Max.] ventilation flow rate	475 m ³ /h [at 135 Pa] 430 m ³ /h [at 200 Pa] <i>Fan specifications: see technical drawings</i>
Supply voltage	230 VAC ±10% [50 Hz, 60 Hz] <i>Mains plug included</i>
Fan unit rated power - At max. flow rate of 150 m ³ /h: - At max. flow rate of 225 m ³ /h: - At max. flow rate of 325 m ³ /h: - At max. flow rate of 400 m ³ /h: - At max. flow rate of 475 m ³ /h:	28 watts 35 watts 53 watts 80 watts 85 watts <i>See graphs</i>
Dimensions: - Fan unit without control valves - Fan unit with control valves	390 x 443 x 200 mm [LxWxH] 567 x 567 x 200 mm [LxWxH] <i>See technical drawings</i>
Connection dia. for intake duct	Choice via adaptor: 80 and/or 125 mm dia.
Connection dia. for extraction duct	Choice via adaptor: 125 or 150 mm dia. <i>[160 mm dia. via optional ring]</i>
Fan	Extremely quiet & energy-efficient EC motor with 180 mm dia. impeller. Active variable pressure control: the lowest possible pressure level is set in each case consistent with the required extraction flow rates.
Maximum fan operating pressure	350 Pa - Recommended operating pressure at design flow rate: ≤ 200 Pa - Target value for a very good operating pressure at design flow rate (cf. TV No. 258): ≤ 100 Pa
Calibration readout	Via user app, installer app & Renson web portal
Automatic calibration of ventilation flow rates <i>[patented]</i>	Takes place in 2 successive stages: - Stage 1: pressure drop readings taken automatically in all air ducts - Stage 2: valve positions for air distribution calculated automatically
Maximum number of connection points for extraction: - Basic form - Using valve collectors	7 11 <i>[subject to a few limiting conditions]</i>
Valve collector	1 or 2 valve collectors to be connected to the fan unit, with 1 to 3 control valves to be connected to each valve collector. The valve collector can also be connected remotely from the fan unit. Electrical connection (UTP cable Cat 5e, wire gauge 24AWG, 30 metres max.).
Connections	- 1x LAN connection - 2x USB connection <i>[USB dongle for Wi-Fi connection included]</i> - Inputs: 3x DIGITAL, 1x ANALOGUE [0-10 V] - Outputs: 2x DIGITAL, 1x ANALOGUE [0-10 V]
Breeze function	Temporary nominal ventilation [= demand control deactivated] at times when there is a given cooling need [= optimum shading factors]

TECHNICAL DATA SHEET:

Healthbox® 3.0

DEMAND-CONTROLLED VENTILATION CONTROL

The control valves provide individual demand control for each connected room. The control is applied consistent with the chosen country setting.

Air quality detection (CO ₂ or humidity and/or VOC)	Via electronic sensors in control valves. The sensors measure indoor air quality 24 hours a day in the exhaust air flow for each room.
Automatic control of ventilation extraction flow rate for each room	The stepper motor positions the internal valve damper based on measured sensor values. The extraction flow rate is controlled in this way consistent with air quality.
Ventilation extraction flow rate control algorithm (BE)	<ul style="list-style-type: none"> - CO₂ detection: proportional to 100% of nominal flow rate - VOC detection: dynamic, 10% or 100% of nominal flow rate - Humidity detection: dynamic, 10% or 100% of nominal flow rate

CONTROL VALVES

There are a number of predefined control valves. The desired nominal flow rate for each control valve can be set via the installer app. The make-up of the control valves is virtually identical, the only differentiation being:

- Plug-in printed circuit board with sensors
- Sticker on the stepper motor that shows the room to be connected



Predefined control valves				
Sticker on stepper motor	Room to be ventilated (BE)	CO ₂ detection	Humidity detection	VOC detection
	Bathroom with toilet <i>Wellness, garage, basement, etc.</i>	-	✓	✓
	Laundry room <i>Shower room, bathroom without toilet, etc.</i>	-	✓	-
	Toilet <i>Storeroom, technical rooms, workshop, walk-in wardrobe, hall/corridor, etc.</i>	-	-	✓
	Kitchen (open/closed)	✓	-	-
	Bedroom <i>Living room, office, study, hobby room, waiting room, leisure area, dining room, etc.</i>	✓	-	-

TECHNICAL DATA SHEET:

Healthbox® 3.0

OTHER FEATURES

Automatic fault indication	<ul style="list-style-type: none"> - Via user app - Via installer app: fault indication reported during start-up phase - Via Renson web portal [both user and installer]
Automatic software updates	If Healthbox 3.0 is connected to the internet
User & installer app	<ul style="list-style-type: none"> Can be downloaded free of charge from Play Store [Android] and App Store [Apple] - User app: My Healthy Ventilation - Installer app: Renson SmartConnect Ventilation
Integration into smart home & home automation	<ul style="list-style-type: none"> Communication can take place if Healthbox 3.0 is connected to a home network [Wi-Fi or cable]: - Home network: communication via <i>local</i> REST API - Internet: communication via <i>server</i> REST API
Access to Renson web portal	<ul style="list-style-type: none"> - User: if Healthbox 3.0 is connected to the internet, via account - Installer: via account
Fire protection [= release pressure in system with valves shut]	✓
EPB	Shading factors in accordance with table 2 of the set table [see Healthbox 3.0 specification sheet]

CONTROL

2 options:

- 'My Healthy Ventilation' app:
 - Readout of air quality in dwelling down to room level
 - Facility for personalisation and [temporary] manually changing ventilation extraction flow rate down to room level
- Zero potential switch [3 positions] for manually changing ventilation extraction flow rate [via DIGITAL input]

HEALTHBOX 3.0 INSTALLATION

Installation

Room	Indoor installation, preferably in insulated room
Mounting options	<ul style="list-style-type: none"> - Can be mounted in any attitude: upright, flat [above/below], angled - Four mounting options: wall mounted, ceiling mounted, floor mounted, cord mounted [suspended, cover on top]
Exhaust direction	By using valve collectors, the exhaust direction can always be fitted in any desired direction => reduced pressure drop

The fan unit requires a minimum of 2 control valves to be connected to it.

Start-up

Start-up via installer app	<ul style="list-style-type: none"> The app guides the installer through the start-up, enabling a reliable high-quality system to be installed rapidly: - Display of control valve configuration - Automatic calibration start-up, with facility for adjusting nominal flow rate + indication of remaining time - Overview of completed installation + digital generation of measurement report
----------------------------	------------------------------------------------------------------------------------------------------------------------------------------------------------------------------------------------------------------------------------------------------------------------------------------------------------------------------------------------------------------------------------------------------------------------------------------

TECHNICAL DATA SHEET:

Healthbox® 3.0

Renson SmartConnect web portal

The Renson web portal guides the installer throughout project management and monitoring, from start-up to completion and on to after-sales service [near future]. The web portal comprises all project essentials:

- Project creation
- Project address details, installer on duty, Healthbox 3.0 status, installation parameters, etc.
- Sending measurement report digitally
- Data readout for after-sales service [near future]

This will bring about digitisation and administrative simplification of paperwork.

RENSON OPTIONS

Extraction vents	Design extraction points
Easyflex air ducts	Air transport ducts, airtightness class D
Acoudec	Air hose with high acoustic insulation properties
Roof exhaust / wall louvre	Suitable feed-through fittings with low pressure drop
Triple flow	Combined system for common ventilation extraction and flue gas supply and extraction
Fire kit	For compartmentalising in order to reduce fire spread risk

TECHNICAL DATA SHEET:

Healthbox® 3.0

TECHNICAL DRAWINGS

- Fan unit without control valves

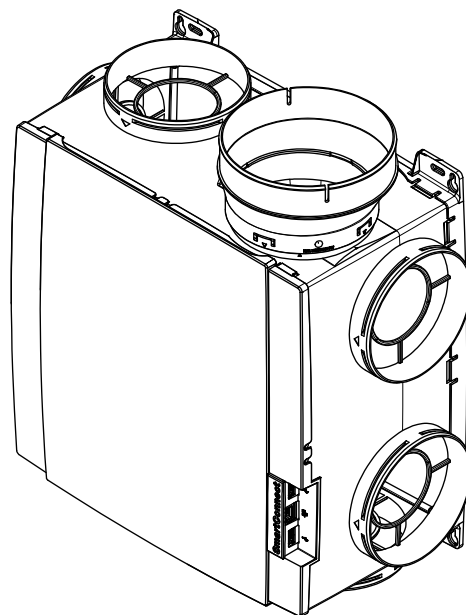
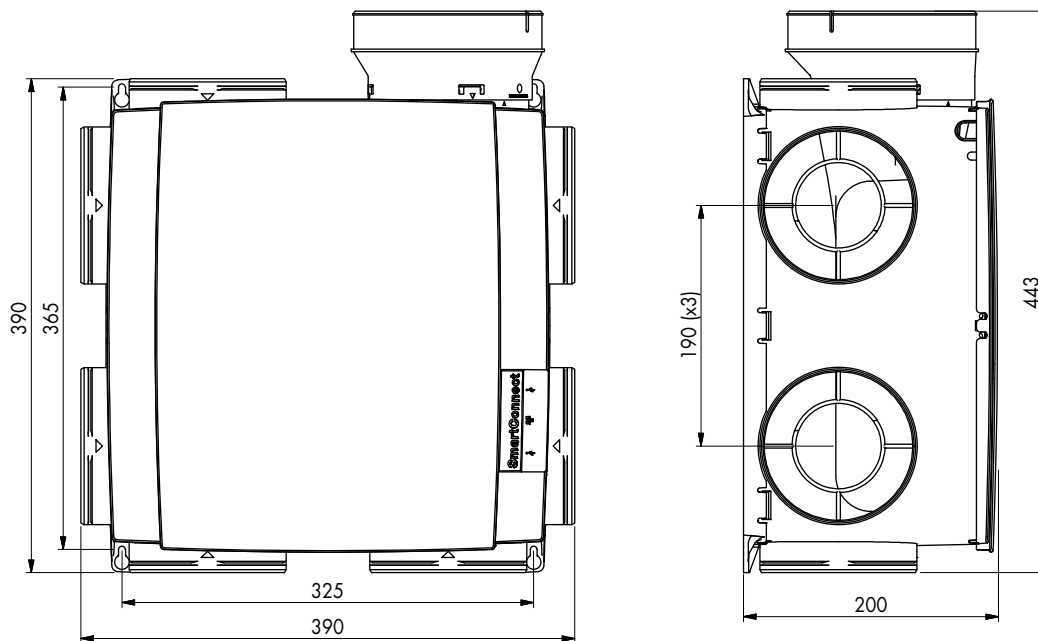

TECHNICAL DATA SHEET:

Healthbox® 3.0

- Fan unit with control valves

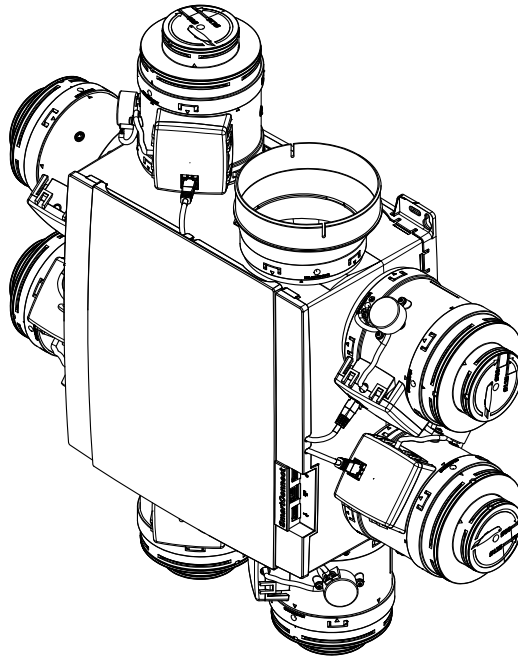
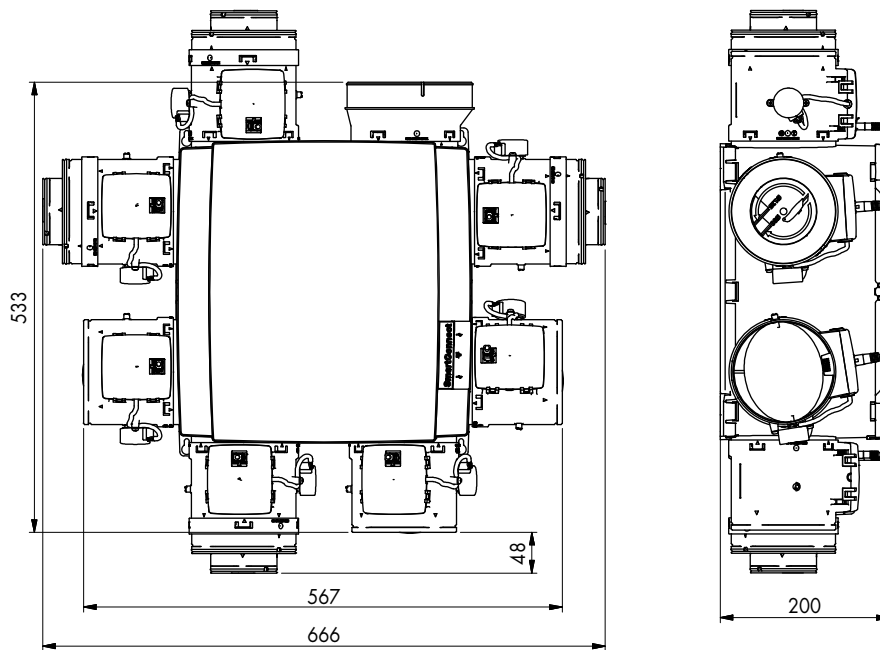

TECHNICAL DATA SHEET:

Healthbox® 3.0

- Healthbox 3.0 with 11 control valves

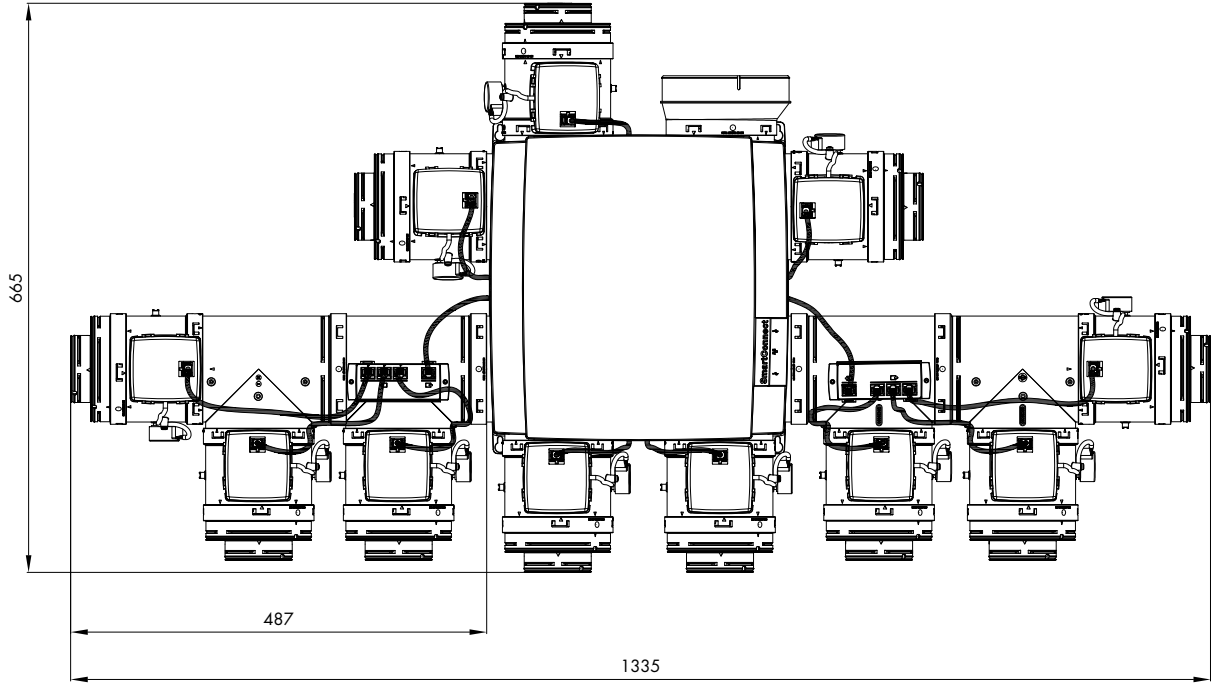

- Valve collector

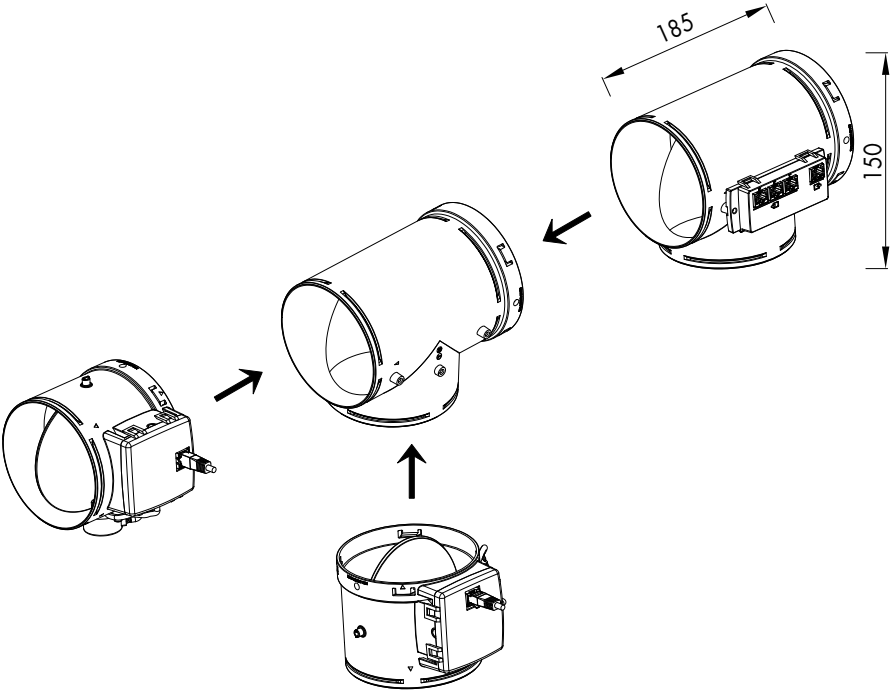

TECHNICAL DATA SHEET:

Healthbox® 3.0

GRAPHS

- Fan unit characteristics

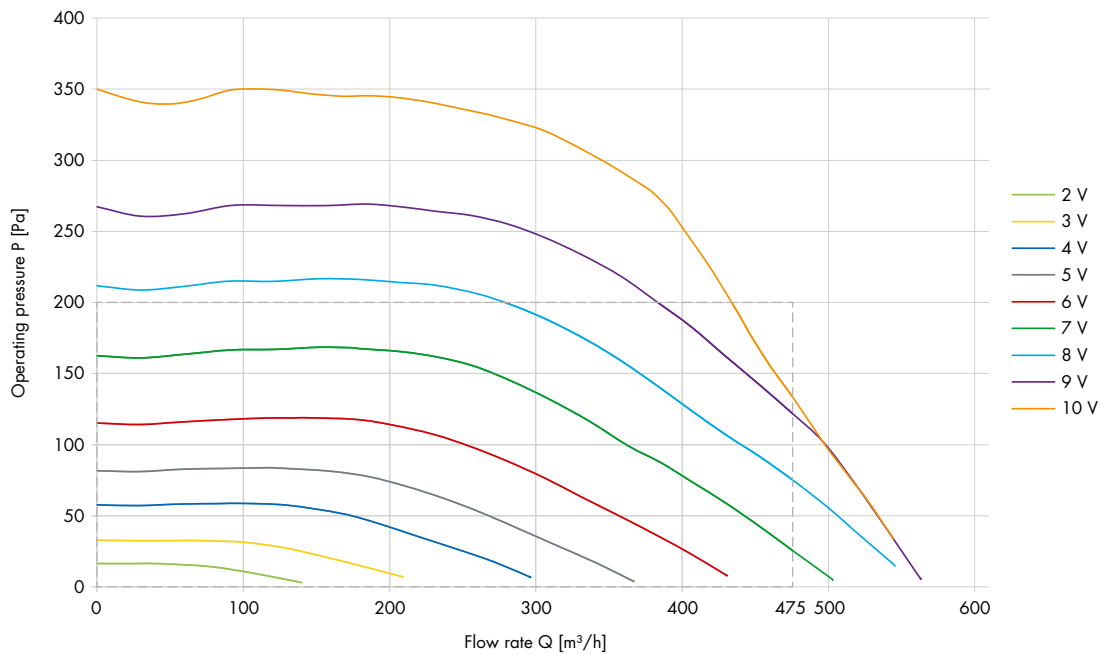

- Fan power curves

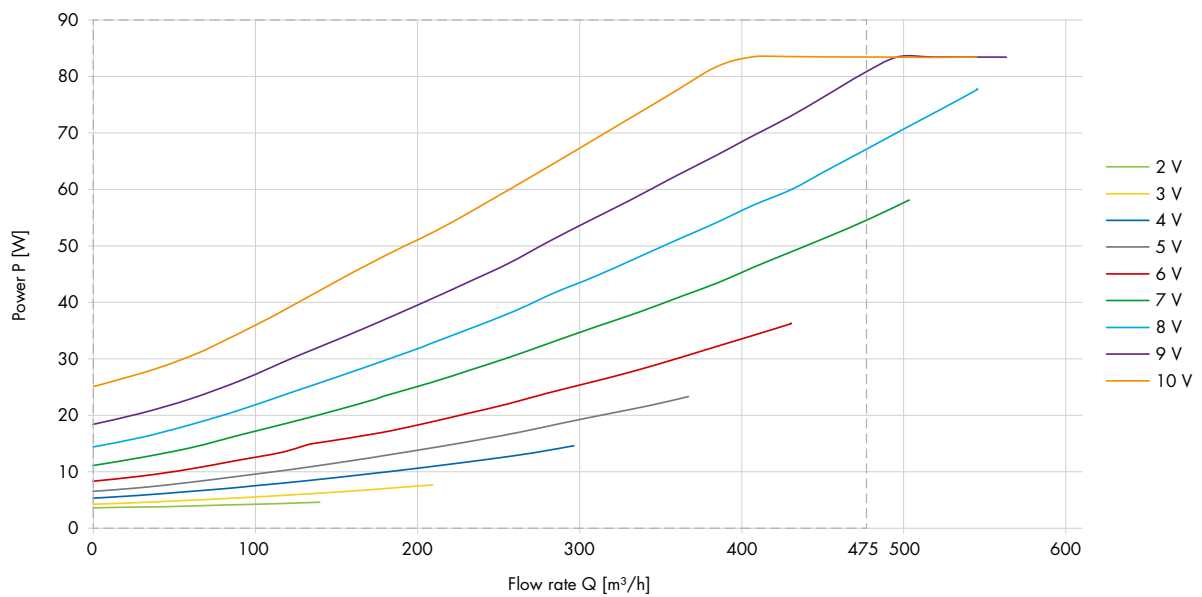

TECHNICAL DATA SHEET:

Endura® Delta 330

AREA OF APPLICATION

- Can be used in new constructions
- Mechanically supplied fresh air
- Mechanically drainage of used air
- Demand-driven ventilation thanks to integrated air quality sensors
- High-efficiency heat exchanger for energy saving



Endura Delta 330 T4

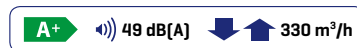

Endura Delta 330 T2/B2

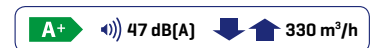

PRODUCT CHARACTERISTICS

EPB product data

- Max. capacity: 330 m³/h at 150 Pa
- Integrated plastic counter flow **heat exchanger**
- Maximum power consumption: 2 x 85 W

Ventilation system

- **Ventilators**
 - 2 EC motors
 - Supply voltage: 1 x 230V / 50Hz
 - Ventilators with forward-curved blades
 - Constant flow control: airflow remains constant
- Dimensions: H 862 x W 745 x D 520 mm
- Weight: 41 kg
- Available with 4 upper connections [T4] or 2 upper and 2 lower connections [T2/B2]
- Standard **left-hand model**, possible to convert to **right-hand model**
- Automatic **full bypass**
 - Modular control
 - Closing of the heat exchanger during warm weather
- 150/180 mm diameter connections **in expanded polypropylene**
 - Direct join to the unit:
 - EPP ducts: outer diameter 180 mm, inner diameter 150 mm
 - EPP ducts: with connecting sleeve: outer diameter 200 mm, inner diameter 180 mm
 - Other ducts: 180 mm diameter can be connected directly onto the ventilation system

- Integrated condensation drain Ø32 mm
- Extremely airtight appliance
- **2 x coarse [G4] cartridge filters** (PM1 [F7] optional for supply)
 - Maintenance-friendly
 - Large filter surface area
- **Ethernet connection [RJ45 connector]**
 - Possibility to control unit via tablet /smartphone via local network
- **External input/output contacts**
 - **Open input contact [digital 0-24 V]**
 - Supply and extract disabling option – e.g. emergency OFF to switch off supply flow rate
 - Supply switch-off
 - Drainage switch-off
 - Activation of fireplace function via external contact
 - **Open output contact [digital 0-24 V]**
 - Error message
 - Filter message
 - **0-10V analogue input**
 - **0-10V analogue output**

TECHNICAL DATA SHEET:

Endura® Delta 330

FUNCTIONS

- Operation
 - According to automatic mode [program]
 - Manual control
 - Timers
 - Via integrated air quality sensors [RH, CO₂ & VOC]
 - Via optional, external air quality sensors
- **Demand-driven ventilation** thanks to integrated air quality sensors
 - Relative humidity
 - VOC [volatile organic compounds]
 - CO₂
 - Ventilation levels adapted in accordance with measured air quality
- Automatic **frost protection**
 - Temporary imbalance and flow restriction to prevent freezing of the heat exchanger
- Extra frost protection option through installation of **pre-heating element**
 - Electrical pre-heating element
 - Modular power
 - Max. power: 1000 W
- **Breeze function**
 - Breeze function for optimum cooling in summer [summer bypass with adjustable ventilation level]
 - Automatic and manual bypass activation
 - 4-seasons automatically controlled indoor temperature
- **Fireplace function**
 - Activated via external pulse switch
 - Temporary imbalance on supply side [overpressure] to aid ignition process
- Holiday mode
 - Input of start and end dates during prolonged absence
 - System ventilates at maximum energy efficiency
- Filter message
 - Via smartphone
 - On external control unit [optional]
 - Timer-controlled

CONTROL

Standard control via Endura® Delta App (iOS, Android, Windows) on smartphone and tablet

Options

- **Master air quality sensor [76050330]**
 - Display of air quality and ventilation intensity
 - Integrated air quality sensor
 - Display of active program
 - Timer programming possible
 - Power via motor unit [connect directly to the motor unit]
- **Slave air quality sensor [76050331]**
 - Always in combination with Master
 - Wireless communication with Master
 - Power voltage 230V / 50Hz
 - Integrated air quality sensor
 - Same information as on the Master available
- **4-position switch** [on request]
 - Limited functionality



Endura® Delta app



TouchDisplay

TECHNICAL DATA SHEET:

Endura® Delta 330

MODELS

DESIGNATION	ARTICLE NUMBER
Endura Delta 330 T4	76050800
Endura Delta 330 T4 PH	76050801
Endura Delta 330 T2/B2	76050802
Endura Delta 330 T2/B2 PH	76050803

Endura Delta 330 Left [standard]

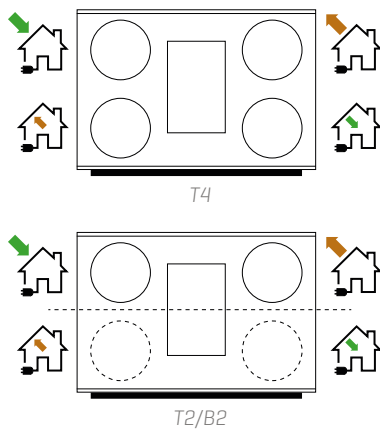

Endura Delta 330 Right [only possible after conversion]

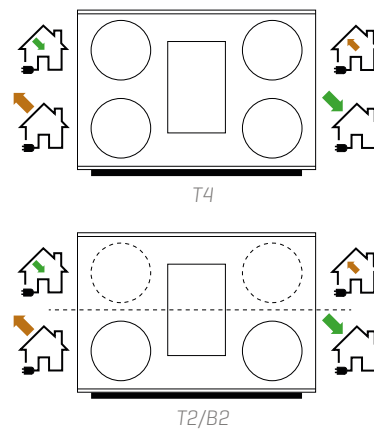

PRESSURE CURVES

Fan curves for the Endura Delta 330
pressure based on flow rate

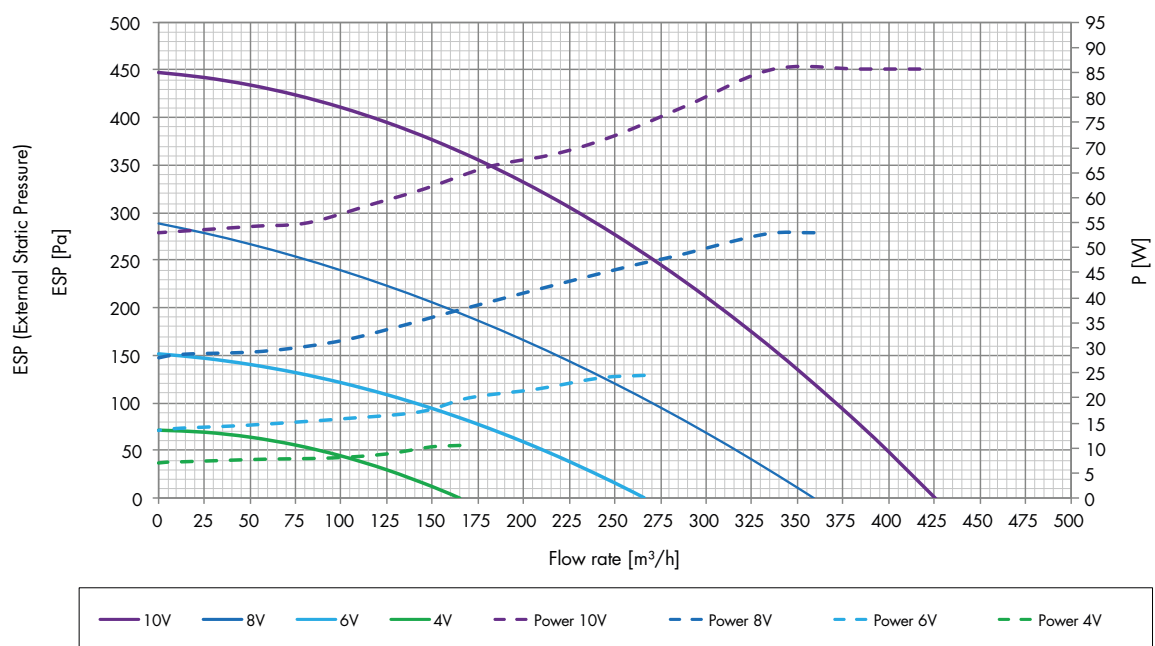

TECHNICAL DATA SHEET:

Endura® Delta 330

TECHNICAL DRAWINGS

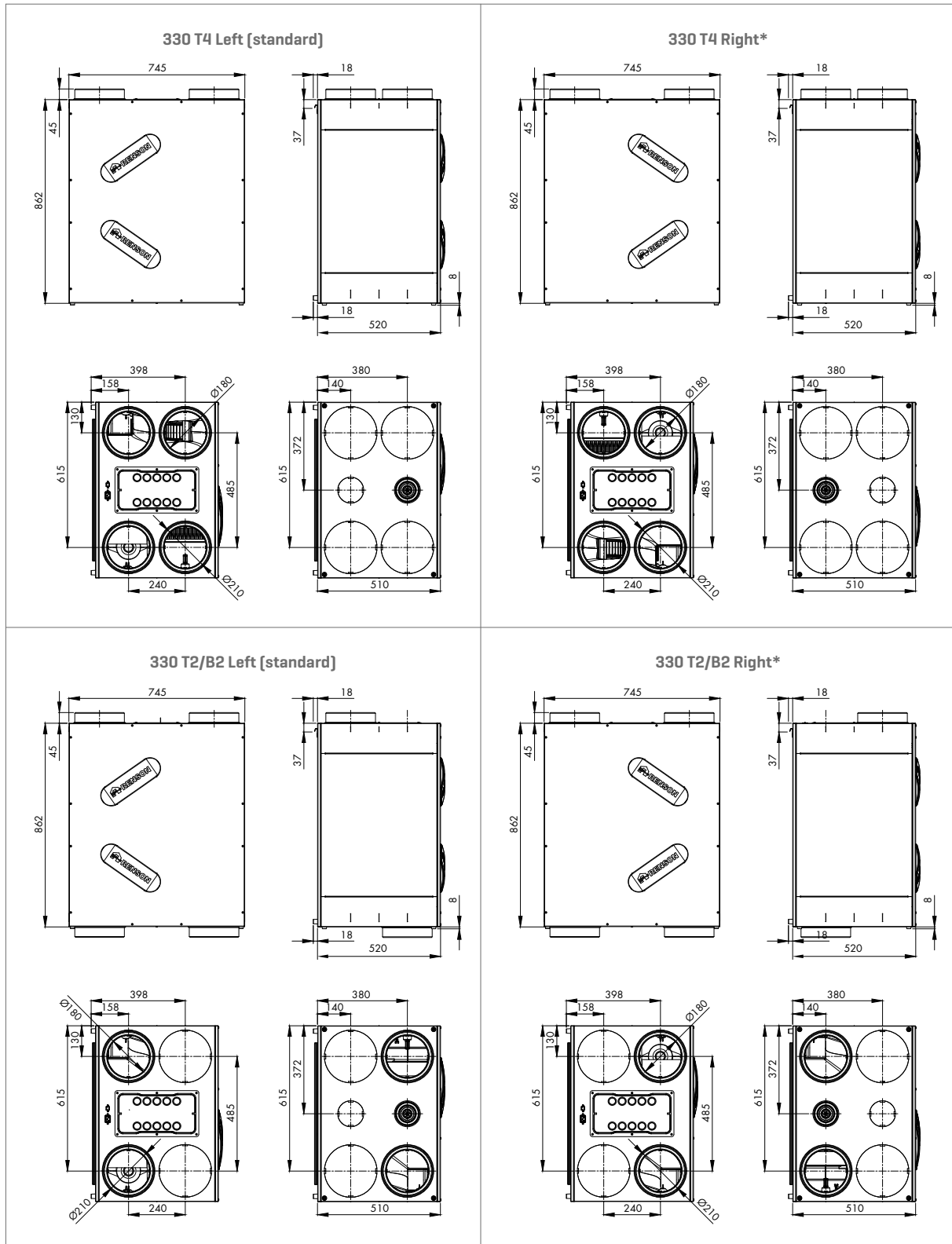

* Only possible after conversion.

TECHNICAL DATA SHEET:

Endura® Delta 380

AREA OF APPLICATION

- Can be used in new constructions
- Mechanically supplied fresh air
- Mechanically drainage of used air
- Demand-driven ventilation thanks to integrated air quality sensors
- High-efficiency heat exchanger for energy saving



Endura Delta 380 T4

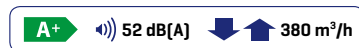

Endura Delta 380 T2/B2

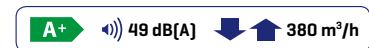

PRODUCT CHARACTERISTICS

EPB product data

- Max. capacity: 380 m³/h at 150 Pa
- Integrated plastic counter flow **heat exchanger**
- Maximum power consumption: 2 x 83 W

Ventilation system

- **Ventilators**
 - 2 EC motors
 - Supply voltage: 1 x 230V / 50Hz
 - Ventilators with backward-curved blades
 - Constant flow control: airflow remains constant
- Dimensions: H 862 x W 745 x D 520 mm
- Weight: 46 kg
- Available with 4 upper connections [T4] or 2 upper and 2 lower connections [T2/B2]
- Standard **left-hand model**, possible to convert to **right-hand model**
- Automatic **full bypass**
 - Modular control
 - Closing of the heat exchanger during warm weather
- 150/180 mm diameter connections **in expanded polypropylene**
 - Direct join to the unit:
 - EPP ducts: outer diameter 180 mm, inner diameter 150 mm
 - EPP ducts: with connecting sleeve: outer diameter 200 mm, inner diameter 180 mm
 - Other ducts: 180 mm diameter can be connected directly onto the ventilation system

- Integrated condensation drain Ø32 mm
- Extremely airtight appliance
- **2 x coarse [G4] cartridge filters** (PM1 [F7] optional for supply)
 - Maintenance-friendly
 - Large filter surface area
- **Integrated TouchDisplay** in front panel
 - Touchscreen
 - Possibility to configure and control ventilation unit
 - Error feedback
 - Filter message
 - Visualization of current ventilation conditions
- **Ethernet connection [RJ45 connector]**
 - Possibility to control unit via tablet /smartphone via local network
- **External input/output contacts**
 - **Open input contact [digital 0-24 V]**
 - Supply and extract disabling option – e.g. emergency OFF to switch off supply flow rate
 - Supply switch-off
 - Drainage switch-off
 - Activation of fireplace function via external contact
 - **Open output contact [digital 0-24 V]**
 - Error message
 - Filter message
 - **0-10V analogue input**
 - **0-10V analogue output**

TECHNICAL DATA SHEET:

Endura® Delta 380

FUNCTIONS

- Operation
 - According to automatic mode [program]
 - Manual control
 - Timers
 - Via integrated air quality sensors [RH, CO₂ & VOC]
 - Via optional, external air quality sensors
- **Demand-driven ventilation** thanks to integrated air quality sensors
 - Relative humidity
 - VOC [volatile organic compounds]
 - CO₂
 - Ventilation levels adapted in accordance with measured air quality
- Automatic **frost protection**
 - Temporary imbalance and flow restriction to prevent freezing of the heat exchanger
- Extra frost protection option through installation of **pre-heating element**
 - Electrical pre-heating element
 - Modular power
 - Max. power: 1000 W
- **Breeze function**
 - Breeze function for optimum cooling in summer [summer bypass with adjustable ventilation level]
 - Automatic and manual bypass activation
 - 4-seasons automatically controlled indoor temperature
- **Fireplace function**
 - Activated via external pulse switch
 - Temporary imbalance on supply side [overpressure] to aid ignition process
- Holiday mode
 - Input of start and end dates during prolonged absence
 - System ventilates at maximum energy efficiency
- Filter message
 - Via smartphone
 - On integrated TouchDisplay
 - On external control unit [optional]
 - Timer-controlled

CONTROL

- **With Endura Delta app**
 - iOS, Android and Windows
 - Smartphone and tablet
- **TouchDisplay on unit**
 - Power and communication with motor unit via RS232
 - Possibility to program the motor unit with the TouchDisplay

Options

- **Master air quality sensor [76050330]**
 - Display of air quality and ventilation intensity
 - Integrated air quality sensor
 - Display of active program
 - Timer programming possible
 - Power via motor unit [connect directly to the motor unit]
- **Slave air quality sensor [76050331]**
 - Always in combination with Master
 - Wireless communication with Master
 - Power voltage 230V / 50Hz
 - Integrated air quality sensor
 - Same information as on the Master available
- **4-position switch [on request]**
 - Limited functionality



Endura® Delta app



TouchDisplay

TECHNICAL DATA SHEET:

Endura® Delta 380

MODELS

DESIGNATION	ARTICLE NUMBER
Endura Delta 380 T4	76050804
Endura Delta 380 T4 PH	76050805
Endura Delta 380 T2/B2	76050806
Endura Delta 380 T2/B2 PH	76050807

Endura Delta 380 Left [standard]

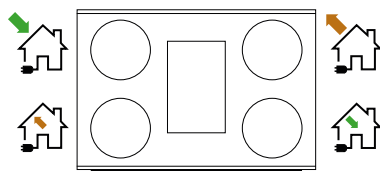

T4

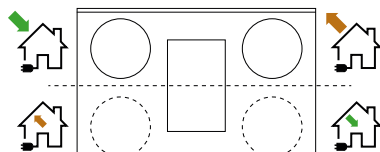

T2/B2

Endura Delta 380 Right [only possible after conversion]

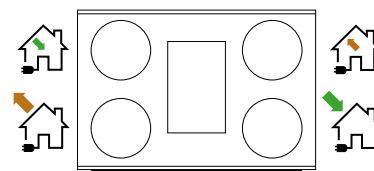

T4

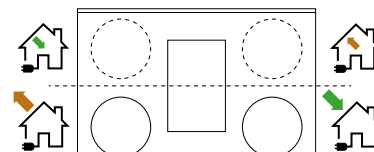

T2/B2

PRESSURE CURVES

Fan curves for the Endura Delta 380
pressure based on flow rate

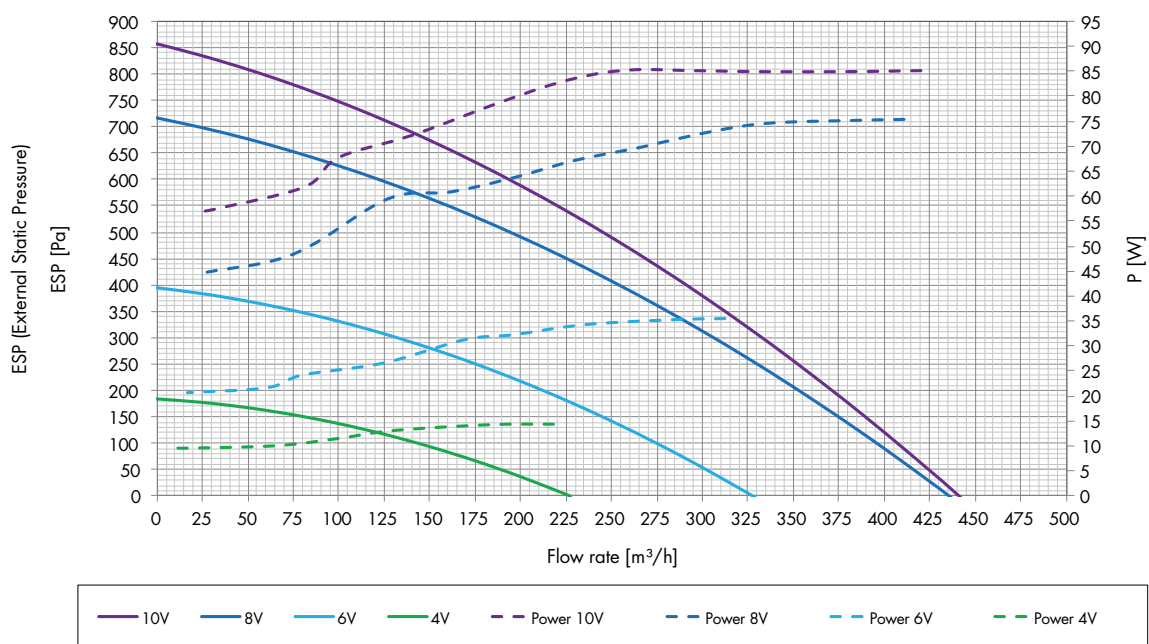

TECHNICAL DATA SHEET:

Endura® Delta 380

TECHNICAL DRAWINGS

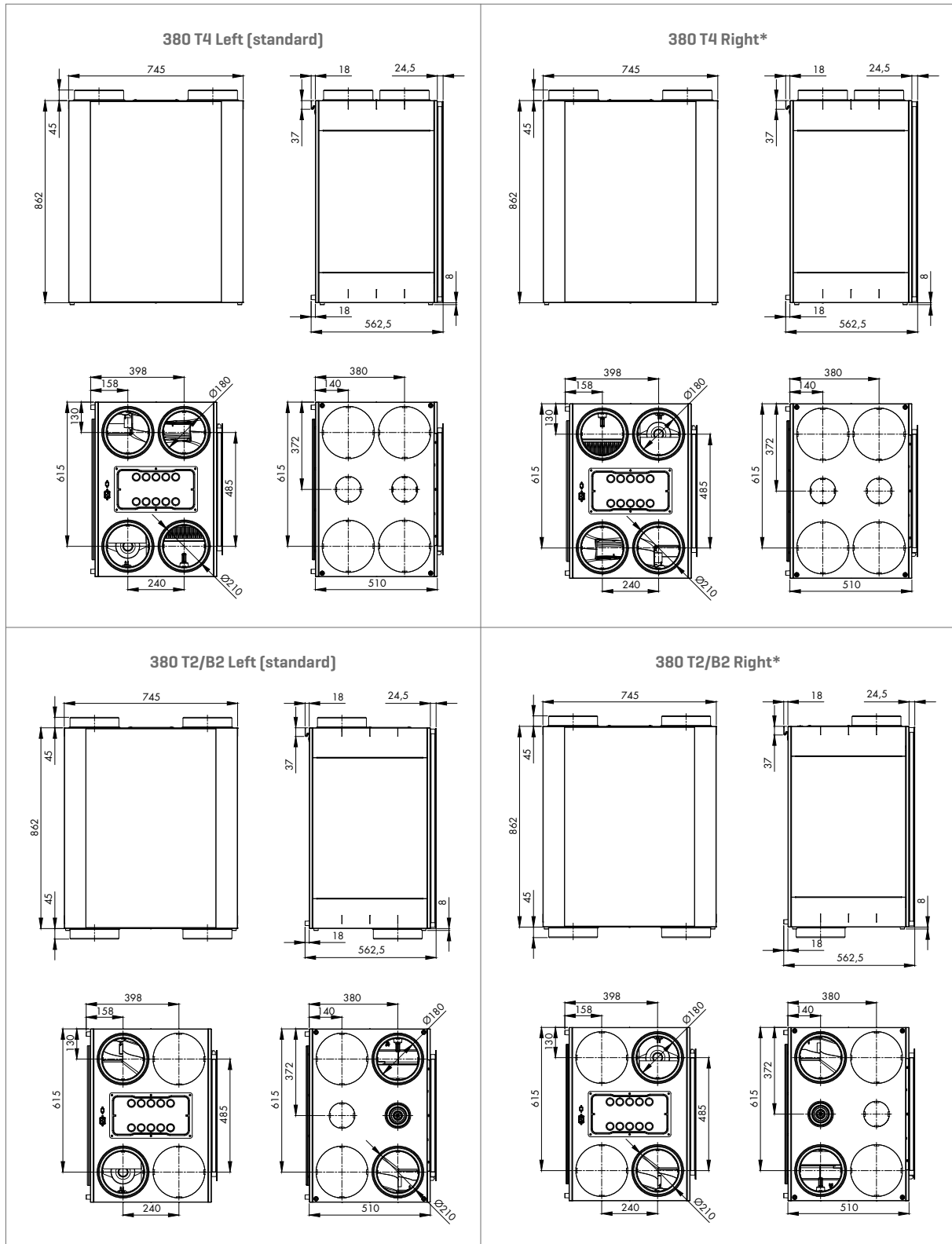

* Only possible after conversion.

TECHNICAL DATA SHEET:

Endura® Delta 450

AREA OF APPLICATION

- Can be used in new constructions
- Mechanically supplied fresh air
- Mechanically drainage of used air
- Demand-driven ventilation thanks to integrated air quality sensors
- High-efficiency heat exchanger for energy saving



Endura Delta 450 T4

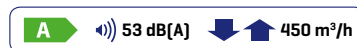

Endura Delta 450 T2/B2

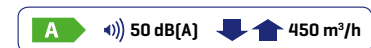

PRODUCT CHARACTERISTICS

EPB product data

- Max. capacity: 450 m³/h at 150 Pa
- Integrated plastic counter flow **heat exchanger**
- Maximum power consumption: 2 x 115 W

Ventilation system

- **Ventilators**
 - 2 EC motors
 - Supply voltage: 1 x 230V / 50Hz
 - Ventilators with backward-curved blades
 - Constant flow control: airflow remains constant
- Dimensions: H 862 x W 745 x D 520 mm
- Weight: 46 kg
- Available with 4 upper connections [T4] or 2 upper and 2 lower connections [T2/B2]
- Standard **left-hand model**, possible to convert to **right-hand model**
- Automatic **full bypass**
 - Modular control
 - Closing of the heat exchanger during warm weather
- 150/180 mm diameter connections **in expanded polypropylene**
 - Direct join to the unit:
 - EPP ducts: outer diameter 180 mm, inner diameter 150 mm
 - EPP ducts: with connecting sleeve: outer diameter 200 mm, inner diameter 180 mm
 - Other ducts: 180 mm diameter can be connected directly onto the ventilation system

- Integrated condensation drain Ø32 mm
- Extremely airtight appliance
- **2 x coarse [G4] cartridge filters** (PM1 [F7] optional for supply)
 - Maintenance-friendly
 - Large filter surface area
- **Integrated TouchDisplay** in front panel
 - Touchscreen
 - Possibility to configure and control ventilation unit
 - Error feedback
 - Filter message
 - Visualization of current ventilation conditions
- **Ethernet connection [RJ45 connector]**
 - Possibility to control unit via tablet /smartphone via local network
- **External input/output contacts**
 - **Open input contact [digital 0-24 V]**
 - Supply and extract disabling option – e.g. emergency OFF to switch off supply flow rate
 - Supply switch-off
 - Drainage switch-off
 - Activation of fireplace function via external contact
 - **Open output contact [digital 0-24 V]**
 - Error message
 - Filter message
 - **0-10V analogue input**
 - **0-10V analogue output**

TECHNICAL DATA SHEET:

Endura® Delta 450

FUNCTIONS

- Operation
 - According to automatic mode [program]
 - Manual control
 - Timers
 - Via integrated air quality sensors [RH, CO₂ & VOC]
 - Via optional, external air quality sensors
- **Demand-driven ventilation** thanks to integrated air quality sensors
 - Relative humidity
 - VOC [volatile organic compounds]
 - CO₂
 - Ventilation levels adapted in accordance with measured air quality
- Automatic **frost protection**
 - Temporary imbalance and flow restriction to prevent freezing of the heat exchanger
- Extra frost protection option through installation of **pre-heating element**
 - Electrical pre-heating element
 - Modular power
 - Max. power: 1000 W
- **Breeze function**
 - Breeze function for optimum cooling in summer [summer bypass with adjustable ventilation level]
 - Automatic and manual bypass activation
 - 4-seasons automatically controlled indoor temperature
- **Fireplace function**
 - Activated via external pulse switch
 - Temporary imbalance on supply side [overpressure] to aid ignition process
- Holiday mode
 - Input of start and end dates during prolonged absence
 - System ventilates at maximum energy efficiency
- Filter message
 - Via smartphone
 - On integrated TouchDisplay
 - On external control unit [optional]
 - Timer-controlled

CONTROL

- **With Endura Delta app**
 - iOS, Android and Windows
 - Smartphone and tablet
- **TouchDisplay on unit**
 - Power and communication with motor unit via RS232
 - Possibility to program the motor unit with the TouchDisplay

Options

- **Master air quality sensor [76050330]**
 - Display of air quality and ventilation intensity
 - Integrated air quality sensor
 - Display of active program
 - Timer programming possible
 - Power via motor unit [connect directly to the motor unit]
- **Slave air quality sensor [76050331]**
 - Always in combination with Master
 - Wireless communication with Master
 - Power voltage 230V / 50Hz
 - Integrated air quality sensor
 - Same information as on the Master available
- **4-position switch [on request]**
 - Limited functionality



Endura® Delta app



TouchDisplay

TECHNICAL DATA SHEET:

Endura® Delta 450

MODELS

DESIGNATION	ARTICLE NUMBER
Endura Delta 450 T4	76050808
Endura Delta 450 T4 PH	76050809
Endura Delta 450 T2/B2	76050810
Endura Delta 450 T2/B2 PH	76050811

Endura Delta 450 Left [standard]

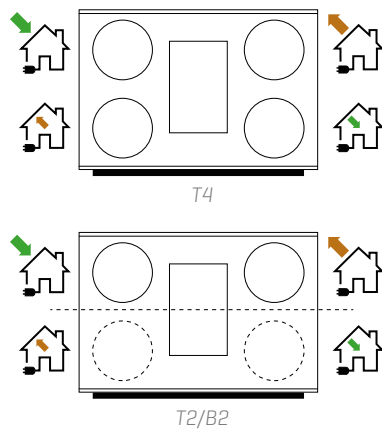

Endura Delta 450 Right [only possible after conversion]

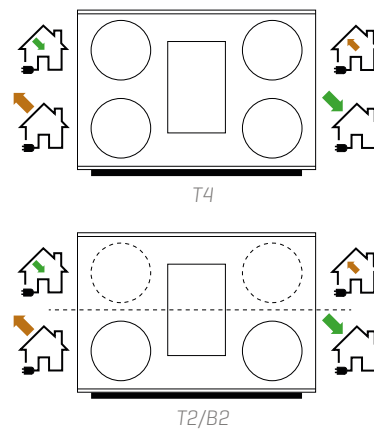

PRESSURE CURVES

Fan curves for the Endura Delta 450
pressure based on flow rate

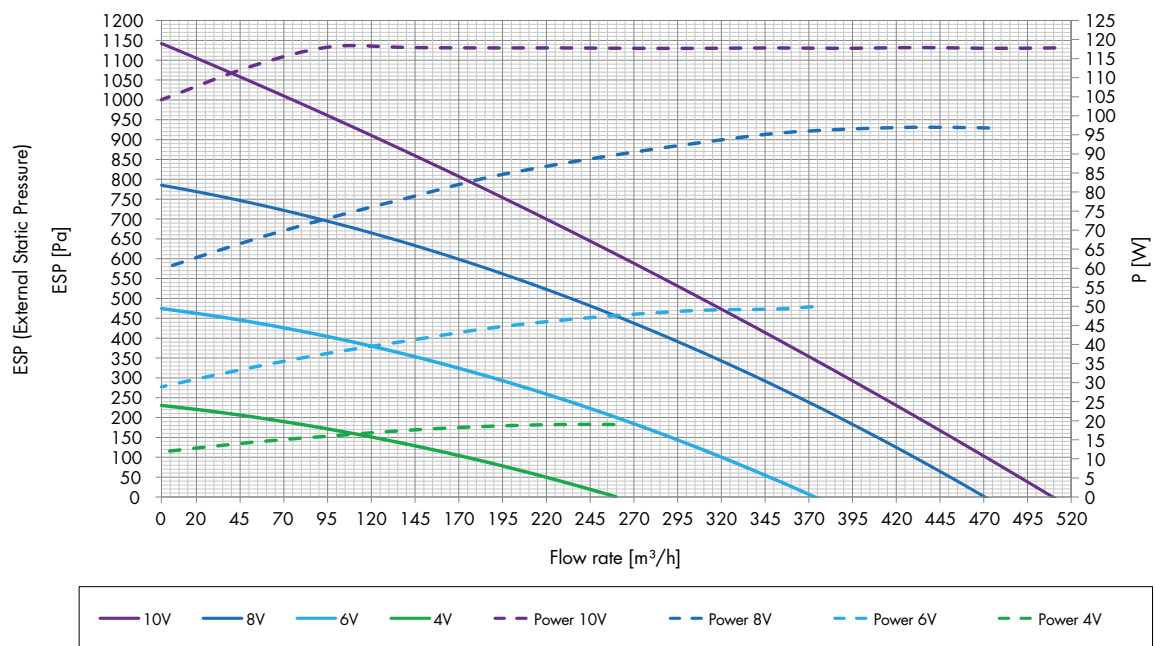

TECHNICAL DATA SHEET:

Endura® Delta 450

TECHNICAL DRAWINGS

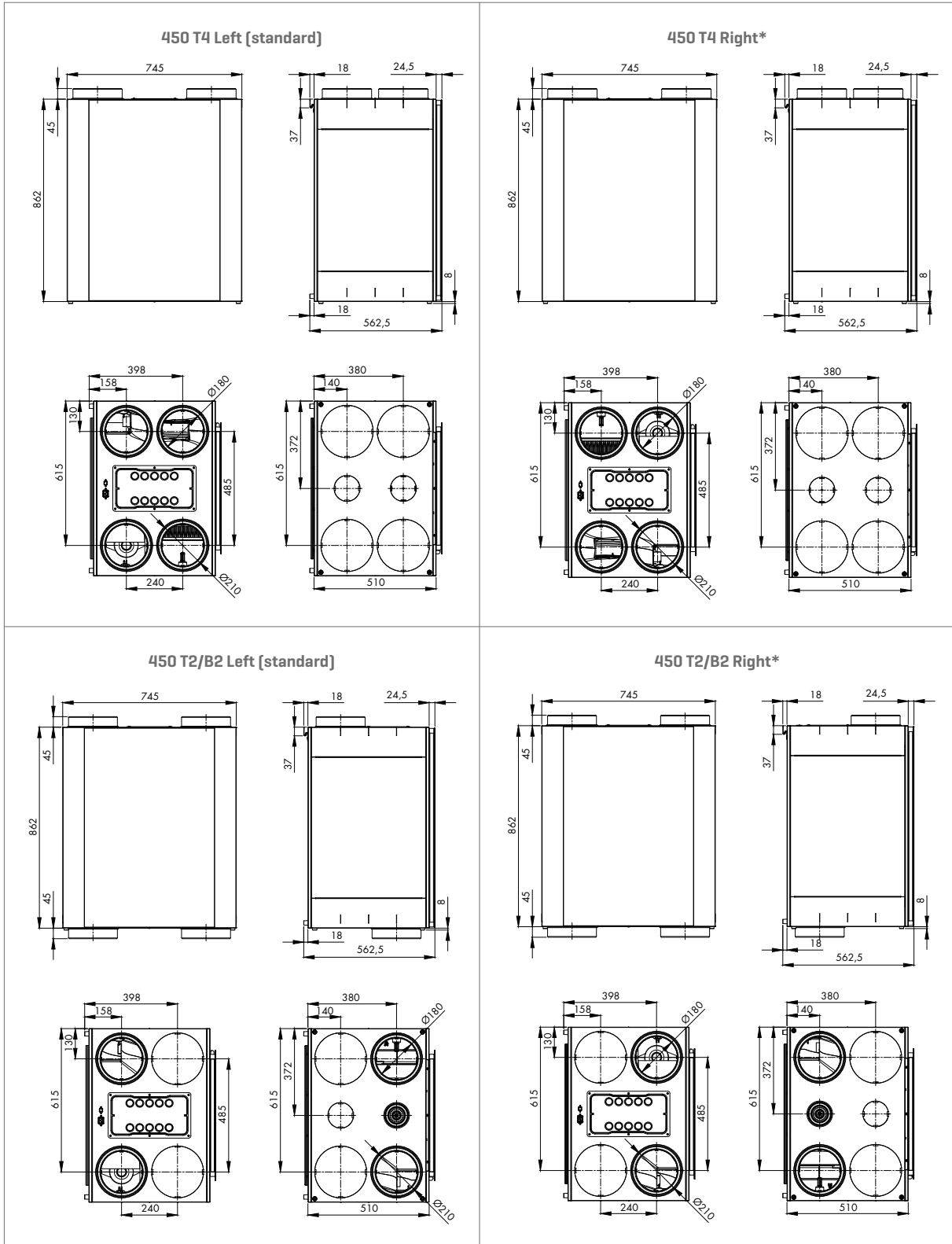

* Only possible after conversion.

TECHNICAL DATA SHEET:

Overview Endura® Delta

COMPARISON ENDURA DELTA 330-380-450

Fan curves for the Endura Delta pressure based on flow rate

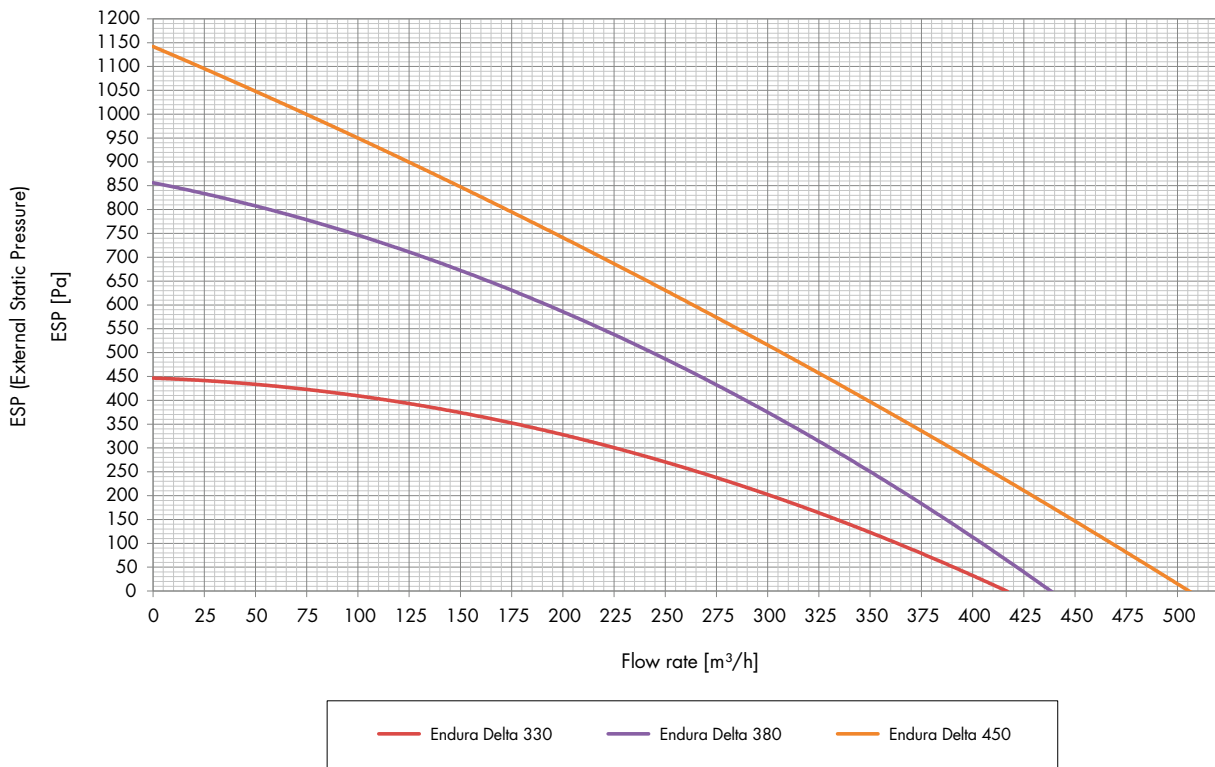

MODELS

Description	Item no.	Description	Item no.	Description	Item no.
ED 330 T4	76050800	ED 380 T4	76050804	ED 450 T4	76050808
ED 330 T4 PH	76050801	ED 380 T4 PH	76050805	ED 450 T4 PH	76050809
ED 330 T2/B2	76050802	ED 380 T2/B2	76050806	ED 450 T2/B2	76050810
ED 330 T2/B2 PH	76050803	ED 380 T2/B2 PH	76050807	ED 450 T2/B2 PH	76050811

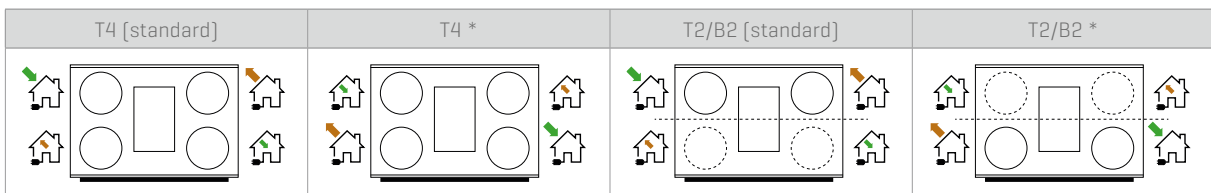

* Only possible after conversion.

TECHNICAL DATA SHEET:

Overview Endura® Delta

TECHNICAL SPECIFICATIONS

	Endura Delta 330	Endura Delta 380	Endura Delta 450
Flow rate	330 m³/h at 150 Pa	380 m³/h at 150 Pa	450 m³/h at 150 Pa
Fans	EC fan with forward curved blades, constantly driven by volume	EC fan with backward curved blades, constantly driven by volume	EC fan with backward curved blades, constantly driven by volume
Max. power	2 x 85 W	2 x 83 W	2 x 115 W
Max. power preheater	1000 W	1000 W	1000 W
Heat exchanger	PS	PS	PS
Thermal yield measured according to EN308	89% at 100 m³/h 87% at 150 m³/h 84% at 250 m³/h 82% at 325 m³/h 81% at 350 m³/h	88% at 100 m³/h 85% at 200 m³/h 83% at 300 m³/h 81% at 400 m³/h	87% at 100 m³/h 83% at 250 m³/h 81% at 350 m³/h 79% at 470 m³/h
Connections	Ø 180 mm 4 upper connections [T4] 2 upper and 2 lower connections [T2/B2]	Ø 180 mm 4 upper connections [T4] 2 upper and 2 lower connections [T2/B2]	Ø 180 mm 4 upper connections [T4] 2 upper and 2 lower connections [T2/B2]
Bypass	Modulating	Modulating	Modulating
Filters	2 x coarse [G4] PM1 [F7] optional	2 x coarse [G4] PM1 [F7] optional	2 x coarse [G4] PM1 [F7] optional
Controls	Smartphone / Tablet Optional: 4-position switch	Integrated TouchDisplay Smartphone / Tablet Optional: 4-position switch	Integrated TouchDisplay Smartphone / Tablet Optional: 4-position switch
Frost protection	Automatic through temporary imbalance Optional preheater [proportional and no imbalance]	Automatic through temporary imbalance Optional preheater [proportional and no imbalance]	Automatic through temporary imbalance Optional preheater [proportional and no imbalance]
Casing	Coated steel plate	Coated steel plate	Coated steel plate
Weight	41 kg	46 kg	46 kg
Materials inner part	Expanded Polypropylene	Expanded Polypropylene	Expanded Polypropylene
Condensate discharge	Integrated Ø 32 mm	Integrated Ø 32 mm	Integrated Ø 32 mm
Contacts	0-10 V IN/OUTPUTS	0-10 V IN/OUTPUTS	0-10 V IN/OUTPUTS
Sensors	Integrated temperature sensors Integrated humidity sensor Integrated VOC sensor Integrated CO ₂ sensor	Integrated temperature sensors Integrated humidity sensor Integrated VOC sensor Integrated CO ₂ sensor	Integrated temperature sensors Integrated humidity sensor Integrated VOC sensor Integrated CO ₂ sensor



TECHNICAL DATA SHEET:

Endura®

The RENSON® Endura® intelligently combines demand-controlled ventilation and air to water heat pump technology in a single machine.



APPLICATION SCOPE

- Suitable in new buildings and renovation.
- Helps achieve a “nearly zero-energy building [nZEB] with renewable energy”.
- Supply of fresh air via window ventilation
- Demand-controlled exhaust of ventilation air.
- Heat production for space heating and domestic hot water.
- Indoor installation, no need for an outdoor unit.
- Hybrid installation - combine with a Solo boiler.
- Integrated water cylinder [300 liter].

MAIN FEATURES



1 Central fan

- Exhaust of contaminated ventilation air and draws in outside air.
- Modulated speed regulation of the motor ensures that energy consumption is minimal. The required air flows are always set at the lowest possible pressure level.

Demand-controlled ventilation

- Good air quality and heat economy guaranteed.
- Unique automatic calibration system: guarantees the correct ventilation air flow.
- Regulation of exhaust flow rate based on measured air quality.

Optional Breeze function

- At high temperatures, the ventilation air flow is increased to cool the building with a supply of cooler outdoor air by means of window ventilation.

Heating

- By means of an integrated Air-to-Water Heat Pump.
- Draws heat from a mixture of outside air and exhausted ventilation air.
- Reuse of the ventilation air ensures a higher coefficient of performance [COP].
- Ventilation flow rate independent of heat demand, by means of modulated outdoor air valve.
- Two separate condenser circuits for space heating and domestic hot water.
- Direct condenser circuit, by means of the spiral around the boiler cylinder, greatly improves efficiency.
- Low power consumption.

Hybrid installation

- Combine with Solo boiler.
- Energy Analyser: the production of heat is always generated in the most economically and ecologically efficient way.
- The hybrid installation makes it possible to heat simultaneously at a low and a high water temperature.

TECHNICAL DATA SHEET:

Endura®

NAME	ITEM NUMBER
Kit Endura® 300 <i>contains Endura® 300 unit + kit of ventilation accessories for Endura® 300</i>	76050300
Kit Endura® 300 Smartzone <i>contains Endura® 300 unit + kit of ventilation accessories (Smartzone) for Endura® 300</i>	76050310

SYSTEM CHARACTERISTICS	
Type of system	Monobloc
Installation	Indoor installation (ambient temperature 2 - 40°C)
Integrated ventilation system	✓
Heat generated via integrated heat pump technology	✓
Dimensions Endura® (without ventilation collector)	640 x 654 x 1863 mm (W x D x H)
Weight (empty)	146 kg
Supply voltage	230 Vac (50 Hz)
Unit circuit protection	10 A safety fuse / 16 A automatic fuse
Input power Endura®	715 W <i>At an outdoor air temperature of 2°C and water temperature regime of 35/30°C (in accordance with EN14511-2)</i>
- Connection for supply of outdoor air and exhausted indoor air via ventilation collector - Connection for exhausted air to the outdoors	ø150
Hydraulic connections	Space heating: 1" female Domestic Hot water: 3/4" female
Ventilator	Energy-efficient EC motor
Maximum ventilator capacity	67 W
Control	- Touch control panel on the Endura® - Wireless control for inside the building (230 V)

CONTROL	
Air quality display	✓ Via wireless control in the building, displays air quality at the location of control unit
Temperature display and display of available domestic hot water supply	✓ Via wireless control in the building and on the control panel Endura®

VENTILATION PROPERTIES	
Max ventilation air flow Endura® unit	400m³/h at 200 Pa <i>(available pressure level without connected elements, such as filter box, ventilation collector...)</i>
Type of ventilation	Demand-controlled exhaust*, mechanical. Supply via window ventilation
Detection of air quality (CO ₂ , VOC, humidity)	Via electronic sensors in control modules
Regulation of ventilation air flow per room	Via butterfly valve in control module. The electronic sensor determines the position of the butterfly valve.
Connection diameter of control modules	ø 125 or ø 80, depending on type of control module
Automatic flow adjustment of the ventilation air flow (calibration)	✓
Adjustment time for automatic flow adjustment	Average of 8 minutes for 3 control modules
Readout of pressure adjustment	✓
Breeze	✓ Logic module for an increase of supply of cold outdoor air during the summer
Ventilation collector	Thermally insulating EPP material -
Maximum number of connection points for the ventilation collector	Type 1: 6x control modules ø80 + 2x control modules ø125 Type 2: 2x control module ø80 Type 3: 2x control module ø125
Can the ventilation collector connection points be increased?	✓ <i>(maximum 12 control modules per ventilation collector bloc and a maximum total of 24)</i>

* Demand control identical to C^{EV0} II (smartzone)

TECHNICAL DATA SHEET:

Endura®

HEAT PRODUCTION PROPERTIES		
Integrated heat pump	Type Air/Water, without outdoor unit	
Extraction of heat from	Combination of outdoor air and exhausted ventilation air	
Integrated heat pump refrigerant	R134a [GWP: 1430]	
Refrigerant capacity amount	1,2kg [CO ₂ - eq. 1,72 tons]	
Production of Domestic Hot Water [DHW]	✓	
Space heating [CH]	✓ For low-temperature heat transfer systems	
2 condenser circuits	- Domestic Hot Water: spiral around the boiler cylinder - Space heating: plate heat exchanger	
Material of spiral around the boiler cylinder	Aluminium	
Material of plate heat exchanger	RVS AISI 304	
Useful heat output	- Space heating 2.67 kW* - Domestic Hot Water 3.5 kW	
Coefficient of Performance COP	- Space heating 3,94* - Domestic Hot Water 4.00	
Renewable energy / SPF for EPB Flanders	In accordance with the EPB value scale , available on request	
Maximum supply temperature to heating section	Via integrated heat pump technology	In hybrid installation with boiler
Space heating	55°C	90°C
Domestic Hot Water	60°C	70°C
Integrated water cylinder	Stainless steel 316L, insulated with CFC-free PU foam	
Volume of water cylinder	300 litres <i>(useful volume 285 litres)</i>	
Protection of water cylinder	Electric with titanium anode <i>(anode does not need to be replaced)</i>	
Water flow for space heating	Minimum 5l/min., maximum approx 30l/min. <i>Pressure drop over Endura® in function of air flow for space heating available on request</i>	
Maximum input temperature for the plate heat exchanger	55°C	
Heating time for the water cylinder from 15°C to 50°C via integrated heat pump technology	3 h 17 min <i>(air temperature at 15°C in accordance with EN16147)</i>	
Energy Analyser	✓ Adjusts Economy - Ecology. Based on actual COP of the heat pump technology, energy prices and the desired level of comfort	
Input of energy prices	✓	
Anti-legionella	✓	
Automatic defrost cycle	✓ Via air ventilation and direct heating via the compressor	
Frost protection	✓ Heating (plate heat exchanger) and boiler cylinder	
Operating range of evaporator	Minimum supply temperature of -5°C combined air	
Outdoor air valve	Thermally insulated EPP material	
Operation of outdoor air valve	Modulated In heating mode the outside air valve ensures an automatic adjustment so that the ventilation air flow is supplemented with outside air to ensure the evaporator receives a constant air flow of 350 m ³ /h.	
Electrical heating element	NONE. Extra heating capacity via boiler in hybrid mode	

* Outdoor air at a temperature of 2°C and water temperature regime of 35/30°C [in accordance with EN14511-2]

TECHNICAL DATA SHEET:

Endura®

HYBRID INSTALLATION WITH BOILER	
Integrated boiler	-
Type of boiler	Solo boiler
Boiler connected to Endura® boiler cylinder	Via internal spiral heat exchanger
Boiler connected to Endura® for space heating	Hydraulic serial connected to the heating circuit
Communication with Solo boiler	Via OpenTherm protocol or via ON/OFF control

Basic hydraulic diagrams of the hybrid installations are available at: <http://www.renson.be/nl/technische-tekeningen-systeem-e+.html>

OTHER	
Automatic error message	✓
Integrated SD card	✓ To log data and update software

TECHNICAL DRAWING

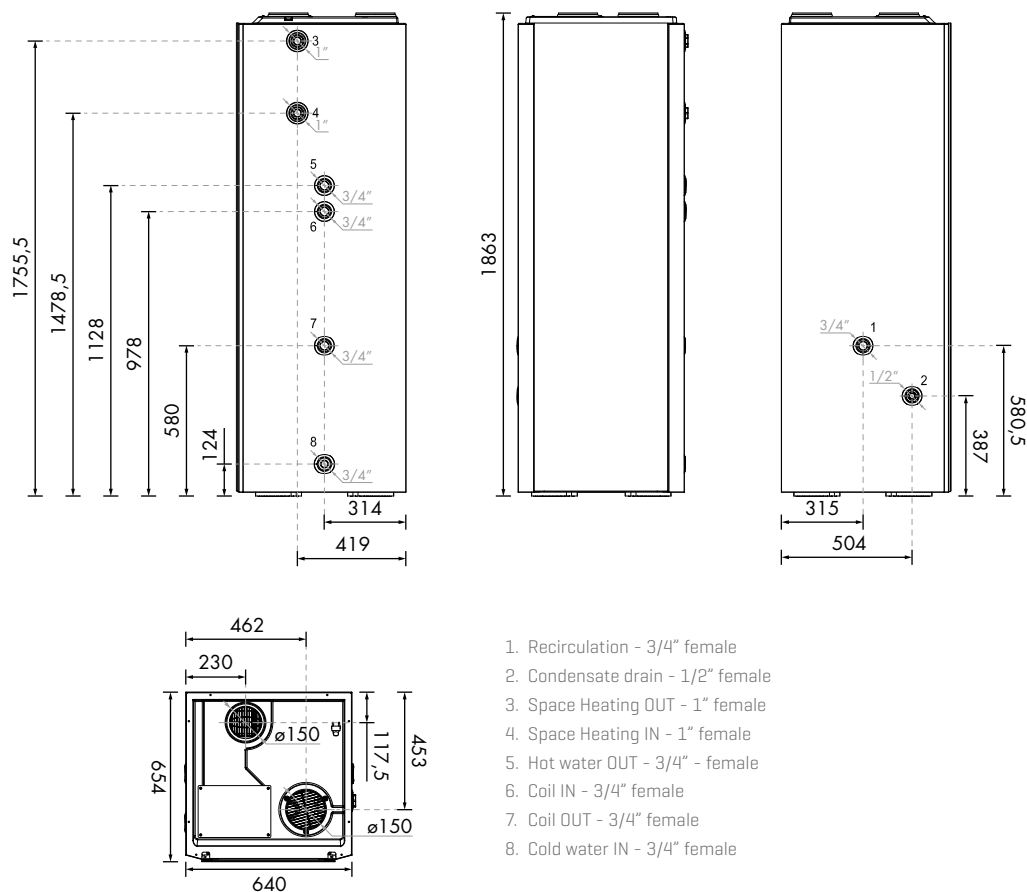

Basic hydraulic diagrams of the ventilation collector are available at: <http://www.renson.be/nl/technische-tekeningen-systeem-e+.html>



TECHNICAL DATA SHEET:

Healthconnector®

The RENSON Healthconnector regulates the extracted [polluted] interior air for each room within centralised ventilation systems.

AREA OF APPLICATION

- Appropriate solution for integrating demand-controlled ventilation in buildings. The demand-controlled ventilation ensures that ventilation can take place in an energy-efficient manner, whilst maintaining good air quality and comfort.
- Can be used in buildings with a central ventilation system [extraction], both new construction and renovation.
 - Intake of fresh air by means of window air vents.
 - Extraction of air through central constant pressure fan[s].
- Individual regulation of ventilation per area.
- Plug & Play principle: Healthconnector can be integrated directly into the ducting network.
- The Healthconnector is being included in the best air control class IDA-C6 of the European ventilation standard for non- residential buildings [NBN EN 13779:2007].



TYPES OF IMPLEMENTATIONS

There are 6 different types of Healthconnectors:

- Types differing in diameter: Ø125, Ø200, Ø250
- Type Master or Slave

Name	Article number
Master	
Healthconnector-G3 MASTER Ø125	66025092
Healthconnector-G3 MASTER Ø200	66025082
Healthconnector-G3 MASTER Ø250	66028087
Slave	
Healthconnector-G3 SLAVE Ø125	66025093
Healthconnector-G3 SLAVE Ø200	66025083
Healthconnector-G3 SLAVE Ø250	66025088

TECHNICAL DATA SHEET:

Healthconnector®

KEY FEATURES

Master Healthconnector®

- Integrated CO₂ sensor and humidity sensor. Both sensors measure the interior air quality in the extracted airflow 24 hrs/ day.
- The stepper motor automatically positions the internal butterfly valve based on the measured CO₂ and/or the relative humidity concentration. The flow rate is thus regulated depending on the interior air quality.
- CO₂ treshold of the Healthconnector is adjustable via the [optional] controller. The treshold set ensures that the CO₂ level is not exceeded in the connected area[s].
- Possibility of [temporary] manual adjustment of the ventilation exhaust airflow rate by means of the [optional] controller.
- The Master Healthconnector is provided by default with a connection for controlling a Slave Healthconnector and/or a motorised intake louvre.
- The Master Healthconnector can be controlled via a Building Management System [BMS] [0-10 V].

Slave Healthconnector®

- The Slave Healthconnector is a compliant valve without integrated sensors and is driven by the Master Healthconnector.
- The positioning of the butterfly valve is determined by the Master Healthconnector.
- The Slave Healthconnector can be powered by a separate power supply, or can be powered from the Master. Thanks to the Plug & Play principle, up to 6 Slave valves can be powered from one Master valve.

Arrangement with Master Healthconnector® and Slave Healthconnector®

When larger ventilation flow rates are necessary [$> 600 \text{ m}^3/\text{h}$], the Master-Slave combination may be used. The total discharge flow rate is thus the sum of the individual Healthconnector flow rates. In this respect, a mixture of different types of Healthconnectors is allowed.

TECHNICAL DATA SHEET:

Healthconnector®

COMPOSITION OF THE HEALTHCONNECTOR®

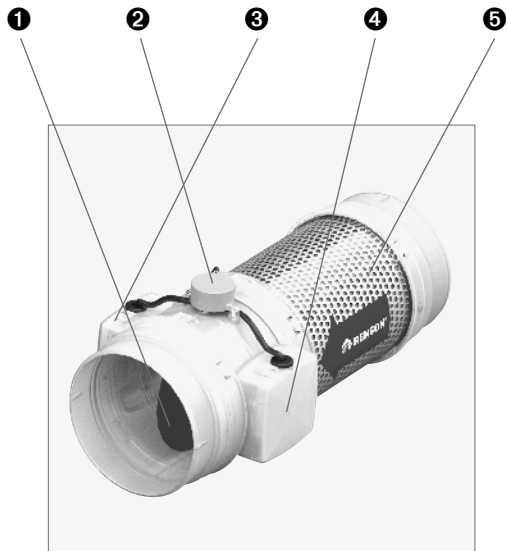

Master
Ø125



Master
Ø200/250

	Master	Slave
❶ Butterfly valve	•	•
❷ Stepper motor	•	•
❸ Unit's printed circuit board	• [with humidity sensor]	• [without humidity sensor]
❹ CO ₂ sensor	•	-
❺ Noise attenuator	• [only Ø125]	• [only Ø125]

Healthconnector Ø125	<ul style="list-style-type: none"> Valve halves are made of polypropylene Butterfly valve is made of ABS [Acrylonitrile-butadiene-styrene] Integrated noise attenuator is made of: <ul style="list-style-type: none"> Perforated sheet 395 mm x 200 mm x 1 mm – 40% open area Acoustic "egg box" foam 260 mm x 358 mm F0.5/N0.5, thickness 12 mm
Healthconnector Ø200/250	<ul style="list-style-type: none"> Valve halves are made of ABS Closing cover is made of polypropylene Butterfly valve and connecting flange are made of galvanised steel

Muting noise attenuator Healthconnector Ø125	5.7 dB [= the actual difference between the sound pressure level of a source with and without provision, measured at the same Healthconnector Ø125 position under the same conditions]
-------------------------------------------------	----------------------------------------------------------------------------------------------------------------------------------------------------------------------------------------

TECHNICAL DATA SHEET:

Healthconnector®

TECHNICAL SPECIFICATIONS

Type	Healthconnector 125		Healthconnector 200		Healthconnector 250	
	Master	Slave	Master	Slave	Master	Slave
Connection diameter	Ø125		Ø200		Ø250	
Flow rate [max.]	125 m³/h (= maximum air velocity of 2.8 m/s)		400 m³/h (= maximum air velocity of 3.5 m/s)		600 m³/h (= maximum air velocity of 3.5 m/s)	
Muting	•	•	-	-	-	-
Sensors integrated	CO ₂ and H ₂ O*	-	CO ₂ and H ₂ O*	-	CO ₂ and H ₂ O*	-

* H₂O: relative humidity

Adjustment	
Adjustment of nominal valve position when fine-tuning	In 16 steps from fully open to fully closed
Adjustment of butterfly valve in normal operation	From 10% to 100% nominal valve position
Adjustment CO ₂ [only Master Healthconnector]	<p>Adjustment of extracted airflow: Linear adjustment according to the set CO₂ threshold.</p> <p>Opening of butterfly valve: Proportionally in seven steps depending on the measured and set CO₂ threshold value, from 10% up to 100% of the nominal valve position.</p>
CO ₂ threshold value to be set with the Master Healthconnector [by means of optional 4 position switch]	<ul style="list-style-type: none"> - 600 ppm - 800 ppm - 900 ppm - 1000 ppm - 1100 ppm - 1200 ppm - 1400 ppm - 1600 ppm
Adjustment of humidity [only Master Healthconnector]	<p>Adjustment of extracted airflow: Responds to a large increase in or a large absolute value of relative humidity. The values are set to a fixed definition.</p> <p>Opening of butterfly valve: Opening from 10% to 100% of the nominal valve position on detection of humidity.</p>
Adjustment of Slave Healthconnector	Master Healthconnector adjusts the position of the butterfly valve of the Slave Healthconnector via a control signal.

Connecting voltage of power supply	
All types of Healthconnectors	12 V AC, 12 V DC and 24 V DC [on the input of the Healthconnector]
Power can be looped through from each Healthconnector	Up to 6 slaves can be powered from 1 Master Healthconnector
Required amperage	<ol style="list-style-type: none"> 1. Current for 1 Healthconnector: I ≥ 0.5 A 2. If power is looped through: <ul style="list-style-type: none"> • Current for 1x Master + 4x Slave: I ≥ 1.0 A • Current for 1x Master + 5-6 x Slave: <ul style="list-style-type: none"> - Either I ≥ 1.5 A - or I ≥ 1.0 A if the power supply can deliver a peak current ≥ 1.5 A

TECHNICAL DATA SHEET:

Healthconnector®

OPTIONAL CONTROLLER

RENSON 4-position switch with LED indication

- During normal operation: ventilation extracted airflow rate manually adjustable (only possible with Master Healthconnector).
- Calibration: at least one 4-position switch is (temporarily) required for the calibration of the Healthconnector (both Master and Slave Healthconnector).

Connection:

- Connect via 10-core cable to the Healthconnector (Min. 10 x 0.34 mm², Max. 10 x 0.8 mm²).
- A maximum of two controllers (in parallel) can be connected to one Healthconnector.
- A maximum of one Healthconnector may be connected to each controller.

INSTALLATION

- The proper operation of the Healthconnector is only guaranteed if the following two matched components are present:
 - Supply: Self-regulating ventilation louvres (P3 and P4).
 - Extraction: Constant pressure-controlled centralised fan.
Set fan pressure so that the pressure on the Healthconnector does not exceed 200 Pa.
- Several Healthconnectors can be connected to a single central fan: Healthconnectors are installed in parallel.
- Positioning:
 - Interior environment (preferably within the insulated volume).
 - In the air duct of the connected room[s].
 - The Healthconnector can be positioned both horizontally and vertically.
- Calibration [manually]:
 - A controller (optional) is needed to start the calibration.
 - Measure the flow rate (with an anemometer) at the extraction grille in the location. Using the controller, the nominal flow rate of the Healthconnector should be set (= fixing the nominal position of the butterfly valve). Further fine-tuning can be done if necessary to the adjustable extraction grille.

EXTENSIVE APPLICATIONS

- Linking with building management system:
The Master Healthconnector can be controlled via an (external) building management system to adjust the ventilation airflow rate through the Healthconnector as per the logic of the building management system. The control of the building management system should be done via a 0-10 V voltage signal:
 - [0-1.25 V]: autonomous operation of the Healthconnector.
 - [3-9 V]: building management system controls the position of the butterfly valve of the Healthconnector. There are seven fixed defined positions to control.
- Link to supply louvre with motorised inner valve
The Healthconnector can be connected to RENSON motorised intake grilles (0-10 V signal). In this way, the motorised inner valve of the intake grille can be controlled depending on the interior air quality.

TECHNICAL DATA SHEET:

Healthconnector®

TECHNICAL DRAWING

Master	(A)	(C)	(E)
Slave	(B)	(D)	(F)

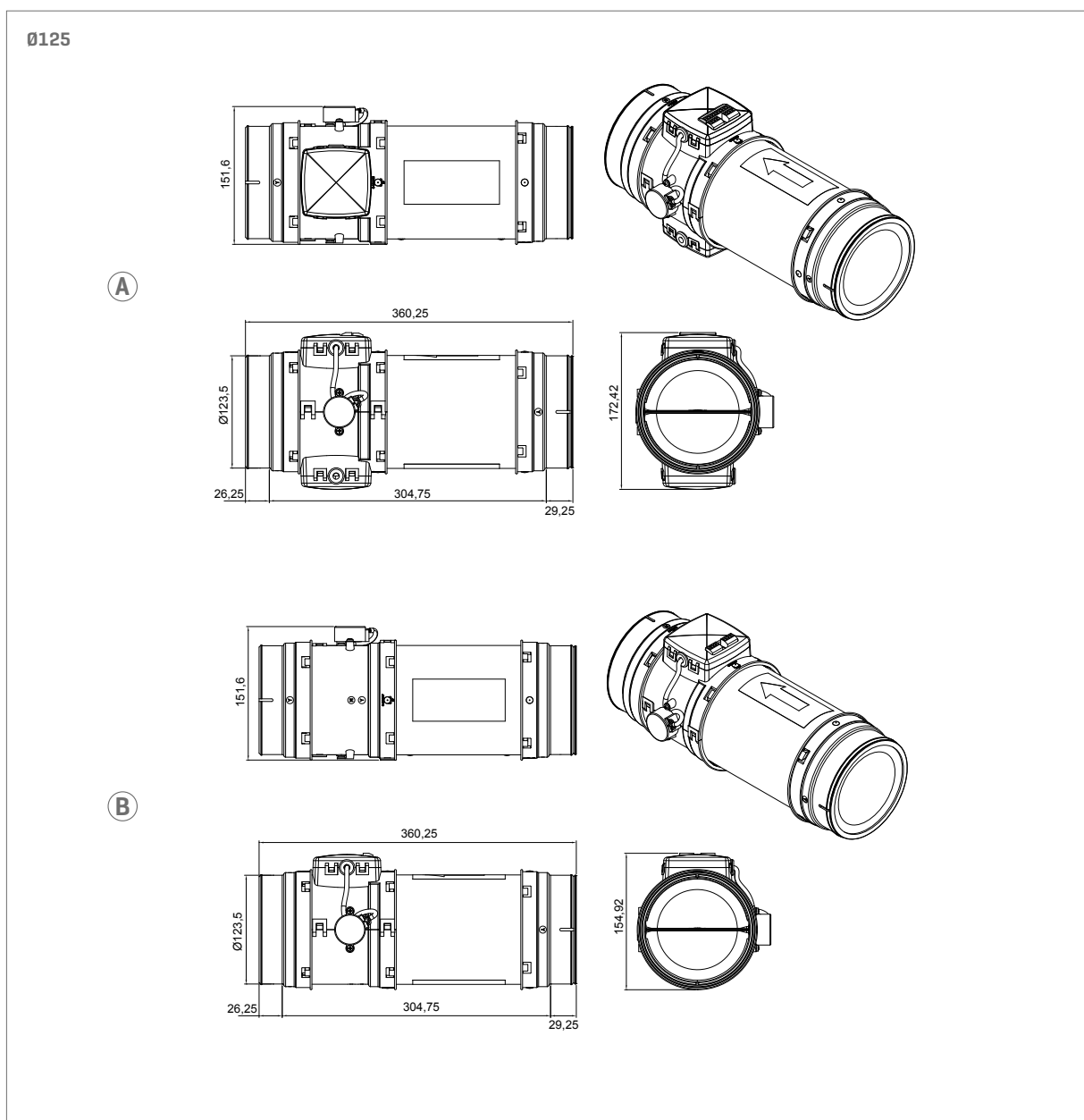

TECHNICAL DATA SHEET:

Healthconnector®

TECHNICAL DRAWING

Master	(A)	(C)	(E)
Slave	(B)	(D)	(F)

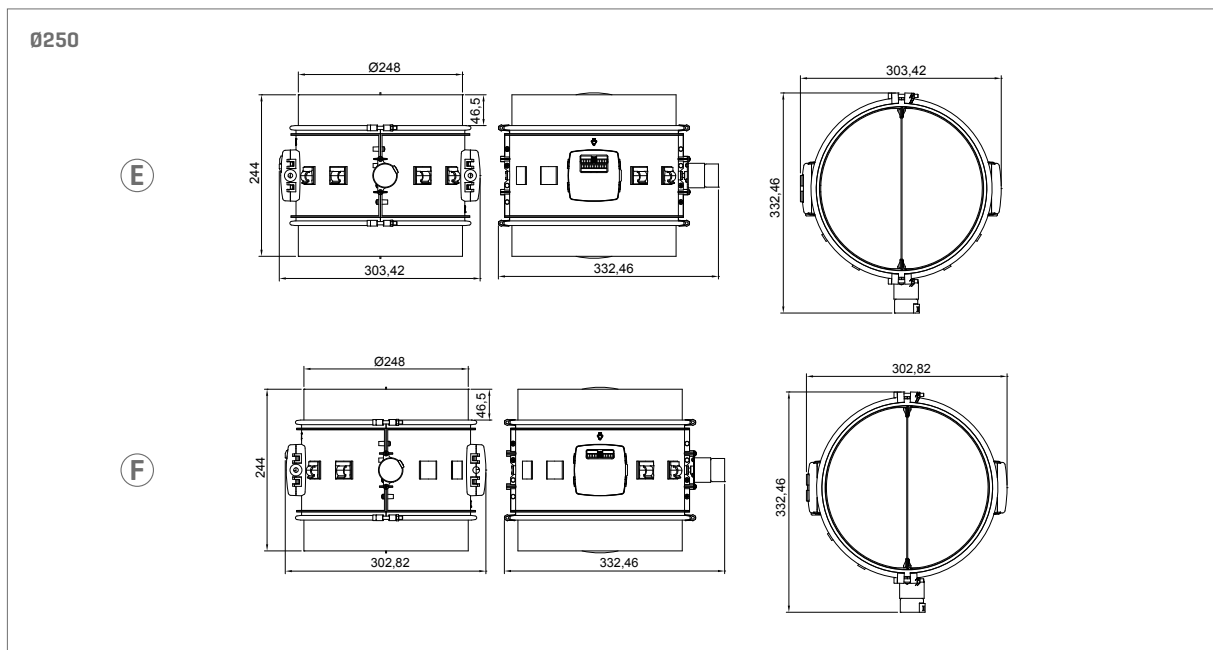
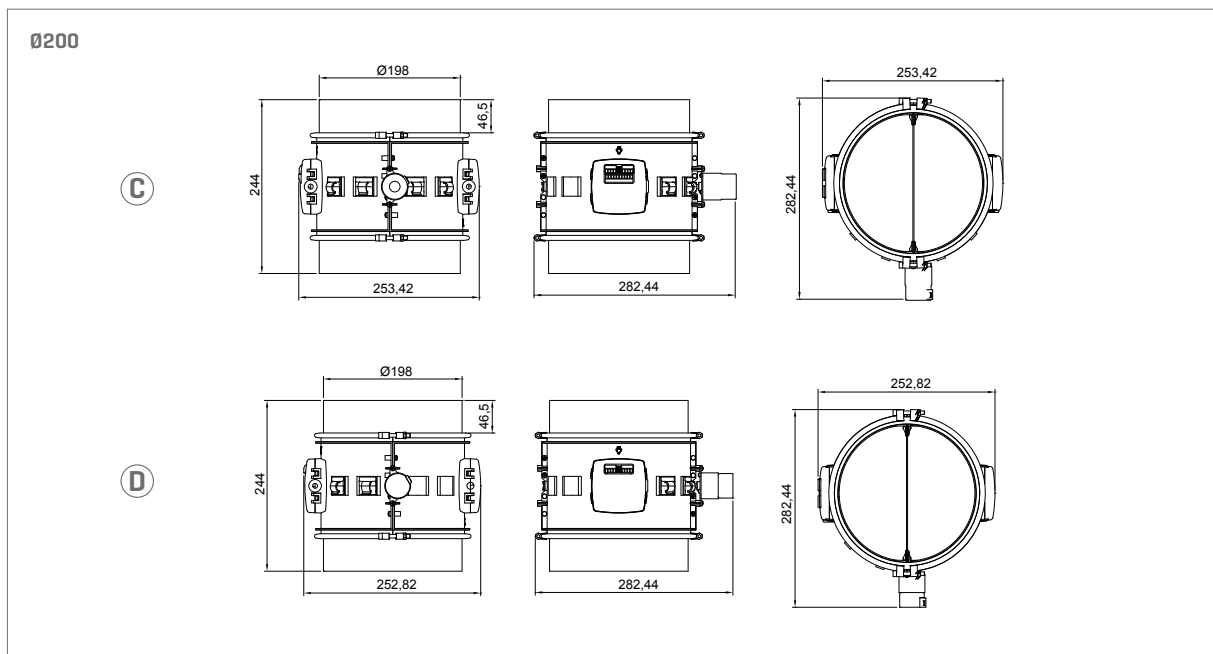

TECHNICAL DATA SHEET:

Grill frame with design grill

TYPES OF DESIGN GRILLS

There are 6 different design grills.

All design grills are available for connection to Ø 80 mm and Ø 125 mm grill frames.

The aluminium design grills are executed in RAL9010 matte [white], but can perfectly be repainted.

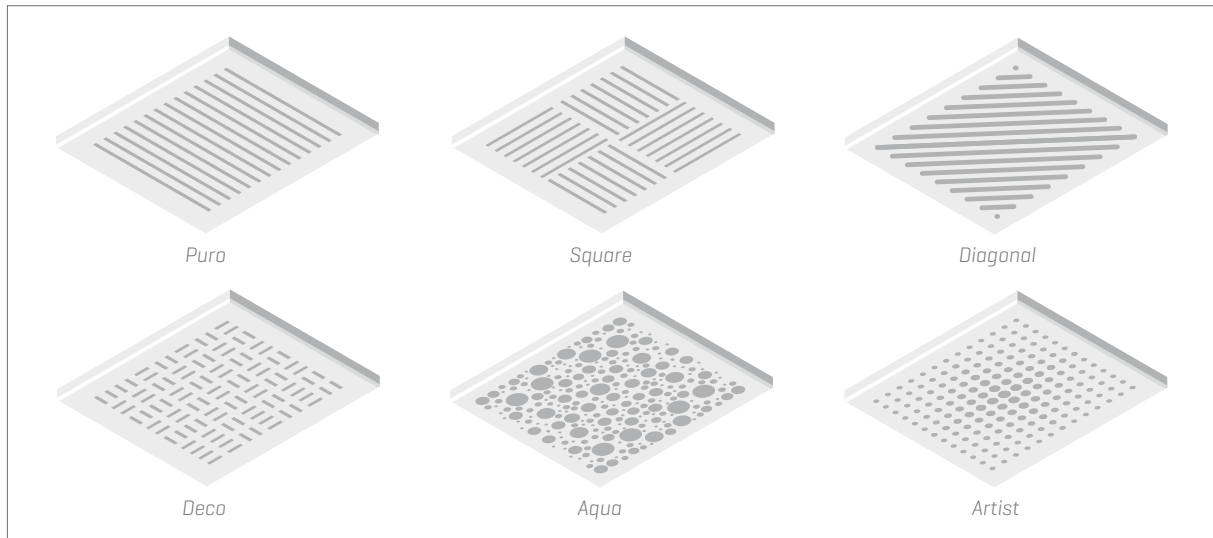

PRODUCT CHARACTERISTICS

Dimensions in mm

- Grill frame Ø 80 + design grill:
A = 134 / B = 130 / H = 11
- Grill frame Ø 125 + design grill:
A = 174 / B = 170 / H = 11

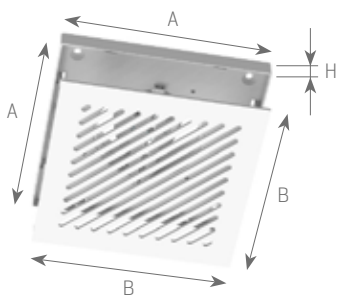







References

	Diameter 80 mm	Diameter 125 mm
Cover plate grill PURO	66031630 XD25-50 130 x 130, Ø 80	66031631 XD75 170 x 170, Ø 125
Cover plate grill SQUARE	66031632 XD25-50 130 x 130, Ø 80	66031633 XD75 170 x 170, Ø 125
Cover plate grill DIAGONAL	66031634 XD25-50 130 x 130, Ø 80	66031635 XD75 170 x 170, Ø 125
Cover plate grill DECO	66031642 XD25-50 130 x 130, Ø 80	66031643 XD75 170 x 170, Ø 125
Cover plate grill AQUA	66031636 XD25-50 130 x 130, Ø 80	66031637 XD75 170 x 170, Ø 125
Cover plate grill ARTIST	66031638 XD25-50 130 x 130, Ø 80	66031639 XD75 170 x 170, Ø 125
Grill frame modular	66031687 Ø 80 - 134 x 134 Modular - White	66031686 Ø 125 - 174 x 174 Modular - White
Grill frame non modular	66031675 Ø 80 - 134 x 134 White	66031676 Ø 125 - 174 x 174 White

TECHNICAL DATA SHEET:

Grill frame with design grill

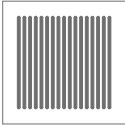
PRESSURE LOSS – AIRFLOW

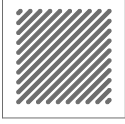
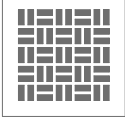
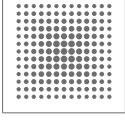
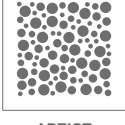
	Grill frame Ø 80 mm + Design grill Mounted on duct diameter 82 mm						Grill frame Ø 125 mm + Design grill Mounted on duct diameter 127 mm						
	Non modular execution		Modular execution				Non modular execution		Modular execution				
													
	Open		Open		Closed		Open		Open		Closed		
Qnom (m³/h)	ΔP (Pa)	Qnom (m³/h)	ΔP (Pa)	Qnom (m³/h)	ΔP (Pa)	Qnom (m³/h)	ΔP (Pa)	Qnom (m³/h)	ΔP (Pa)	Qnom (m³/h)	ΔP (Pa)	Qnom (m³/h)	ΔP (Pa)
 PURE	19,1	2	17,5	2	13,8	100	46,9	2	44,9	2	27,1	100	
	75	30,9	75	36,3	75	1661	75	5,1	75	5,6	75	462,1	
	50	13,7	50	16,2	50	847	50	2,3	50	2,5	50	250,9	
	25	3,4	25	4,1	25	267,8	25	0,6	25	0,6	25	88,3	
 SQUARE	20,2	2	18,5	2	13,3	100	48,5	2	46,7	2	26,2	100	
	75	29,1	75	33,9	75	2320,3	75	4,8	75	5,1	75	548,2	
	50	12,7	50	15	50	1110,5	50	2,1	50	2,3	50	284,3	
	25	3,1	25	3,7	25	315	25	0,5	25	0,6	25	92,5	
 DIAGONAL	19,1	2	17,6	2	13,8	100	48,5	2	46	2	26,9	100	
	75	31,8	75	37,3	75	1830	75	4,9	75	5,2	75	443	
	50	14	50	16,5	50	912,2	50	2,1	50	2,4	50	246,1	
	25	3,4	25	4,1	25	277,5	25	0,5	25	0,6	25	90,1	
 DECO	17,7	2	16,4	2	13,1	100	42,8	2	41,8	2	26,3	100	
	75	37,7	75	42,8	75	2053,9	75	6,2	75	6,4	75	506,5	
	50	16,5	50	18,9	50	1018,6	50	2,7	50	2,9	50	270,7	
	25	4	25	4,7	25	307,1	25	0,7	25	0,7	25	92,7	
 AQUA	18,5	2	17,2	2	13,3	100	43,6	2	41,9	2	25,8	100	
	75	33,8	75	39,4	75	1962,4	75	6	75	6,4	75	474,6	
	50	14,9	50	17,4	50	976,3	50	2,6	50	2,9	50	262,5	
	25	3,7	25	4,3	25	296	25	0,6	25	0,7	25	95,4	
 ARTIST	17,7	2	16,1	2	13,7	100	45,4	2	43,8	2	26,8	100	
	75	37,7	75	44,9	75	1768,9	75	5,4	75	5,8	75	455,3	
	50	16,6	50	19,8	50	892,3	50	2,4	50	2,6	50	250,5	
	25	4,1	25	4,9	25	277	25	0,6	25	0,7	25	90,2	

TECHNICAL DATA SHEET:

SQair valve

PRODUCT DESCRIPTION

- Adjustable valve available in 4 versions
 - Extraction valve:
 - Deluxe: aluminium front plate [lacquered RAL 9010]
 - Basic: synthetic front plate RAL 9010 [coloured plastic]
 - Pulse valve:
 - Deluxe: aluminium front plate [lacquered RAL 9010]
 - Basic: synthetic front plate RAL 9010 [coloured plastic]
- Construction: grid base + front plate
- Protrudes only 24 mm from the ceiling or the wall
 - The wider front plate conceals the ventilation openings
- Direct connection onto the air ducts
 - \varnothing 125 mm
 - Integrated rubber gasket for airtight connection
- Front plate:
 - Deluxe: attached with magnets to the grid base
 - Basic: snaps on the grid base
 - Easily disassembled for cleaning
 - Thanks to the locknut the settings remain during cleaning
- The pulse valve is provided with acoustic material
 - Prevents whistling noise at the valve
- The Deluxe pulse valve has 2 deflectors
 - 2 of the 4 ventilation opening can be closed using the deflectors
 - For example: If the valve is installed close to a wall, this side can be closed to prevent the collection of dust [will affect the flow rate]



PACKAGING

- ART. no.:
 - 76050400 Deluxe pulse
 - 76050403 Basic pulse
 - 76050401 Deluxe extraction
 - 76050404 Basic extraction
- Dimensions: 200 x 190 x 85 mm

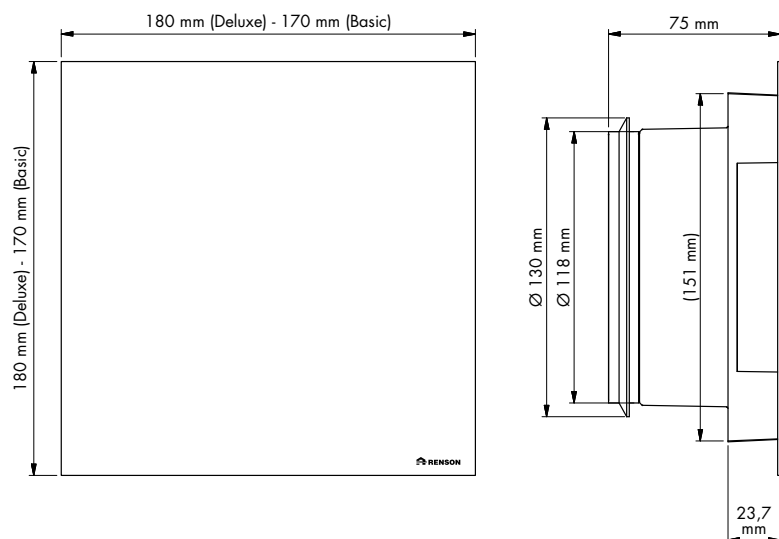

TECHNICAL DATA SHEET:

SQair valve

PRODUCT FEATURES

	DELUXE	BASIC
Front plate	Aluminium	Synthetic [ASA]
Dimensions front plate	180 x 180 mm	170 x 170 mm
Dimensions grid base	150 x 150 mm	150 x 150 mm
Colour	RAL 9010	RAL 9010
Attachment	Magnets	Snap-on
Paintable	Yes	-
Acoustic material	Yes [pulse]	Yes [pulse]
Deflectors	2	-
Dimensions deflector	92 x 20 mm	-

EXTRACTION

Q [m³/h]	Q [l/s]	100% open		66% open		33% open	
		dP [Pa]	LwA [dB(A)]	dP [Pa]	LwA [dB(A)]	dP [Pa]	LwA [dB(A)]
30	8.3	2	15,0	3	14,8	14	17,9
50	13.9	6	16,9	10	20,0	40	30,2
60	16.7	8	20,3	15	24,6	56	34,7
75	20.8	13	25,5	23	31,4	82	40,5

PULSE without acoustic material

Q [m³/h]	Q [l/s]	100% open		66% open		33% open	
		dP [Pa]	LwA [dB(A)]	dP [Pa]	LwA [dB(A)]	dP [Pa]	LwA [dB(A)]
30	8.3	3	15,0	5	15,1	14	24,5
40	11.1	6	16,3	8	18,8	25	33,5
50	13.9	8	17,5	12	22,5	37	39,9
60	16.7	11	19,3	17	28,0	54	45,5
75	20.8	16	24,5	26	35,0	83	51,5

PULSE with acoustic material

Q [m³/h]	Q [l/s]	100% open		66% open		33% open	
		dP [Pa]	LwA [dB(A)]	dP [Pa]	LwA [dB(A)]	dP [Pa]	LwA [dB(A)]
30	8.3	9	16,0	19	17,6	58	21,0
50	13.9	19	23,0	41	26,0	131	35,4
60	16.7	25	26,6	55	29,6	180	40,9
75	20.8	37	32,3	78	35,0	263	46,3

TECHNICAL DATA SHEET:

Flexible ducts - Aludec

RENSON® FLEXIBLE LAMINATED DUCTS: ALUDEC

RENSON ALUDEC is a flexible, strong laminate duct for various purposes. The duct consists of several layers of aluminium and polyester, with a high tensile steel spiral helix enclosed between the layers. The duct can be attached to round and oval connection parts without any problems.

Due to the "sandwich construction", the different layers of polyester and aluminium are overlapping each other completely. In case of fire, the system is able to function longer.



TYPES

REFERENCE	DESCRIPTION
66014103	Aludec-245 diameter 82 mm x 10 meter
66014104	Aludec-245 diameter 127 mm x 10 meter
66014107	Aludec-245 diameter 152 mm x 10 meter

APPLICATION

- General air supply systems, without special demands
- Air conditioning systems, without special demands

RESTRICTIONS

The Aludec ducts are not suitable for discharging combustion products from open fireplaces and oil-fired boilers. Neither are the Aludec ducts suitable for transporting air with a high concentration of acid and base.

SPECIFICATIONS

- Temperature range: -30 °C to 140 °C
- Operating pressure: max. +2500 Pa
- Operating air velocity: max. 30 m/s
- Bending radius: min. 0.54 x Ø
- Standard length: 10 m

CONSTRUCTION

- Number of layers: 5
 - whereof aluminium: 3 à 7 micron
 - whereof polyester: 2 à 12 micron
- Total thickness: 45 micron [without adhesive]
- Wire spacing: 18 mm
- Colour: aluminium

TECHNICAL DATA SHEET:

Flexible ducts - Aludec

The **Aludec** duct fulfills all the requirements and is qualified as specified within EN 13180: "Ventilation for buildings – Ductwork – Dimensions and mechanical requirements for flexible ducts".

The consultant is responsible for the actual installation and mounting of the product. The mentioned values with respect to temperatures are not appropriate to be used to determine the physical properties. These properties are also dependent on humidity and the temperature of the air inside and outside of the H.V.A.C. system.

DETERMINATION OF THE ACUTE TOXICITY

Stated by the "Institut für Arbeitsmedizin" of the medical faculty of the technical university of Aken. Under the supervision of prof. dr. med. H.J. Einbrodt [specialist] classified as "non toxic".

DIMENSIONS

	DIAMETER INNER FLEXIBLE	DIAMETER OUTER FLEXIBLE
Aludec 25 mm Ø 82	Ø 80	Ø 82
Aludec 25 mm Ø 127	Ø 125	Ø 127
Aludec 25 mm Ø 152	Ø 150	Ø 152

PRESSURE LOSS (stretched tube)

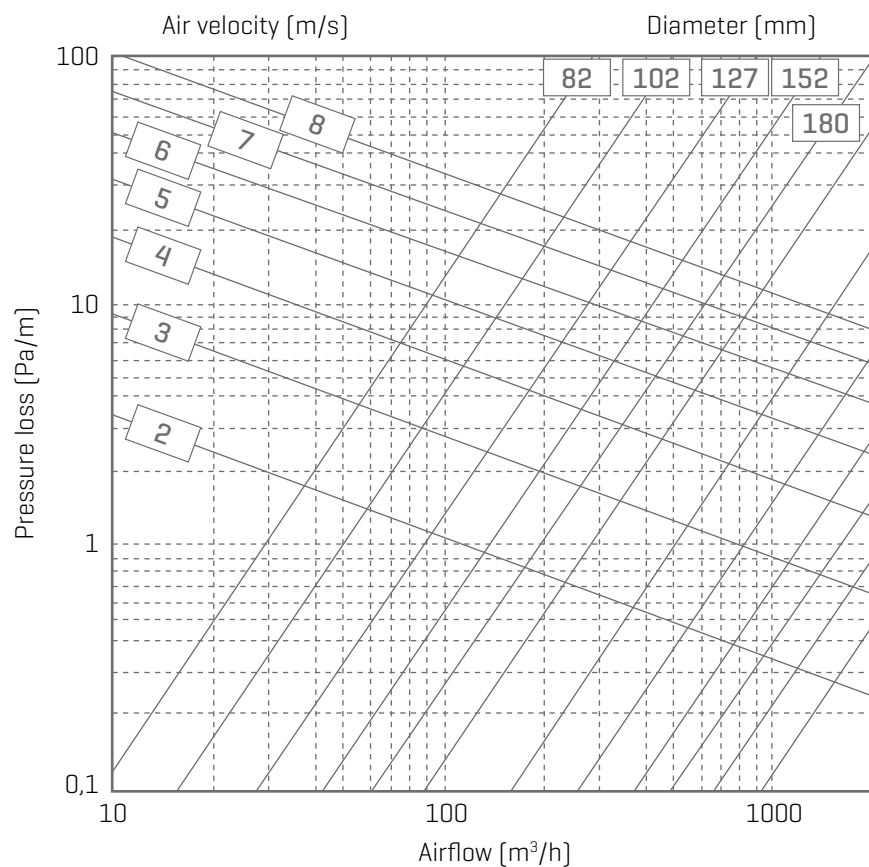

TECHNICAL DATA SHEET:

Flexible ducts - IsoDEC

RENSON® FLEXIBLE INSULATED DUCTS: ISODEC

RENSON ISODEC consists of an aluminium laminate inner duct, thermally insulated with a glass wool layer and provided with an aluminium laminated outer jacket.

The thermal insulation is suitable for preventing condensation and minimizing heat loss and loss of cold.



TYPES

REFERENCE	DESCRIPTION
66014100	Isodec diameter 82 mm x 10 meter
66014101	Isodec diameter 127 mm x 10 meter
66014106	Isodec diameter 152 mm x 10 meter
66014129	Isodec diameter 180 mm x 1 meter
66014138	Isodec diameter 162 mm x 10 meter

APPLICATION

- Insulation in air supply systems
- Ventilation systems
- Thermal insulation in order to prevent heat or cold loss
- Prevention / removal of condensation

RESTRICTIONS

The IsoDEC ducts are not suitable for discharging combustion products from open fireplaces and oil-fired boilers. Neither are the IsoDEC ducts suitable for transporting air with a high concentration of acid and base.

SPECIFICATIONS

- Temperature range: -30 °C to 140 °C
- Operating pressure: max. +2500 Pa
- Operating air velocity: max. 30 m/s
- Bending radius: min. $0.54 \times \varnothing + 25\text{mm}$
- Standard length: 10 m

CONSTRUCTION

- Inner duct: Alu/poly laminate
- Glass wool blanket: 25 mm, 16 kg/m³
- Outer jacket: Alu/poly laminate
- R-value glass wool: 0.65 m² K/W [ASTM C177-76]
- Colour: Aluminium

TECHNICAL DATA SHEET:

Flexible ducts - Isodec

The **Isodec** duct fulfills all the requirements and is qualified as specified within EN 13180: "Ventilation for buildings – Ductwork – Dimensions and mechanical requirements for flexible ducts".

The consultant is responsible for the actual installation and mounting of the product. The mentioned values with respect to temperatures are not appropriate to be used to determine the physical properties. These properties are also dependent on humidity and the temperature of the air inside and outside of the HVAC system.

DIMENSIONS

	DIAMETER INNER FLEXIBLE	DIAMETER OUTER FLEXIBLE
Isodec 25 mm Ø 82	Ø 80	Ø 82
Isodec 25 mm Ø 127	Ø 125	Ø 127
Isodec 25 mm Ø 152	Ø 150	Ø 152

PRESSURE LOSS (stretched tube)

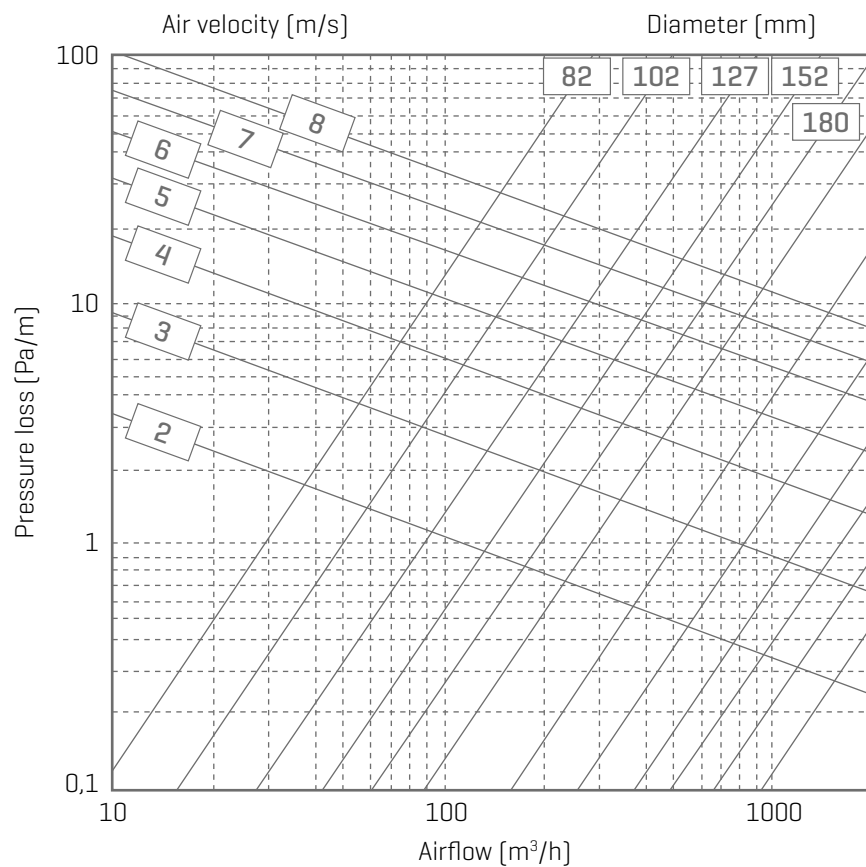

TECHNICAL DATA SHEET:

Flexible ducts - Acoudec

RENSON® FLEXIBLE SOUND DAMPER: ACOUDEC (25 mm - 0.5 or 1 meter)

The **RENSON ACOUDEC** consists of an inner tube of polypropylene fabric, thermal and acoustic insulated with fibreglass and a laminate outer cover with sealed ends for the connections.

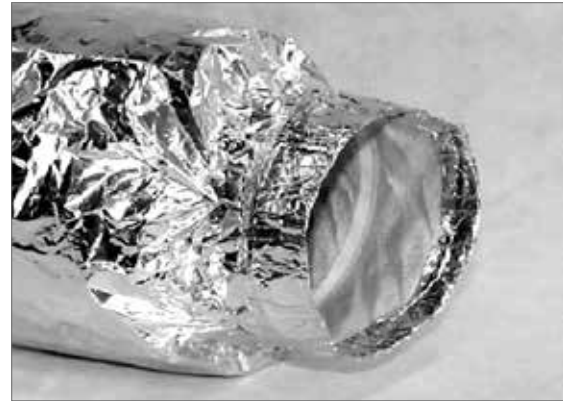

TYPES

REFERENCE	DESCRIPTION	REFERENCE	DESCRIPTION
66014133	Acoudec 25 mm Ø 82 x 0.5 meter	66014125	Acoudec 25 mm Ø 82 x 1 meter
66014134	Acoudec 25 mm Ø 127 x 0.5 meter	66014126	Acoudec 25 mm Ø 127 x 1 meter
66014135	Acoudec 25 mm Ø 152 x 0.5 meter	66014127	Acoudec 25 mm Ø 152 x 1 meter
66014136	Acoudec 25 mm Ø 162 x 0.5 meter	66014128	Acoudec 25 mm Ø 162 x 1 meter
-	-	66014139	Acoudec 25 mm Ø 180 x 1 meter
66014140	Acoudec 25 mm Ø 200 x 0.5 meter	66014141	Acoudec 25 mm Ø 200 x 1 meter

APPLICATION

- Ventilation systems: recommended use when the length of the extraction point to the ventilation unit ≤ 3m
- Sound dampening
- Machine sounds reduction

SPECIFICATIONS

- Temperature range: -30 °C tot 140 °C
- Working pressure: max. +2500 Pa
- Airspeed: max. 25 m/s
- Bow radius: 0.54 x Ø + 25 mm

CONSTRUCTION

- Inner tube: Non-woven polypropylene fabric
- Fibreglass: 25 mm, 16 kg/m³
- Outer cover: alu/poly laminate
- R-Value fibreglass: 0.65 m² K/W [ASTM C177-76]
- Exterior: aluminium

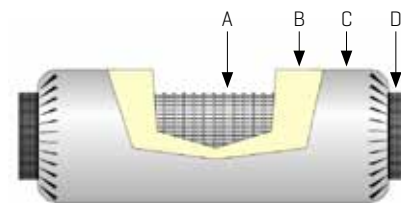

- A. Inner tube
- B. Fibreglass
- C. Outer cover
- D. Connexion

The **Acoudec** duct fulfills all the requirements and is qualified as specified within EN 13180: "Ventilation for buildings – Ductwork – Dimensions and mechanical requirements for flexible ducts".

TECHNICAL DATA SHEET:

Flexible ducts - Acoudec

DIMENSIONS

	DIAMETER INNER FLEXIBLE [A]	DIAMETER OUTER FLEXIBLE [C]
Acoudec 25 mm Ø 82	Ø 80	Ø 130
Acoudec 25 mm Ø 127	Ø 125	Ø 175
Acoudec 25 mm Ø 152	Ø 150	Ø 200
Acoudec 25 mm Ø 162	Ø 160	Ø 210

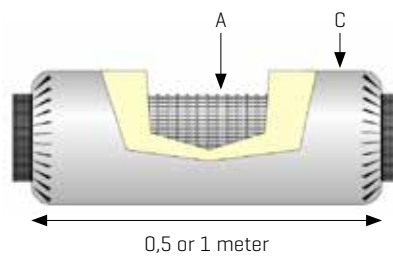

ACOUSTIC DAMPING

Dn [mm]	L [m]	Damping, dB - Mid-frequency, Hz								Di [dB]
		63	125	250	500	1000	2000	4000	8000	
Ø 80	0.5	18.2	9.3	27.2	28.8	26.4	33.2	48.7	31.7	30
Ø 125	0.5	14.8	8.1	19.1	20.7	19.9	26.4	26.7	13.0	35
Ø 150	0.5	16.9	4.0	11.1	16.7	19.7	28.5	19.4	12.0	33
Ø 160	0.5	10.2	7.8	11.2	17.3	18.8	26.1	17.7	12.5	32
Ø 80	1.0	13.6	22.4	40.2	38.7	36.5	41.3	51.6	45.8	39
Ø 125	1.0	11.7	18.9	32.4	29.9	28.8	34.5	40.9	24.5	32
Ø 150	1.0	12.2	10.9	29.7	30.1	29.0	38.3	34.6	20.4	32
Ø 160	1.0	19.3	25.4	30.5	27.1	23.8	32.2	27.8	17.3	28

Di = average damping [Test report number A1672-1 Peutz e.g. - The Netherlands]

TECHNICAL DATA SHEET:

Flexible ducts - Acoudec

PRESSURE LOSS (stretched tube)

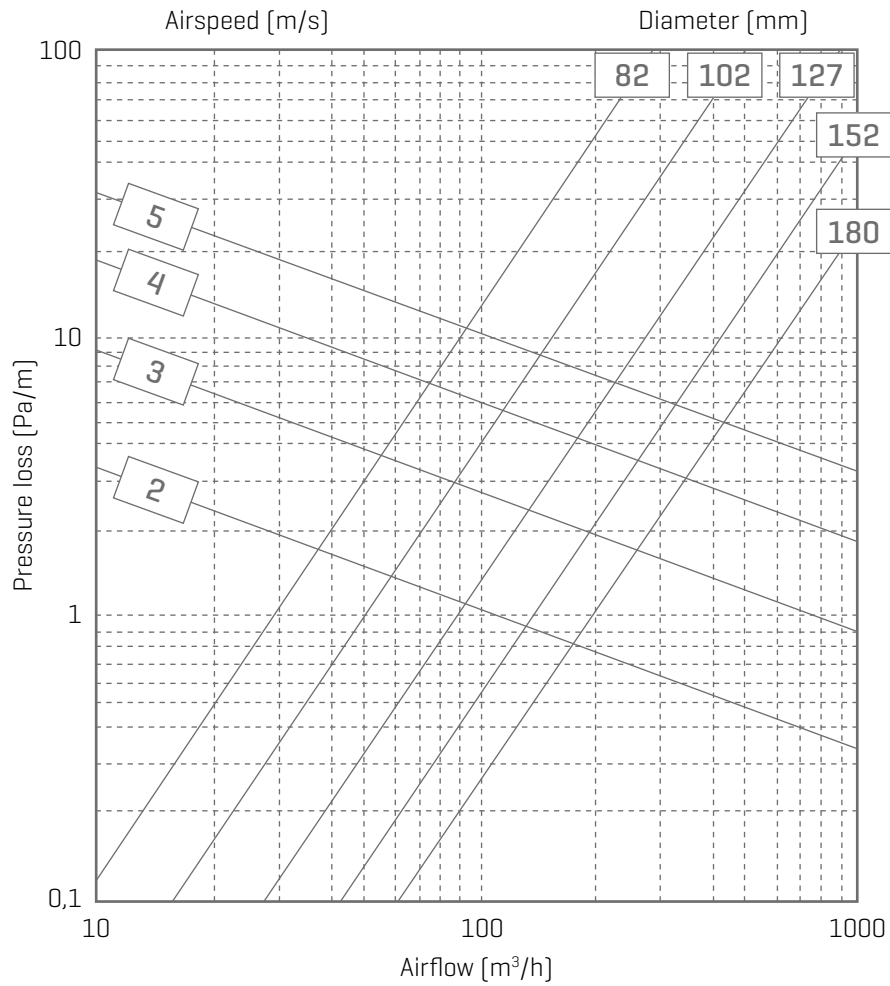

TECHNICAL DATA SHEET:

Insulated fixed ducts - Easyduct



76050311
Ventilation collector insulated EPP,
8 connections
[6 x Ø80 + 2 x Ø125] p. 138



76015012
Insulated EPP slave Ø150
black p. 145



76050312
Ventilation collector insulated EPP,
2 connections Ø80 p. 139



76015024
Insulated EPP slave Ø180
black p. 145



76050313
Ventilation collector insulated EPP,
2 connections Ø125 p. 140



76015013
Coupler XYZ insulated EPP
[4 x Ø150] p. 146



76015009
Tube insulated EPP Ø150,
1 meter black [slave included] p. 141



76015015
Set filterbox insulated EPP Ø150 p. 147



76015022
Tube insulated EPP Ø180,
1 meter black [slave included] p. 142



76050316
Outdoor control valve insulated EPP
Ø150 p. 148



76015010
Curve insulated EPP 90° Ø150
black [slave included] p. 143



76050314
Endcap insulated EPP Ø80 p. 149



76015023
Curve insulated EPP 90° Ø180
black [slave included] p. 144



76050315
Endcap insulated EPP Ø125/150 p. 149

TECHNICAL DATA SHEET:

Ventilation collector insulated EPP, 8 connections - 76050311

PRODUCT CHARACTERISTICS

- Inner diameter 150 mm
- Material EPP
- Δ (thermal conductivity) 0.039 [W/m.K]
- Airtightness class C



TECHNICAL DRAWINGS

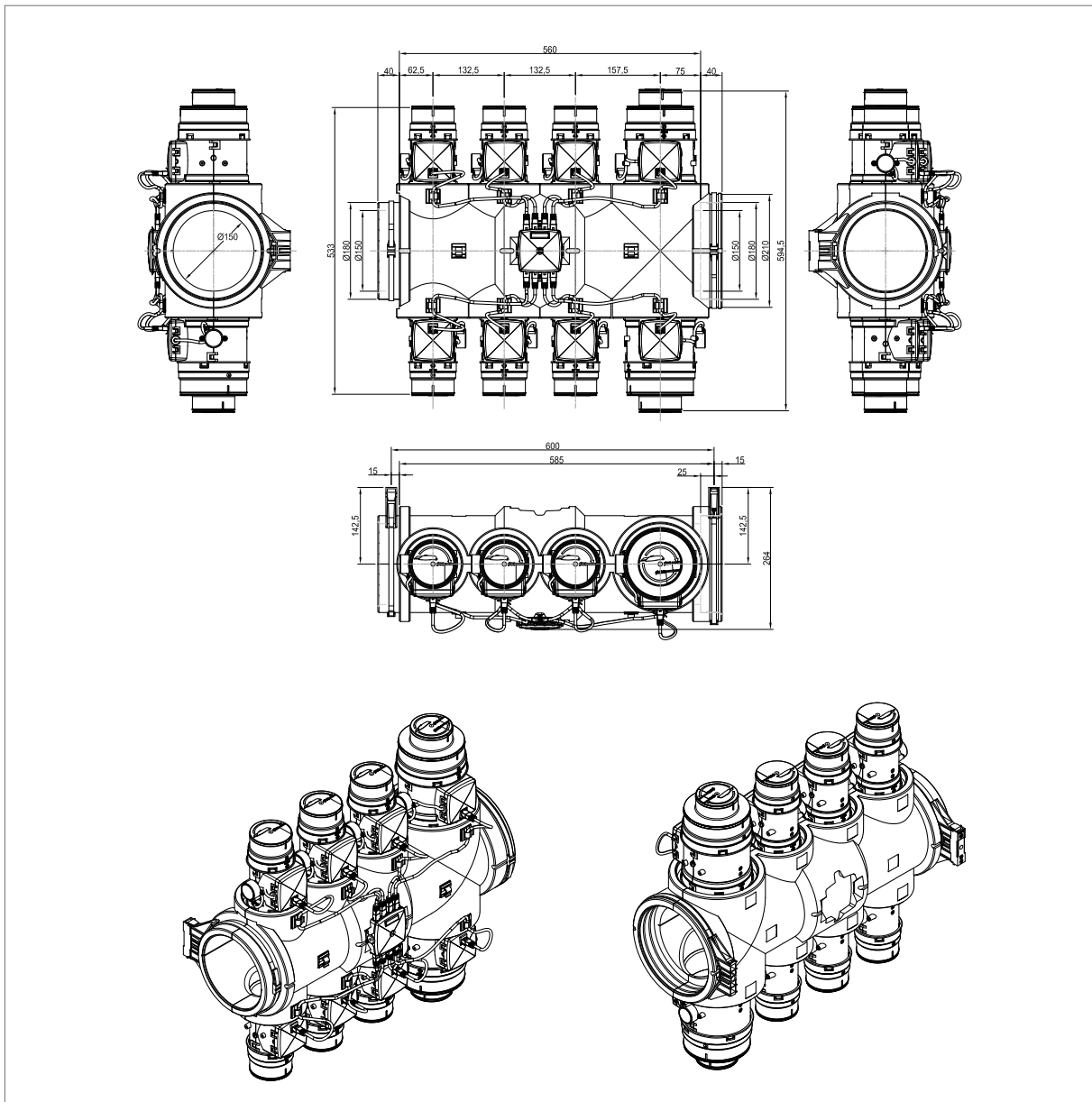

TECHNICAL DATA SHEET:

Ventilation collector insulated EPP, 2 connections Ø80 - 76050312

PRODUCT CHARACTERISTICS

- Inner diameter 150 mm
- Material EPP
- Δ (thermal conductivity) 0.039 [W/m.K]
- Airtightness class C



TECHNICAL DRAWINGS

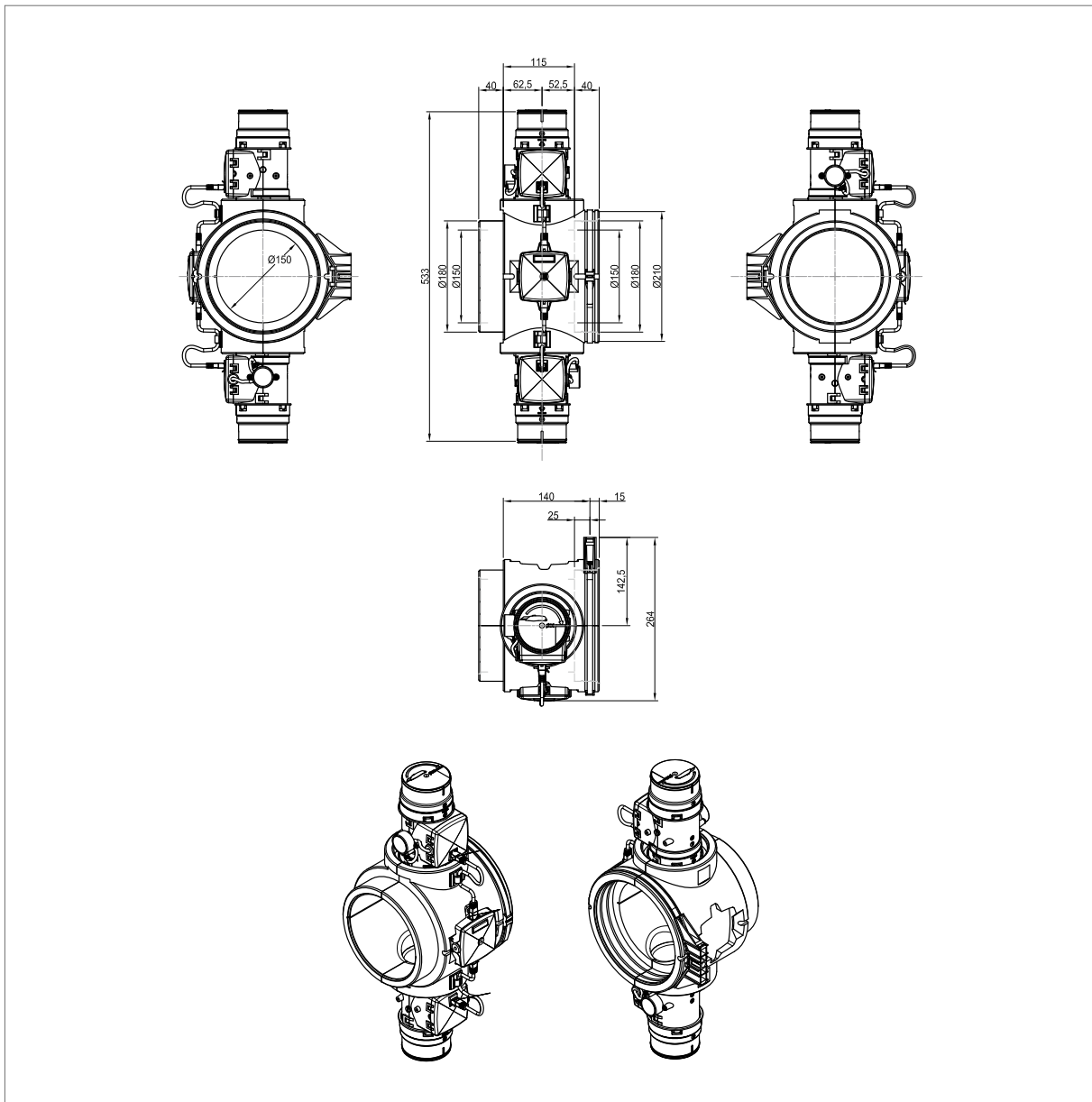

TECHNICAL DATA SHEET:

Ventilation collector insulated EPP, 2 connections $\text{\O}125$ - 76050313

PRODUCT CHARACTERISTICS

- Inner diameter 150 mm
- Material EPP
- Δ (thermal conductivity) 0.039 [W/m.K]
- Airtightness class C



TECHNICAL DRAWINGS

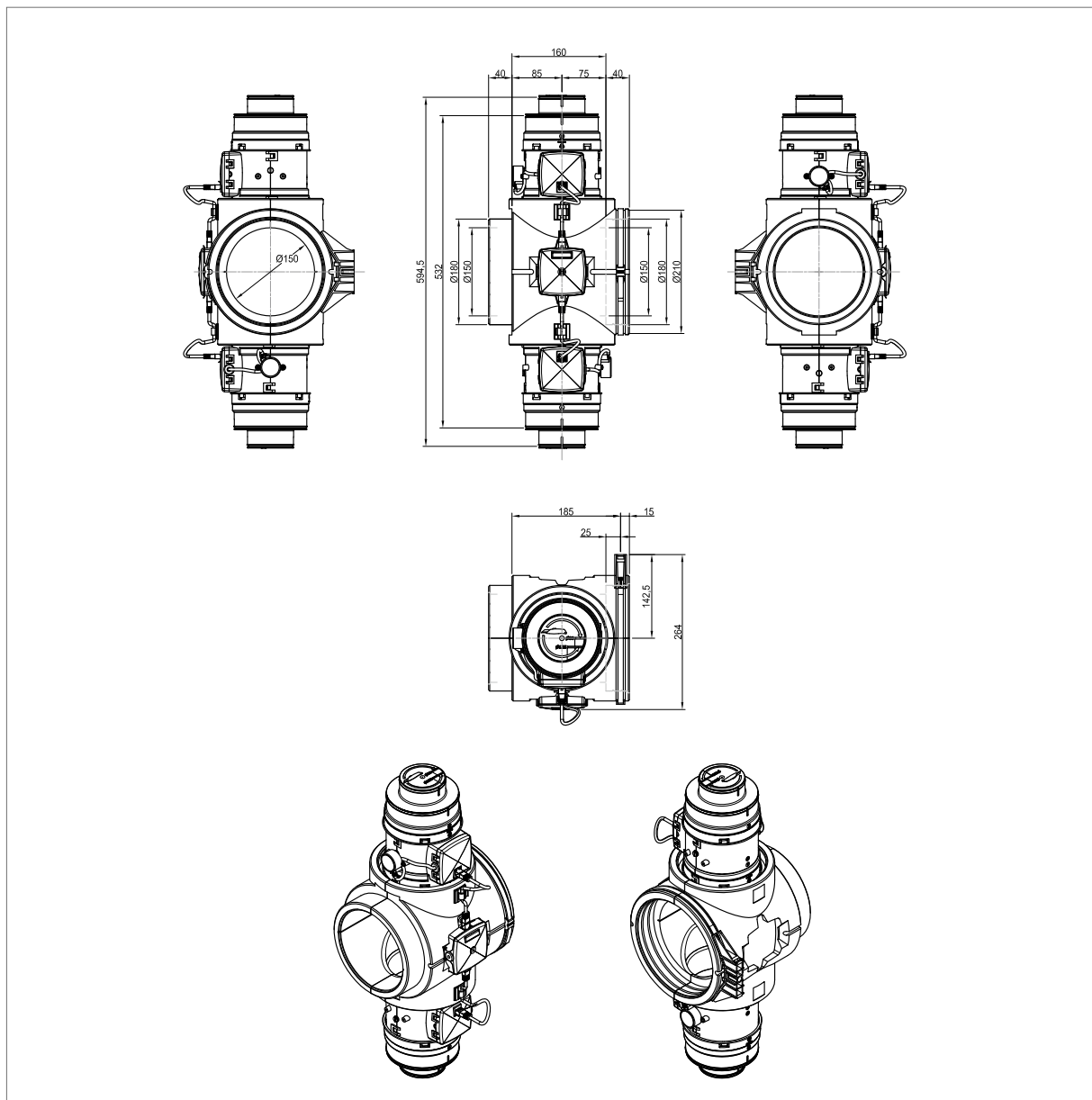

TECHNICAL DATA SHEET:

Tube insulated EPP Ø150 - 76015009

PRODUCT CHARACTERISTICS

- Inner diameter 150 mm
- Material EPP
- Δ [thermal conductivity] 0.039 [W/m.K]
- Airtightness class C

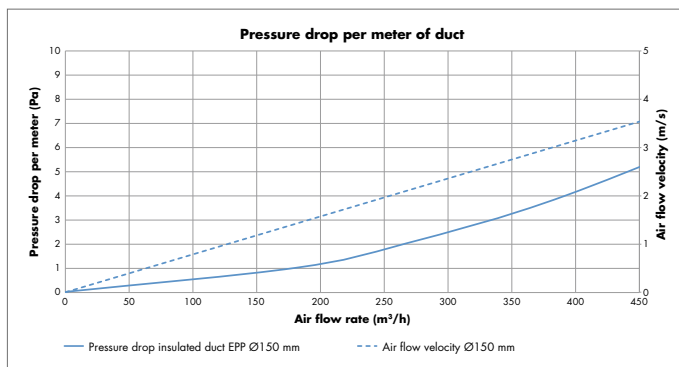

TECHNICAL DRAWINGS

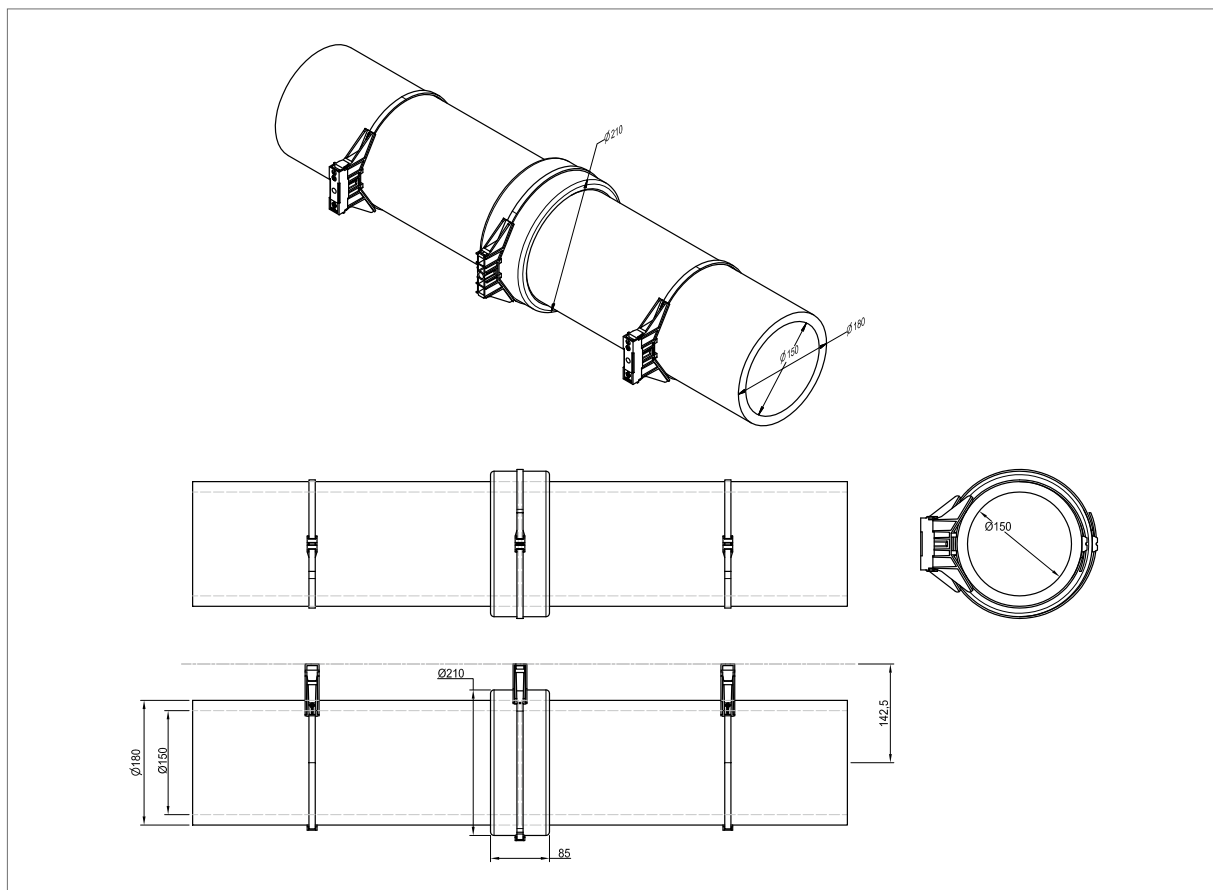

TECHNICAL DATA SHEET:

Tube insulated EPP Ø180 - 76015022

PRODUCT CHARACTERISTICS

- Inner diameter 180 mm
- Material EPP
- Δ [thermal conductivity] 0.039 [W/m.K]
- Airtightness class C

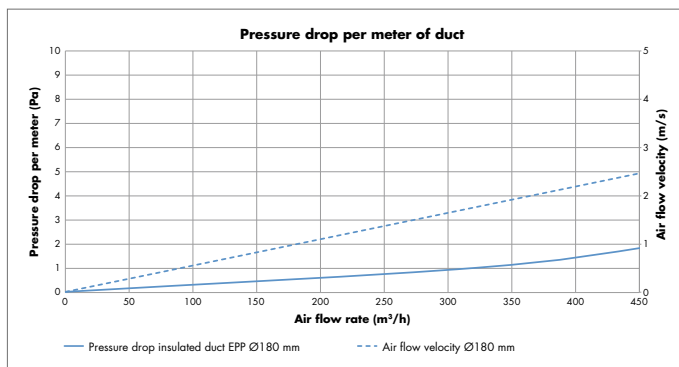

TECHNICAL DRAWINGS

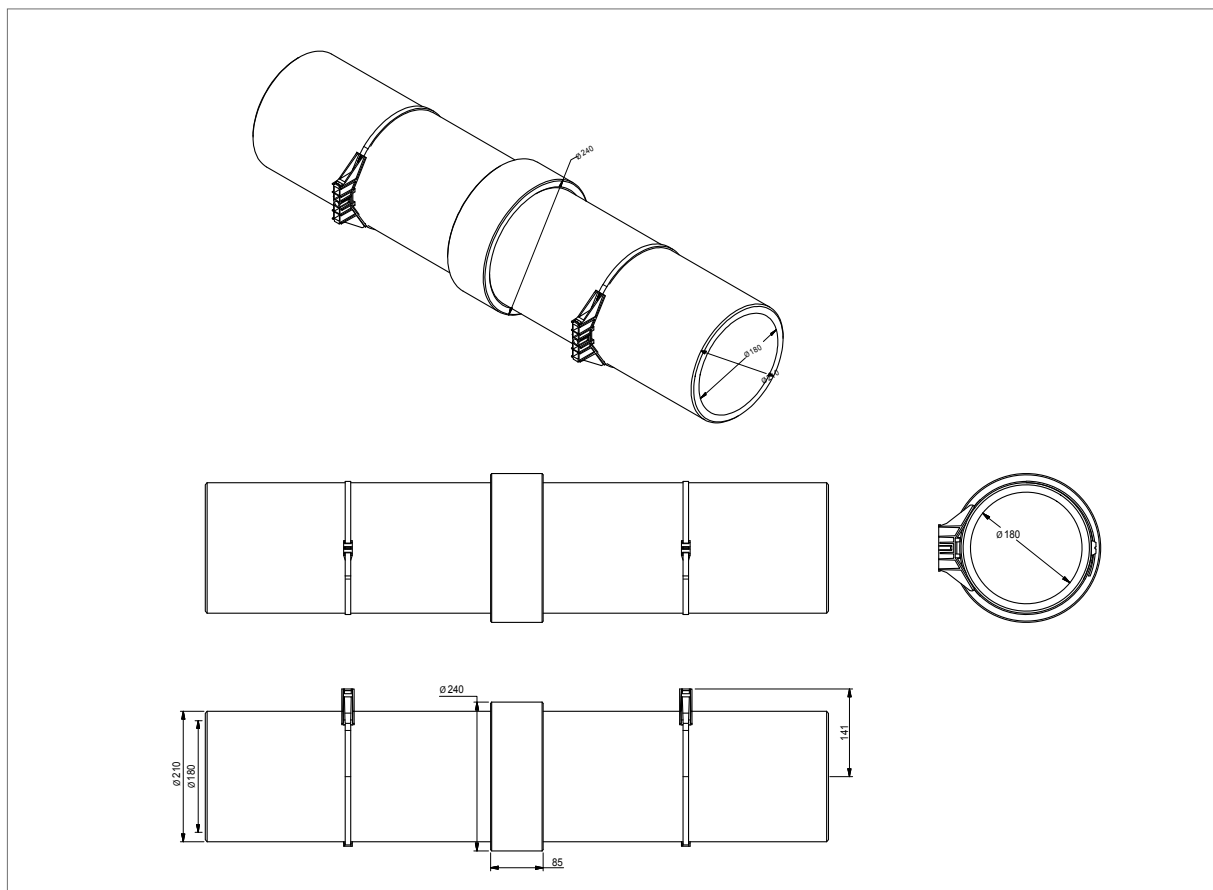

TECHNICAL DATA SHEET:

Curve insulated EPP 90° Ø150 - 76015010

PRODUCT CHARACTERISTICS

- Inner diameter 150 mm
- Material EPP
- Δ [thermal conductivity] 0.039 [W/m.K]
- Airtightness class C

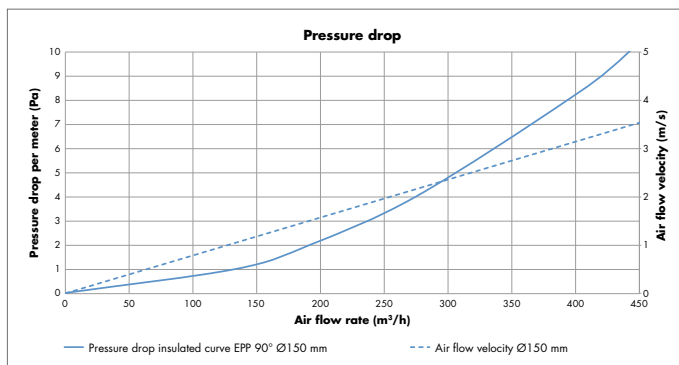

TECHNICAL DRAWINGS

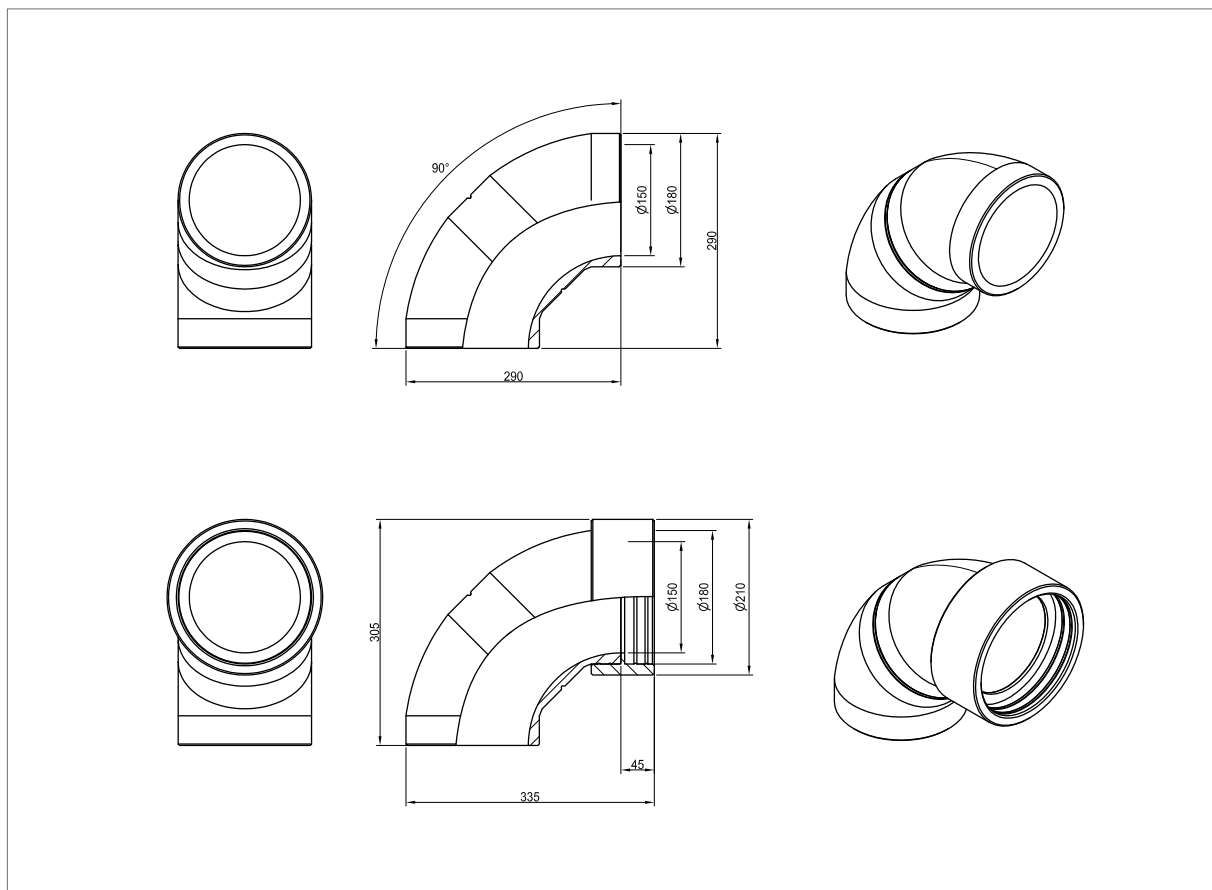

TECHNICAL DATA SHEET:

Curve insulated EPP 90° Ø180 - 76015023

PRODUCT CHARACTERISTICS

- Inner diameter 180 mm
- Material EPP
- Δ [thermal conductivity] 0.039 [W/m.K]
- Airtightness class C

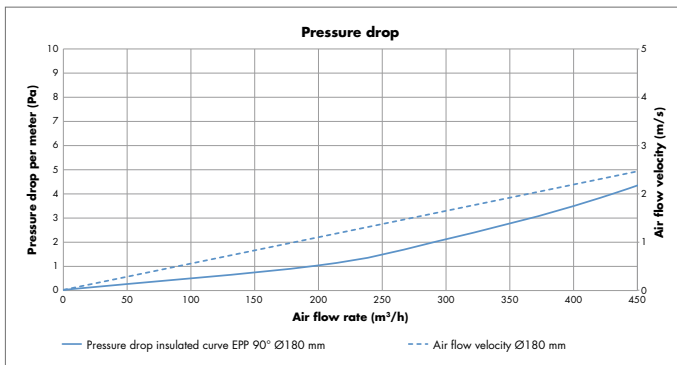

TECHNICAL DRAWINGS

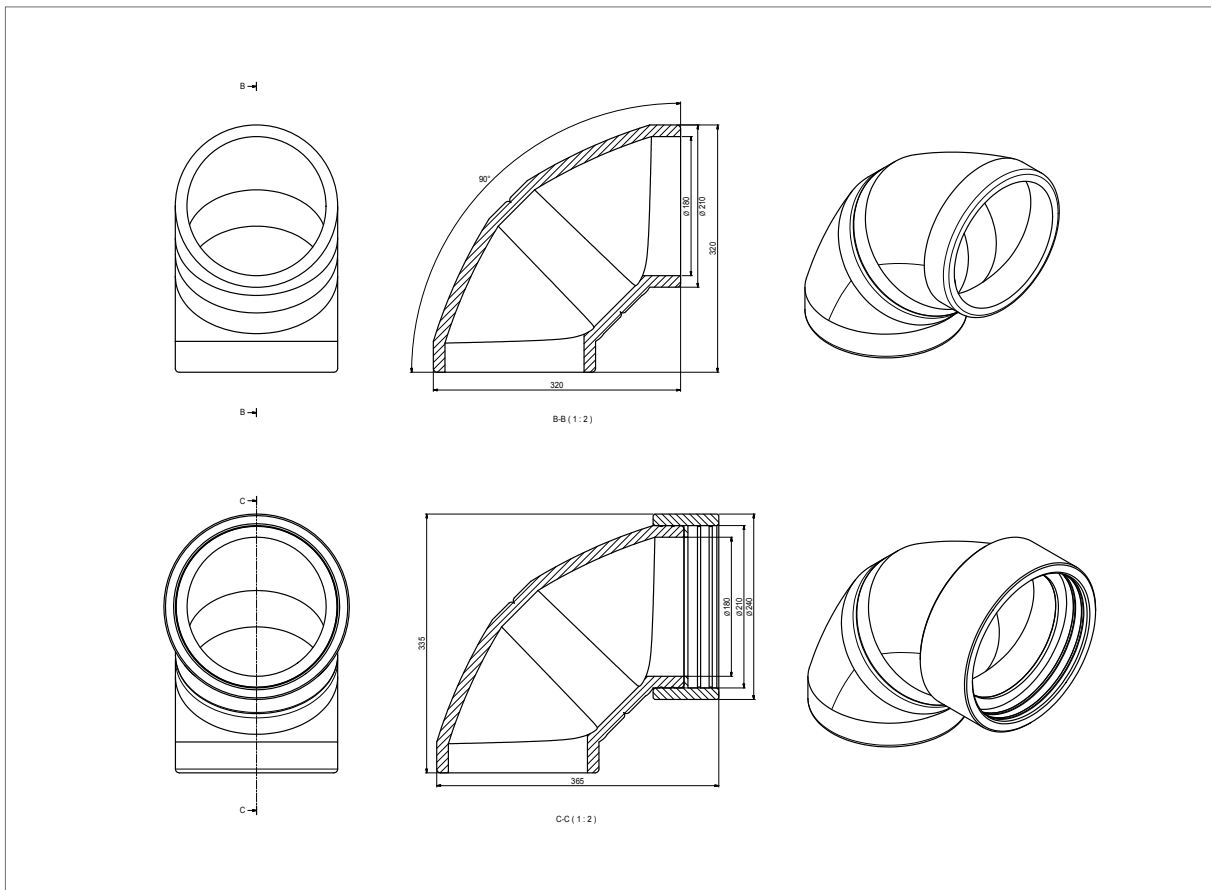

TECHNICAL DATA SHEET:

Insulated EPP slave Ø150 / Ø180 - 76015012 - 76015024

Insulated EPP slave Ø150 - 76015012

PRODUCT CHARACTERISTICS

- Inner diameter 150 mm
- Material EPP
- Δ [thermal conductivity] 0.039 [W/m.K]
- Airtightness class C



Insulated EPP slave Ø180 - 76015024

PRODUCT CHARACTERISTICS

- Inner diameter 180 mm
- Material EPP
- Δ [thermal conductivity] 0.039 [W/m.K]
- Airtightness class C

TECHNICAL DATA SHEET:

Coupler XYZ insulated EPP - 76015013

PRODUCT CHARACTERISTICS

- Inner diameter 150 mm
- Material EPP
- Δ [thermal conductivity] 0.039 [W/m.K]
- Airtightness class C



TECHNICAL DRAWINGS

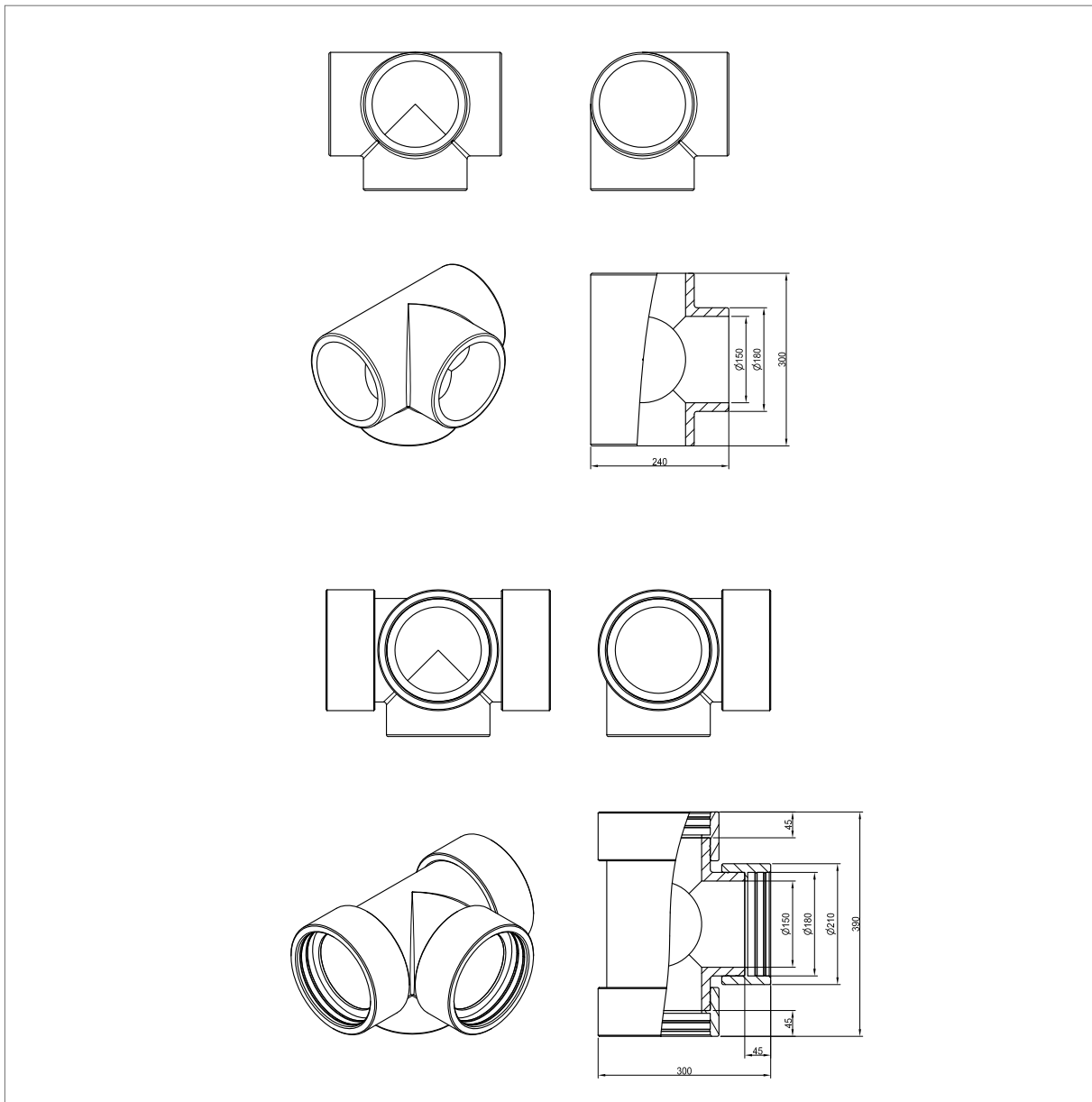

TECHNICAL DATA SHEET:

Set filterbox insulated EPP Ø150 - 76015015

PRODUCT CHARACTERISTICS

- Inner diameter 150 mm
- Material EPP
- Δ [thermal conductivity] 0.039 [W/m.K]
- Airtightness class C



TECHNICAL DRAWINGS

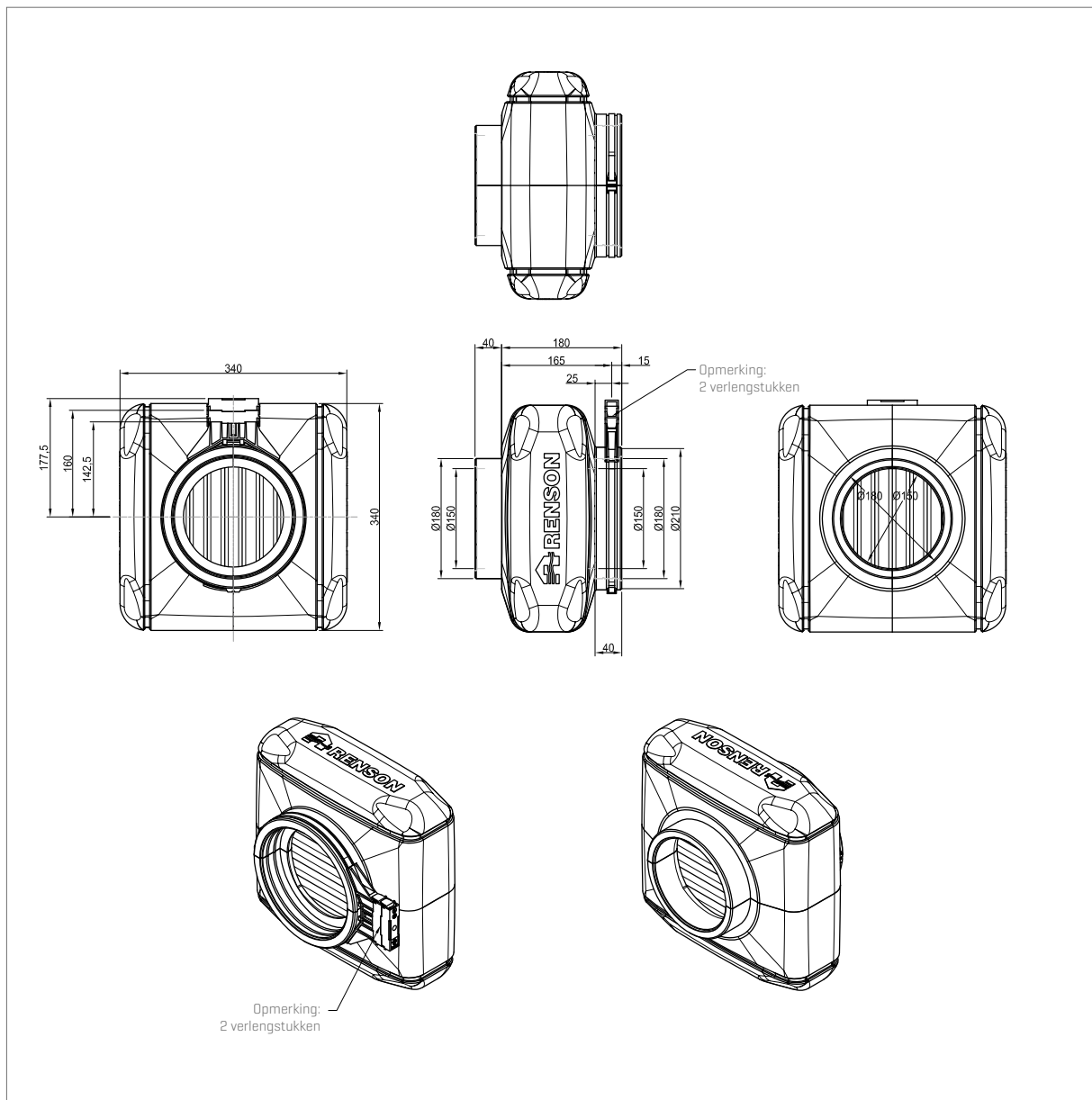

TECHNICAL DATA SHEET:

Outdoor control valve insulated EPP Ø150 - 76050316

PRODUCT CHARACTERISTICS

- Inner diameter 150 mm
- Material EPP
- Δ [thermal conductivity] 0.039 [W/m.K]
- Airtightness class C



TECHNICAL DRAWINGS

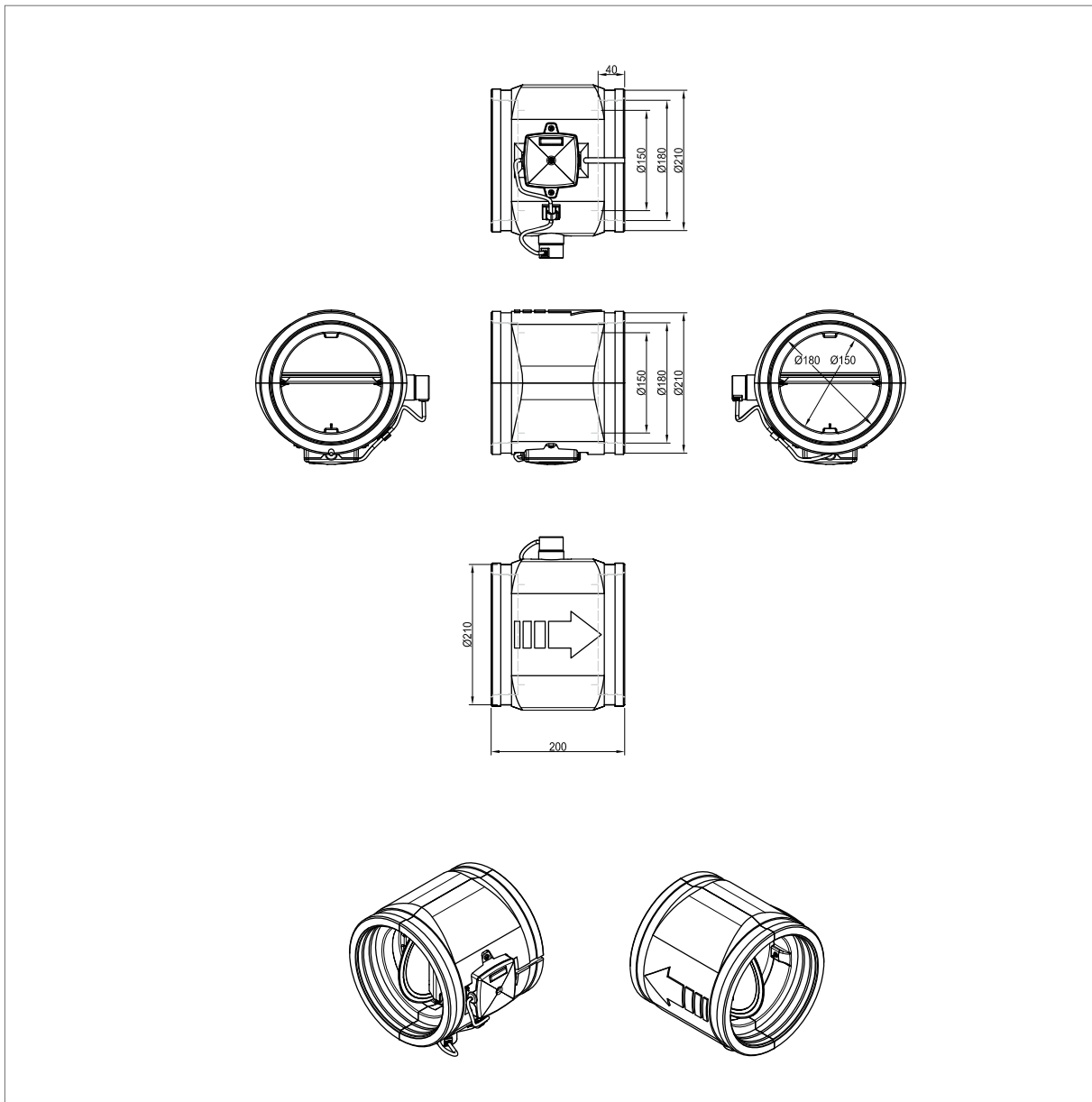

TECHNICAL DATA SHEET:

Endcap insulated EPP Ø80 / Ø125 / Ø150 - 76050314 - 76050315

Endcap insulated EPP Ø80 - 76050314

PRODUCT CHARACTERISTICS

- Inner diameter 80 mm
- Material EPP
- Δ [thermal conductivity] 0.039 [W/m.K]
- Airtightness class C





























Endcap insulated EPP Ø125/150 - 76050315

PRODUCT CHARACTERISTICS

- Inner diameter 125/150 mm
- Material EPP
- Δ [thermal conductivity] 0.039 [W/m.K]
- Airtightness class C

TECHNICAL DATA SHEET:

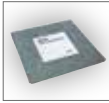
Overview Easyflex® ducts

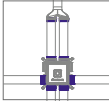
	G0013110 Flexible duct	p. 151
	G0013126 Flat oval duct	p. 152
	G0013139 Flexible connection piece	p. 153
	G0013111 Connector with integrated rubber gaskets, flat	p. 154
	G0013115 Fastening bracket	p. 155
	G0013112 Quick fastener	p. 156
	G0013137 Metal fastening bracket	p. 157
	G0013113 Horizontal bend 90°	p. 158
	G0013114 Vertical bend 90°	p. 159
	G0013120 Y-piece 2 x 140 x 60 mm > 140 x 60 mm	p. 160
	G0013130 Round duct Ø 125 mm	p. 161
	G0013122 Connector with integrated rubber gaskets, round Ø 125 mm	p. 162
	G0013117 Valve connection Ø 125 mm	p. 163
	G0013118 Double valve connection Ø 125 mm	p. 164
	G0013124 Adaptor flat to round 140 x 60 mm > Ø 125 mm	p. 165
	G0013141 Straight double adaptor 2 x 140 x 60 mm > Ø 125 mm	p. 166
	G0013131 Round duct Ø 80 mm	p. 167
	G0013121 Connector with integrated rubber gaskets, round Ø 80 mm	p. 168
	G0013116 Valve connection Ø 80 mm	p. 169
	G0013123 Adaptor flat to round 140 x 60 mm > Ø 80 mm	p. 170
	G0013145 Cross piece pivot	New! p. 171
	G0013135 Distribution box angled 160 mm	p. 172
	G0013136 Distribution box 8 connections	p. 173
	G0013140 Distribution box straight 160 mm	p. 174
	76050405 Inspection hatch	New! p. 175
	66031400 Insulation tube 140 x 60 x 13 mm	New! p. 176
	Easyflex® for multiple rooms	p. 177-178

TECHNICAL DATA SHEET:

Flexible duct - G0013110

DESCRIPTION

Easyflex® is a flexible polyethylene duct with an outer diameter of 140 x 64 mm and an equivalent inner diameter of 90 mm. The smooth inner wall of this double walled duct has an anti-static and antibacterial additive treatment to help prevent dust build-up and bacterial outbreaks.

The limited height of the Easyflex® air duct makes it easy to recess in screed, concrete or stud walls or false ceilings.

The air duct's broad cross section allows high air flow rates at low velocities, which leads to a quiet ventilation system operation.



Flexible duct - G0013110

PRODUCT CHARACTERISTICS

- Double walled
 - Ribbed outer sheath
 - Smooth inner sheath
- Made of polyethylene
 - Outer sheath: HDPE RAL 9002
 - Inner sheath: LDPE
- Antibacterial and anti-static
- Airtightness class D
- Smooth inner wall
 - Low air flow resistance
 - Easy to clean

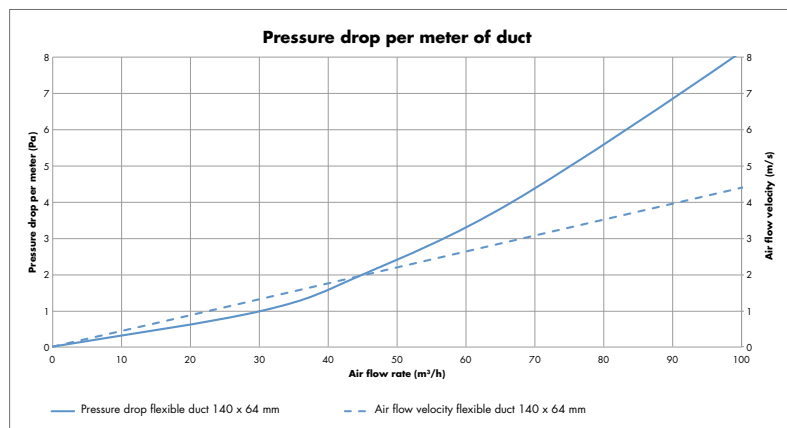

PACKAGING

Art. No.: G0013110
 Dimensions: 140 x 64 mm
 Roll length: 15 m
 Roll diameter: 1150 mm
 UV-protected: Wrapped in foil
 End caps: Every duct is carefully sealed with end caps

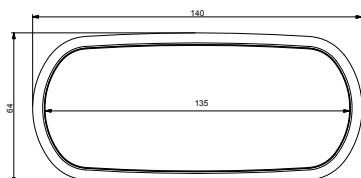

Type of duct	Flexible duct					
Air flow velocity [m/s]	0,50	1,00	1,50	2,00	2,50	3,00
Air flow rate [m³/h]	11,37	22,75	34,12	45,50	56,87	68,25
Duct length [m]	Pressure drop [Pa]					
1	0,18	0,6	1,23	2,04	3,02	4,17
2	0,36	1,20	2,46	4,08	6,05	8,33
3	0,53	1,81	3,69	6,12	9,07	12,50
4	0,71	2,41	4,92	8,16	12,09	16,67
5	0,89	3,01	6,15	10,20	15,11	20,83
6	1,07	3,61	7,38	12,24	18,14	25,00
7	1,24	4,22	8,61	14,29	21,16	29,17
8	1,42	4,82	9,84	16,33	24,18	33,34
9	1,60	5,42	11,07	18,37	27,21	37,50
10	1,78	6,02	12,30	20,41	30,23	41,67
11	1,96	6,63	13,53	22,45	33,25	45,84
12	2,13	7,23	14,76	24,49	36,27	50,00
13	2,31	7,83	15,99	26,53	39,30	54,17
14	2,49	8,43	17,22	28,57	42,32	58,34
15	2,67	9,03	18,45	30,61	45,34	62,50
16	2,84	9,64	19,68	32,65	48,37	66,67
17	3,02	10,24	20,91	34,69	51,39	70,84
18	3,20	10,84	22,14	36,73	54,41	75,01
19	3,38	11,44	23,37	38,77	57,43	79,17
20	3,56	12,05	24,60	40,82	60,46	83,34

TECHNICAL DATA SHEET:

Flat oval duct - G0013126

DESCRIPTION

The flat oval duct is made of PVC and has an outer diameter of 135 x 55 mm, and an equivalent inner diameter of 90 mm.

The limited height of the Easyflex® air duct makes it easy to recess in screed, concrete or stud walls or false ceilings.

The air duct's broad cross section allows high air flow rates at low velocities, which leads to quiet ventilation system operation.



Flat oval duct - G0013126

PRODUCT CHARACTERISTICS

- Made of PVC RAL 9002
- Anti-static
- Airtightness class D
- Smooth inner wall
 - Low air flow resistance
 - Easy to clean

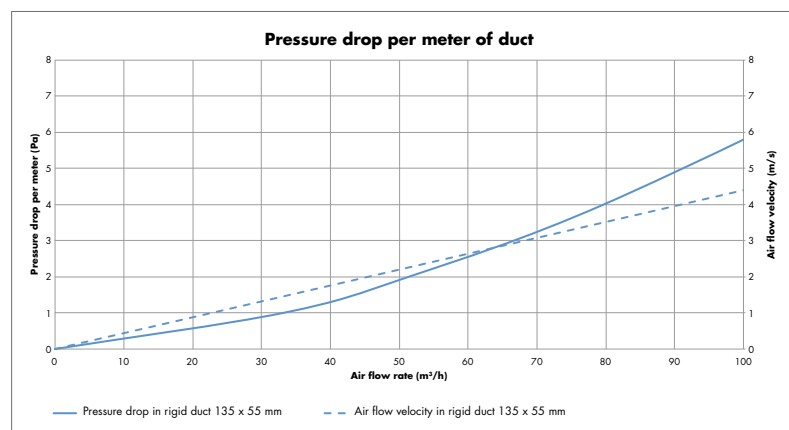

PACKAGING

Art. No.: G0013126
 Dimensions: 135 x 55 mm
 Length: 3 m
 UV-protected: Wrapped in foil
 End caps: Every duct is carefully sealed with end caps

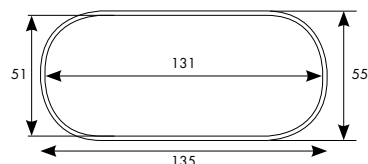

Type of duct	Flat oval duct 135 x 55 mm					
Air flow velocity [m/s]	0,50	1,00	1,50	2,00	2,50	3,00
Air flow rate [m³/h]	11,37	22,75	34,12	45,50	56,87	68,25
Duct length [m]	Pressure drop [Pa]					
1	0,18	0,55	1,05	1,65	2,35	3,13
2	0,37	1,10	2,10	3,30	4,70	6,26
3	0,55	1,66	3,14	4,95	7,04	9,39
4	0,74	2,21	4,19	6,60	9,39	12,53
5	0,92	2,76	5,24	8,25	11,74	15,66
6	1,11	3,31	6,29	9,90	14,09	18,79
7	1,29	3,87	7,33	11,55	16,43	21,92
8	1,48	4,42	8,38	13,20	18,78	25,05
9	1,66	4,97	9,43	14,85	21,13	28,18
10	1,85	5,52	10,48	16,50	23,48	31,31
11	2,03	6,08	11,53	18,16	25,83	34,44
12	2,22	6,63	12,57	19,81	28,17	37,58
13	2,40	7,18	13,62	21,46	30,52	40,71
14	2,59	7,73	14,67	23,11	32,87	43,84
15	2,77	8,28	15,72	24,76	35,22	46,97
16	2,96	8,84	16,76	26,41	37,57	50,10
17	3,14	9,39	17,81	28,06	39,91	53,23
18	3,33	9,94	18,86	29,71	42,26	56,36
19	3,51	10,49	19,91	31,36	44,61	59,49
20	3,70	11,05	20,96	33,01	46,96	62,63

TECHNICAL DATA SHEET:

Flexible connection piece - G0013139

DESCRIPTION

The Easyflex® connection piece can be used to connect flat oval ducts [G0013126] and flexible ducts [G0013110].

The connection piece consists of a 350 mm flexible air duct with a connection sleeve with rubber along both sides. It can also be used for horizontal and vertical curves of 90° at the most, but as well for other difficult obstacle points [for instance S-curves].

The flexible connection piece has an outer diameter of 140 x 64 mm and an equivalent inner diameter of 90 mm.

The air duct's broad cross section allows high air flow rates at low velocities, which leads to a quiet ventilation system operation.

The limited height of the Easyflex® connection piece makes it easy to recess in stud walls or false ceilings. It can also be poured in screed or concrete as long as strengthening or reinforcement is provided.

The smooth finished inner wall has an anti-static additive treatment to help prevent dust build-up and bacterial outbreaks.



Flexible connection piece - G0013139

PRODUCT CHARACTERISTICS

- Single walled
 - Ribbed out sheath
- Made of polyethylene
 - HDPE RAL 9002
- Anti-static
- Airtightness class D
[as long as tape is used]
- Smooth inner wall

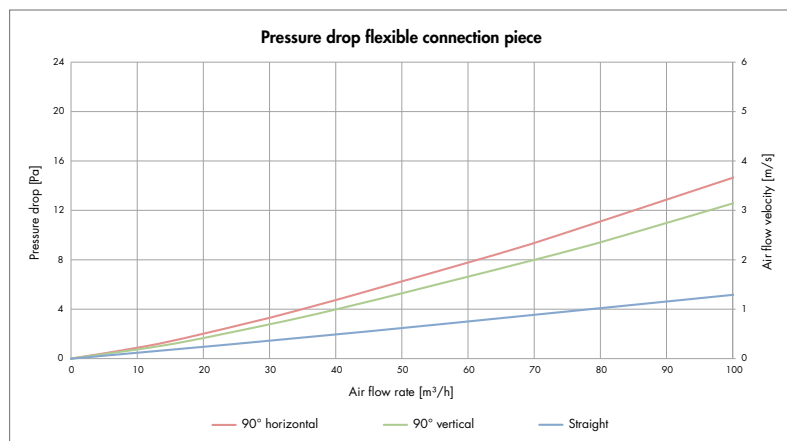

PACKAGING

Art. No.: G0013139
 Dimensions: 140 x 64 x 420 mm
 Packaging: 12 pieces per box

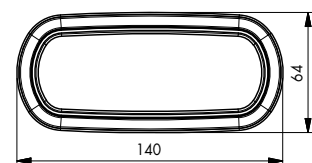
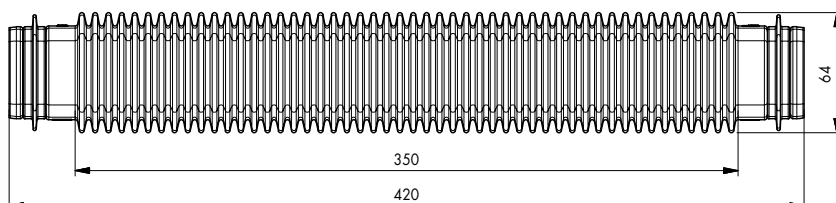

TECHNICAL DATA SHEET:

Connector with integrated rubber gaskets, flat - G0013111

DESCRIPTION

The unique coupling system ensures an almost perfect airtightness. The connector is equipped with two integrated double rubber seals.

Thanks to these seals, the Easyflex® air duct system qualifies for airtightness class D, meaning the system is three times less liable to leak than class C.

The flat connector can be used to couple:

- The Easyflex® flexible duct [G0013110]
- The Easyflex® flat oval duct [G0013126]
- Coupling of all Easyflex® accessories

The coupling can be reinforced with:

- Quick fastener [G0013112]
- Metal fastening bracket [G0013137]



Connector with integrated rubber gaskets, flat - G0013111

PRODUCT CHARACTERISTICS

- Made of polypropylene
- Rubber sealing: TPE [ThermoPlastic Elastomer]
- Airtightness class D
- Smooth inner wall
 - Low air flow resistance
 - Easy to clean

PACKAGING

Art. No.: G0013111
Dimensions: 138,5 x 68,5 x 60,4 mm
Packaging: 50 pieces per box

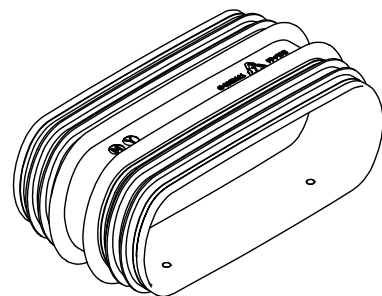
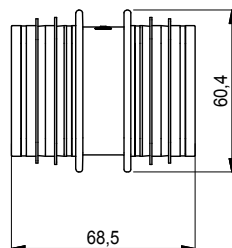
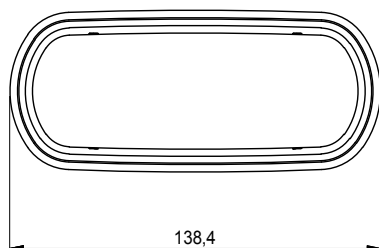

TECHNICAL DATA SHEET:

Fastening bracket - G0013115

DESCRIPTION

This fastening bracket can be used for all fixings of the Easyflex® range. Screws or pins can be used for claspings.

The components that can be fastened with this bracket are the following:

- The Easyflex® flexible duct [G0013110]
- The Easyflex® flat oval duct [G0013126]

PRODUCT CHARACTERISTICS

- Made of polypropylene
- Pre-formed mounting

PACKAGING

Art. No.: G0013115
Dimensions: 200 x 66 x 37 mm
Packaging: 200 pieces per box



Fastening bracket - G0013115

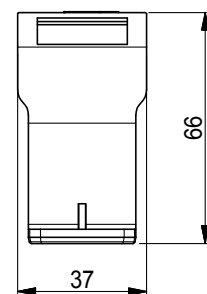
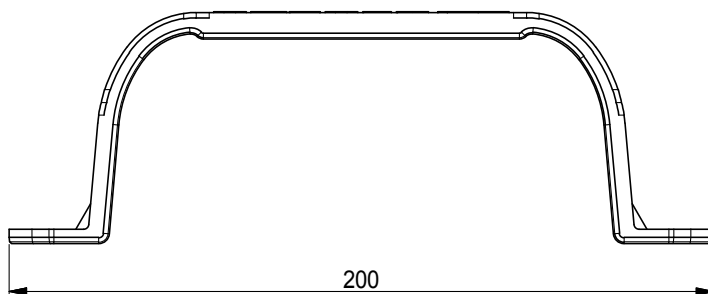

TECHNICAL DATA SHEET:

Quick fastener - G0013112

DESCRIPTION

These quick fasteners are used for all fixings of the Easyflex® range; always to be used in pairs. The fastening can be done using screws or concrete pins.

The fastening with clips makes overhand mounting much easier. The first quick fasteners can first be screwed to the ceiling, then the flexible can be easily clipped without tools.

The components that can be fastened with these quick couplings are the following:

- The Easyflex® flexible duct [G0013110]
- The Easyflex® flat oval duct [G0013126]
- Coupling of all Easyflex® accessories



Quick fastener - G0013112

PRODUCT CHARACTERISTICS

- Made of polypropylene
- Pre-formed mounting
- Fastening with clips that can be reopened

PACKAGING

Art. No.: G0013112
Dimensions: 179 x 58 x 48 mm
Packaging: 100 pieces per box

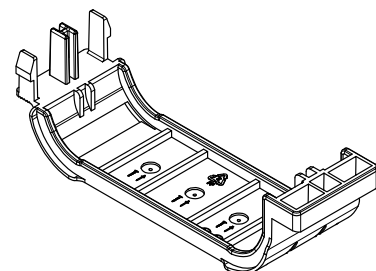
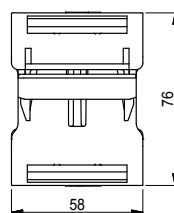
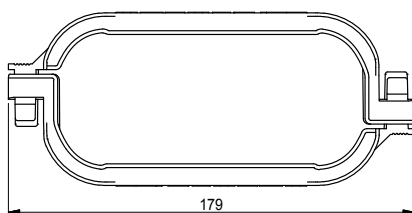

TECHNICAL DATA SHEET:

Metal fastening bracket - G0013137

DESCRIPTION

This fastening bracket can be used for all fixings of the Easyflex® range. Screws or pins can be used for clasping.

The components that can be fastened with this bracket are the following:

- The Easyflex® flexible duct [G0013110]
- The Easyflex® flat oval duct [G0013126]
- Fastening of all Easyflex® accessories
- Coupling with all distribution boxes



PRODUCT CHARACTERISTICS

- Made of chromed steel
- 63 x 48 x 188 mm

PACKAGING

Art. No.: G0013137
Dimensions: 175 x 205 x 159 mm
Packaging: 100 pieces per box

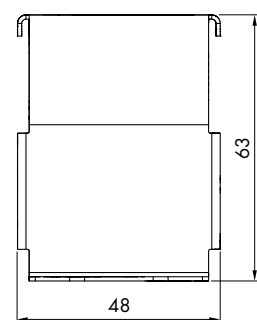
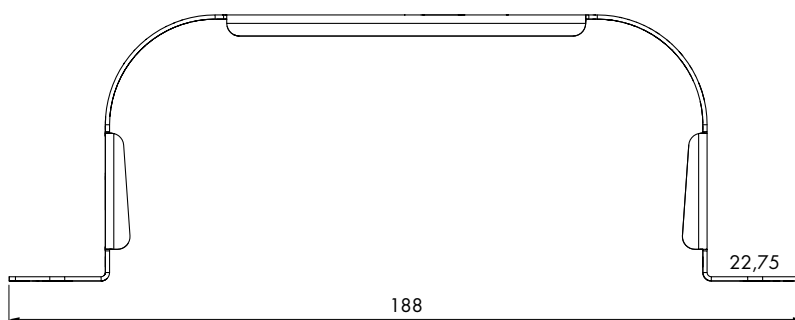

TECHNICAL DATA SHEET:

Horizontal bend 90° - G0013113

DESCRIPTION

It is best to avoid using flexible ducts for sharp bends. It is better to use fixed bend accessories, such as a 90° horizontal bend. The bend has integrated mounting bases to fix it to the supporting structure.



Horizontal bend 90° - G0013113

PRODUCT CHARACTERISTICS

- Made of polypropylene RAL 9002
- Anti-static and antibacterial
- Airtightness class D
- Smooth inner wall
 - Low air flow resistance
 - Easy to clean

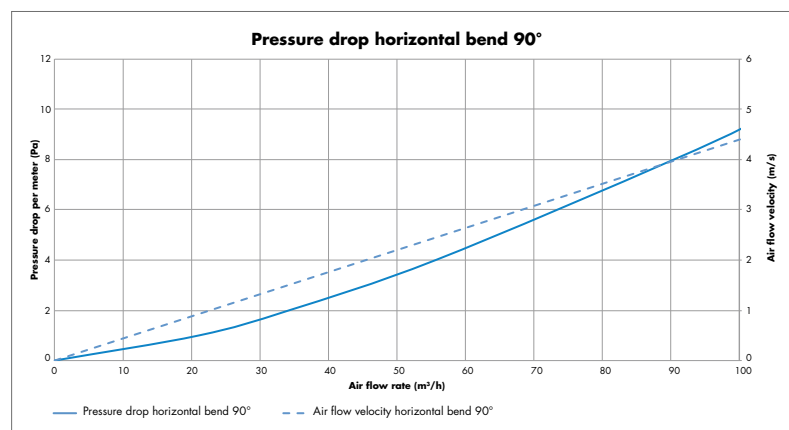

PACKAGING

Art. No.: G0013113
 Dimensions: 200 x 200 x 68 mm
 Packaging: 20 pieces per box

Type of accessory	Horizontal bend 90°		
Air flow rate [m³/h]	25	50	75
Air flow velocity [m/s]	1,10	2,20	3,30
Pressure drop [Pa]	1,27	3,43	6,12

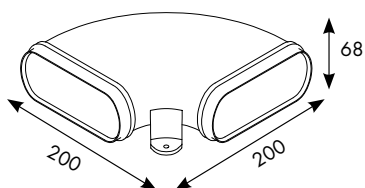

TECHNICAL DATA SHEET:

Vertical bend 90° - G0013114

DESCRIPTION

It is best to avoid using flexible duct for sharp bends. It is better to use fixed bend accessories, such as a 90° vertical bend.



Vertical bend 90° - G0013114

PRODUCT CHARACTERISTICS

- Made of polypropylene RAL 9002
- Anti-static and antibacterial
- Airtightness class D
- Smooth inner wall
 - Low air flow resistance
 - Easy to clean

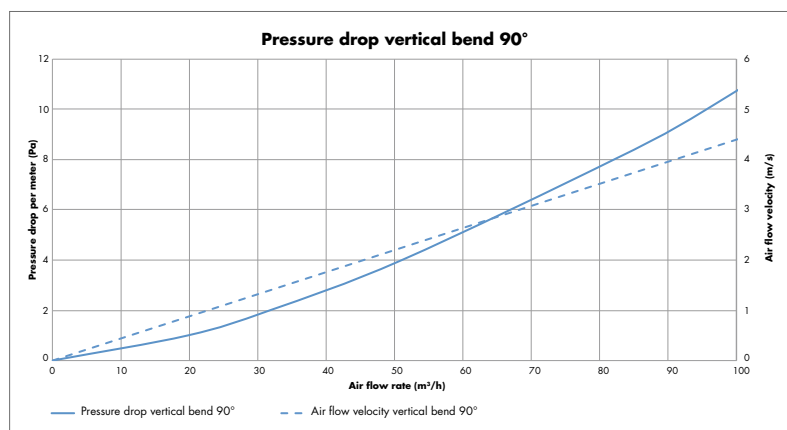

PACKAGING

Art. No.: G0013114
 Dimensions: 96 x 96 x 140 mm
 Packaging: 20 pieces per box

Type of accessory	Vertical bend 90°		
Air flow rate [m³/h]	25	50	75
Air flow velocity [m/s]	1,10	2,20	3,30
Pressure drop [Pa]	11	3,88	7,01

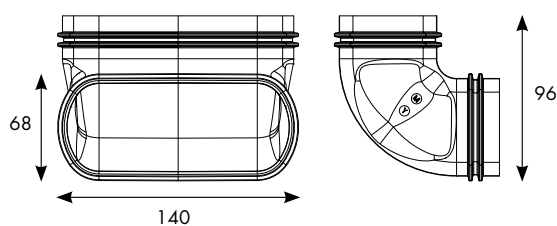

TECHNICAL DATA SHEET:

Y-piece - G0013120

DESCRIPTION

It is possible to connect one flat, oval channel to two flat, oval channels. In this way, two spaces can be reached with a single main channel.

For example, extraction from two rooms can be done on one valve. To do this, controllable grate bases must be installed to adjust the flow rates.



Y-piece - 2x140x60 mm > 140x60 mm
G0013120

PRODUCT CHARACTERISTICS

- Made of PVC RAL 9002
- Anti-static and antibacterial
- Airtightness class D
- Smooth inner wall
 - Low air flow resistance
 - Easy to clean

PACKAGING

Art. No.: G0013120
Dimensions: 300 x 282 x 62 mm
Packaging: 12 pieces per box

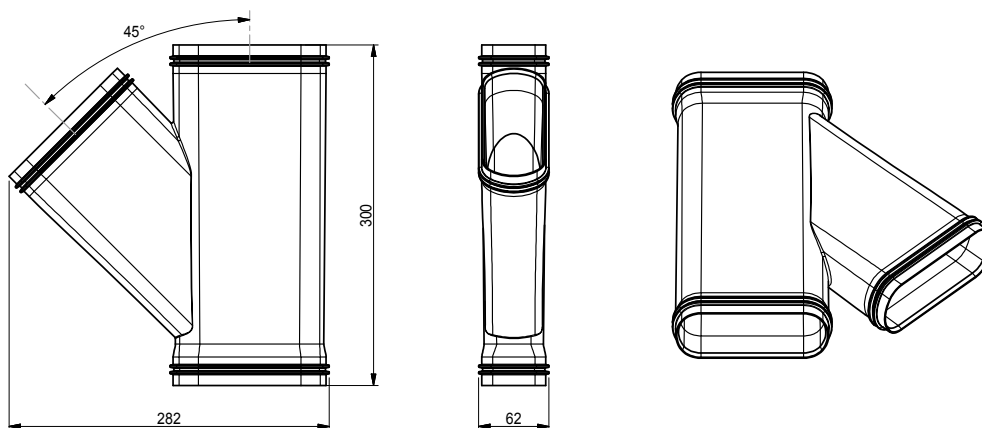
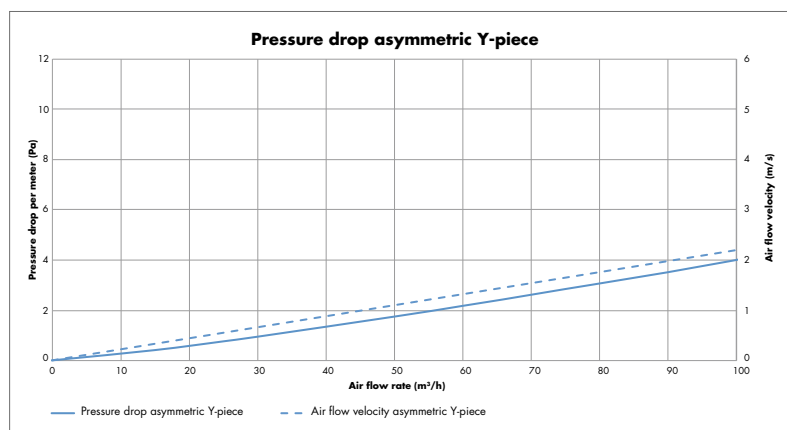

TECHNICAL DATA SHEET:

Round duct \varnothing 125 mm - G0013130

DESCRIPTION

Round ducts are usually used on vertical lengths up to the ventilation system. We recommend a 125 mm diameter for spaces with an air flow rate of $> 50 \text{ m}^3/\text{h}$.

The 125 mm round duct is characterized by its very low pressure drop. High air flow rates are achievable at low air flow velocities.

The length of the concrete duct [G0013132] is 25 cm.



Round duct \varnothing 125 mm - G0013130

PRODUCT CHARACTERISTICS

- Made of PVC RAL 9002
- Anti-static
- Airtightness class D
- Smooth inner wall
 - Low air flow resistance
 - Easy to clean

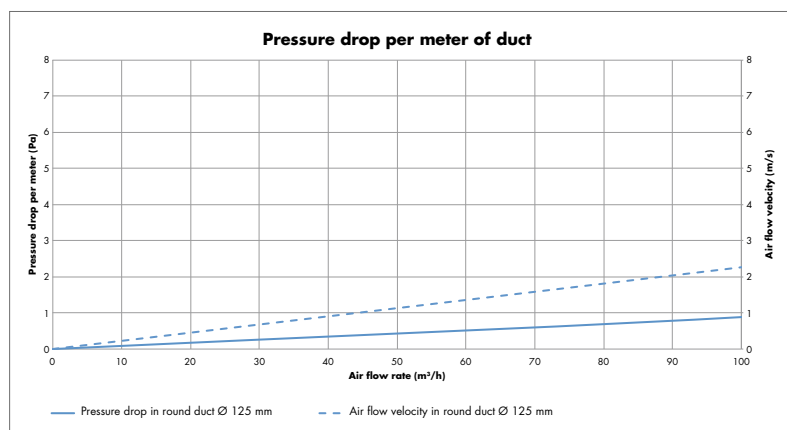

PACKAGING

Art. No.: G0013130
 Diameter: 125 mm
 Length: 3 m
 UV-protected: Wrapped in foil
 End caps: Every duct is carefully sealed with end caps

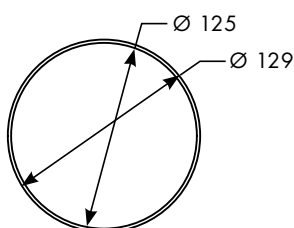

Type of duct	Round duct \varnothing 125 mm					
Air flow velocity [m/s]	0,50	1,00	1,50	2,00	2,50	3,00
Air flow rate [m ³ /h]	22,09	44,2	66,34	88,4	110,4	132,5
Duct length [m]	Pressure drop [Pa]					
1	0,06	0,21	0,42	0,68	1,00	1,37
2	0,13	0,42	0,84	1,37	2,00	2,73
3	0,19	0,63	1,26	2,05	3,00	4,10
4	0,26	0,84	1,67	2,74	4,01	5,47
5	0,32	1,05	2,09	3,42	5,01	6,84
6	0,39	1,26	2,51	4,11	6,01	8,20
7	0,45	1,47	2,93	4,79	7,01	9,57
8	0,51	1,68	3,35	5,47	8,01	10,94
9	0,58	1,89	3,77	6,16	9,01	12,31
10	0,64	2,10	4,19	6,84	10,02	13,67
11	0,71	2,31	4,61	7,53	11,02	15,04
12	0,77	2,51	5,02	8,21	12,02	16,41
13	0,83	2,72	5,44	8,90	13,02	17,78
14	0,90	2,93	5,86	9,58	14,02	19,14
15	0,96	3,14	6,28	10,26	15,02	20,51
16	1,03	3,35	6,70	10,95	16,03	21,88
17	1,09	3,56	7,12	11,63	17,03	23,25
18	1,16	3,77	7,54	12,32	18,03	24,61
19	1,22	3,98	7,96	13,00	19,03	25,98
20	1,28	4,19	8,37	13,69	20,03	27,35

TECHNICAL DATA SHEET:

Connector with integrated rubber gaskets, round \varnothing 125 mm - G0013122

DESCRIPTION

The unique coupling system ensures an almost perfect airtightness. The connector is equipped with two integrated double rubber seals.

Thanks to these seals, the Easyflex® air duct system qualifies for airtightness class D, meaning the system is three times less liable to leak than class C.

The round connector \varnothing 125 mm can be used to couple:

- Round duct \varnothing 125 mm
- Concrete duct \varnothing 125 mm
- All accessories \varnothing 125 mm.

The coupling can be reinforced with PVC tape [66014115].



Connector with integrated rubber gaskets, round \varnothing 125 mm - G0013122

PRODUCT CHARACTERISTICS

- Made of polypropylene
- Rubber sealing: TPE [ThermoPlastic Elastomer]
- Airtightness class D
- Smooth inner wall
 - Low air flow resistance
 - Easy to clean

PACKAGING

Art. No.: G0013122
Dimensions: 125 x 62,5 mm
Packaging: 50 pieces per box

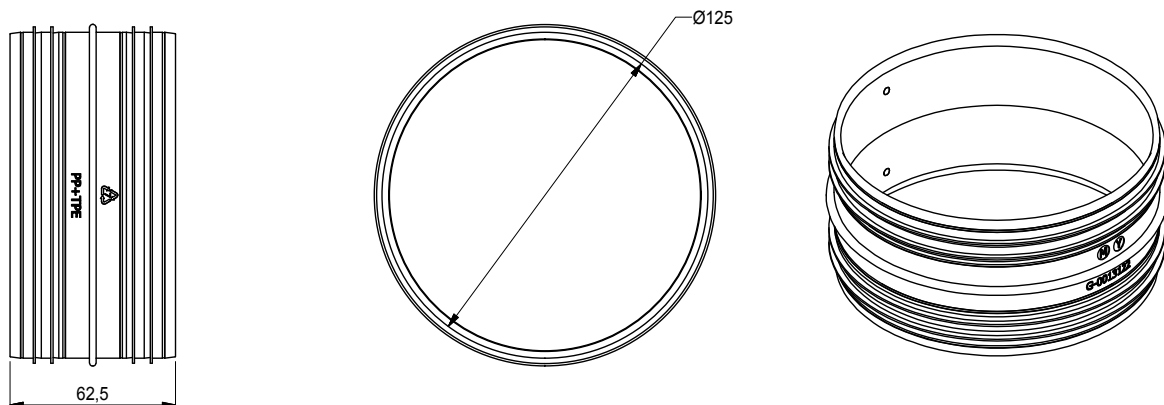

TECHNICAL DATA SHEET:

Valve connection \varnothing 125 mm - G0013117

DESCRIPTION

You can make seamless connections between RENSON® design extraction louvres or SQair valves and valve connectors in an Easyflex® air duct system. Valve connectors come in two diameters: \varnothing 80 mm in-line connectors for spaces with an extraction air flow rate $\leq 50 \text{ m}^3/\text{h}$ and \varnothing 125 mm for spaces with an extraction air flow rate $\geq 50 \text{ m}^3/\text{h}$.

You can connect extraction grills directly to the valve transits, if they are built into a Gyproc wall. If the extraction louver is fitted in a vaulted surface, you can use a connector that you can saw along its length.

You can also use valve connectors as a connecting piece to join flat, oval ducts to round ducts.



Valve connection \varnothing 125 mm - G0013117

PRODUCT CHARACTERISTICS

- Made of polypropylene RAL 9002
- Anti-static and antibacterial
- Airtightness class D
- Smooth inner wall
 - Low air flow resistance
 - Easy to clean

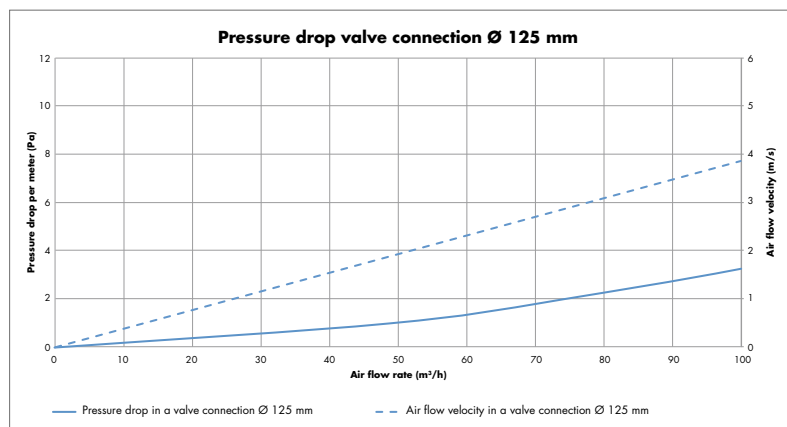

PACKAGING

Art. No.: G0013117
 Dimensions: 170 x 140 x 114 mm
 Packaging: 20 pieces per box

Type of accessory	Valve connection \varnothing 125 mm		
Air flow rate [m^3/h]	25	50	75
Air flow velocity [m/s]	0,83	1,67	2,50
Pressure drop [Pa]	0,33	1,05	2,05

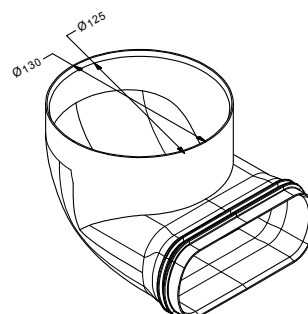
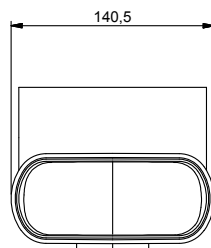
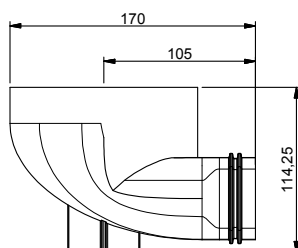

TECHNICAL DATA SHEET:

Double valve connection \varnothing 125 mm - G0013118

DESCRIPTION

You can make seamless connections between RENSON® design extraction louvres and valve connectors in an Easyflex® air duct system. Double valve connectors are used for spaces requiring high air flow rates.

You can connect extraction grills directly to the valve transits, if they are built into a Gyproc wall. If the extraction louver is fitted in a vaulted structure, you use a connecting piece that can be sawn in its length.

You can also use a double valve connection as a connecting piece to join flat, oval ducts to round ducts.



Double valve connection \varnothing 125 mm - G0013118

PRODUCT CHARACTERISTICS

- Made of polypropylene RAL 9002
- Anti-static and antibacterial
- Airtightness class D
- Smooth inner wall
 - Low air flow resistance
 - Easy to clean

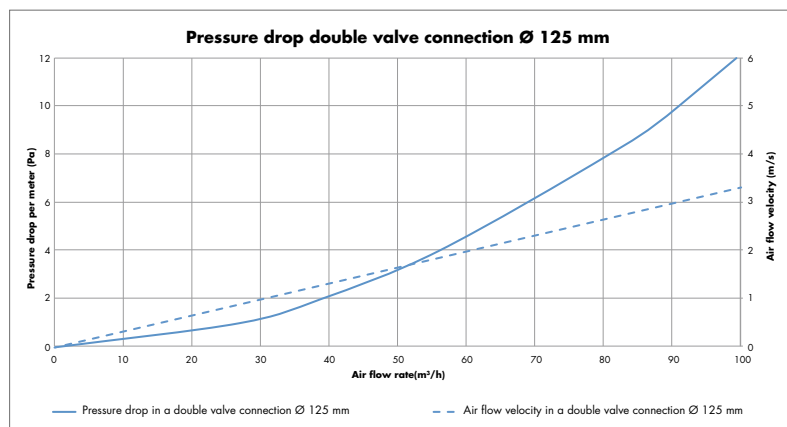

PACKAGING

Art. No.: G0013118
 Dimensions: 200 x 325 x 114 mm
 Packaging: 10 pieces per box

Type of accessory	Double valve connection \varnothing 125 mm		
Air flow rate [m³/h]	25	50	75
Air flow velocity [m/s]	0,97	1,93	2,90
Pressure drop [Pa]	0,87	3,23	6,94

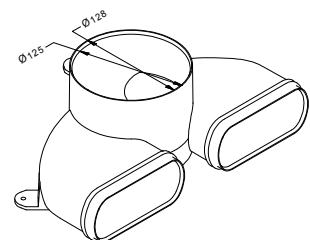
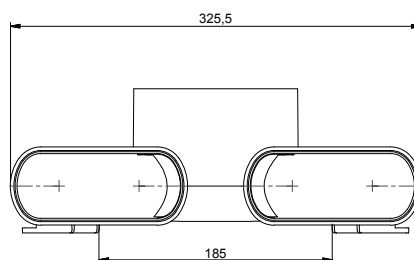
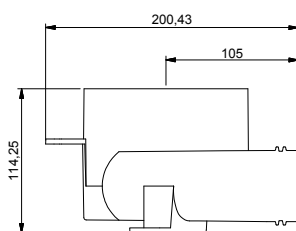

TECHNICAL DATA SHEET:

Adaptor flat to round - G0013124

DESCRIPTION

You can make a transition connection between the oval and round duct by using an in-line connector. You can use $\varnothing 80$ mm in-line connectors for spaces with an extraction air flow rate ≤ 50 m³/h and $\varnothing 125$ mm for spaces with an extraction air flow rate ≥ 50 m³/h.

You can connect extraction grills directly to in-line connectors, if they are built into a Gyproc wall.

And you can use in-line connectors to join flat, oval ducts to round ducts.



Adaptor flat to round
140 x 60 mm > $\varnothing 125$ mm - G0013124

PRODUCT CHARACTERISTICS

- Made of polypropylene RAL 9002
- Anti-static and antibacterial
- Airtightness class D
- Smooth inner wall
 - Low air flow resistance
 - Easy to clean

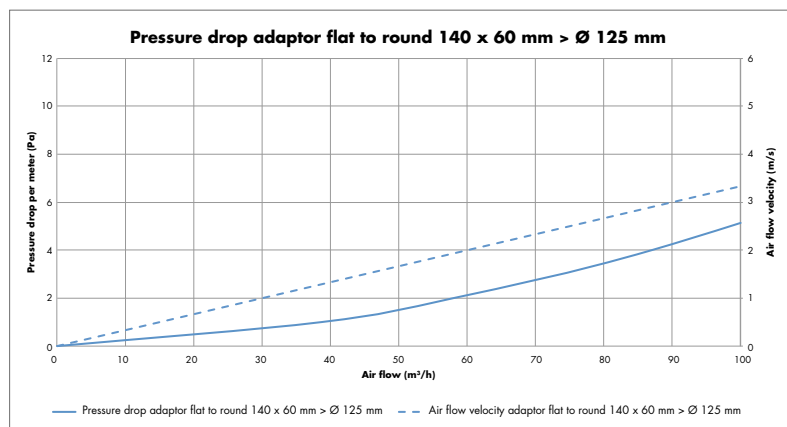

PACKAGING

Art. No.: G0013124
Dimensions: 155 x 185 x 139 mm
Packaging: 20 pieces per box

Type of accessory	Adaptor flat to round $\varnothing 125$ mm		
Air flow rate [m ³ /h]	25	50	75
Air flow velocity [m/s]	0,83	1,67	2,50
Pressure drop [Pa]	0,48	1,55	3,10

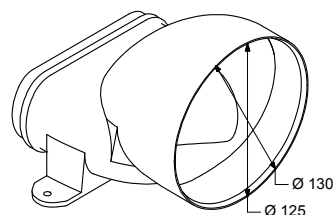
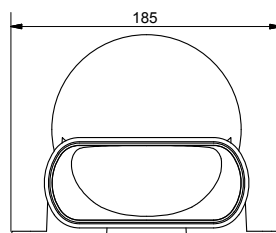
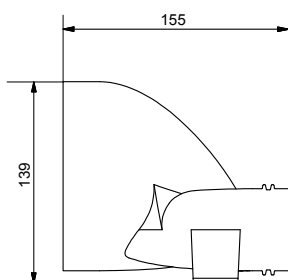

TECHNICAL DATA SHEET:

Straight double adaptor - G0013141

DESCRIPTION

A connection can be made from two flat, oval channels to a round channel using a straight adaptor piece $\varnothing 125$ mm for areas with an extraction flow > 50 m³/h.

The extraction grids can be coupled directly to the straight adaptor if incorporated in a plasterboard wall.

The adaptors may also be used as a transition piece between the flat oval ducts and the round ducts.



Straight double adaptor
2 x 140 x 60 mm > $\varnothing 125$ mm -
G0013141

PRODUCT CHARACTERISTICS

- Made of HDPE RAL 9002
- Anti-static
- Airtightness class D
- Smooth inner wall
 - Low air flow resistance
 - Easy to clean

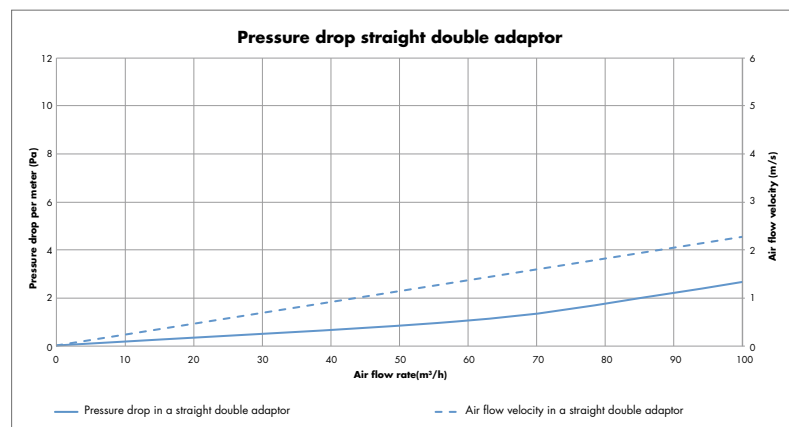

PACKAGING

Art. No.: G0013141
 Afmetingen: 187 x 320 x 129 mm
 Packaging: 12 pieces per box

Type of accessory	Straight double adaptor $\varnothing 125$ mm		
Air flow rate [m ³ /h]	25	50	75
Air flow velocity [m/s]	0,22	0,76	1,57
Pressure drop [Pa]	0,57	1,13	1,70

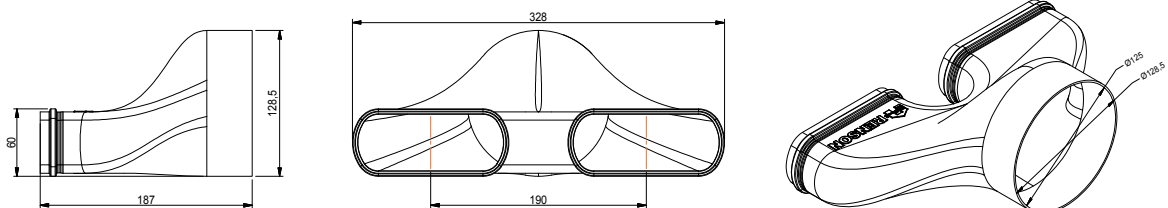

TECHNICAL DATA SHEET:

Round duct \varnothing 80 mm - G0013131

DESCRIPTION

Round ducts are usually used on vertical lengths up to the ventilation system.
We recommend an 80 mm diameter for spaces with an air flow rate of $< 50 \text{ m}^3/\text{h}$.

The length of the concrete duct [G0013133] is 25 cm.



Round duct \varnothing 80 mm - G0013131

PRODUCT CHARACTERISTICS

- Made of PVC RAL 9002
- Anti-static
- Airtightness class D
- Smooth inner wall
 - Low air flow resistance
 - Easy to clean

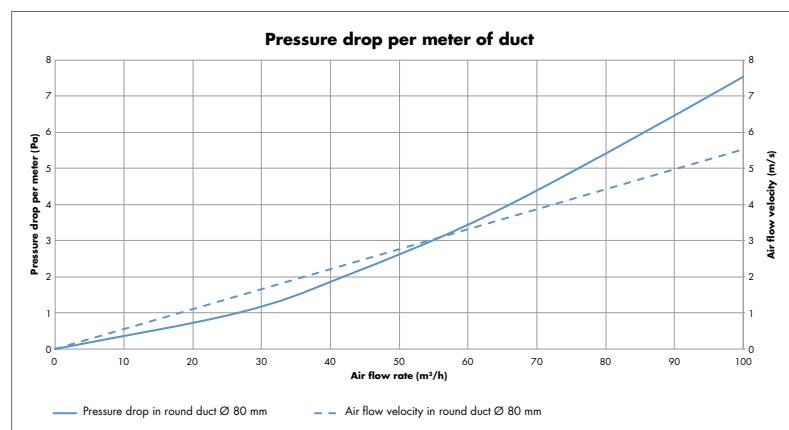

PACKAGING

Art. No.: G0013131
 Diameter: 80 mm
 Length: 3 m
 UV-protected: Wrapped in foil
 End caps: Every duct is carefully sealed with end caps

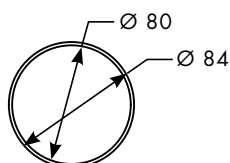

Type of duct	Round duct \varnothing 80 mm					
Air flow velocity [m/s]	0,50	1,00	1,50	2,00	2,50	3,00
Air flow rate [m ³ /h]	9,05	18,10	27,14	36,19	45,24	54,29
Duct length [m]	Pressure drop [Pa]					
1	0,20	0,56	1,04	1,60	2,25	2,97
2	0,39	1,12	2,07	3,21	4,50	5,94
3	0,59	1,68	3,11	4,81	6,75	8,91
4	0,78	2,24	4,15	6,42	9,00	11,88
5	0,98	2,80	5,18	8,02	11,26	14,85
6	1,17	3,36	6,22	9,62	13,51	17,82
7	1,37	3,92	7,25	11,23	15,76	20,79
8	1,56	4,48	8,29	12,83	18,01	23,75
9	1,76	5,04	9,33	14,44	20,26	26,72
10	1,95	5,60	10,36	16,04	22,51	29,69
11	2,15	6,16	11,40	17,65	24,76	32,66
12	2,34	6,72	12,44	19,25	27,01	35,63
13	2,54	7,28	13,47	20,85	29,27	38,60
14	2,74	7,84	14,51	22,46	31,52	41,57
15	2,93	8,40	15,55	24,06	33,77	44,54
16	3,13	8,96	16,58	25,67	36,02	47,51
17	3,32	9,52	17,62	27,27	38,27	50,48
18	3,52	10,08	18,65	28,87	40,52	53,45
19	3,71	10,64	19,69	30,48	42,77	56,42
20	3,91	11,20	20,73	32,08	45,02	59,39

TECHNICAL DATA SHEET:

Connector with integrated rubber gaskets, round \varnothing 80 mm - G0013121

DESCRIPTION

The unique coupling system ensures an almost perfect airtightness. The connector is equipped with two integrated double rubber seals.

Thanks to these seals, the Easyflex® air duct system qualifies for airtightness class D, meaning the system is three times less liable to leak than class C.

The round connector \varnothing 80 mm can be used to couple:

- Round duct \varnothing 80 mm [G0013131]
- Concrete duct \varnothing 80 mm [G0013133]
- All accessories \varnothing 80 mm

The coupling can be reinforced with PVC tape [66014115].

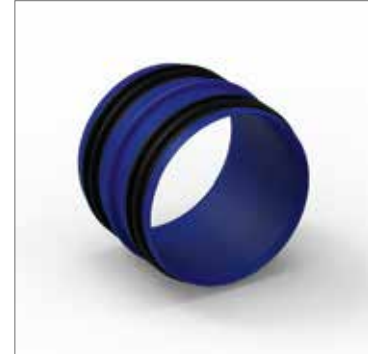

Connector with integrated rubber gaskets, round \varnothing 80 mm - G0013121

PRODUCT CHARACTERISTICS

- Made of polypropylene
- Rubber sealing: TPE [ThermoPlastic Elastomer]
- Airtightness class D
- Smooth inner wall
 - Low air flow resistance
 - Easy to clean

PACKAGING

Art. No.: G0013121
Dimensions: 80 x 62,5 mm
Packaging: 100 pieces per box

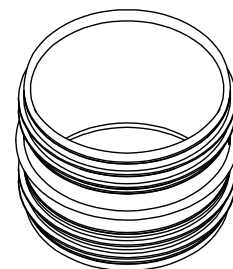
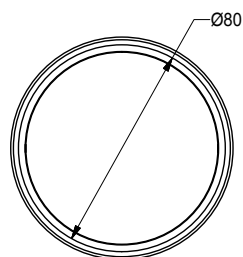
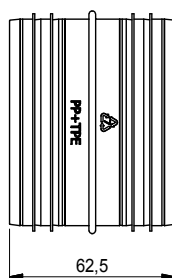

TECHNICAL DATA SHEET:

Valve connection \varnothing 80 mm - G0013116

DESCRIPTION

You can make seamless connections between RENSON® design extraction louvres or SQair valves and valve connectors in an Easyflex® air duct system. Valve connectors come in two diameters: \varnothing 80 mm in-line connectors for spaces with an extraction air flow rate $\leq 50 \text{ m}^3/\text{h}$ and \varnothing 125 mm for spaces with an extraction air flow rate $\geq 50 \text{ m}^3/\text{h}$.

You can connect extraction grills directly to the valve transits, if they are built into a Gyproc wall. If the extraction louver is fitted in a vaulted surface, you can use a connector that you can saw along its length.

You can also use valve connectors as a connecting piece to join flat, oval duct to round ducts.



Valve connection \varnothing 80 mm - G0013116

PRODUCT CHARACTERISTICS

- Made of polypropylene RAL 9002
- Anti-static and antibacterial
- Airtightness class D
- Smooth inner wall
 - Low air flow resistance
 - Easy to clean

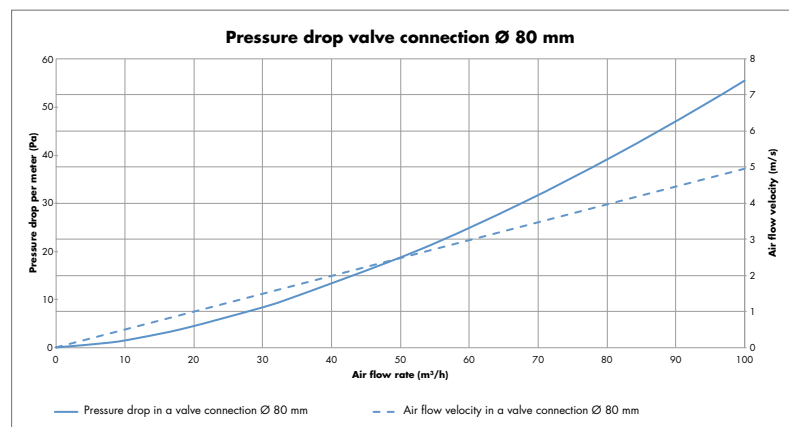

PACKAGING

Art. No.: G0013116
 Dimensions: 147 x 140 x 114 mm
 Packaging: 20 pieces per box

Type of accessory	Valve connection \varnothing 80 mm		
Air flow rate [m^3/h]	25	50	75
Air flow velocity [m/s]	1,24	2,48	3,72
Pressure drop [Pa]	6,28	18,68	35,33

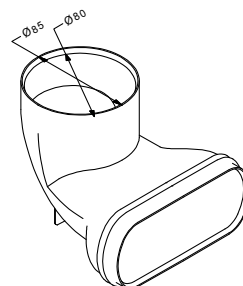
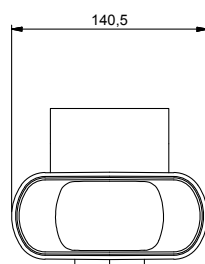
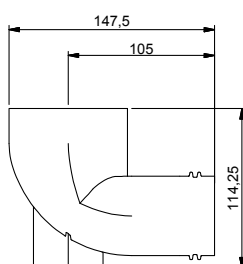

TECHNICAL DATA SHEET:

Adaptor flat to round - G0013123

DESCRIPTION

You can make a transition connection between an oval and round duct by using an in-line connector. You can use $\varnothing 80$ mm in-line connectors for spaces with an extraction air flow rate ≤ 50 m³/h and $\varnothing 125$ mm for spaces with an extraction air flow rate ≥ 50 m³/h.

You can connect extraction grills directly to in-line connectors, if they are built into a Gyproc wall.

And you can use in-line connectors to join flat, oval ducts to round ducts.



Adaptor flat to round
140 x 60 mm > $\varnothing 80$ mm - G0013123

PRODUCT CHARACTERISTICS

- Made of polypropylene RAL 9002
- Anti-static and antibacterial
- Airtightness class D
- Smooth inner wall
 - Low air flow resistance
 - Easy to clean

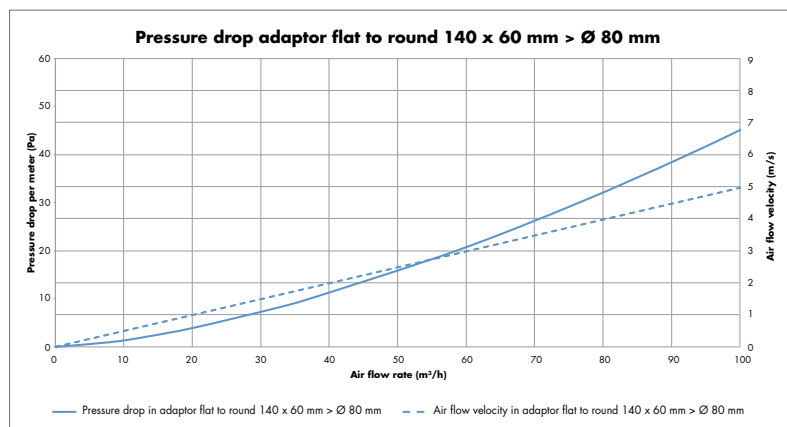

PACKAGING

Art. No.: G0013123
Dimensions: 120 x 185 x 94 mm
Packaging: 20 pieces per box

Type of accessory	Adaptor flat to round $\varnothing 80$ mm		
Air flow rate [m ³ /h]	25	50	75
Air flow velocity [m/s]	1,24	2,48	3,72
Pressure drop [Pa]	5,49	15,72	29,11

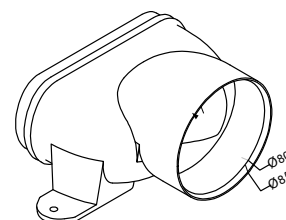
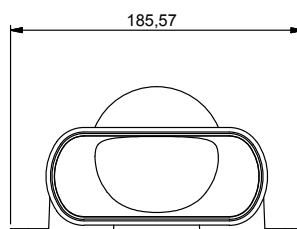
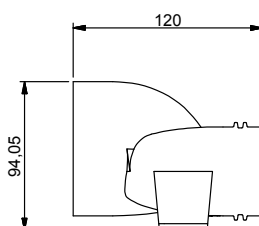

TECHNICAL DATA SHEET:

Cross piece pivot - G0013145

DESCRIPTION

The cross piece is a part of the Easyflex selection. This cross piece makes it possible to cross lines with a height of 65 mm.

The pivoting feature ensures you can determine the angle in which the lines cross each other for yourself. In this way, no extra distances and turns are required to meet a 90° angle. With the pivot cross piece, it is possible to bridge angles from 45° to 135°.

Bridging obstacles up to 3 cm in height is also possible with this piece. Support with 'pur' is recommended.



Cross piece pivot - G0013145

PRODUCT CHARACTERISTICS

- Made of HDPE RAL 9002
- Anti-static
- Airtightness class D
- Smooth inner wall
 - Low air flow resistance
 - Easy to clean

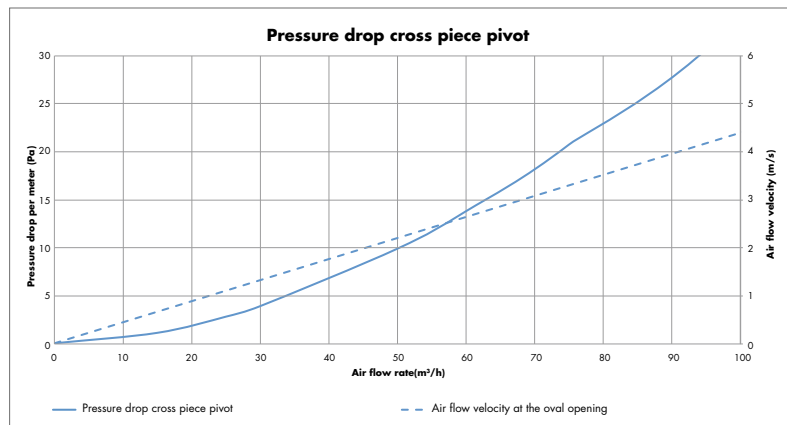

PACKAGING

Art. No.: G0013145
 Set contains: 2 x bridge piece (together they form the cross piece)
 4 x fastening bracket (G0013137)
 Dimensions: 385 x 230 x 145 mm

Type of accessory	Cross piece pivot		
Air flow rate [m³/h]	25	50	75
Air flow velocity [m/s]	1,10	2,20	3,30
Pressure drop [Pa]	2,78	9,88	20,74

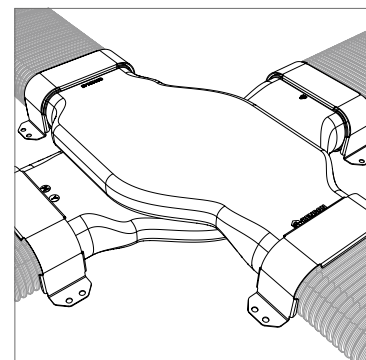
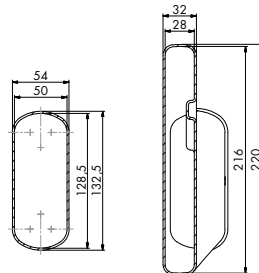
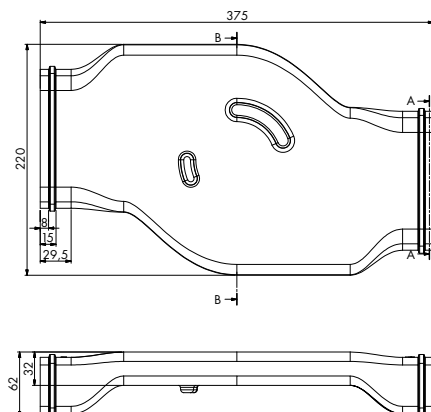

TECHNICAL DATA SHEET:

Distribution box angled 160 mm - G0013135

DESCRIPTION

The distribution box is part of the Easyflex® range. This distribution box has an angled main connection of 160 mm and there are up to 6 ducts that can be connected to it.

By joining the distribution box to the supply and extract ducts of a ventilation system D, an easy installation is guaranteed. The Easyflex® ducts can directly be connected to the distribution box by means of the supplied Easyflex® fastening brackets [G0013137].

The limited height of the Easyflex® distribution box makes it easy to recess the box and its ducts in screed, concrete or stud walls or false ceilings.

The distribution box's broad cross section and the tube connections allow high air flow rates at low velocities, which leads to quiet ventilation system operation.



Distribution box angled 160 mm - G0013135

PRODUCT CHARACTERISTICS

- Made of HDPE RAL 9002
- Anti-static
- Airtightness class D
- Smooth inner wall
 - Low air flow resistance
 - Easy to clean

PACKAGING

Art. No.: 1 set = 2 x G0013135
 Set contains: 2 x distribution box [G0013135]
 12 x fastening bracket [G0013137]
 Dimensions: 470 x 590 x 190 mm

To limit decomposition, tubes should be connected in the following order [1 - 2 - 3] if possible.

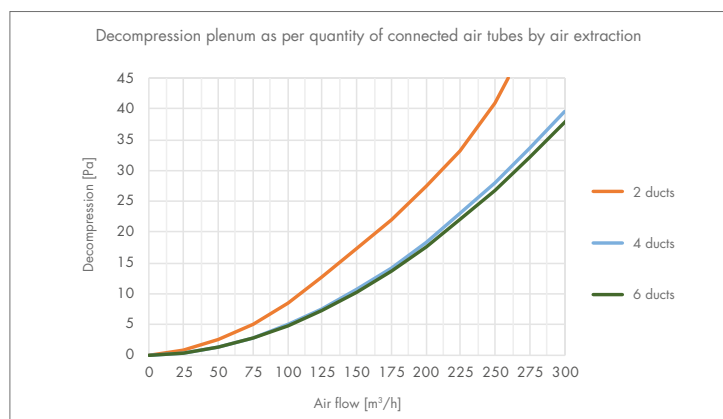
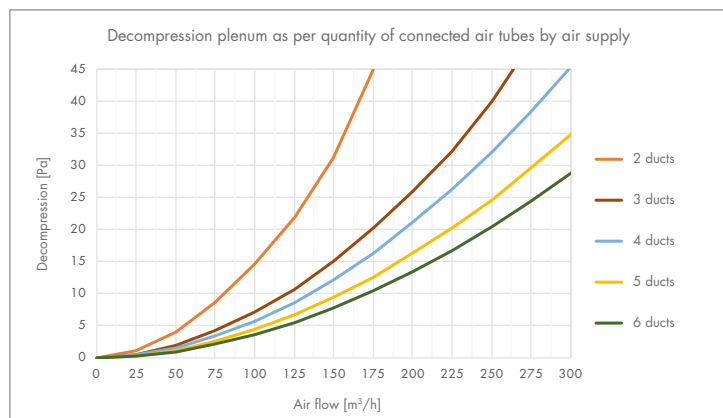
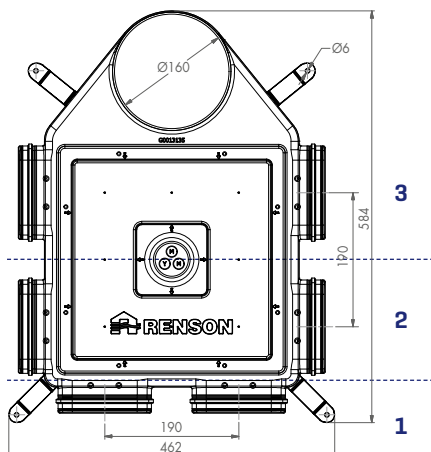

TECHNICAL DATA SHEET:

Distribution box 8 connections - G0013136

DESCRIPTION

The distribution box is part of the Easyflex® range. This distribution box can provide supply using two Easyflex® ducts and can be connected to up to six ducts. In this way, the distribution box can be placed centrally, rather than coupled directly to the main duct.

The two supply lines can be coupled using the double valve connection [G0013118] or the straight double adapter [G0013141].

By joining the distribution box to the supply and extract ducts of a ventilation system D, an easy installation is guaranteed. The Easyflex® ducts can directly be connected to the distribution box by means of the supplied Easyflex® fastening brackets [G0013137].

The limited height of the Easyflex® distribution box makes it easy to recess the box and its ducts in screed, concrete or stud walls or false ceilings.

The distribution box's broad cross section and the tube connections allow high air flow rates at low velocities, which leads to quiet ventilation system operation.



Distribution box 8 connections - G0013136

PRODUCT CHARACTERISTICS

- Made of HDPE RAL 9002
- Anti-static
- Airtightness class D
- Smooth inner wall
 - Low air flow resistance
 - Easy to clean

PACKAGING

Art. No.: 1 set = 2 x G0013136
 Set contains: 2 x distribution box [G0013136]
 16 x fastening bracket [G0013137]
 Dimensions: 443 x 452 x 64 mm

To limit decompression, tubes should be connected in the following order [1 - 2 - 3] if possible.

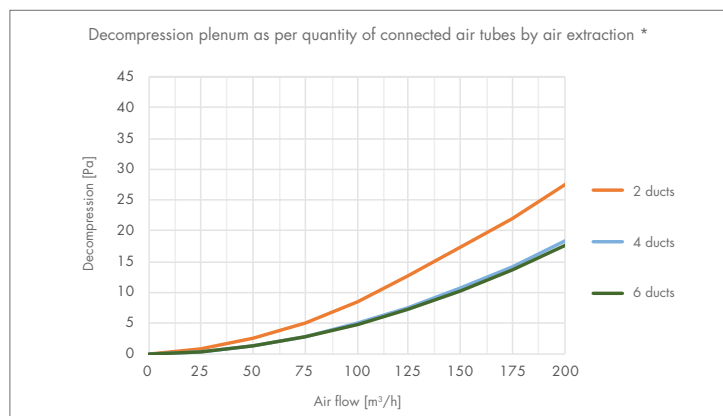
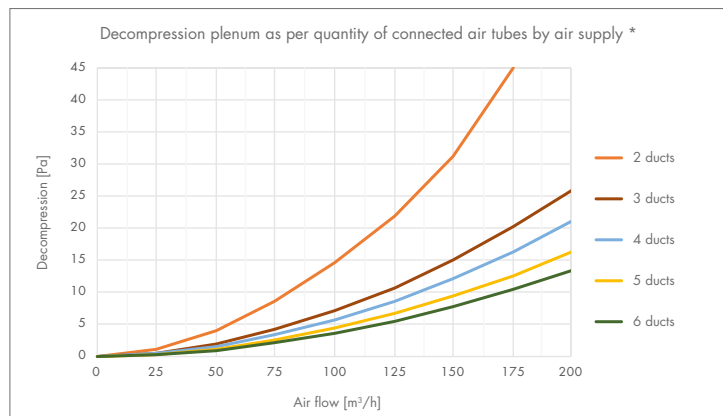
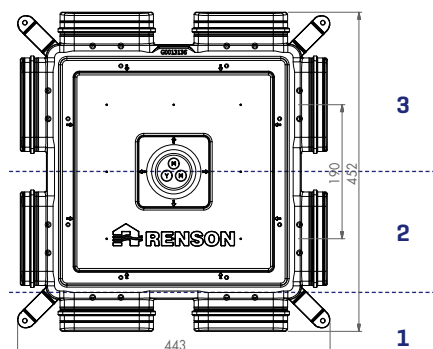

* Provisional results



TECHNICAL DATA SHEET:

Distribution box straight 160 mm - G0013140

DESCRIPTION

The distribution box is part of the Easyflex® range. This distribution box has a straight main connection of 160 mm, and can be connected to up to six ducts.

By joining the distribution box to the supply and extract ducts of a ventilation system D, an easy installation is guaranteed. The Easyflex® ducts can directly be connected to the distribution box by means of the supplied Easyflex® fastening brackets [G0013137].

The limited height of the Easyflex® distribution box makes it easy to recess the box and its ducts in screed, concrete or stud walls or false ceilings.

The distribution box's broad cross section and the tube connections allow high air flow rates at low velocities, which leads to quiet ventilation system operation.



Distribution box straight 160 mm - G0013140

PRODUCT CHARACTERISTICS

- Made of HDPE RAL 9002
- Anti-static
- Airtightness class D
- Smooth inner wall
 - Low air flow resistance
 - Easy to clean

PACKAGING

Art. No.: 1 set = 2 x G0013140
 Set contains: 2 x distribution box [G0013140]
 12 x fastening bracket [G0013137]
 Dimensions: 470 x 590 x 190 mm

To limit decompression, tubes should be connected in the following order [1 - 2 - 3] if possible.

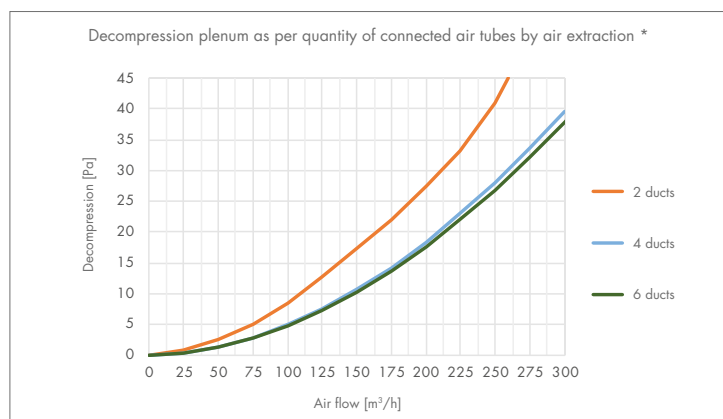
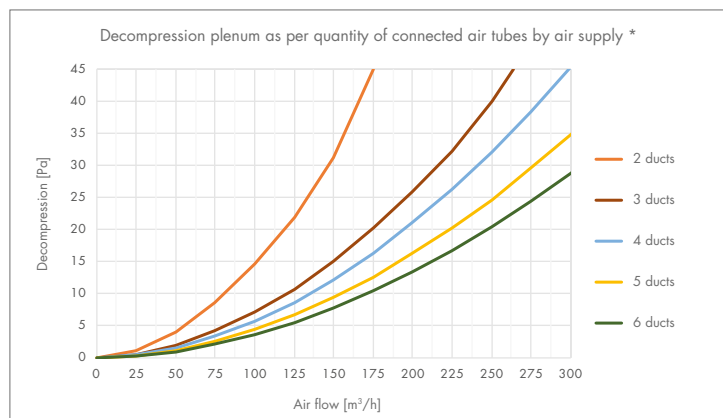
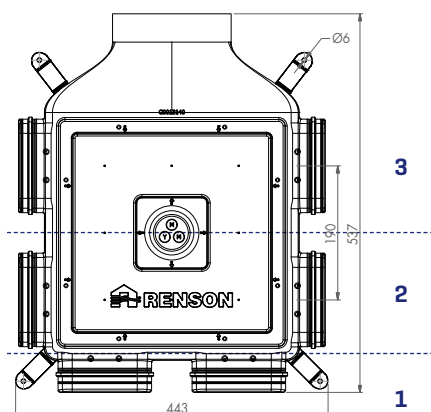

* Provisional results

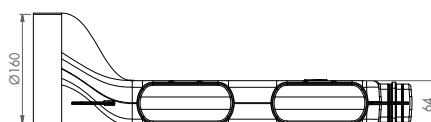

TECHNICAL DATA SHEET:

Inspection hatch - 76050405

DESCRIPTION

Each distribution box can be transformed into a distribution box with inspection hatch within a few minutes. The screws are included and make sure that the inspection hatch can be installed [opened and closed] in no time at all. It can be built in at the top as at the bottom and is therefore fit for use in screed, concrete, stud walls or false ceilings.

The durable inspection hatch of high quality, allows a permanent access to the Easyflex® air duct system for cleaning and/or inspecting its parts.

The inspection date, the person responsible and all possible remarks can be indicated on the inspection label, so that maintenance can continuously and precisely be followed-up.

Thanks to the sealing foam there is perfect tightness of the air duct system, so that the air flow is optimized.

The inspection hatch can be built-in in:

- Distribution box straight 160 mm [G0013140]
- Distribution box angled 160 mm [G0013135]
- Distribution box 8 connections [G0013136]



Inspection hatch - 76050405

PRODUCT CHARACTERISTICS

- Made of galvanized steel
- Sealing foam

PACKAGING

Art. No.:	76050405
Set contains:	1 x inspection hatch [76050405] 8 x screws 8 x clips
Dimensions:	316 x 316 x 7,5 mm
Packaging:	Per piece

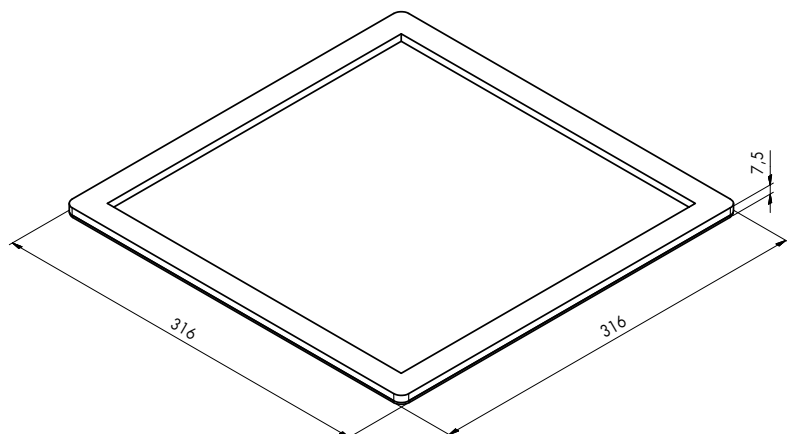

TECHNICAL DATA SHEET:

Insulation tube 160 mm - 66031400

DESCRIPTION

The Easyflex insulation tube can be used for insulating the flat oval ducts and is therefore ideal for non-insulated areas.

The low thermal conductivity of the foam ensures the correct surface temperature and thus prevents formation of condensation water. The great water vapor diffusion resistance guarantees this feature throughout the life cycle of the installation, resulting in minimal energy loss and higher efficiency.

The insulation tube is also acoustically damping.

The Easyflex ducts that can be insulated with the insulation tube are:

- The flexible Easyflex® duct [G0013110]
- The flat oval duct Easyflex® [G0013126]



Insulation tube - 66031400

PRODUCT CHARACTERISTICS

- Made of elastomeric foam
- Thermal conductivity: 0,034 W/mK at 0°C [EN ISO 8497]
- Temperature range: -30 to 100°C [EN 14707]

PACKAGING

Art. No.: 66031400
Dimensions: 140 x 60 x 13 mm
Length: 2 m
Packaging: Per piece

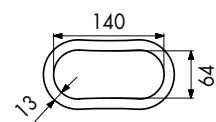
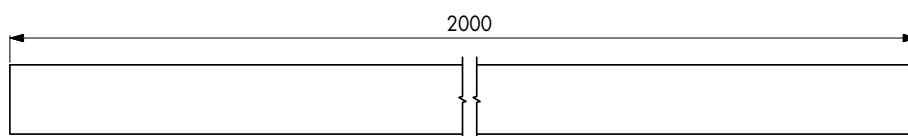
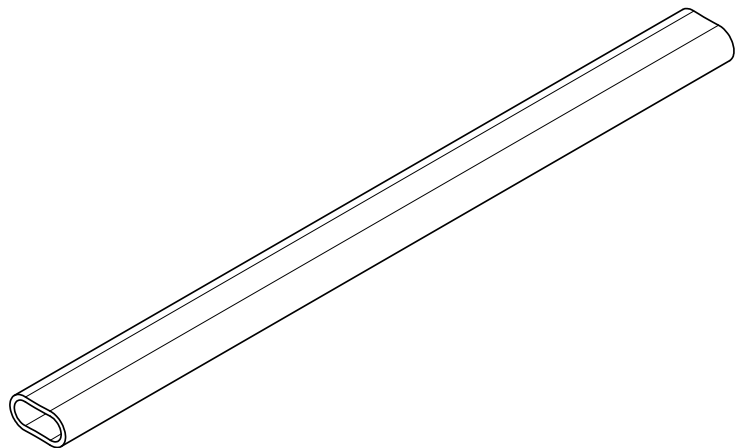

TECHNICAL DATA SHEET:

Easyflex® for multiple rooms

2 ROOMS

Ø 125 → 2 x [140 x 60]

140 x 60 → 2 x [140 x 60]

G0013118 or G0013141

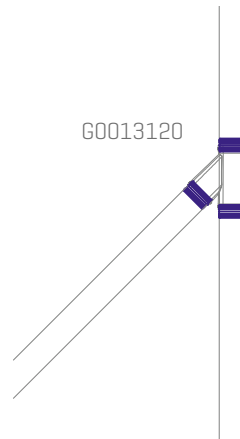
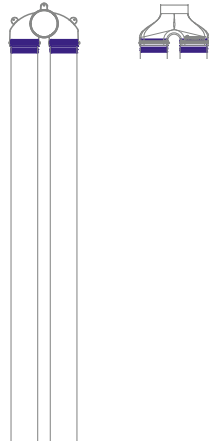

G0013120

3 ROOMS

Ø 125 → 3 x [140 x 60]

4 ROOMS

Ø 125 → 4 x [140 x 60]

G0013118 or G0013141

G0013118 or G0013141

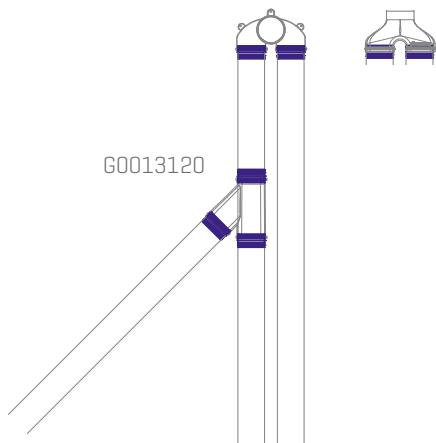

G0013120

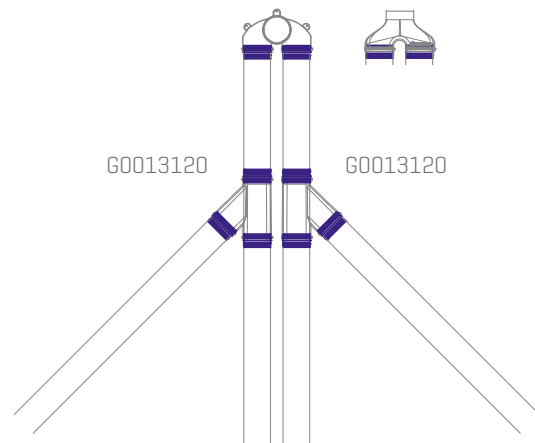

G0013120

G0013120

TECHNICAL DATA SHEET:

Easyflex® for multiple rooms

4 to 6 ROOMS

Ø 160 → 4 to 6 x [140 x 60]

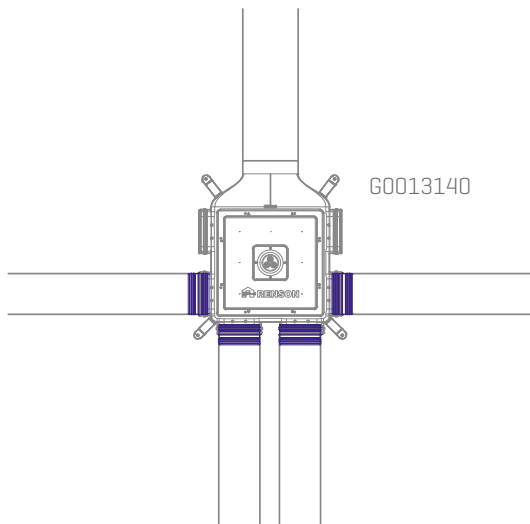

Ø 160 → 4 to 6 x [140 x 60]

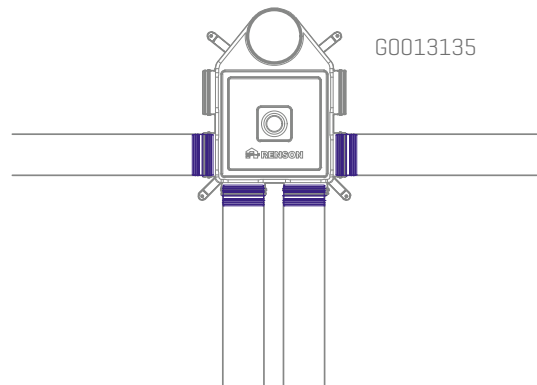

Ø 125 → 4 to 6 x [140 x 60]

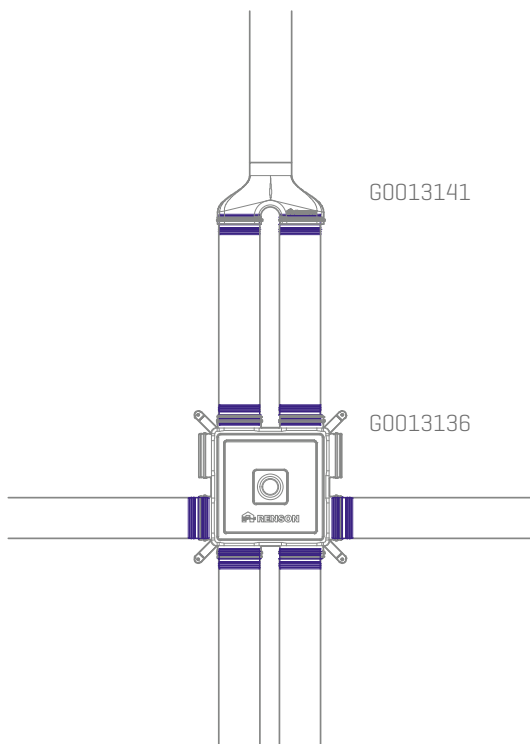

Ø 125 → 4 to 6 x [140 x 60]

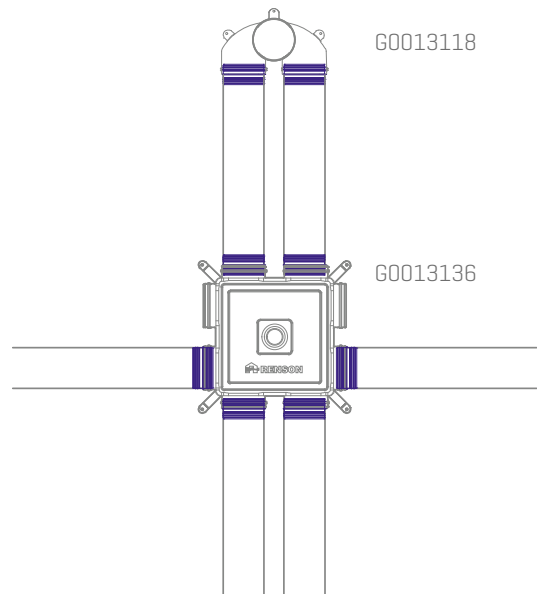

TECHNICAL DATA SHEET:

Design roof exhausts



Design roof exhaust
66014096



Design roof exhaust
66014097



Design roof exhaust for slate roofs
66014095

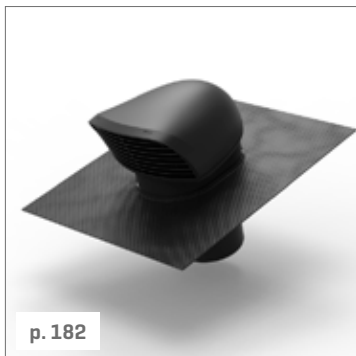

Design roof exhaust Flex
66014150

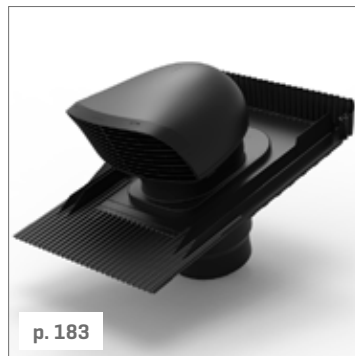

Design roof exhaust XL
66014152

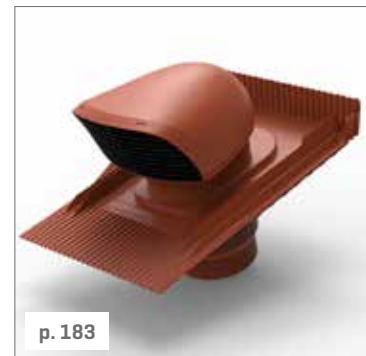

Design roof exhaust XL
66014154



Design roof exhaust for slate roofs XL
66014153

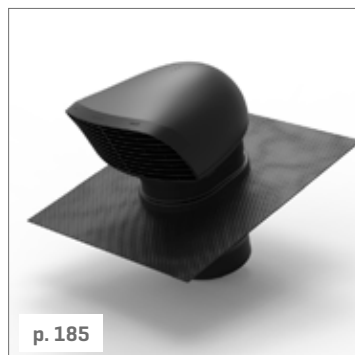

Design roof exhaust Flex XL
66014151



Roof supply All Weather black
76050402

TECHNICAL DATA SHEET:

Design roof exhaust: 66014096 - 66014097

PRODUCT CHARACTERISTICS

- Low pressure drop:
 - 14 Pa at 250 m³/h
 - 30 Pa at 375 m³/h
- Connection diameter 150/160 mm
- Material: polypropylene
 - Weather- and shockproof
 - Recyclable
 - Resists constant temperatures between -30 °C up to 80 °C
 - UV-protected
- Built-in with universal roof tile
 - Lead replacement material
 - Possibility for different angles of inclination
 - Compatible with most types of roof tiles
- Aesthetic design
- Exhaust parallel with the roof [less fouling]
- Removable louvre for cleaning, if necessary
- Dimensions:
 - Roof exhaust: 316 x 257 x 389 mm [L x W x H]
 - Universal roof tile: 532 x 400 mm [L x W]

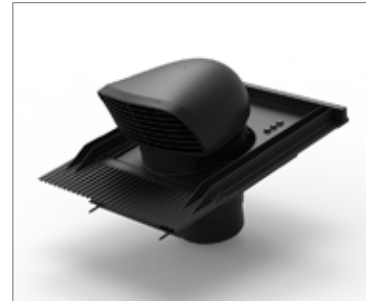
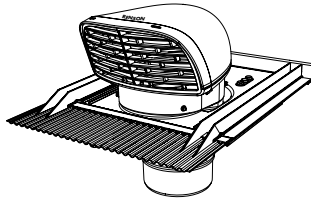

66014096



66014097

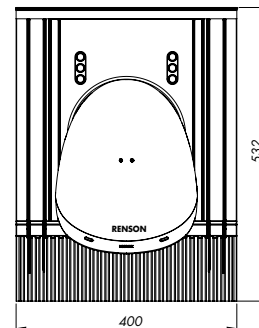
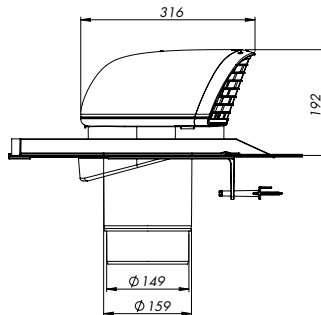
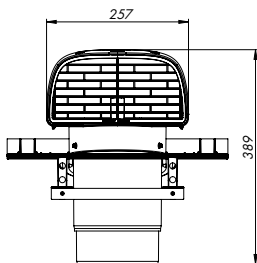

CURVE PRESSURE DROP (exhaust)

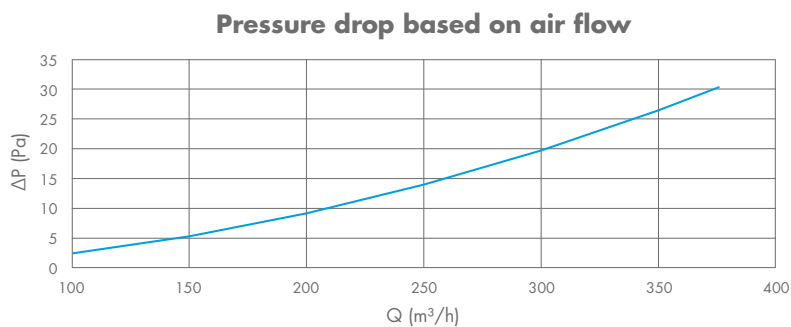

Q [m ³ /h]	Δp [Pa]
100	2,5
150	5,3
200	9,2
250	14
300	19,8
350	26,6
375	30,3

TECHNICAL DATA SHEET:

Design roof exhaust for slate roofs - 66014095

PRODUCT CHARACTERISTICS

- Low pressure drop:
 - 14 Pa at 250 m³/h
 - 30 Pa at 375 m³/h
- Connection diameter 150/160 mm
- Material: polypropylene
 - Weather- and shockproof
 - Recyclable
 - Resists constant temperatures between -30 °C up to 80 °C
 - UV-protected
- Built-in with slate roof tile
 - Lead replacement material
 - Possibility for different angles of inclination
- Aesthetical design
- Exhaust parallel with the roof (less fouling)
- Removable louvre for cleaning, if necessary
- Dimensions:
 - Roof exhaust: 316 x 257 x 389 mm [L x W x H]
 - Slate roof tile: 450 x 380 mm [L x W]

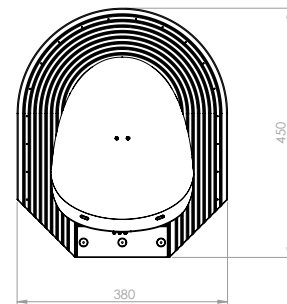
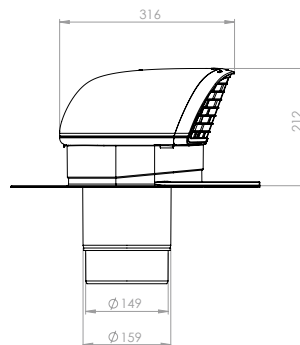
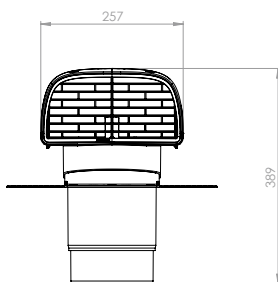
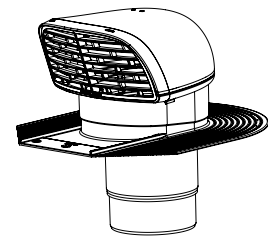

CURVE PRESSURE DROP (exhaust)

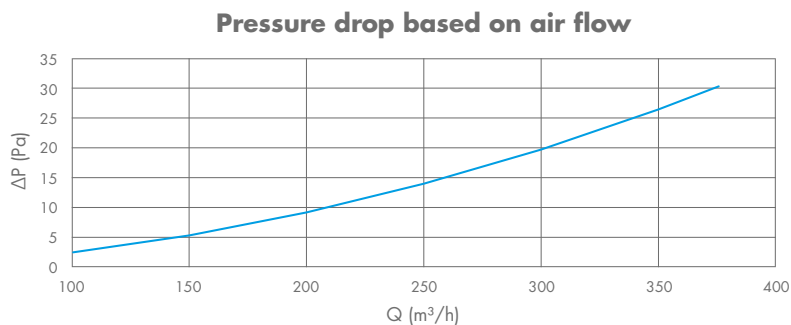

Q [m ³ /h]	Δp [Pa]
100	2,5
150	5,3
200	9,2
250	14
300	19,8
350	26,6
375	30,3

TECHNICAL DATA SHEET:

Design roof exhaust Flex - 66014150

PRODUCT CHARACTERISTICS

- Low pressure drop:
 - 14 Pa at 250 m³/h
 - 30 Pa at 375 m³/h
- Connection diameter 150/160 mm
- Material: polypropylene
 - Weather- and shockproof
 - Recyclable
 - Resists constant temperatures between -30 °C up to 80 °C
 - UV-protected
- Built-in with a fierce lead-free flexible slab:
 - Lead replacement based on silicone with aluminium reinforcement
 - Remains strong and sustainable within a big range of temperatures: -30 °C/+180 °C [-22 °F/+356 °F]
 - UV-resistant
 - Does not react with roofing and does not cause stripes
 - Faster to process than lead or other lead replacement materials
 - Easy to crease by hand or by lead beaters
 - Harmless for people and environment and light weighted
- Aesthetical design
- Exhaust parallel with the roof [less fouling]
- Removable louvre for cleaning, if necessary
- Dimensions:
 - Roof exhaust: 316 x 257 x 389 mm [L x W x H]
 - Flexible slab: 560 x 454 mm [L x W]

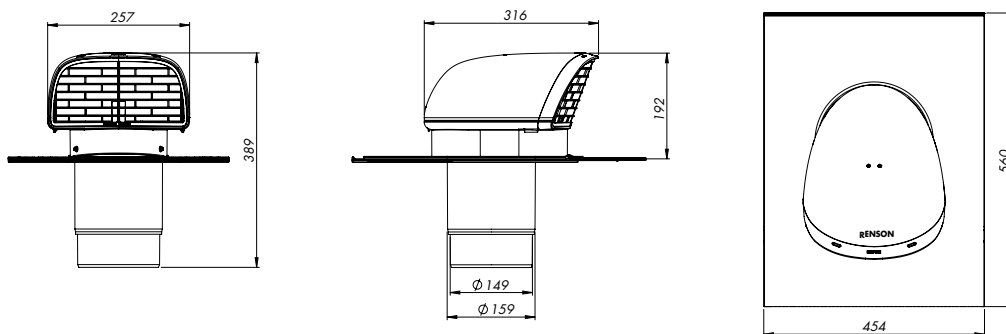
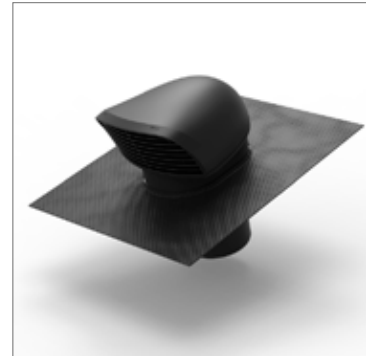

CURVE PRESSURE DROP [exhaust]

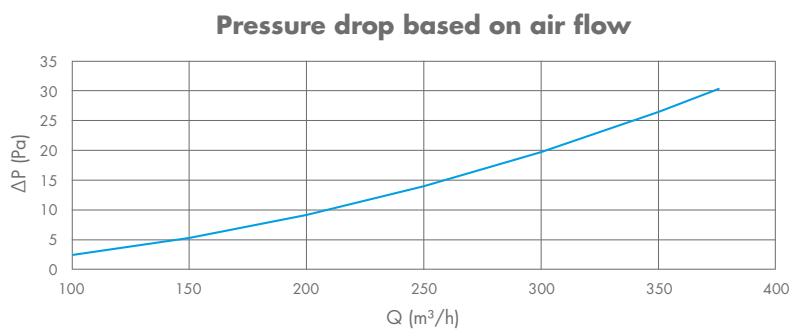

Q [m ³ /h]	Δp [Pa]
100	2,5
150	5,3
200	9,2
250	14
300	19,8
350	26,6
375	30,3

TECHNICAL DATA SHEET:

Design roof exhaust XL - 66014152 - 66014154

PRODUCT CHARACTERISTICS

- Low pressure drop:
 - Exhaust: 10 Pa at 404 m³/h - 20 Pa at 584 m³/h
 - Intake: 10 Pa at 334 m³/h - 20 Pa at 467 m³/h
- Connection diameter 180/200 mm
- Material: polypropylene
 - Weather- and shockproof
 - Recyclable
 - Resists constant temperatures between -30 °C up to 80 °C
 - UV-protected
- Built-in with universal roof tile
 - Lead replacement material
 - Possibility for different angles of inclination
 - Compatible with most types of roof tiles
- Aesthetic design
- Exhaust parallel with the roof (less fouling)
- Removable louvre for cleaning, if necessary
- Dimensions:
 - Roof exhaust: 369 x 301 x 456 mm [L x W x H]
 - Universal roof tile: 532 x 400 mm [L x W]

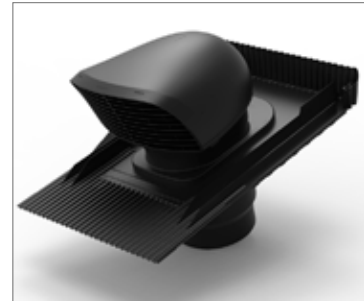

66014152

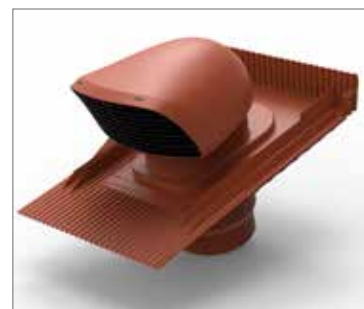

66014154

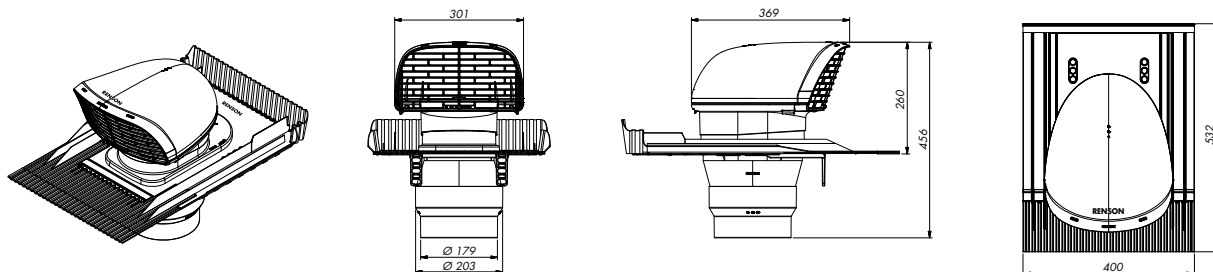

CURVES PRESSURE DROP (exhaust-intake)

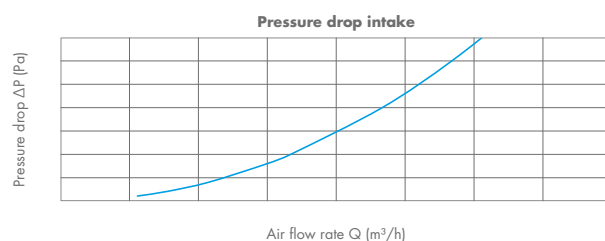
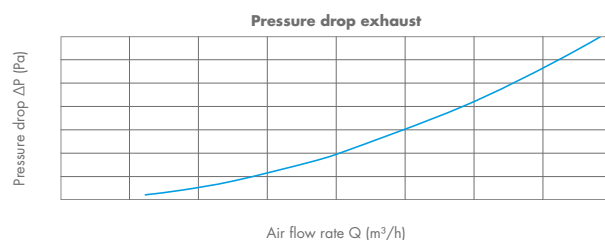

Δp [Pa]	Intake Q [m ³ /h]	Exhaust Q [m ³ /h]
1	110	120
2	153	173
4	214	249
8	300	359
10	334	404
20	467	584
30	568	723

TECHNICAL DATA SHEET:

Design roof exhaust for slate roofs XL - 66014153

PRODUCT CHARACTERISTICS

- Low pressure drop:
 - Exhaust: 10 Pa at 404 m³/h - 20 Pa at 584 m³/h
 - Intake: 10 Pa at 334 m³/h - 20 Pa at 467 m³/h
- Connection diameter 180/200 mm
- Material: polypropylene
 - Weather- and shockproof
 - Recyclable
 - Resists constant temperatures between -30 °C up to 80 °C
 - UV-protected
- Built-in with slate roof tile
 - Lead replacement material
 - Possibility for different angles of inclination
- Aesthetical design
- Exhaust parallel with the roof [less fouling]
- Removable louvre for cleaning, if necessary
- Dimensions:
 - Roof exhaust: 369 x 301 x 456 mm [L x W x H]
 - Slate roof tile: 450 x 380 mm [L x W]

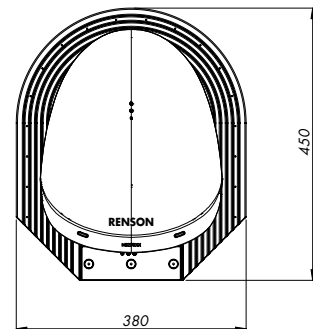
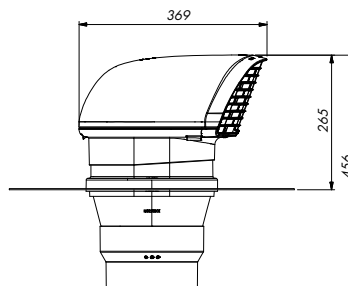
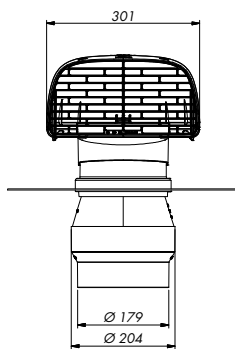
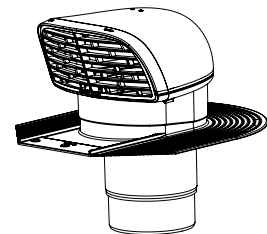

CURVES PRESSURE DROP [exhaust-intake]

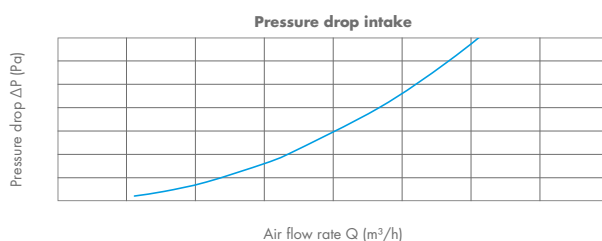
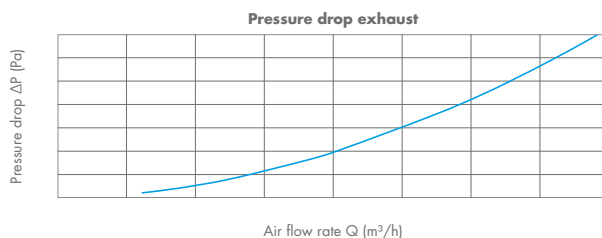

Δp [Pa]	Intake Q [m ³ /h]	Exhaust Q [m ³ /h]
1	110	120
2	153	173
4	214	249
8	300	359
10	334	404
20	467	584
30	568	723

TECHNICAL DATA SHEET:

Design roof exhaust Flex XL - 66014151

PRODUCT CHARACTERISTICS

- Low pressure drop:
 - Exhaust: 10 Pa at 404 m³/h - 20 Pa at 584 m³/h
 - Intake: 10 Pa at 334 m³/h - 20 Pa at 467 m³/h
- Connection diameter 180/200 mm
- Material: polypropylene
 - Weather- and shockproof
 - Recyclable
 - Resists constant temperatures between -30 °C up to 80 °C
 - UV-protected
- Built-in with a fierce lead-free flexible slab:
 - Lead replacement based on silicone with aluminium reinforcement
 - Remains strong and sustainable within a big range of temperatures: -30 °C/+180 °C [-22 °F/+356 °F]
 - UV-resistant
 - Does not react with roofing and does not cause stripes
 - Faster to process than lead or other lead replacement materials
 - Easy to crease by hand or by lead beaters
 - Harmless for people and environment and light weighted
- Aesthetical design
- Exhaust parallel with the roof [less fouling]
- Removable louvre for cleaning, if necessary
- Dimensions:
 - Roof exhaust: 369 x 301 x 456 mm [L x W x H]
 - Flexible slab: 560 x 454 mm [L x W]

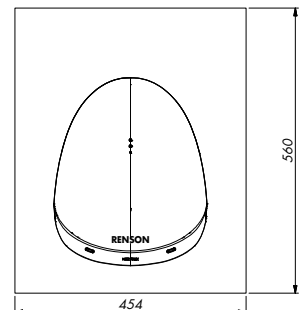
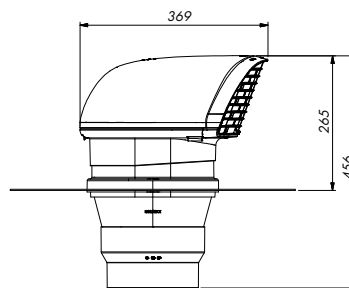
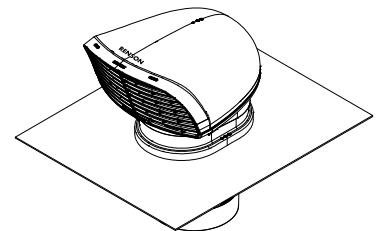
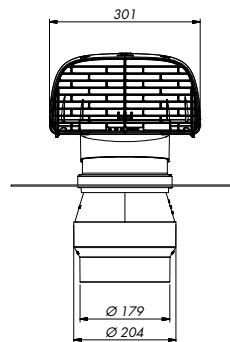
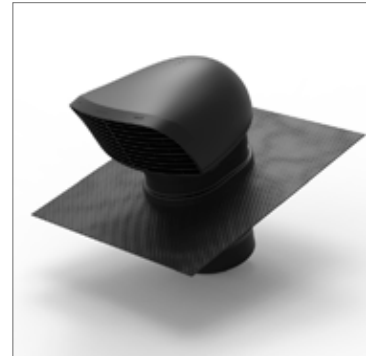

CURVES PRESSURE DROP (exhaust-intake)

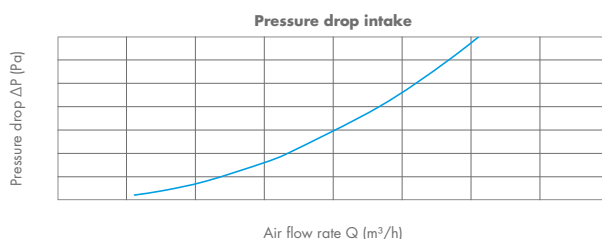
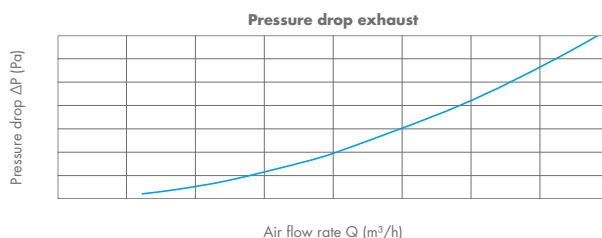

Δp [Pa]	Intake Q [m ³ /h]	Exhaust Q [m ³ /h]
1	110	120
2	153	173
4	214	249
8	300	359
10	334	404
20	467	584
30	568	723

TECHNICAL DATA SHEET:

Roof supply All Weather - 76050402

PRODUCT CHARACTERISTICS

- Water repellent roof supply: according to EN13030:2001, class A at 3 m/s
- Low pressure drop:
 - Exhaust: 10 Pa at 281 m³/h - 30 Pa at 494 m³/h
 - Intake: 10 Pa at 180 m³/h - 60 Pa at 456 m³/h
- Connection diameter 160 mm
- Material: polypropylene
 - Weather- and shockproof
 - Recyclable
 - Resists constant temperatures between -30 °C up to 80 °C
 - UV-protected
- Built-in with the roof tiles mentioned below
 - Lead replacement material
 - Possibility for different angles of inclination
 - Compatible with most types of roof tiles
- Aesthetic design with internal mechanism against water penetration
- Removable top part for cleaning, if necessary
- Dimensions: 333 x 808 mm [B x H]

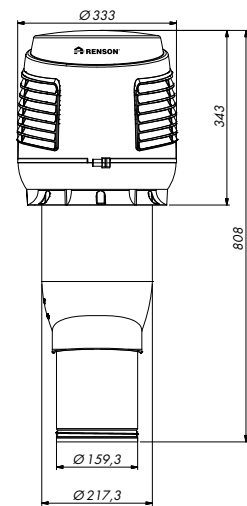
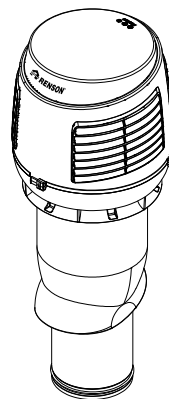

Installation only in combination with:

Black - 66032302

Terracotta - 66032303

Felt pass through - 66032304

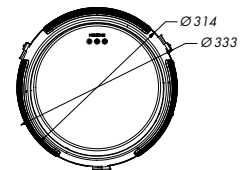
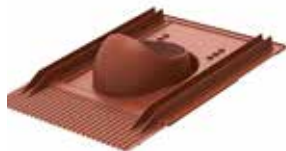
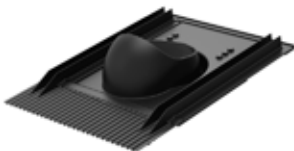

CURVES PRESSURE DROP [exhaust-intake]

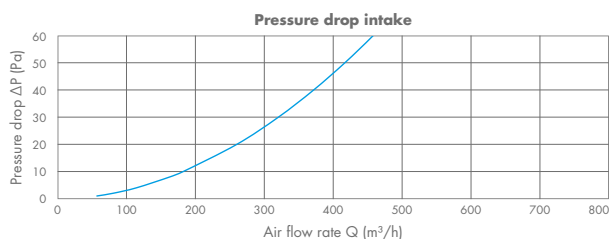
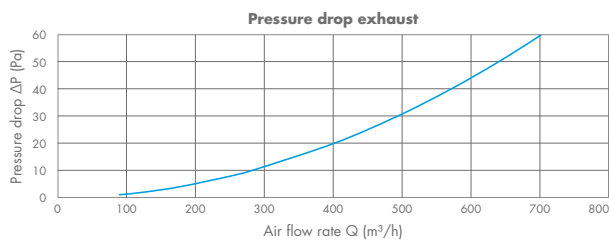

Δp [Pa]	Intake Q [m ³ /h]	Exhaust Q [m ³ /h]
1	55	86
2	78	123
4	112	176
8	160	251
10	180	281
20	258	401
30	318	494
40	370	573
50	415	642
60	456	705

TECHNICAL DATA SHEET:

Wall exhaust: 66114053 - 66614053 - 66714053

The plenum of the wall exhaust is attached to the grid.

AVAILABLE MODELS

According to the available colors of the grid:

- Satin anodised [20 micron] [66114053]
- White RAL 9010 [66614053]
- Brown RAL 8019 [66714053]

DIMENSIONS

Base of the plenum: 286 x 286 mm

Height of the plenum: 78,6 mm

Grid: 325 x 325 mm

Inside diameter: Ø 150 mm

Outside diameter: Ø 157 mm

Structural dimension [fitting dimensions]: 300 x 300 mm
provide clips for attachment

No insect mesh

PRESSURE DROP - FLOW

[when used as exhaust]

Δp [Pa]	Q [m ³ /h]
3,8	125
9,3	200
19,8	300
26,5	350
34,1	400
51,8	500
72,9	600



Grille and plenum

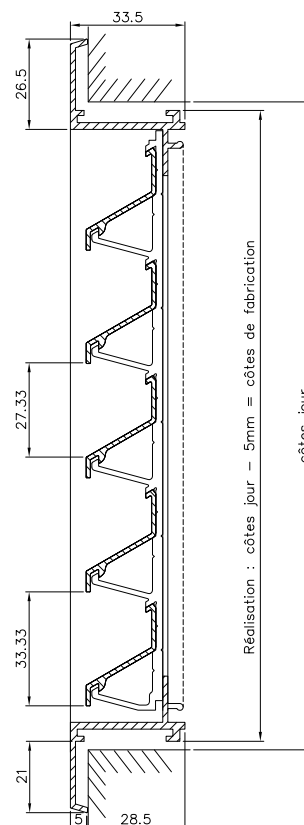

TECHNICAL DATA SHEET:

Wall exhaust: 76050001 - 76050002

Wall exhaust with drainage

- Drainage to prevent moisture on the facade

AVAILABLE MODELS

According to the available colors of the grid:

- Black [76050001]
- White [76050002]



DIMENSIONS

Base of the exhaust: 230 x 267 mm
 Depth of the exhaust: 109 mm
 Diameter: Ø 150 mm

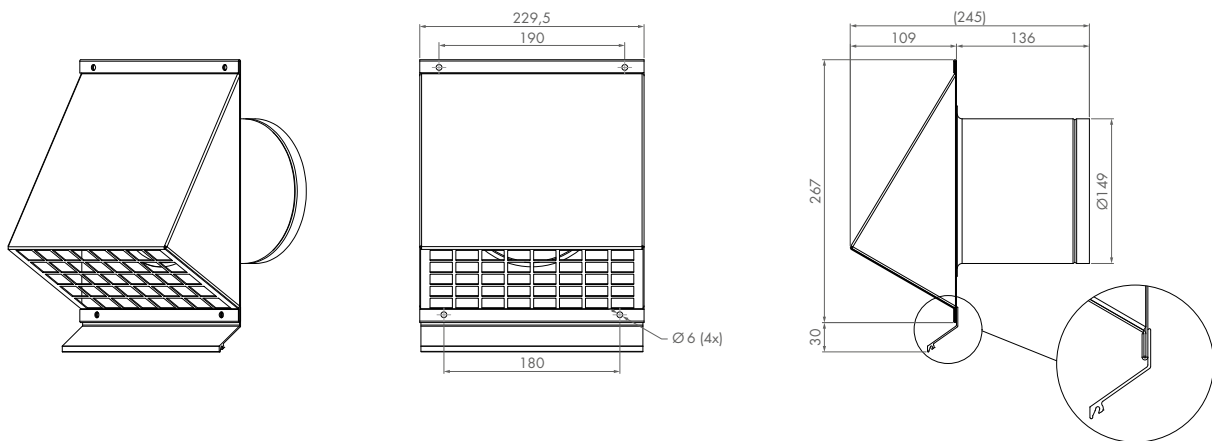

PRESSURE DROP - FLOW

INTAKE	
Q [m³/h]	Δp [Pa]
100	5,7
150	12,5
200	21,7
250	33,4
300	47,4
350	63,7
400	82,3
450	103,3

EXHAUST	
Q [m³/h]	Δp [Pa]
100	2,2
150	4,8
200	8,3
250	12,8
300	18,2
350	24,5
400	31,7
450	39,8

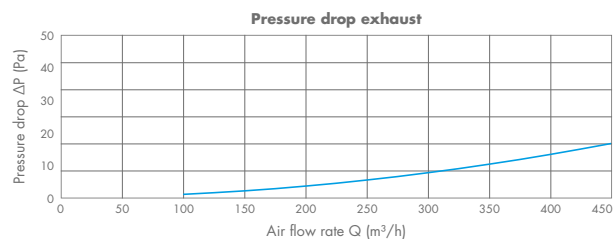
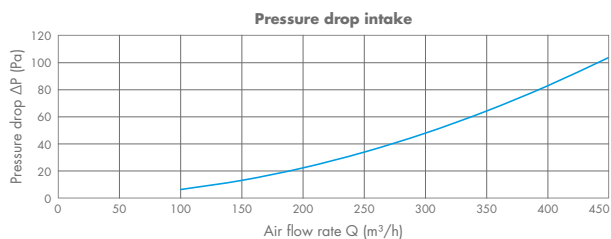

TECHNICAL DATA SHEET:

Wall exhaust: 76050003 - 76050004

Wall exhaust with drainage

- Drainage to prevent moisture on the facade

AVAILABLE MODELS

According to the available colors of the grid:

- Black [76050003]
- White [76050004]



DIMENSIONS

Base of the exhaust: 300 x 312 mm
 Depth of the exhaust: 132 mm
 Diameter: Ø 180 mm

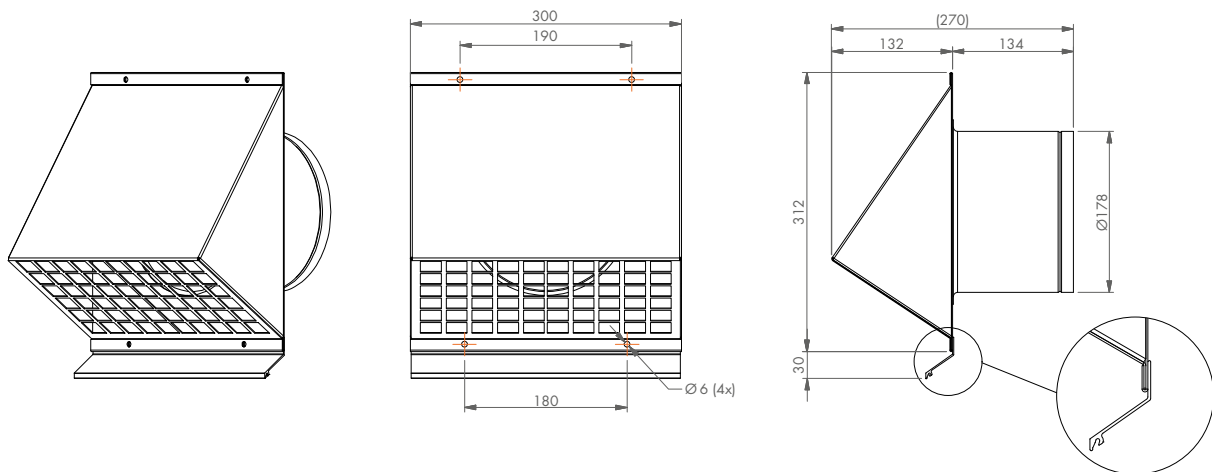

PRESSURE DROP - FLOW

INTAKE	
Q [m³/h]	Δp [Pa]
100	2,5
150	5,4
200	9,4
250	14,3
300	20,2
350	27,1
400	35,0
450	43,8

EXHAUST	
Q [m³/h]	Δp [Pa]
100	0,8
150	1,8
200	3,2
250	4,9
300	6,9
350	9,3
400	12,1
450	15,2

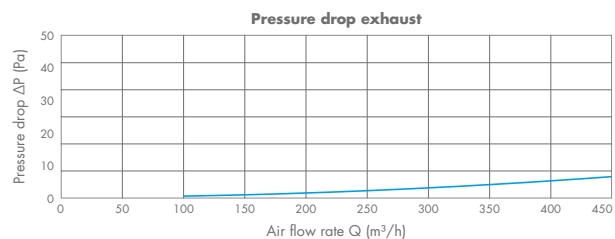
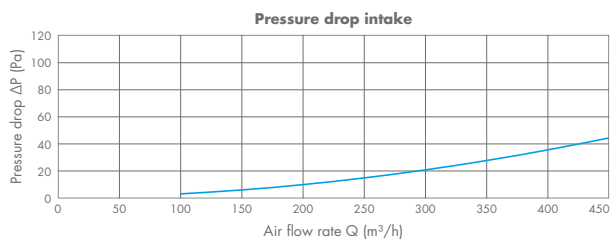

TECHNICAL DATA SHEET:

CO₂ monitor - G0017485

DESCRIPTION

IAQ is a measuring tool for the quality of indoor air, since the comfortable indoor environmental quality keeps people working efficiently, healthy and feeling well.

CO₂-concentration is an important indicator for good quality of indoor air. Therefore the Renson CO₂ monitor can be a useful tool.



PRODUCT CHARACTERISTICS

- Colour: black
- CO₂ measurement range: 0 - 3000 ppm
- Operational temperature: 0 - 50 °C
- Accuracy: 0 - 2000 ppm: ±7%, > 2000 ppm: ±10%
- AC/DC adapter: not included [Battery CO2 monitor G0017585 can be bought separately]
- DC output range: 5 VDC / 300 mA
- 3 LEDs: current Indoor Air Quality [IAQ]
- Communication interface: Windows XP, Windows 7
- USB function
- Data logging:
 - Real time graph: temperature and CO₂
 - History: date, time, temperature and CO₂

PACKAGING

- Art. No.: G0017485
- Dimensions: 116 x 38 x 23,8 mm
- Packaging: per 4 pieces

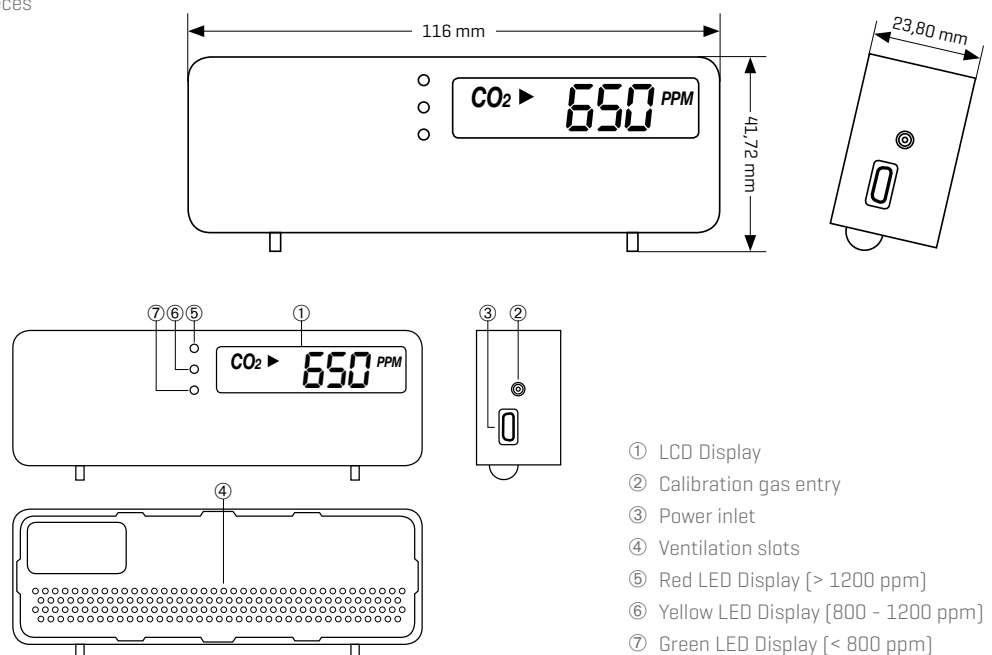

TECHNICAL DATA SHEET:

Battery CO₂ monitor - G0017585

DESCRIPTION

The Renson CO₂ monitor (G0017485) becomes portable thanks to the Battery CO₂ monitor, a handy gadget with which electrical devices can be charged if there is no socket nearby.

The CO₂ monitor can be used longer to measure the Indoor Air Quality (IAQ) on different locations. Moreover, the Battery CO₂ monitor can be used for other purposes as well, such as charging a smartphone or tablet.



PRODUCT CHARACTERISTICS

- Colour: black
- Material: aluminium
- Capacity: 2200 mAh
- Charging time: 2 hours
- Type of battery: Lithium-ion
- Indication of the charging status:
 - red while charging
 - off when fully charged
 - blue when completely depleted
- Output: 5V/1A
- USB connector

PACKAGING

- Art. No.: G0017585
- Dimensions: 93 x 22 x 21 mm
- Packaging: per 18 pieces



RENSON® ACADEMY

Why?

The proper functioning of our products does not only depend on the quality, but also on the correct installation and adjustment by the installer. As manufacturer, we also ensure that these installers deliver good work.

How do we manage this?

Installers receive a thorough technical training at our training centre. Our experienced installers show them how to install everything correctly.

The result?

Properly working systems that ensure the comfort and health of the residents and meet all the technical and quality requirements.

RENSON® PRE- & AFTERSALES

Why?

A specific project? We look for a suitable solution together with you. We can also help you with questions about installation.

How do we manage this?

A team of technically trained employees is ready with a suitable answer to all your questions.

Result?

For every project, there is a suitable solution and an excellent after-sales service.



Get inspired in our showroom
EXIT5 at Waregem along the E17

E X I T 5

EXPERIENCE, INNOVATION & TECHNOLOGY @ RENSON

WE'D BE HAPPY TO HELP YOU!

Our head office - the elegant building designed by the late architect Jo Crepain, which has been the visiting card of our company for many years - is now being renovated. The bottom part of the building now has an imposing glass façade. Behind the façade, there is a new 'Customer Centre' with reception rooms for customers, conference rooms, and an auditorium, where large groups of more than 300 people can participate in presentations. In case of smaller groups, this auditorium can also be divided into 3 separate rooms.

The highlight of the project is the new showroom of 1250 m², where professional customers as well as private individuals can be accommodated. Apart from a showroom for Renson's various innovative solutions and concepts, it is planned to make this room a knowledge centre, where customers can walk in and ask questions about ventilation, heating, sun protection, ventilative cooling, acoustics, interior, etc., In short: everything to provide the home with all the necessary comfort. There is also the possibility to view the solutions in practice in show houses located nearby.

For more information about the network of RENSON ambassadors, please visit our website at: www.renson.eu

RENSON®: YOUR PARTNER IN VENTILATION, SUN PROTECTION AND OUTDOOR

- **Creating healthy spaces**

From 1909, we've been developing energy efficient solutions assuring a healthy and comfortable indoor climate. Our headquarters - built according to the 'Healthy Building Concept' - is a beautiful example portraying our corporate mission.

- **No speed limit on innovation**

A multidisciplinary team of more than 90 R&D employees continually optimize our products and develop new and innovative concepts.

- **Strong in communication**

Contact with the customer is of the utmost importance. A group of 100 in-the-field employees worldwide and a powerful international distribution network are ready to advise you on site. EXIT 5 at Waregem gives you the possibility to experience our products on your own and provides necessary training for installers.

- **A reliable partner in business**

We can guarantee our customers optimal quality and service thanks to our environmentally friendly and modern production sites [with automated powder coating line, anodisation line, uPVC injection molding machinery and mold making shop] covering an area of 95.000 m².



RENSON® Headquarters
Maalbeekstraat 10, IZ 2 Vijverdam, B-8790 Waregem, Belgium
Tel. +32 (0)56 62 71 11
info@renson.eu
www.renson.eu

