

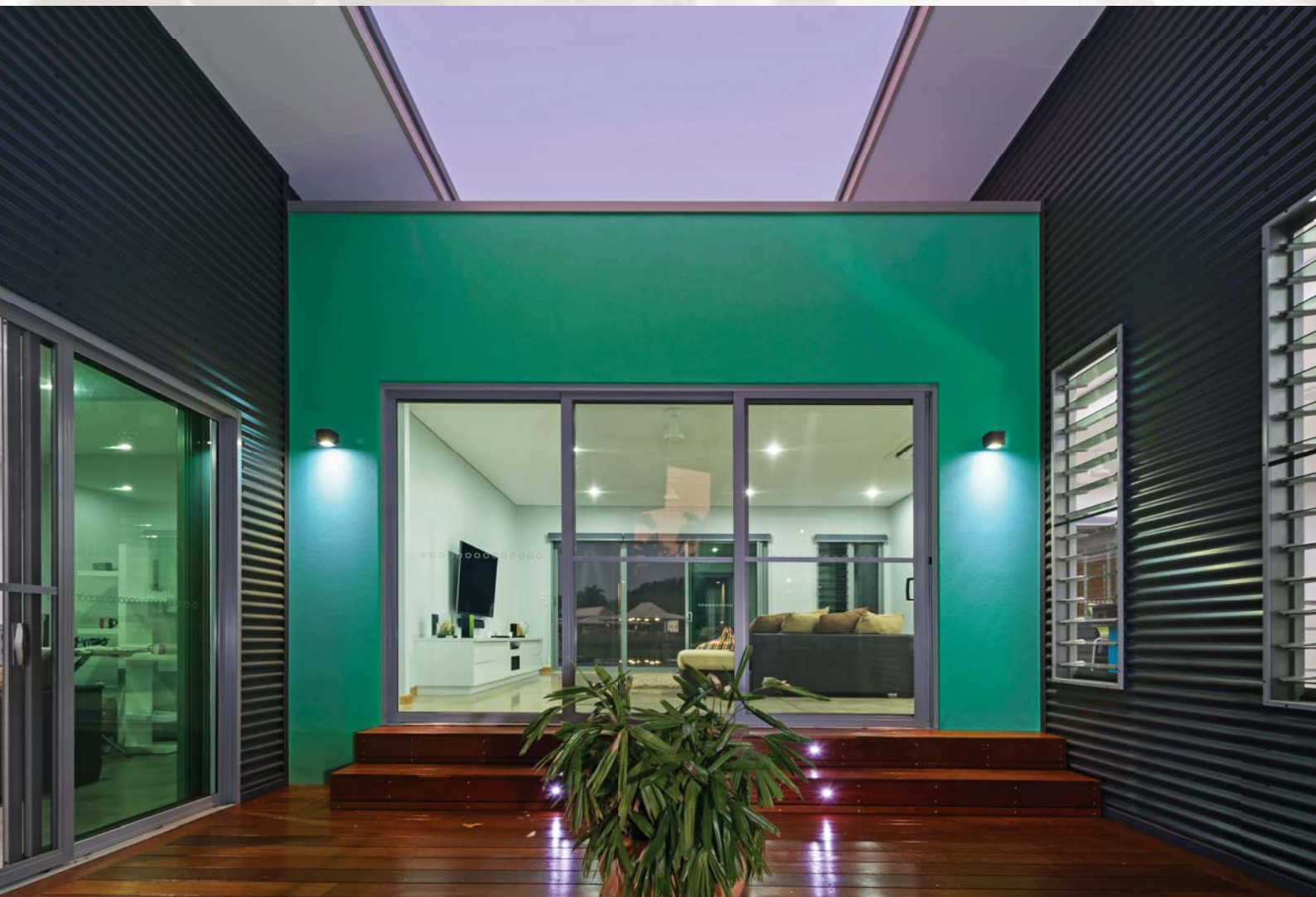

Capral Aluminium Window & Door Configurations

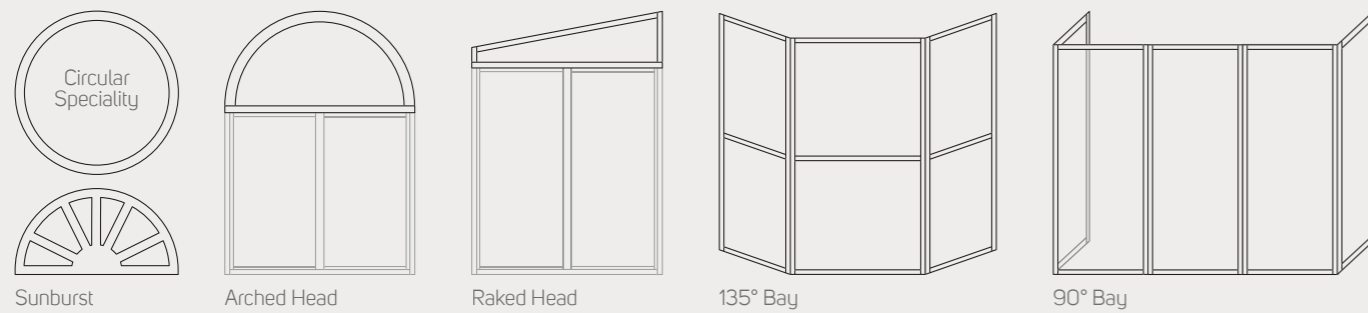

Capral Window Style options

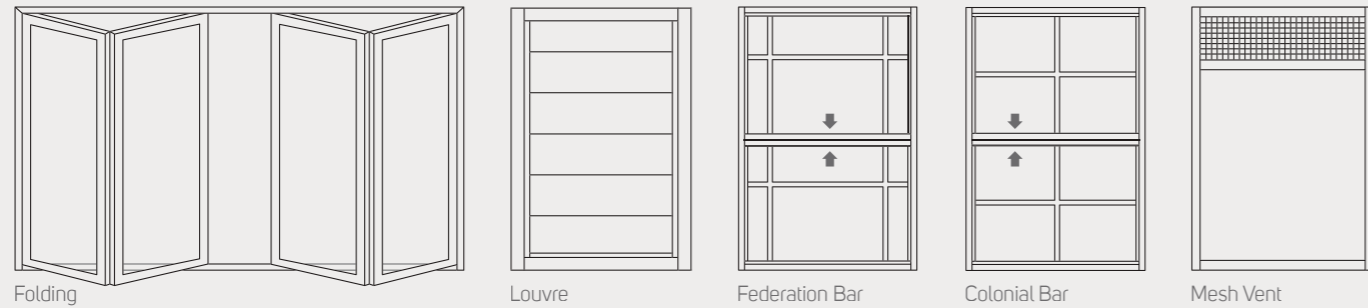
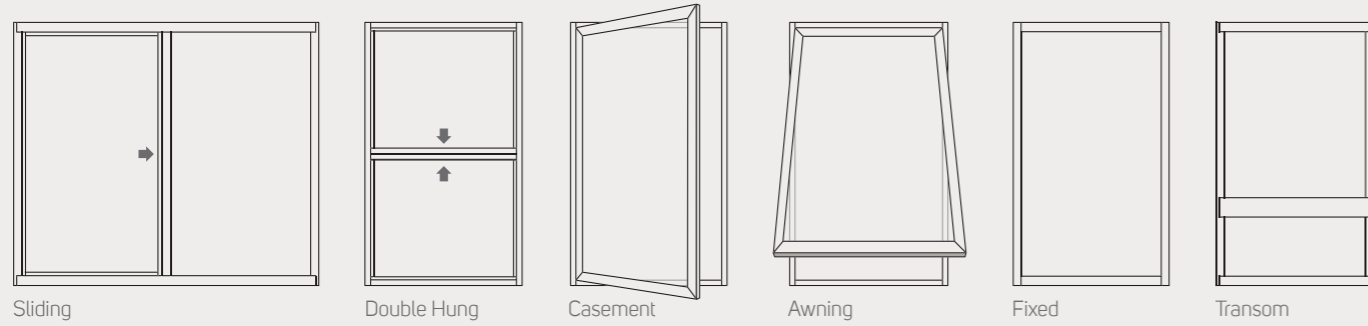

Capral Door Style options

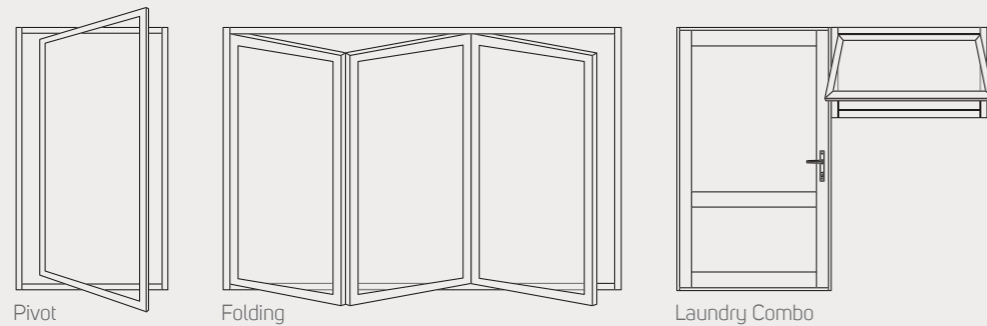
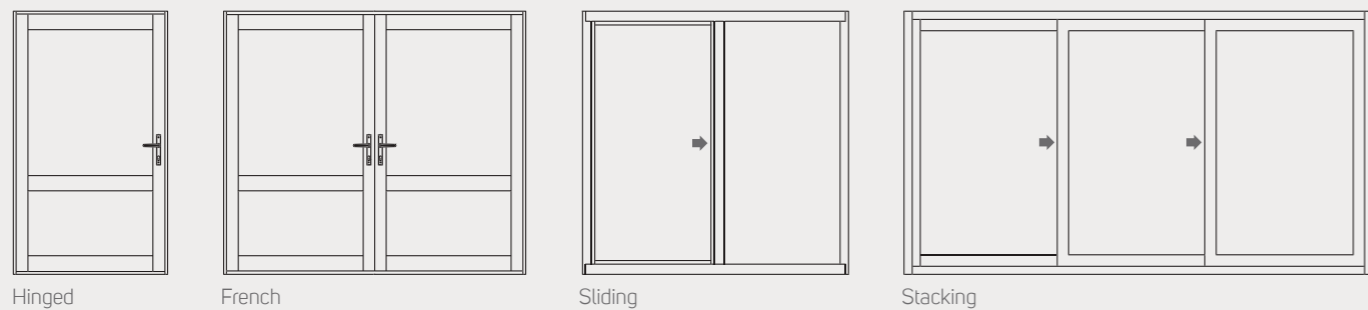

Sliding Windows

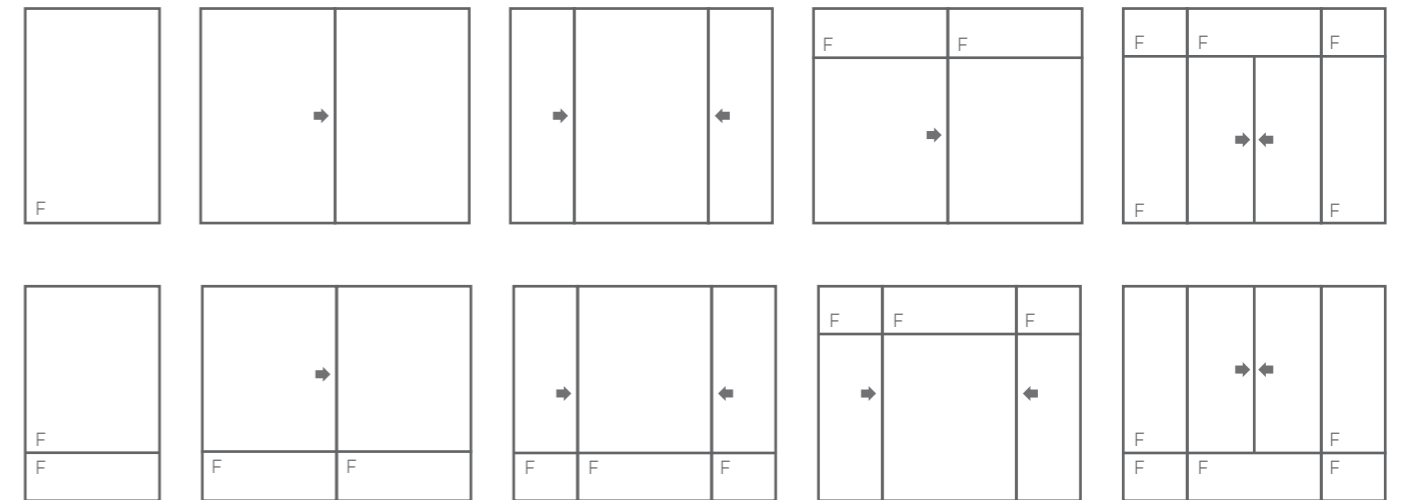

Double Hung Windows

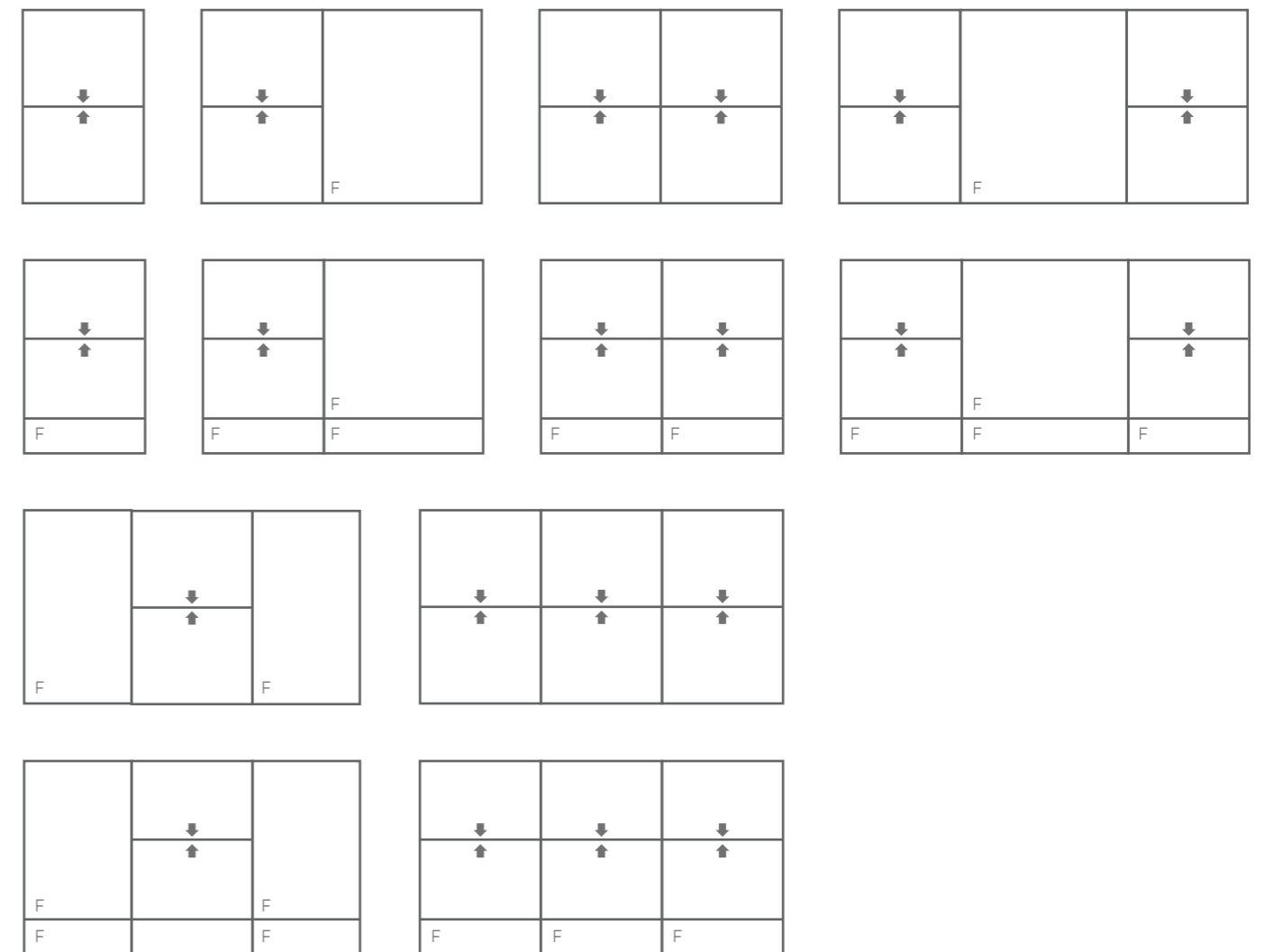

Awning/Casement Windows

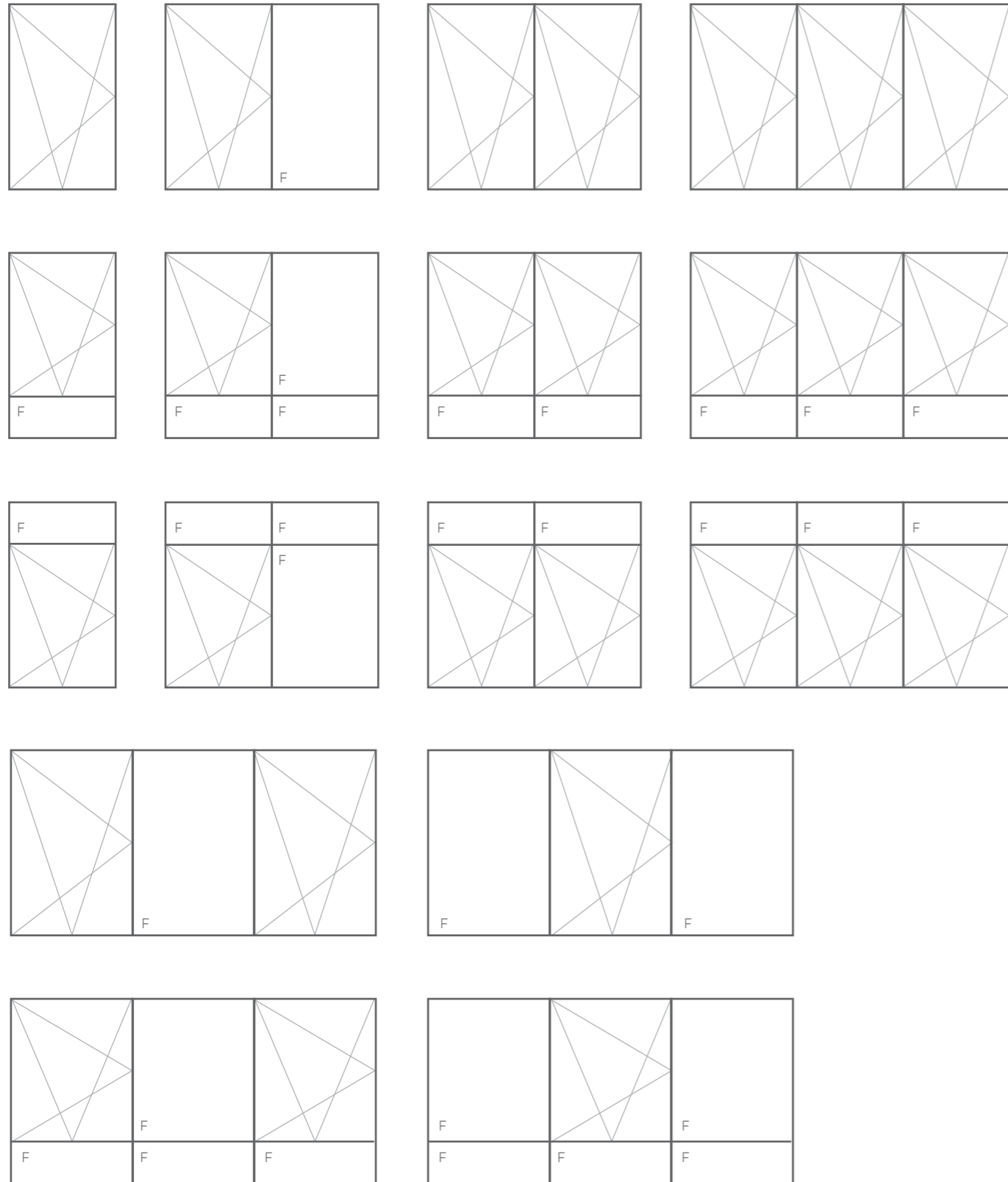

Awning/Casement Windows



Louvre Frames

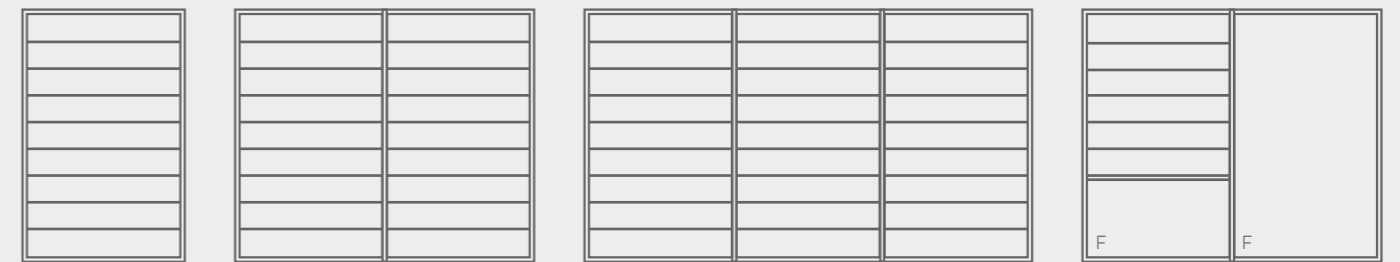

Sliding Doors

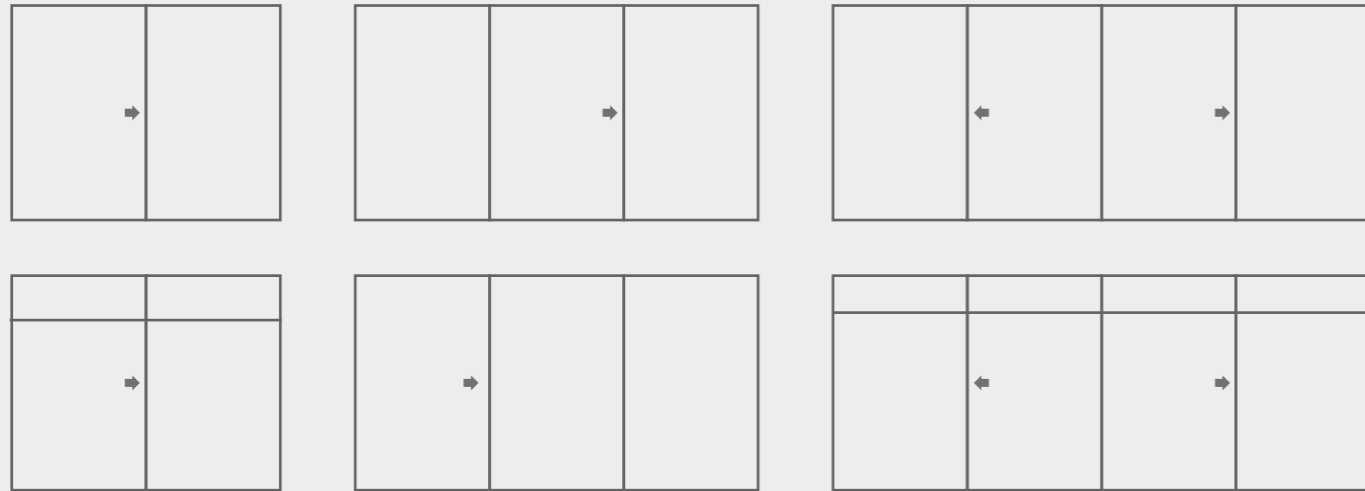

Stacking Door

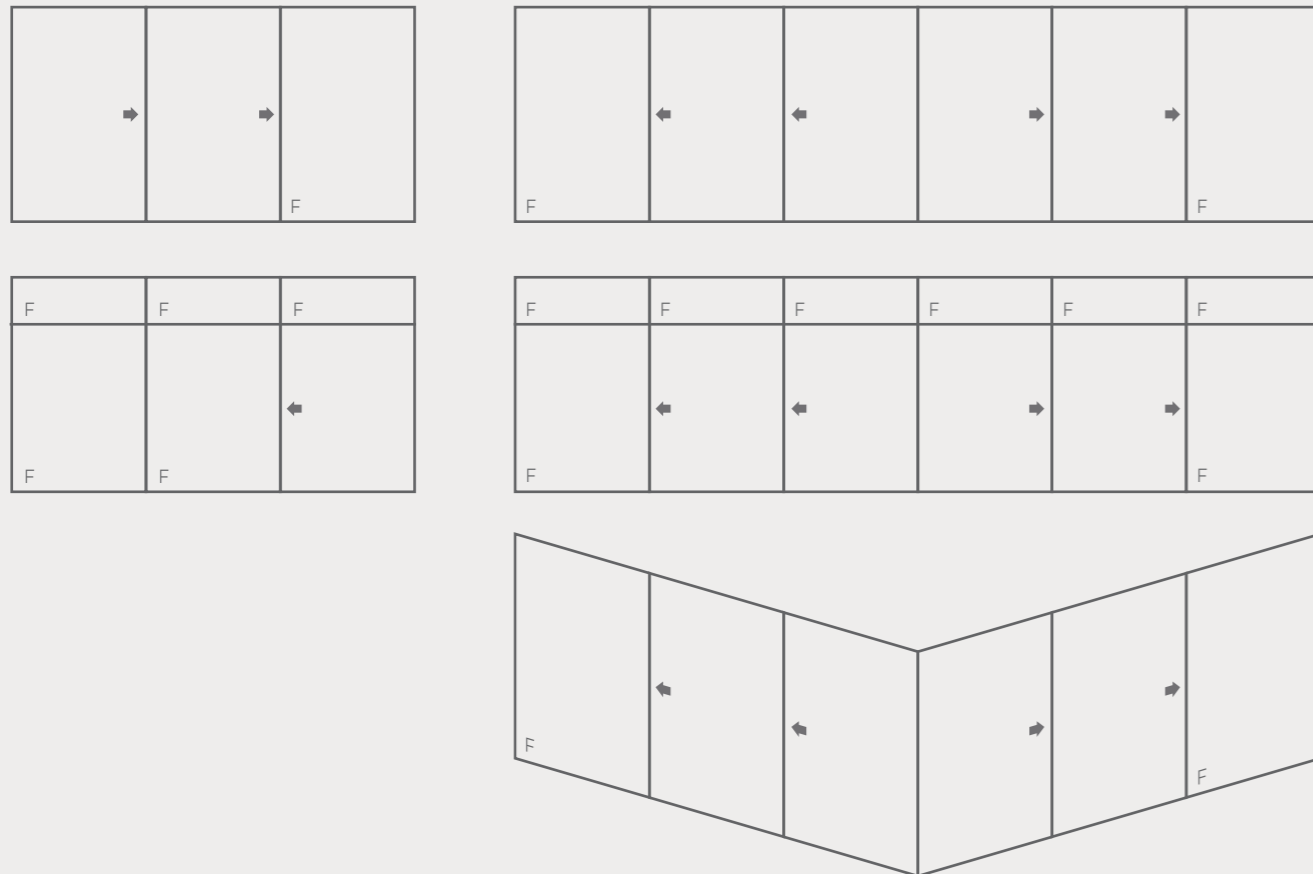

Hinged Doors

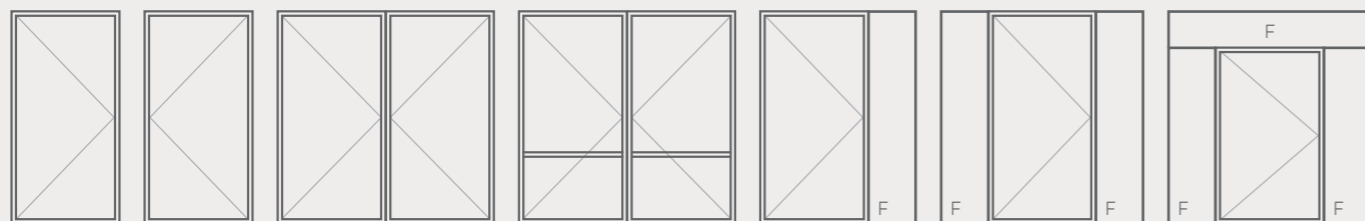

Folding Doors

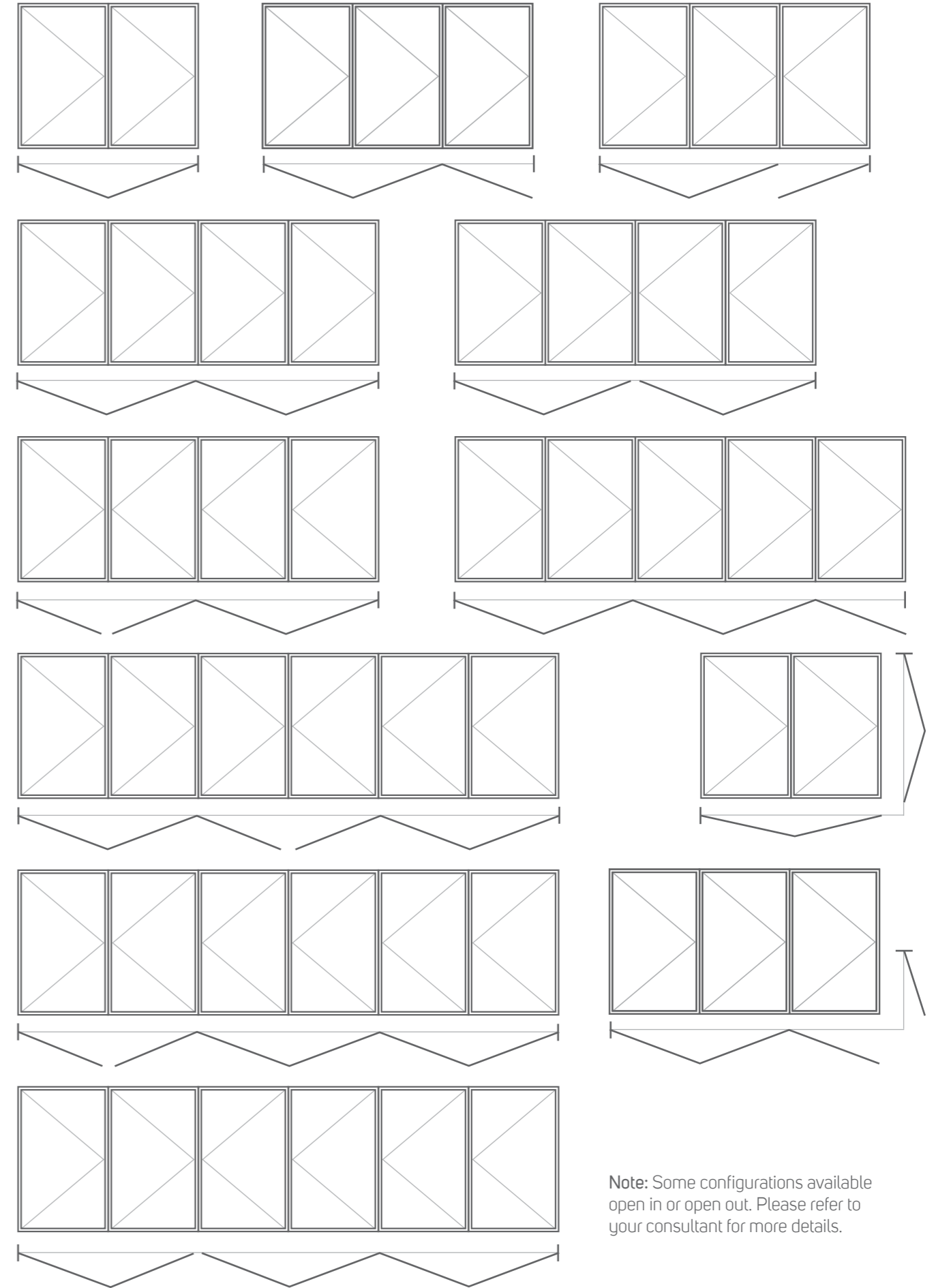

Note: Some configurations available open in or open out. Please refer to your consultant for more details.

Caring for your new Capral Aluminium product correctly should greatly enhance its life, appearance and functionality. Below are some tips that should help to extend the life of your aluminium product.

Caring for your new Capral Aluminium product

Aluminium Windows and Doors

All external aluminium surfaces of windows and doors should be washed with clean water and a mild detergent at least every three months. A soft sponge or similar should be used to avoid scratching the glass or aluminium. In coastal or industrial areas where the environmental conditions are more demanding, the cleaning program should be carried out on a monthly basis.

Abrasive, chemical cleaners or steel wool should not be used as such methods may result in damage to the glass or aluminium surfaces. Drainage slots should be checked on a regular basis to ensure they have not become blocked with residual dirt or grime.

Awning/Casement Windows and French Doors

With sashes open, the sash and opening perimeter should be cleaned regularly and kept clear of dust and foreign matter. All door and window operating hardware should be cleaned and operated regularly to ensure smooth operation. Lubricants should not be used on casement stays, as this will affect their operation.

Double Hung Windows

Window jamb tracks should be cleaned regularly and kept clear of dust and foreign matter. Window operating hardware should be cleaned and operated regularly. It is imperative that both top and bottom sashes are operated fully on a regular basis to ensure smooth operation.

Sliding Windows and Sliding Doors

Sill recesses should be regularly cleaned and kept clear of dust and foreign matter. A brush and vacuum within the track area may be used to do this. Door locks should be checked from time to time for satisfactory operation and may require adjustment to compensate for building settlement.

Door rollers are factory set and should not require any adjustment. However, if due to building settlement, an adjustment needs to be made, the door panel must first be lifted to relieve weight from the roller assembly. Adjustment should be made using a Phillips head screwdriver.

Insect and Safety Screens

- Flyscreens can be cleaned by vacuuming or washing thoroughly using a soft brush.
- Clean screens 3 to 4 times per year.
- Add a small amount of mild detergent to a bucket of warm water.
- Carefully remove the screen.
- Hose the screen down thoroughly.
- Dip a soft nylon brush into the bucket of water and gently brush the screen.
- Hose down well.
- Allow the screen to dry before replacing.

Hardware

Regular maintenance is required for all hardware, even stainless steel components, as they are moving parts. In most environments, maintenance is recommended every six (6) months and every three (3) months in marine and industrial environments.

Hangers, pivots and brackets should be given a light spray of corrosion preventative silicone based spray (such as CRC Marine 66 or Innox) followed by a light wipe with a dry cloth to remove excess. Exposed surfaces should be wiped down with warm soapy water and a soft rag and then rinsed clean before applying preventative. Visible surfaces of hinges should be wiped down with warm soapy water on a soft rag and then rinsed off by wiping with a clean damp rag. Application of a thin film of light machine oil or one of the corrosion preventative sprays mentioned above will help to maintain the original lustre of the metal finish. Be careful not to get these compounds on the timber work itself as they may cause staining.

Drop bolts should be sprayed with a lubricant such as those mentioned above and the sliding pin inside the bolt and to the lock cylinder.

Maintenance Tip:

Abrasive-type cleaning agents (Ajax or similar) or other abrasive cleaning materials such as steel wool or the like, can severely damage aluminium surfaces and should be avoided.

Glass

It is recommended that all glass surfaces be kept clean by prompt removal of all dirt or other contaminants. Clean water and, in some instances, a small amount of mild detergent should be used. After washing, any detergent residue must be thoroughly rinsed away with clean water.

Under no circumstances is any form of blade, scraper or abrasive cleaner to be used. Stubborn dirt or residue should be lightly sponged off to avoid scratching of the glass.

The frequency of cleaning required will depend on environmental conditions such as proximity to the ocean or industrial areas. As a general guide, glass should be cleaned at least quarterly.



Capral window and door installation information

General notes

Before installation

- Check the window or door label to ensure that the window has the appropriate 'N' rating (strength/water resistance) for the installation location.
- Lift all windows and doors carefully from trucks or other transport mechanisms. Do not use slings.
- When handling or transporting windows or doors, carry the product in a vertical position from the bottom of the product. Window sashes must be closed and in a locked position.
- Avoid knocking or damaging the product in any way.
- Stack the product carefully on edge to avoid damage to the powder coat or like finishes.
- Stack windows and doors in a dry place and cover the product to protect against pane, dust or weather damage and/or exposure.

During installation

- Ensure that there is sufficient clearance around the perimeter of the frame before attempting to install a window or a door. If the wall condition is not shown, please contact your local fabricator or Capral for the appropriate technical advice.
- Once the clearance is established, ensure the aluminium frame is insulated from contact with other metals to avoid potential future corrosion of the aluminium. This could be by a bitumen coating of any steelwork around the window or door, or the application of flashing membranes.
- When installing the product, please note that it is important not to distort the window or door frame by forcing it open in any way.
- Please note that windows and doors are non-load bearing and an allowance of 12mm from the underside of the sill brick or tile is required to allow for building settlement.
- The sill must be straight and level at all times. Plumb jamps in both directions and pack the frame at the sill and jamps only. Please see illustration above right.

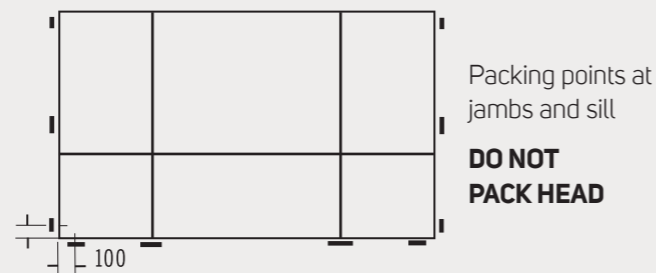

- The frame must be square and out of twist which is essential for the smooth operation of the sashes.
- Check that the diagonal measurements are equal. Clearance must be maintained between the fill brick or tiles and the window or door frame.
- Ensure that all flashings are correctly fitted.
- Do not stand on or place any loads on the sill or any other part of the frame. Do not use as a support scaffolding or slide material through the frames.
- Before the sliding panels (if applicable) are inserted, the tracks should be cleaned thoroughly to remove all dirt and other substances.

Please Note: Aluminium window and door frames should not come into direct contact with bricks, concrete brickwork or cement rendered surfaces as in some cases this may result in corrosion.

After installation

- Protect windows and doors from damage during the construction process.
- If plastic wrap has been provided, **do not remove** it until the brickwork is complete.
- If the window or door comes into contact with cement, mortar, paint acids or any other substance, **wash it off immediately.**
- Use soft cloths to clean and avoid scratching the surface.
- Do not scrape tools or anything else on the window or door frame.
- Clean the windows and doors with warm soapy water or a mild detergent and rinse with clean water.
- Ensure that the drainage spots on the aluminium frames are not blocked.

Windows

Brick Veneer Construction

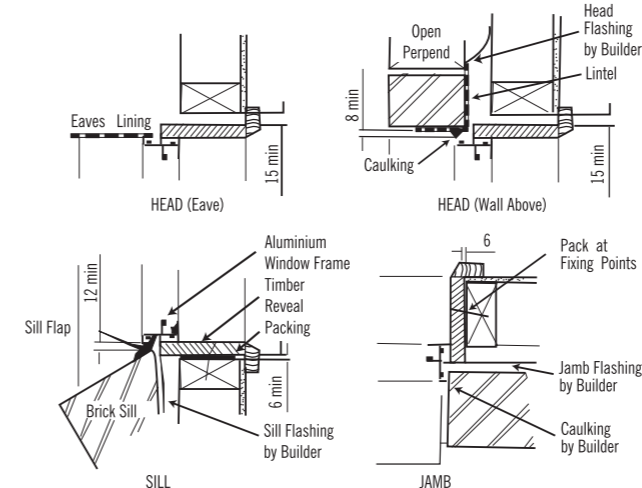

Sliding Doors

Brick Veneer Construction

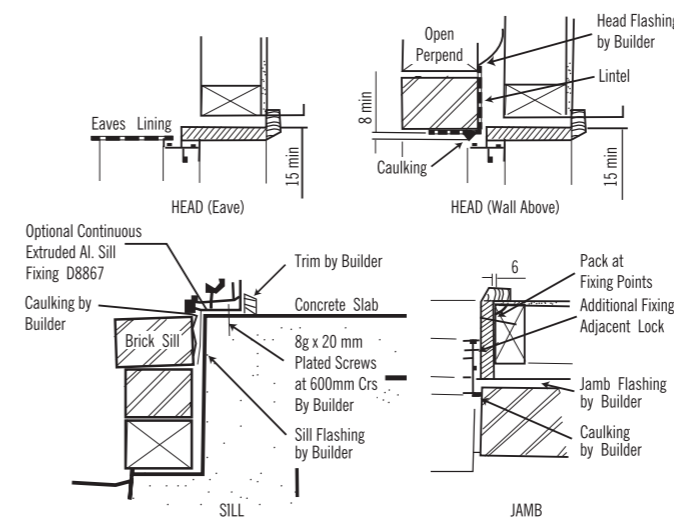

French and Hinged Doors

Brick Veneer Construction

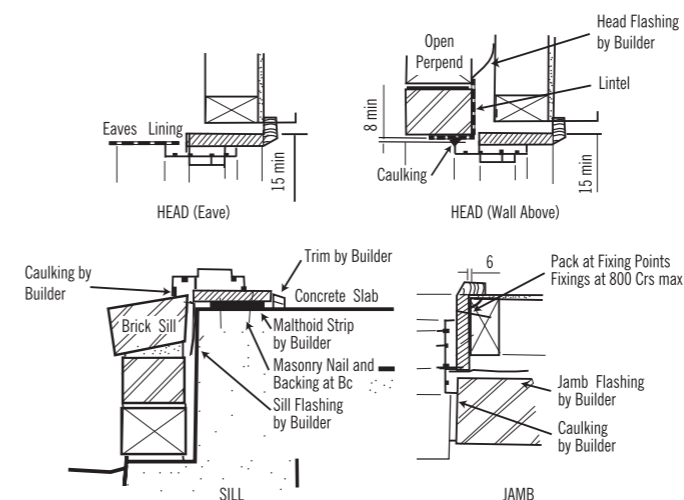

Weatherboard Construction

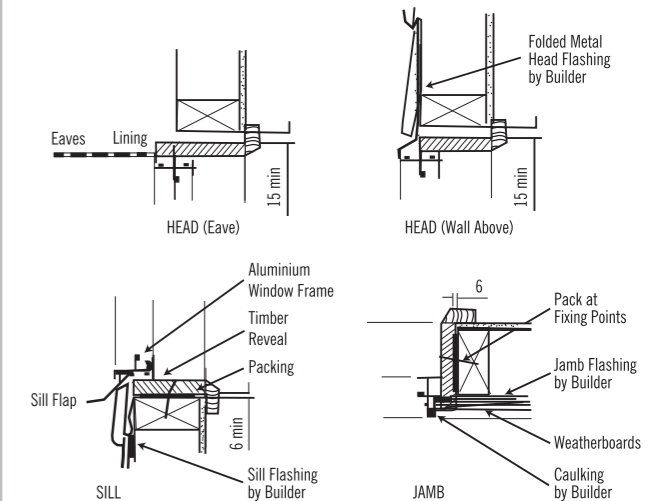

Weatherboard Construction

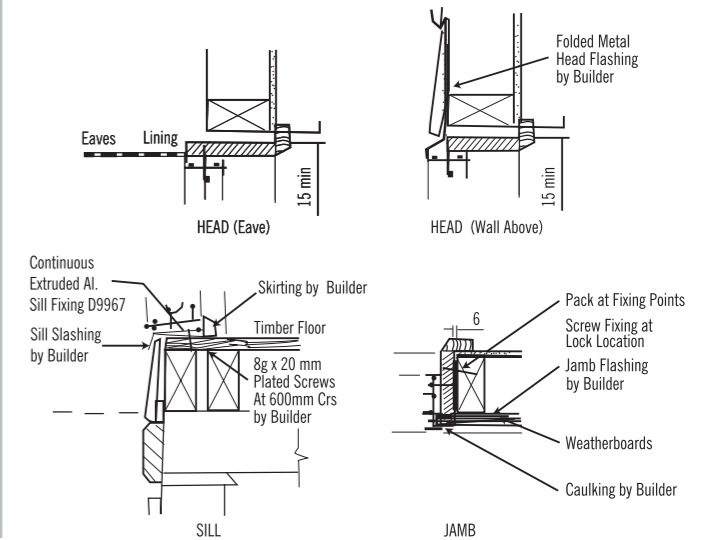

Weatherboard Construction

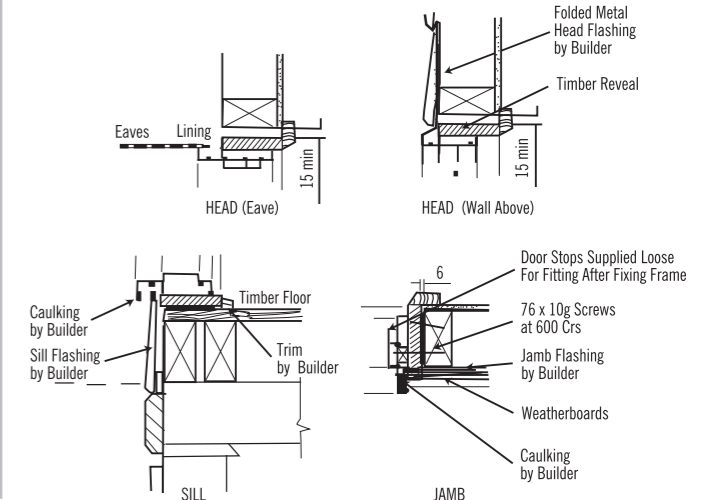



Download the Capral Hub App
for all the latest aluminium
window and door product data.

1800 ALUMINIUM (258 646)
www.capral.com.au
Capral Limited ABN 78 004 213 692 | May 2017