

JUNE 2021

**LIGHT COMMERCIAL  
& RESIDENTIAL STEEL  
FRAMED BUILDINGS**

**DURAGRID™**  
FACADE SYSTEMS



**BGC** | Fibre Cement

[WWW.BGCINNOVADESIGN.COM.AU](http://WWW.BGCINNOVADESIGN.COM.AU)

## INNOVA™

BGC'S STUNNING RANGE OF FACADE, LINING AND FLOORING PRODUCTS, INNOVA™ WILL MOVE YOU TO REASSESS YOUR CONCEPT OF EXCELLENCE IN FACADES AND FLOORING SYSTEMS. DURABLE AND DYNAMIC, FRESH AND CONTEMPORARY, INNOVA™ IS ALREADY TURNING INDUSTRY HEADS. NOW LET THE INNOVA™ RANGE OF CLADDING AND FLOORING PRODUCTS BREATHE NEW LIFE INTO YOUR CREATIVITY AND PROJECT SPECIFICATION.



---

THE DURAGRID™ FACADE SYSTEM UTILISES BGC FIBRE CEMENT SHEETING, OFFERING THE IDEAL SOLUTION FOR CLADDING THE EXTERIOR OF LOW TO MEDIUM RISE BUILDINGS. DURAGRID™ GIVES BUILDINGS A MODERN AND EXTREMELY DURABLE FINISH.

---

DURAGRID™ SHEETING HAS A SMOOTH, FLAT SURFACE AND SQUARE EDGE FINISH WHICH IS SUITABLE FOR EXPRESSED JOINTING AND PROVIDES A FACADE SUITABLE FOR A NUMBER OF FINISHES - FROM PAINTED TO TEXTURED COATINGS.

#### THE DURAGRID™ FACADE SYSTEM:

- / IS LIGHTWEIGHT
- / IS HIGHLY DURABLE
- / PANELS WILL NOT ROT, BURN OR CORRODE
- / PANELS ARE NOT AFFECTED BY TERMITES, AIR, STEAM, SALT OR SUNLIGHT
- / CAN BE EASILY DECORATED IN A NUMBER OF DESIGN FINISHES
- / QUICK AND SIMPLE TO INSTALL USING SCREW FIXING





# CONTENTS

APPLICATIONS	/ 5
ADVANTAGES	/ 5
ENERGY EFFICIENCY CONSIDERATIONS	/ 5
PRODUCT INFORMATION	/ 5
SHEET TOLERANCES	/ 5
THERMAL BREAKS	/ 5
FIRE RESISTANCE	/ 5
DURABILITY	/ 5
THERMAL CONDUCTIVITY	/ 5
PANEL SIZES AND MASS	/ 5
HANDLING AND STORAGE	/ 6
COASTAL AREAS	/ 6
DURAGRID™ ACCESSORIES AVAILABLE FROM BGC	/ 6
FASTENERS	/ 6-7
DESIGN CONSIDERATIONS	/ 7
CONTROL JOINTS	/ 7
GROUND CLEARANCE	/ 7
PANEL PREPARATION	/ 8
BACKING STRIP INSTALLATION & SEALING	/ 8
FASTENER SPACING - LIGHT COMMERCIAL	/ 9
BATTEN SPAN / WIND PRESSURE LOAD	/ 9
FRAMING	/ 9
DURABATTEN INSTALLATION	/ 10
BATTEN JOINING	/ 10
INSTALLATION DETAILS	/ 10-14
PENETRATIONS, WINDOW & DOOR OPENINGS	/ 15-16
WARRANTY	/ 17

## APPLICATIONS

Duragrid™ Facade System utilises BGC Fibre Cement panels and graded, primed timber or steel battens to form a strong and durable facade cladding system.

Duragrid™ is ideally suited for versatile architectural applications in light commercial applications where high impact resistance is not required. If high impact resistance is required BGC recommend the use of the Duracom™ compressed fibre cement facade system.

Duragrid™ panels are designed for installation in a variety of patterns, including vertical, horizontal, and brick-bond.

Duragrid™ panels are available in 9mm thickness and may be finished with site applied acrylic paint systems or a factory applied high quality polyurethane plain finish. These may need alternative fixing methods. Please contact your local BGC office for advice.

NOTE: The fitting of the Duragrid™ Facade System should only be attempted by a professional contractor. Your local BGC Fibre Cement office can provide you with a list of recommended Duragrid™ installers.

## ADVANTAGES

- / Lightweight cladding system
- / Readily accepts many forms of decorative finish
- / Highly durable product
- / Dynamic architectural style
- / Face sealed for paint application

## PRODUCT INFORMATION

Duragrid™ panels are an autoclaved, cellulose fibre reinforced silica/cement panel, specially formulated and prepared to meet the requirements for use in exterior applications. Duragrid™ panels have a smooth flat surface and a neat square edged finish, for enhanced expressed joint facades.

BGC Fibre Cement products are manufactured to the Australian / New Zealand Standard AS/NZS 2908.2-2000 Cellulose-Cement Products, Part 2: Flat sheets and Duragrid™ is classified as Type A-Category 3.

## SHEET TOLERANCES

Duragrid™ complies with the requirements of AS2908.2.

## THERMAL BREAKS

The Duragrid™ facade system is attached to the outside face of a metal framed wall where it is separated from the metal frame by Duragrid™ Steel Top Hats (off-stud) orientated vertically.

Where the lightweight external cladding is not fixed to the metal frame, the NCC thermal break requirements are negated therefore no Thermal Break is required when using the Duragrid™ facade system.

## FIRE RESISTANCE

BGC Fibre Cement 9mm has been tested for and passed the Early Fire Hazard Property criteria in compliance with AS/NZS 1530.3 and AS/NZS 3837 and is deemed a Group 1 Material in accordance with the Building Code of Australia (BCA), Volume 1, Specification A2.4; Fire Hazard Properties. AS/NZS 1530.3; Early Fire Hazard Properties.

/ Ignition Index	0
/ Spread of Flame Index	0
/ Heat Evolved Index	0
/ Smoke Developed Index	0-1

## DURABILITY

Duragrid™ physical properties ensure it's durability in exposed applications.

- / Duragrid™ panels are immune to permanent water damage in both short and long-term exposure.
- / Duragrid™ panels will not rot or burn and are unaffected by termites, air, steam, salt and sunlight.
- / Duragrid™ panels are not adversely affected over a temperature range of 0°C to 95°C.

Vapour permeable sarking must be installed under the timber or steel batten in accordance with the AS/NZS 4200.2 – 'Pliable building membranes and underlays – Installation' and the sarking manufacturer's guidelines. The sarking should have the following properties:

- / Vapour barrier – low or medium
- / Water barrier – high

Vapour permeable sarking is used to prevent moisture ingress by acting as a drainage plane whilst enabling water vapour build up from inside the frame space.

To ensure the durability of the Durabatten apply a film of polyurethane over the exposed face at the expressed joint.

## THERMAL CONDUCTIVITY

Duragrid™ panels have relatively low thermal conductivity: R-value. At Equilibrium Moisture content the approximate R-Value of Duragrid™ is; - 0.55 W/m°C.

## WEATHER RESISTANCE / FREEZE THAW

The Duragrid™ Facade System conforms to the Building Code of Australia (BCA) requirements for external wall applications. Duragrid™ Facade System has been tested to AS/NZS 4284 Testing of Building Facades.

Duragrid™ subject to freeze/thaw conditions must be painted. Duragrid™ should not be used in situations where it will be in direct contact with snow or ice for prolonged periods.

## SHEET SIZES AND WEIGHT

Duragrid™ panels are available in the following sizes.

THICKNESS mm	MASS KG/M <sup>2</sup>	WIDTH mm	LENGTH mm			
			1190	1790	2390	2990
9	13.5	590			✓	
		890		✓		
		1190	✓			✓

## HANDLING AND STORAGE

Duragrid™ must be stacked flat, up off the ground and supported on equally spaced (max 400mm) level gluts. Care should be taken to avoid damage to the ends, edges and surfaces.

Sheets must be kept dry. When stored outdoors it must be protected from the weather. Sheets must be dry prior to fixing, jointing or finishing.

## COASTAL AREAS

The durability of galvanised nails and screws used for exterior cladding in coastal or similar corrosive environments, including very heavy industrial areas can be as low as 10 years.

For this reason BGC recommend the use of Stainless Steel fasteners within 1km of the coast or other large expanses of salt water.

## ACCESSORIES AVAILABLE FROM BGC

DURABATTEN - STEEL	35 x 70 x 3000mm	BGC Product Code 496	
	19 x 70 x 3000mm	BGC Product Code 495	
HORIZONTAL BACKING STRIP	1190mm	BGC Product Code 839	
	2390mm	BGC Product Code 841	
	2990mm	BGC Product Code 843	
CAVITY VENT STRIP	19 x 2700mm	BGC Product Code 480	
SEALANT / ADHESIVE	Sikaflex 300ml 11FC or similar	BGC Product Code 485	
	Sikaflex 600ml 11FC or similar	BGC Product Code 486	
COUNTERSINKER	Countersinking Tool	BGC Product Code 855	

## FASTENERS

### DURABATTEN TO FRAME

#### DURABATTEN TIMBER TO STEEL FRAME

Builders Class 3, 8 x 35mm Wingtek Self Embedding Head Screw, 8 x 40mm Wingtek Self Embedding Head Screw



#### DURABATTEN STEEL TO STEEL FRAME

Class 3 Hex Head Screw, 12-14 x 20mm



#### DURABATTEN TIMBER TO TIMBER FRAME

Class 3 Corrosion resistant Ring Shank Nail – 2.8 x 65mm



### DURAGRID™ TO DURABATTEN

#### DURAGRID™ TO DURABATTEN STEEL

No.8 x 30mm Countersunk Self Drilling



#### DURAGRID™ DURABATTEN TIMBER

C25 304 Stainless Steel Brads



2.8 x 30mm Fibre Cement Nail



8 x 10 x 25mm Class 3 Countersunk Wood Screw





## FASTENERS

Select fasteners with suitable durability for the prevailing conditions. Please consult your supplier for:

- / Minimum requirements Class 3.
- / Stainless Steel may be required in some applications.

All screw holes must be filled with an epoxy filler such as Megapoxy P1, Hilti CA125 or Hilti CA273 and sanded flush to provide a flat surface for finish coating. When sanding, only sand the screw holes, not the entire sheet surface.

### FIGURE 1 / PRE COUNTERSINK

When using screws to fasten Duragrid™, pre countersinking is required so that the fastener is 2mm under the sheet surface for filling with epoxy filler and then finished with BGC Exterior and Wet Area Top Coat.



## DESIGN CONSIDERATIONS

The designer should determine the wind pressure for the project and specify the layout, spacing and fixing of the Durabatten to the structure.

The deflection of the supporting structure should be limited to span/250 for Serviceability Wind Load, or as limited by AS/NZS1170.

In areas where there is a probability of wind loading, care should be taken in the design detailing, especially around all openings, corners and other junctions, to ensure the weather resistance of the total system.

Before the Duragrid™ panels and the supporting substructure is installed and fixed, particular care should be taken that all flashing and waterproofing work is complete, including all vapour permeable building wraps and damp proof coursing.

## CONTROL JOINTS

In many cases, control joints will not be required as typical expressed joints permit some differential movement of the Duragrid™ panels and the sub-framing.

It is recommended that the designer consider the need for control joints in the following cases:

- / At a change in the structural substrate; eg masonry to steel framing.
- / Where Duragrid™ crosses a building control joint.
- / Where there is likelihood of movement in the sub-framing.
- / Continuous lengths greater than 8 metres.

Structural movement vertical and horizontal control joints are required to match existing structural control joints and should continue through the facade.

## GROUND CLEARANCE

### FIGURE 2 / GROUND CLEARANCE & FOUNDATION DETAIL

Maintain a minimum 150mm clearance to earth or as required by local building regulations.

BGC Interior Liningboard

Steel Durabatten

Duragrid™

UPVC Cavity Closer

Damp Course

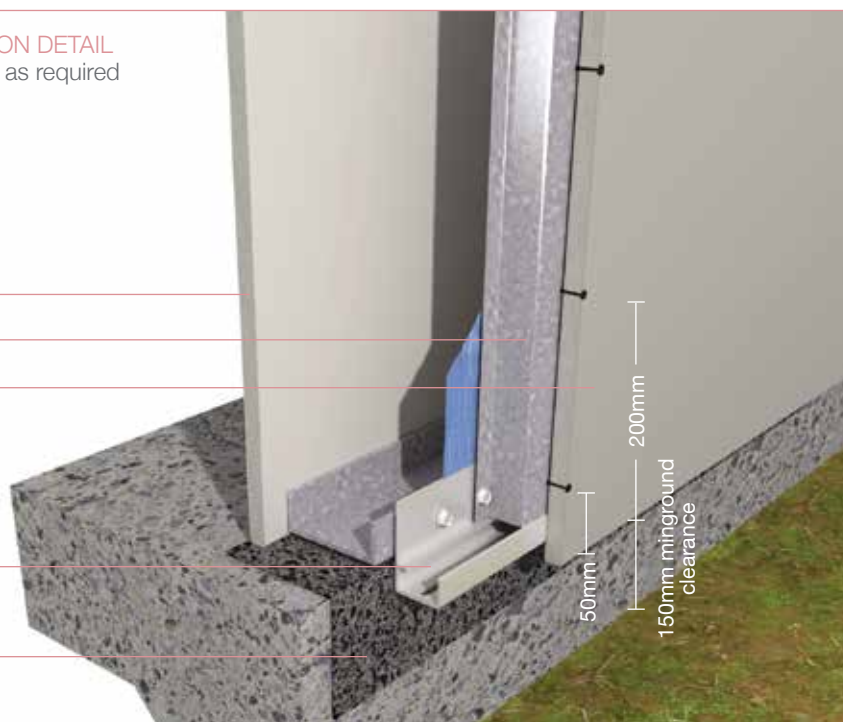

## PANEL PREPARATION

For insitu paint finish applications, Duragrid™ panels are supplied sealed with a proprietary sealer applied during manufacture for durability.

Where it is necessary to cut sheets, cutting tools should have a dust extraction system.

Cut edges must be sealed with BGC Edge Sealer or an acrylic coating to eliminate moisture absorption.

A saw blade such as BGC Durablade with a poly crystalline diamond tip specifically designed to cut fibre cement sheets is recommended.

Ensure work area is well ventilated and wear an approved dust mask (AS/NZS1715 and AS/NZS1716) and safety glasses (AS/NZS1337).



FIGURE 4 / BACKING STRIP TAPE - FRONT VIEW

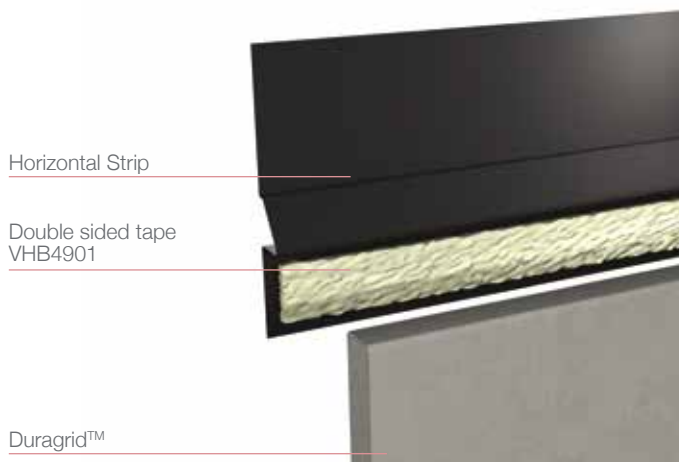

## BACKING STRIP INSTALLATION & SEALING

At the horizontal joints between the Duragrid™ panels, the Horizontal Backing Strip should be bonded to the back of the Duragrid™ panel to form a socket to which the Duragrid™ panels above are fixed over.

Set the backing strip 2mm from the edge of the Duragrid™ panel. Seal the cut edge with BGC Edge Sealer.

The backing strip can be fixed using:

- / Sikaflex 11FC. **Ensure that the sealant has cured fully before panel installation.**
- / 3M 12.7mm VHB4991 or 3M VHB4941 double sided tape. The contact surfaces to be cleaned with 3M HIPA 300 Adhesive cleaner.

NOTE: Sikaflex 11FC is the preferred option for fixing the backing strip.

NOTE: Ensure the sealant fills the void in the back of the Horizontal Backing Strip to prevent moisture ingress.

FIGURE 5 / BACKING STRIP INSTALLATION - REAR VIEW

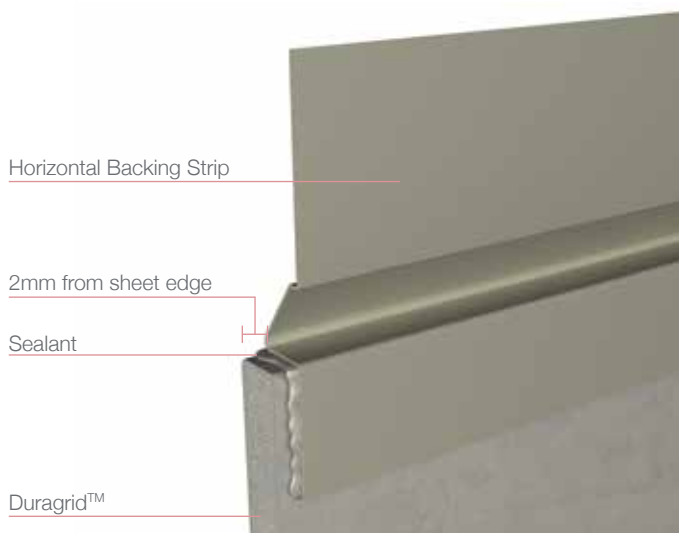
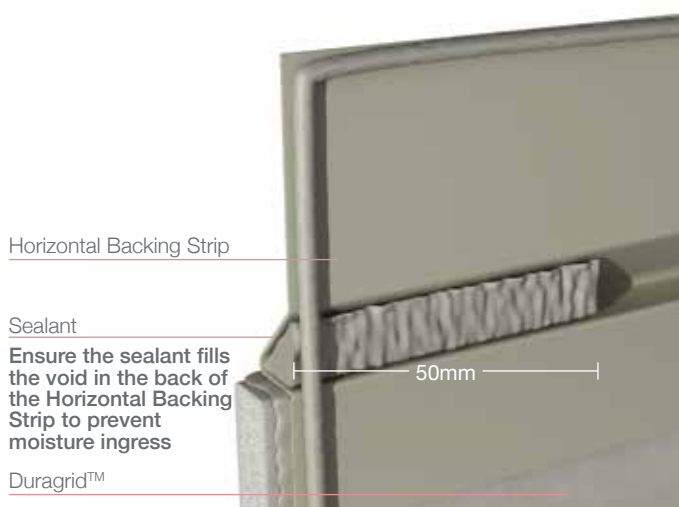

FIGURE 3 / SEALANT (Preferred Option for Optimal Adhesion and Sealing) - FRONT VIEW



FIGURE 6 / BACKING STRIP SEALANT - REAR VIEW





## FASTENER SPACING - LIGHT COMMERCIAL

### FIXING DURAGRID™ TO STEEL BATTENS

Fix cladding to steel batten via a continuous 6mm bead of Sikaflex 11FC polyurethane sealant/adhesive to all contact surfaces and N° 8 x 30mm Countersunk Self Drilling along all support edges, refer to Duragrid™ design table for maximum fixing centres.

### FIXING STEEL BATTENS TO STEEL WALL FRAMES

Steel battens to be 0.75mm BMT and grade 300 steel:

#### BATTEN SIZE:

N1-N3, C1: TH19x70x0.75 batten

C2-C3: TH35 x70x0.75 batten

Steel battens can only be installed OFF stud (batten fixed to noggin) due to the profile of the steel batten.

Maximum batten span, (i.e. noggin spacing), is to be as per Duragrid™ design tables.

Batten spans (i.e. noggin spacing) should be approximately equal (within 25%)

Fix steel batten to steel wall frames with:

N1-N3: (max 1.215kN pullout load)

Fix steel battens to noggins with: Class 3 Hex Head Screws.

C1-C2: (max 1.81kN pullout load)

Fix steel battens to noggins with: Class 3 Hex Head Screw.

Alternatively, steel battens may be fixed to timber wall frames by substituting 8- 18 x 20mm Tek Screws with 8-15 x 40mm screws.

### FIXING STEEL NOGGINS TO STEEL STUDS

Where noggins support battens, noggins must be securely fixed to studs.

Noggins should not span more than 600mm.

Noggins to be fixed to studs via one of the following:

-Minimum 30mm weld each end, evenly spread over both sides of stud.

-2N° 6 x 20 Wafer Head Tek Screws each end of noggin.

-2N° Henrob Rivets or equivalent each end of noggin.

#### NOTES

All calculations include full internal pressurization as per AS4055. Stack bond (no overlap).

Deflection of battens limited to a maximum of span of 200mm.

All steel framed walls to be constructed to relevant standard.

## FRAMING

Ensure that the frame is square and work from a central datum line. The frame must be straight and true to provide a flush face to receive the panels.

BGC recommend a maximum tolerance of 3mm-4mm in any 3000mm length of frame. Duragrid™ will not straighten excessively warped or distorted frames and any warping may still be visible after Duragrid™ is applied. Warped framing will require remedial action.

FIGURE 7 / FRAME STRAIGHTNESS



The steel Durabatten should be fixed off stud – Refer to Span Table. Off stud fixing is restricted to low wind areas and noggins are required at maximum 800mm centres – Refer to Span Table in all instances.

The vertical expressed joints must coincide with the centre line of the Durabatten. Stud centres may have to be designed to facilitate express joints.

#### STEEL FRAME

Use of steel frame must be in accordance with AS4600 – Cold Formed Steel Structures and the framing manufacturer's specifications.

Framing members must have a Base Metal Thickness (BMT) between 0.55 to 1.6mm. The steel framing must have the appropriate level of durability required to prevent corrosion.

Stud framing members must be a minimum of 64 x 35mm.

## BATTEN SPAN/WIND PRESSURE LOAD

AS4055 Wind Classification	Stud & Durabatten Spacing (mm)	TH19x70x0.75 Batten Span (max)	TH35x70x0.75 Batten Span (max)	Duragrid™ Fixing Centres
Non Cyclonic				
N1, N2, N3	600	900	900	200
N4, N5	450	n/a	n/a	200
N6	300	n/a	n/a	150
C1	450	900	900	200
C2	450	n/a	900	200
C3	450	n/a	800	200
C4	300	n/a	850	150

Contact your local BGC Fibre Cement office for further advice if required.

## DURABATTEN INSTALLATION

### STEEL DURABATTEN

Can only be fixed off stud. Refer to Span Table for stud/batten fastener spacings. Note: Off stud max span (noggin spacing) 800mm centres.

#### FIGURE 8 / OFF STUD

Ensure noggin is fixed to framing as noted

Steel Durabatten

Steel Frame

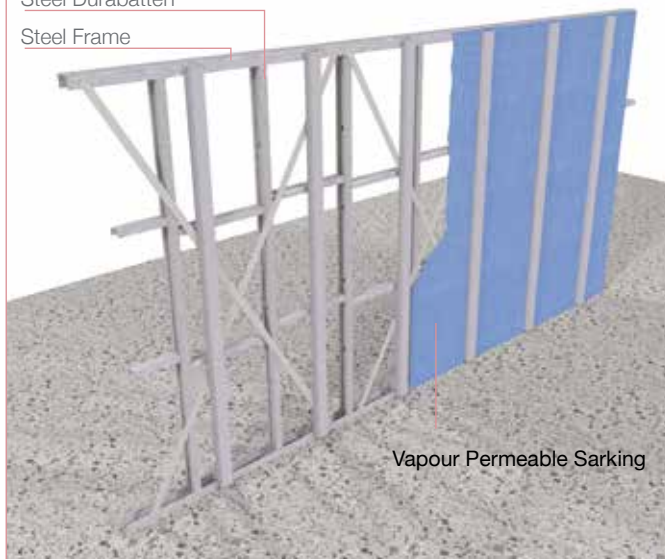

Vapour Permeable Sarking

## BATTEN JOINING

#### FIGURE 9 / BATTEN JOINING

45° Weather cut sloping down & away from Vapour Permeable Sarking

Sealant

Vapour Permeable Sarking

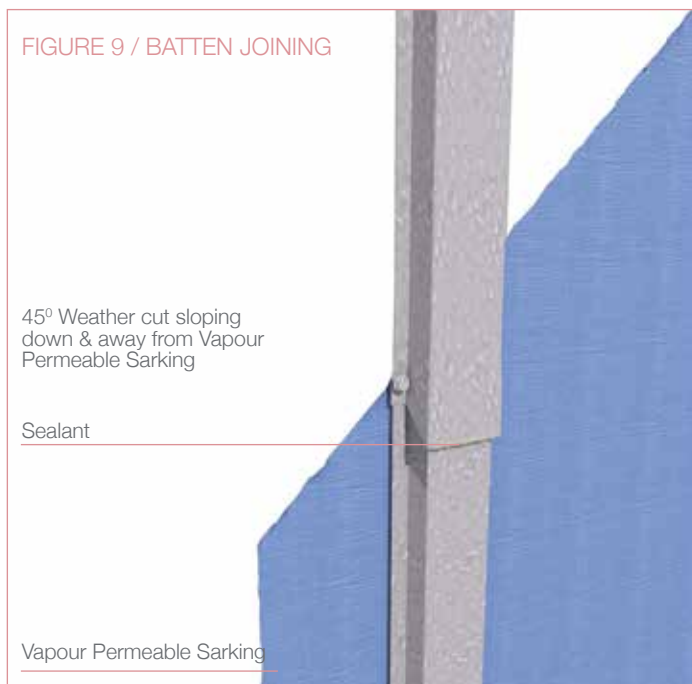

## INSTALLATION DETAILS

The architectural intent and details of buildings vary from one designer to the next, and the variety of details would be impossible to catalogue.

The detail diagrams following are intended to assist the designer in achieving a high quality weather resistant facade.

The designer should not digress from the specification set out in this manual.

#### FIGURE 10 / PANEL POSITION - FRONT VIEW

Polyurethane film 0.8mm - 1.00mm thickness over exposed batten face\*.

10mm Exposed Joint

Steel Durabatten

Backing Strip

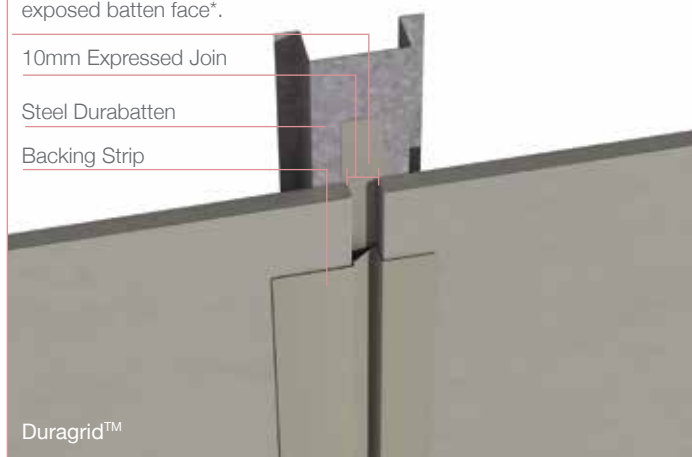

Duragrid™

Use the backing strip as a temporary gauge to space the vertical joint of successive boards ensuring a uniform 10mm space between successive panels. Use the backing strip to space vertical panel joints.

\* Components not supplied by BGC

## INSTALLATION DETAILS

FIGURE 11 / PANEL INSTALLATION

Durabatten Steel

Using a spirit level ensure panels are plumb and aligned with your datum line

Apply a continuous 6mm diameter bead of joint sealant to the Durabatten at each panel edge and on all contact surfaces

Datum line

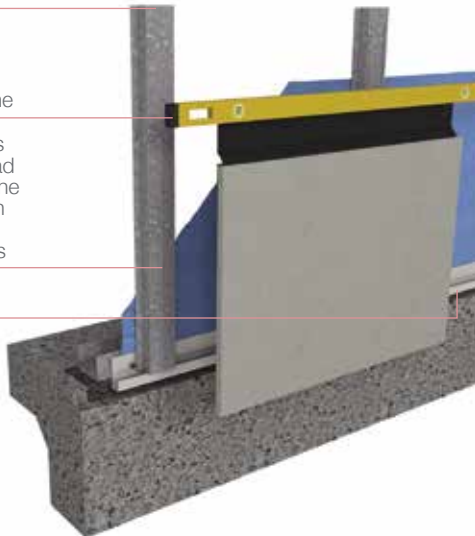

FIGURE 12 / TYPICAL SEALANT APPLICATION

Sikaflex IIFC or similar

Polyurethane film 0.8mm - 1.00mm thickness over exposed batten face.

Durabatten Steel

Vapour Permeable Sarking\*

Backing strip

Continuous 6mm bead of Sikaflex IIFC or similar

Sikaflex IIFC or similar

Duragrid™

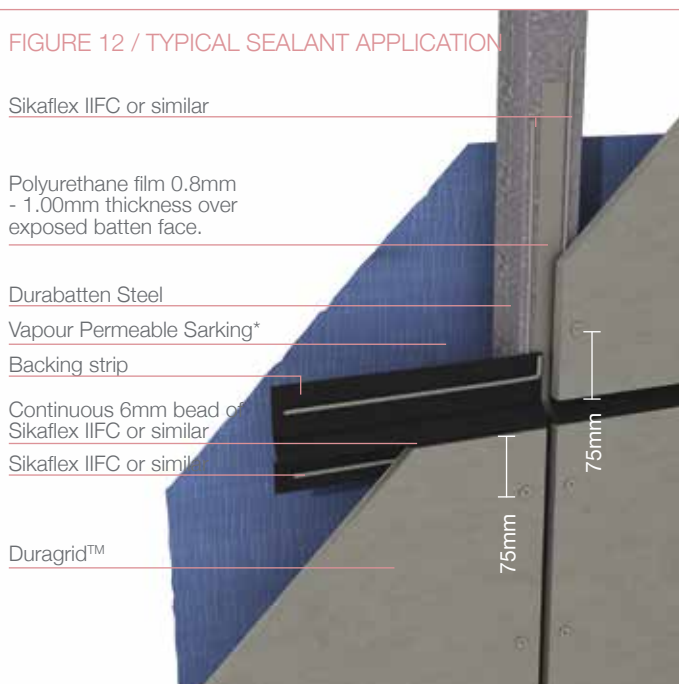

FIGURE 13 / FASTENER SPACING

Vapour Permeable Sarking\*

Duragrid™

Horizontal express joint with backing strip behind

Fastener spacing 200mm centres

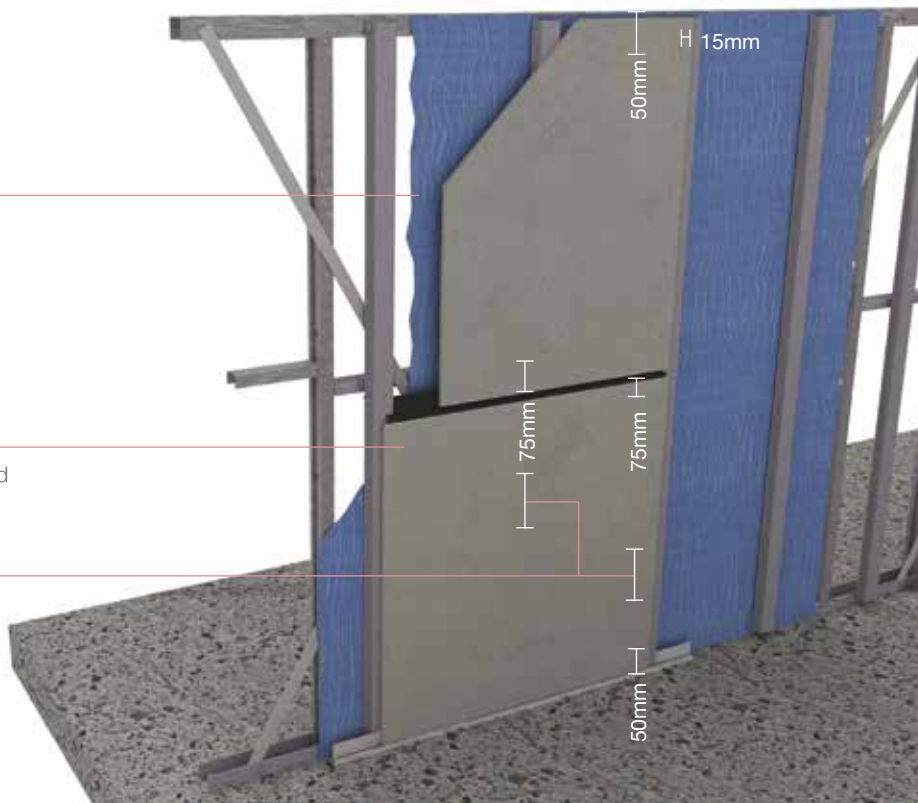

Duragrid™ panels are to be fixed with a continuous 6mm bead of Sikaflex1 IFC or similar polyurethane sealant/adhesive to all contact surfaces with required fasteners at specific centres. Cover the exposed face of battens with a layer of polyurethane sealant to ensure durability of the Durabatten.

Duragrid™ panels should be sealed and fixed one panel at a time. Only apply sealant to the contact surface of the next panel to be fixed.

\* Components not supplied by BGC



## INSTALLATION DETAILS

FIGURE 14 / SOFFIT DETAIL

BGC Durasheet™

Steel Frame\*

Steel Durabatten

Duragrid™

Vapour Permeable Sarking\*

BGC Interior Liningboard



FIGURE 15 / FOUNDATION DETAIL

BGC Interior Liningboard

Steel Durabatten

Duragrid™

Ensure the Durabatten does not sit inside the cavity closer

uPVC Cavity Closer

Damp Course\*



\* Components not supplied by BGC

## INSTALLATION DETAILS

FIGURE 16 / INTERNAL CORNER DETAIL

Steel Frame\*

Flashing\*

Sealant\*

Steel Durabatten

BGC Interior Lining

Vapour Permeable Sarking\*

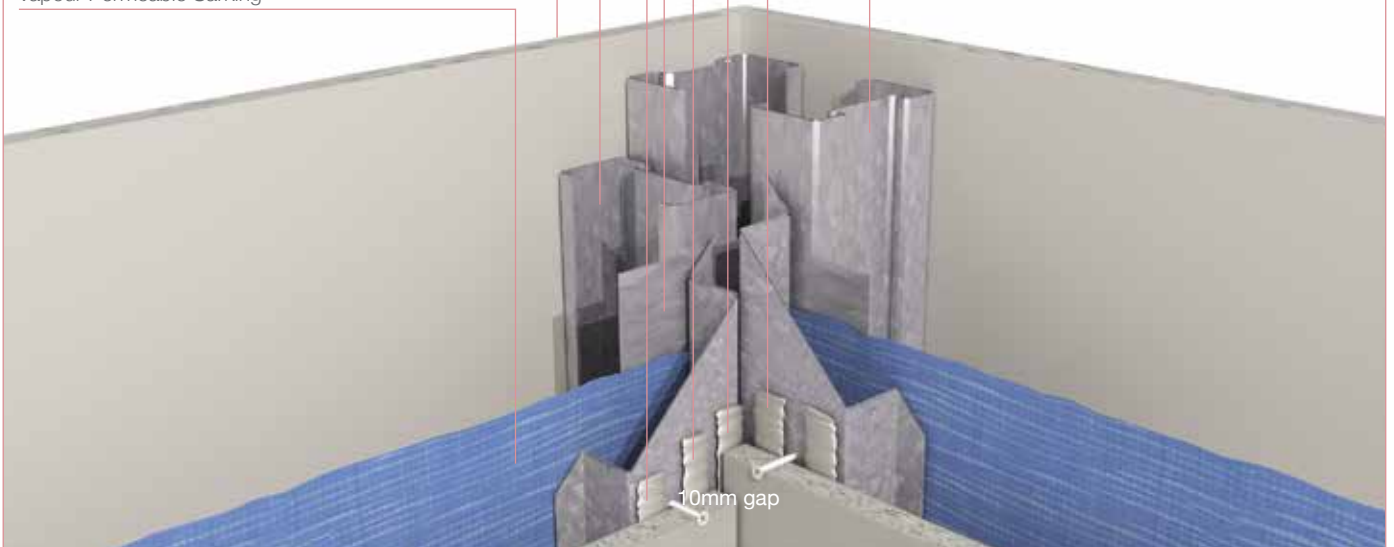

FIGURE 17 / EXTERNAL CORNER DETAIL

BGC Interior Liningboard

Steel Frame

Vapour Permeable Sarking\*

Steel Durabatten

Sealant\*

Duragrid™

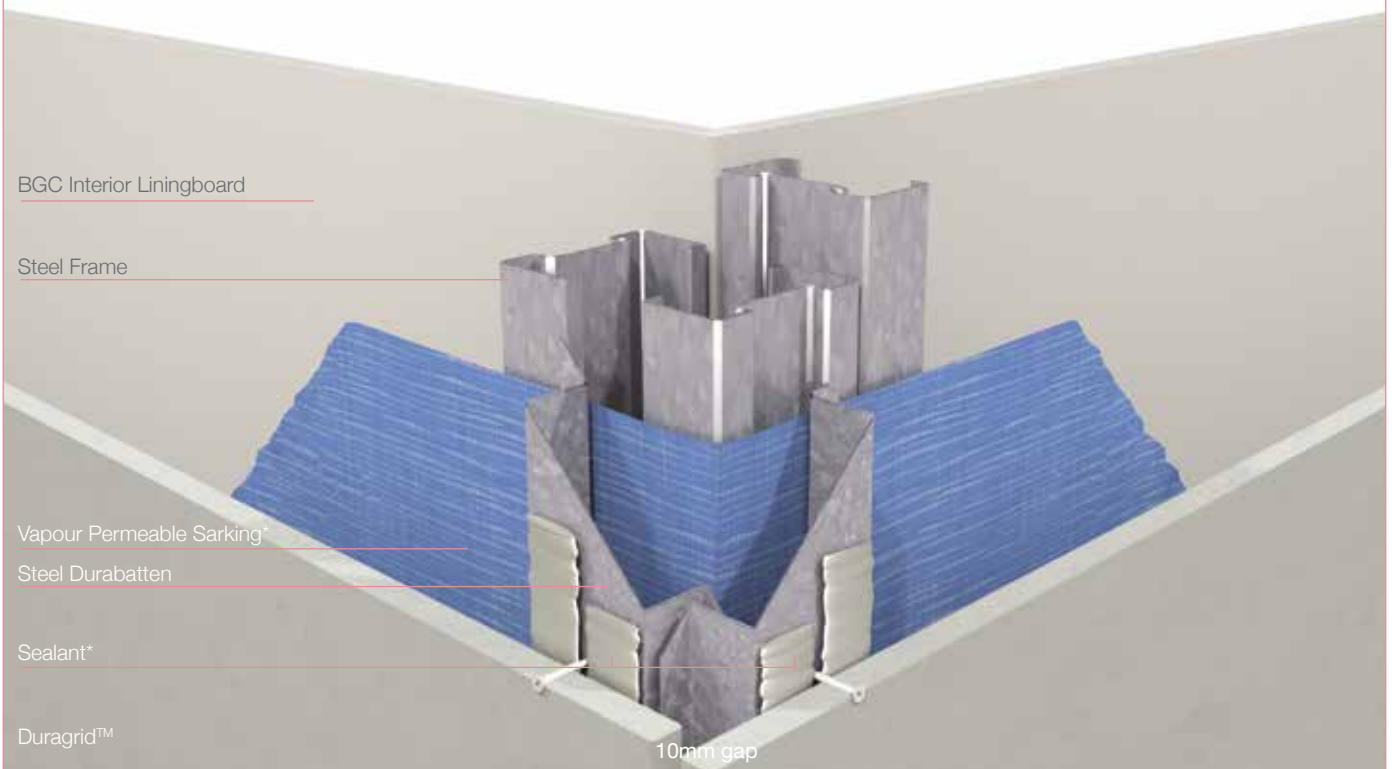

\* Components not supplied by BGC





## PENETRATIONS, WINDOW & DOOR OPENINGS

There are numerous varieties of penetrations, openings, and window and door treatments available. Each weather proofing detail will be dependent on the material, style and manufacturer's specifications.

Adequate weather proofing must be considered by the building designer, in conjunction with the penetration, window or door manufacturer.

The following diagrams below are a guide only and the designer should consult with the appropriate manufacturers for the detail design to ensure adequate weather proofing.

FIGURE 19 / WINDOW JAMB

BGC Interior Liningboard

Packer (as required)\*

Vapour Permeable Sarking\*

Steel Durabatten

Sealant

Duragrid™

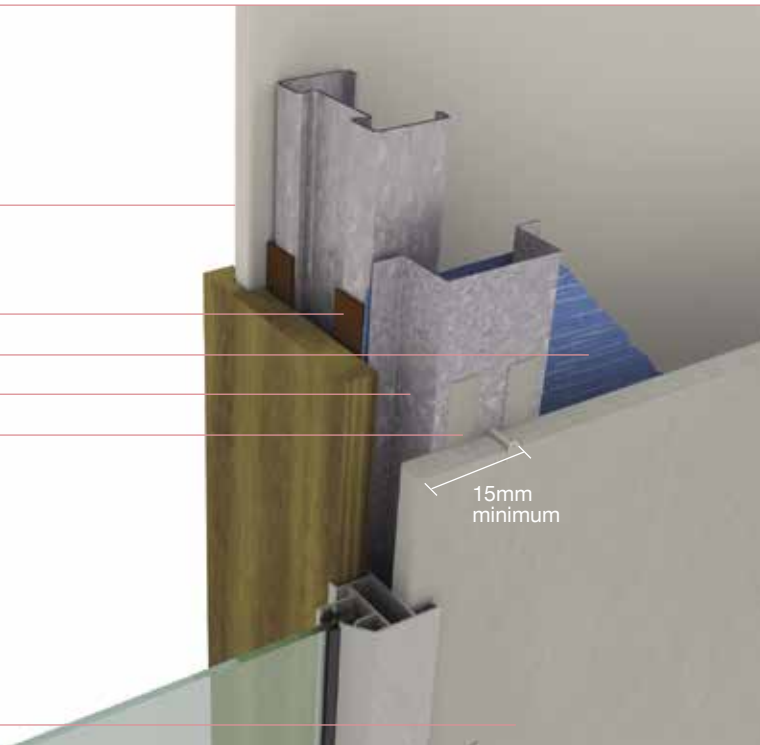

FIGURE 20 / EXPRESS JOINT DETAIL & FASTENER POSITION

Continuous 6mm bead of Sikaflex IIFC or similar

Polyurethane film 0.8mm - 1.00mm thickness over exposed batten face\*.

Steel Durabatten

Fastener\*

Duragrid™

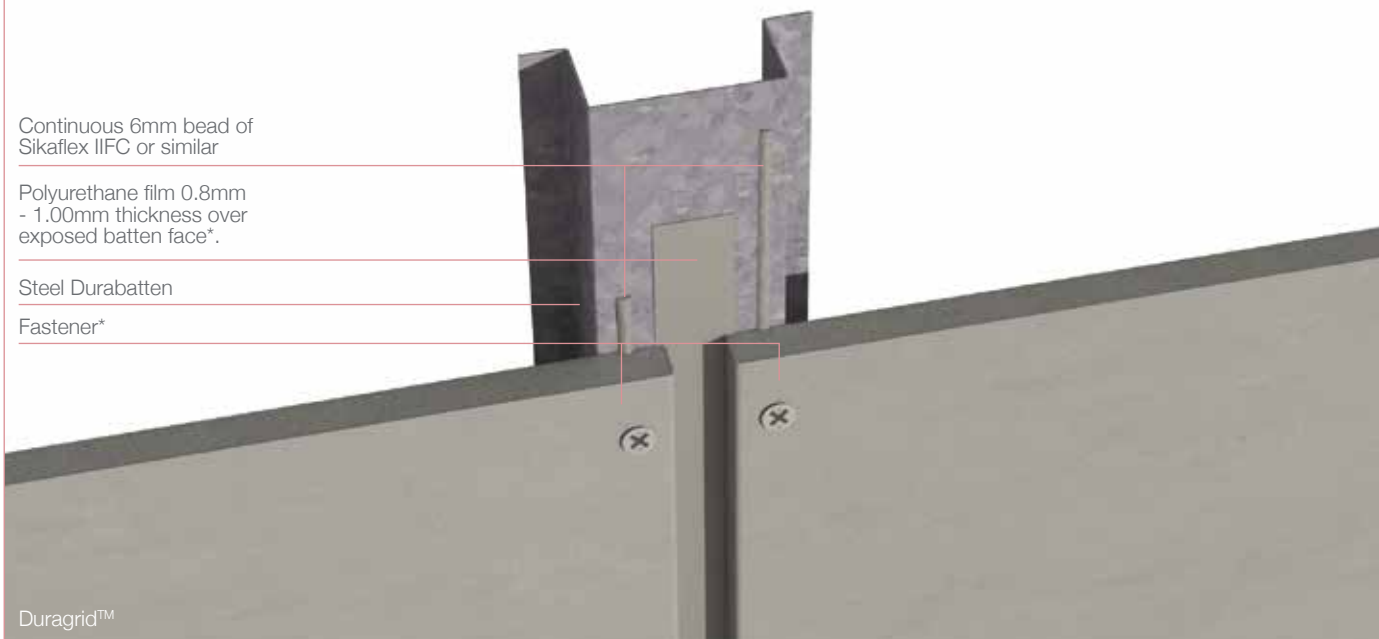

\* Components not supplied by BGC

FIGURE 21 / WINDOW HEAD

- Duragrid™
- BGC Interior Liningboard
- Steel Durabatten
- Steel Frame
- Vapour Permeable Sarking\*
- Flashing\*
- Packer (as required)\*
- Aluminium window joinery\*

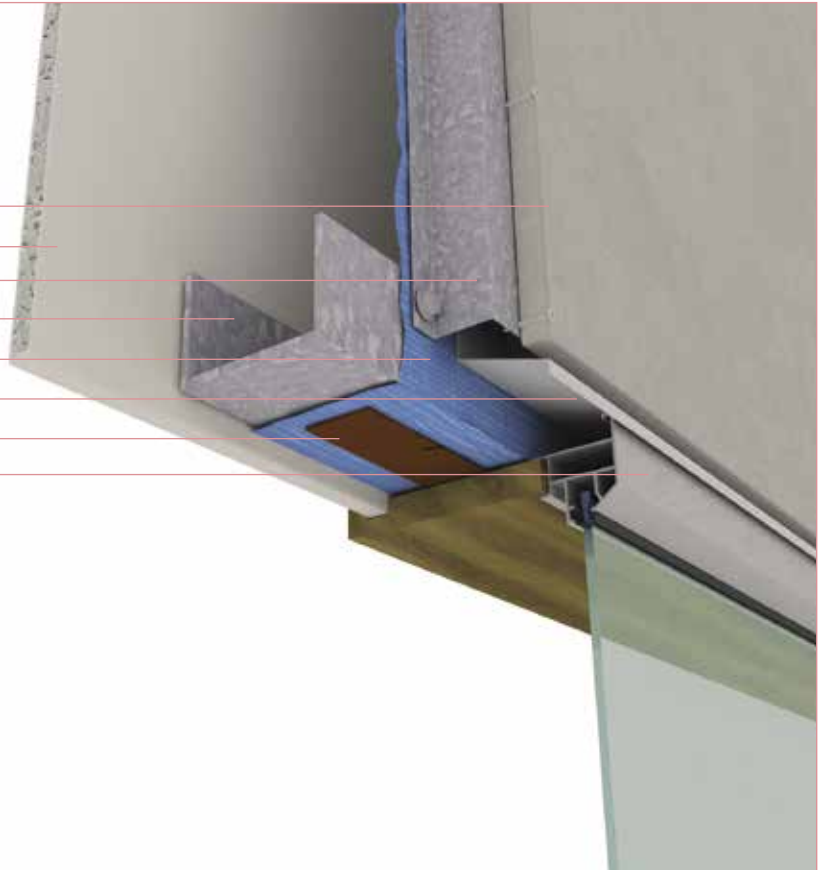
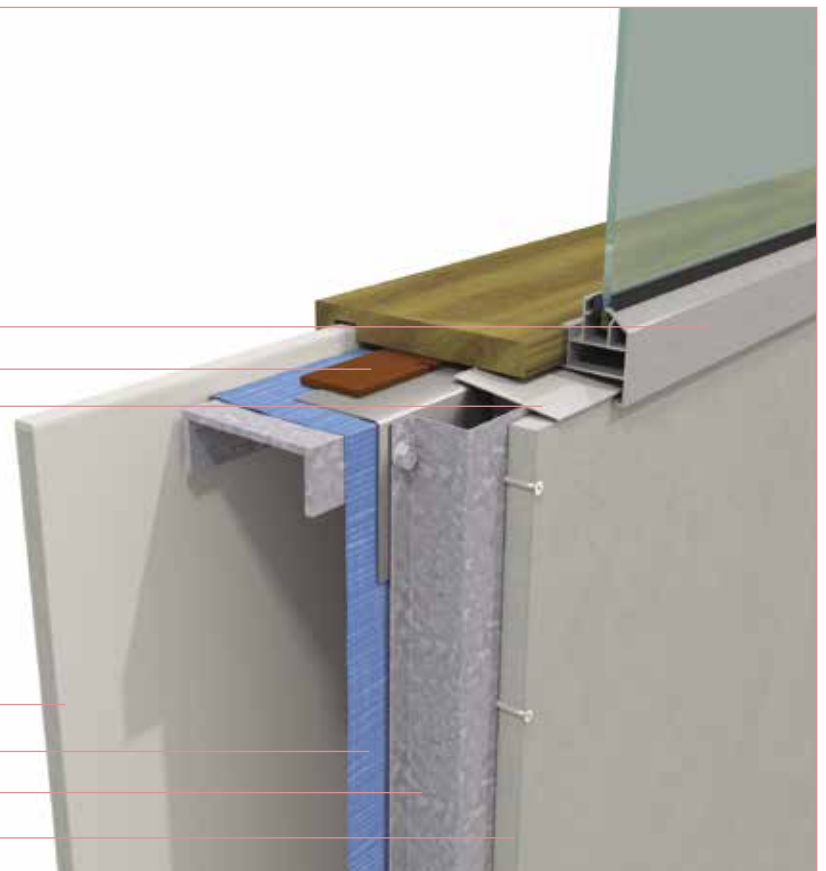

FIGURE 22 / WINDOW SILL

- Aluminium window joinery\*
- Packer (as required)\*
- Sill tray 5° min slope\*

- BGC Interior Liningboard
- Vapour Permeable Sarking\*
- Steel Durabatten
- Duragrid™



\* Components not supplied by BGC

## DEEMED TO COMPLY

For an up to date and complete list of BGC Products that are 'Deemed to Comply' please refer to [www.ntlis.nt.gov.au/deemedtocomply](http://www.ntlis.nt.gov.au/deemedtocomply)

## WARRANTY

We warrant that our products are free from defects caused by faulty manufacture or materials for the following period from the date of purchase:

- 25 years for the Nuline™ Plus, Stratum™ and Duraplank™ ranges
- 10 years for the Montage™ range and
- 15 years for all other BGC Fibre Cement and Innova™ ranges

If you acquire any defective products, we will repair or replace them, supply equivalent replacement products or refund the purchase price within 30 days of receiving a valid claim, subject to product inspection and confirmation of the existence of a defect by BGC. We will bear the cost of any such repair, replacement or refund.

This warranty is given by:

### **BGC Fibre Cement Pty Ltd**

Ground Floor, 290 Bushmead Road, Hazelmere WA 6055  
Phone 08 9374 2900 Fax 08 9374 2901

To claim under this warranty, you must provide proof of purchase as a consumer and make a written claim (including any costs of claiming) to us at the address specified above within 30 days after the defect was reasonably apparent, or if the defect was reasonably apparent prior to installation, the claim must be made prior to installation. You may not claim under this warranty for loss or damage caused by:

- faulty or incorrect installation by non-BGC installers (BGC's installation procedures are at [www.bgcinnovadesign.com.au](http://www.bgcinnovadesign.com.au));
- failure to comply with the Building Code of Australia or any applicable legislation, regulations approvals and standards;
- products not made or supplied by BGC;
- abnormal use of the product; or
- normal wear and tear.

The benefits available under this warranty are in addition to other rights and remedies of the consumer under the law. Our goods come with guarantees that cannot be excluded under the Australian Consumer Law. You are entitled to a replacement or refund for a major failure and for compensation for any other reasonably foreseeable loss or damage.

You are also entitled to have the goods repaired or replaced if the goods fail to be of acceptable quality and the failure does not amount to a major failure.

\* Components not supplied by BGC







## CONTACT

---

TO CONTACT  
YOUR NEAREST  
BGC STOCKIST,  
PLEASE CALL:

---

**ADELAIDE**  
TELEPHONE  
08 8480 1700

**BRISBANE**  
TELEPHONE  
07 3548 8400

**MELBOURNE**  
TELEPHONE  
03 9492 1700

**PERTH**  
TELEPHONE  
08 9492 2900

**SYDNEY**  
TELEPHONE  
02 8107 9500

**NEW ZEALAND**  
TELEPHONE  
0011 64 9273 1457

**TECHNICAL HELP LINE**  
1300 652 242

---



# BGC FIBRE CEMENT PROVIDES BUILDERS, DEVELOPERS AND ARCHITECTS WITH A RANGE OF DESIGN ALTERNATIVES AND INNOVATIVE PRODUCTS, SUCH AS:

---

## EXTERIOR PRODUCTS AND APPLICATIONS INNOVA RANGE OF PRODUCTS

---

**DURACOM™** / A compressed fibre cement facade system.

**DURAFLOOR™** / Is the ultimate flooring product that can be used in both interior and exterior applications.

**DURAGRID™ RESIDENTIAL & DURAGRID™ LIGHT COMMERCIAL** / A light weight facade giving a modern and durable finish.

**DURAGROOVE™** / A vertically grooved exterior facade panel.

**DURASCAPE™** / A lightweight exterior facade base sheet with a subtle vertical shadow line.

**DURACOM GREYSTONE™** / A pre-finished facade system.

**MONTAGE™** / A pre-finished versatile facade system that can be used internally and externally.

**NULINE™ PLUS** / A weatherboard style cladding system.

**STONESHEET™** / Purpose designed substrate for stone tile facade.

**STRATUM™** / Is a trio of plank products, each of which can be used as stand alone products or used together to create a striking exterior cladding solution.

---

## EXTERIOR PRODUCTS AND APPLICATIONS BGC FIBRE CEMENT RANGE OF PRODUCTS

---

**DURASHEET™** / Ideal for the cladding of gables and lining of eaves. Can also be used on commercial soffits and cladding on non impact areas.

**DURAPLANK™** / Available in Smooth, Woodgrain and Rusticated finishes, Duraplank™ is ideal for exterior cladding of upper storey conversions or ground level extensions.

**DURATEX™** / A base sheet used for textured coatings on exterior wall applications.

**DURALINER™ PLUS** / An exterior lining board, this is the perfect substrate for tiles and is ideal for wet areas.

**COMPRESSED** / Used for domestic, commercial sheet for wet areas, flooring, partitions, exterior decking, fascia and facade cladding.

**DURALUX™ PLUS** / Suitable for exterior applications where it will be sheltered from direct weather.

---

## INTERIOR PRODUCTS AND APPLICATIONS BGC FIBRE CEMENT RANGE OF PRODUCTS

---

**DURALUX™ PLUS** / An interior lining board suitable for ceilings and soffits.

**DURALINER™ PLUS** / An interior lining board, this is the perfect substrate for tiles and is ideal for wet areas.

---