

Supreme Cavity Door Slider

Southside

4 Judds Court, Slacks Creek Qld 4127

Email SOUTH ORDERS to
sales@brisaluminium.com

Northside

12 Saltash St, Virginia Qld 4014

Email NORTH ORDERS to
salesnorth@brisaluminium.com



FIT MORE BOARDS

New & Improved System Adaptors

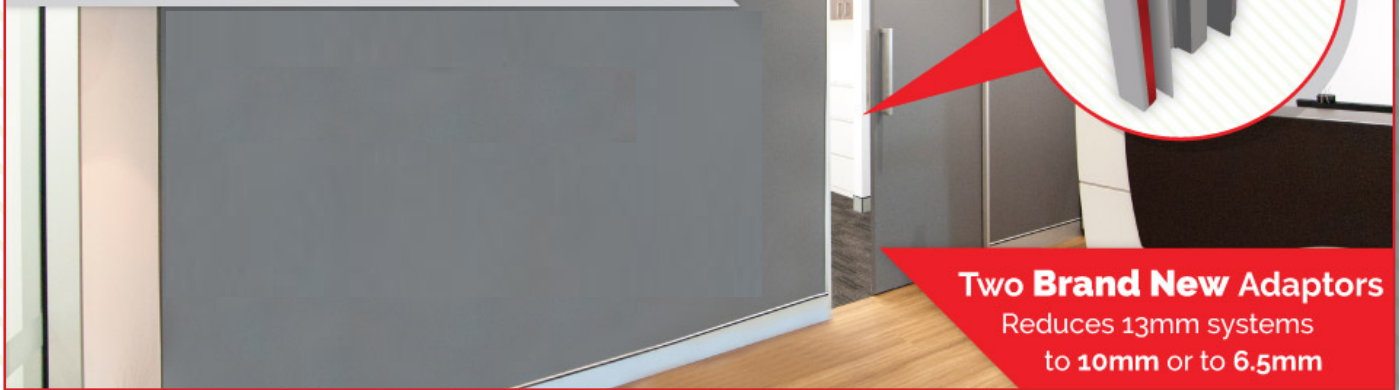

Two Brand New Adaptors

Reduces 13mm systems to 10mm or to 6.5mm

Medical Fitouts

It's a great product to use where you have minimal office space and you have no room to fit a swing door



IT ROOMS

Its a great product for turning a small space into an IT server room.



BOARDROOMS

The product has a high end finish and is great for executives whom want a unique entrance to the boardroom



APARTMENTS

For residential apartments the product represents an entry of grandeur.



We now have **2 NEW** simple to fit adaptors to increase the flexibility of our Supreme Partitioning Systems!

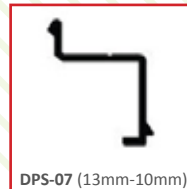

DPS-07 reduces the 13mm to 10mm to accommodate 10mm plasterboard or 9mm Villaboard

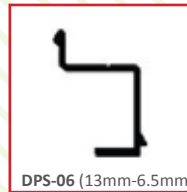

DPS-06 reduces the 13mm to 6.5mm to accommodate 6mm Villaboard

This enables you to set 13mm plasterboard on one side of a wall and a range of mediums on the other or allows our 13mm DPS framing systems to be used to match combinations of the range of coverings.

Important



Call: 1300BRIS01 (1300 274 701)

 /brisaluminium

 /company/bris-aluminium

STANDARD CAVITY SLIDING DOOR UNIT

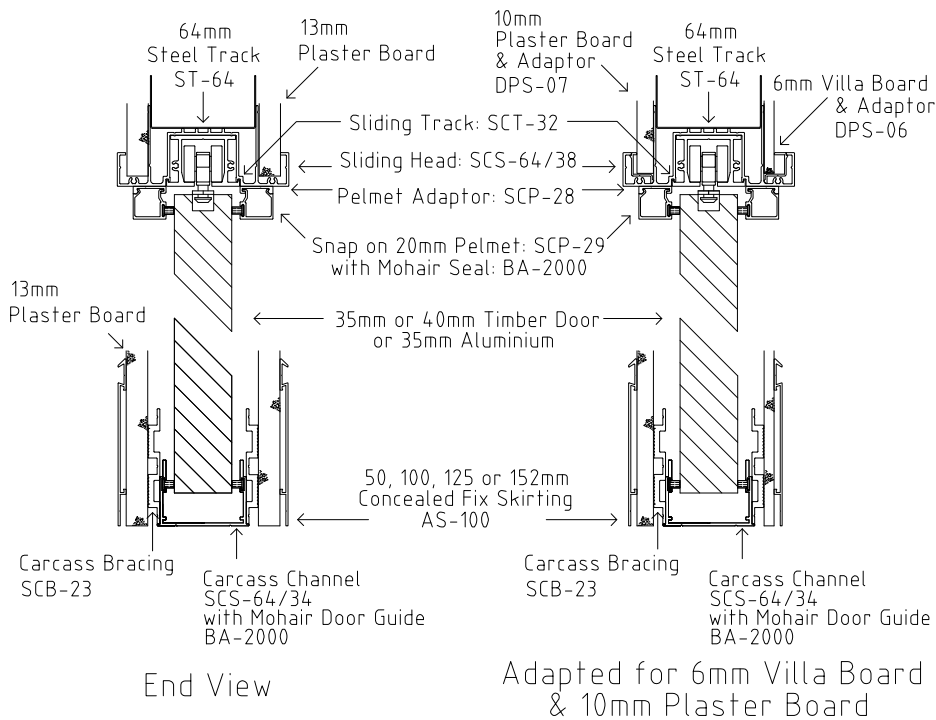

Benefits are

- To suit door widths 35mm or 40mm thick timber and 35mm thick aluminium
- Door sizes up to 2700 x 1200 and 2400 x 1500
- Maximum Door Weight = 100kg
- Disable code easily achieved using 1000mm standard pocket and 1050 door
- Double Door Cavities are available on request

Tech Data

- Swiss engineered and built rollers for a smooth glide
- Instruction video on website
- Pelmet included
- Adaptors to suit 10mm plasterboard and 6mm or 9mm Villa board
- Available in custom heights and widths

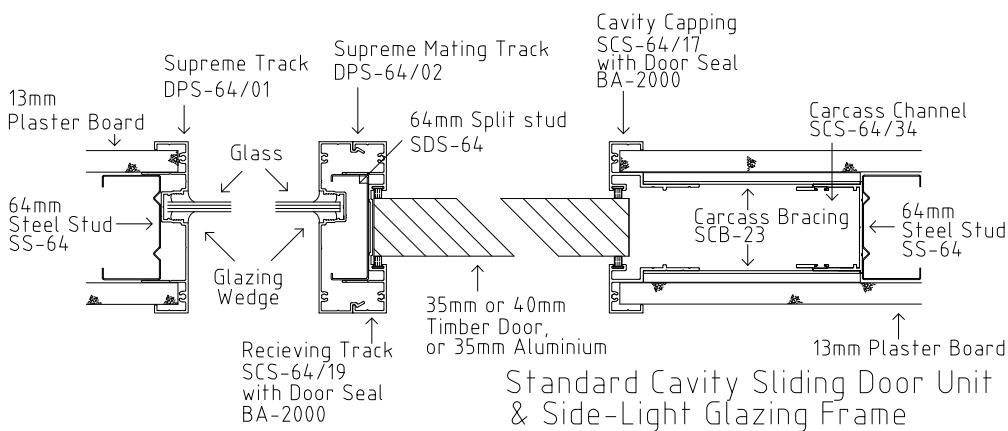
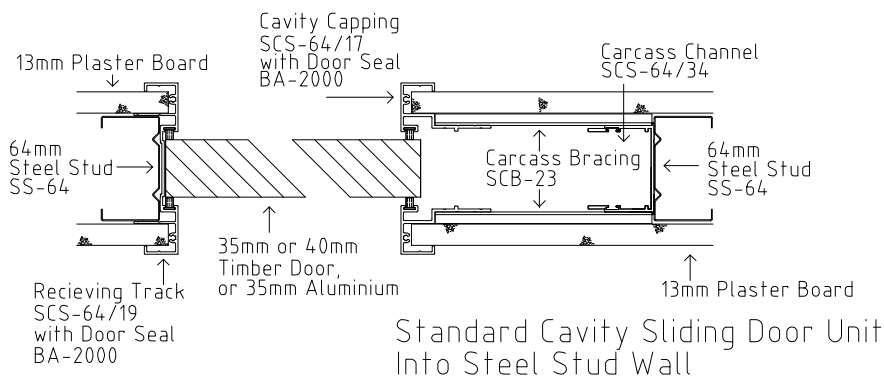

Lead Time

Clear Anodised Kits available with a minimal lead time.
Powder Coated Kits are subject to Powder Coat lead times.

76 Supreme Cavity System

Supreme 76

STANDARD CAVITY SLIDING DOOR UNIT

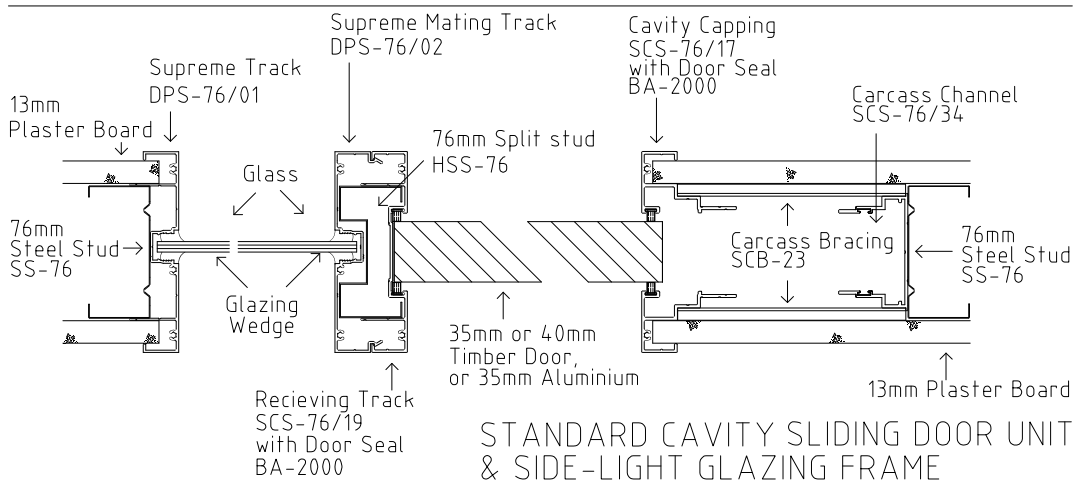
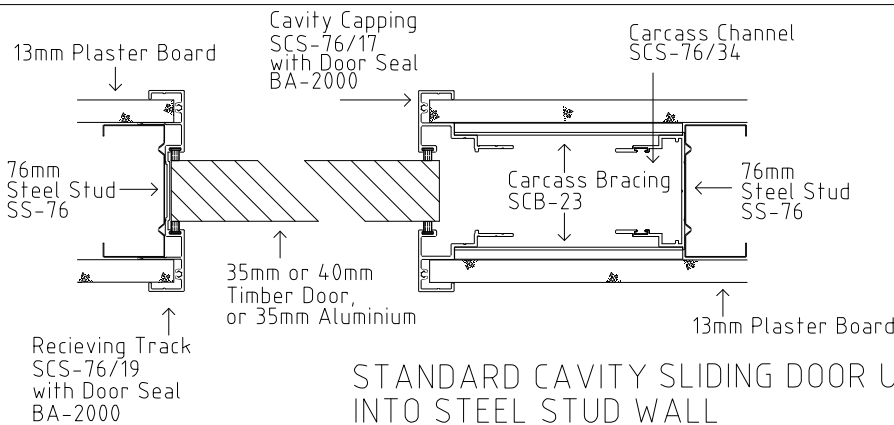
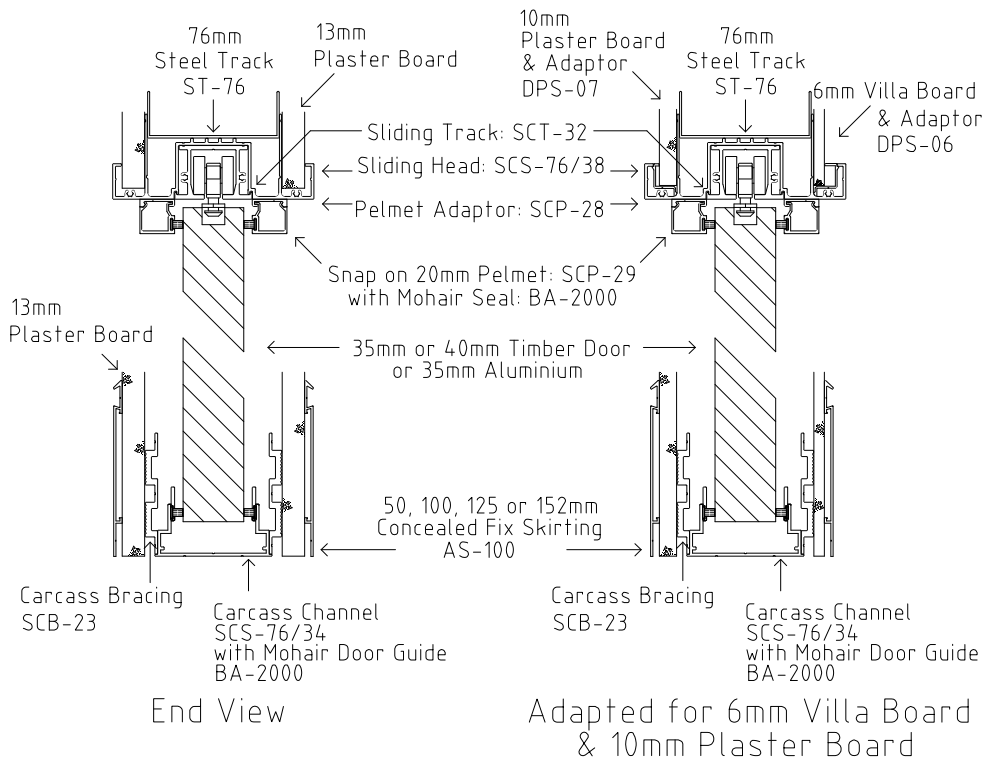

Benefits are

- To suit door widths 35mm or 40mm thick timber and 35mm thick aluminium
- Door sizes up to 2700 x 1200 and 2400 x 1500
- Maximum Door Weight = 100kg
- Disable code easily achieved using 1000mm standard pocket and 1050 door
- Double Door Cavities are available on request

Tech Data

- Swiss engineered and built rollers for a smooth glide
- Instruction video on website
- Pelmet included
- Adaptors to suit 10mm plasterboard and 6mm or 9mm Villa board
- Available in custom heights and widths



 /brisaluminium

 /company/bris-aluminium

Lead Time

Clear Anodised Kits available with a minimal lead time. Powder Coated Kits are subject to Powder Coat lead times.

Call: 1300BRIS01 (1300 274 701)

STANDARD CAVITY SLIDING DOOR UNIT

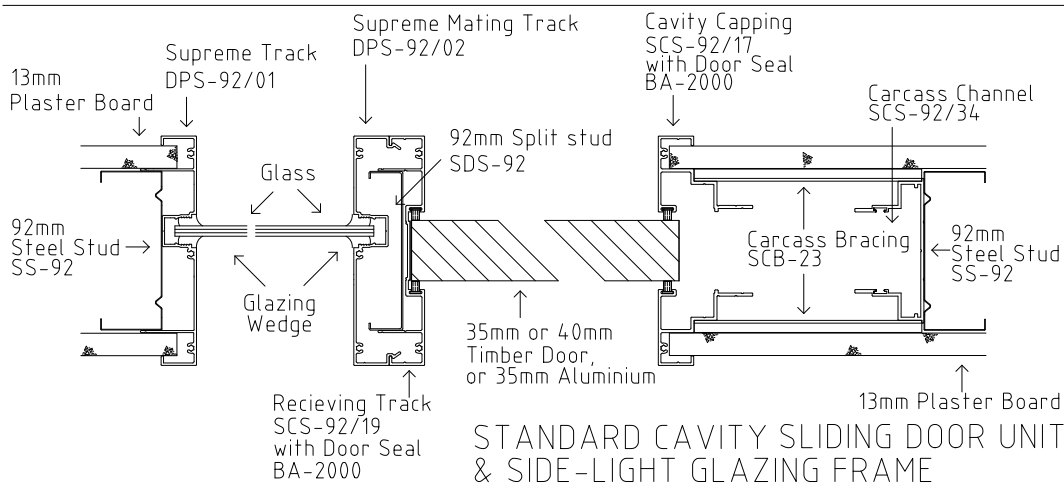
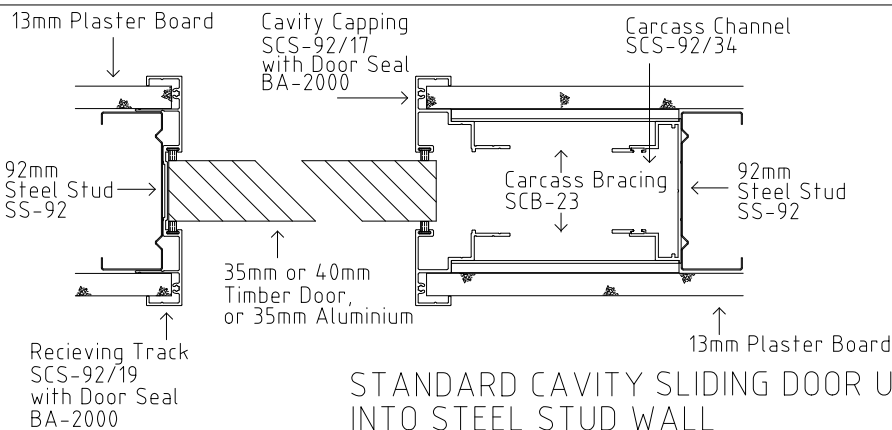
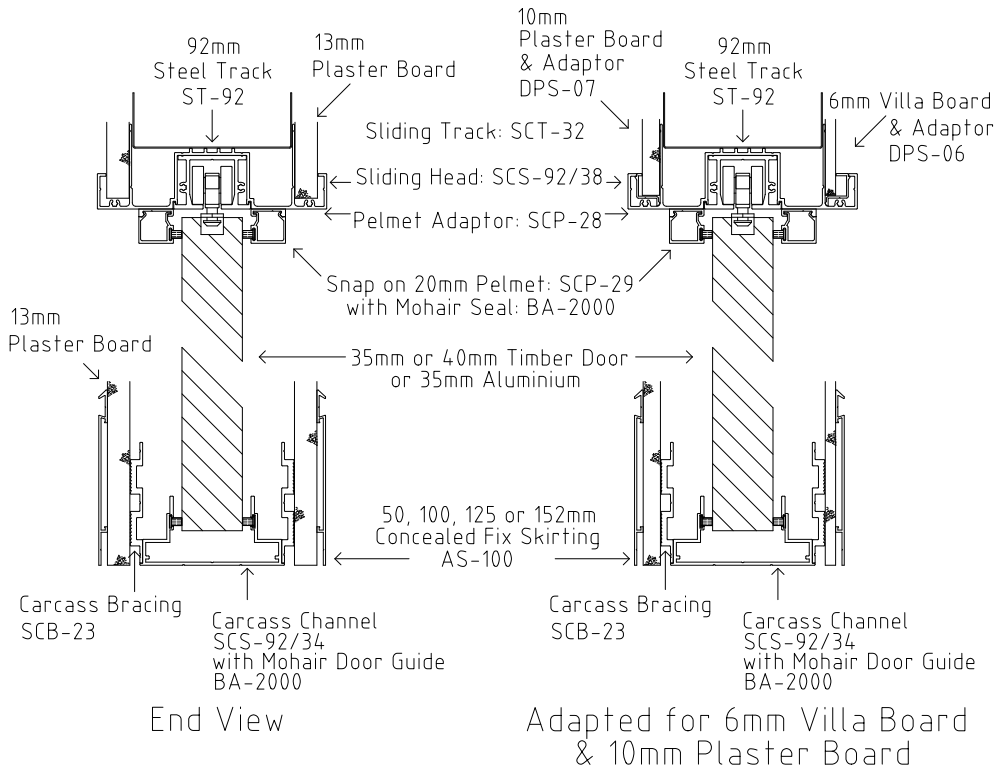

Benefits are

- To suit door widths 35mm or 40mm thick timber and 35mm thick aluminium
- Door sizes up to 2700 x 1200 and 2400 x 1500
- Maximum Door Weight = 100kg
- Disable code easily achieved using 1000mm standard pocket and 1050 door
- Double Door Cavities are available on request

Tech Data

- Swiss engineered and built rollers for a smooth glide
- Instruction video on website
- Pelmet included
- Adaptors to suit 10mm plasterboard and 6mm or 9mm Villa board
- Available in custom heights and widths



Lead Time

Clear Anodised Kits available with a minimal lead time. Powder Coated Kits are subject to Powder Coat lead times.

64 Setting Supreme Cavity System

Supreme 64

STANDARD CAVITY SLIDING DOOR UNIT

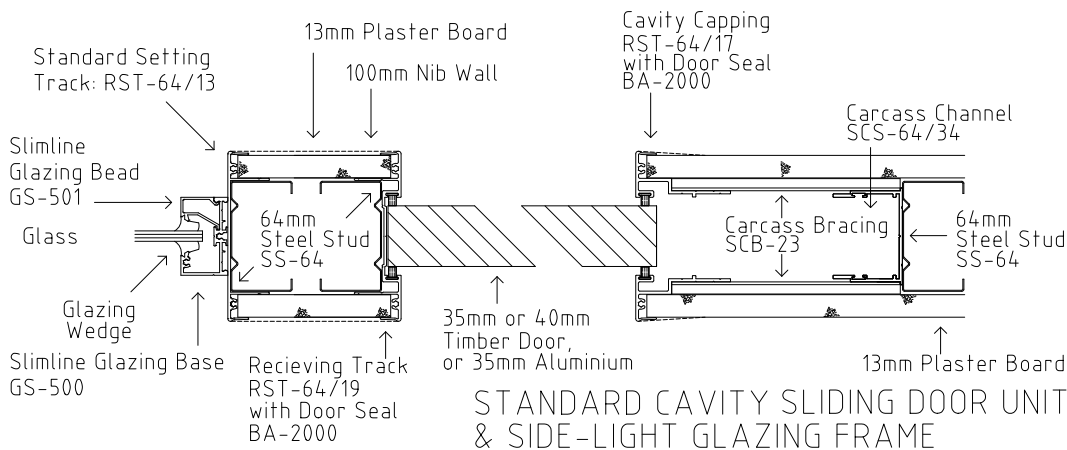
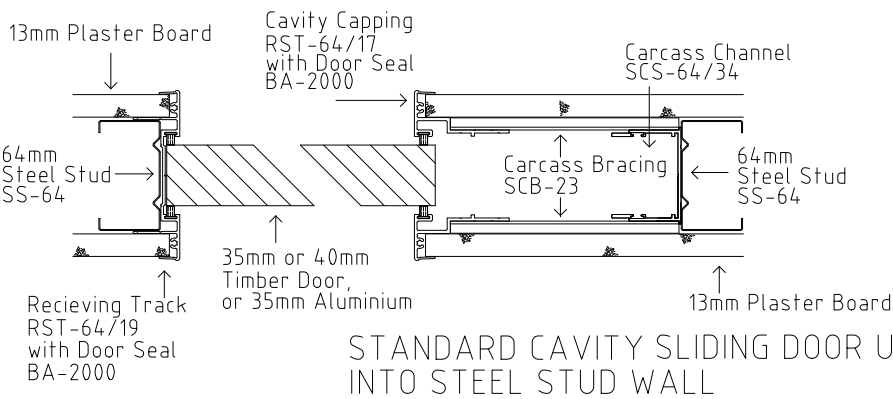
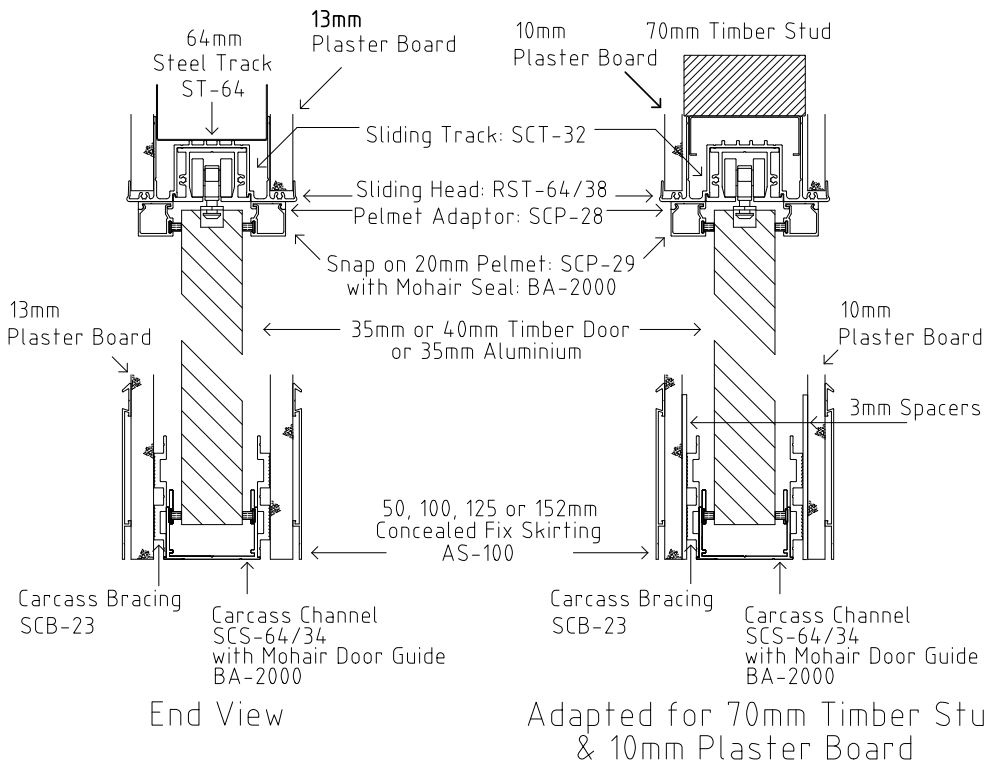

Benefits are

- To suit door widths 35mm or 40mm thick timber and 35mm thick aluminium
- Door sizes up to 2700 x 1200 and 2400 x 1500
- Maximum Door Weight = 100kg
- Disable code easily achieved using 1000mm standard pocket and 1050 door
- Double Door Cavities are available on request

Tech Data

- Swiss engineered and built rollers for a smooth glide
- Instruction video on website
- Pelmet included
- Adaptors to suit 10mm plasterboard and 6mm or 9mm Villa board
- Available in custom heights and widths



 /brisaluminium

 /company/bris-aluminium

Lead Time

Clear Anodised Kits available with a minimal lead time.
Powder Coated Kits are subject to Powder Coat lead times.

Call: 1300BRIS01 (1300 274 701)

standard FEATURES

frame sizes
per your door specification
available in
custom heights & widths

CUSTOM SPEC to fit your needs

- ✓ Standard 1m wide carcass
- ✓ Fits 35mm aluminium door, 35mm & 40mm timber door
- ✓ Easy to install with instructions provided and video on website
- ✓ Purpose built for steel stud sizes 64mm, 76mm or 92mm stud with 13mm plasterboard
- ✓ Villaboard no problem with our new 13mm to 6.5mm adapter for 64, 76 & 92 Supreme Systems
- ✓ Swiss made rollers and carriages rated to 100kg
- ✓ Pelmet are included in all kits which are available with minimal lead time



The perfect addition to our 64mm, 76mm and 92mm Supreme Systems, the Cavity Door Slider has now matured into our flagship sliding solution. With a wide range of indoor applications, we've yet to receive anything but positive feedback.

The perfect solution for limited space where a hinged door is not practical such as doctor or dentist consultation and treatment rooms. Also for opening up spaces for board rooms and offices - multipurpose rooms.

Coming in a standard 1m wide carcass, the Cavity Door Slider is also available in custom sizing to accommodate up to 1500mm wide doors.

The Cavity Slider offers modern, minimalist design matched with quality Hafele easy-glide rollers and self locking stop and latching

mechanisms. Along with the European quality, the rollers are easily removable for simple servicing.

Bris Aluminium has created a door which is stylishly functional. With pelmet and a receiving track, which leaves no gaps along the side of the closed door, the clean lines of the door will suit any modern office perfectly.

You can now get an even more minimalist look to the install due to the new set bead frame. This removes the aluminium trim around the door opening providing you with a flush finish with the wall.

It also has the added advantage of being supplied in a simple to install kit form. It's purpose-made packaging makes it easy to transport and protects it from damage.



 /brisaluminium

 /company/bris-aluminium

To see more, visit www.brisaluminium.com.au/cavity-door-slider/

For more information on how the Cavity Door Slider can work for your projects, give us a call on (07) 3299 5227 or (07) 3260 6077.



brisaluminium.com.au

Call: 1300BRIS01 (1300 274 701)

Villaboard is a trademark of James Hardie Australia

BRIS ALUMINIUM

Northside

12 Saltash St, Virginia Qld 4014

Email NORTH ORDERS to
salesnorth@brisaluminium.com



Virginia

MAP REF.
120 - P6



Southside

4 Judds Court, Slacks Creek Qld 4127

Email SOUTH ORDERS to
sales@brisaluminium.com

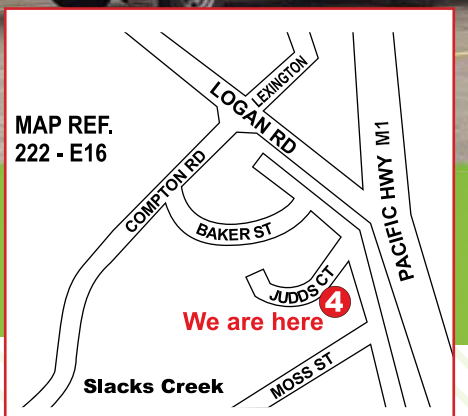

MAP REF.
222 - E16

Slacks Creek

over 20 YEARS
experience

Call: 1300BRIS01 (1300 274 701)