



**smuso** 

Smuso Soft Closing System  
for Sliding Doors  
soft and silent

## The logo of consistent soft closing systems for sliding doors weighing between 2 - 80kg

Häfele leads the way: For the first time, soft closing systems are available for all types of sliding doors - for furniture and also for buildings. For immediate installation or retrofitting.

Thanks to Smuso modular soft closing system, sliding doors in furniture and rooms are smoothly and silently brought to a stop where they are securely held. The soft closing systems may be retrofitted into already pre-installed sliding doors.

Smuso may also be recess mounted in the cabinet top for lightweight furniture sliding doors - An extremely aesthetic variant.

### Smuso - easy to install and can be retrofitted at any time



- Smuso soft close are specially designed and tested for different sliding doors.
- Many types of sliding doors can be retrofitted with Smuso soft closing systems. This is made possible by simple screw fixing.
- Improve the convenience and effectiveness of sliding doors using smuso soft close.
- The additional cost of installing the soft close feature always pays for itself.



### The different types of soft closing systems - suitable for any purpose:

#### Smuso SD

The luxury class for small and light weight furniture doors with leaf weights of 2-25 kg. For timber or glass doors.

#### Smuso AD

The premium class for sliding doors - particularly on door openings in buildings. For door leaf weights up to 80kg. A must for every contemporary sliding door.

Follower bracket for sliding door fittings:	 SD		 AD
	2 - 15kg 405.12.015	16 - 25 kg 405.12.025	up to 80 kg soft close with follower bracket
EKU-Clipo	405.12.301 F 405.12.300 R	405.13.301 F 405.13.300 R	-
EKU-Regal	405.12.302 R + F	405.12.302 R + F	-
HAWA Junior 80	-	-	940.80.043

F = front door R = rear door

## Soft Closing System for Sliding Doors

### The Advantages:



#### Less Noise

Soft closing sliding doors should be installed on furniture and in rooms where concentration and quiet are required, such as bedrooms, hotels and patient rooms, conference and meeting rooms, offices, doctors' surgeries, care and treatment rooms and wellness areas.



#### Avoid accidents

Anywhere that small children, the elderly or people in need of care are present, soft closing systems on sliding doors provide safety by effectively preventing fingers from being trapped in doors. The automatic gentle braking and closing of the door prevents slamming, and therefore goes a long way to stopping accidents from occurring.



#### Extremely convenient

Soft closing systems provide additional operating convenience on any sliding door. Less effort is required to close the doors, and they automatically glide gently into the end position. Conveniently and safely in any situation.



#### Material friendly

Hard collisions between the sliding doors, frames and end profiles cause additional wear to running gears, stoppers, tracks, door leaves and door profiles. The self closing mechanism and the soft closing system ensure that the sliding doors are protected and will last for many years.

# Soft Closing System for Sliding Doors

## Smuso SD 15/SD 25 Soft Closing Mechanism

For Sliding Door Fittings, with Self Closing Mechanism

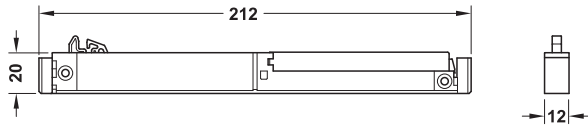

- Area of application: For light-weight and medium-weight sliding doors, 0 - 15 kg or 16 - 25 kg
- Material: Plastic
- Colour: Light grey
- Installation: For recess mounting or screw fixing to cabinet base

### Note:

Soft closing mechanism suitable for sliding door fittings

- EKU Regal B
- Clipo 15, front door
- Clipo 15, rear door

	Door weight kg	Cat. No.
Smuso SD 15 soft closing mechanism	2 - 15	405.12.015
Smuso SD 25 soft closing mechanism	16 - 25	405.12.025

Packing: 1 and 20 pieces

## Cover

For Smuso SD 15/SD 25 Soft Closing Mechanism

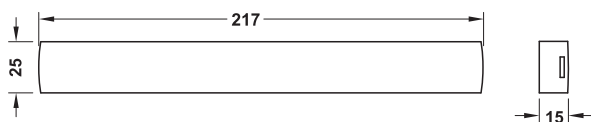
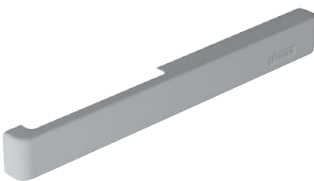

- Material: Plastic
- Installation: For clipping onto soft closing mechanism
- Suitable for: Left and right

	Colour	Cat. No.
Cover for Smuso SD 15/SD 25 soft closing mechanism	Grey	405.12.250
	Silver coloured	405.12.290

Packing: 1 and 20 pieces

## Follower Bracket for EKU Regal B

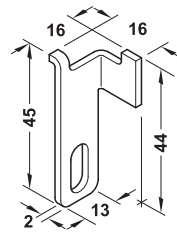

### Installation

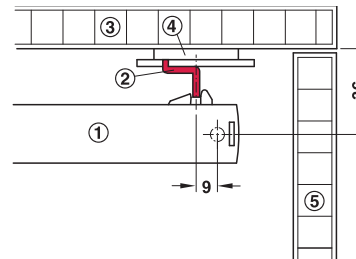

Follower bracket, pre-mounted

- 1 = Soft closing mechanism
- 2 = Follower bracket
- 3 = Sliding door
- 4 = Sliding door fitting
- 5 = Cabinet side

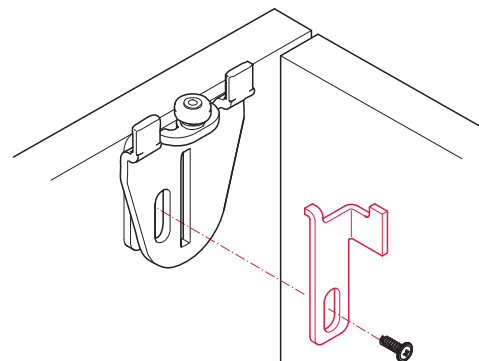

### Follower bracket installation

- Area of application: For cabinets with 1-leaf sliding doors with EKU Regal B sliding door fitting
- Material: Steel
- Finish: Galvanised

	Cat. No.
Follower bracket for EKU Regal B	405.12.302

Packing: 1 and 20 pieces

## Soft Closing System for Sliding Doors

### Follower Bracket for EKU Clipo 15, Front Door

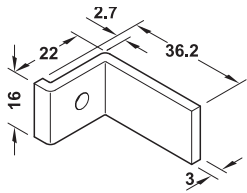

#### Installation

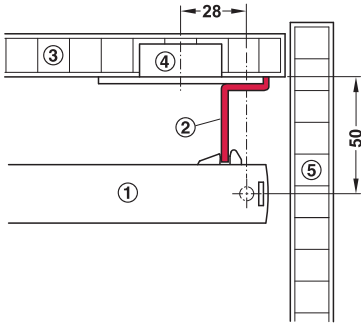

Follower bracket, pre-mounted  
 1 = Soft closing mechanism  
 2 = Follower bracket  
 3 = Sliding door  
 4 = Sliding door fitting  
 5 = Cabinet side

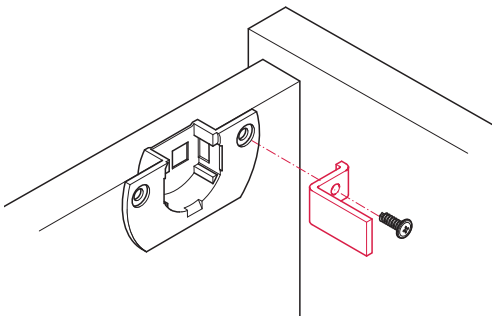

#### Follower bracket installation

- Area of application: For cabinets with 1-leaf sliding doors with Clipo 15 sliding door fitting
- Material: Steel
- Finish: Galvanised

	Cat. No.
Follower bracket for Clipo 15, front door	405.12.301

Packing: 1 piece

### Follower Bracket for EKU Clipo 15, Rear Door

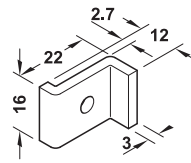

#### Installation

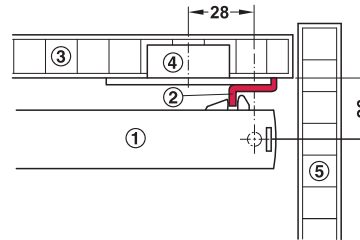

Follower bracket, pre-mounted  
 1 = Soft closing mechanism  
 2 = Follower bracket  
 3 = Sliding door  
 4 = Sliding door fitting  
 5 = Cabinet side

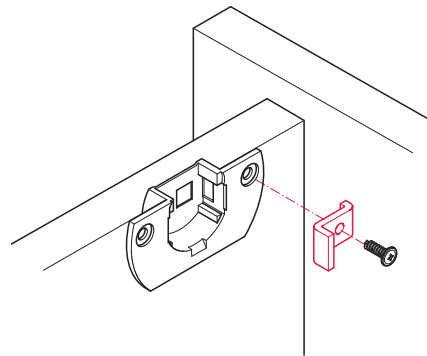

#### Follower bracket installation

- Area of application: For rear sliding door on cabinets with Clipo 15 sliding door fitting
- Material: Steel
- Finish: Galvanised

	Cat. No.
Follower bracket for Clipo 15, rear door	405.12.300

Packing: 1 piece

## Soft Closing System for Sliding Doors

### Smuso AD Soft Close For HAWA Junior 80

For Door Weights up to 80 kg



- Area of application: For 1-leaf and 2-leaf sliding doors  
Suitable for timber doors: HAWA Junior 80/Z, 80/B  
Suitable for glass doors: HAWA Junior 80/GL, 80/GP, 80/GV
- Max. door weight: 80 kg per door leaf
- Installation: For connection to running gear

#### Smuso AD Soft close, single leaf

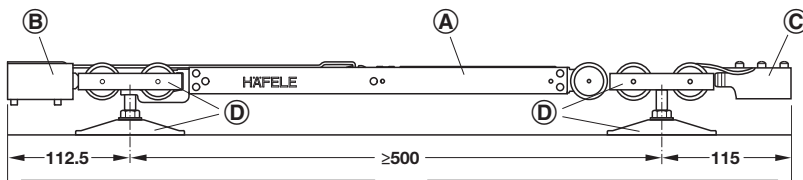

#### Smuso AD Soft close, double leaf bi-parting

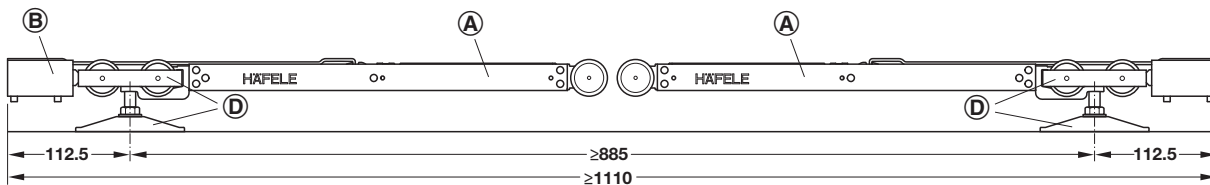

- (A) Häfele Smuso AD soft close
- (B) Häfele stopper with catch
- (C) HAWA track buffer
- (D) Junior 80 (example: Junior 80/Z)

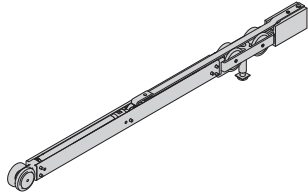
Smuso AD soft close for HAWA Junior 80 systems		Cat. No. 940.80.043
--	--	------------------------

#### Note

When using the double-leaf soft close together with the Junior 80 sets please note the following: The stopper supplied with the Junior 80 set is not required in this case. We recommend ordering individual components instead of the complete set for cost reasons.

## Soft Closing System for Sliding Doors



Dimensions in mm Dimensional data not binding. We reserve the right to alter specifications without notice.



## **HÄFELE AUSTRALIA PTY LTD.**

### **Design Centres**

#### **Melbourne Design Centre**

T: (03) 9212 2000  
F: (03) 9652 3701  
E: info@hafele.com.au

#### **Sydney Design Centre**

T: (02) 8788 2200  
F: (02) 8302 2101  
E: nsw@hafele.com.au

#### **Brisbane Design Centre**

T: (07) 3344 1533  
F: (07) 3253 3701  
E: qld@hafele.com.au

#### **Perth Design Centre**

T: (08) 9249 3833  
F: (08) 9215 6101  
E: wa@hafele.com.au

#### **Hobart Design Centre**

T: (03) 6331 7106  
F: (03) 6334 6414  
E: tas@hafele.com.au

### **State Offices**

#### **Victoria (Head Office)**

T: (03) 9212 2000  
F: (03) 9212 2001  
E: info@hafele.com.au

#### **New South Wales**

T: (02) 8788 2200  
F: (02) 8788 2201  
E: nsw@hafele.com.au

#### **A.C.T. & Southern NSW**

T: (02) 6202 2800  
F: (02) 6228 1418  
E: act@hafele.com.au

#### **Northern New South Wales**

T: (02) 8788 2200  
F: (02) 4921 0901  
E: nsw@hafele.com.au

#### **Queensland**

T: (07) 3307 8900  
F: (07) 3307 8901  
E: qld@hafele.com.au

#### **South Australia**

T: (08) 8232 9933  
F: (08) 8232 9977  
E: sa@hafele.com.au

#### **Western Australia / N.T.**

T: (08) 9249 3833  
F: (08) 9249 3328  
E: wa@hafele.com.au

#### **Tasmania**

T: (03) 6331 7106  
F: (03) 6334 6414  
E: tas@hafele.com.au

---

## **HÄFELE NEW ZEALAND LTD.**

### **Offices and Design Centres**

#### **Auckland Design Centre**

T: (09) 274 2530  
F: (09) 274 2531  
E: architectural@hafele.co.nz

#### **Eastern Design Centre**

T: (09) 274 2040  
F: (09) 274 2041  
E: info@hafele.co.nz

#### **Wellington Design Centre**

T: (04) 472 0294  
F: (04) 472 0295  
E: wellington@hafele.co.nz

#### **Christchurch Design Centre**

T: (03) 343 8200  
F: (03) 343 8201  
E: christchurch@hafele.co.nz

[www.hafele.com](http://www.hafele.com)