

HEATSTRIP[®]

INDOOR RADIANT STRIP HEATERS



Product Manual



HEATSTRIP[®] Indoor (THS-A)

*The modern, slimline solution for
low cost, efficient indoor heating*





Product Overview

Rev B Jun12

Why choose Heatstrip® electric radiant heaters for your indoor area?

As there is can be significant air movement in an open indoor area, many conventional heaters rely on convection heating which works by heating the surrounding air. This can be quite impractical for these areas, as this heated air can easily be lost, or naturally move to areas where it becomes ineffective (eg. high ceilings). Radiant style heaters transfer heat directly to objects through infra-red waves.

Whilst convection heaters heat the air in between objects, radiant heaters heat the surface of the objects themselves. HEATSTRIP® electric radiant heaters are effective within uninsulated or hard-to-heat indoor area because they provide targeted warmth directly to the people and objects in their path.

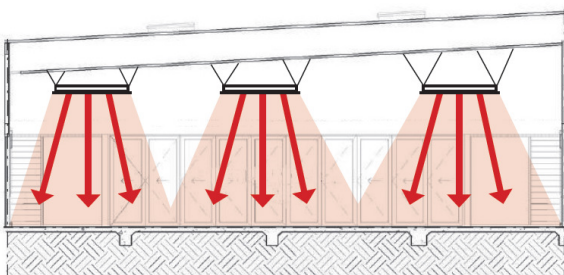

Above: radiant heat is directed downwards to where it is required, and can be zoned to heat only those areas that are occupied.

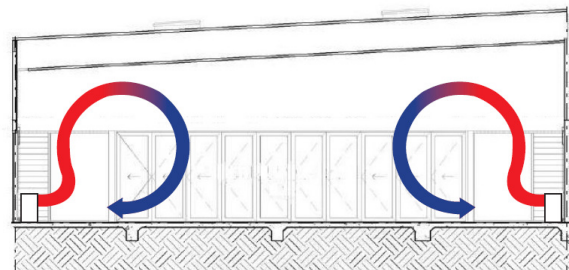

Above: convective heat can be lost in uninsulated areas or naturally rise towards the roof in high ceiling locations.

There are 3 different ranges of products within the Heatstrip® product category. Each has a different temperature specification, making them ideal for different applications. Below is a list of some common applications, to assist with the selection of the most effective and efficient series. This is a general guide only, please refer to the Product Manual for each product, for more information.

HEATSTRIP® Classic (THH models) is a premium high temperature heater and is primarily used for outdoor rooms where there is 1,2 3, or 4 enclosed sides or open indoor area's, with an ideal mounting height of 2.3m to 2.7m.

HEATSTRIP® Max (THX models) is an ultra high temperature heater used for uncovered or open areas with a mounting height of 2.4 m to 3.5m.

HEATSTRIP® Indoor (THS models) is a medium intensity heater used for protected indoor applications.

APPLICATION	THS	THH	THX
Indoor insulated areas: classrooms, offices, bathrooms, wet areas, drying rooms	√	√	X
Outdoor under cover: café, veranda, patio, balcony ceiling height 3m or less	X	√	√
Outdoor under cover: café, veranda, patio, balcony ceiling height up to 3.5m	X	X	√
Exposed outdoor area	X	X	√
Indoor open area: warehouse, factory, production areas, sports facilities	√	√	√
Indoor spot heating: above tables, assembly areas	√	√	√



Heatstrip® Indoor — Features & Benefits

Stylish, Modern, Sleek, Slimline design

The new modern, slimline design of the Heatstrip Indoor makes it the sleekest profile on the market. It will elegantly and seamlessly blend into any indoor environment or décor.

Effective, efficient heating solution for all tough-to-heat, open indoor applications

The innovative design of the HEATSTRIP® enables comfortable and even heat dispersion from the surface with minimal operating costs.

Up to 90% of the heating energy is directed to the area to be warmed, while 10% is emitted as convective heat. This high efficiency ratio means greater heating value.

These medium intensity heaters have an improved water protection rating of IP45 and specifically designed for indoor heating.

Enhanced Heatstrip performance

The HEATSTRIP Indoor design incorporates a unique profile with a high surface area to radiate the heat efficiently and effectively. The enhanced design of the heating panel ensures rapid heat dispersion to provide an ideal indoor comfort heat environment.

Design Flexibility to Meet BCA requirements

4 different models and multiple mounting options within the range allows for the design of innovative heating systems to meet stringent BCA requirements.

Suitable for Multiple Applications — commercial & residential

HEATSTRIP Indoor can be designed to provide comfort heating for a single room or a large stadium, and either a large group or a single person.

Heatstrip Indoor is ideal for a range of applications such as classrooms, lecture halls, sports facilities, shops, factories, churches, restaurant, warehouses, showrooms, childcare facilities, offices, industrial heating, dance & yoga studio's and bedrooms, living rooms, bathrooms etc.

Multiple Mounting Options allows for easy installation

Standard ceiling brackets are supplied, plus optional brackets are available for angled wall mounting, flush ceiling mounting; T-Bar ceiling mounting and chain/wire suspension mounting.

Minimal maintenance

The HEATSTRIP® Indoor incorporates no internal moving parts, ensuring quiet and virtually maintenance free operation.

Australian made

Designed, engineered and manufactured in Australia, the HEATSTRIP® Indoor is fully backed by a 24 month residential warranty, and 12 month commercial warranty.





Specifications - Australia

MODEL	POWER (Watts)	CURRENT (Amps)	DIMENSIONS (mm)	WEIGHT (Kg)	LEAD LENGTH (mm)	PLUG
THS 800A	800	3.3	624 x 235 x 48	4	1000	YES
THS 1200A	1200	5.0	924 x 235 x 48	6	1000	YES
THS 1800A	1800	7.5	1384 x 235 x 48	8	1000	YES
THS 2400A	2400	10	1834 x 235 x 48	11	1000	YES

MODEL	
HEATER TYPE	Medium intensity electric radiant overhead heater with high surface area profiled alloy
OUTPUT	Refer to model code chart above
POWER	230-240 Volts Nominal at 50—60 Hertz, Single Phase
CONNECTION	3 Core Cable 1.5mm ²
APPROVALS	AUSTRALIA/NZ
MOUNTING HEIGHT	MINIMUM 2.1 m RECOMMENDED 2.3 m to 2.7 m MAXIMUM 3.0 m (For higher ceiling heights, units can be lowered using optional bracket kits)
MOUNTING OPTIONS	Suitable for direct ceiling, angled wall, flush ceiling and T-Bar ceiling mounting. Also available for suspension chain mount bracket.
PROTECTION RATING	IP45 Protection from water ingress from all directions
COUNTRY OF MANUFACTURE	Australia

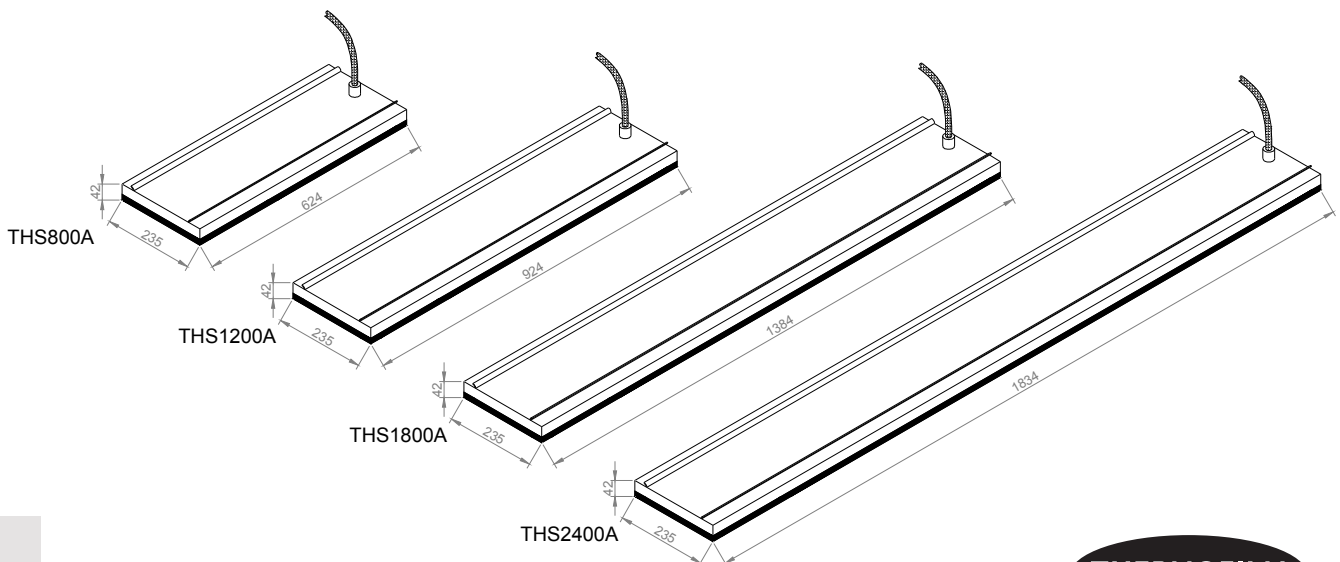



Selection guide

General recommendations for **HEATSTRIP® Indoor**:

- Ideal mounting height: 2.3m to 2.7m. Maximum is 3.0m in an insulated indoor environment.
- Ideal mounting location: ceiling mounted, directly above area to be heated (eg. above a table, seating area etc.)

The below table outlines the coverage of each **HEATSTRIP® Indoor** model (in m²), based on 2 different scenarios. For example, for an indoor area that is protected, Model THS 1800A will cover 12m² and Model THS 2400A will cover 16m².

MODEL	INDOOR INSULATED (m ²)	INDOOR PROTECTED (m ²)
THS 800A	8	5
THS 1200A	12	8
THS 1800A	18	12
THS 2400A	24	16

The above is a guide only and may vary depending on the individual site and conditions.

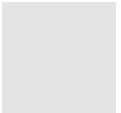



Installation Requirements

The ideal mounting position for the HEATSTRIP® Indoor is on the ceiling, directly above the area to be heated. If this is not possible, HEATSTRIP® Indoor can be mounted on a wall and angled downwards. In this situation, ensure the mounting height is in the range of 2.1m to 3.0m.

- For mounting heights more than 3.0m, we recommend the use of the optional accessories to reduce the height of the heater to 2.3m—3.0m. This will increase the effectiveness of your HEATSTRIP®. Refer to the Mounting Accessory section for more information.
- Electrical connections/GPO's should not be located at the back of the heater. They should be located outside the physical footprint of the units to minimize heat build-up behind the units.
- If the heater is to be mounted on an incline (eg. vaulted ceiling), ensure the electrical connection is located at the lowest point of the heater.

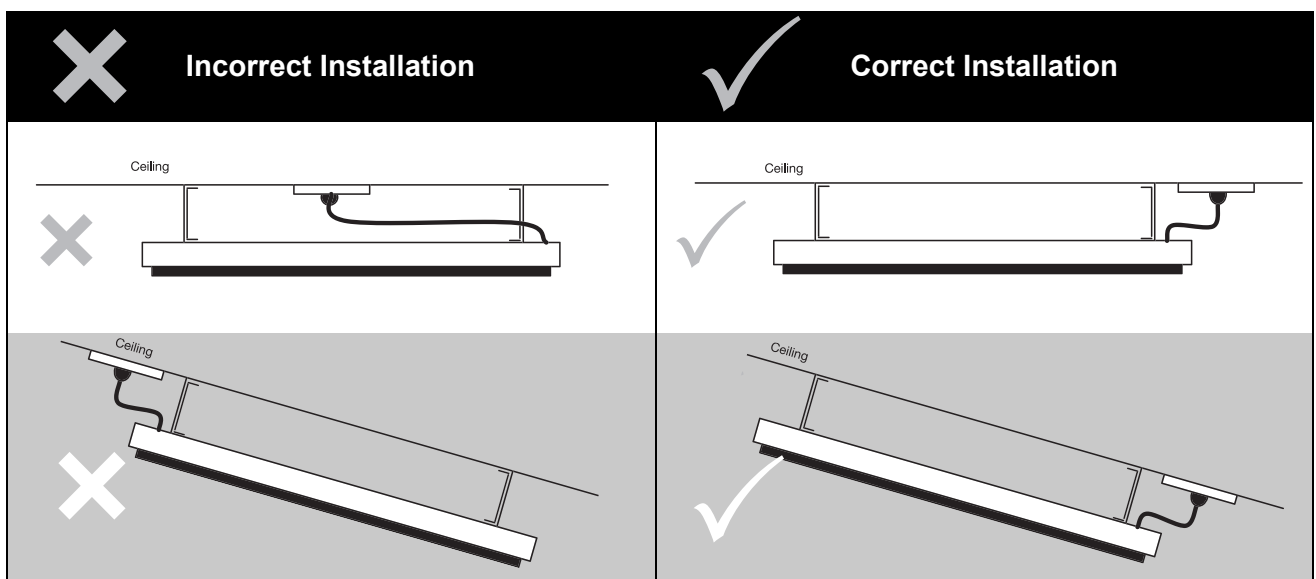

CEILING

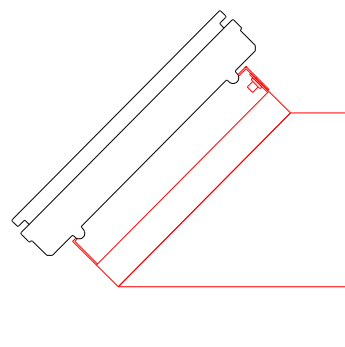

The heating surface must never be directed toward the ceiling



Installation location — the below diagrams confirm the minimum recommended clearances.

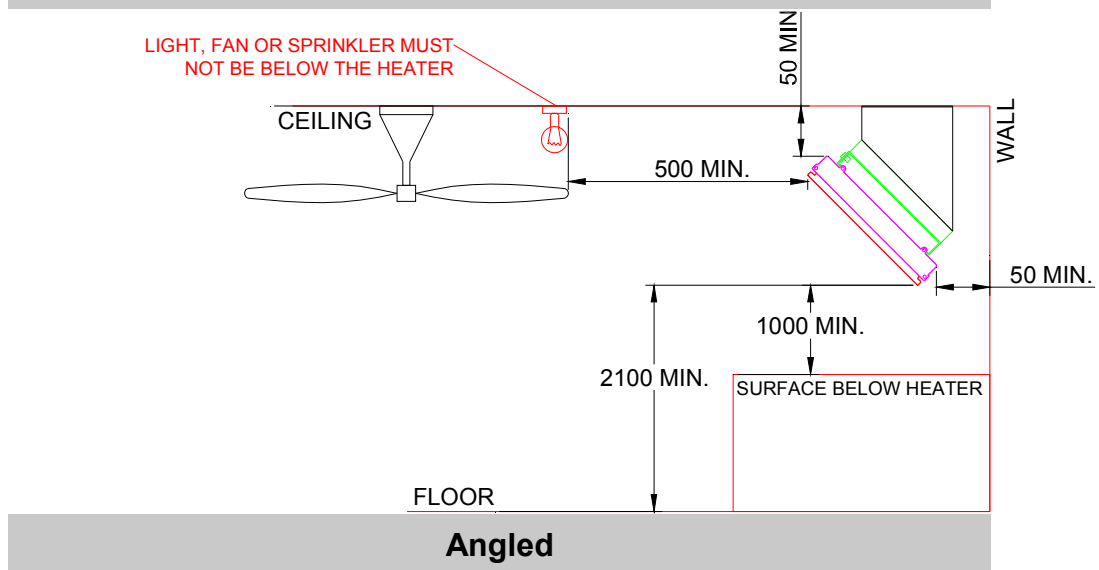
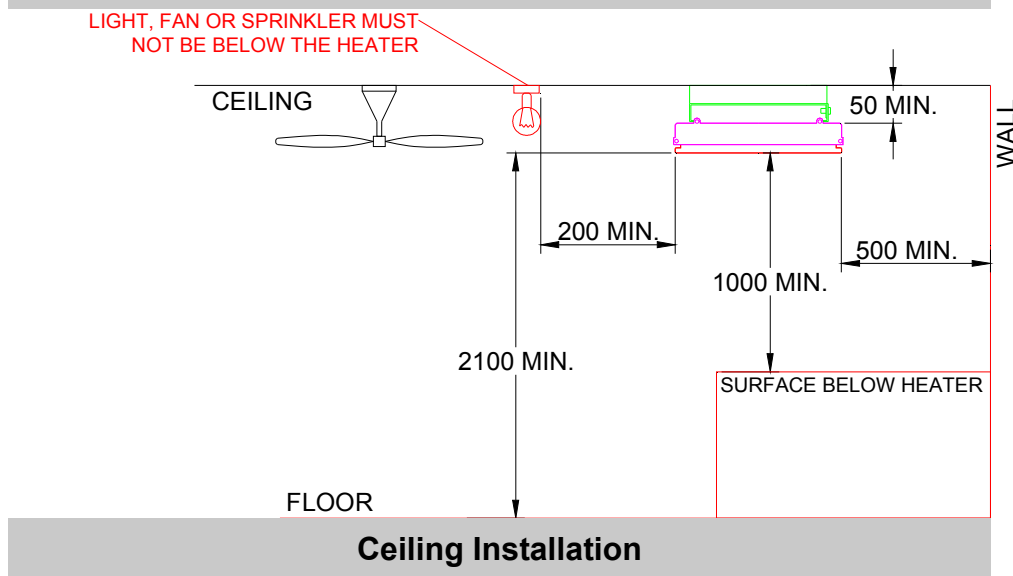
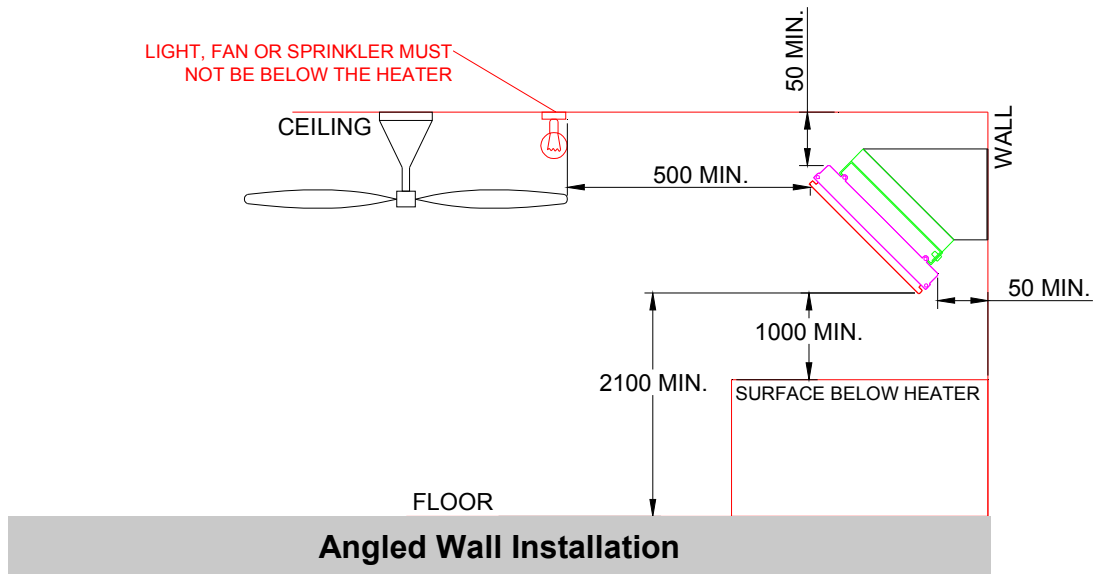



Mounting options

The installation of HEATSTRIP® Indoor is simple and easy with the standard mounting brackets supplied. For other, more challenging locations there are a range of mounting options available - refer to below diagrams.

The HEATSTRIP® Indoor can be mounted directly to the ceiling; angled downwards on a wall; fitted flush with the ceiling; suspended on chains or mounted end-to-end. Refer to the following pages for more detailed information on each mounting option.

CEILING

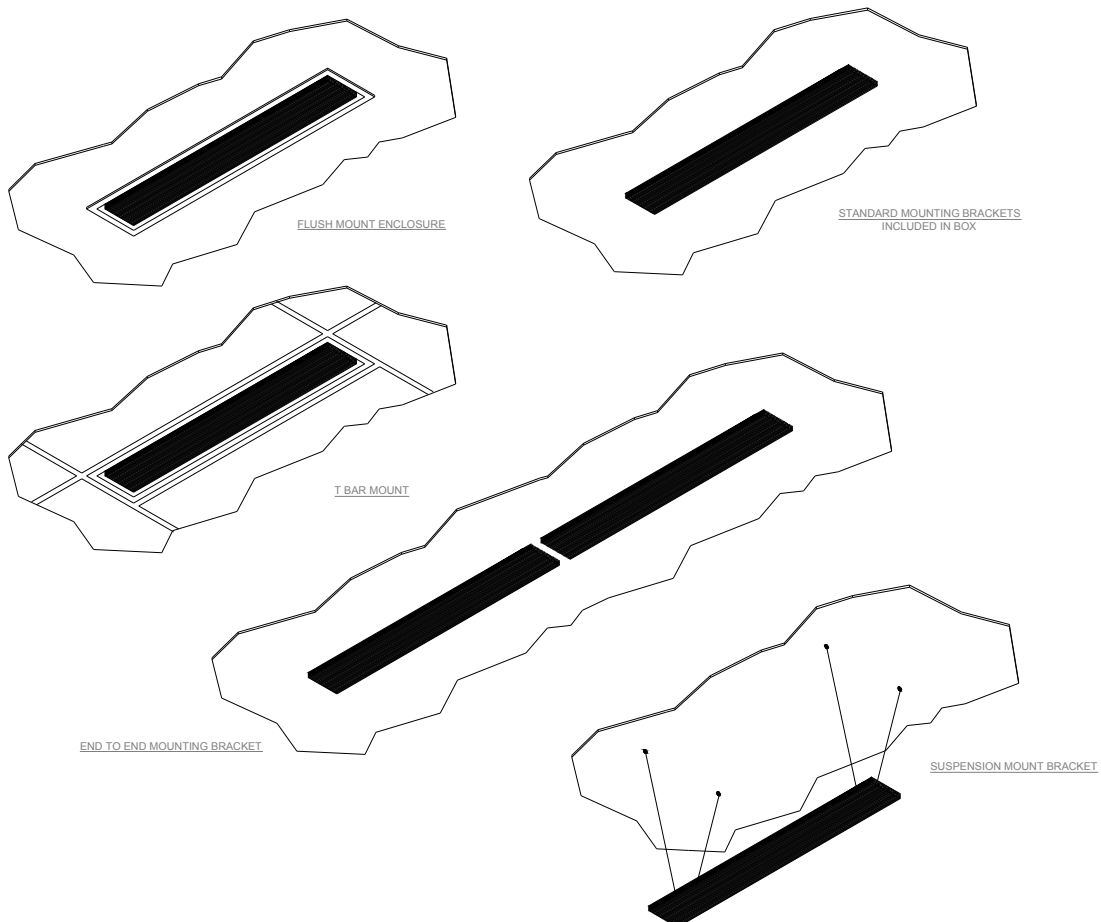
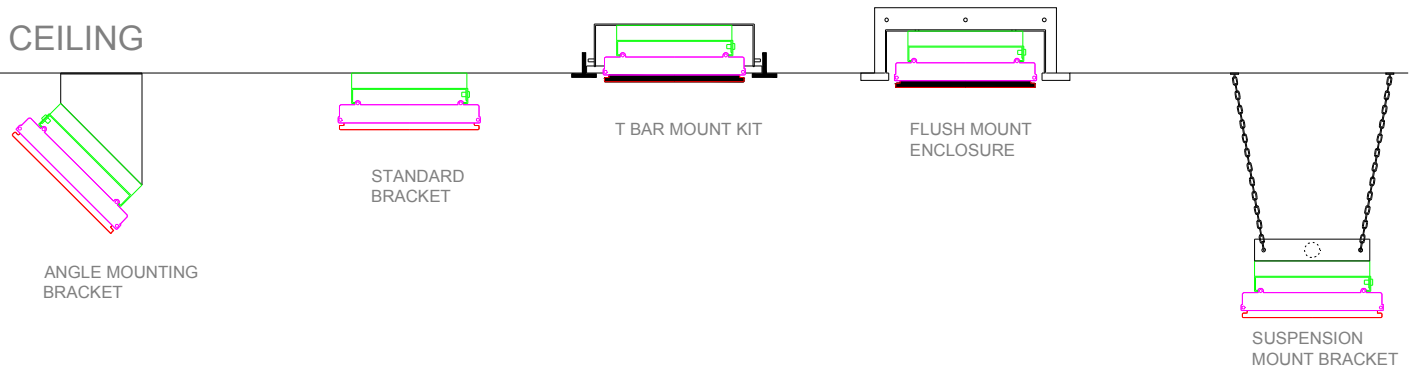



Standard mounting brackets

The HEATSTRIP® Indoor comes with a pair of standard mounting brackets. These brackets allow direct ceiling mount.

The brackets need to be mounted onto a secure frame or ceiling with a minimum distance between the two brackets. The minimum distance ("B") for each model is listed in the table below.

When completing the installation, ensure all screws are tight and unit is secure.

MODEL	"B" MINIMUM DISTANCE (mm)
THS 800A	350
THS 1200A	500
THS 1800A	700
THS 2400A	1000

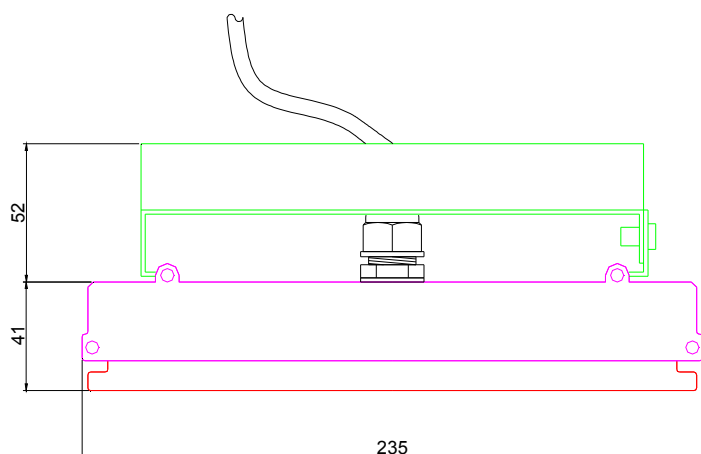
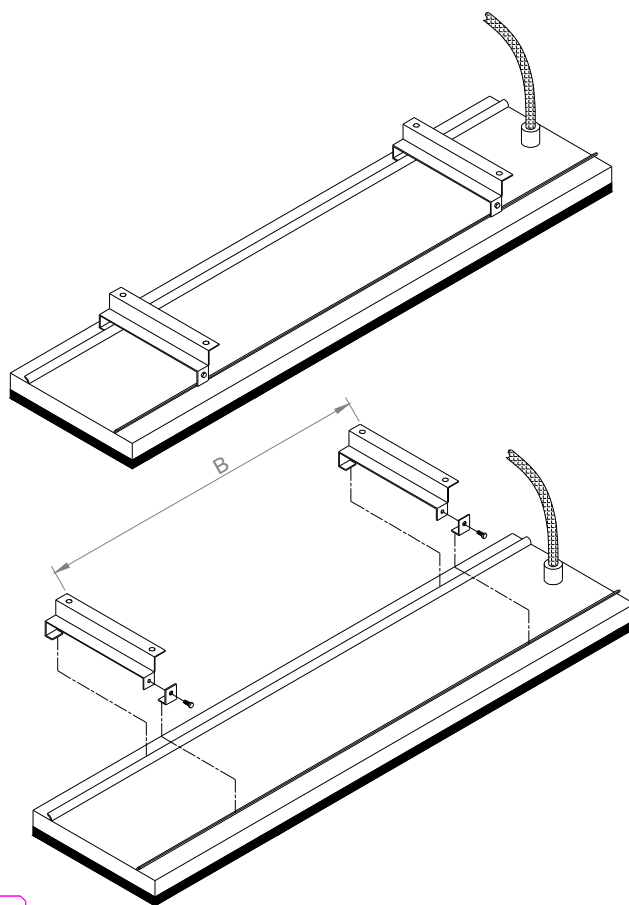

Standard Mounting Bracket

PART No.	PACKAGED DIMENSIONS (mm)	WEIGHT (kg)	MATERIALS
ZBRAK-92	200 x 50 x 50	0.5	MILD STEEL POWDER-COATED WHITE





Angle mounting brackets

The HEATSTRIP® Indoor has optional angle mounting brackets. These brackets can be mounted to the ceiling or the wall to bring the effective heat closer to where it is needed.

The angle of the bracket is preset to 45°.

When installing, ensure that the minimum distances are maintained. Screws are not provided.

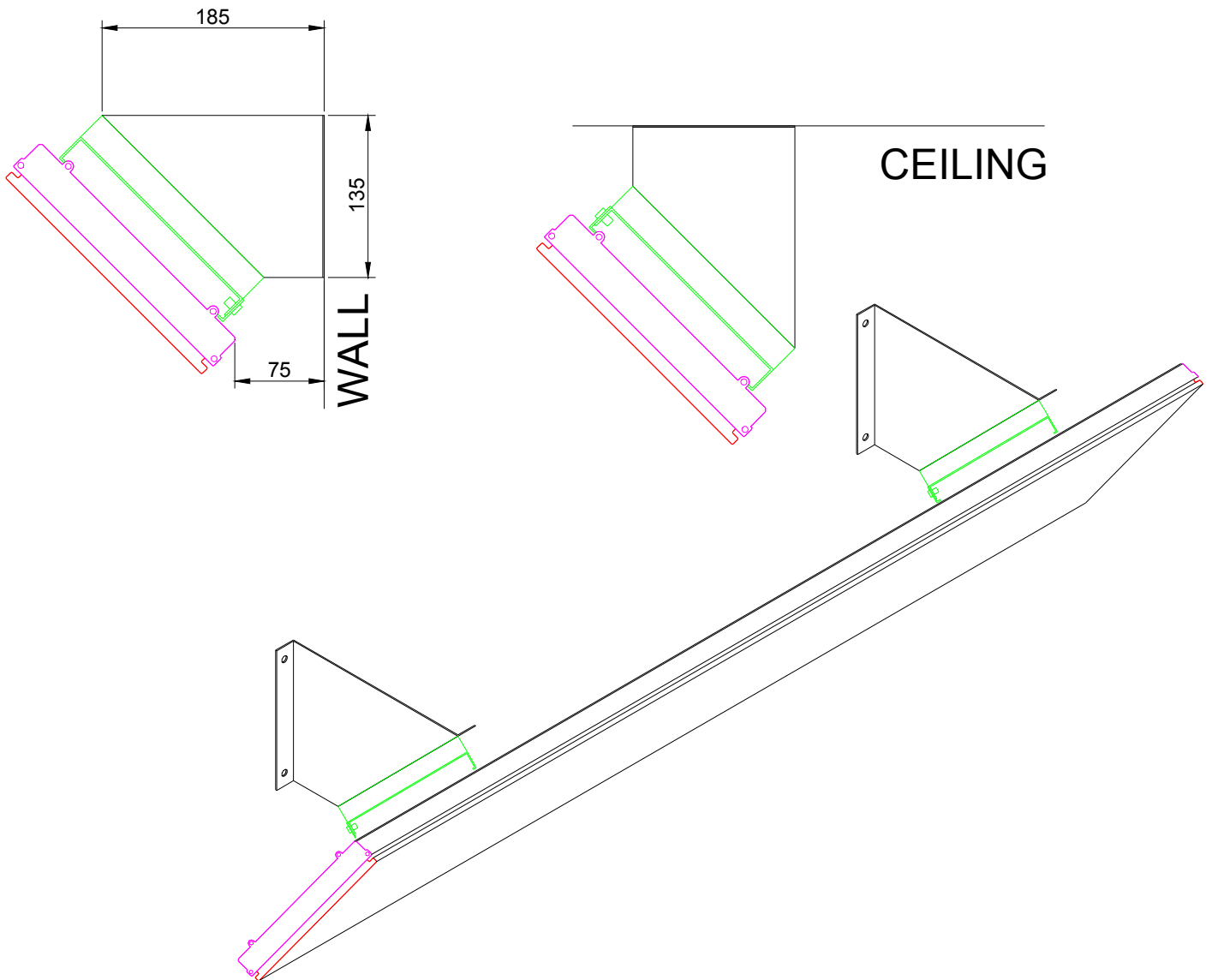

Angle Mounting Bracket

PART No.	PACKAGED DIMENSIONS (mm)	WEIGHT (kg)	MATERIALS
THSAC-020	200 x 200 x 50	0.5	MILD STEEL POWDER-COATED WHITE



Suspension mount bracket

The Suspension Mount bracket provides an easy, efficient and cost effective option for lowering the HEATSTRIP® Indoor from high ceilings. If the ceiling height is more than 3.0m, it is recommended to lower the heaters to an ideal mounting height of 2.3m—2.7m.

The bracket is designed to be used with chains or wires.

There can be multiple chain/wire arrangement options, as per the below diagram.

Note: chains or cable are not supplied with the suspension mount bracket option

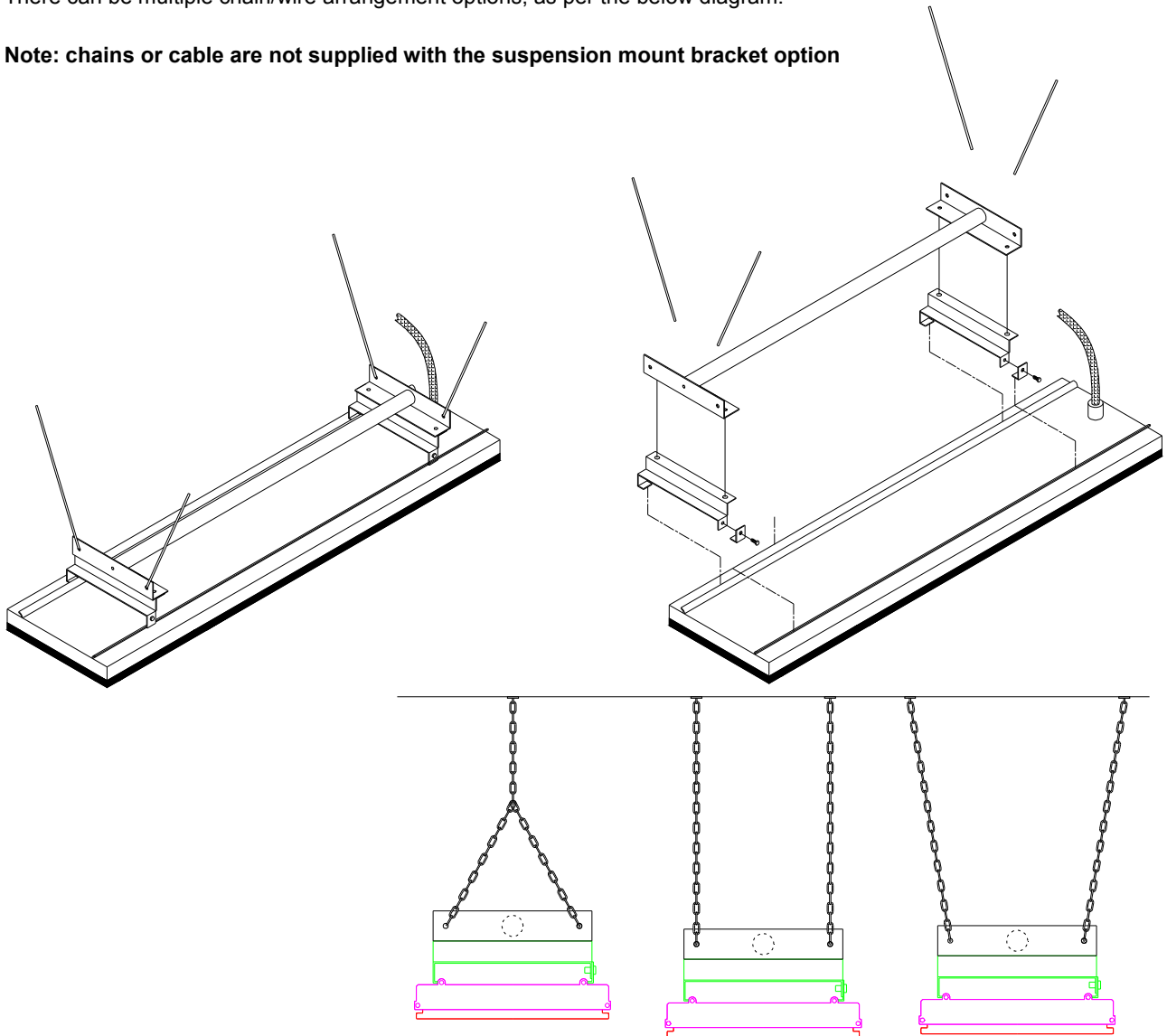

SUITABLE FOR MODELS	PART No.	PACKAGED DIMENSIONS (mm)	WEIGHT (kg)	MATERIALS
THS 800A THS 1200A	THSAC-021	650 x 200 x 50	1.5	MILD STEEL POWDERCOAT WHITE
THS 1800A THS 2400A	THSAC-022	1350 x 200 x 50	2	MILD STEEL POWDERCOAT WHITE



T-Bar Mount

The T-Bar Mount is designed to fit as a half tile into a standard 1200 x 600mm T-Bar ceiling grid. Only Models THS 800A and THS 1200A are suitable for T-Bar mounting.

An ideal mounting height is 2.3m-2.7m, with a maximum ceiling height of 3.0m in an indoor protected environment. Maximum mounting heights should be strictly followed, otherwise the performance of the units may be reduced.

The fascia of the enclosure is manufactured from mild steel powder-coated white in a durable finish.

Please refer to the Installation Manual for more detailed installation information.

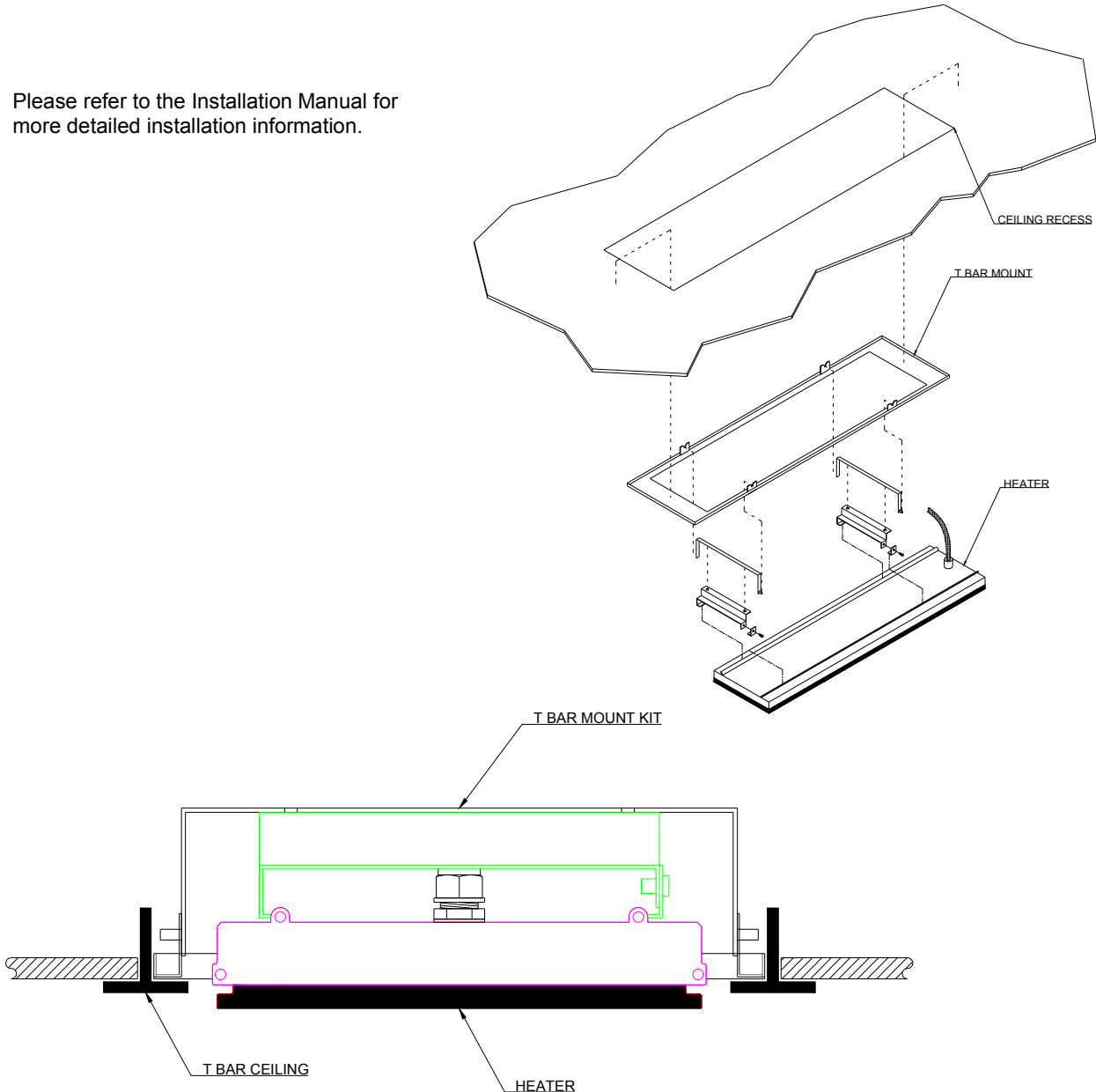

SUITABLE FOR MODELS	PART No.	HOLE CUTOUT DIMENSIONS (mm)	OVERALL DIMENSIONS (mm)	WEIGHT (kg)
THS 800A	THSAC-023	1080 x 280	1090 x 290 x 100	3
THS 1200A	THSAC-024	1080 x 280	1090 x 290 x 100	4



Flush Mount Enclosure

The Flush Mount Enclosure is an ideal way to neatly install the Heatstrip® Indoor into a ceiling. They are available for all Heatstrip® Indoor models, and are supplied as a one-piece unit for mounting of heaters. Flush mounting can be used with plaster or wood lined ceiling materials.

An ideal mounting height is 2.3m-2.7m. Maximum mounting heights should be strictly followed, otherwise the performance of the units may be reduced.

The fascia is made from white powder-coated mild steel.

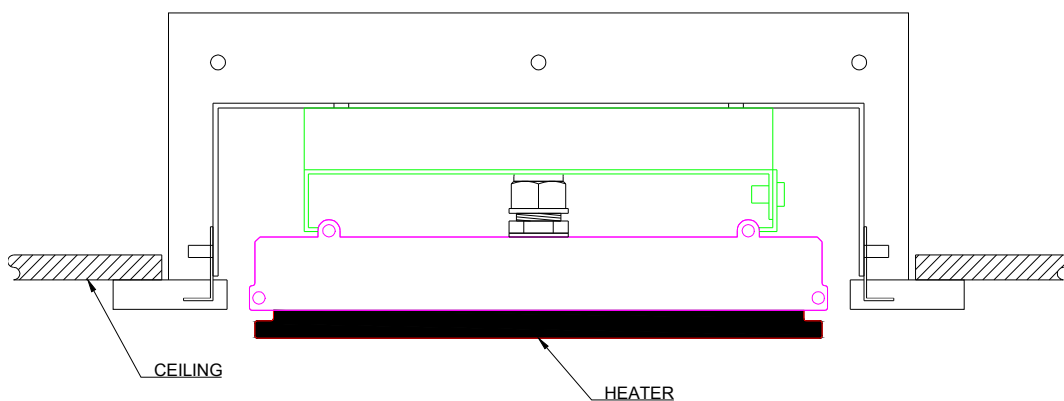
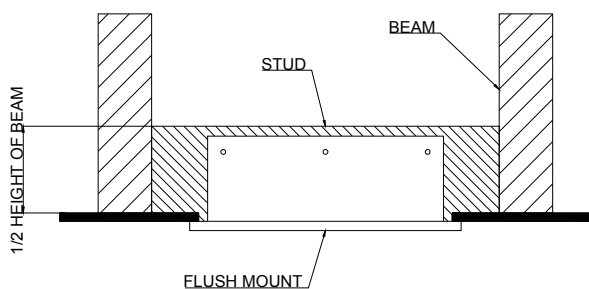
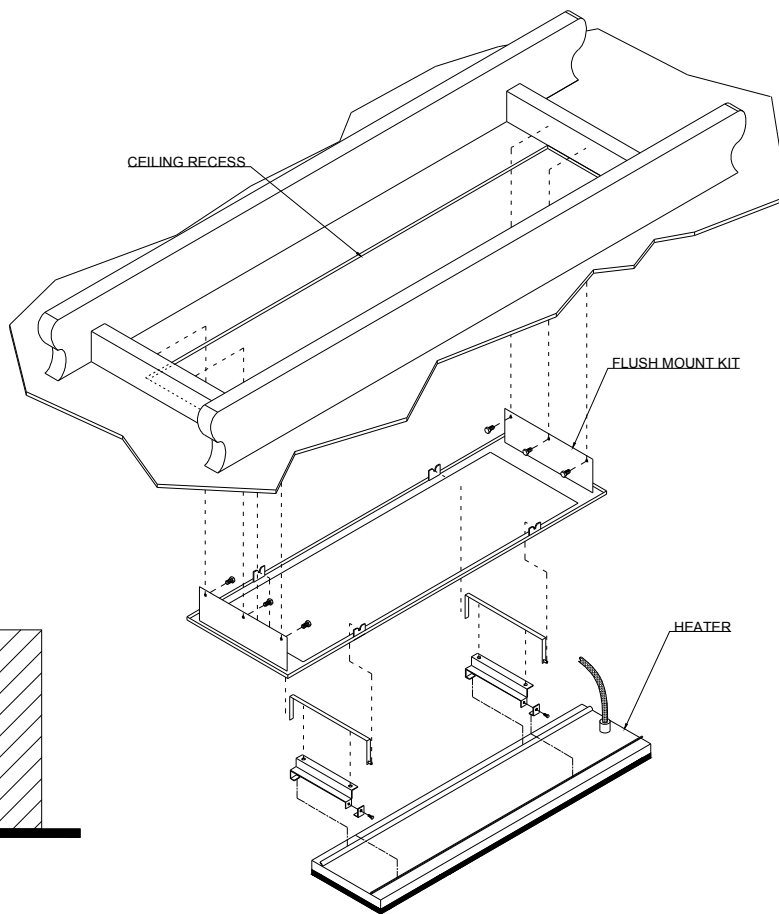

SUITABLE FOR MODELS	PART No.	HOLE CUTOUT DIMENSIONS (mm)	OVERALL DIMENSIONS (mm)	WEIGHT (kg)
THS 800A	THSAC-025	720 x 325	740 x 345 x 100	3.5
THS 1200A	THSAC-026	1040 x 325	1090 x 345 x 100	4
THS 1800A	THSAC-027	1480 x 325	1500 x 345 x 100	4.5
THS 2400A	THSAC-028	1930 x 325	1950 x 345 x 100	5



End to end mounting bracket

The end to end bracket allows multiple units to be joined in a straight line for maximum heat performance and aesthetic appeal. This is ideal for applications such as long rows of tables or seating, where a constant heat coverage is required.

The bracket allows for a 50mm gap between units and an opening for the power connection. As per the diagram below, units should be mounted with the power leads together.

The end to end bracket can be used with the standard ceiling/wall mount bracket, and all models are suitable for end-to-end mounting, including a combination of different models and sizes.

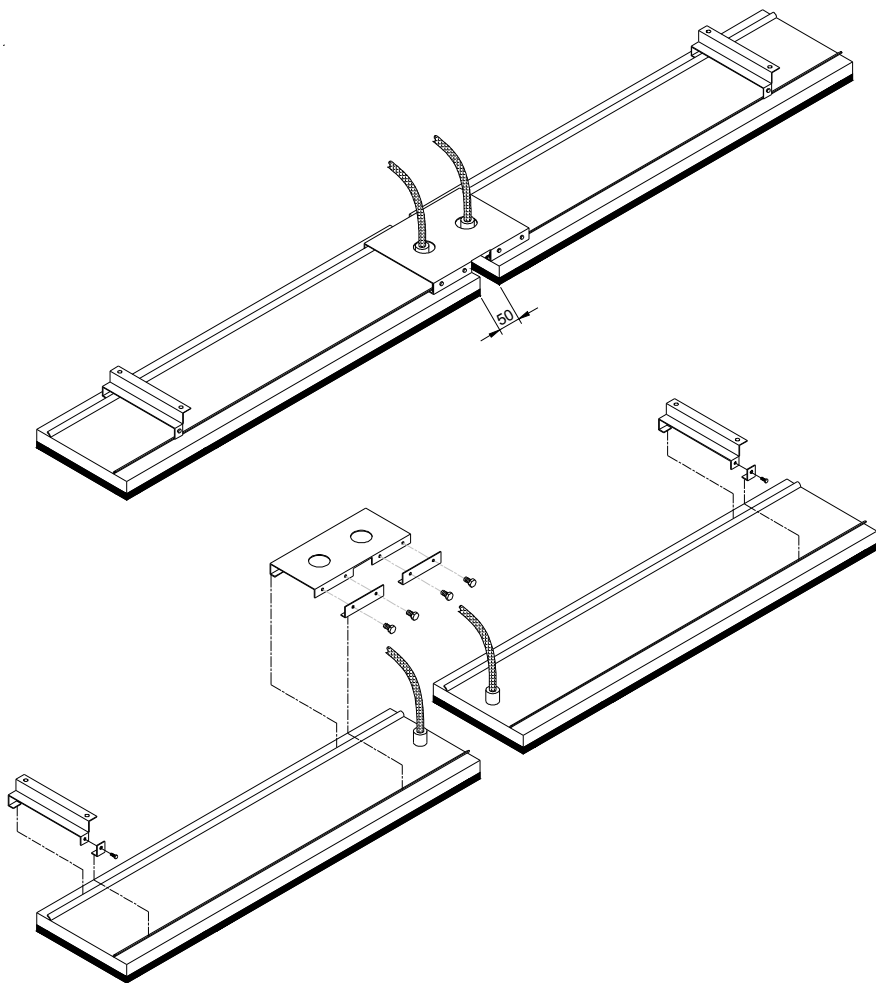

PART No.	PACKAGED DIMENSIONS (mm)	WEIGHT (kg)	MATERIALS
THSAC-029	260 x 200 x 30	1	MILD STEEL POWDER-COATED WHITE



HEATSTRIP® Wall Controller

The HEATSTRIP® Indoor can be controlled via a simple on/off wall mounted switch, however it is recommended to use a controller with a variable heat modulator and a timer, to give the best performance and lowest running cost.

TT-MTM wall controller

This controller is a custom designed and manufactured controller for HEATSTRIP®. It has been designed for ease of use and low running costs of your heater. It provides both temperature control (allowing the user to turn the heat output up or down depending on the ambient temperature and conditions) and a timer for automatic heater operation.

The count down timer function has four settings. It can be 1 hour, 2 hours or 4 hours or constantly on. This is ideal when continuous heat is not required. For example a classroom, church, sports hall, restaurant dining, assembly line production etc. It is simple to use, just press the time button and it will switch on, press again and it will be 1 hour. After one hour the heater will switch off.

Depending on the ambient temperature, there may be a requirement to control the operation of the heater (standard on position is at full power and temperature). The controller has 3 settings, they are High, Medium and Low.

The controller allows a combination of the multiple timer (1/2/4 hour) and heat outputs (High/Medium/Low). The default operation is continuous operation at full temperature.

Controlling multiple units

It is possible to use one wall controller to control multiple heaters. The wall controller is rated at 15 Amps and 240 volts. For larger current draw, it is recommended that you talk to your electrician who can use a time delay relay to connect more units.

The controller needs a minimum of 250W on the load before it starts working. If connecting multiple units ensure one unit is connected directly to the controller and the others are connected using a contactor or relay.

Thermostat controllers

Thermostat controllers are generally NOT recommended for difficult and open indoor heating applications. The temperature sensor for this type of controller is usually measured by the air temperature. The HEATSTRIP® is a radiant heater where objects are heated, not the air. In an open indoor area, it is very difficult to contain warm air within the space and therefore accurately measure air temperature. This may result in unnecessary, continuous operation of the unit.

Thermostat controllers may be used in some well insulated indoor environments, however the location of the thermostat must be considered.

Dimmers

The use of dimmers with the HEATSTRIP Indoor is NOT recommended.

Please refer to the Product Installation Manual for more detailed product data.



MODEL	MAXIMUM VOLTAGE (Volts)	MAXIMUM CURRENT (Amps)	PACKAGED DIMENSIONS (mm)	WEIGHT (kg)
TT-MTM	240	15	140 x 90 x 60	0.5





Safety

HEATSTRIP® Indoor has an IP rating of 45. This means it is safe for water ingress from all directions. The HEATSTRIP® can be safely hosed down.

HEATSTRIP® has undergone extensive testing both in laboratory conditions; in Thermofilm's manufacturing facility in Melbourne and field trials in Australia and overseas. It has been this testing that gives the purchaser the confidence of a high quality product.

Independent laboratory testing has confirmed Thermofilm's full compliance with Australian and other International Standards. This includes CE, AS/ANZ, UL/CSE

All heater models come with a plug. The fixed wiring must be installed by a licensed electrician in accordance with the relevant wiring regulations.

HEATSTRIP® is Class 1 equipment and must be earthed.

In operation, this heater is VERY HOT— do not touch any part of the heater while it is turned on. Do not touch any part until 30 minutes after it is turned off.

This appliance is not intended for use by persons (including children) with reduced physical, sensory or intellectual capabilities, or lack of experience and knowledge, unless they have been given supervision or instruction concerning use of the appliance by a person responsible for their safety. Children should be supervised to ensure they do not play with the appliance.

Do not allow any cables, furnishings, flammable materials or other items come in contact with any surface of the heater.

If installed in wet areas, the heater switches or controls must be located so that they cannot be touched by persons in the bath or shower.

The heater needs to be installed as per the installation instructions paying special attention to the minimum clearances. The heater needs to be mounted on a rigid bracket or fixing.

The heater must not be mounted immediately below or in front of a socket outlet.

In case of a heater fault or damaged supply lead, the appliance should be returned to the point of purchase for return to Thermofilm for repair.

Maintenance

The HEATSTRIP® is made from durable materials, however regular care and maintenance of your heater will help prolong the life of the heater.

It is recommended that you hose down the heater and with a soft cloth gently wipe the surfaces of the heater with a mild detergent to remove the built up contaminants from the environment. Then rinse all detergent off the heater. All chemicals in the atmosphere including cigarette smoke, pollution etc. will tarnish the surface of the heater. In this case, additional cleaning and maintenance may be required. The cleaning process at least every three months will reduce the amount of build up and keep it looking as best it can. If the heater is in a corrosive environment eg. salt spray, we recommend that you clean your heater with a light spray of fresh water every week. After cleaning, turn the heater on for 20 minutes to dry any water residue and prevent water staining.

Before cleaning or inspection activity, the heater must be switched off and cooled down completely.

Do not use any abrasive materials or products to clean the heater, this includes solvents, citrus based cleaners or other harsh cleaning products.

When handling the heater, ensure that your hands are clean or that you use clean gloves as grease or dirt can mark the surface of the heater.

Do not use high pressure water to clean heaters, light water spray only.



Heater wiring schematic diagrams with relays

The HEATSTRIP® heater is required to be fitted with an "ON/OFF" isolation switch and can also be controlled with the use of a timer type control. It is recommended to use the TT-MTM Wall Controller for maximum performance and control options. Ensure the unit is turned OFF after use.

When more heating units need to be connected from the same switch, a relay is needed. It is recommended that you talk to your electrician for more detail.

When using contactors or relays ensure there is a minimum load of 250W on the controller.

Below are some circuits that will help with this situation.

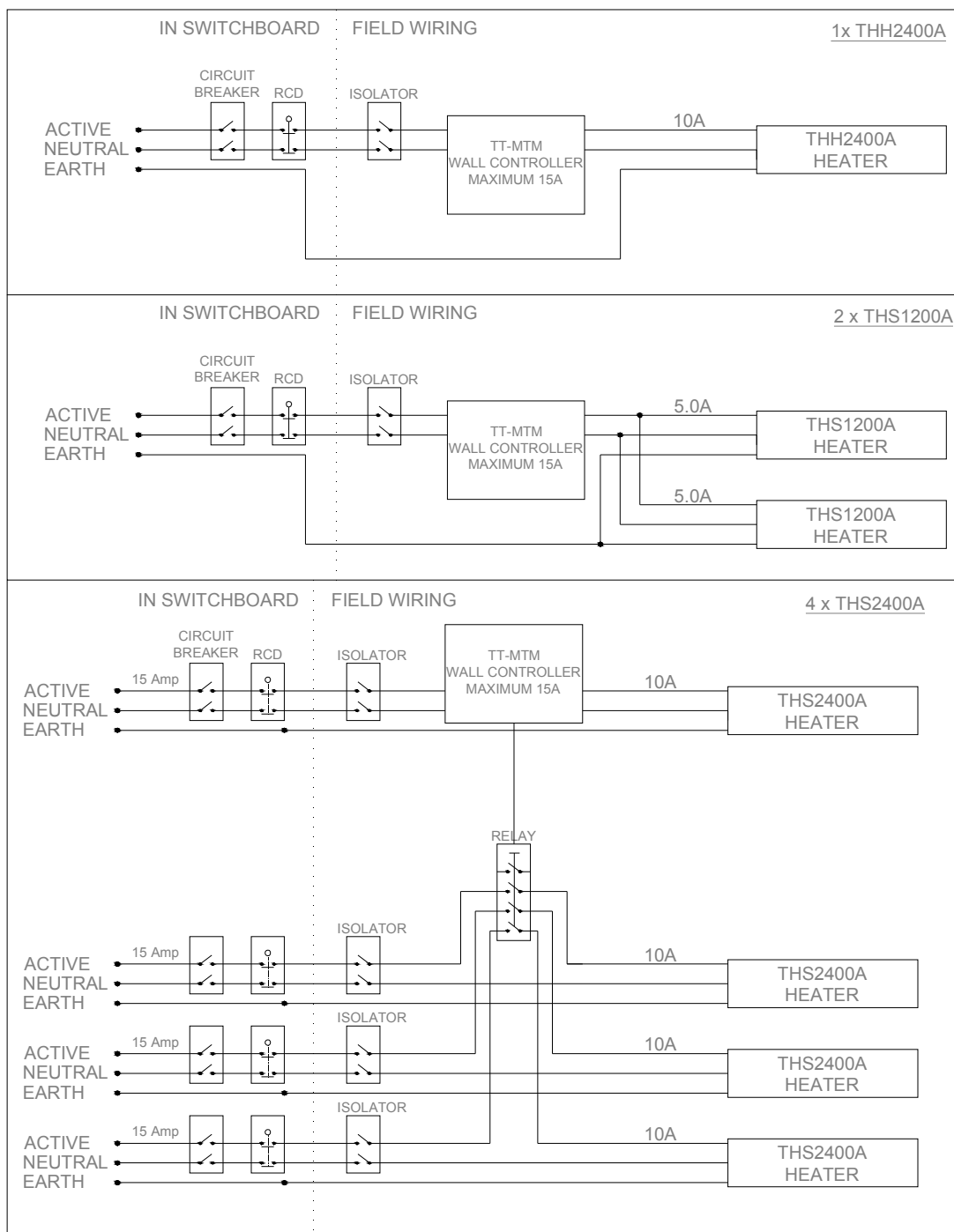



Warranty Terms & Conditions

The below Warranty Terms and Conditions apply for **New Zealand and Australia only**. For international warranty please refer to international warranty terms and conditions.

Thermofilm warrants to the original owner that HEATSTRIP[®] Indoor products will be free from defects in materials and workmanship for a period of 24 months for residential use from the date of purchase in accordance with the following warranty terms and conditions. For commercial use, warranty is 12 months.

Provision of this warranty is subject to:

- The HEATSTRIP[®] product must be installed in accordance with the Installation Instructions and relevant electrical standards and codes.
- The HEATSTRIP[®] product must be maintained and cleaned according to instructions detailed in the Installation Manual.
- There is no warranty expressed or implied with regard to capacity requirements. The selection of the unit or units depends entirely upon the system design and capacities as determined by the purchaser.
- The customer has not repaired, opened or altered the product in any unauthorised manner.
- This warranty excludes damage to the product or components arising from circumstances outside the control of Thermofilm, including, but not limited to, where the product is not used for intended purpose; where the product has been rectified in any way; incorrect installation; incorrect power supply; damaged caused during delivery; misapplication, misuse, abuse, vandalism, lack of maintenance or accident.
- Thermofilm's obligations under this warranty are limited to repair or replacement at Thermofilm's factory of any components of the product which Thermofilm identifies to its satisfaction to be defective.
- Transportation charges involved in return of the product to the Thermofilm factory (or any other location authorised in writing by Thermofilm) is the sole responsibility of the customer.
- All products are inspected and tested before despatch and are at the risk of the purchaser after the shipment from the Thermofilm factory, if not delivered by Thermofilm to destination.
- Discolouration of the surface may occur after a period of time, this does not constitute a warrantable event.
- Twisting and bending of the heaters may occur, this does not constitute a warrantable event.
- No products or components will be supplied in advance of an examination of the faulty product or components by Thermofilm or an authorized representative of Thermofilm.
- Thermofilm does not participate in any site related costs or labour expenses incidental to replacement of parts, repairing, removing, installing, servicing, transportation or handling of parts to complete products, and assumes no liability on parts repaired or replaced without written authorisation. Thermofilm shall not be liable for any default or delay in performance of its warranty obligations caused by any circumstances beyond its control, including, but not limited to, judicial or government restrictions, strikes, fires, floods, abnormal weather conditions, delayed supply of components.

Should products be determined as damaged on arrival, immediately notify the transport company of the condition and have them noted on the freight documents. If damage is discovered after unpacking, demand immediate inspection by the transportation company and insist that a record of the damage is made on the freight documentation.

The customer warrants using the product in accordance with:

- Any instructions provided to it by Thermofilm from time to time.
- All government and local regulations, including but not limited to all relevant electrical, environmental laws and regulations governing the installation, storage, use, handling and maintenance of the goods.
- All necessary and appropriate precautions and safety measures relating to the installation, storage, use, handling and maintenance of goods.

Our goods come with guarantees that cannot be excluded under the Australian Consumer Law. You are entitled to a replacement or refund for a major failure and for compensation for any other reasonably foreseeable loss or damage. You are also entitled to have the goods repaired or replaced if the goods fail to be of acceptable quality and the failure does not amount to a major failure.

All warranty requests for repairs or replacements must be accompanied by a complete "Warranty Claim Form" available from Thermofilm, together with proof of purchase (and where possible, photos of the installation) and the heater returned to the place of purchase.

In the event of a warranty claim, the goods need to be returned to the distributor/retailer for repair/replacement. Contact

Thermofilm Australia Pty Ltd
 27 Rosalie Street, Springvale, Victoria 3171, Australia
 Telephone: (03) 9562 3455,
 Email: info@thermofilm.com.au