



DuPont™ Corian® in Hospitality

CREATING AN UNFORGETTABLE EXPERIENCE



Corian.



ENDLESS EVOLUTION

DuPont™ Corian® in Hospitality





Timeless beauty from an iconic surfacing material

For over 200 years DuPont has pushed the boundaries of innovation for industry, inventing science-based materials and technologies that offer superior solutions and open up new markets.

This track record of successful innovation has made a major contribution – both practically and aesthetically – to a wide range of products, projects and industries around the world. DuPont™ Corian® perfectly exemplifies this contribution. Originally invented to offer a higher performance alternative to conventional surfacing materials, today it is internationally recognised for its impact on the interior design world.

DuPont™ Corian® is renowned for its exceptional versatility, reliability, elegance and almost limitless design possibilities. From bathrooms to spas, bars to wall-cladding, reception desks to lighting, it adds unique value, character and sophistication to the interior design of hotels.

This brochure is designed to give you an overview of the performance characteristics of DuPont™ Corian® and showcase some of its stunning hotel applications around the world. We hope what you see will inspire you to consider DuPont™ Corian® for your next development or refurbishment project.

WHAT IS CORIAN®?

DuPont™ Corian® is an advanced, mineral-filled acrylic material. Homogeneous, with colour going all the way through, it has a distinctive finish and a fascinating interaction with light.

Whatever the nature of your hotel project, DuPont™ Corian® enables complete creative freedom. You can engrave it, form it into virtually any shape, and specify it in a huge range of colours. Whether you envisage undulating curves, organic shapes or bold effects using colour and translucency, you can realise your vision in Corian®.





Above: Sofitel Casablanca Tour Blanche, Morocco; project by Marc Hertrich and Nicolas Adnet; photo courtesy of Deborel Maroc.
Right: The George Hotel, Hamburg, Germany; project by Sibylle von Heyden Innenarchitektur & Design; photo DuPont™ Corian®.



Creating a great first impression

In hotels, first impressions count. Whether it's the reception area or the bedroom, a fresh, clean, welcoming environment can make the difference between a one-time visitor and a regular guest. For over 40 years, designers have been using DuPont™ Corian® in hotels because of its inherent hygienic properties, practicality and design flexibility.

Across the world, Corian® is at the heart of some of the most distinctive and innovative contemporary hospitality and hotel designs. Leading international project designers use Corian® to create environments that are beautiful, ultra-functional and offer the height of comfort for hotel guests.

Imagine a long, curved reception desk...a statement bar...a vanity top with integrated washbasins...a fitted shower...an ergonomic kitchen plan... almost anything is possible with DuPont™ Corian®. Its unique properties allow designers to play with shapes and adapt the material to any space.

The thermoformability of Corian®, and the fact that it is available in more than 65 colours (with customised colours as an option), enables design possibilities that cannot be achieved using natural stone products. Combining beautifully with other materials, Corian® blends into any environment, from classic to contemporary, simple to highly exclusive.



Good looks that withstand daily hotel life

HYGIENIC AND EASY TO CLEAN

Cleanliness is all-important in every area of a hotel...with the reverse being the first thing many guests will notice. Corian® is recognised for its unique hygienic properties. Solid and non-porous, it is joined with inconspicuous seams, creating surfaces that are both elegant and easy to clean. This makes it the perfect solution for spas, beauty salons and wellness areas, as well as for guest and public bathrooms.

Hotel owners naturally want to keep cleaning time to a minimum in order to reduce costs and disruption. With Corian®, washbasins are integrated with inconspicuous joints, so there are no awkward corners where dirt or humidity can accumulate. Corian® is exceptionally quick and easy to clean using common household products and, provided it is properly cleaned, will not support the growth of mold and mildew.

A DURABLE SOLUTION

Corian® is durable, non-porous and does not delaminate. It is also stain-resistant and scratch-resistant. If scratches and cigarette burns do occur, they can easily be removed, while more major damage can be repaired on site, minimising the time that rooms are out of service.

Left: Percy Kildwick Golf Club in York, UK; photo Jake Fitzjones.
Below: W Barcelona Hotel, Spain; project by Ricardo Bofill; photo Francesc Bedmar.
Right: Sofitel Casablanca Tour Blanche, Morocco; project by Marc Hertrich and Nicolas Adnet; photo courtesy of Deborel Maroc.





Left: Gamaritz Hotel, Biarritz, France; photo courtesy of Composite Système.
Below: Holiday Inn Vaugirard Hotel, Paris, France; photo Jean-Pierre Delagarde.
A 'before' and 'after' renovation in a bathroom at the Holiday Inn, Vaugirard (Paris). By using Corian®, it was possible to refurbish the bathroom without needing to strip the entire space.



Improving your guest experience with an inviting new bathroom

MADE-TO-MEASURE BATHROOM REFURBISHMENT SOLUTIONS

However many bathrooms you want to refurbish – from a single unit to a hundred or more – DuPont™ Corian® provides the ideal answer. Your preferred design solution can be adapted to the exact dimensions and room layout required, ensuring a perfectly fitted bathroom that is very easy to clean.

With Corian®, designers can create a guest bedroom that offers an inviting cocoon for the weary traveller. The material can be shaped to cover the walls of a shower room, seamlessly integrating useful details such as soap holders and shelves, or moulded to form stylish, distinctive vanity tops. With its pure lines and huge range of colours, Corian® offers countless design possibilities. It also blends beautifully with wood, stainless steel and glass.

Whether your guests opt for a revitalising shower or a relaxing bath, Corian® ensures that the experience will leave a lasting impression.



Hotel Mercure Paris Centre Tour Eiffel, Paris, France; photo Stefan Kraus, courtesy of Accor.

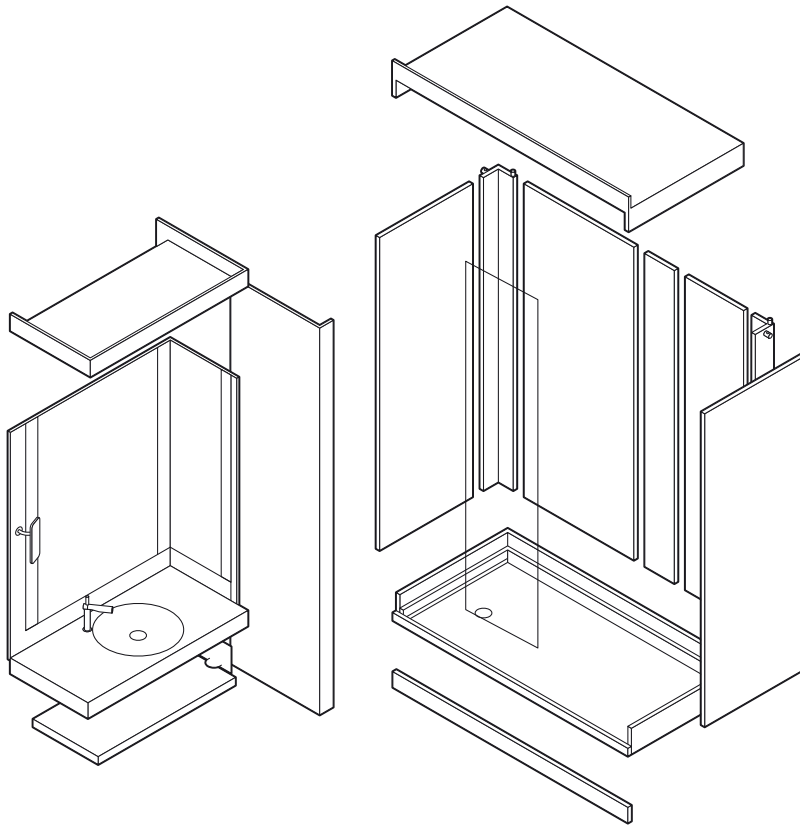

Rapid refurbishment to minimise ‘out of use’ time

For any hotel, profitability relies on maximum occupancy, so reducing ‘out of use’ time is a crucial consideration when refurbishing. With this in mind, DuPont™ Corian® is an excellent solution for hotel bathroom renovations. Thanks to an ingenious ‘easy to assemble’ system promoted by Corian® in collaboration with specialist sanitary technology companies, hotel owners can implement a total refurbishment of their bathrooms quickly and cost-effectively.

The system, which includes a ceiling, wall partition, shower cladding and vanity, is fitted without removing the original surfacing material and can be assembled within a short space of time since the elements are delivered ready-made. This solution can be installed in any configuration and, because the material is joined seamlessly, provides a high level of hygiene with no danger of seals deteriorating over time. It can also fit any design or tight space.

Already implemented by a major hotel chain for the redevelopment of around 10,000 of its bathrooms, this system offers significant cost savings compared to traditional refurbishment solutions by minimising ‘out of use’ time and dramatically improve the hotel experience for guests.



Left: Dinner club in Wien, Austria; project by Söhne&Partner; photo Severin Wurning.
Right: Esperanto washbasin and mirror by Rexa Design, "Corian® 2.0" (Milan week of design); design by Monica Graffeo; photo Leo Torri.



Intense, dark colours that are easy to maintain

While dark colours offer impact from a design point of view, in the past they have been less practical than white or light colours since scratches are always more visible on dark surfaces. However thanks to DuPont's new DeepColour™ Technology*, Corian® has recently launched a range of intensely dark colours that offer improved wear performance and easier thermoforming, seaming and finishing.

This means that designers and architects can specify dramatic dark tones that were previously inadvisable for heavy traffic environments, and hotel owners can rest assured that these colours will be easier to maintain.

The first DeepColour™ Technology* collections consist of four intense black hues (Deep Anthracite, Deep Black Quartz, Deep Night Sky, Deep Nocturne, Deep Cloud and Deep Titanium)

* Patent pending

Bedside tables by Linak featuring an integrated wireless device for recharging smartphones; design by Hans Sandgren Design; photo Sanne Berg Thunøgade Århus.



DuPont™ Corian® with embedded technology

THE ULTIMATE IN HI-TECH CONVENIENCE AND STYLE

Charging mobile phones and tablets in hotels is a perennial problem for travellers, requiring them to locate the correct charger, find a power socket and, if abroad, a country adaptor too. Opening up a new world of convenience, DuPont™ Corian® advanced surfaces with built-in wireless capability enables guests to charge their smartphones or tablets simply by placing them on a DuPont™ Corian® countertop.

This wireless charging solution can be effectively integrated into almost any Corian® application – from lounge tables to bedside tables, guest rooms to public spaces – simplifying guests' lives and providing a neat, high-tech, novel solution.



DYNAMIC LEDWALL: PLAYING WITH LIGHT AND CUSTOMISED CONTENT

The Ambium® Dynamic LEDwall from Koledo brings interior spaces to life by combining DuPont™ Corian® with lighting and dynamic digital content.

The wall, made in white DuPont™ Corian®, is lit by multi-coloured LEDs integrated behind the material, and delivers content that can be customised according to the requirements of each specific environment. This unique combination of sensory experiences makes for endless possibilities, whether used to set a mood, provide entertainment, or enhance your corporate identity. However you choose to use it, the Dynamic LEDwall is the perfect way to attract, inspire, surprise and delight your guests.



Top: Esperanto washbasin by Rexa Design, "Corian® 2.0" (Milan week of design); design by Monica Graffeo; photo Leo Torri.
Bottom: Ambium® Dynamic LEDwall by Koledo, "Corian® 2.0" (Milan week of design); photo Leo Torri.



Poncelet Cheese Bar. Madrid, Spain; project by Gabriel Corchero; photo Pasquale Caprile.

Vibrant, memorable restaurants and bars

Restaurants and bars are the places where customers relax and socialise – and where hotels can create an exciting ambience that brings guests back time and time again.

Corian® can be adapted to suit all forms of dining and entertaining requirements. Tabletops in Corian® satisfy the most demanding standards of hygiene while offering a stylish, sensuous backdrop for enjoying delicious dishes, fine wines and sophisticated cocktails. Beyond table and bar tops, Corian® wall surfaces can help create a relaxed or more dramatic atmosphere.

With a huge range of colours and design possibilities to choose from, Corian® enables hotel owners to create an intimate, inviting ambience in a boutique hotel or maintain a strong brand presence across an entire chain.



W Barcelona Hotel, Spain; project by Ricardo Bofill; photo Francesc Bedmar.

A worthwhile investment

A unique and versatile material, DuPont™ Corian® has higher initial production costs compared to some in-kind alternatives. However it pays to look at the bigger picture. As confirmed by the world's leading hotel chains, DuPont™ Corian® solutions offer lower costs in terms of maintenance and cleaning, repair or replacement, and project refurbishment costs, including 'out of use' room time during installation. This means that in the long-term, Corian® offers an excellent return on investment.



WE ONE

Panipouran Duck
\$11.8

键善

键善

Signature Duck



Left: Inamo restaurant, London, UK; design by Blacksheep Architecture and Design; photo Francesca Yorke.
Above: Percy Kildwick Golf Club in York, UK; photo Jake Fitzjones.





Kind to the environment

DuPont™ Corian® (either as a brand or specific products) has received significant independent certifications for its environmental performance (such as GreenGuard®, NAHB North American Builders Association, U.S. Green Building Council's LEED® Green Building Rating System, Scientific Certification Systems, and Ecospecifier). The material's hygienic performance has also been certified by prestigious independent institutions.

The environmental management systems of all the DuPont plants that produce DuPont™ Corian® have been certified according to ISO 14001. In addition, as a result of a multi-year improvement program, all DuPont plants that manufacture DuPont™ Corian® have brought their impact on landfills down to zero by reducing, reusing and recycling manufacturing by-products and waste.

Left: Zenden Hotel, Maastricht, The Netherlands; project by Wiel Arets Architects; photo courtesy of Zenden Hotel.
Above: Hotel Hampton by Hilton, Gdansk, Poland; photo DuPont™ Corian®.





Left: Hotel Sofitel Brussels Belgium; project by Antoine Pinto; photo courtesy of Sofitel.
Top: Harvey Nichols Fifth Floor bar, London, UK; project by Shaun Clarkson ID; photo Jake Fitzjones.
Bottom: Dinner club in Wien, Austria; project by Söhne&Partner; photo Severin Wurning.

Technical information

DUPONT 10 YEAR WARRANTY ACROSS AUSTRALIA

In addition to the DuPont 10-year Product warranty, all installations fitted by a member of the Corian® Quality Network in accordance with the installation procedure in force at the time of the installation are covered by a ten (10) year Limited Installed warranty.

	DUPONT™ CORIAN® 12 MM THICKNESS	NATURAL STONE AND GRANITE	ENGINEERED STONE
HEAT	Resistant to heat*	Cracking in case of thermal shock	Good heat resistance
IMPACT	Good resistance to mechanical impact	Heavy and brittle	Heavy and brittle
HYGIENE	Non porous	Porous. Lack of resistance to stains and acids. Poor in terms of hygiene	Poor hygiene due to seams
CLEANING	Easy to clean thanks to inconspicuous seams*	Demands maintenance (sealing)	Sensitive to bleach
RENEWABILITY	Can be repaired to the original look	Cannot be repaired	Cannot be repaired
SEAMING	Inconspicuous seams enable a monolithic effect between bowl, backsplash and worktop	Visible seams (sealant)	Visible seams (sealant)
COLOURS	Large colour palette	Random colours	Sensitive to UV: colour fading. No solid colours
AESTHETICS	Silky touch. 3D design versatility enables unique designs and shapes	Stone touch. Fabrication of curves or rounded shapes is very expensive	Cold touch. Fabrication of curves or rounded shapes is very expensive
WARRANTY	10-year limited installed warranty covering fabrication and installation (conditions apply)	After sales service may be provided by supplier	After sales service may be provided by supplier

* Please refer to Corian® Use & Care guidelines.

CONCRETE	GLASS	STAINLESS STEEL	LAMINATE
Good resistance, but possibility of discoloration	Very sensitive to thermal shock	Heat can cause expansion of the material	Blistering and discolouration risk when exposed to heat
Fragile in case of mechanical impact	Fragile in case of mechanical impact. Noisy surface	Will indent in case of impact	Resistant to impact, but sensitive to humidity
Porous	Poor hygiene due to seams	Hygienic	Poor hygiene due to seams. Lack of resistance to acid stains
Difficult to maintain	Sensitive to abrasive cleaning products	Demands high level of maintenance (due to fingerprints, water)	Easy to clean
Hard to repair	Scratches cannot be removed	Cannot be repaired (as it is one single sheet)	Cannot be repaired
No seams, but difficult to install	Visible seams (silicone)	Single piece requires very expensive fabrication	Visible seams. Risk of water infiltration between worktop and bowl
Very limited colour choice. Random colour rendering	Limited colour choice - only solid colours.	Only one colour choice	Large colour palette
Cold touch	Cold touch. Reflects light. Limited creative solutions	Develops patina over time	Very limited design options
After sales service may be provided by supplier	After sales service may be provided by supplier	After sales service may be provided by supplier	After sales service may be provided by supplier

Chemical resistance of Corian®

The following reagents show no permanent effects on a Corian® surface when left in contact for a period of 16 hours.

The chemical residues can be removed with a wet Scotch-Brite™ pad and bleaching cleanser. Sometimes, minimal effects have been observed, particularly those indicated by footnotes (** and ***).

Acetone **	Hair dyes	Salt (sodium chloride)
Ammonia (10%)	Household soap	Soapless detergent
Ball point pen	Ketchup	Soy sauce
Bleach (household type)	Lemon Juice	Sugar (sucrose)
Blood	Lipstick	Tea
Cigarette (nicotine)	Liquid shoe polish	Tomato sauce
Coffee	Mercurochrome (2% in water)***	Urine
Cooking oils	Mustard	Vinegar
'Dry bond' dental adhesive	Nail polish	Washable inks
Eosine	Olive oil	Wine (all varieties)
Food colouring	Pencil lead	

** May cause slight lightening after 16 hours' exposure

*** May cause slight darkening after 16 hours' exposure

Royal Christiania Hotel, Oslo, Norway; photo courtesy of Royal Christiania Hotel.



The information contained in this brochure is given free of charge by E.I. du Pont de Nemours and Company Inc. or its affiliated companies (collectively, "DuPont"). It is based on technical data which DuPont believes to be reliable and is intended for use by persons having knowledge of this technical area at their own discretion and risk. DuPont assumes no responsibility for results obtained or damage incurred from the use of the information contained in this brochure either in whole or in part by the fabricator, the architect, or the designer, or the owner, or the user of DuPont™ Corian® sheets nor shall DuPont be liable in case of non-compliance with the applicable government regulations or in the event that DuPont™ Corian® sheets are applied in violation of the applicable government regulations.

More specifically, we do not approve or disapprove any designs or drawing submittals or assume any liability for the design selected. Any and all liability for a design rests with the architect, or the designer, or the owner, or the user, based on whatever contractual arrangements have been made. Moreover, the information in this brochure does not contain any warranties, except to the extent expressly provided otherwise herein.

In addition to the DuPont 10-year Product warranty, all installations fitted by a member of the Corian® Quality Network in accordance with the installation procedure in force at the time of the installation are covered by a ten (10) year Limited Installed warranty. For more details, please refer to the general terms and conditions of the ten (10) year limited warranty. We believe all information in this publication to be correct at the time of publication. It is intended as information concerning our products and their application possibilities and is therefore, not intended as any form of warranty with regard to any specific product characteristics, except to the extent expressly provided otherwise herein.

casf
your space your way

www.casf.com.au

1300 267 426

The DuPont oval logo, DuPont, Corian®, Endless Evolution and the Endless Evolution logo are registered trademarks or trademarks or copyrighted material of E. I. du Pont de Nemours and Company or its affiliates. Only DuPont produces Corian®. Other logos, registered trademarks and trademarks are property of their respective owners. Copyright © 2016 E. I. du Pont de Nemours and Company or its affiliates. Close-ups of washbasins, photo Riccardo Bianchi for DuPont™ Corian®. All rights reserved. No copy or extraction of its content is authorised. This document is protected by all applicable laws on copyright and intellectual property.

Cover: Hotel Sofitel Brussels Belgium; project by Antoine Pinto; photo courtesy of Sofitel.



Corian.