

Insulated Roof & Wall Panels
Australia

KS1000RW Trapezoidal Wall Panel Installation Guide

Horizontally Laid

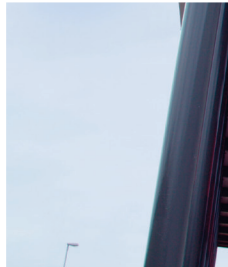

KS1000RW Trapezoidal Wall Panel

Horizontally Laid

Components

KS1000RW Trapezoidal Wall Panel

Factory Applied Weather Seal (FAWS)



Primary fastener with washer
(Carbon Steel)
(Not by Kingspan)

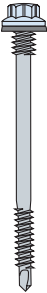

Stitching screw with washer
(Carbon Steel)
(Not by Kingspan)



Low profile fastener
(Carbon Steel)
(Not by Kingspan)

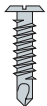

Fire rated canister foam
(Not by Kingspan)



Neutral cure gun-grade butyl sealant
(Not by Kingspan)



External corner flashing



Drip flashing



Continuous base support angle

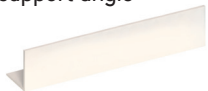

Butyl tape sealant
(Code: SEXT)



6x4mm

Profiled Ridge Filler (Code: 3RWFill)



PIR insulation
(Not by Kingspan)



This installation guide should be read in conjunction with the 'project specific' design drawings and method statements. Although this installation guide is deemed to be correct at the time of publication, Kingspan reserve the right to amend the information at any time in the future. Installation Guides are available for the full range of Kingspan Insulated Roof, Wall and Facade Systems.

KS1000RW Trapezoidal Wall Panel

Horizontally Laid

Notes:

- Ensure steelwork is suitably lined, levelled and within tolerance.
- The end lap support position is critical, check location and straightness.
- Cover plates required where gap in support steel is greater than 20mm.
- All fasteners to be Carbon steel to maintain panel warranty
- Gun-grade sealant type - neutral cure gun grade butyl sealant.
- Minimum bearing face for vertical joint supports 100mm or 140mm if vertical top hat alternative is being use (See page 9).
- Minimum bearing face for Intermediate supports 50mm.
- There are several types of vertical joint. This guide shows the use of a panel overlap joint detail. See page 9 for top hat alternative.
- Number of fasteners must be calculated based on project spans and wind loads.
- See specific details for high humidity applications.
- Panels to be installed on horizontal sequences first before proceeding to rows above.
- Continuous run of 6x4mm butyl sealant to be installed around entire perimeter of panel installation
- Clean swarf off panels immediately when created.
- Ensure panel joints are pulled tight to adjacent panels to close any gaps as works progress.
- This installation guide provides generic guidance on installation methods, however, should be read in conjunction with project specific specifications and construction details.
- Install fasteners with recommended screw gun speed selection for type of steel, use correct socket and drive bit, including depth – locating nose piece, unless fastener has feature to prevent overdriving, in line with fastener manufacturers.



Please contact Kingspan Technical Services Department for guidance:

- Internal air seals
- High humidity & hygiene internal environments
- Project specific advise

KS1000RW Trapezoidal Wall Panel

Horizontally Laid

SIDELAP
A Factory Applied Weather Seal (FAWS) is applied to the panels, on the under side of the sidelap, before they leave the factory.

Sidelap rotated 180°

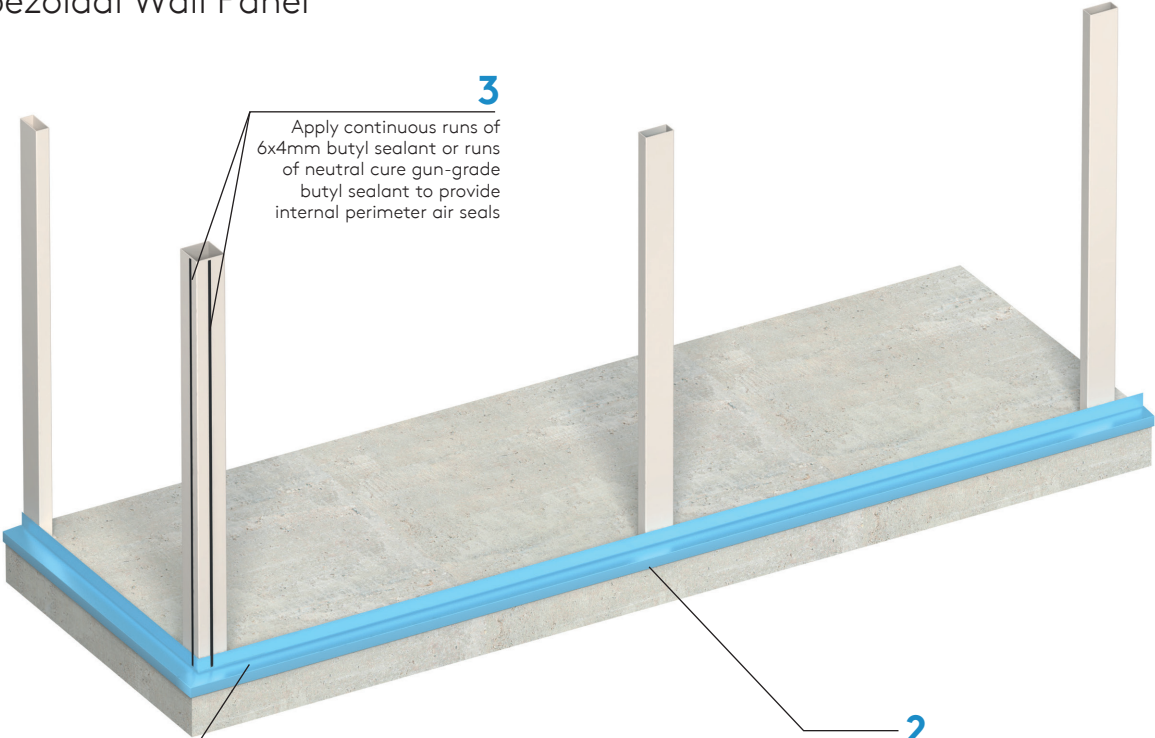
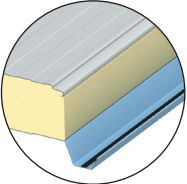

3
Apply continuous runs of 6x4mm butyl sealant or runs of neutral cure gun-grade butyl sealant to provide internal perimeter air seals

1
Fix continuous base support angle to structure. Seal with 6mm dia beads of neutral cure gun-grade butyl sealant.

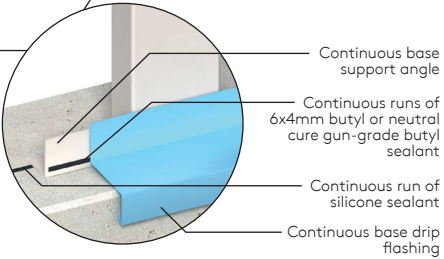

2
Line, level and fix drip flashing to continuous base support angle using low profile fixings.

Joints in the drip flashing to incorporate butt straps or sealed with two runs of neutral cure gun-grade butyl sealant

KS1000RW Trapezoidal Wall Panel

Horizontally Laid

Note: Minimum bearing face for steelwork is 100mm for panel overlap vertical joint option

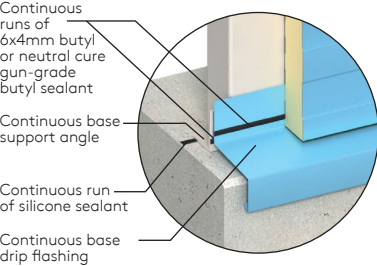

4

Apply a continuous run of 6x4mm bead of butyl sealant or neutral cure gun-grade butyl sealant to provide an air seal between back of panel and front of drip flashing

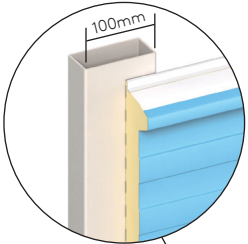

6

Install 3 No. (minimum) primary fasteners into panel valleys, at each vertical steel support location

Note: Some installations might require additional fixings depending on wind loadings/specification. Check project specific details

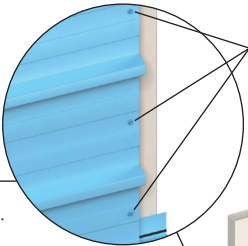

3 No. primary fasteners at each panel end

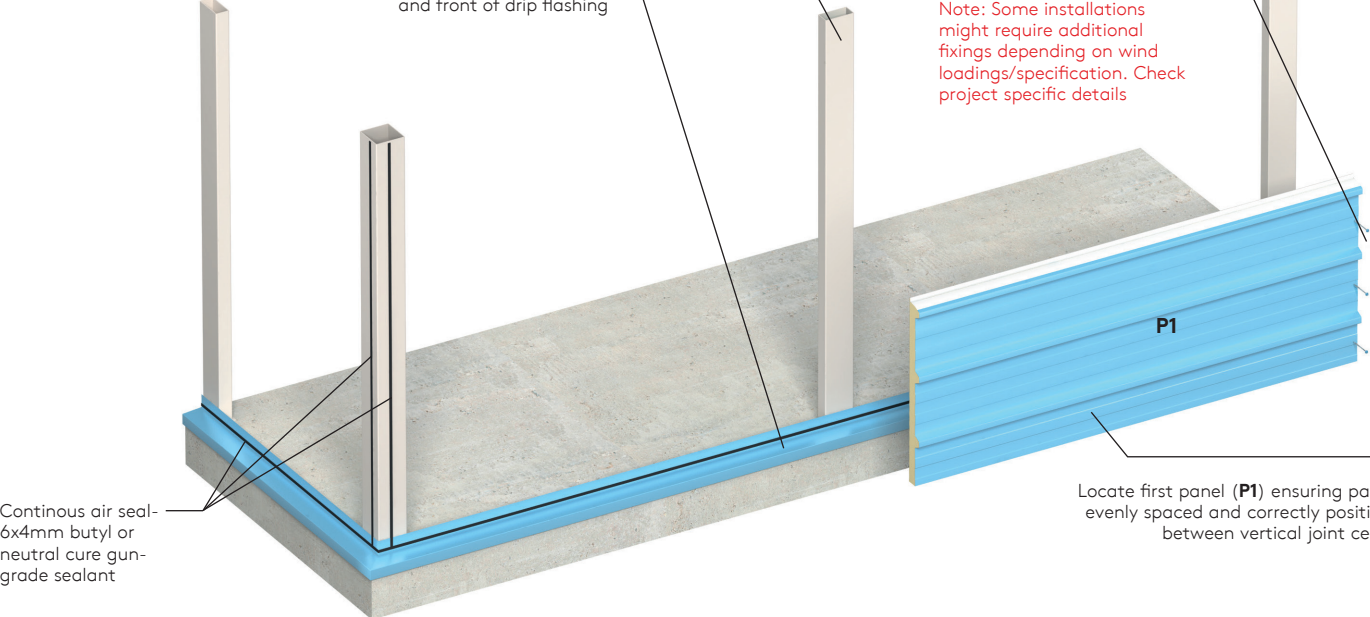

5

Locate first panel (P1) ensuring panel is evenly spaced and correctly positioned between vertical joint centres

Continous air seal- 6x4mm butyl or neutral cure gun-grade sealant

KS1000RW Trapezoidal Wall Panel

Horizontally Laid

Enlargement of Overlap

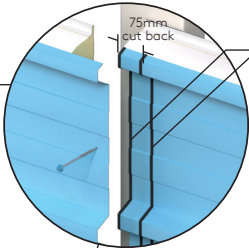
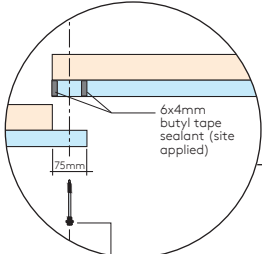
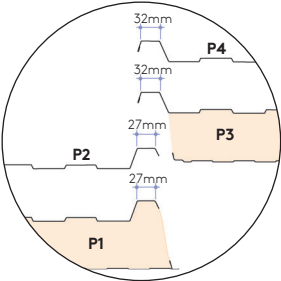

7
Apply two runs of 6x4mm butyl tape to the panel end lap.

8

Install second panel (P2) with 3 No. (minimum) primary fasteners, into the panel valley at each vertical steel support location, ensuring it is evenly spaced and correctly positioned between vertical joint centres

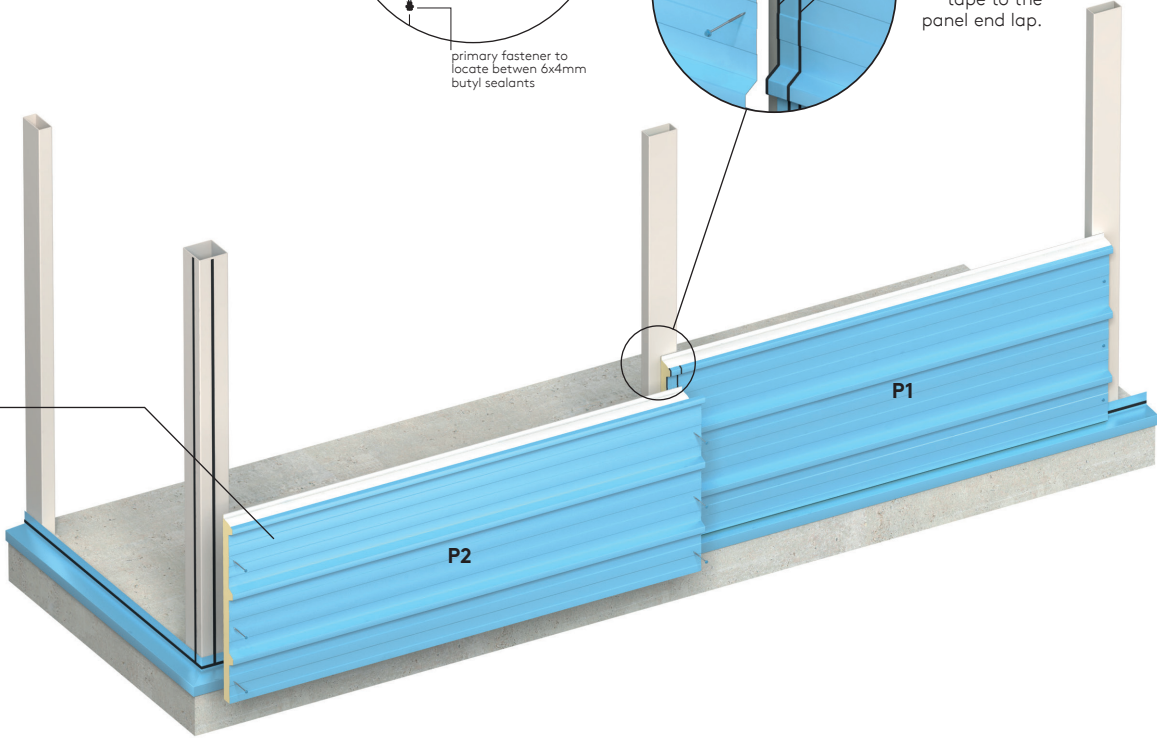

KS1000RW Trapezoidal Wall Panel

Horizontally Laid

10

Apply 6 mm dia neutral cure gun-grade butyl sealant to side of panel. Engage with previously installed perimeter air sealant on steel work to meet FAWS on proceeding panel above

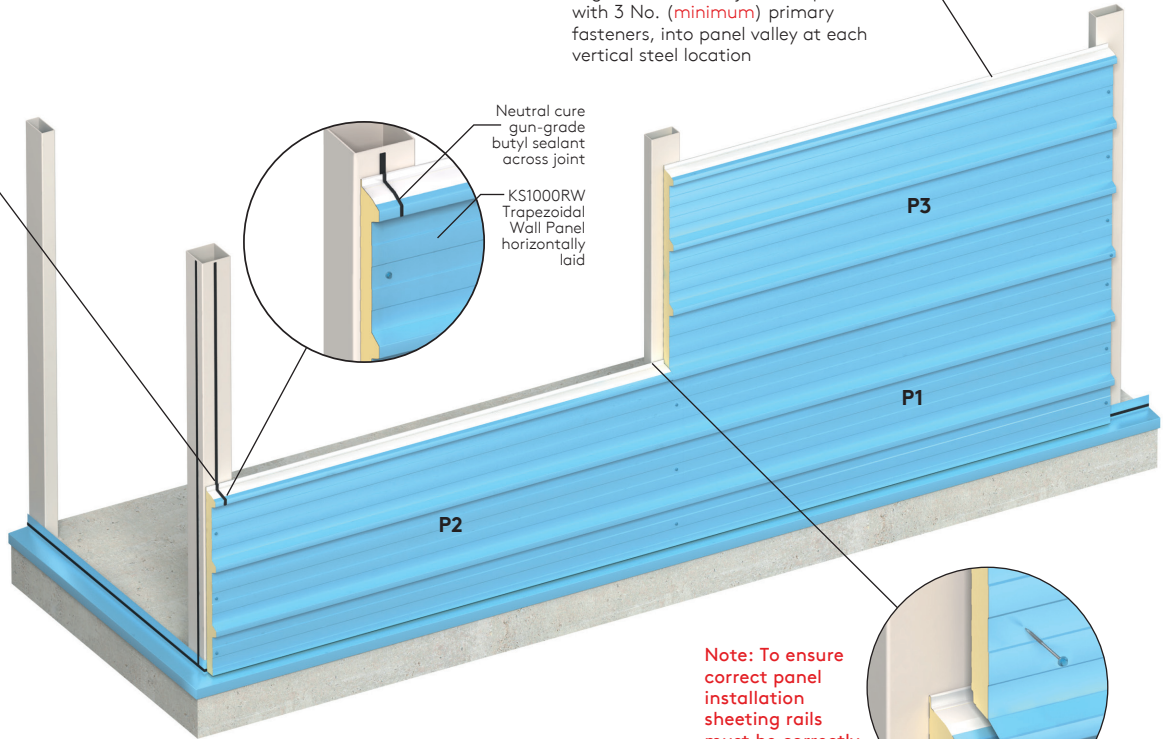

9

Install third panel (P3) ensuring sidelap correctly engages and panel aligns with vertical joint. Fix panel with 3 No. (minimum) primary fasteners, into panel valley at each vertical steel location

Neutral cure gun-grade butyl sealant across joint

KS1000RW Trapezoidal Wall Panel horizontally laid

P3

P1

P2

Note: To ensure correct panel installation sheeting rails must be correctly aligned prior to insertion of fixings

KS1000RW Trapezoidal Wall Panel

Horizontally Laid

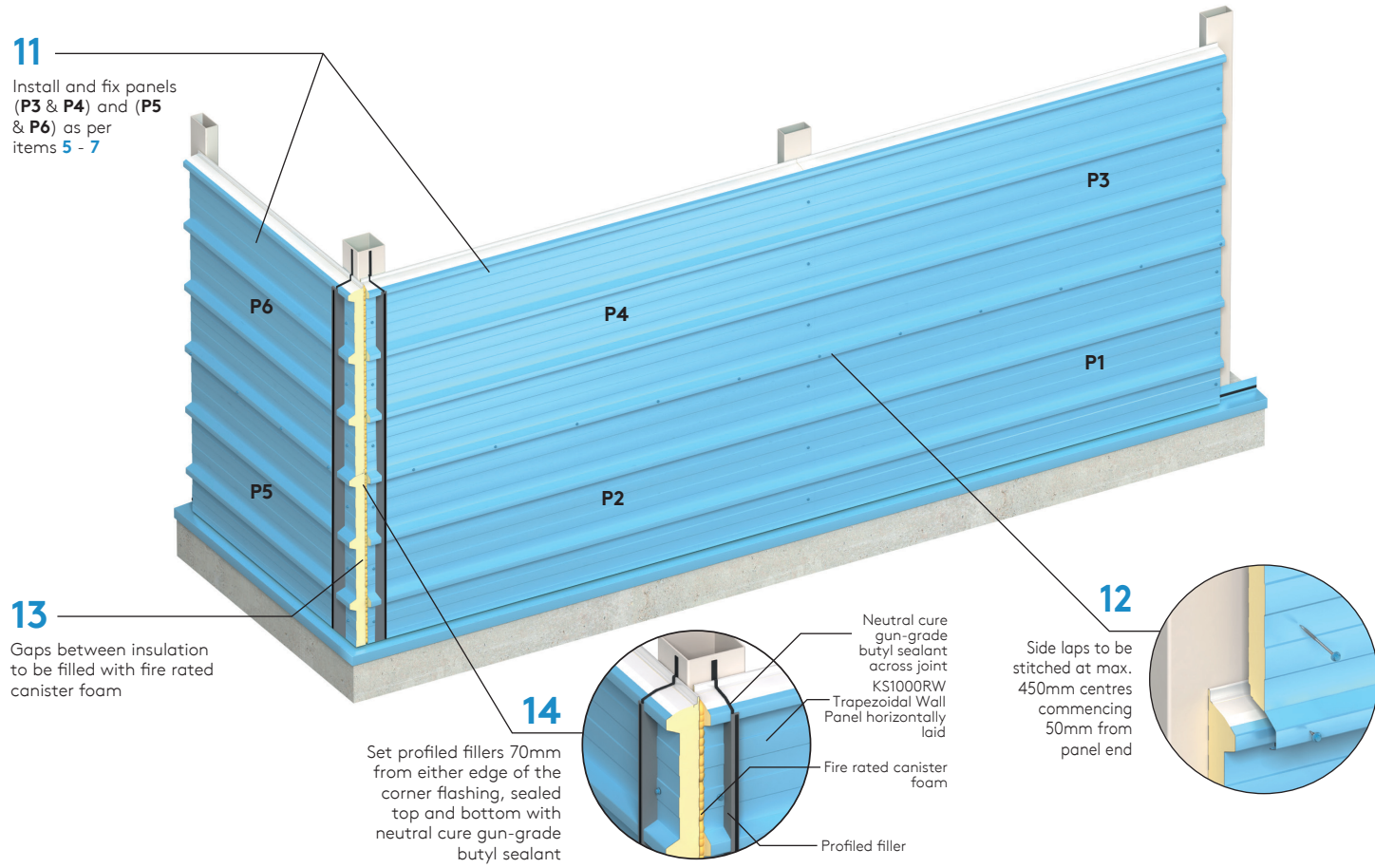

KS1000RW Trapezoidal Wall Panel

Horizontally Laid

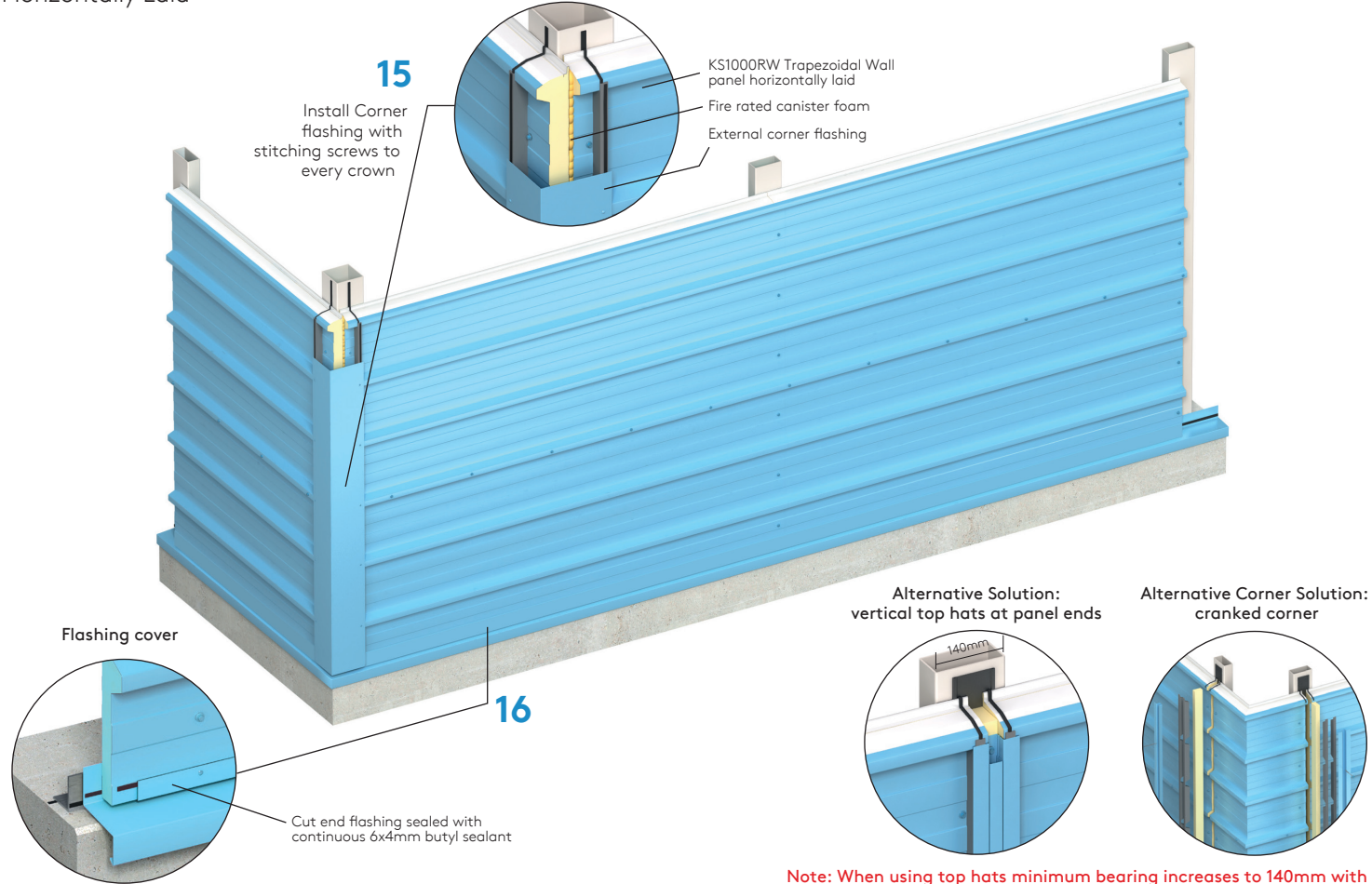

Panel Handling

Appropriate personnel protective equipment should always be worn to avoid cuts and abrasions to installers and panels.

Individual panels should always be lifted from a pack and not dragged over others.

The weight of individual panels for lifting can be determined from the information on the packing slip.

For larger panels the contractor would normally arrange to use appropriate material installation equipment to help lift the panels into position.

Protecting Film

When panels are supplied with a plastic protective film this should be removed during site installation.

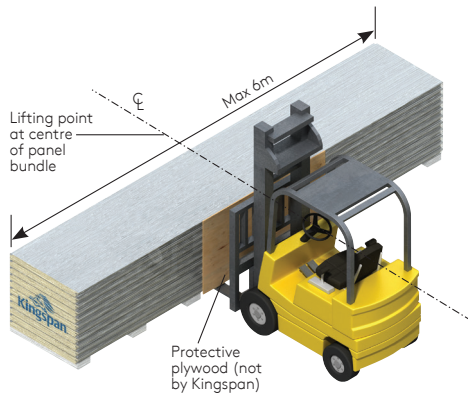

The recommended loading / unloading method for bundles less than or equal to 6m is to use a single forklift with widely spaced forks placed under the centre of the bundle as shown.

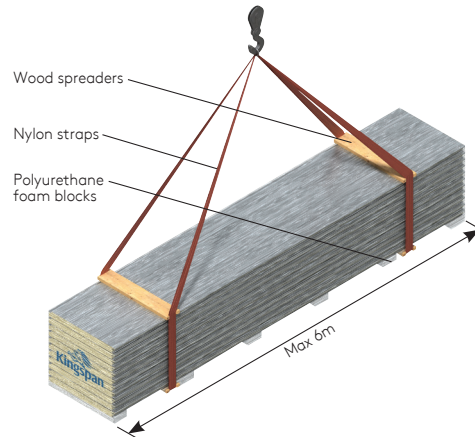

The recommended lifting method for bundles no more than or equal to 6m can be handled with a crane by using nylon straps and wood spreaders as shown.

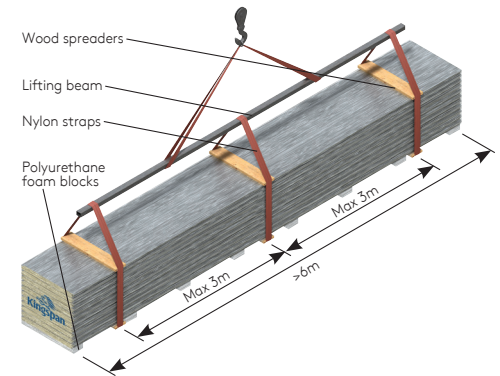

The recommended lifting method for bundles more than 6m, by crane, is by using three points of support. To prevent damage from nylon straps, use wood spreaders at top and bottom at lifting locations as shown.

Panel Handling

Correct and Incorrect Panel Handling

Caution

Individual panels should never be moved in a flat position as excessive flexing may result. Excessive flexing ruptures a panel's core, permanently distorts the facings and may lead to thermal blistering. When moving a panel, it must be turned on its edge first, then supported at each end with as many men as necessary to safely handle.

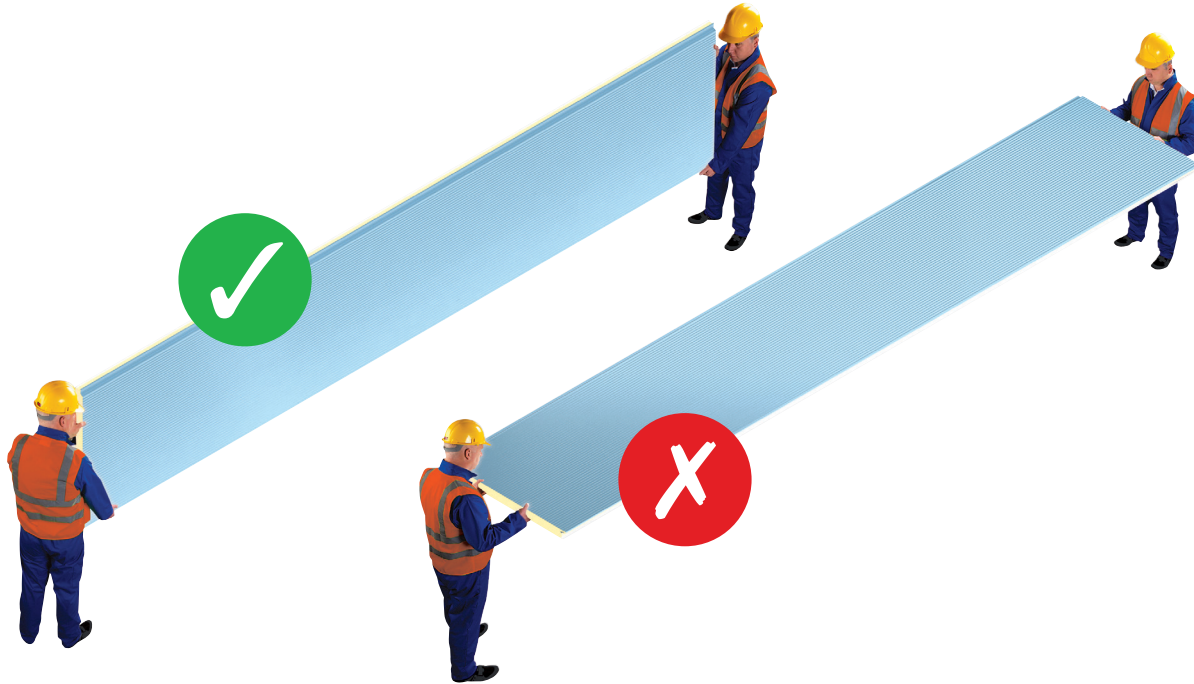

Installation guides are available for most of Kingspan insulated roof and wall panels.
For the most up to date version of this Installation guide please [click here](#) or scan the QR code below. Alternatively, please call Kingspan on:

AUS: +61 2 8889 3000
www.kingspanpanels.com.au



For the product offering in other markets please contact your local sales representative or visit www.kingspanpanels.com

Care has been taken to ensure that the contents of this publication are accurate, but Kingspan Insulated Panels and its subsidiary companies do not accept responsibility for errors or for information that is found to be misleading. Suggestions for, or description of, the end use or application of products or methods of working are for information only and Kingspan Insulated Panels and its subsidiaries accept no liability in respect thereof.

Please scan for the most up to date version of this Installation Guide.

