



WAVE BLADES

Sculptured Features

Shopdrawing service • Integrated acoustic options • Access panel options

SUPAWOOD.COM.AU

SUPAWOOD
ARCHITECTURAL LINING SYSTEMS

WAVE BLADES

Sculptured Features

When you want a special touch for a unique project.

Sculpted or contoured ceilings can be challenging for designers because of the complications of custom joinery. It can be time consuming to document, and expensive to manufacture.

Not anymore!

WAVE BLADES is the unique ceiling system that lets you quickly, easily and affordably design contoured wooden blade features. Now you can add an individual touch without going over-budget!

Benefits:

- ✓ Beauty of timber finishes and solid colours
- ✓ Can be matched to acoustic panels, slats and beams
- ✓ Acoustic options available
- ✓ 3 x standard wall options
- ✓ Shop drawing service
- ✓ 3 x standard ceiling options
- ✓ Fire Group 2 options
- ✓ Access panel options available

Easy installation

Each blade has a concealed label identifying its specific location. Blades are delivered pre-finished and packed by area for easy installation.

WAVE BLADES have a simple fixing system suitable for use by any approved partition contractor which minimises installation time.



Melbourne Airport T2 Luxury Retail, Melbourne VIC

► **Builder:**
Lend Lease Building

► **Architect:**
NH Architecture



Standard options make it easy

Choose from one of our standard WAVE BLADE styles or design your own

Just nominate a maximum and minimum depth and what centres you would like.

Note: Blades are standard at 18mm thick.

	Recommended combinations		Recommended minimum centre spacings to achieve	
	Max Depth	Min Depth	Fire Group 3	Fire Group 2
Depth 1	290	140	150	250
Depth 2	390	190	200	300
Depth 3	590	290	300	400

WAVE BLADE

FIXING

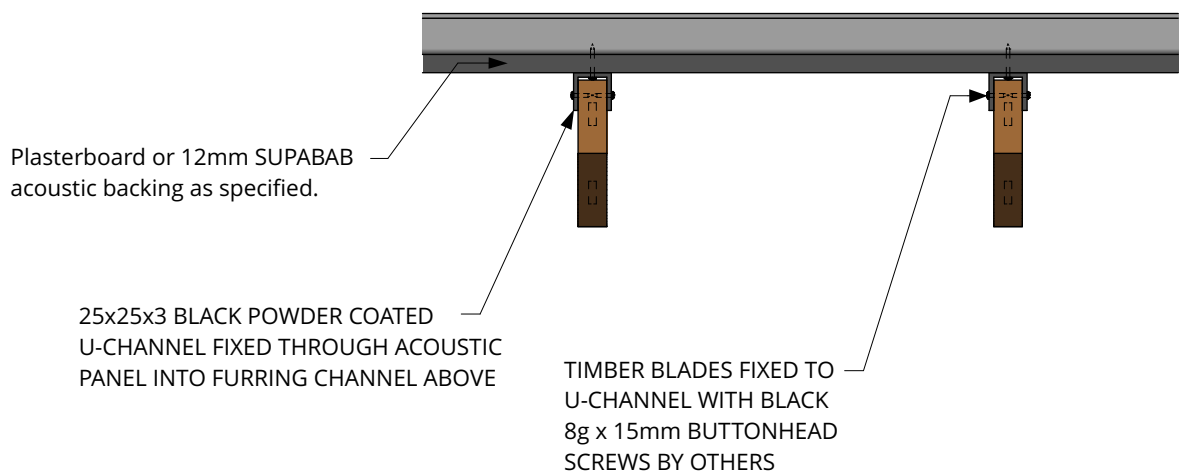

RAIN DROP

CEILING

View:
Looking from below

Note:
Blades can be extended to fill
a square or rectangular space.

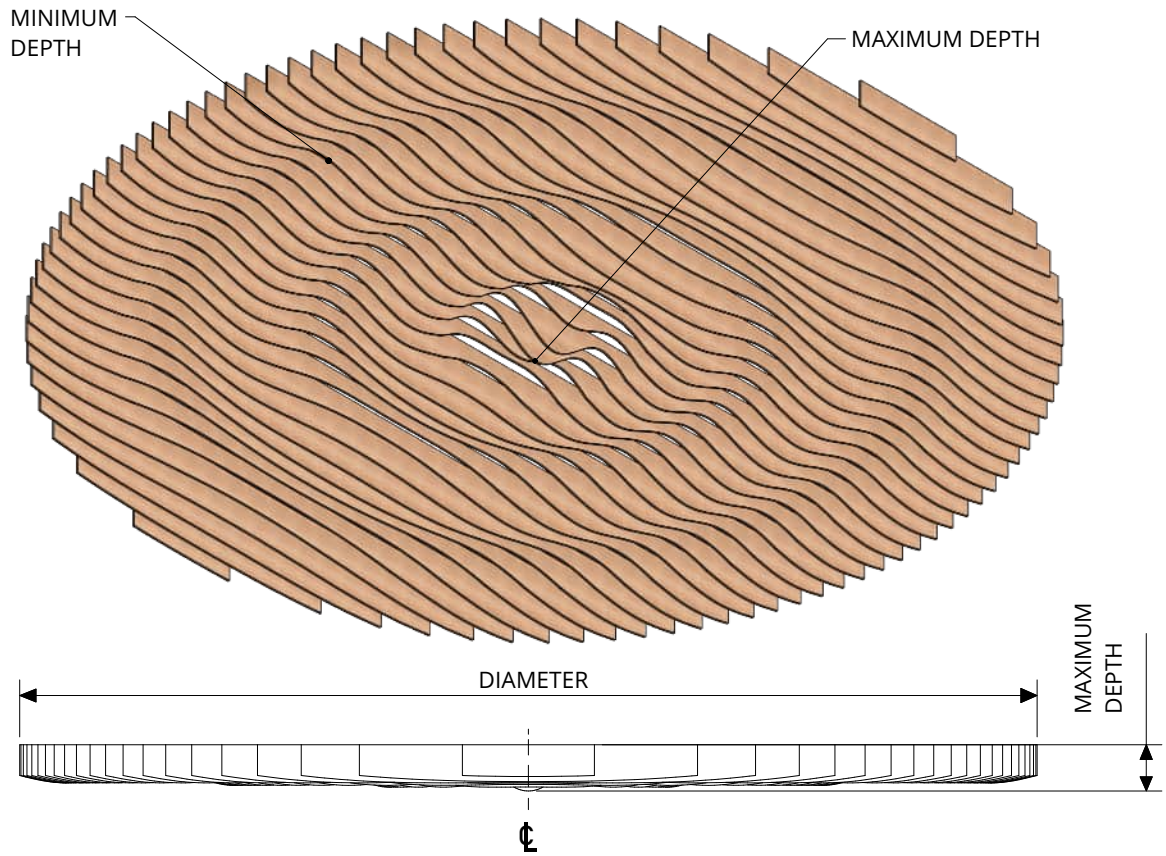

RIPPLE

WALL

Note:
This option can also be used as a screen.

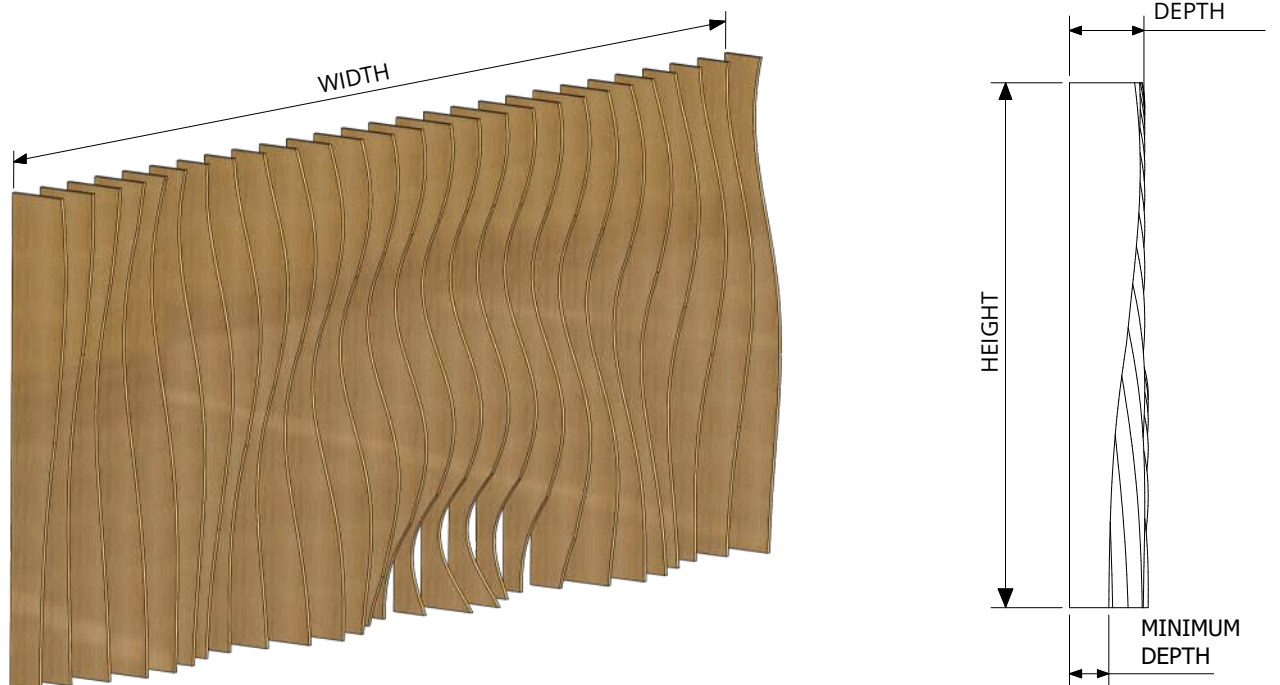

WAVE

CEILING

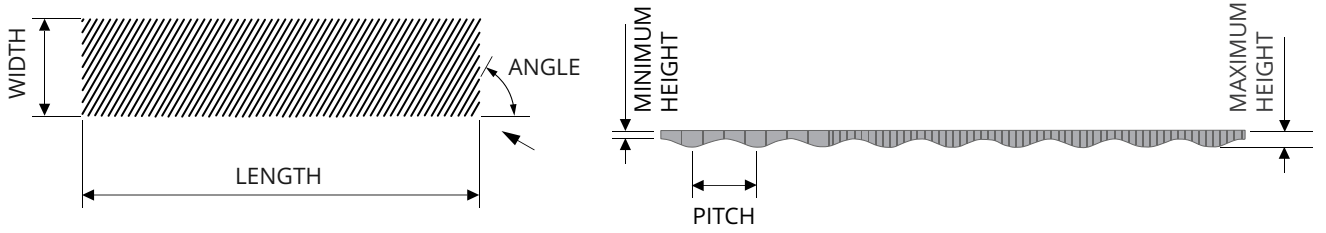
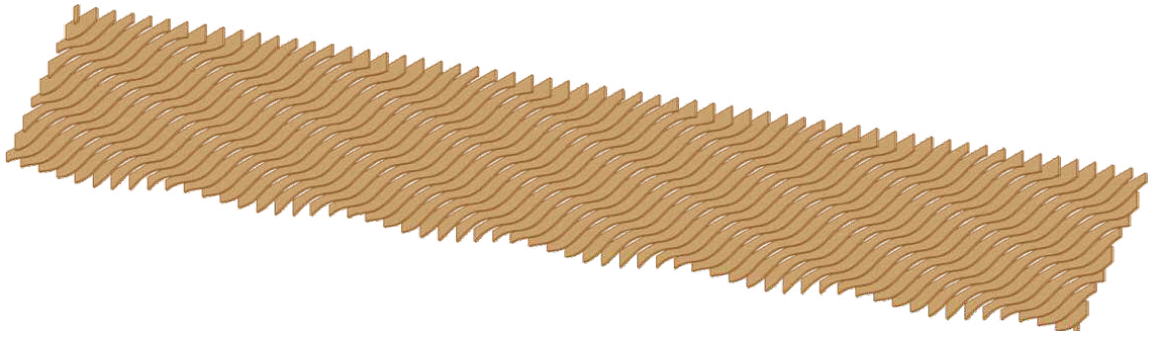

ZIGZAG

CEILING

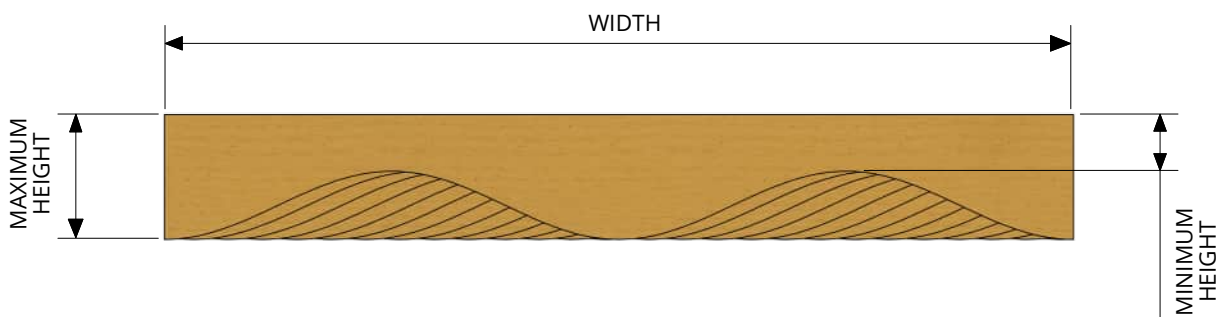
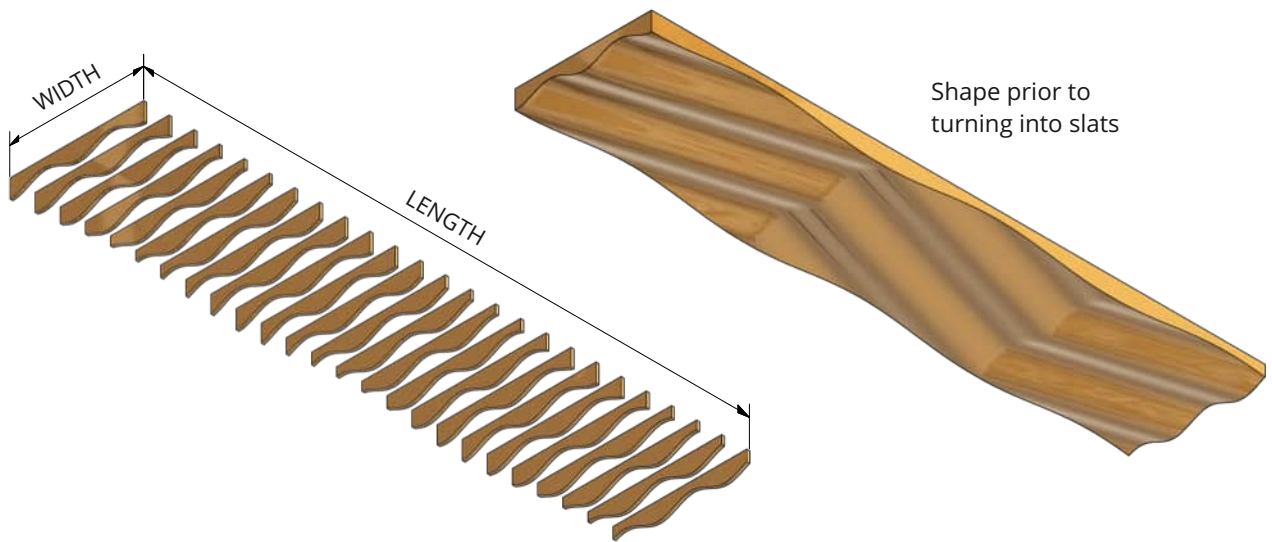

Finishes and colours

All of SUPAWOOD's standard finishes are available across the full range of panels, slats, beams and blades.

Colours shown are a guide only and will vary from blade to blade.

SUPA VENEER

(NTV) Natural Timber Veneer

Other species also available.
Only Fire Group 3 available.



Hoop Pine CC

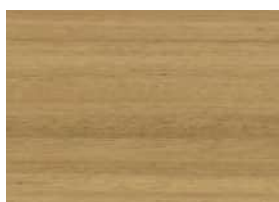

Tasmanian Oak 1/4



Blackbutt 1/4



American Oak CC



Spotted Gum 1/4



American Walnut CC



Midnight Black

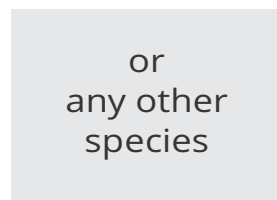

or
any other
species

Your Choice

SUPA TEXTURE

(ST) Tactile Woodgrains & Finishes

Group 2 Fire Retardant available.



Limewash



Vic Ash

Tactile and highly durable we're so confident in SUPATEXTURE we offer a unique 30-year no hassle warranty.



Tasmanian Oak



Blackbutt



Spotted Gum

SUPAFINISH

(SF) Veneer & Coloured Laminates

Group 2 Fire Retardant available.



Vic Ash SF



Hoop Pine Limed SF



Fusion Maple SF



Hoop Pine Classic SF



Euro Beech SF



Tasmanian Oak SF



Blackbutt SF



Spotted Gum SF

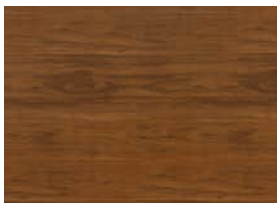

Virgin Walnut SF

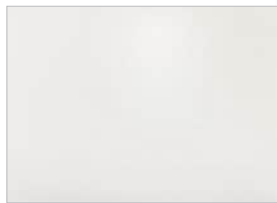

White SF



Black SF

SUPACOLOUR

(SCR) Painted Finishes

Highly durable satin, high gloss and metallic finishes matched to any colour.

Group 2 Fire Retardant available.



**MATCH TO ANY
COLOUR REFERENCE**

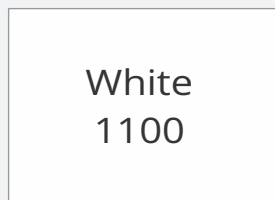

White
1100

NEED SOMETHING SPECIAL?

Can't find the right shade here? Get in touch with the team to discuss what custom finishes are possible and to request samples.

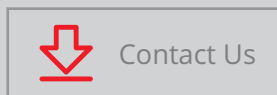

Colours shown in these swatches are a guide only and actual finishes will vary from panel to panel. Custom finishes are also available. Please contact our customer service team on 1800 002 123 for further information.

WAVE BLADES Configurators

Create your own design

effortlessly with our dedicated WAVE BLADES configurators. Select from three specific options (Ripple, Wave or Bump) or choose "Random" to create a completely unique design.

Visit our WAVE BLADES
Configurator portal >

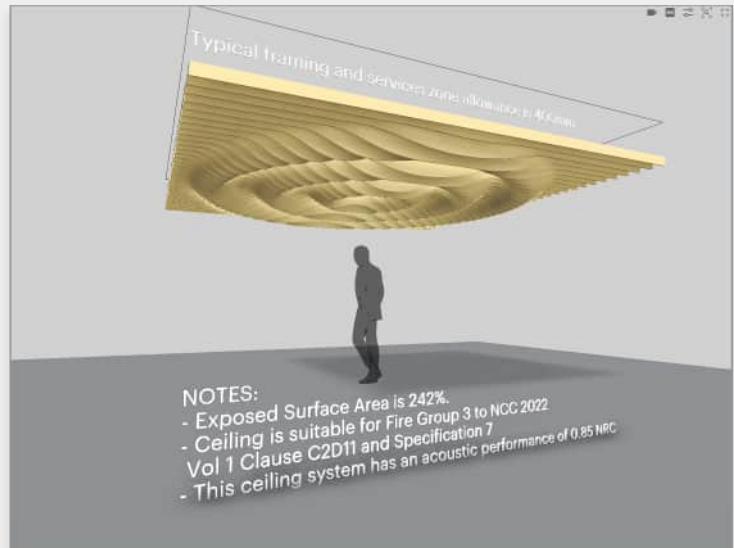

DOWNLOAD WAVE BLADES SPEC WORDING

It's not easy to make your project stand out and satisfy performance, compliance and budget needs. We customise our systems to your requirements.

DISCUSS YOUR PROJECT

SUPAWOOD
ARCHITECTURAL LINING SYSTEMS

SUPAWOOD HEAD OFFICE
Australasian Support & Manufacturing
Aus: +61 1800 002 123
NZ: +64 (0) 9887 3234
info@supawood.com.au

SUPAWOOD UK
UK & EU Support & Manufacturing
+44 (0) 3307 00 00 30
sales@supawood.com.uk

Version 3.0

SUPAWOOD.COM.AU

Make Your Mark