

MetalWorks R-H200 R-H215 Mesh Hook On Installation Guide

Armstrong
CEILING SOLUTIONS



METALWORKS

MetalWorks R-H200 R-H215 Mesh Hook On Installation and Maintenance

General

Product Description

METALWORKS Mesh includes a collection of Expanded galvanised steel, powdercoated, Hook On ceiling panels and suspension systems marketed by Armstrong World Industries.

Installation instructions

Armstrong METALWORKS Mesh Ceilings are **INTERIOR FINISHES ONLY** and conditions during the installation should reflect this. Armstrong recommends during installation that relative humidity should not exceed 99%, within a temperature range of 0 to 49 degrees Celsius and with the absence of any "standing water". Conditions following completion should be maintained as such.

Because of the risk of soiling, the installation of ceiling panels should only take place after the completion of any work generating large amounts of dust. The wearing of clean gloves is recommended for installation work. The ceiling installer is responsible for the satisfactory installation of the ceiling and adherence to industry best practice and in accordance with AS/NZS2785:2020.

Ceiling panels should only be stored in a dust-free and dry area. It is important to ensure that the panels are not subjected to any mechanical influences, such as damage caused by the underlying surface. Ceiling panels delivered on pallets should be stored in their original packaging until they are installed. Where this is not possible, care should be taken to ensure that cartons are stored with the designated side facing upwards. The installation company is responsible for the careful storage of panels.

The ceiling system is made up of Armstrong METALWORKS Hook On In panels which are supported by the Armstrong Suspension System (U-Profile Channel, J-Bar or H-Bar and hangers) and Wall Angle which runs around the perimeter of the space.

The integrity of the entire suspended ceiling depends on the hangers – commonly 5mm gal rod is used, with some contractors using 2.5mm wire and M6 Threaded Rod (Both types meet Australian / New Zealand standard 2785-2020) which are used to support the U-Profile. Bracing is to be applied where required to ensure the Suspension System remains square.

***Note: Specially designed MetalWorks Ceilings for EXTERIOR applications are available upon request. Contact your Armstrong Ceiling Solutions Representative for details and conditions.**

Cutting Options

Cutting procedures for each type of METALWORKS Mesh are as follows:

CAUTION: Cut edges of metal parts can be extremely sharp! Handle metal carefully to avoid injury. Always wear safety glasses and gloves when working with metal.

NOTE: During cutting – To prevent scratching, apply protective material to the face of the panel.

Cold Cut Saw – For all Mesh options: Expanded, Welded and Woven

Cold cut saw (including jig saw or non friction blade apparatus) has the advantage of not transferring heat to the Mesh panel, preventing panel distortion and burning of paint.

Procedure: Mark panels and cut where required.

Penetrations Cutouts

Procedure: Penetrations are created using the equipment and procedure described above depending on Mesh type. Exercise caution during this procedure as the hand will be in close proximity to the cut edge of the panel

Backloading

Unless approved, Armstrong METALWORKS Mesh Ceilings are designed to support only their own weight. All mechanical services must be independently supported. Contact Armstrong for more information if required.

Maintenance

Ceiling panels may be cleaned at any time. However, any maintenance work on suspended ceilings should only be carried out after the technical functions of the ceiling installation have been carefully checked. In cases of doubt, the relevant Armstrong sales office should be contacted.

In the case of damage to individual ceiling panels, these can be exchanged within the systems. In such instances, especially after extended periods of use, colour variations may occur when individual panels are replaced.

Armstrong – paint coatings

Armstrong ceiling panels are finished with a polyester powdercoat.

Cleaning of Armstrong METALWORKS metal ceilings.

The frequency of cleaning will depend upon the function and usage of each area and the efficiency of the air conditioning/heating system. This period can only be determined after handover and occupancy. Although the ceiling materials are provided with durable paint finish, abrasive or strong chemical detergent should not be used. A mild detergent diluted in warm water applied with a soft cloth, rinsed and finally wiped off with a chamois leather will maintain the ceiling in good condition. Oily or stubborn stains if not removed by washing can be wiped off with white spirit but care is necessary to avoid affecting the gloss level of the paint finishes.

Installation

Refer to Page 3 for specific instructions for installing the R-H200 Hook On system and page 11 for the R-H215 Hook On System.

MetalWorks MESH R-H200 Hook

Installation Guide

Product Description

MetalWorks R-H200 Hook-on panel system is a downward accessible, metal ceiling available in a range of sizes. Panels can be removed and reinstalled from below to gain access to the plenum. The ceiling system is made up of Armstrong METALWORKS R-H200 Hook On In panels which are supported by the Armstrong Ceilings Suspension System, comprising of: U-Profile Channels, J-Bar (Hook On Rails), Suspension Clips & hangers and Wall Angles located around the perimeter of the space.

The integrity of the entire suspended ceiling depends on the hangers – commonly 5mm gal rod is used, with some contractors using 2.5mm wire and M6 Threaded Rod (Both types meet Australian / New Zealand standard 2785-2020) which are used to support the main bars. Bracing is to be applied where required to ensure the U-Profile Suspension System remains square. The panels are supported on two sides only (can be either the long sides or the short ends – check drawings and specification).

One side will have a short hook detail that allows the panel to engage on the J-Bar suspension element and the opposite side has a long hook that will rest on top of the adjacent panel short hook. The short hook side may be easily disengaged for panel removal and plenum access. The non-supporting sides have vertical returns.

1. Before You Start

- All material delivered to site should be checked for damage, unopened and original packages.
- At this stage if you are unsure of the suitability of material for this project, ask questions, as it is very expensive to remove materials that have been installed.
- All materials to be kept dry and protected from the elements.

2. Plenum Space

- The installation of Armstrong MetalWorks R-H200 Hook On panels requires no more space in the plenum than that which is required to hang the suspension system. Panels never need to travel into the plenum space during installation or removal.
- The total height of the ceiling assembly is approximately 100mm measured from the face of the panel to the top of the U-Profile Channel. Additional space is required for the attachment of Suspension Clip and 5mm Rod.

3. Determine Ceiling Orientation

- It is important at this stage to determine the direction the ceiling grid and Baffles to be installed.
- The drawing supplied by the builder will show the panel direction required (rectangular panels).
- U-Profile Channels are typically oriented perpendicular to the roof purlins or joists.

For Seismic Design support please contact your local Armstrong Ceilings office

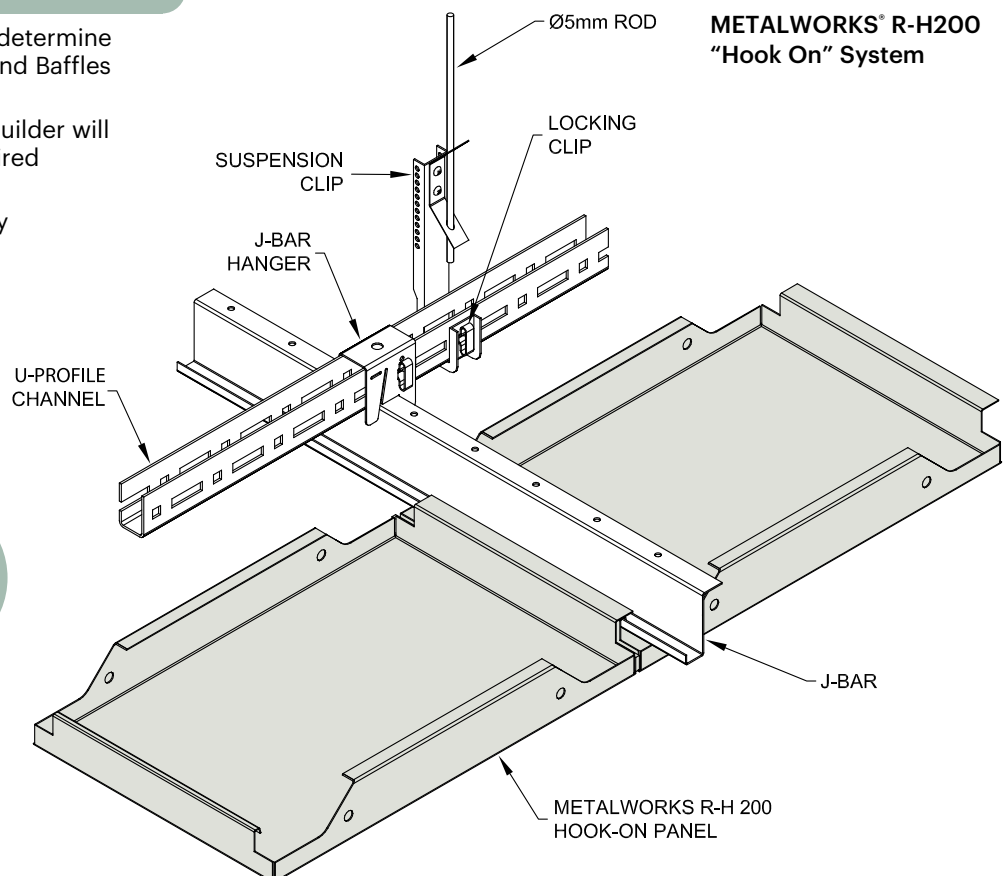

MetalWorks MESH R-H200 Hook

4. Installation Of Wall Angle

- Wall angle type is to be determined and installed at the ceiling height as described on the construction drawing.
- Mark the desired height of the wall molding. Use a chalk line or laser to mark all walls at the same height.
- Wall angles to be fixed up to a maximum of 600mm centers to the building structure.
- The type of fixings to be used will be determined by the type of building base material used.
- Ensure all butt joints are tight and miters in corners are also neat and tight.

5. Installation Of Hangers and U-Profile

- The 5mm Gal rod shall to be cut to pre-determined lengths, and a hook bent to 30° on one end (must be a sharp bend, so the suspension bracket will fit into the bend without the rod straightening).

Where specified, the U-Profile Channel can be suspended on 6mm galvanised threaded rod. See Fig. 2 for details (Suspension Clip for Threaded Rod is Item UNITRCB).

- Fit the Suspension Clip to the rod at this stage and fasten with Locking Clip (item UNI200).
- The Locking Clip is correctly fitted with the longer tongue face up (see Fig 1). The Locking clip can be removed by pressing down on the upper tongue.

Fig. 1: Locking Clip Installation

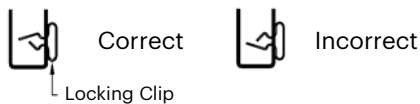

- If using 2.5mm Suspension Wire, bend the wire around the U-Profile Channel and wrap it around itself 3 times.
- Ensure all suspension rods are vertical.
- When installing the ceiling under a metal roof structure, ensure the U-Profile Channels (Item UNI111B) run at perpendicular to the purlins / trusses.
- Install U-Profile Channels at 1200mm (maximum) centres with Suspension Hangers (5mm Rod and Clip) at 1200mm (maximum) centres along the length of each U-Profile Channel. Ensure Locking Clips are installed to secure the Suspension Clip to the U-Profile Channel. See Fig. 2 for details and specific components: 5mm Rod, Suspension Clip (item UNI203B) and Locking Clip (item UNI200)

Fig. 2: U-Profile Channel and Suspension Components

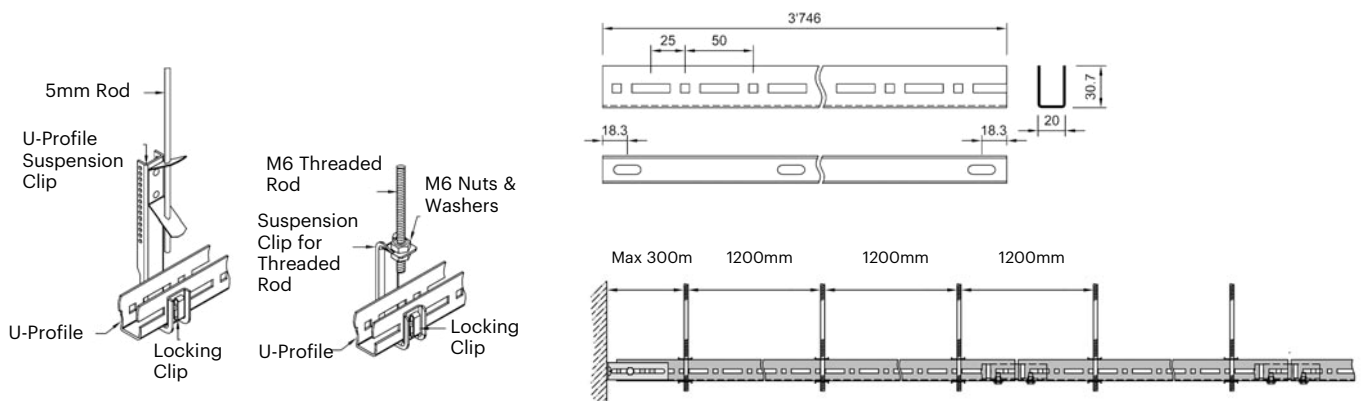

- The U-Profile Channels adjacent to the perimeter must have three suspension points, with the other U-Profile Channels in between requiring a minimum of two suspension points.
- U-Profile Channels are to be secured to the perimeter with the U-Profile Wall Anchor Bracket (Item UNI202) See Fig. 3 for details

Fig 3: U-Profile Detail at Perimeter

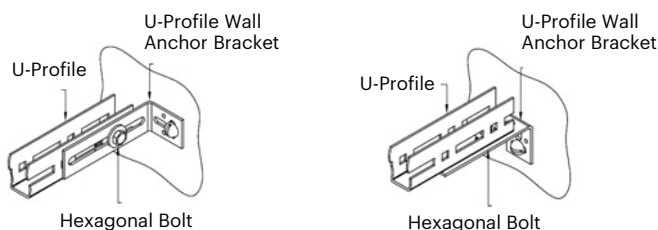

MetalWorks MESH R-H200 Hook

5. Installation Of Hangers and U-Profile (Continued)

- U-Profile Channels are to be joined end to end with a U-Profile Channel Connector (Item UNI103B). See Fig. 4
- To ensure the U-Profile Channels are kept precisely on module, tolerances in the U-Profile Channel can be absorbed in the joint with the connector.

Fig 4: U-Profile Channel and Connector

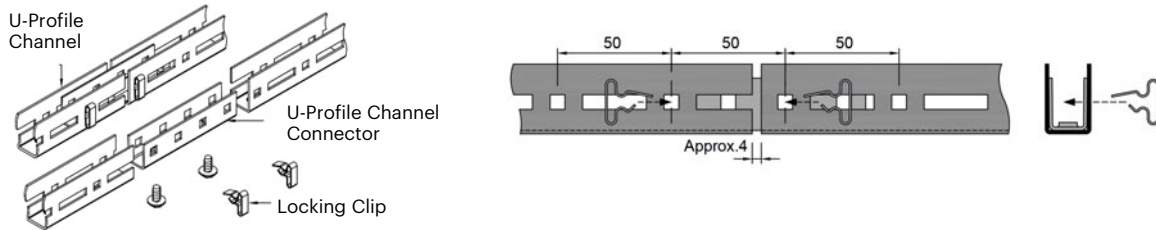

- The 1st U-Profile Channel must be no more than 300mm from the perimeter, with the first suspension point being no greater than 300mm from the end of the U-Profile Channel.
- The U-Profile Channels are to be installed parallel, in a manner that the punchings along the length, align from one U-Profile Channel to the next. Note: the U-Profile Channels are directional and punched on both sides at 50mm OC, and 25mm offset. See Fig. 2 for details.
- It is recommended that main bar joins should be staggered to increase the strength of the system.

6. Components

Item Number	Description
UNI111B	U-Profile Channel (3750mm)
UNI103B	U-Profile Channel Connector
IND300026	J-Bar for R-H200 (4000mm)
UNI101	J-Bar Hanger
BPM300343	J-Bar Connector
UNI203B	Suspension Clip for 5mm Rod
UNITRCB	Suspension Clip for M6 Threaded Rod
ROD 5mm	5mm Suspension Rod
UNI200	Locking Clip
IND330056	J-Bar Security Clip
AL008RCPSW	Std "L" Wall Angle
AL009RCPSW	Shadowline Wall Angle
UNI202	U-Profile Wall Anchor Bracket

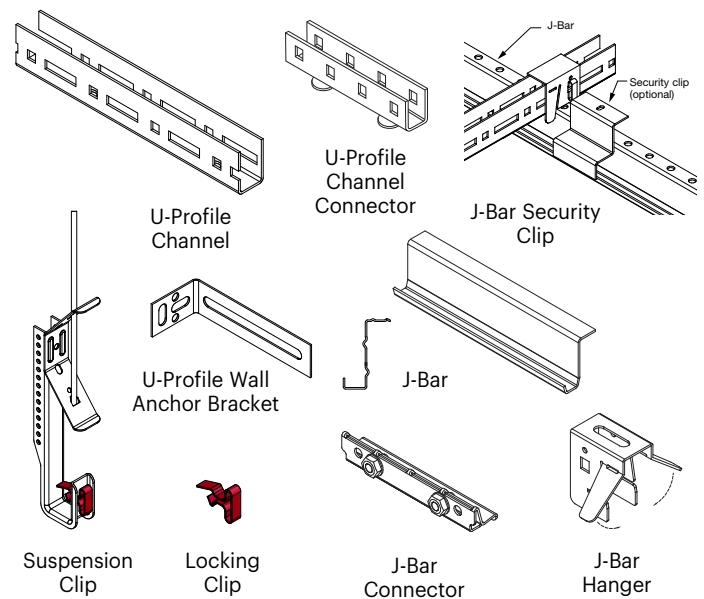

7. J-Bar Installation

- J-Bar "Hook-On" Rails (Item IND300026) are installed perpendicular to the U-Profile Rails and located according to panel size: Typically, if supporting panels on short ends, such as for 1200 long panels, locate H-Bars at 1200mm centres; 1500mm long panels at 1500mm centres and so on. Note - J-Bar Hangers are directional.
- Each J-Bar is suspended from the U-Profile Channel using "J-Bar Hangers" (item UNI101).
- J-Bar Hangers install over the U-Profile Channel and are secured with Locking Clips (item UNI200) - See Fig 5: for details.
- The top leg of the J-Bar inserts into the slot in the J-Bar Hanger and secured by folding down both wings of the J-Bar Hanger.
- J-Bars are joined end to end with J-Bar Connectors (item BPM300343). Slide the J-Bar Connector over the sections to be joined and tighten bolts. - See Fig 7: for details.
- J-Bars are to be secured to the perimeter with the U-Profile Wall Anchor Bracket (Item UNI202) See Fig. 7 for details.

MetalWorks R-H200 Hook On

Fig 5:

J-Bar Hangers install over the U-Profile Channel and are secured with Locking Clips (item UNI200).

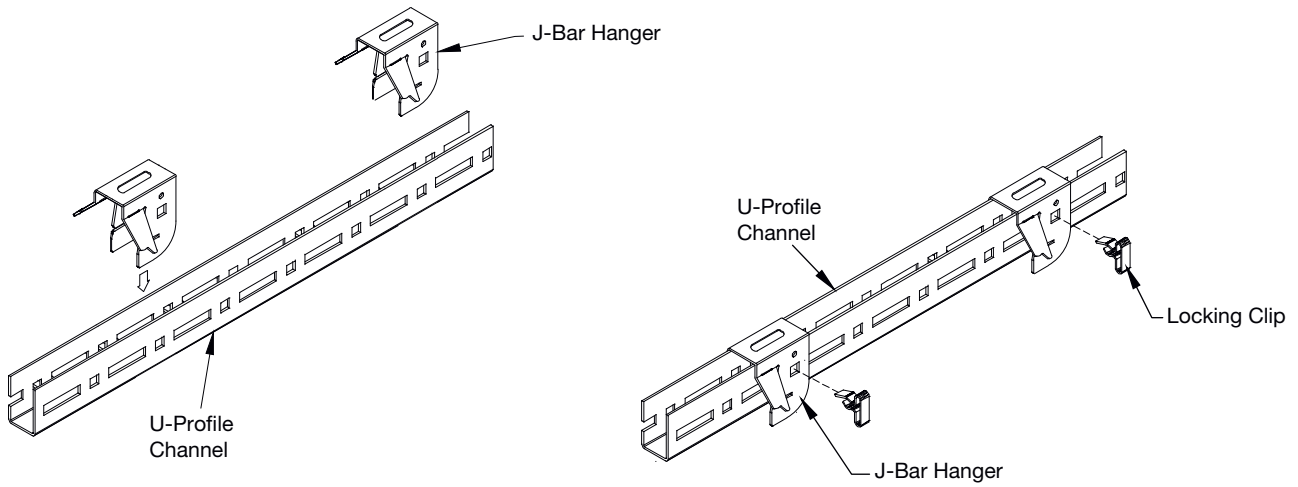
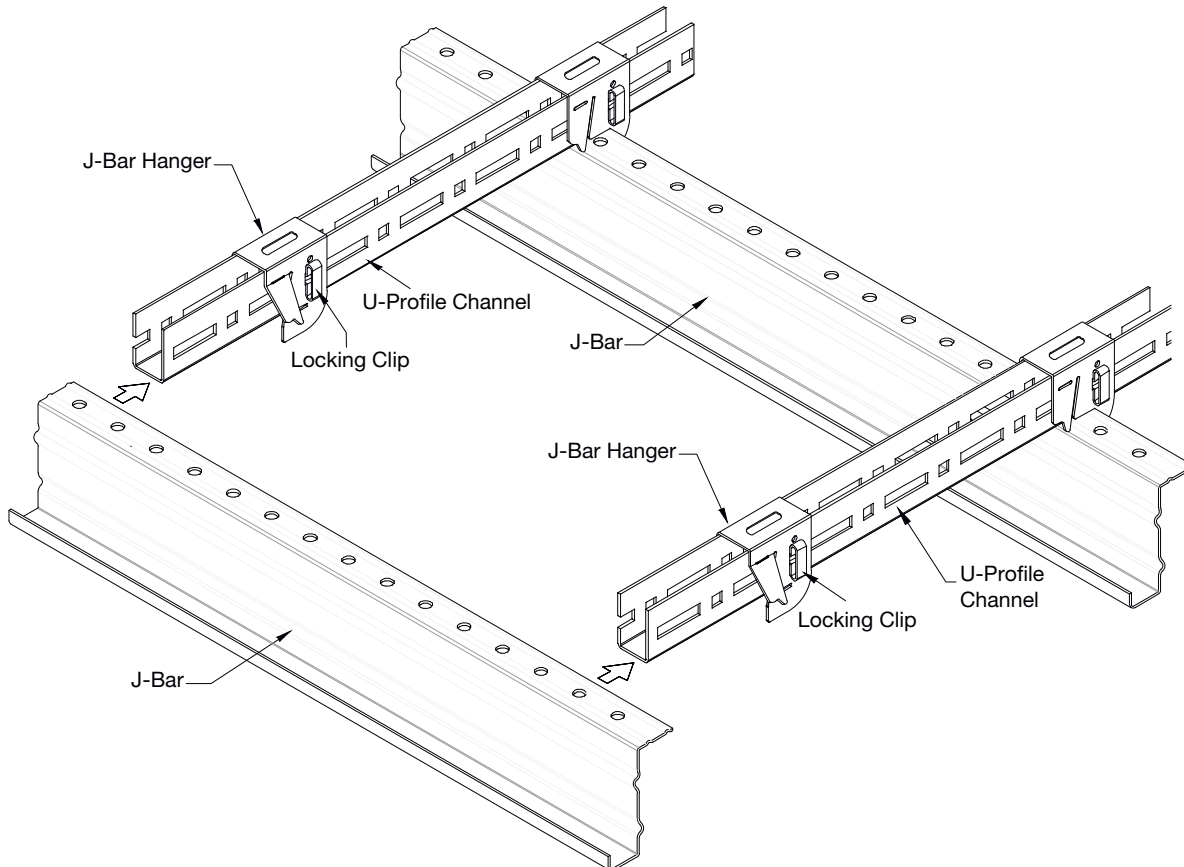

Fig 6:

J-Bars are fixed into position with J-bar Hangers and Locking Clips.



MetalWorks R-H200 Hook On

Fig 7:

J-Bars are joined end to end with J-Bar Connectors (item BPM300343). Use the J-Bar Connector to join sections of J-Bar. Slide the J-Bar Connector over the sections to be joined and tighten bolt.

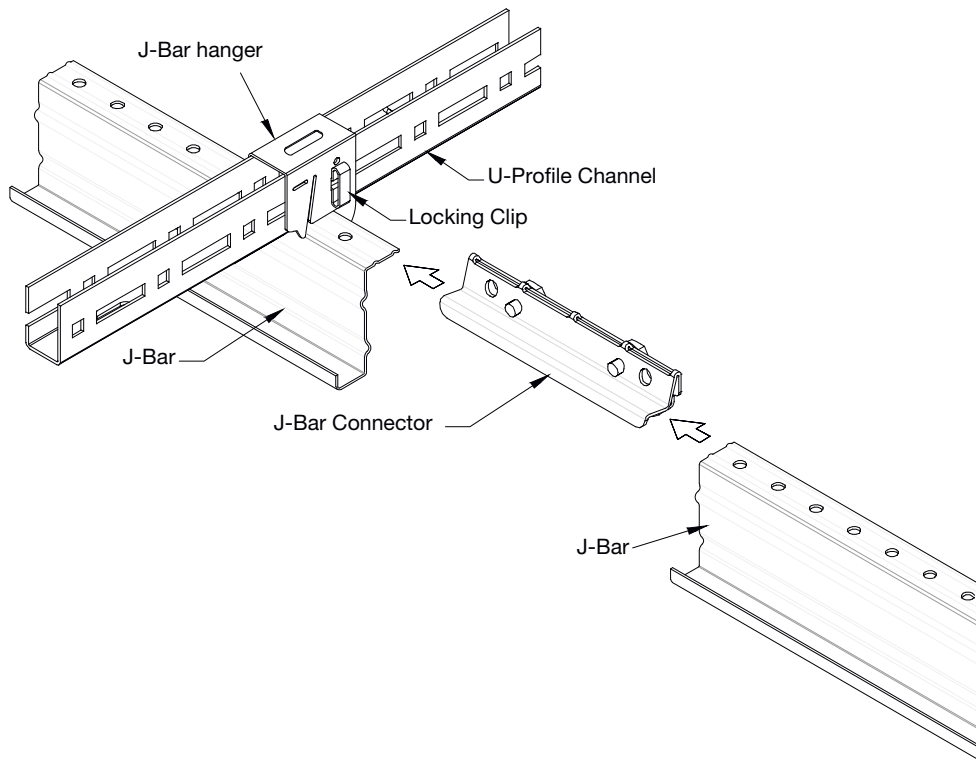
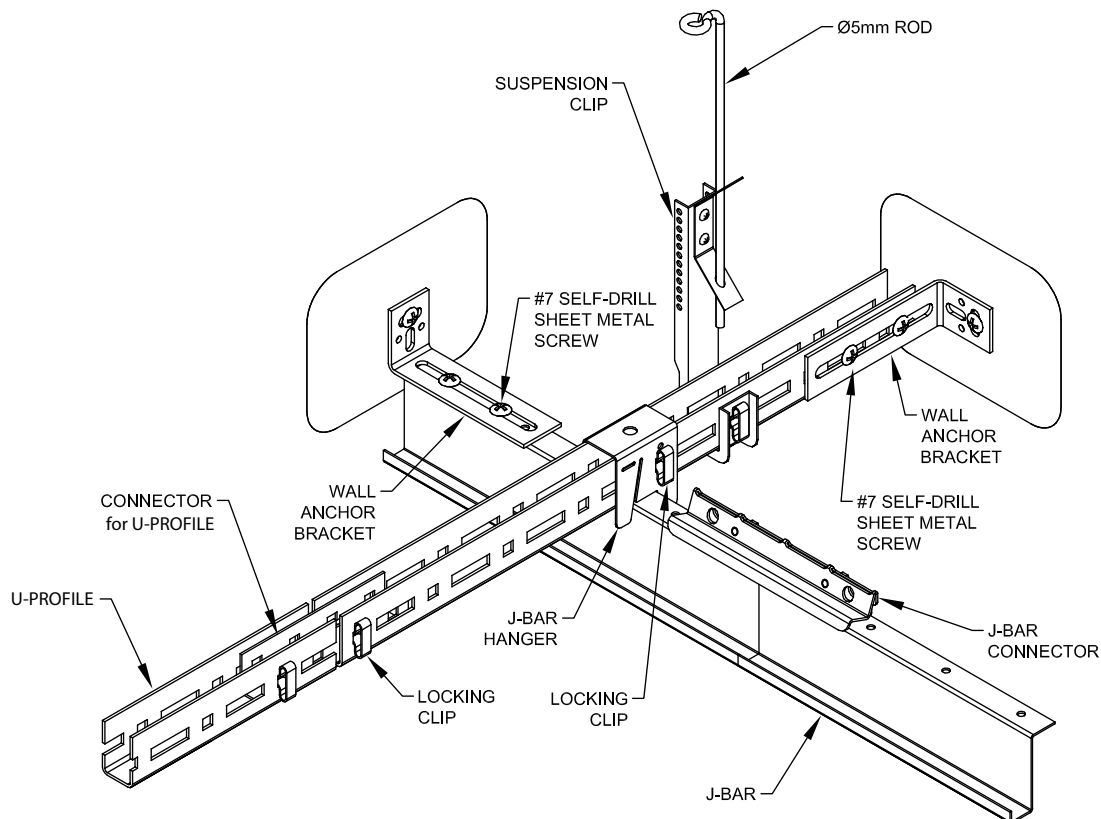

Fig 8:

J-Bars are to be secured to the perimeter with the U-Profile Wall Anchor Bracket (Item UNI202)



MetalWorks R-H200 Hook On

8. R-H200 Panel Installation

Square the Grid, Bracing Requirements and Levelling

- Measure across the diagonals of the opening. The measurements will be the same if the grid is square.
- Depending on the size of the ceiling and design details there could be a requirement for bracing to hold the grid square and to stop grid movement during installation.
- The amount of bracing required is to be determined onsite by the installer.
- The ceiling system can be levelled by adjusting the suspension clip up and down with the use of a laser.
- The metal ceiling panels are installed as specified on the ceiling layout drawing. Panel installation is directional. The use of a laser or string line is recommended to establish straight panel alignment. A row of properly aligned panels may be secured to the J-Bars to maintain full ceiling alignment.

Fig 9:

An optional security clip may be fastened to the J-Bar to prevent panel removal if required. The system is non-accessible if security clips are installed.

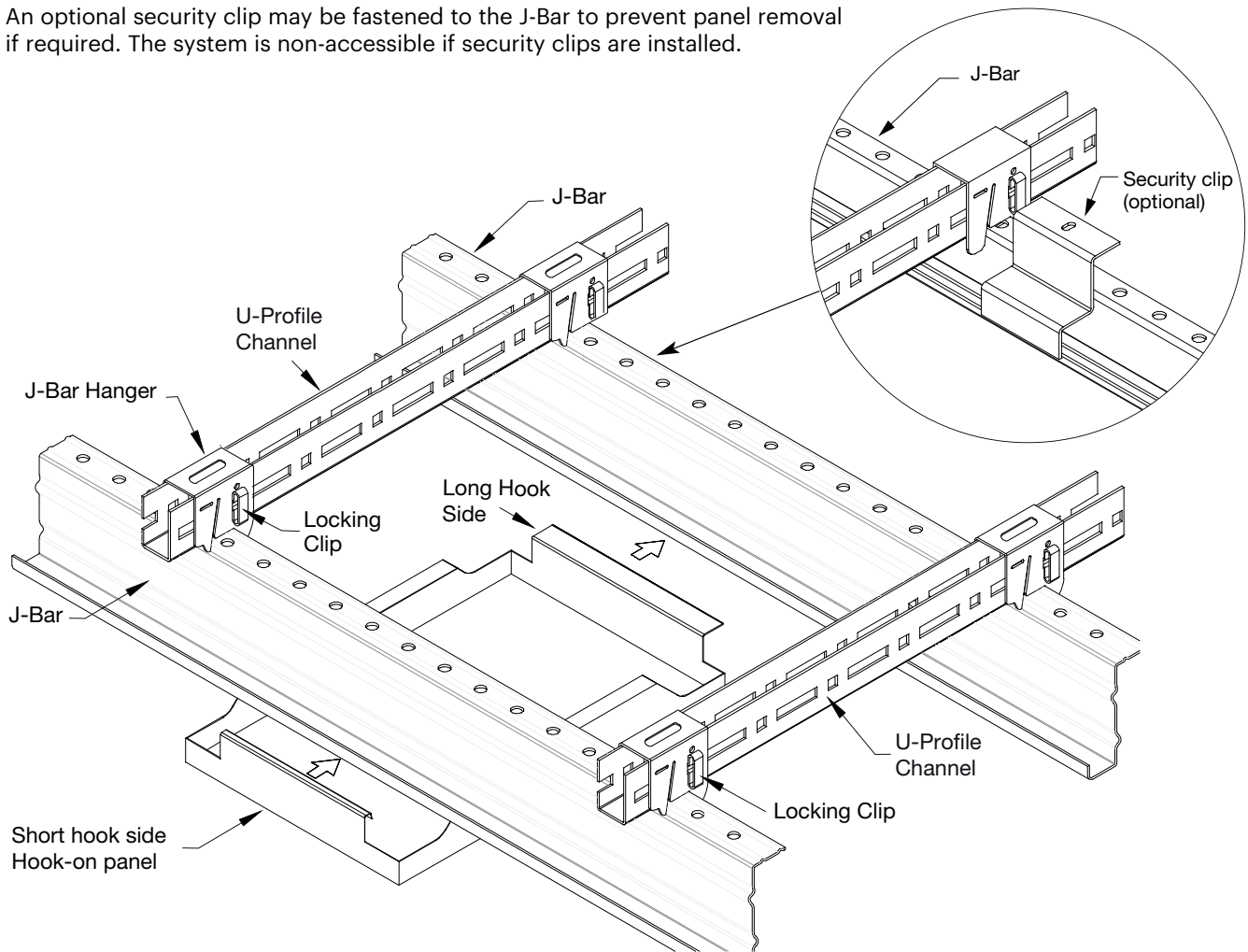

MetalWorks R-H200 Hook On

R-H200 Assembled Ceiling Detail

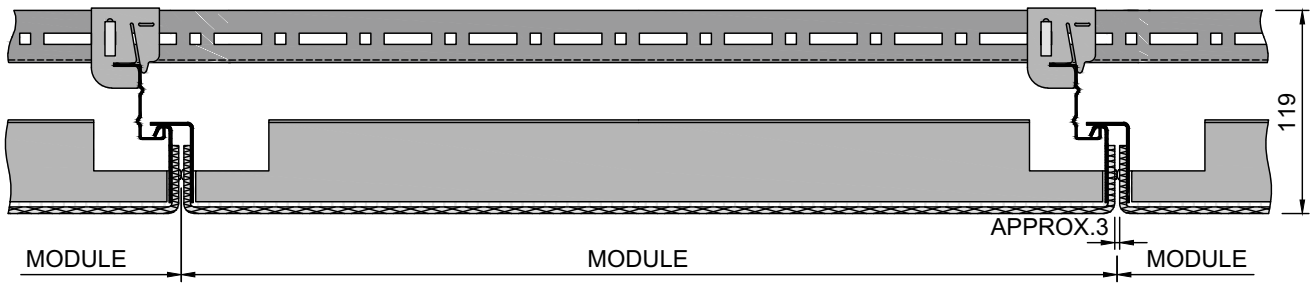

Panel Detail

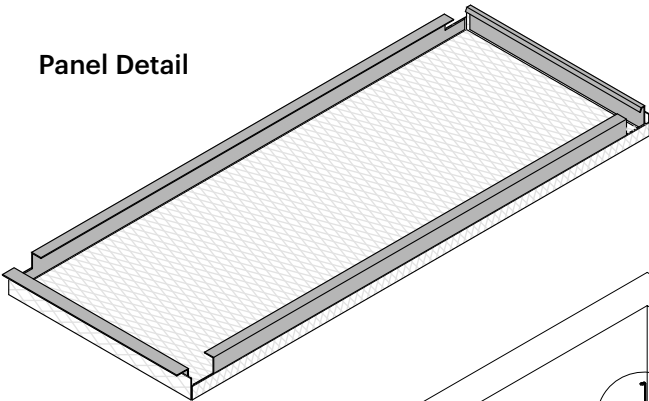

Edge Detail

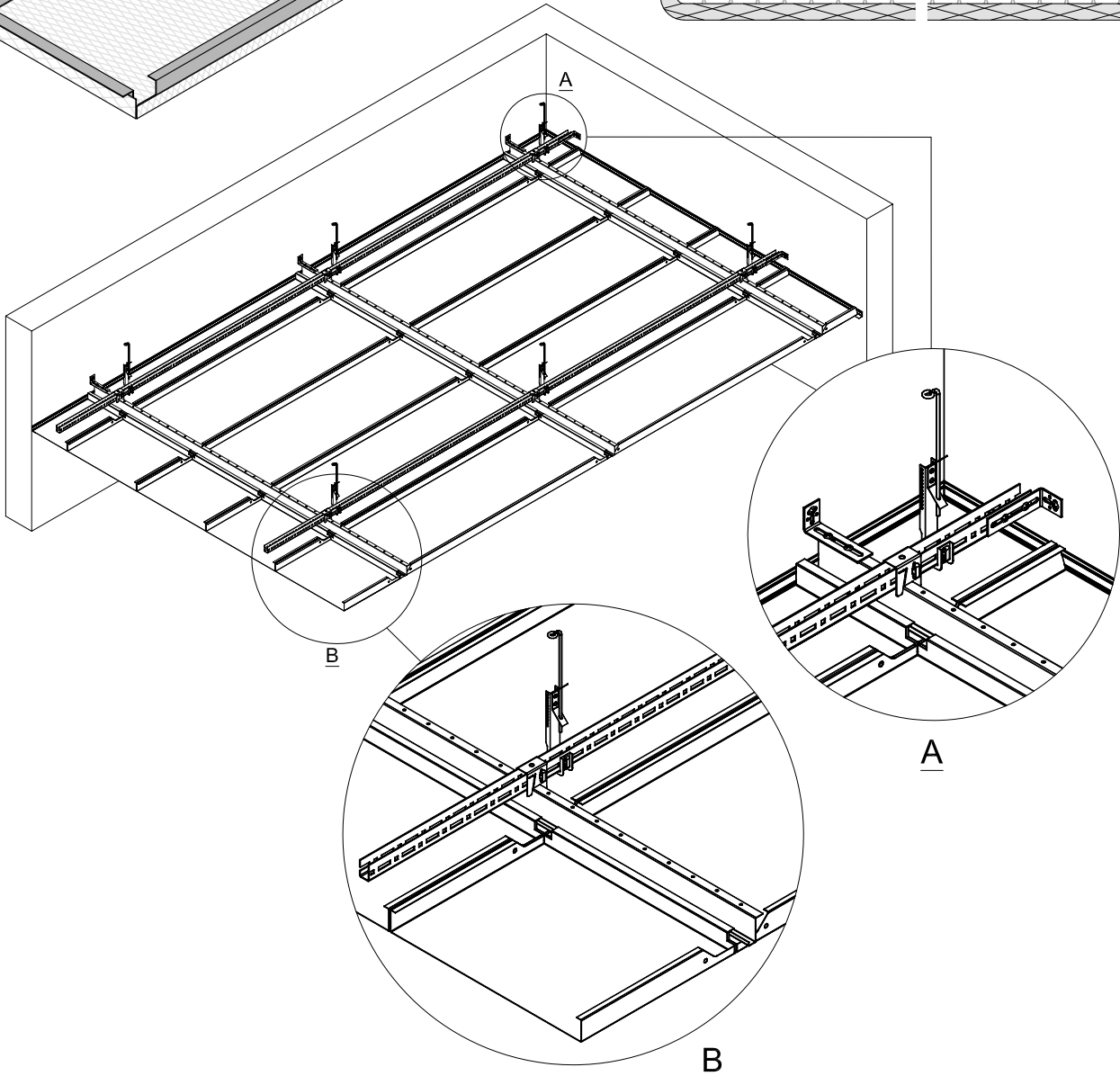
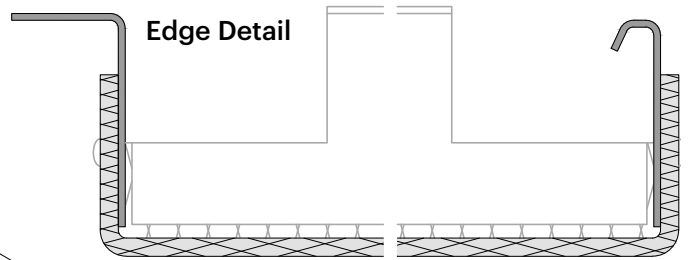

MetalWorks R-H200 Hook On

9. R-H200 Panel Installation and Removal

INSTALLATION OF METALWORKS RH200 PANELS

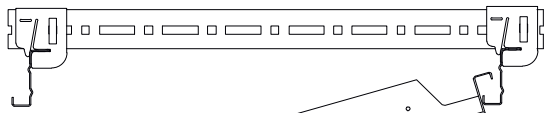

Step 1 - Fully insert the long hook side of panel above J-Bar.

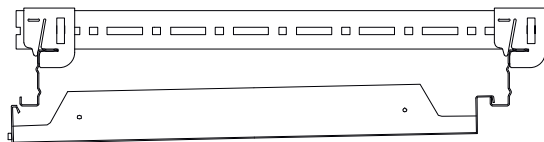

Step 2 - Raise short hook side of panel slipping up above J-Bar.

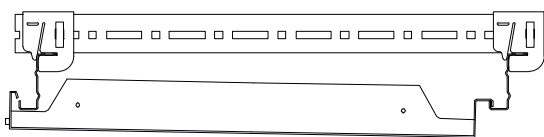

Step 3 - Make sure that short hook side lines up above before J-Bar sitting panel on J-Bar.

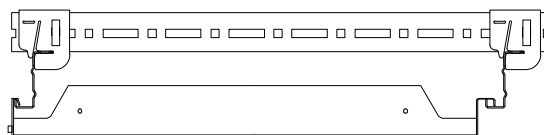

Step 4 - Lower MetalWorks panel onto J-Bar. Check panel(s) for J-Bar proper alignment.

REMOVAL OF METALWORKS RH200 PANELS

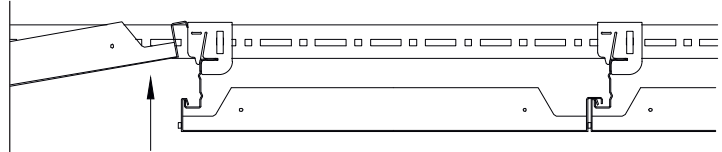

Step 1 - Carefully lift and hold adjacent panel edge.

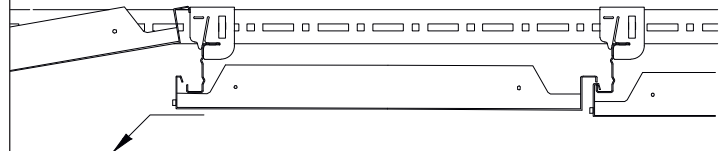

Step 2 - Raise desired panel for removal by lifting short hook side first (place free hand at middle of panel for best results). Next, slide panel toward short hook side and tilt panel down carefully past bottom of J-Bar. Lower adjacent pane back onto J-Bar.

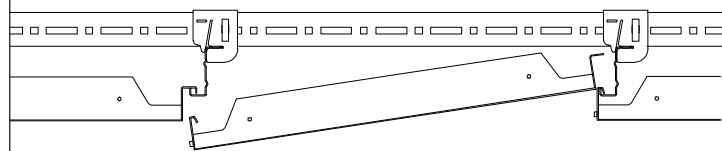

Step 3 - Raise long hook side up past top of hook, keeping panel at an angle J-Bar for removal.

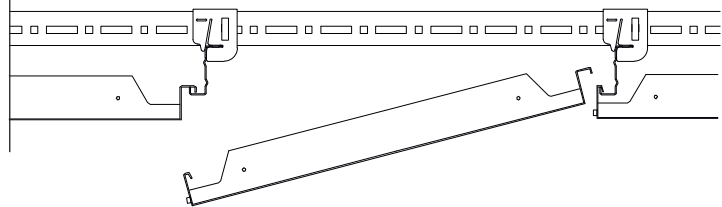

Step 4 - Lower MetalWorks panel from the ceiling. Place adjacent panel properly back onto J-Bar. Make sure panels are properly secured.

10. Light Fixtures and Services

- Lights fittings, depending on their weight are typically supported by the top of the U-Profile. Contact Armstrong Ceilings for specific load capacity.
- MetalWorks™ panels will not support any services.
- Please consult an Armstrong Ceilings Representative with reference to loadings on grid systems.

MetalWorks MESH R-H215 Hook

Installation Guide

The ceiling system is made up of Armstrong METALWORKS R-H215 Hook On In panels which are supported by the Armstrong Suspension System, comprising of: U-Profile Channels, H-Bar (Hook On Rails), Suspension Clips & hangers and Wall Angles located around the perimeter of the space..

The integrity of the entire suspended ceiling depends on the hangers – commonly 5mm gal rod is used, with some contractors using 2.5mm wire and M6 Threaded Rod (Both types meet Australian / New Zealand standard 2785-2020) which are used to support the main bars. Bracing is to be applied where required to ensure the U-Profile Suspension System remains square.

1. Before You Start

- All material delivered to site should be checked for damage, unopened and in its original packaging.
- At this stage if you are unsure of the suitability of material for this project, ask questions, as it is very expensive to remove materials that have been installed.
- All materials to be kept dry and protected from the elements.

2. Plenum Space

- The installation of METALWORKS R-H215 Hook On panels requires no more space in the plenum than that which is required to hang the suspension system. Panels never need to travel into the plenum space during installation or removal.
- The total height of the ceiling assembly is approximately 100mm measured from the face of the panel to the top of the U-Profile Channel. Additional space is required for the attachment of Suspension Clip and 5mm Rod.

3. Determine Ceiling Orientation

- It is important at this stage to determine the direction the ceiling grid and panels to be installed.
- The drawing supplied by the builder will show the panel direction required (rectangular panels).
- U-Profile Channels are typically oriented perpendicular to the roof purlins or joists.

4. Installation of Wall Angle

- Wall angle type is to be determined and installed at the ceiling height as described on the construction drawing.
- Mark the desired height of the wall molding. Use a chalk line or laser to mark all walls at the same height.
- Wall angles to be fixed up to a maximum of 600mm centers to the building structure;
- The type of fixings to be used will be determined by the type of building base material used.
- Ensure all butt joints are tight and miters in corners are also neat and tight.

For Seismic Design support please contact your local Armstrong Ceilings office

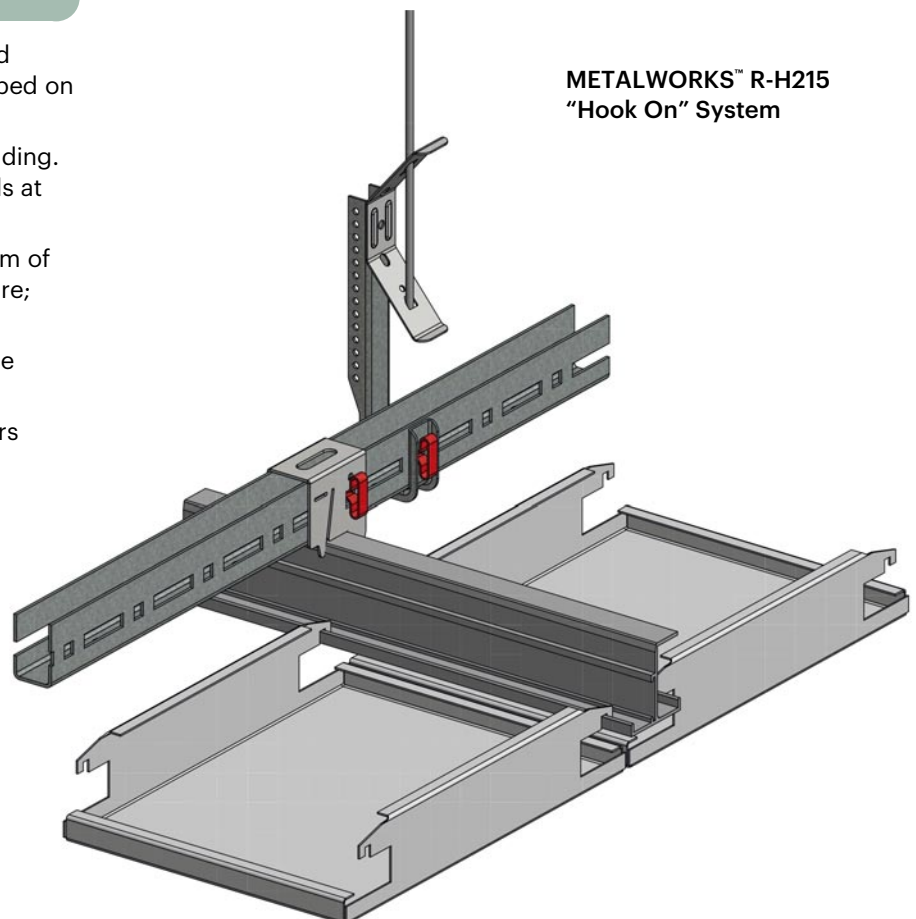

MetalWorks R-H215 Hook On

5. Installation Of Hangers and U-Profile

- The 5mm Gal rod shall to be cut to pre-determined lengths, and a hook bent to 30° on one end (must be a sharp bend, so the suspension bracket will fit into the bend without the rod straightening).

Where specified, the U-Profile Channel can be suspended on 6mm galvanised threaded rod. See Fig. 2 for details (Suspension Clip for Threaded Rod is Item UNITRCB).

- Fit the Suspension Clip to the rod at this stage and fasten with Locking Clip (item UNI200).
- The Locking Clip is correctly fitted with the longer tongue face up (see Fig 1). The Locking clip can be removed by pressing down on the upper tongue.

Fig. 1: Locking Clip Installation

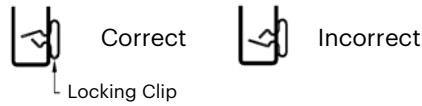

- If using 2.5mm Suspension Wire, bend the wire around the U-Profile Channel and wrap it around itself 3 times.
- Ensure all suspension rods are vertical.
- When installing the ceiling under a metal roof structure, ensure the U-Profile Channels (Item UNI111B) run at perpendicular to the purlins / trusses.
- Install U-Profile Channels at 1200mm (maximum) centres with Suspension Hangers (5mm Rod and Clip) at 1200mm (maximum) centres along the length of each U-Profile Channel. Ensure Locking Clips are installed to secure the Suspension Clip to the Unigrad Channel. See Fig. 2 for details and specific components: 5mm Rod, Suspension Clip (item UNI203B) and Locking Clip (item UNI200)

Fig. 2: U-Profile Channel and Suspension Components

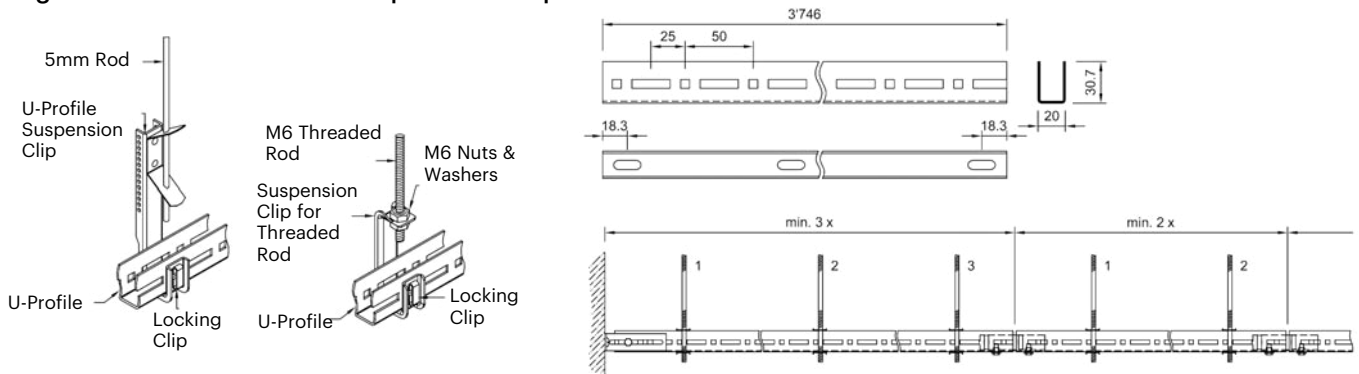

- The U-Profile Channels adjacent to the perimeter must have three suspension points, with the other U-Profile Channels in between requiring a minimum of two suspension points.
- U-Profile Channels are to be secured to the perimeter with the U-Profile Wall Anchor Bracket (Item UNI202) See Fig. 3 for details

Fig 3: U-Profile Detail at Perimeter

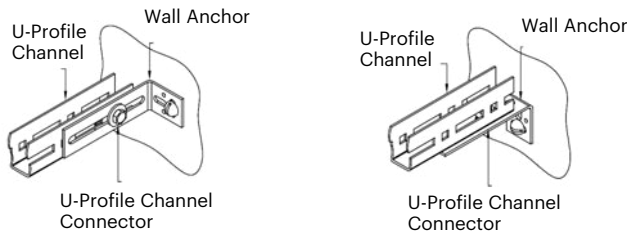

- U-Profile Channels are to be joined end to end with a U-Profile Channel Connector (Item UNI103). See Fig. 4
- To ensure the U-Profile Channels are kept precisely on module, tolerances in the U-Profile Channel can be absorbed in the joint with the connector.

Fig 4: U-Profile Channel and Connector

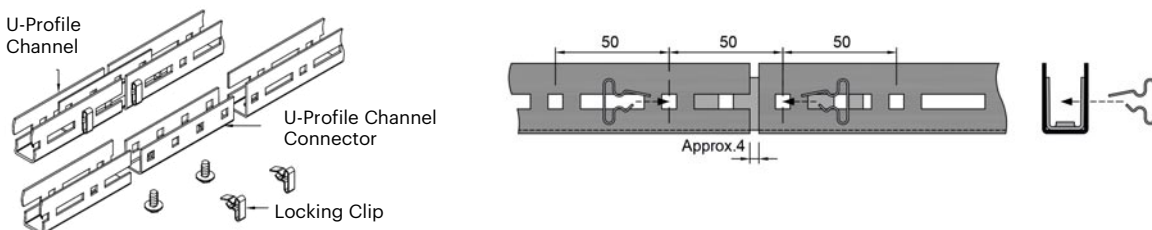

MetalWorks R-H215 Hook On

5. Installation Of Hangers and U-Profile (Continued)

- The 1st Unigrig Channel must be no more than 300mm from the perimeter, with the first suspension point being no greater than 300mm from the end of the Unigrig Channel.
- The U-Profile Channels are to be installed parallel, in a manner that the punchings along the length, align from one U-Profile Channel to the next. Note: the Unigrig Channels are directional and punched on both sides at 50mm OC, and 25mm offset. See Fig. 2 for details.
- It is recommended that main bar joins should be staggered to increase the strength of the system.

6. H-Bar Installation

- Locate H-Bar "Hook-On" Rails (Item HBAR3600) according to panel size: For 1200 long panels, locate H-Bars at 1200mm centres; 1500mm long panels at 1500mm centres and so on.
- Each H-Bar is suspended from the U-Profile Channel using "H-Bar Hangers" (item UNI112S)
- H-Bar Hangers install over the Unigrig Channel and are secured with Locking Clips (item UNI200. Refer Fig. 6b).
- The top leg of the H-Bar inserts into the slot in the H-Bar Hanger and secured by folding down both wings of the H-Bar Hanger.
- H-Bars are joined end to end with H-Bar Connectors (item UNI 101). Refer to Fig. 6a for details.

7. Components

Item Number	Description
UNI111B	U-Profile Channel (3750mm)
UNI103B	U-Profile Channel Connector
HBAR3600	H-Bar for RH215 (3600mm)
UNI101	H-Bar Hanger
UNI112S	H-Bar Connector
UNI203B	Suspension Clip for 5mm Rod
UNITRCB	Suspension Clip for M6 Threaded Rod
ROD 5mm	5mm Suspension Rod
UNI200	Locking Clip
AL008RCPSW	Std "L" Wall Angle
AL009RCPSW	Shadowline Wall Angle
UNI202	U-Profile Wall Anchor Bracket

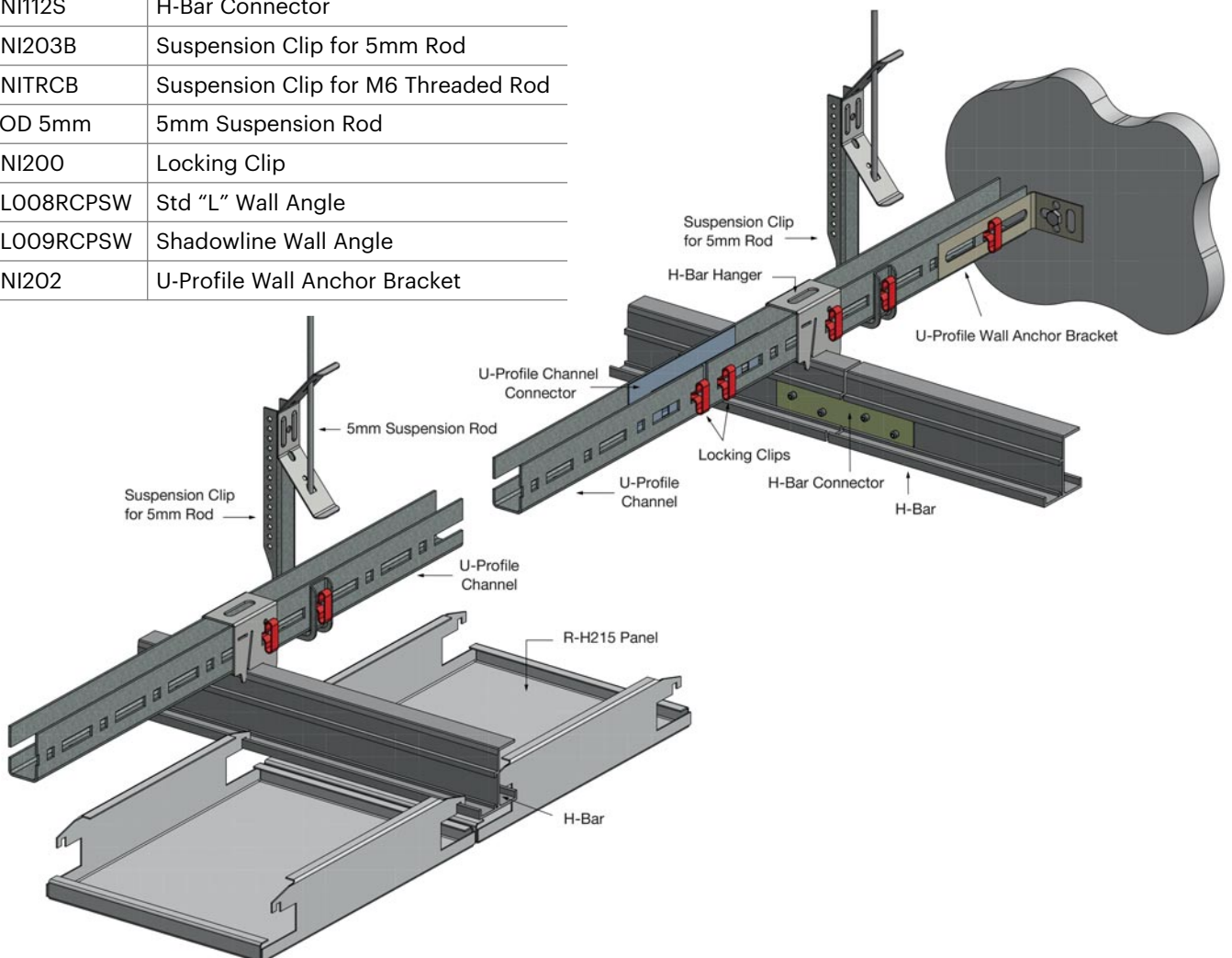

MetalWorks R-H215 Hook On

R-H215 Assembled Ceiling Detail

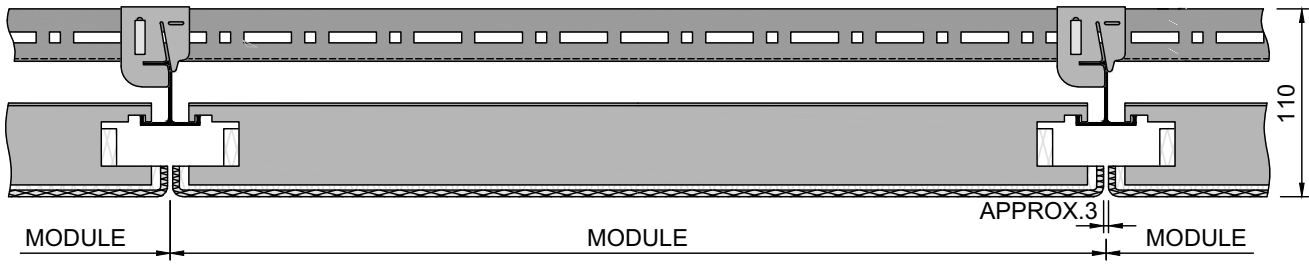

Panel Detail

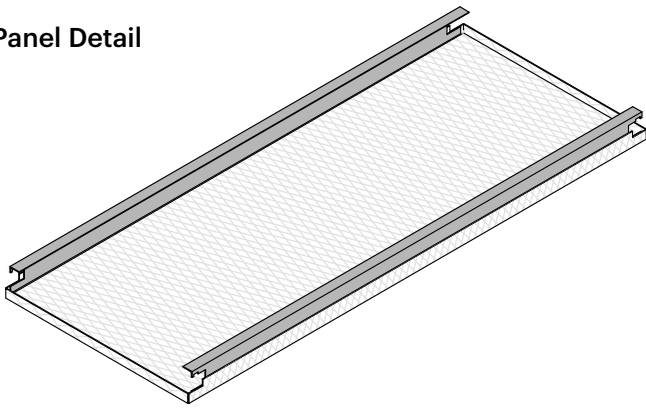

Edge Detail

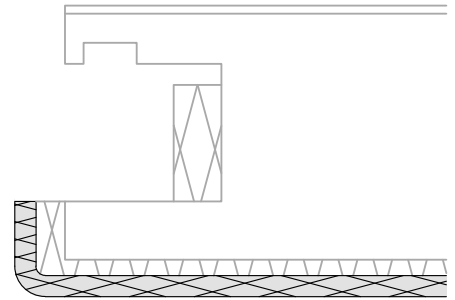

Longitudinal Section

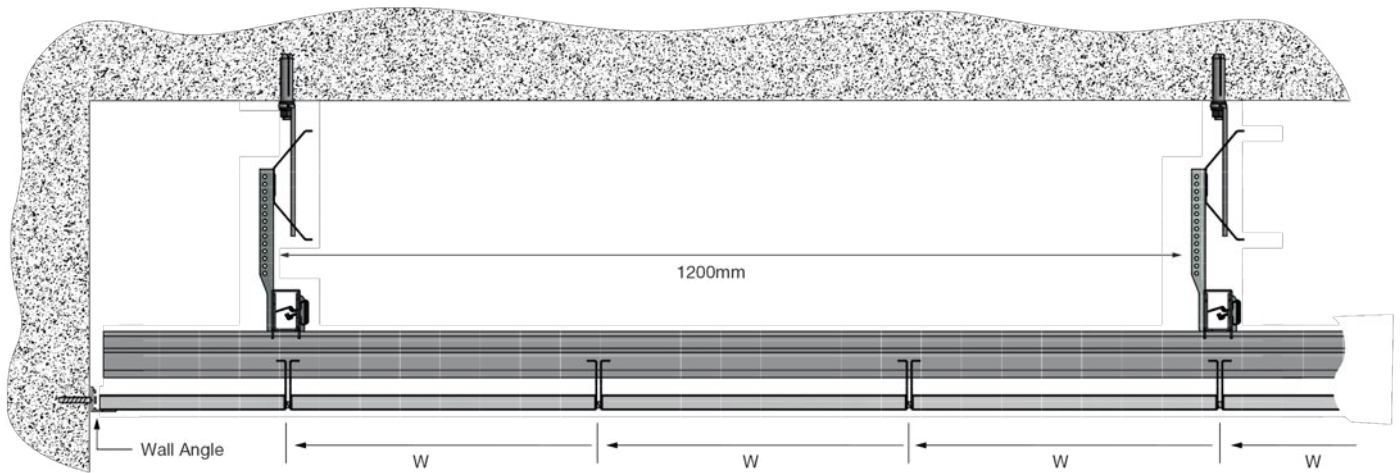

W = Panel Width
L = Panel Length
Module = Panel Width / Length + 3mm

MetalWorks R-H215 Hook On

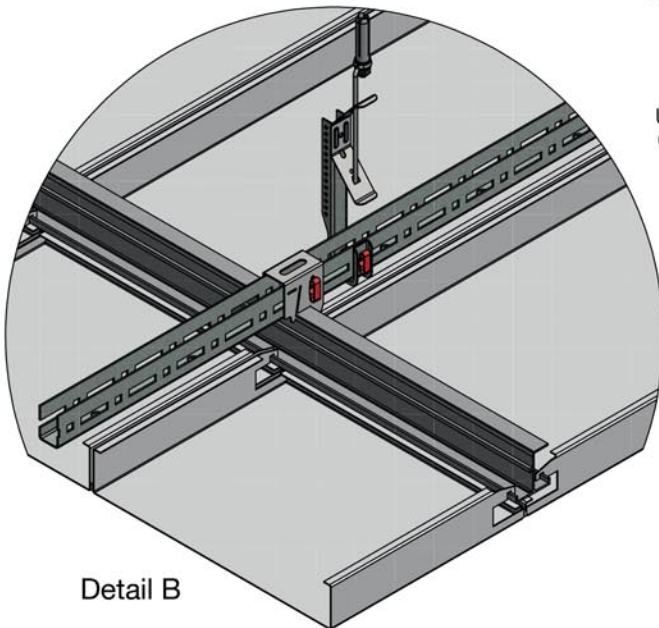
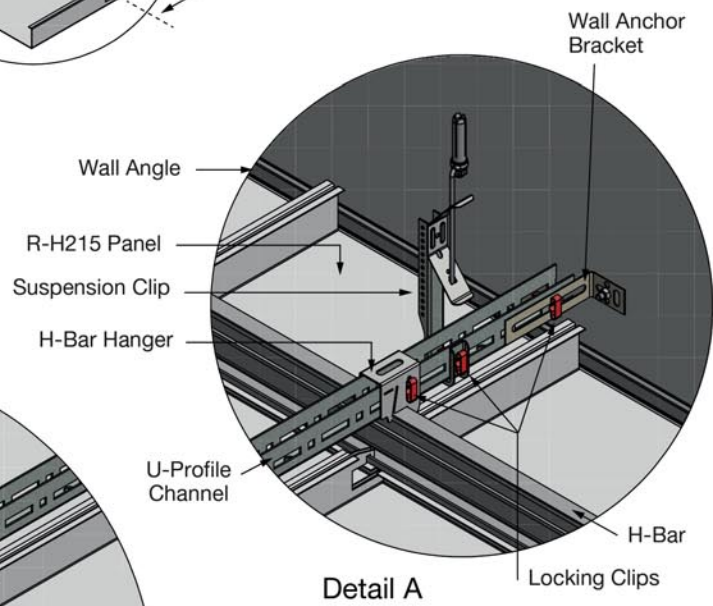
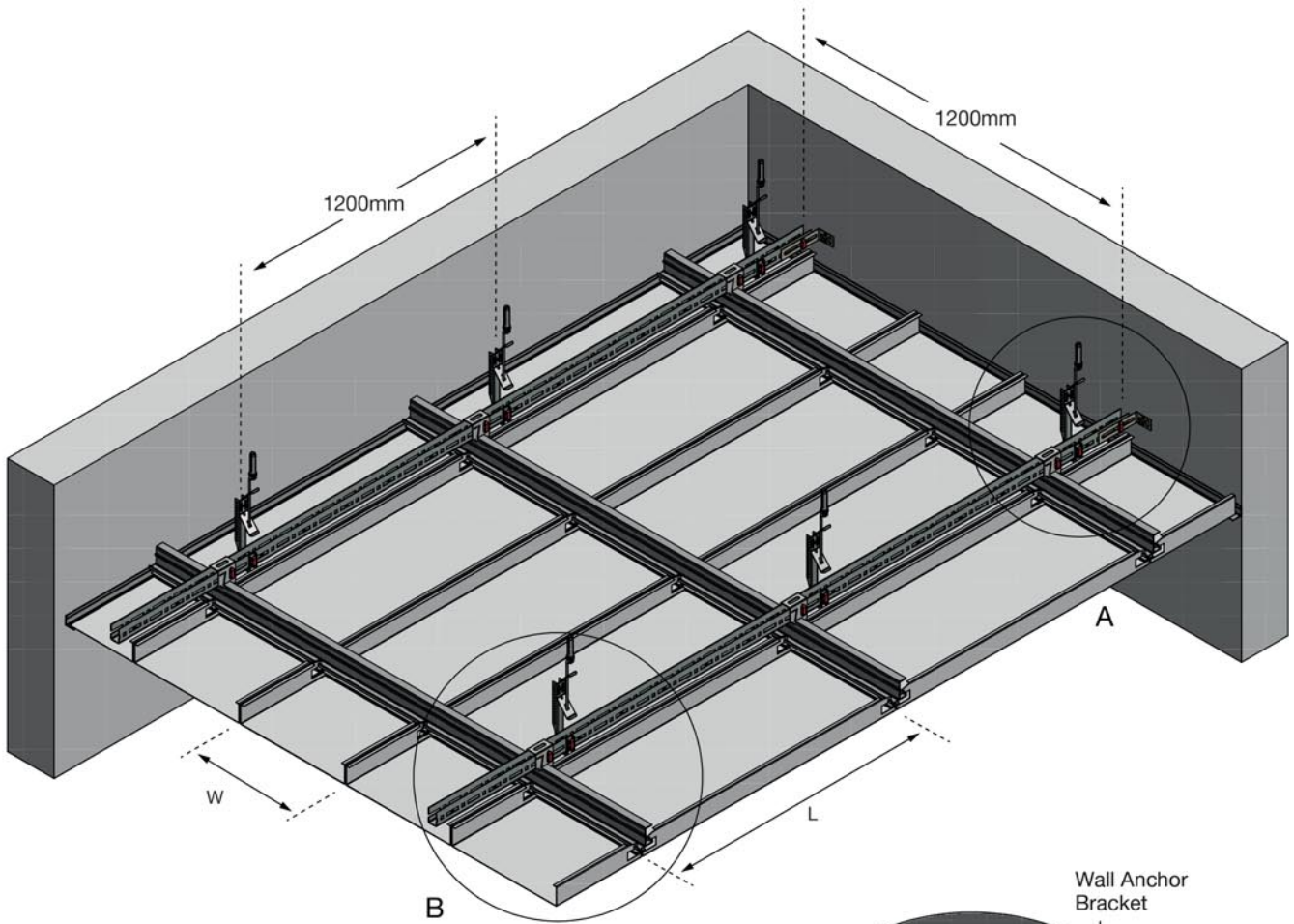

Note: Please refer to the
Armstrong METALWORKS™ R-H215
Brochure for specification and performance details

MetalWorks R-H215 Hook On

9. Square the Grid, Bracing Requirements and Levelling

- Measure across the diagonals of the opening. The measurements will be the same if the grid is square.
- Depending on the size of the ceiling and design details there could be a requirement for bracing to hold the grid square and to stop grid movement during installation.
- The amount of bracing required is to be determined onsite by the installer.
- The ceiling system can be levelled by adjusting the suspension clip up and down with the use of a laser.

10. Ceiling Panel Installation

- The ceiling grid is now ready for ceiling panels. See illustration for installation (and removal of panels).
- Measure and cut boarder tiles individually. Refer Cutting Options below for details.

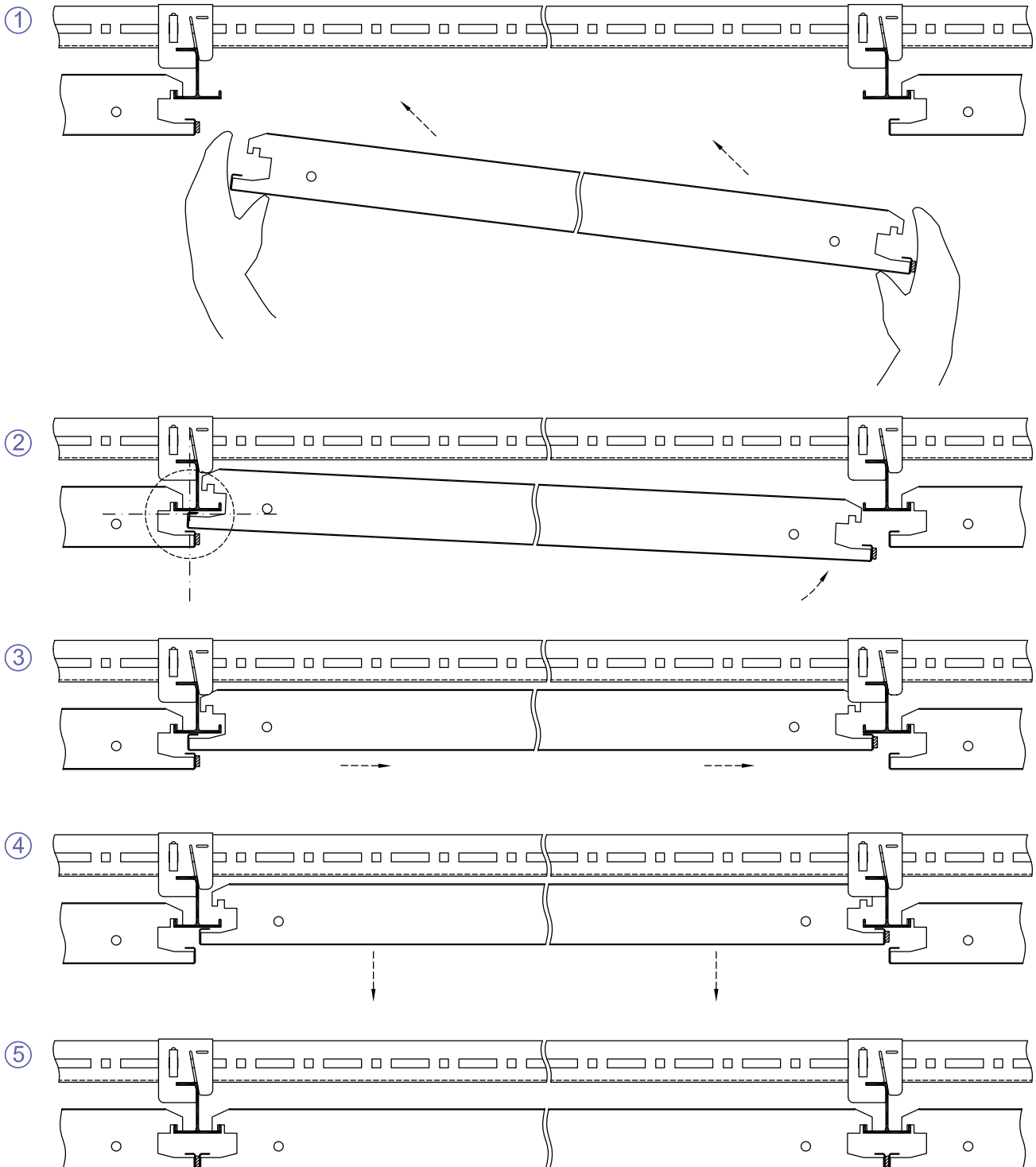

MetalWorks R-H215 Hook On

11. Light Fixtures and Services

- Lights fittings, depending on their weight are typically supported by the top of the U-Profile. Contact Armstrong for specific load capacity.
- MetalWorks panels will not support any services.
- Please consult an Armstrong Representative with reference to loadings on grid systems.

12. Panel Removal

All panels are removable without moving up into the plenum. Refer to illustration below for Panel removal steps.

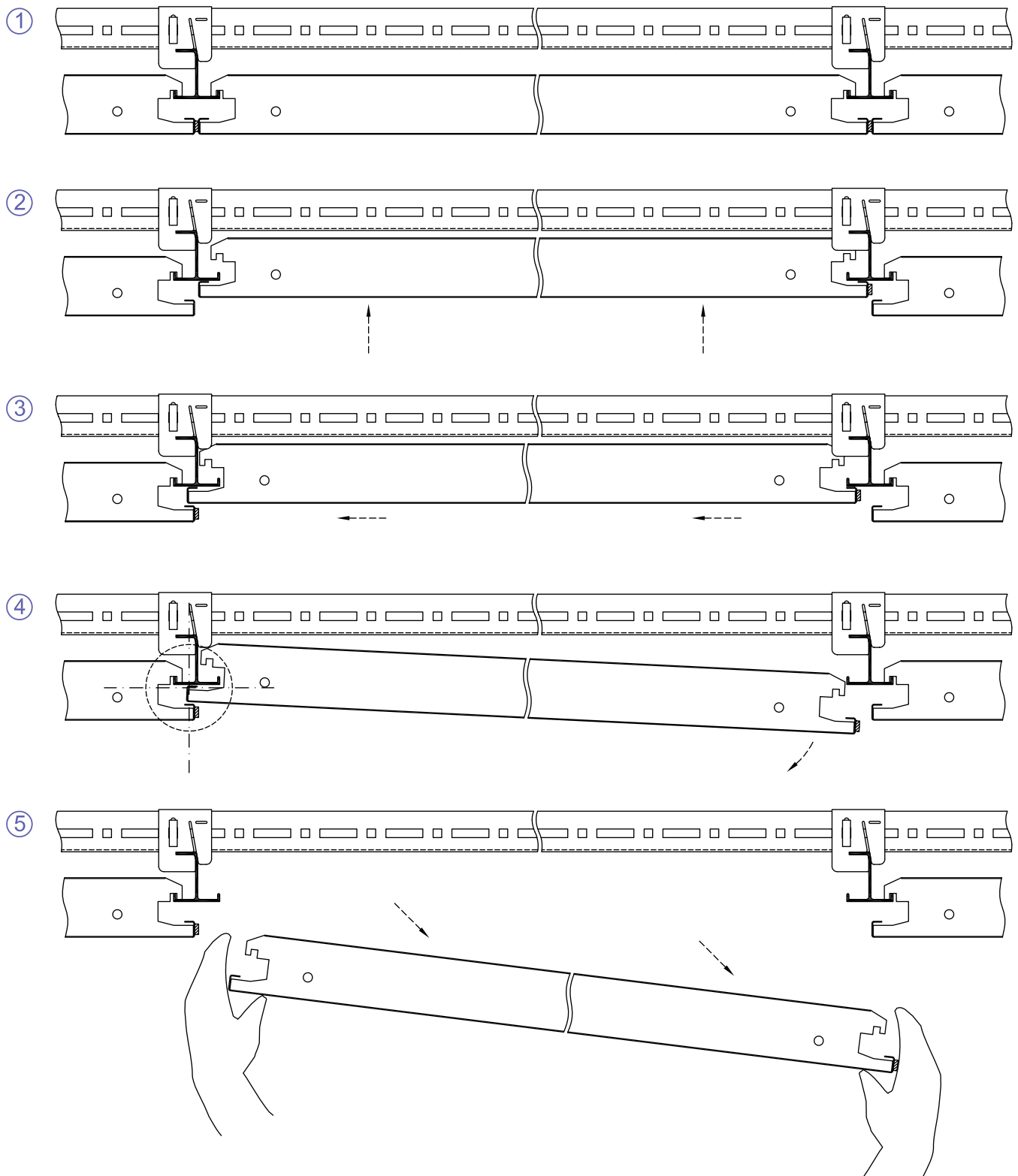



Contact us

NSW/ACT

Armstrong Ceiling Solutions (Australia) Pty. Ltd.
75 Long Street, Smithfield, NSW, 2164
Telephone (02) 9748 1588

VIC/TAS

Armstrong Ceiling Solutions (Australia) Pty. Ltd.
Unit 1, 88 Henderson Road, Rowville VIC 3178
Telephone (03) 8706 4000

QLD / NT

Armstrong Ceiling Solutions (Australia) Pty. Ltd.
6 Barrinia Street, Slacks Creek QLD 4127
Telephone (07) 3809 5565

SA

Total Building Systems Pty. Ltd.
160 Grand Junction Road, Blair Athol SA 5084
Telephone (08) 7325 7555

WA

Ceiling Manufacturers of Australia Pty. Ltd.
3 Irvine Street, Bayswater WA 6053
Telephone 08) 9271 0777

New Zealand

Comfortech Building Performance Solutions®
27B Smales Road, East Tamaki, Auckland 2013
Telephone 64-9-276 4000

CEILING SOLUTIONS