



Commercial Offices  
Call Centres  
Hospitals  
Hotels  
Resorts  
Fitness Centres  
Sports Clubs  
Recreational Clubs  
Public Spaces  
Industry  
Transport Hubs  
Security Checkpoints  
Correctional Centres  
Warehouses



## INTERLOC

Interloc delivers sophisticated and secure storage solutions from the forefront of locker design and manufacturing. As a family-owned business, we combine sterling quality with excellent, reliable customer service, working closely with you to tailor a solution to your needs. Boasting over 50 years in the manufacturing industry, the Interloc team excels in providing quality storage facilities for commercial, educational, hospitality, recreation, fitness, sporting and a range of other environments.

Our core values are security, style and service. We take an innovative approach to locker design, manufacturing and installation, providing premium quality locker units or full locker systems that can be seamlessly integrated into any environment. And with a range of functional, low-maintenance and comfortable seating options, we can help you create the perfect locker room for your needs.

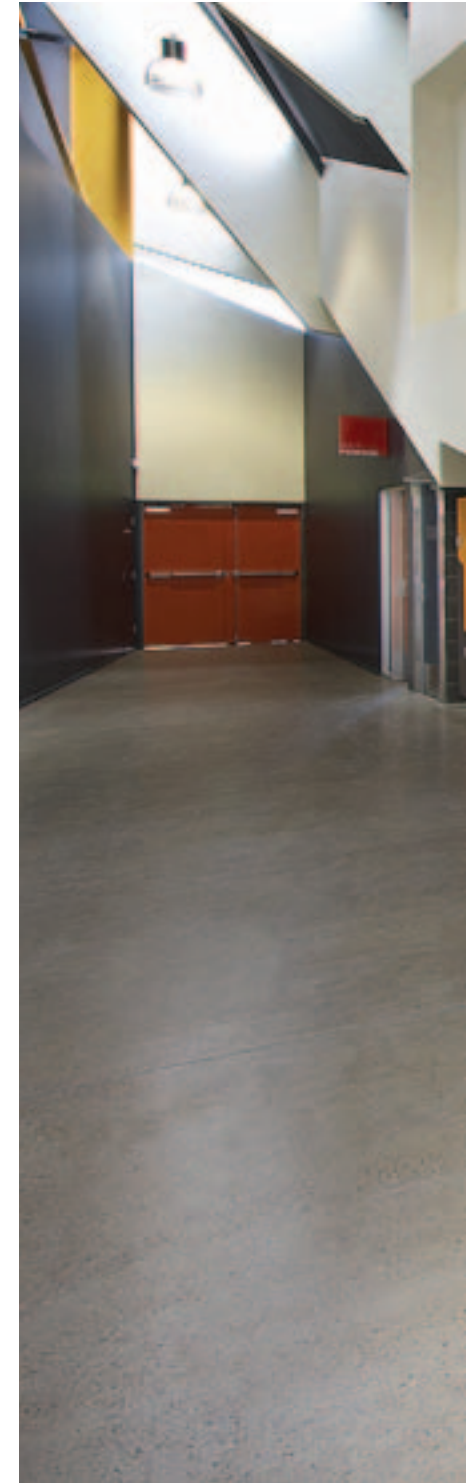



## CONTENTS

Premium Lockers	4-5
Premium Specifications	6-7
Custom Lockers	8-9
Mini, Plastic & Steel Lockers	10-11
Smartcard Locking	12-13
Locking Systems	14-15
Seating	16-17
Seating Specifications	18

## PREMIUM LOCKERS

Our elegant timber laminate lockers are our most popular design. Practical, sturdy and versatile, they can be used for a wide range of applications, from recreation and sporting environments, right through to educational, hospitality, commercial and industrial areas.

With a range of laminate colours and different board types, our timber locker range is entirely customisable to your needs and preferences. Choose from a selection of different door sizes, from rectangular, to mini-sized, to interlocking wave shapes. We offer a fully tailored finish for each installation, with diverse locking options and a range of accessories including mirrors, shelving, hanging rails, ironing boards and hooks available to enhance user convenience.

Our Timber Laminate Lockers have met **Ecospecifier's Level A GREEN TAG™ GreenRate Certification** requirements.





# Premium Specifications

## Rectangular Locker Doors

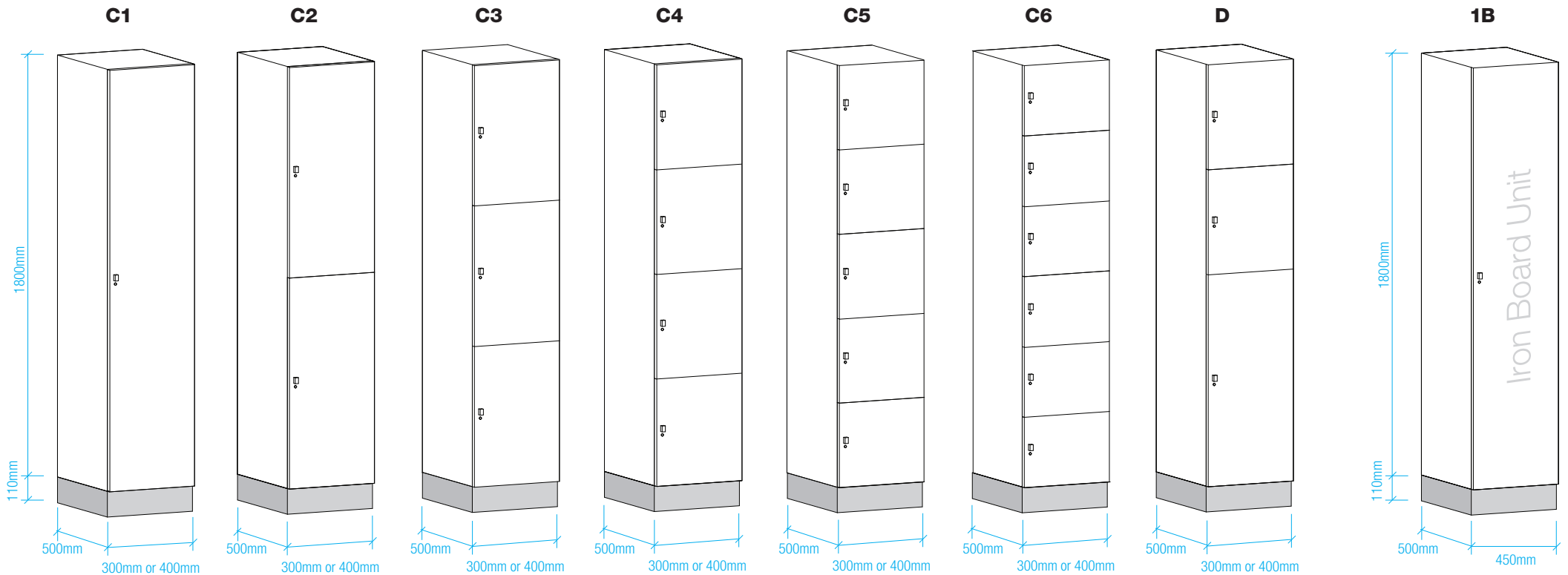

Code	Locker Type	Locker Description	Hanging Height	Door Height	Standard Locker Options
<b>C1</b>	Square 1 Door	Single door locker unit, conventional style with hat and hanging space. Any application.	1400mm	1800mm	<ul style="list-style-type: none"> <li>• Standard key or padlock receptor.</li> <li>• Door numbering and key tags.</li> <li>• Coat hangers and hanging hooks.</li> <li>• Rear vent to all locker carcasses.</li> <li>• 110mm high plinth.</li> <li>• Black pull knob.</li> </ul> <p>These represent standard locker options and may have specific options added as required per project.</p>
<b>C2</b>	Square 2 Door	2 door locker unit, hanging rail. Any application.	865mm	900mm	
<b>C3</b>	Square 3 Door	3 door locker unit, large bag storage.	-	600mm	
<b>C4</b>	Square 4 Door	4 door locker unit, bag storage.	-	450mm	
<b>C5</b>	Square 5 Door	5 door locker unit, small bag and personal items.	-	360mm	
<b>C6</b>	Square 6 Door	6 door locker unit, personal items and shoes, etc.	-	300mm	
<b>D</b>	Square 3 Door	3 door locker unit, combination 1/2 size and 1/4 size lockers. Hanging and bag storage.	-	900/450mm	
<b>1B</b>	Ironing Board Unit	1 door locker unit, ironing board unit.	-	1800mm	

### Standard Inclusions

- \* Carcass includes E0 white HMR as standard with black ABS edging.
- \* All doors manufactured from Formica, Laminex E1 with E0 available in a range of colours.
- \* All lockers are 500mm in depth.

# Premium Specifications

## Wave Locker Doors

Designs B, BH, GT, GB & G ® Registered and only available from Interloc.

## Lockers with Seating

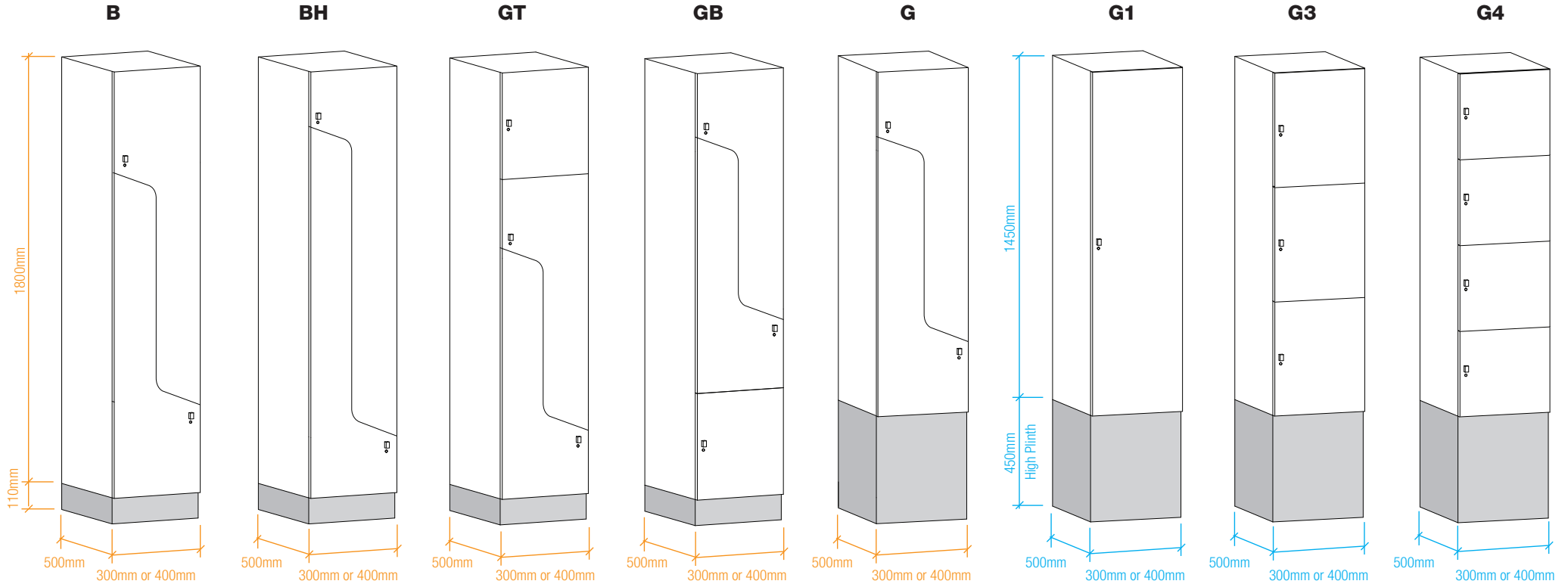

Code	Locker Type	Locker Description	Hanging Height	Door Height
<b>B</b>	IL Long Neck	Door interlocking type. Long hanging length. Suitable : bag - shirts & pants hanging etc.	1165mm	1180mm
<b>BH</b>	IL Extra Long	2 door interlocking type. Extra long hanging length. Suitable : uniforms & dresses	1280mm	1300mm
<b>GT</b>	IL Top Locker	2 door interlocking type. 1 bag or shoe locker above.	950mm	965/350mm
<b>GB</b>	IL Bot. Locker	2 door interlocking type. 1 bag or shoe locker below.	950mm	965/350mm
<b>G</b>	IL High Plinth	2 door interlocking type. Designed to allow seating to front.	950mm	965mm
<b>G1</b>	Square 1 Door	Single door locker unit. Hanging and bag storage. Designed to allow seating to front.	1415mm	1450mm
<b>G3</b>	Square 3 Door	3 door locker unit. Bag storage. Designed to allow seating to front.	-	483mm
<b>G4</b>	Square 4 Door	4 door locker unit. Bag Storage. Designed to allow seating to front.	-	362mm

### Standard Locker Options

- Standard key or padlock receptor.
- Door numbering and key tags.
- Coat hangers and hanging hooks.
- Rear vent to all locker carcasses.
- 110mm high plinth.
- Black pull knob.

These represent standard locker options and may have specific options added as required per project.

### Standard Inclusions

- \* Carcass includes E0 white HMR as standard with black ABS edging.
- \* All doors manufactured from LMX Formica, Laminex EI with E0 available in a range of colours.
- \* All lockers are 500mm in depth.

## CUSTOM LOCKERS

If you have particular space requirements, or just need something a little different, Interloc provides a unique service to ensure your needs are met. Tell us what you have in mind, and we'll work closely with you to deliver a custom-made locker unit or full locker system that really suits your purposes and environment.

Whether it be the height, width, depth or internal fixtures, we can adjust the standard features and dimensions of any of our locker units, tailoring the perfect solution for your individual requirements. You can also choose from a range of accessories designed to enhance user experience. From mirrors, shelving and hooks, to larger additions like ironing boards. Whatever your needs, Interloc can provide a secure, stylish solution.









## MINI LOCKERS

For secure storage in confined spaces, our sophisticated mini lockers are the solution you need. Perfect for nightclubs, gyms, offices, or any environment with limited storage space, these compact units are just large enough to provide safekeeping for small personal items like wallets, keys, purses and phones.

Space-saving and functional, these small, wall-mounted units can be easily integrated into any public or private area. Aluminium brackets hold and connect each bank, with end panels ensuring additional strength and stability. And with a range of locking options available, they can be suitable for either single or multiple users in all different applications.



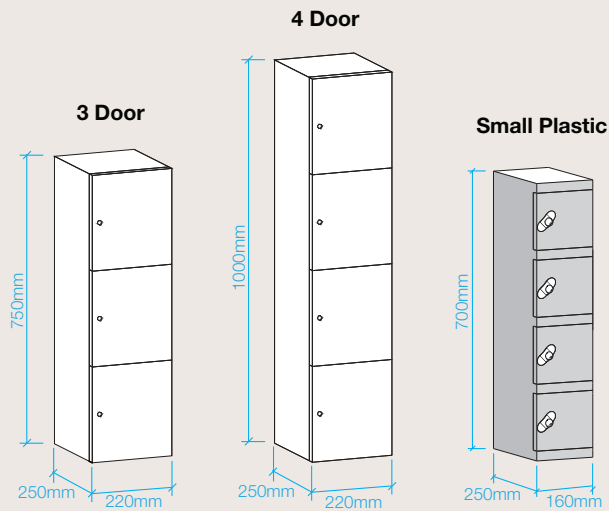

## ABS PLASTIC LOCKERS

With a sleek, plastic body and stainless steel hinges, our plastic lockers are specially designed for environments that are exposed to regular wetness or humidity. A new addition to the Interloc range, this innovative design provides a practical solution for aquatic centres, changing rooms, resort pools, outdoor areas, commercial kitchens, and other areas where timber and steel have proven unsuitable.

Low-maintenance and easy to clean, our plastic lockers offer convenience. Individual units can be stacked or arranged in a wide range of configurations to suit your space requirements. Optional numbering and a choice of locking systems allow you to further customise your lockers to your specific needs.

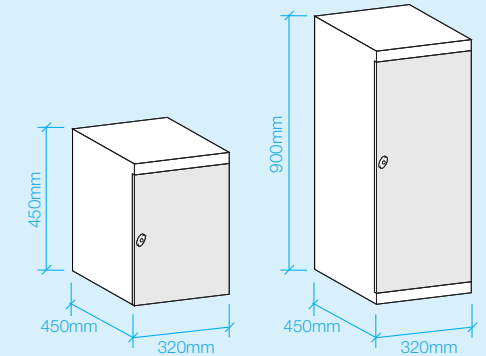

## STEEL LOCKERS

Sturdy and functional, Interloc steel lockers are a great economical choice. For a simple and cost-effective installation, our powder-coated steel design is suitable for a wide range of environments, particularly those requiring heavy-duty use.

Choose from a range of door configurations and customise your design with your choice of standard barrel locks or padlock receptors. Our standard steel lockers are freestanding, but can be ganged in any number or combination to suit your space requirements, and either be installed directly onto the floor surface, or fitted to an adjustable plinth.

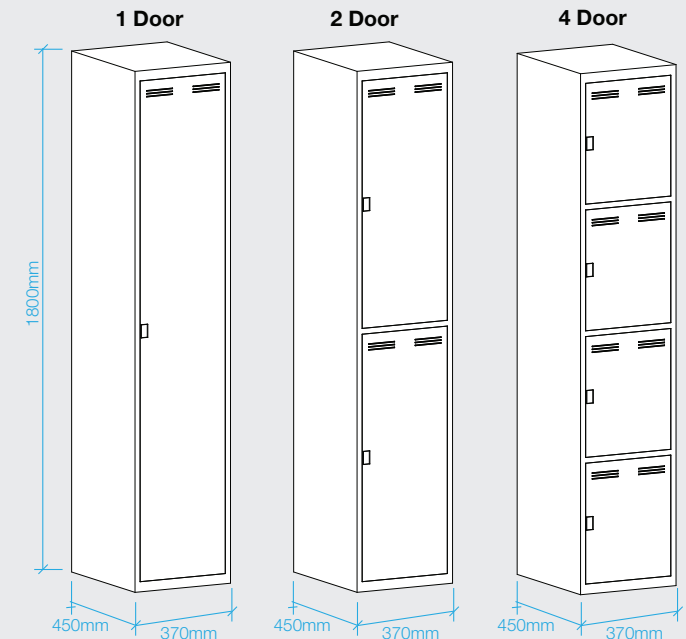

## SMARTCARD LOCKING

We all understand the importance of smart technology for our business operations. Smartcard technology for locking and access control is the world standard. Interloc provide hardwired solutions where all locks are networked together and managed by user friendly monitor and control software or stand alone battery powered locks for smaller installations requiring smart capabilities.

Each smart lock reads high security smartcards or bands and also writes information into the card or band each time. This function provides many unique features for 'Free Locker' and 'Personal Locker' configurations. If you require smart locking for maximum manageability, convenience and security for your clients, talk to us about smart card locking.

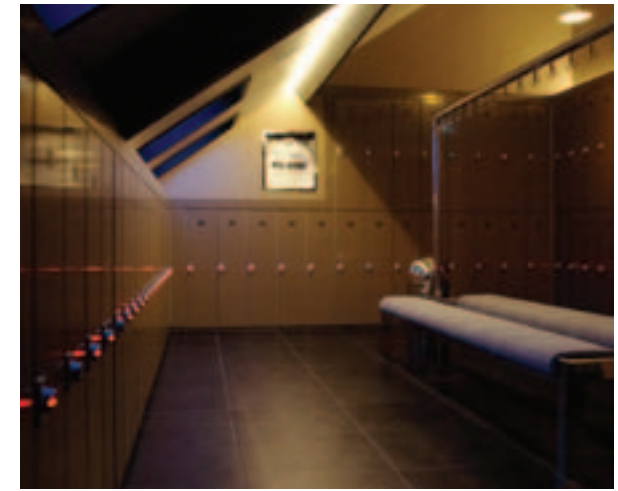
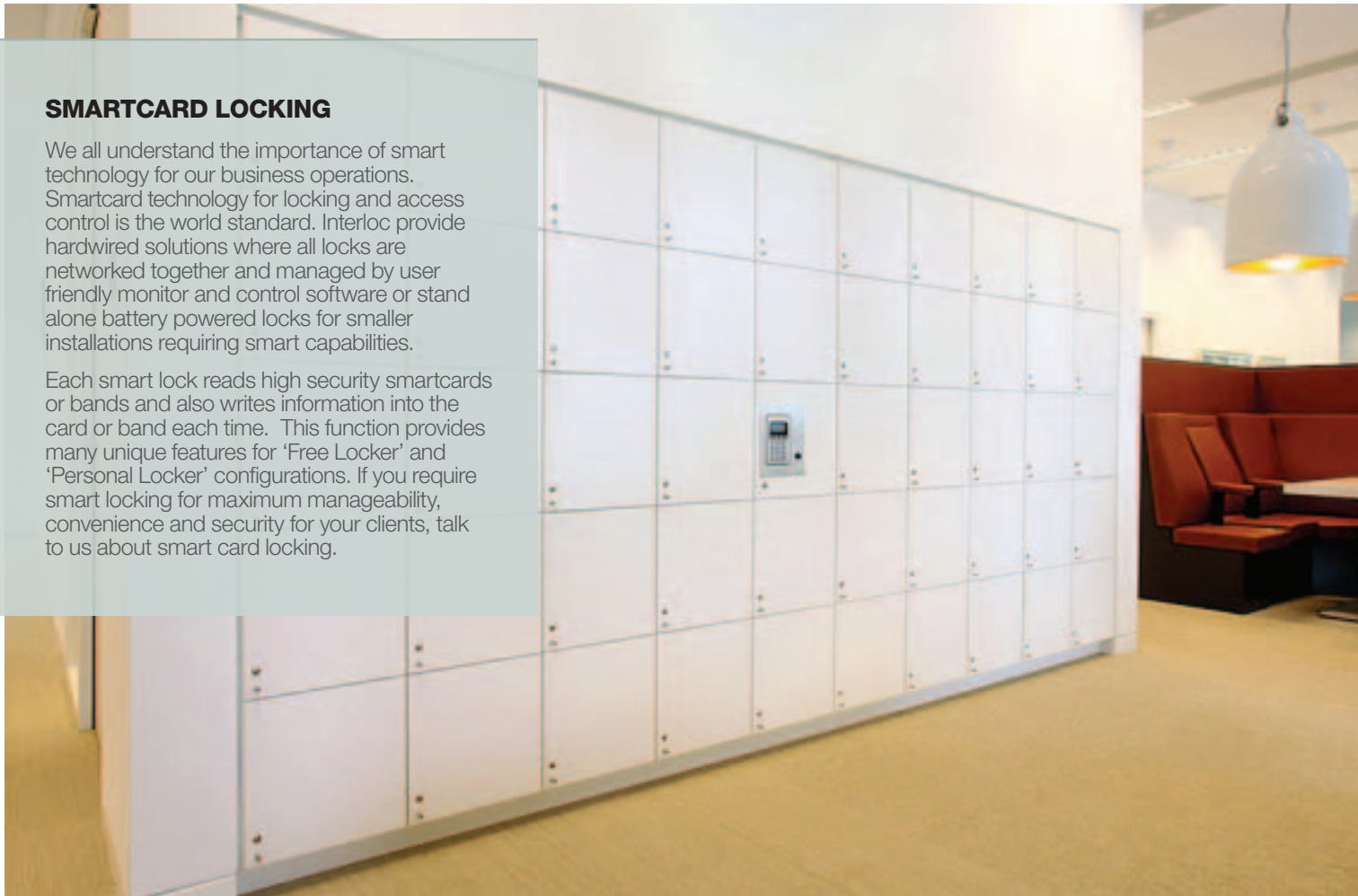



## LOCKING SYSTEMS

Even the best locker is useless without a reliable lock. Create peace of mind and keep your storage units secure with a dependable, quality locking system. Whether it's a single user or sharing environment, Interloc provides real security and style, with a range of premium quality locking solutions to suit any application or budget. From classic barrel locks to sophisticated digital systems, we can customise your lockers to match your specific needs. Simple or elaborate, we have the solution.





### BARREL LOCKS

These keyed entry locks offer a dependable level of security, and can easily be configured in any typical installation. This is a great option for applications with multiple users. Barrel locks come with two keys, with a master key and barrel removal device also available on request.



### PADLOCK RECEPTORS

Simple and secure, this classic locking solution is perfect for single-user applications, like in schools, offices, and even some gyms and clubs.



### DIGITAL KEYPAD LOCKS

A sophisticated, reliable and proven keyless entry solution. Digital locks are operated by any 4-digit code that can be reset with each use. Keypads are self-contained and battery-powered.



### DIGITAL TIMED KEYPAD

All the benefits of the Digital Keypad Lock with an added timing function, allowing the operator to place time limits on the use of the locker.



### COIN (RETURN)

A convenient and popular system for shared-use lockers, this lock releases the key when a coin is inserted into a secure capture mechanism. On completion of use, the key is retained and the coin is returned to user.



### COIN (RETAIN)

Again, popular for shared-use lockers however coin payment is retained rather than returned to the user. Allows the operator to generate revenue from the lockers.



### SMARTCARD BATTERY LOCK

Battery locks provide flexible options for 'free locker' or 'personal locker' arrangements based on smartcard technology. The compact standalone units are powered by AA batteries.



### SMARTCARD HARDWIRED LOCK SYSTEM

Hardwired locks network together on standard computer networks. Hardwired solutions utilise the latest smartcard technology and are the only way to manage large locker installations.

## SEATING

Create a comfortable locker room environment with quality seating solutions, designed to enhance user experience and make the best use of your space. From ottoman style to bench seating, our range of functional and ergonomic designs can be positioned in a variety of perimeter and internal configurations, in both single and double-sided formats to best suit your purposes.

Designed for convenience, comfort and durability, Interloc seating combines the best in design and manufacturing with simple installation, making it easy for you to create the perfect locker area.



## OTTOMAN SEATING

The ottoman bench seat is carefully designed for optimum comfort and style. Combining the best of classic and contemporary design, these multi-purpose seating solutions are durable and easy to clean, making them a practical addition to any locker space.

Our ottomans are fully upholstered with a quality vinyl finish, and are available in a range of stylish colours to match and enhance any décor. Manufactured from quality, multi-density foam, they provide firm support for superior comfort and functionality.



## BEAM SEAT

For a more contemporary design, perfect for enhancing the décor of any locker space, the smart and stylish beam seat offers great comfort and functionality. Featuring a powder-coated steel beam, sturdy chrome legs, and a base fitted with a stylish perforated steel seat. Also features an ergonomic waterfall edge for safety and ease of use, and an optional vinyl clad, multi-density foam cushion offers enhanced comfort.





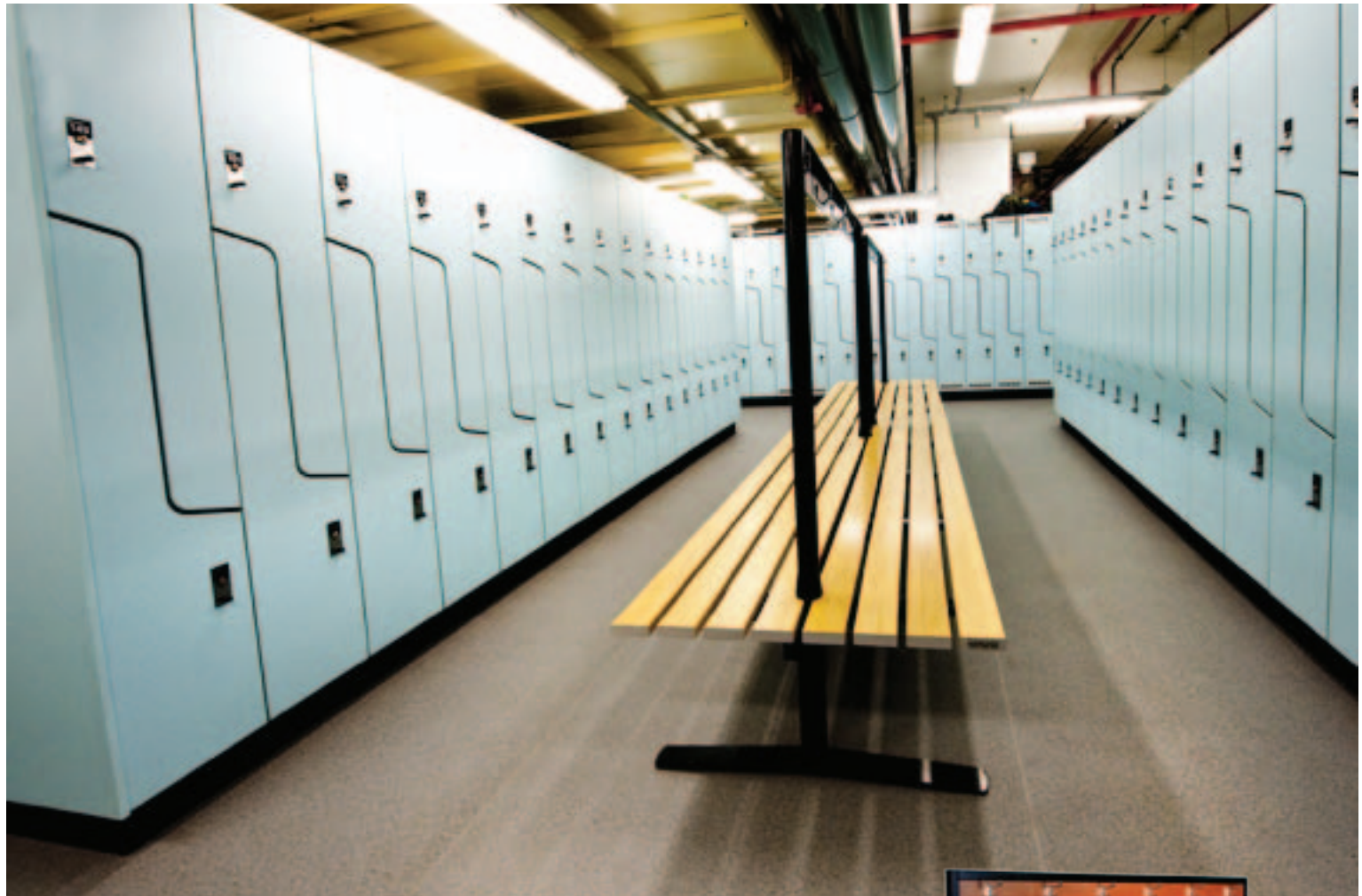

### **T LEG BENCH**

The simple and unobtrusive T-shaped leg design maximises leg and foot room for users, and allows for simple and convenient cleaning under and around the bench. With concealed fixings and neatly finished edging, it's a safe and functional solution. Available in a range of lengths and widths, and features recycled timber or Solid Victorian Ash slats and powdercoated leg framing.



### **STANDARD BENCH**

Our standard bench design is an attractive and functional solution suitable for a range of locker room environments. Available in a range of lengths and widths, the standard bench features recycled timber slats and powdercoated leg framing.



# Seating Specifications

## Seating Options

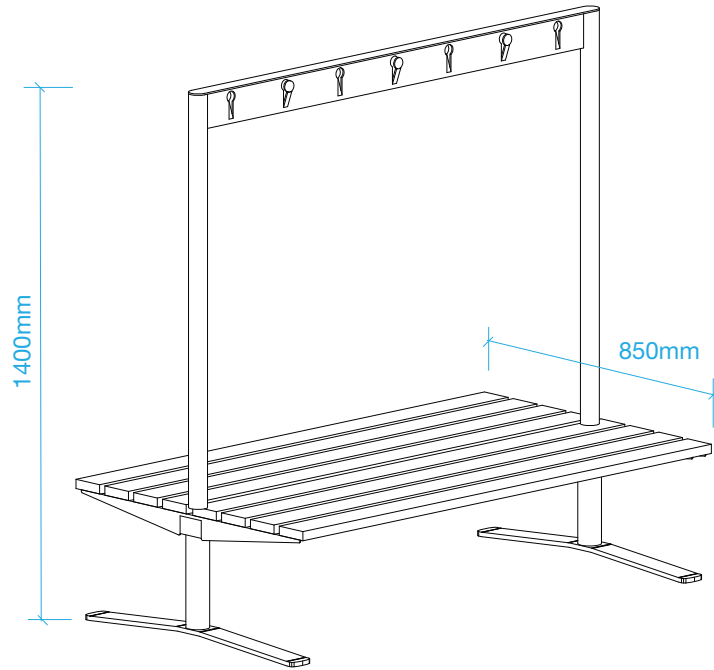
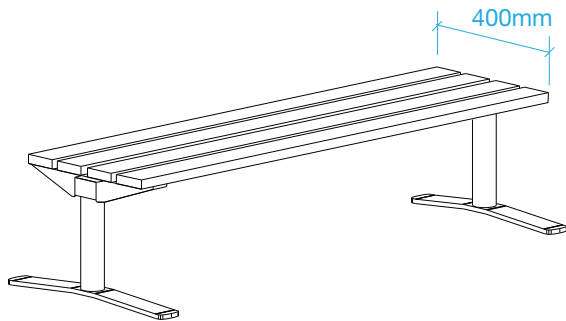

### Seating Lengths

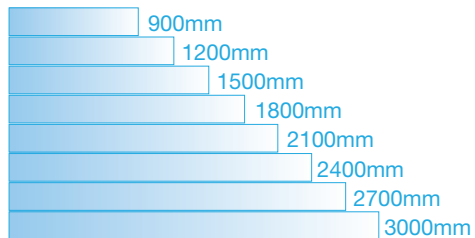

### Seating Lengths

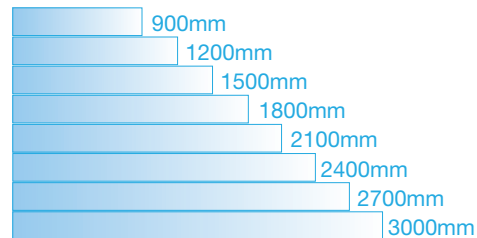



Experience the best in security, style and service. Interloc can provide you with sophisticated storage and seating solutions for any environment, tailored perfectly to your needs. Our innovative approach to design, manufacturing and installation ensures you always get the best quality, and our premium customer service means the whole process is hassle-free. For stylish, functional locker systems and seating, talk to Interloc today.

AUSTRALIAN OWNED • AUSTRALIAN MADE • AUSTRALIA WIDE



Interloc's Timber Laminate Lockers have met **Ecospecifier's Level A GREEN TAG™ GreenRate Certification** requirements which means customers can be assured they are supporting a trusted Australian company that is in line with environmental and social compliance.

To meet the GBCA's Green Star requirements, Ecospecifier has assessed Interloc against the following criteria: Toxicity, Product Durability, Product Emissions to include VOC's, Product Stewardship, Compliant Supply Chain, Legal Compliance, and Social Responsibility. In addition, Interloc Lockers are certified AS/NZS ISO 14001: 2004 Environmental Management System (EMS). For more on Ecospecifier's Level A GREEN TAG™ GreenRate and other social and environmental information visit [www.interloc.com.au](http://www.interloc.com.au)

**Interloc Lockers Pty Ltd**

ABN 53 103 876 455

Unit 32, 46 Wellington Rd,  
South Granville NSW 2142

Tollfree: 1300 INTERLOC

Email: [sales@interloc.com.au](mailto:sales@interloc.com.au)

[www.interloc.com.au](http://www.interloc.com.au)

