



Larnec Doors & Systems Catalogue

Manufacturers of quality timber & metal doors, pressed metal door frames for the commercial, industrial, garage, transportable & container building industries



Welcome to the Larnec Doors & Systems Catalogue

Larnec Doors & Systems welcomes you to our new catalogue for 2009.

As an established family owned leader in its industry, we combine 30 years of experience and passion with the highest quality and most competitively priced doors in the Australian market. Our doors are specifically made for long-lasting security solutions, whilst enhancing all entrance ways with class, sophistication and the necessary armoury to withstand Australia's toughest weather conditions.

To stay ahead of our competitors, we regularly review the latest trends and developing needs of all customers. We then integrate new products into our catalogue, ensuring Larnec Doors & Systems remains the most adaptive and alert company of its type in the market. Flexibility in service is what sets us apart from the rest.

It is on that note that the 2009 Larnec Doors & Systems catalogue is proud to present a complete and comprehensive range of products, including the newly developed Sentry™ 380 Cyclone rated doors and the revolutionary Sentry™ 400 Vandal proof doors.

Through Larnec's stringent endorsement of the CANI principles (Continuous and Never-ending Improvements) and enhanced by our reputable nation-wide networking capabilities, we pride ourselves on being:

Large enough to service. Small enough to care.

As a rapidly expanding company with an exciting future, Larnec wishes to extend our offer of quality service, value for money and a world class range of products as a unique business opportunity for all of our clients.

Philip Joyce
General Manager



Contents



Larnec Doors & Systems The industry leader

Sentry™

The Sentry™ Range of products

Sentry™ 100 Metal clad doors

Sentry™ 200 Metal clad doors

Sentry™ 200TP Metal clad doors

Sentry™ T200 Metal clad doors

Sentry™ 300 Bullet proof doors

Sentry™ 380 Cyclone rated doors

Sentry™ 400 Vandal proof doors

Sentry™ 500 Acoustic doors

Sentry™ 650 Metal doors

Sentry™ Fire doors

Sentry™ Timber doors & pressed metal door frames

Sentry™ Wall vents

Sentry™ Door colours

Larnec Doors & Systems Locks & accessories

Technical Data Sheets

Champion™ Stable Systems

Champion™ Stable Systems Range of products

Champion™ Stable Systems Doors & shutters

Champion™ Stable Systems Partitions

Customer Care

Larnec Doors & Systems Warehouse & packaging

Larnec Doors & Systems Warranty

Larnec Doors & Systems Customer care commitment

Larnec Doors & Systems Easy contact guide



Larnec Doors & Systems

The industry leader

- 1** Timber and metal doors are all we make. We are the specialists in metal and timber doors for the Commercial Industries, Industrial Industries, Container, Garage and Transportable Building.
- 2** We offer a comprehensive 24 month factory backed warranty.
- 3** We understand how important on-time delivery is to our industry and have instigated an exacting delivery system which we also guarantee.
- 4** We manufacture to all Government safety and building standards (Building code of Australia and Australian Standards).
- 5** We fully weld all our steel products for strength and safety.
- 6** We use the latest construction technology.
- 7** Maintenance free doors.
- 8** Time saving products for installation.
- 9** Full technical and problem solving support.
- 10** We use the best Australian made materials.
- 11** The Larnec Research & Development department is able to design and produce customised doors to any size or shape needed.
- 12** We comprehensively test and evaluate every door model before release into the market place.
- 13** We sell and distribute into every state of Australia, as well as New Zealand, Asia and the United Kingdom.
- 14** Larnec is 100% Australian owned and operated.
- 15** We have over 30 years experience of being suppliers to the building industry. We know the industry, its wants and desires.

We deliver Australia wide!



Sentry™

The Sentry™ Range of products

Sentry™ 100 Metal clad doors

Sentry™ 200 Metal clad doors

Sentry™ 200TP Metal clad doors

Sentry™ T200 Metal clad doors

Sentry™ 300 Bullet proof doors

Sentry™ 380 Cyclone rated doors

Sentry™ 400 Vandal proof doors

Sentry™ 500 Acoustic doors

Sentry™ 650 Metal doors

Sentry™ Fire doors

Sentry™ Timber doors & pressed metal door frames

Sentry™ Wall vents

Sentry™ Door colours

Larnec Doors & Systems Locks & accessories



The Sentry™ Range of products



The Sentry™ range of doors has been developed and engineered to be suitable for any application where a door is needed. We offer a range of doors that are suitable for a wide variety of uses. Every door in the Sentry™ range comes pre-hung in a frame for easy installation.

We have high security doors in the Sentry™ 100 range that have been used in high risk places such as banks, prisons and airports. The Sentry™ 200 range offers our clients a high to medium security door that provides ample security ratings for use in buildings such as factories, office buildings, shopping centers and transportable buildings, while our Sentry™ 650 range of doors are the number one choice in doors for any type of application in the garage or shed industry.

All our Sentry™ products come with a guaranteed 24 Month warranty ensuring all our clients know they are using a world class product, designed to save them time and money.

Benefits of The Sentry™ Door System

Features

- Pre-hung door
- Four sided frame
- Prepared for lock
- Supplied with lockset
- Pre finished materials, Colorbond® steel facing and powdercoated frame

Benefits

- Ease of installation
- Universal handing (choosing L/H or R/H on site)
- No drilling on site
- You have all you need (meets building codes)
- Maintenance free
- Durable long lasting and attractive

The Sentry™ Class Rating system

Throughout this catalogue we have utilised our standard Class Rating. This will give you a greater understanding of the type of industries and uses in which the Sentry™ range of doors can be used.

Class A High Security	Class B High to Medium Security	Class C Medium Security
Sentry™ 100, 300, 380	Sentry™ 200, 400, 500	Sentry™ 650
<ul style="list-style-type: none"> • Banks • Airports • Prisons • Some government buildings • Department stores • Pay offices 	<ul style="list-style-type: none"> • Precast / masonry buildings • Steel constructed buildings • Cool rooms • Remote housing • Plant-rooms • Transportable buildings 	<ul style="list-style-type: none"> • Domestic garages • Compressor sheds • Pump sheds • Farm sheds

Sentry™ 100

Metal clad doors



Sentry™ 100

Metal clad doors

The Sentry™ 100 range of doors, have been specifically designed and engineered for use in all types of building where security is paramount. These doors have been used in prisons, banks, hospitals, airports, and numerous other styles of buildings. They offer all users peace of mind knowing they have a door designed to meet their exact requirements.

Sentry™ 100 is a high security door ideal for commercial and industrial buildings of all types where a high level of security is essential.

Sentry™ 100 comprises of a solid core metal clad door, with 1.0mm steel facings, pre-hung into a frame of your choice, powdercoated to suit. Supplied with quality knob/lever exit set, latchguard and fitted with three industrial quality hinges.

- Standard Size – 2040 mm x 820 mm
- Other sizes and colours are available on request



Larnec Doors Guarantee

Sentry™ Doors were created to meet demand for a door that is durable, resilient and competitively priced

Australia's leading manufacturer for all your door solutions

Please call our toll-free number for more information
1800 657 536

Ideal for buildings requiring high and effective security



Sentry™ 100

Metal clad doors

Code	Description
100/47	Std 100 door and frame 2040 x 820
100/47W	100 door and frame 2040 x 920
100/47S	100 door and frame 2040 x up to 1100
100/47D	100 double door and frame 2040 x (820 + 820)
100/47DW	100 double door and frame 2040 x (920 + 920)
100/47DS	100 double door and frame 2040 x up to (1100 + 1100)



47

Code	Description
100/IN	Std 100 inward swinging door and frame 2040 x 820
100/INW	100 inward swinging door and frame 2040 x 920
100/INS	100 inward swinging door and frame 2040 x up to 1100
100/IND	100 inward double door and frame 2040 x (820 + 820)
100/INDW	100 inward double door and frame 2040 x (920 + 920)
100/INDS	100 inward double door and frame 2040 x up to (1100 + 1100)



IN

Code	Description
100/80	Std 100 door and frame 2040 x 820
100/80W	100 door and frame 2040 x 920
100/80S	100 door and frame 2040 x up to 1100
100/80D	100 double door and frame 2040 x (820 + 820)
100/80DW	100 double door and frame 2040 x (920 + 920)
100/80DS	100 double door and frame 2040 x up to (1100 + 1100)

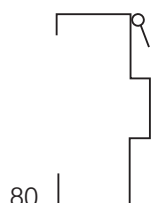

80

The Sentry™ 100 series doors can be manufactured to any size requirements you are after. The above charts show the codes required when ordering a Sentry™ 100 product.

W = Wide

S = Special – You nominate the size required

D = Double

DW = Double Wide

DS = Double Special - You nominate the size required

IN = Inward

**For more information please request fact sheet number:
100/47, 100/IN, 100/80**

How to specify

Doors shall be Sentry™ 100 doors. Comprising of a metal clad solid core door with 1.0mm steel facings. Pre-hung in a Sentry™ heavy duty powdercoated frame to be fitted with 3 industrial grade hinges and furniture as specified.

Available from Larnec Doors & Systems 1800 657 536

Areas of use

- CLASS A
- CLASS B

Options

- J-mould
- Air relief grilles
- Double doors
- Range of door furniture to suit including:
 - Power closers
 - Spring retainers
 - Panic bars
- Inward swinging
- Glazed windows – ½ lite, viewing panels etc.
- Custom sizes available
- Refer to Sentry™ Door colours for a full range of colour options
- Refer to Larnec Doors & Systems Locks & accessories for our full range

Sentry™ 200

Metal clad doors



Sentry™ 200

Metal clad doors

For any type of commercial and industrial application, the Sentry™ 200 is the ideal personal access door because of its versatility and strength.

Sentry™ 200 is the perfect door for commercial and industrial buildings of all types, for personal access areas and emergency exit doors.

Sentry™ 200 comprises of a semi solid metal clad door with Colorbond® steel facings, pre-hung into a choice of frame, powdercoated to suit. Supplied with quality knob/lever exit set and fitted with three industrial grade hinges, there are many options available, all made to commercial and industrial quality standards.

- Standard Size – 2040 x 820 mm
- Other sizes and colours are available on request



Larnec Doors Guarantee

Sentry™ Doors were created to meet demand for a door that is durable, resilient and competitively priced

Australia's leading manufacturer for all your door solutions

Please call our toll-free number for more information
1800 657 536

The perfect door for commercial and industrial buildings



Sentry™ 200

Metal clad doors

Code	Description
200/47	Std 200 door and frame 2040 x 820
200/47W	200 door and frame 2040 x 920
200/47S	200 door and frame 2040 x up to 1100
200/47D	200 double door and frame 2040 x (820 + 820)
200/47DW	200 double door and frame 2040 x (920 + 920)
200/47DS	200 double door and frame 2040 x up to (1100 + 1100)



Code	Description
200/IN	Std 200 inward swinging door and frame 2040 x 820
200/INW	200 inward swinging door and frame 2040 x 920
200/INS	200 inward swinging door and frame 2040 x up to 1100
200/IND	200 inward double door and frame 2040 x (820 + 820)
200/INDW	200 inward double door and frame 2040 x (920 + 920)
200/INDS	200 inward double door and frame 2040 x up to (1100 + 1100)



Code	Description
200/80	Std 200 door and frame 2040 x 820
200/80W	200 door and frame 2040 x 920
200/80S	200 door and frame 2040 x up to 1100
200/80D	200 double door and frame 2040 x (820 + 820)
200/80DW	200 double door and frame 2040 x (920 + 920)
200/80DS	200 double door and frame 2040 x up to (1100 + 1100)



The Sentry™ 200 series doors can be manufactured to any size requirements you are after. The above charts show the codes required when ordering a Sentry™ 200 product.

W = Wide

S = Special – You nominate the size required

D = Double

DW = Double Wide

DS = Double Special - You nominate the size required

IN = Inward

**For more information please request fact sheet number:
200/47, 200/IN, 200/80**

How to specify

Doors shall be Sentry™ 200 doors. Comprising of a metal clad door with Colorbond® steel facings. Pre-hung in a heavy duty metal frame with a powdercoated finish and fitted with three industrial grade hinges and door furniture as specified.

Available from Larnec Doors & Systems 1800 657 536

Areas of use

- CLASS B

Options

- J-mould
- Air relief grilles
- Double doors
- Range of door furniture to suit including:
 - Power closers
 - Spring retainers
 - Panic bars
- Inward swinging
- Glazed windows – ½ lite, viewing panels etc.
- Custom sizes available
- Refer to Sentry™ Door colours for a full range of colour options
- Refer to Larnec Doors & Systems Locks & accessories for our full range

Sentry™ 200TP

Metal clad doors



Sentry™ 200TP

Metal clad doors

The Sentry™ 200TP has been specifically designed and engineered to cater for the tilt panel and masonry market. It has been purposely built to provide the client with the most cost effective way to fit a door to any concrete tilt panel building, masonry and coolroom panel walls, giving a clean and professional finish.

Sentry™ 200TP is the perfect door for concrete panel, masonry and coolroom panel walls. The two piece frame creates its own flashing inside and out, with the benefit of no unsightly concrete or brick corners. With the Dualquad™ fastening system there are no external fasteners. This, plus the added advantage of being able to suit any wall thickness, is why this door is used by some of the most respected companies in the industry.

Sentry™ 200TP comprises of a semi solid metal clad door with Colorbond® steel facings, pre-hung into a two piece frame. Furthermore, the Dualquad™ fastening system is supplied with a quality knob/lever exit set and fitted with three Industrial grade hinges.

- Standard Size – 2040 x 820 mm
- Other sizes and colours are available on request

Ideal for concrete panel, masonry and coolroom panel walls



Larnec Doors Guarantee

Sentry™ Doors were created to meet demand for a door that is durable, resilient and competitively priced

Australia's leading manufacturer for all your door solutions

Please call our toll-free number for more information
1800 657 536



Sentry™ 200TP

Metal clad doors

Code	Description (X = wall thickness)
200TP	Std 200 door and TP frame 2040 x 820
200TPW	200 door and TP frame 2040 x 920
200TPS	200 door and TP frame 2040 x up to 1100
200TPD	200 double door and TP frame 2040 x (820 + 820)
200TPDW	200 double door and TP frame 2040 x (920 + 920)
200TPDS	200 double door and TP frame 2040 x up to (1100 + 1100)

Code	Description
200TPIN	200 inward swinging door and TP frame 2040 x 820
200INW	200 inward swinging door and TP frame 2040 x 920
200TPINS	200 inward swinging door and TP frame 2040 x up to 1100
200TPIND	200 inward double door and TP frame 2040 x (820 + 820)
200TPINDW	200 inward double door and TP frame 2040 x (920 + 920)
200TPINDS	200 inward double door and TP frame 2040 x up to (1100 + 1100)

The Sentry™ 200TP series doors can be manufactured to any size requirements you are after. The above charts show the codes required when ordering a Sentry™ 200TP product.

W = Wide

S = Special – You nominate the size required

D = Double

DW = Double Wide

DS = Double Special –

You nominate the size required

IN = Inward

For more information please request fact sheet number: 200TP or 200TPIN

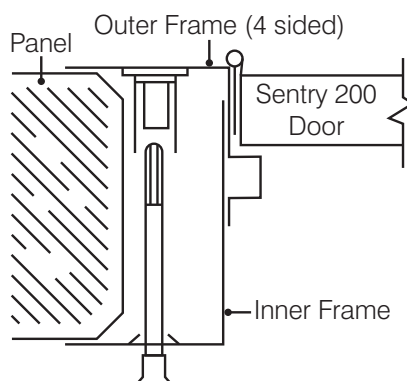
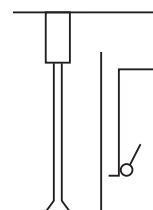
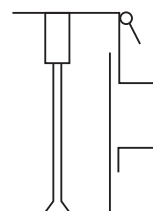

How to specify

Doors shall be Sentry™ 200TP doors comprising of a metal clad door with Colorbond® steel facings. Pre-hung into Sentry's™ unique two-piece metal frame, incorporating the Dualquad™ fastening system, with a powdercoated finish. Three industrial grade hinges to be fitted and door furniture as specified.

Available from Larnec Doors & Systems 1800 657 536

Areas of use

- CLASS B

Options

- Air relief grilles
- Double doors
- Range of door furniture to suit, including:
 - Power closers
 - Spring retainers
 - Panic bars
- Inward swinging
- Glazed windows – ½ lite, viewing panels etc.
- Custom sizes available
- Refer to Sentry™ Door colours for a full range of colour options
- Refer to Larnec Doors & Systems Locks & accessories for our full range

Sentry™ T200

Metal clad doors



Sentry™ T200

Metal clad doors

The Sentry™ T200 has been designed and engineered in association with some of Australia's leading transport companies. This door has been specifically manufactured to meet the strenuous demands that are required of products in the Transportable building industry.

Sentry™ T200 is the perfect door for transportable buildings, eg: site offices, lunch rooms, first aid centres and sleeping quarters just to mention a few.

Sentry™ T200 comprises of a semi-solid metal clad door with Colorbond® steel facings, pre-hung into a frame of your choice, powdercoated to suit. Fitted with seals to counter the most violent dust storms and unfavorable weather, the doors are also supplied with a quality knob/lever exit set and three industrial grade hinges.

- Standard Size – 2040 x 820 mm
- Custom door sizes and colours are available on request



Larnec Doors Guarantee

Sentry™ Doors were created to meet demand for a door that is durable, resilient and competitively priced

Australia's leading manufacturer for all your door solutions

Please call our toll-free number for more information
1800 657 536

Ideal for transportable and temporary accommodation buildings



Sentry™ T200

Metal clad doors

Code	Description
T200/76	Std T200 door and frame 2040 x 820
T200/76W	T200 door and frame 2040 x 920
T200/76S	T200 door and frame 2040 x up to 1100
T200/76D	T200 double door and frame 2040 x (820 + 820)

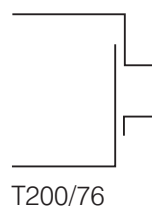

Code	Description
T200/IN	Std T200 inward swinging door and frame 2040 x 820
T200/INW	T200 inward swinging door and frame 2040 x 920
T200/INS	T200 inward swinging door and frame 2040 x up to 1100
T200/IND	T200 inward double door and frame 2040 x (820 + 820)

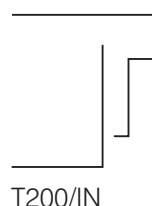

Code	Description
T200/50	Std T200 door and frame 2040 x 820
T200/50W	T200 door and frame 2040 x 920
T200/50S	T200 door and frame 2040 x up to 1100
T200/50D	T200 double door and frame 2040 x (820 + 820)

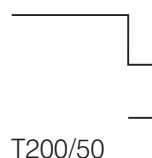

Code	Description
T200/IN50	Std T200 door and frame 2040 x 820
T200/IN50W	T200 door and frame 2040 x 920
T200/IN50S	T200 door and frame 2040 x up to 1100
T200/IN50D	T200 double door and frame 2040 x (820 + 820)



The Sentry™ T200 series doors can be manufactured to any size requirements you are after. The above charts show the codes required when ordering a Sentry™ T200 product.

W = Wide
S = Special – You nominate the size required
D = Double

DW = Double Wide
DS = Double Special – You nominate the size required
IN = Inward

**For more information please request fact sheet number:
T200 or T200IN**

How to specify

Doors shall be Sentry™ T200 doors comprising of a metal clad door with Colorbond® steel facings. Pre-hung in a powdercoated frame fitted with seals, three industrial quality hinges and door furniture as specified.

Available from Larnec Doors & Systems 1800 657 536

Areas of use

- CLASS B

Options

- J-mould
- Air relief grilles
- Double doors
- Range of door furniture to suit including:
 - Power closers
 - Spring retainers
 - Panic bars
- Inward swinging
- Glazed windows – ½ lite, viewing panels etc.
- Custom sizes available
- Refer to Sentry™ Door colours for a full range of colour options
- Refer to Larnec Doors & Systems Locks & accessories for our full range
- Security screen doors
- Crimsafe screen doors

Sentry™ 300

Bullet proof doors



Sentry™ 300

Bullet proof doors

Today more than ever, analysing the risk of attack is essential for every building. It means providing a level of protection relevant to the security risk. Special thought needs to be given to the type of door used in these situations. All buildings that deal with large amounts of cash or valuables, need to protect themselves and their staff from intruders.

Sentry™ 300 is a high security, bullet proof door ideal for commercial and industrial buildings of all types where a high level of security is essential.

Sentry™ 300 is specifically designed and engineered to provide the highest protection against all forms of attack. The Sentry™ 300 comes in two sizes as listed below.

- Standard size – 2040 x 870 mm
- Special size – 2040 x 970 mm



Larnec Doors Guarantee

Sentry™ Doors were created to meet demand for a door that is durable, resilient and competitively priced

Australia's leading manufacturer for all your door solutions

Please call our toll-free number for more information
1800 657 536

For all buildings where security is paramount



Sentry™ 300

Bullet proof doors

Code	Description
300/ST	300 door and frame 2040 x 870
300/SP	300 door and frame 2040 x 970

Steel is the material that offers optimal protection against violent attacks. The doors in the Sentry™ 300 range have taken this into account. Each door has been designed to withstand not only blasts from a bullet but also from the use of jimmy bars, as well as power tools. All doors in the range come standard with 3 locking points. The doors are also fitted with hinge bolts to prevent the doors being ripped out, even if the hinges were tampered with. The three ball bearing hinges used are heavy duty and are used for strength and to allow easy opening and closing by authorised users. All of the reinforcements are concealed within the door so as to maintain the aesthetics.

For more information please request fact sheet number: 300-ST or 300/SP

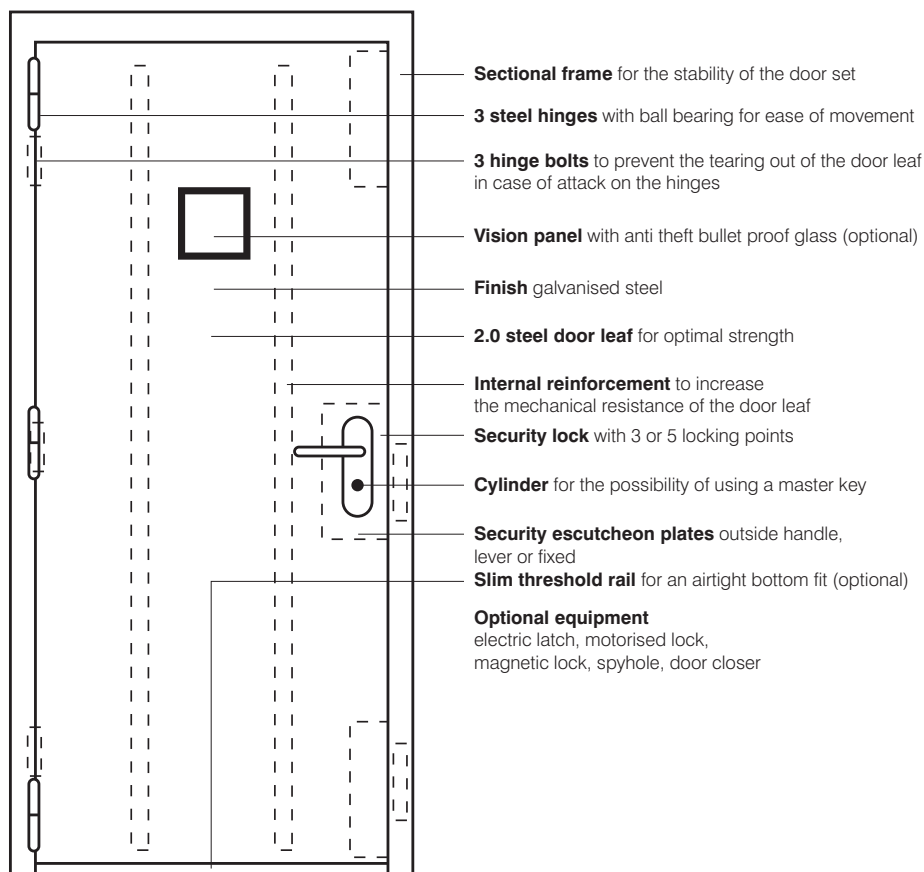

How to specify

Doors shall be Sentry™ 300 doors. Comprising of a metal clad solid core door with steel facings. Pre-hung in a Sentry™ heavy duty powdercoated frame to be fitted with 3 industrial grade hinges and furniture as specified.

Available from Larnec Doors & Systems 1800 657 536

Areas of use

- CLASS A
- CLASS B

Options

Contact your local representative for more information



Impact on shooting side

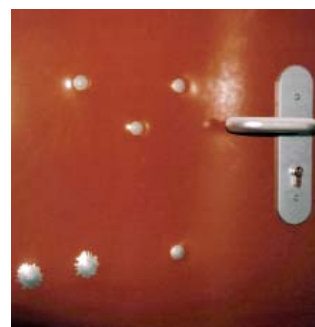

Impact on inside of door

Sentry™ 300

Bullet proof doors

A completely steel construction

Steel is the material that offers optimal protection against violent attacks. Door sets of the 400 range have a leaf in thick steel with reinforcements. The sectional frame and welded hinges are designed for extra strength. Hinge bolts prevent tearing out the door leaf even if the hinges have been severed.

All reinforcements are located inside the door set to maintain aesthetics and discretion. Ball bearing hinges allow easy opening and closing.

A high security multipoint locking system

A crucial point of security, the 400 range lock provides top efficiency due to 3 or 5 deadbolts spread around the opening. The central lock case is protected by the steel escutcheon plate to prevent forced opening. Unique to our 400 range, high security escutcheon plates, made of hardened steel with an exclusive fixing system, provide an almost invulnerable protection of the lock and cylinder.

Clear vision for security

In sensitive areas, any caller outside must be identified prior to opening. A spyhole allows 200 degrees of vision from inside, in total discretion.

In more busy premises, a rectangular or circular glass vision panel provides light and a welcoming atmosphere. Anti burglary resistance is maintained through laminated bullet-proof glass and solid steel beads.



Hinge & hingebolt



Extra strength security door handle



Vision panel



Spyhole

Sentry™ 380

Cyclone rated doors



Sentry™ 380

Cyclone rated doors

As Australia continues to grow as a nation, we are starting to develop communities in what were once considered remote parts of the country, as well as parts of our coastlines that are renowned for adverse and cyclonic weather conditions. It is due to these adverse conditions that Larnec Doors & Systems has invested a great deal of time and money into our new Sentry™ 380 series range of cyclonic doors. The doors in this range have been engineered to a standard never before seen in the Australian door market. The doors comply with AS1170.2.

All Sentry™ 380 doors come with a cyclone rated certificate and each door is tagged for your peace of mind.

Sentry™ 380 is a high security door that has been specifically designed to protect all forms of buildings against cyclones.

Each cyclonic door is tagged and certified when installed. Maintenance and inspection contracts can be provided and a registered log book provided to maintain years of carefree service.



Larnec Doors Guarantee

Sentry™ Doors were created to meet demand for a door that is durable, resilient and competitively priced

Australia's leading manufacturer for all your door solutions

Please call our toll-free number for more information
1800 657 536

For all buildings in cyclone prone areas



Sentry™ 380

Cyclone rated doors

Code	Description
380/47	Std 200 door and frame 2040 x 820
380/47W	200 door and frame 2040 x 920
380/47S	200 door and frame 2040 x up to 1100
380/47D	200 double door and frame 2040 x (820 + 820)
380/47DW	200 double door and frame 2040 x (920 + 920)
380/47DS	200 double door and frame 2040 x up to (1100 + 1100)



Code	Description
380/IN	Std 200 inward swinging door and frame 2040 x 820
380/INW	200 inward swinging door and frame 2040 x 920
380/INS	200 inward swinging door and frame 2040 x up to 1100
380/IND	200 inward double door and frame 2040 x (820 + 820)
380/INDW	200 inward double door and frame 2040 x (920 + 920)
380/INDS	200 inward double door and frame 2040 x up to (1100 + 1100)



Code	Description
380/80	Std 200 door and frame 2040 x 820
380/80W	200 door and frame 2040 x 920
380/80S	200 door and frame 2040 x up to 1100
380/80D	200 double door and frame 2040 x (820 + 820)
380/80DW	200 double door and frame 2040 x (920 + 920)
380/80DS	200 double door and frame 2040 x up to (1100 + 1100)



The Sentry™ 380 series doors can be manufactured to any size requirements you are after. The above charts show the codes required when ordering a Sentry™ 380 product. All doors are tagged and certified.

W = Wide

S = Special – You nominate the size required

D = Double

DW = Double Wide

DS = Double Special - You nominate the size required

IN = Inward

For more information please request fact sheet number:

380

How to specify

Doors shall be Sentry™ 380 doors. Comprising of a metal clad door with Colorbond® steel facings. Pre-hung in a heavy duty metal frame with a powdercoated finish and fitted with three industrial grade hinges and door furniture as specified.

Available from Larnec Doors & Systems 1800 657 536

Areas of use

- CLASS B

Options

- J-mould
- Air relief grilles
- Double doors
- Range of door furniture to suit including:
 - Power closers
 - Spring retainers
 - Panic bars
- Inward swinging
- Glazed windows – ½ lite, viewing panels etc.
- Custom sizes available
- Refer to Sentry™ Door colours for a full range of colour options
- Refer to Larnec Doors & Systems Locks & accessories for our full range
- Security screen doors
- Crimsafe screen doors

Sentry™ 400

Vandal proof doors



Sentry™ 400

Vandal proof doors

The Sentry™ 400 range of doors has been designed to specifically cater for public areas where a high level of security is required. These doors have been engineered in a way to provide you with a high resistance to damage, thus greatly reducing your maintenance and replacement costs. All parts of the door, from the leaf to the frame and locks, have been specifically engineered to provide maximum resistance to attacks from lighters, knives and most forms of physical attack.

Sentry™ 400 is a high security door ideal for commercial and industrial buildings of all types where a high level of security is essential.

Sentry™ 400 comprises of two steel skins strengthened by internal reinforcements that offer excellent stability over time. As the door hinges are often a point of attack, the Sentry™ 400 range hinges are hung on two pivots that are invisible and unreachable to users.

- Standard size – 2040 x 870 mm
- Special Size – 2040 x 1020 mm

For all buildings where security and anti-vandalism is paramount



Larnec Doors Guarantee

Sentry™ Doors were created to meet demand for a door that is durable, resilient and competitively priced

Australia's leading manufacturer for all your door solutions

Please call our toll-free number for more information
1800 657 536

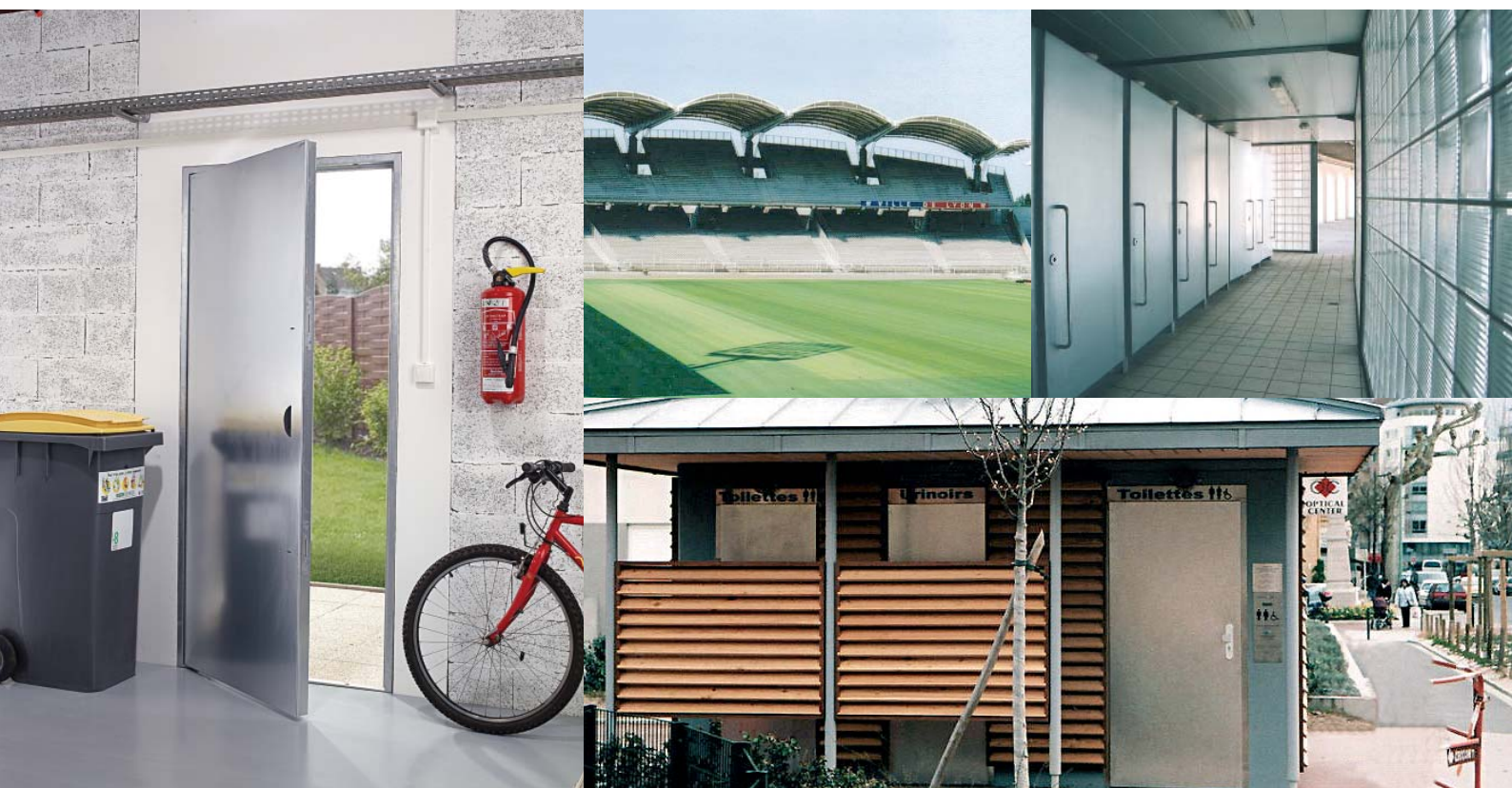

Sentry™ 400

Vandal proof doors

Code	Description
400/ST	400 door and frame 2040 x 870
400/SP	400 door and frame 2040 x 1020

The Sentry™ 400 series of doors is intended to suit all types of public and collective premises. It is designed to ensure user safety, with pivot opening to prevent fingers being pinched. A flexible rubber seal fixed on the leaf absorbs the force of closing and prevents any risk of injury, particularly when the doors are roughly handled, or being used by children and the elderly. The Sentry™ 400 locks, bolts and handles are designed to withstand attack.

**For more information please request fact sheet number:
400-ST or 400/SP**

The metal anti-vandalism door set: what are the characteristics?

All communication and access doors in public and collective places are subjected to intensive use by careless and sometimes spiteful users. Due to this, such doors must be designed for lasting resistance to damage, in order to avoid high maintenance or replacement costs. All parts of the door such as the leaf, frame and locking devices must be resistant against instruments such as penknives and cigarette lighters, as well as physical attacks. Steel is the ideal material to offer this resistance. Furthermore, it is an eco-friendly material, being easily recyclable.

How to specify

Doors shall be Sentry™ 400 doors. Comprising of a metal clad solid core door with Colorbond® steel facings. Pre-hung in a Sentry™ heavy duty powdercoated frame to be fitted with 3 industrial grade hinges and furniture as specified.

Available from Larnec Doors & Systems 1800 657 536

Areas of use

- CLASS A
- CLASS B

Options

Contact your local representative for more information

Sentry™ 400

Vandal proof doors

A high level of strength

The Vandal proof door set is entirely metal. It contains an extremely rigid tubular frame which guarantees its strength in extreme conditions. The leaf is made of two steel skins strengthened by internal reinforcements and offers excellent stability over a long period of time, even when subjected to bad weather or intensive use. As the door hinges are often a point of attack, Vandal proof door sets are hung on two pivots that are invisible and unreachable to users.

A high level of ergonomics

The Sentry™ 400 door set is intended to suit all types of public and collective premises. It is designed to ensure user safety with pivot opening to prevent fingers being pinched. A flexible rubber seal fixed on the leaf absorbs the force of closing and avoids risk of injury, particularly when the doors are roughly handled or used by children and elderly people.

Anti-damage solutions

Controlling access is an essential function of doors and demands the use of strong bolting systems. The Larnec locks, bolts and handles are designed to withstand attack and ensure user safety. Further options such as electric latches or magnetic locks enable controlled access without the inconvenience of multiple keys.

Larnec 2 year warranty

Larnec offers a 2 year warranty on the structure of the door sets and seals in normal conditions of use.



Top pivot



Handle



Security deadbolt

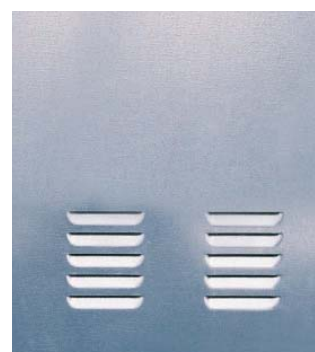

Vent holes

Sentry™ 400

Vandal proof doors

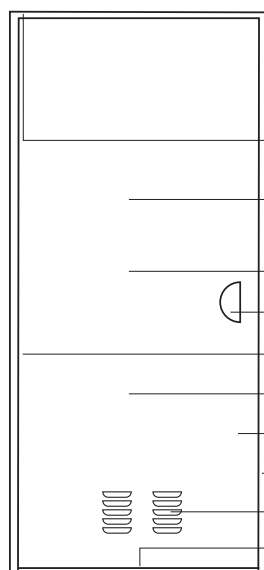

Sentry 400 door set

- Top and bottom pivots with ball bearings
- Steel sheet thickness 2.0mm for high impact resistance
- Internal reinforcements
- Vandalus handle
- Anti-pinch profile
- Galvanised steel or stainless steel finish
- Security deadlock
- Sectional frame
- Vent holes
- Slim threshold rail (no underfloor space required for bottom pivot)

Maximum size available

- Width 1350 x height 2600mm

Other available equipment

- 3 point lock
- Lever handles or pull handles
- Electric latch
- Magnet lock
- Panic bar
- Door closer

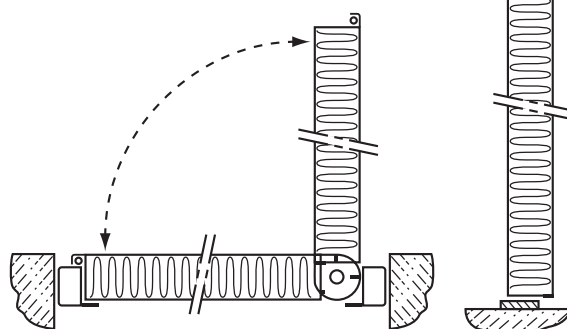

Flats

- Communal areas
- Plant rooms
- Rubbish bin storage areas

Stadiums

- Public toilets
- Public visiting areas

Service areas for travelling people

- Toilets
- Showers
- Plant rooms

Public places

- Public toilets
- Motorway service areas



Sentry™ 500

Acoustic doors



Sentry™ 500

Acoustic doors

Larnec Doors & Systems manufacturing facility can manufacture acoustic doors to any acoustic rating required. All of our acoustic doors are made to the client's specification. Our range of acoustic doors can be made to any size required, be it in single or doubles.

Acoustic doors are available in either timber or pressed metal. You have the choice of having them pre hung in either timber or metal frames as well as the option of having fire rated acoustic doors and frame sets.

For more information on this style of product please contact your local representative for further information.



Larnec Doors Guarantee

Sentry™ Doors were created to meet demand for a door that is durable, resilient and competitively priced

Australia's leading manufacturer for all your door solutions

Please call our toll-free number for more information
1800 657 536

The perfect solution for all acoustic applications



Sentry™ 500

Acoustic doors

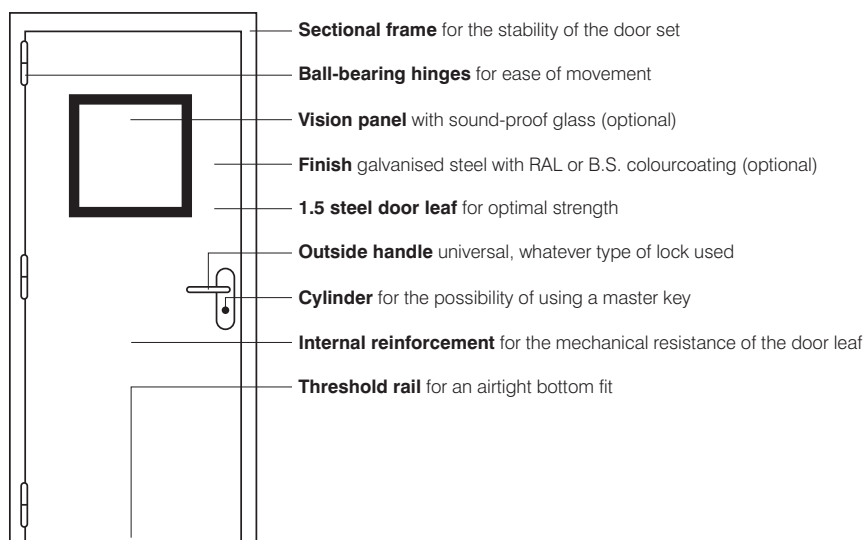

Limiting spread of noise

Being exposed to noise pollution creates great discomfort or even aggression, generating tiredness, stress and risk of partial or total deafness.

Larnec's insulation of buildings answers the requirements of comfort and functionality by preventing the propagation of aerial noises through partitions.

The areas of application are numerous, enabling the improvements of work conditions, the protection of relations with neighbours, or ensuring good acoustics in public places.

Resistance to bad weather

External doors are exposed to the brunt of various climatic conditions: rain, wind, and ultraviolet rays. Choosing steel as a base material offers all needed protection over time thanks to its mechanical resistance and incombustibility.

Internal insulation and rubber seals offer optimal comfort in all temperatures.

Providing emergency escape and security

The security of people and goods is the starting point when designing buildings. Instant opening fire exits have to be combined with the need of protecting premises against burglary. Steel doors equipped with locks and hardware in compliance with fire standards and regulations, answer to these requirements.

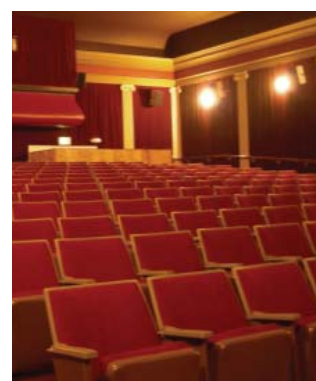

Sentry™ 500

Acoustic doors

Respecting the environment

Choosing steel means users are taking part in preserving the environment courtesy of its favorable ecological qualities of an almost unlimited life cycle, and cost effective ease with which the material is recycled.

Cost savings, thanks to increased thermal insulation, together with lower costs of maintenance, further enhance the ecological sustainability of steel.

A high level of strength

The Sentry™ 500 door set provides the highest standard for mechanical resistance, with an exclusive Larnec sectional frame, 1.5mm thick steel skins and steel hinges with ball bearings to guarantee the door set will stand the test of time against intensive use.

A high level of ergonomics

The Sentry™ 500 design enables comfortable use in public circulation, with no sharp edges on the leaf and all seats securely fixed. It is also valued for its clean styling with no apparent welding points.

A high level of performance

The Sentry™ 500 door set is the result of Larnec's know-how from over 15 years experience, with rubber seals fabricated exclusively for Larnec. The profile of these seals and their soft structure avoid the risk of leaks, even in the case of imperfect levels.

Choices for acoustic performance

When fixing doors in noisy environments, the Sentry™ 500 insulation requires the use of appropriate locking systems. Therefore, Sentry™ 500 door sets can take either the 3 point lock that ensures the compression of the seals as soon as the door is closed, or alternatively, progressive tightening locks which, with reduced manoeuvre, ensures perfect position of the door leaf.

Choices for safety

In conjunction with acoustic requirements, it is imperative that emergency exit regulations are adhered to. Sentry™ 500 door sets are available with single or triple locking point panic bars, to which electric locks servo-controlled by fire detection can be added.

Choices for conviviality

Valuable natural light can be taken advantage of with a vision panel to improve the atmosphere of premises without hindering acoustic comfort. In highly frequented places, this also means the passage of people can be monitored to facilitate safety.

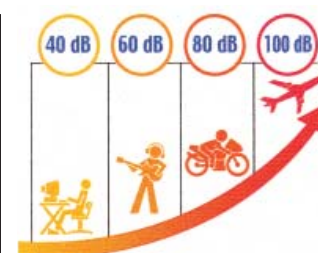

Sentry™ 650

Metal doors



Sentry™ 650 Metal doors

We supply the most practical and cost effective personal access door for all garage solutions in Australia.

Sentry™ 650 is the perfect personal access door for garages and sheds. Easy installation and universal handing as well as being:

- Easier, safer and smarter to use & install

This is why it is used by some of the most respected companies in the industry.

Sentry™ 650 comprises of a single skin metal clad door with Colorbond® steel facings and fold-down vertical sides for strength and appearance. On a welded RHS frame, the door is pre-hung into a choice of frame and powdercoated to suit.

- Supplied with a knob/knob entrance set
- Standard size – 2040 mm x 820 mm
- Custom door sizes and colours are available on request



Larnec Doors Guarantee

Sentry™ Doors were created to meet demand for a door that is durable, resilient and competitively priced

Australia's leading manufacturer for all your door solutions

Please call our toll-free number for more information
1800 657 536

Ideal for garages, all farm sheds and other external buildings



Sentry™ 650

Metal doors

Code	Description
650/61	Std 650 door and frame 2040 x 820
650/61W	650 door and frame 2040 x 1150

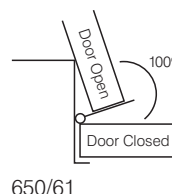

Code	Description
650/37	650 door and 37mm frame 2040 x 820
650/37W	650 door and frame 2040 x 1150 wide
650/37S	650 door and frame special width 2040 x up to 1150
650/37D	650 double door 2040 x (820 + 820)
650/37DW	650 double door 2040 x (1150 + 1150)
650/37DS	650 double door special width 2040 x up to (1150 + 1150)

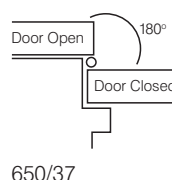

Benefits of the 650/37: 180 degree opening, silicone skinned door

Code	Description
650/IN	650 inward swinging door 2040 x 820
650/INW	650 inward swinging door 2040 x 1150
650/INS	650 inward special width up to 1150
650/IND	650 inward double 2040 x (820 + 820)
650/INDW	650 inward double 2040 x (1150 + 1150)
650/INDS	650 inward double special width up to (1150 + 1150)

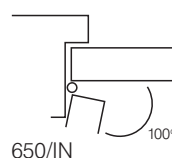

The Sentry™ 650 series doors can be manufactured to any size requirements you are after. The above charts show the codes required when ordering a Sentry™ 650 product.

W = Wide

S = Special – You nominate the size required

D = Double

DW = Double Wide

DS = Double Special - You nominate the size required

IN = Inward

**For more information please request fact sheet number:
650/61, 650/37, 650/IN**

How to specify

Doors shall be Sentry™ 650 doors. Comprising of a RHS frame, external clad with a Colorbond® steel facing folded on vertical sides. Pre-hung into a Sentry™ heavy duty powdercoated frame to be fitted with two industrial grade hinges and entrance set as specified.

Available from Larnec Doors & Systems 1800 657 536

Areas of use

- CLASS C

Options

- J-Flashing
- Double doors
- Inward swinging
- Range of door furniture to suit
- Custom sizes available
- Refer to Sentry™ Door colours for a full range of colour options
- Refer to Larnec Doors & Systems Locks & accessories for our full range

Sentry™

Fire doors



Sentry™ Fire doors

At Larnec Doors & Systems we have developed a quality fire rated door set that is complete with door furniture to meet all Australian standards required in this industry. We can talk you through all your requirements from planning through to supply and certification. We can even do your maintenance and yearly or 6 monthly safety checks.

Sentry™ Fire rated doors are the perfect door whenever a fire rating is required.
Eg: --/120/30 Two hour fire rated or --/240/30 Four hour fire rated.
Sentry™ Fire rated doors – come either metal clad or timber.

Sentry™ Fire rated door sets comprise of either a timber fire rated door or a metal clad fire rated door, pre hung into a fire rated pressed metal door frame, which also has the option of being powdercoated. All fire doors are supplied with a quality fire rated knob lever exit set and a door closer, or as per any specifications required.

Double doors are also supplied with a quality fire rated knob lever exit set, 2 x closer, 2 x panic bolts, sequence selector and aluminum meeting stiles. Handing is required for all Sentry™ Fire rated door sets. All fire door sets come complete with Fire door tags and certificates. Call to discuss your maintenance and safety check contracts.



Larnec Doors Guarantee

Sentry™ Doors were created to meet demand for a door that is durable, resilient and competitively priced

Australia's leading manufacturer for all your door solutions

Please call our toll-free number for more information
1800 657 536

The perfect door to be specified whenever a fire rating is required



Sentry™

Fire doors

Code	Description
FRMS	2040 x 820 metal clad fire door set
FRMS-W	2040 x 920 metal clad fire door set
FRMS-S	2040 x up to 1100 metal clad fire door set
FRMS-D	2040 x 820 + 820 metal clad fire door set
FRMS-DW	2040 x 920 + 920 metal clad fire door set
FRMS-DS	2040 x up to 1100 + 1100 metal clad fire door set

Code	Description
FRTS	2040 x 820 metal clad fire door set
FRTS-W	2040 x 920 metal clad fire door set
FRTS-S	2040 x up to 1100 metal clad fire door set
FRTS-D	2040 x 820 + 820 metal clad fire door set
FRTS-DW	2040 x 920 + 920 metal clad fire door set
FRTS-DS	2040 x up to 1100 + 1100 metal clad fire door set

The Sentry™ Fire door series doors can be manufactured to any size requirements you are after. The above charts show the codes required when ordering a Sentry™ Fire door product.

W = Wide

S = Special – You nominate the size required

D = Double

DW = Double Wide

DS = Double Special - You nominate the size required

IN = Inward

If you require any further information or specifications on any option please call one of our consultants

How to Specify

Doors shall be Sentry™ Fire doors comprising either timber or metal clad door with Colorbond® steel facings. Pre hung in a fire rated pressed metal frame with the option of a powdercoated finish, fitted with three industrial hinges and door furniture as specified.

Available from Larnec Doors & Systems 1800 657 536

Area of Use

- CLASS A
- CLASS B

Options

- Air relief grilles
- Double doors
- Range of door furniture to suit including:
 - Power closers
 - Spring retainers
 - Panic bars
- Glazed windows, viewing panels etc.
- Fire door log books
- Fire door inspections can be arranged under contract
- Custom sizes available
- Refer to Sentry™ Door colours for a full range of colour options
- Refer to Larnec Doors & Systems Locks & accessories for our full range

Sentry™

Timber doors &
pressed metal door frames



Sentry™

Timber doors & pressed metal door frames

Larnec Doors & Systems manufacturing plant can manufacture a timber door of any size for any application required. We also manufacture pressed metal door frames. Similarly our metal workshop has the capacity to make pressed metal door frames to suit any size required.

Larnec Doors & Systems manufacture and supply quality timber doors for the Commercial and Industrial Building Industries. Because of our manufacturing and supply technology, we can produce any type of timber door, from flush panel doors through to joinery doors, hollow core to solid core, veneer faces to MDF faces, fire rated doors and frames. We specialise in any standard or custom type pressed metal door frame for the building industry. Just ask our friendly staff about your requests.

- Solid and hollow core doors
- Pressed metal door frames – standard
- Fire rated doors and frames
- Pressed metal door frames – custom
- Acoustic doors and frames

The commercial and industrial applications are limitless



Larnec Doors Guarantee

Sentry™ Doors were created to meet demand for a door that is durable, resilient and competitively priced

Australia's leading manufacturer for all your door solutions

Please call our toll-free number for more information
1800 657 536



Sentry™

Timber doors & pressed metal door frames

Code	Description
HC	Hollow Core Door
SEMI	Semi Solid Door
SOLID	Solid Core Door

Hollow Core & Semi Solid Doors

Larnec Hollow Core Doors can also be referred to as flush panel doors. They can be used in both internal and external applications.

These doors incorporate a cellular cardboard infill which keeps the weight to a minimum.

The doors can be configured to many specifications:

- Core materials
- Frame
- Facings
- Sizes
- Thickness

Solid Core Doors

Larnec Solid Core Doors can be used in all internal and external environments. Where security is needed, these doors will perform reliably in all situations. These doors are used currently in all types of commercial and industrial buildings.

The doors can be configured to any specifications:

- Core materials
- Frame
- Facings
- Sizes
- Thickness

All Larnec's doors are manufactured to AS 2688-1984

Pressed Metal Door Frames

Larnec offers its customers a full range of pressed metal door frame products.

Products include frames suitable for dry wall, timber, metal and masonry walls.

We have standard and custom made frames designed for high frequency door openings that can come in welded or knockdown form.

Larnec's frames can be found in all types of industrial and commercial applications giving the customer flexibility and security.

Call your area manager to receive the full pressed metal door frame catalogue.

How to specify

Contact your local representative.

Available from Larnec Doors & Systems 1800 657 536

Areas of use

- CLASS A
- CLASS B

Options

- Timber door frames
- Air relief grilles
- Double doors
- Glazed windows – ½ lite, viewing panels etc.
- Custom sizes available
- Refer to Larnec Doors & Systems Locks & accessories for our full range

Sentry™

Wall vents



Sentry™ Wall vents

Larnec Doors & Systems also manufacture wall vents or louvers. We have 5 standard sizes in our range; however, we can cater to any size. Simply talk to your local representative.

Larnec Freeflow Louvres™ with their attractive modern profiles, will enhance the appearance of any building, or be incorporated as a design feature while providing optimum ventilation efficiency and screening requirements. Louvre sizes available are up to 3600 mm long by any height, in module panels and are fabricated in either aluminium or Colorbond®.

The louvres are installed in commercial, industrial and garage buildings for ventilation control, screening and storm proofing eg. air-conditioning intakes or exhausts, plant and equipment rooms, chemical sheds, sub stations, cooling towers, windows, gable end of sheds and horse stables.

Louvres can be installed in concrete, brickwork or steel frame constructions.



Larnec Doors Guarantee

Sentry™ Doors were created to meet demand for a door that is durable, resilient and competitively priced

Australia's leading manufacturer for all your door solutions

Please call our toll-free number for more information
1800 657 536

We supply vents to suit all commercial and residential applications



Sentry™

Wall vents

Sentry™ Fixed Wall Vents

Code	Description (wall vents fixed louvre with bird proof wire)
SWV/1212	1200h x 1200w x 75d
SWV/912	900h x 1200 x 75d
SWV/99	900h x 900w x 75d
SWV/612	600h x 1200w x 75d
SWV/66	600h x 600w x 75d

Larnec Freeflow Louvres™ are the most popular and economic of the range. They are available in a wide range of standard and custom sizes, materials and finishes.

Larnec Freeflow Louvres™ are versatile in both performance and appearance. In more exposed areas, the stormproof blades should be considered.

Sentry™ Operable Wall Vent

Code	Description (wall vents closing louvre with bird proof wire)
SCV/1212	1200h x 1200w x 100d
SCV/912	900h x 1200 x 100d
SCV/99	900h x 900w x 100d
SCV/612	600h x 1200w x 100d
SCV/66	600h x 600w x 100d

Larnec Operable Louvres™ are designed for installations where the option of closing the louvres during cold or inclement weather is required. The louvres are operated manually with a handle.

Bird screen is standard on all louvres.
Louvres can be installed into doors.

How to specify

Contact your local representative.

Available from Larnec Doors & Systems 1800 657 536

Areas of use

- CLASS A
- CLASS B
- CLASS C

Options

- Custom sizes available
- Refer to Sentry™
Door colours for a full range of colour options

Sentry™

Door colours

Larnec Doors & Systems prides itself on its products and manufacturing knowledge, but we also realise that we need to use the best products available to us in our door construction, it is for this reason we use only the best product available, Colorbond®.

Larnec Doors & Systems supplies quality Colorbond® steel in the full range of designer colors available. Colorbond® steel has been a part of Australian building and design for well over 40 years.

For the full range available please refer to color chart below.



Larnec Doors Guarantee

Sentry™ Doors were created to meet demand for a door that is durable, resilient and competitively priced

Full industry colour range available in all Sentry™ door configurations

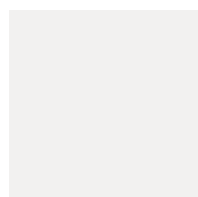

Surfmist SM



Evening Haze EH

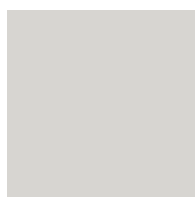

Shale grey SH



Classic Cream CC

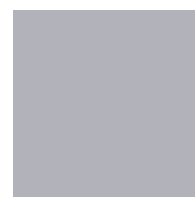

Dune DU



Windspray WY



Pale Eucalypt PE



Sandbank SK



Paperbark PB



Bushland BL



Ironstone IS



Wilderness WL



Jasper JP



Headland HL



Woodland Grey WG



Deep Ocean DO



Cottage Green CN

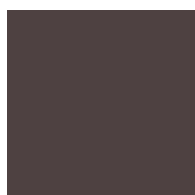

Loft LO



Manor Red MD



Monument MO

Larnec Doors & Systems

Locks & accessories

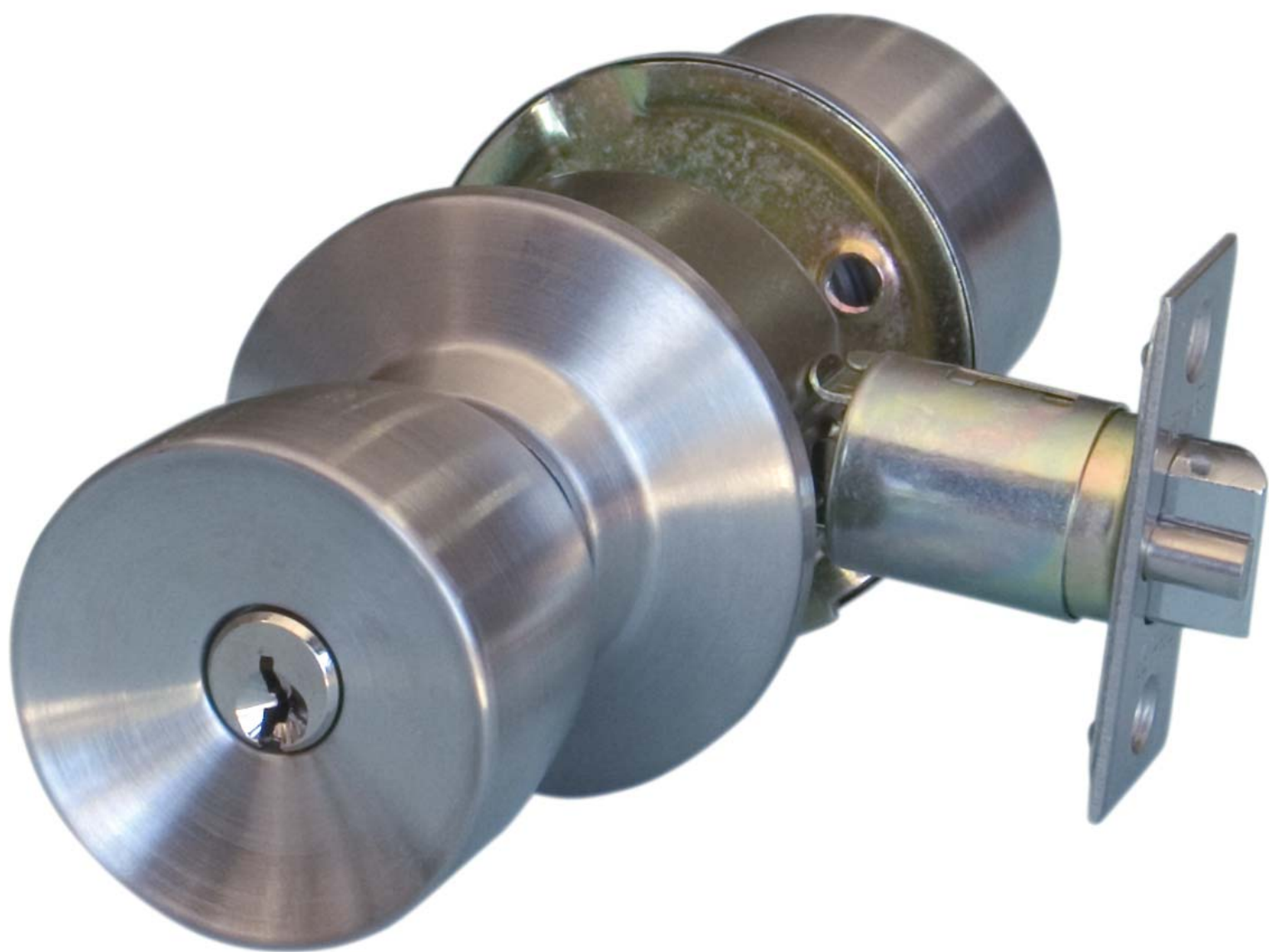

Larnec Doors & Systems

Locks & accessories

Larnec Doors & Systems has a full range of locks, levers, panic bars, dead bolts, door closers, latch guards, air relief grilles and anything else you may require. We have formed strong associations with some of the leading providers of door furniture worldwide.

We source only the best products available to us, and we stock a vast range from some of the world's leading companies. Just a few of the companies are listed below:

- Lockwood
- Gainsborough
- Carbine
- Dorma
- Ryobi

Should you have any special request items we are more than happy to provide a quote on these for you.

We carefully select our products to ensure quality and reliability



Larnec Doors Guarantee

Sentry™ Doors were created to meet demand for a door that is durable, resilient and competitively priced

Australia's leading manufacturer for all your door solutions

Please call our toll-free number for more information
1800 657 536

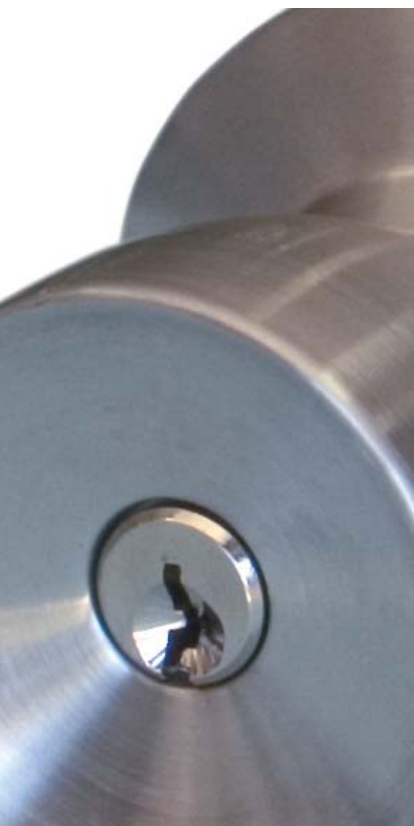

Larnec Doors & Systems

Locks & accessories

1100 Series

The 1100 series lockset is a knob/knob with a turn snib on the inside and is keyed from the outside. It is our standard lockset supplied with our 650 series doors.



40/60 Series Exit Lever

The 40/60 lockset is a knob/lever. It is also approved for a fire egress lockset as it can be opened from the inside while the lockset is locked by a key. It is the standard lockset supplied with our 200, 300, 400, 500 series and fire rated doors.



4000 Series Entrance Set

The 4000 series entrance set is a knob/knob. This lock is not approved as a fire egress but can be used with a 650 door where higher security is required.



6000 Series Exit Lever

The 6000 series exit lever is a lever/lever. This lock is approved as a fire egress handle and can be used with any of our 200 series or fire rated door sets.

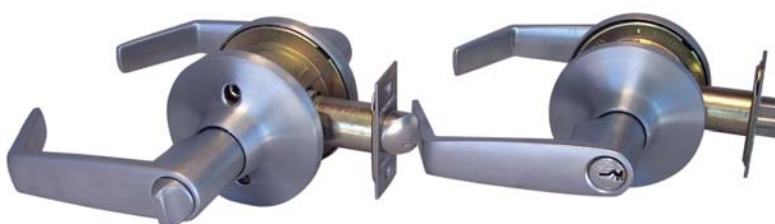

Larnec Doors & Systems

Locks & accessories

Deadbolt DBKK

This deadbolt is keyed from the inside and outside. The DBKK can also be used in conjunction with any of our standard entrance sets for extra security.



Deadbolt DBKS

The DBKS is basically the same as the DBKK except it is keyed from the outside only and has a turn snib on the inside. It can be used in conjunction with our other entrance sets as well.



Mortice Lock

The Mortice Lock offers a wide range of functions for commercial applications. With different backsets available and many options regarding furniture, this item is a very versatile product.



Lockwood 002 Exit Lever

The Lockwood 002 is a high quality deadlock which is keyed from the outside and has a lever on the inside. The 002 can be used by itself or in addition to any of our entrance sets.



Larnec Doors & Systems

Locks & accessories

Digital 002 Exit Lever

The Digital 002 is mainly for high security applications. There is no key used to activate the lock, instead you use a code. Like the normal 002 you still have a lever on the inside.



Panic Bar Exit Device

The panic bars are ideal for emergency exits e.g. fire escapes. They can be used in conjunction with our 200 or fire rated door sets where security and practicality is a must.

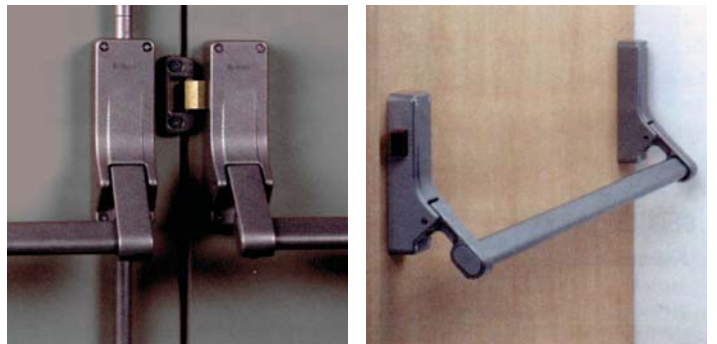

Push-Pull Plates

Push Pull Plates are ideal for circumstances where a lockset is not required. As there is no latch you simply have to push or pull to open the door. This application is ideal for high traffic or low security purposes.



Door Closer DC1 1503

This closer can only be used with our 650 or 200 series door sets. It is easy to install and combines stylish looks with basic operational features.



Larnec Doors & Systems

Locks & accessories

Door Closer DC2 2550

This is a heavy duty fire rated door closer. Its features include adjustable handing, which can come with a hold-open function and can be used with our 100, 200 or fire rated door sets.



Latchguards

The latchguard provides jimmy protection when fitted to the outside of the door. They have a zinc plated finish and are available in non-concealed or concealed fixings.



Panic Bolts

Panic Bolts are normally only used in conjunction with double door sets. They would be attached to the top and bottom of the non-active leaf to provide extra strength, while holding the doors firmly in place. They are supplied as part of a set with all our pre-hung double doors.



Spring Chain Retainer

The Spring Chain Retainer is designed to protect your door and building from damage. One end fastens to the jamb, the other to the top of the door, so if the wind catches it, the door won't hit your building or over-stretch the hinges.



Larnec Doors & Systems

Locks & accessories

Air Relief Grilles

Air Relief Grilles are mainly used in addition to our 100 and 200 series doors. They are made of high quality aluminium and can be powdercoated to match the door colour. Special sizes are available.



J Mould

The J Mould is designed to stop water from getting in behind the door jamb. It slides up the inside of your cladding and overhangs the door to prevent leakage. It comes in any colour from the Colourbond® range.



Vertical Stiles

Vertical Stiles can be used when you need to put a door where there is no framework. They are C-section, and can be made to match the rest of the framework in the building. Standard sections are 64mm, 100mm, 120mm and 150mm.



Seals

We stock a complete range of seals suitable for all purposes. Seals can be used on any of our 100 or 200 series doors. For further information on uses please contact our sales department.

Suitable for the containment of fire, smoke, sound, weather, rain, draughts, dust, energy, light and pests.



Fire



Smoke



Sound



Rain



Draughts



Disabled Access



Pests



Champion™ Stable Systems

Champion™ Stable Systems Range of products

Champion™ Stable Systems Doors & shutters

Champion™ Stable Systems Partitions



Champion™ Stable Systems

Range of products



Champion™ Stable Systems

Range of products



The Champion™ Stable Systems range of products have been designed and engineered to provide you with the best products to look after your horses. Our aim is to provide horse owners with a caring, practical and stress free environment when it comes to dealing with their horses.

At Champion™ Stable Systems (A Division of Larnec Doors & Systems) we offer all horse lovers the perfect solution to all of their stabling requirements. We can provide them with stable doors and stable shutters for their barns or sheds. We can also provide them with our innovative Champion™ Stable Systems Partitions. Our stable partitions can be used in a permanent fixed stable structure, or for those on the move as a portable horse stable that can be erected in minutes.

As with all products in our range, we ensure that only the best materials available are used in the construction of our products. When you are looking for stables you can't go past Champion™ Stable Systems.

We can manufacture a stable solution for any of your requirements.

Benefits of Champion™ Stable Systems

Features

- Pre-assembled panels
- Clean & safe design
- Pre-finished materials
- Permanent or portable

Benefits

- Ease of installation
- No sharp edges or corners
- Maintenance free
- Versatile



Champion™ Stable Systems Doors & shutters

Champion™ Stable Systems has provided stable doors and shutters to numerous clients across Australia and overseas. Champion™ Stable Systems doors and shutters are used by the racing industry, right through to the hobby farmer.

Champion™ Stable Systems Doors and shutters are the perfect system for turning any shed or barn into a Champion™ Stable Systems. Being pre-hung with Colorbond® and powdercoated finishes, they blend with the building while remaining practical to use.

These products have been designed to be:

- Easier, safer and smarter
- And are used by some of the industries most respected companies



Larnec Doors Guarantee

Sentry™ Doors were created to meet demand for a door that is durable, resilient and competitively priced

Australia's leading manufacturer for all your door solutions

Please call our toll-free number for more information
1800 657 536

The ideal system for turning any shed or barn into a Champion™ Stable



Champion™ Stable Systems

Doors & shutters

Code	Description
800/37	Stable door 2400 x 1150
800/37s	Stable door 2040 x 1150

Code	Description
860/37	Double shutter 900 x 600 x 600

Stable Doors

The Champion™ Stable Systems Door has been designed with the ease of usability as a priority. The strong construction of the door ensures years of maintenance free use, giving a clean appearance to the stable building. The door is a split door providing many options for its uses. Use the door as an exit door, or open the top half only to allow the horse a view and to let in fresh air.

The doors come in two heights, according to the height of the building's side wall.

The doors are reversible, making them universal to hang.

Stable Shutters

The Champion™ Stable Systems Shutters have been designed to allow the movement of fresh air into the stable complex.

These shutters are by far the most convenient and easiest product to install. They can be fitted into virtually any type of building and/or opening.

For more information please request fact sheet number: 800, 850 or 860

How to specify

Contact your local representative

Available from Larnec Doors & Systems 1800 657 536

Areas of use

- CLASS C

Options

- J-flashing
- Marine ply lining
- Square mesh
- Custom sizes available
- Refer to Sentry™
Door colours for a full range of colour options

Champion™ Stable Systems Partitions

Champion™ Stable Systems has provided stable doors and shutters to numerous clients across Australia and overseas. Champion™ Stable Systems doors and shutters are used by the racing industry, right through to the hobby farmer.

Champion™ Stable Systems Partitions have been designed to create a caring, stress free environment for owners and their horses alike. They have been designed to be practical, serviceable, functional and safe for the housing of horses.

The Champion™ Stable Systems Partitions are the perfect choice for both permanent and portable stables. The permanent stables have been designed to fit into any structure and transform it into a Champion™ Stable Systems complex.

The portable stables can be used with an open roof, inside a marquee or as shedding, making them suitable for all functions where temporary accommodation is required.

Only the best of materials have been used to give the owner piece of mind that their stables are going to give them the years of use they are looking for. Champion™ Stable Systems compliment and add the finishing touch for a person who has pride in their horses and surroundings.

The perfect choice for permanent and portable stables



Larnec Doors Guarantee

Sentry™ Doors were created to meet demand for a door that is durable, resilient and competitively priced

Australia's leading manufacturer for all your door solutions

Please call our toll-free
number for more information
1800 657 536



Champion™ Stable Systems Partitions

Code	Description
SPSW	1 front wall with swing door
SPSL	1 front wall with sliding door
SPSP	1 front wall with split 50/50 door
SPVD	1 front wall with V door
SPWP	1 side wall

- All partitions comprise of 3 panels and are approximately 3.6m x 2.4m high
- Front wall consists of 2 panels plus 1 door with fittings
- Side wall consists of 3 panels with fittings

Code	Description
SPSW	Stable partition swing door
SPSL	Stable partition sliding door
SPSP	Stable partition split door
SPVD	Stable partition V door
SPWP	Stable partition side wall

Champion™ Stable Systems can be made to any specifications required, should it be a straight line, box style, fixed or portable solution you are after, we can provide the answers. All products in the Champion™ Stable Systems range are designed and engineered to provide you with peace of mind, knowing your animals are being safely and securely looked after.

Stable Partitions

Benefits that speak for themselves – and for Champion™ Stable Systems.

- Fully hot-dipped galvanised
- 2400mm high x 1200mm wide panels – standard wall 3600mm wide
Custom sizes available
- Fully pre-assembled panel ready for quick and easy installation
- Swing door or sliding door
- Fully welded, no sharp edges or corners
- Permanent or portable – more versatile
- Full range of accessories and options

**For more information please request fact sheet number:
ST or BX**

How to specify

Contact your local representative

Available from Larnec Doors & Systems 1800 657 536

Areas of use

- CLASS

Options

- Sliding door
- Split door
- 1 door
- View 'V'
- View gate
- Rug rail
- Tie ring
- Utility rack
- Feed bin
- Powdercoating
- Timber types
 - Marine ply
 - Natural ply
 - Hardwood
 - Jarrah or equivalent

Champion™ Stable Systems Accessories

32 Litre Stable Feeder



- Replaces old tin feeder
- Will not corrode or dent
- Galvanised brackets inside and out
- Very robust

Hayrack



- Large feed bin saves feed falling on ground
- Fits whole biscuit of hay
- Fits on rail or fence
- Strong galvanised brackets
- Withstands rough treatment

45 Litre Drinker



- Enclosed 15mm float and cover
- 50mm drain bung (easy cleaning)
- Strong galvanised steel mounting bracket
- Proven in saleyards

Rug Rack



- The rug rack is 900mm long and is attached to the outside wall of the stable partition

Rotating Poly Feed Bin



- The long lasting rotating feed bin allows the owner to feed the horse without entering into the stable
- The feeder system is integrated into the stable partition
- The rotating feeder is a great time saver, allows for easy cleaning and is a practical solution for OH&S

How to specify

Contact your local representative

Available from Larnec Doors & Systems 1800 657 536



Customer Care

Larnec Doors & Systems Warehouse & packaging

Larnec Doors & Systems Warranty

Larnec Doors & Systems Customer care commitment

Larnec Doors & Systems Easy contact guide



Larnec Doors & Systems Warehouse & packaging

Larnec Doors & Systems handles all the packaging and despatch requirements for all products ordered through us. We take great care in ensuring that all doors are wrapped and packaged in a unique way to limit any chance of damage during transport.

Larnec understands that their primary mission is to deliver their customers the doors they requested in pristine condition and on-time.

Our warehousing now allows us to keep more standard stock items in shelf as we are fully committed to reducing the times for order fulfillment.

We are effective in our packing techniques, and with a 99.97% "perfect arrival factor," we know we have a robust and reliable process in delivering doors to our customers in perfect condition.



Larnec Doors Guarantee

Sentry™ Doors were created to meet demand for a door that is durable, resilient and competitively priced

Australia's leading manufacturer for all your door solutions

Please call our toll-free number for more information
1800 657 536

From production to the warehouse on-time delivery is our committment



DOOR TYPE	DOOR TYPE	DOOR TYPE	DOOR TYPE	DOOR TYPE
01000	01000	01000	01000	01000
01001	01001	01001	01001	01001
01002	01002	01002	01002	01002
01003	01003	01003	01003	01003
01004	01004	01004	01004	01004
01005	01005	01005	01005	01005
01006	01006	01006	01006	01006
01007	01007	01007	01007	01007
01008	01008	01008	01008	01008
01009	01009	01009	01009	01009
01010	01010	01010	01010	01010
01011	01011	01011	01011	01011
01012	01012	01012	01012	01012
01013	01013	01013	01013	01013
01014	01014	01014	01014	01014
01015	01015	01015	01015	01015
01016	01016	01016	01016	01016
01017	01017	01017	01017	01017
01018	01018	01018	01018	01018
01019	01019	01019	01019	01019
01020	01020	01020	01020	01020
01021	01021	01021	01021	01021
01022	01022	01022	01022	01022
01023	01023	01023	01023	01023
01024	01024	01024	01024	01024
01025	01025	01025	01025	01025
01026	01026	01026	01026	01026
01027	01027	01027	01027	01027
01028	01028	01028	01028	01028
01029	01029	01029	01029	01029
01030	01030	01030	01030	01030
01031	01031	01031	01031	01031
01032	01032	01032	01032	01032
01033	01033	01033	01033	01033
01034	01034	01034	01034	01034
01035	01035	01035	01035	01035
01036	01036	01036	01036	01036
01037	01037	01037	01037	01037
01038	01038	01038	01038	01038
01039	01039	01039	01039	01039
01040	01040	01040	01040	01040
01041	01041	01041	01041	01041
01042	01042	01042	01042	01042
01043	01043	01043	01043	01043
01044	01044	01044	01044	01044
01045	01045	01045	01045	01045
01046	01046	01046	01046	01046
01047	01047	01047	01047	01047
01048	01048	01048	01048	01048
01049	01049	01049	01049	01049
01050	01050	01050	01050	01050
01051	01051	01051	01051	01051
01052	01052	01052	01052	01052
01053	01053	01053	01053	01053
01054	01054	01054	01054	01054
01055	01055	01055	01055	01055
01056	01056	01056	01056	01056
01057	01057	01057	01057	01057
01058	01058	01058	01058	01058
01059	01059	01059	01059	01059
01060	01060	01060	01060	01060
01061	01061	01061	01061	01061
01062	01062	01062	01062	01062
01063	01063	01063	01063	01063
01064	01064	01064	01064	01064
01065	01065	01065	01065	01065
01066	01066	01066	01066	01066
01067	01067	01067	01067	01067
01068	01068	01068	01068	01068
01069	01069	01069	01069	01069
01070	01070	01070	01070	01070
01071	01071	01071	01071	01071
01072	01072	01072	01072	01072
01073	01073	01073	01073	01073
01074	01074	01074	01074	01074
01075	01075	01075	01075	01075
01076	01076	01076	01076	01076
01077	01077	01077	01077	01077
01078	01078	01078	01078	01078
01079	01079	01079	01079	01079
01080	01080	01080	01080	01080
01081	01081	01081	01081	01081
01082	01082	01082	01082	01082
01083	01083	01083	01083	01083
01084	01084	01084	01084	01084
01085	01085	01085	01085	01085
01086	01086	01086	01086	01086
01087	01087	01087	01087	01087
01088	01088	01088	01088	01088
01089	01089	01089	01089	01089
01090	01090	01090	01090	01090
01091	01091	01091	01091	01091
01092	01092	01092	01092	01092
01093	01093	01093	01093	01093
01094	01094	01094	01094	01094
01095	01095	01095	01095	01095
01096	01096	01096	01096	01096
01097	01097	01097	01097	01097
01098	01098	01098	01098	01098
01099	01099	01099	01099	01099
01100	01100	01100	01100	01100

Larnec Doors & Systems Warranty

Sentry™ Metal Clad Doors are a superior product. Sentry™ Doors were created to meet demand for a door that is durable and resilient, competitively priced, locally manufactured, readily available, easy to work with, and will retain its attractiveness for many years to come. Larnec's doors meet all of these criteria.

Warranty

Your Sentry™ Metal Clad Doors, manufactured by Larnec Doors & Systems, will continue to protect your premises for a period of 24 months, provided the following warranty conditions are observed. If our product fails to meet these requirements we will replace the defective part or parts to the discretion of a Larnec Doors & Systems inspection officer.

Warranty Conditions

- 1 This warranty will only be binding if issued in response to a Larnec Doors & Systems standard application form, with all of the information required to be supplied on it, accurately completed. The application form must be presented to Larnec Doors & Systems within six months of the installation of your Sentry™ door.
- 2 This warranty will not be valid unless signed by Larnec Doors & Systems Official Warranty Manager, or one of his or her authorised deputies. Warranties signed by other Larnec Doors & Systems personnel, rollformers, building material suppliers or any other person will unfortunately not be acceptable.
- 3 This warranty is given for the benefit of the first owner or occupier of the building only and claims by parties other than the person appearing on Larnec Doors & System's copy of the warranty will not be recognised.
- 4 This warranty does not apply to damage or deterioration to your Sentry™ door which is caused by any of the following:
 - 4.1 Impact or contact with objects or substances which fall, are precipitated onto, are applied to or are in any way brought into proximity with the door as a result of direct or indirect human intervention.
 - 4.2 Collapse or movement of the structure on which the door is mounted or any removal or weakening of the door's supports or foundations.
 - 4.3 Deliberate or careless acts or omissions on your part, or on the part of paint suppliers, metal producers, rollformers, fabricators, builders, subcontractors, architects, specifiers or any other party excluding Larnec Doors & Systems.
 - 4.4 Exposure to abnormally corrosive environments or conditions including marine environments, coastal areas, polluted or toxic atmospheres, or areas where chemical wastes or acidic substances are present. Information on systems available for use in these environments is available from us on request.
 - 4.5 Failure to handle, store, install or maintain the doors in accordance with Larnec Doors & System's published recommendations (available from us on request) and normal prudent trade practice.
 - 4.6 Failure to wash your Sentry™ door using a soft brush and fresh clean water at least once every two months.
 - 4.7 The periodic build-up or accumulation of water or moisture-containing materials on or near the affected part of the door.
 - 4.8 Contact with copper or similar corrosive substances.
 - 4.9 Incorporation into, or use in connection with door materials manufactured by someone other than Larnec Doors & Systems.
 - 4.10 Any abnormal natural phenomenon such as earthquakes, fires, floods, lightning, abnormally strong winds, abnormally heavy hail, or the build-up of snow or other natural substances.
- 5 No downgraded doors will be covered by the warranty.
- 6 In the event that Larnec Doors & Systems does replace any defective doors or parts or repaint any part of your door cladding in accordance with the above warranty, you should note that there are likely to be colour and texture differences between the new and the old portions of the cladding. Over a period of time and as a result of the normal action of the elements, your Sentry Door cladding, like any other cladding, will inevitably chalk or fade to some degree.
- 7 If any doors are replaced or repainted in satisfaction of this warranty obligation, the above warranty will apply to those replacement or repainted doors but only for the unexpired portion of the original warranty.
- 8 Larnec Doors & Systems, if agrees to repair or replace at its option, unfinished and in the form originally supplied and without charge, any door found to be defective within the meaning of the warranty. Larnec Doors & Systems will not be held responsible to additional charges of hanging, painting or other charges arising from the replacement of doors.
- 9 Doors exceeding 2040mm in height and 914mm in width will not be covered by this warranty.
- 10 Larnec Doors & Systems will not recognise any claim under your warranty unless it is accompanied by this warranty certificate and the claim has been made within one month of the defect coming to your attention.
- 11 Larnec Doors & Systems expressly disclaims any responsibility for any other warranty issued by any other party in respect to any component of your Sentry™ Door or the specification, design, manufacture or installation thereof. All claims under warranties issued by third parties must be directed to those third parties.
- 12 This warranty is given in substitution for any other warranty relating to your Sentry™ Door, which may be implied by law, or which may have been given to you by any officer, employee or agent of Larnec Doors & Systems and issued, or which may be comprised in any representation made to you, whether before or after that time.
- 13 No variation, addition to or deletion from this warranty will be valid or binding unless recorded in writing and signed by Larnec Doors & Systems Official Warranty Manager or one of his or her authorised deputies.
- 14 Glazing – All glazing procedures in accordance with AS1288.

Care And Maintenance

Regular maintenance should be provided to prevent deterioration.

- 1 Clean doors using a soft brush and fresh clean water and dry with a soft cloth, at least once every two months.
- 2 Keep all stones and any loose objects free from obstructing the underneath of the door, whether in opening or closing of the door.
- 3 Clean glass with soft cloth and any recommended glass cleaner.
- 4 Check door furniture and hinges for any wear or failure to operate correctly at least once every two months.
- 5 Maintenance programs can be obtained from Larnec Doors & Systems.

Larnec Doors & Systems

Customer care commitment

The management and staff of Larnec Doors & Systems have prepared (and hereby, adhere to) the following customer care doctrine:

- 1** You will receive friendly, courteous, prompt and efficient service at all times and from all staff members.
- 2** You will be respected, for you are more than a customer, you are our immediate future and the sole reason for our business continuance.
- 3** Our practical products and services will never lose sight of the ultimate goal; “adding value to your business”.
- 4** We will conduct our business with absolute honesty and integrity.
- 5** We will honour all of our commitments and warranties.
- 6** We will be openly accessible at all times.
- 7** We will communicate with you frequently.
- 8** We welcome your comments, suggestions, praises and criticisms.
- 9** We promise to act appropriately and promptly to ensure your dealings with our business are harmonious and to your satisfaction.
- 10** We promise to obey these customer care guidelines at all times.

Copyright 2009 Larnec Doors & Systems The material used in this publication remains the property of Larnec Doors & Systems and may not be reproduced in any way without written permission. The company reserves the right to change and/or update details and/or specifics without notice. Colorbond® names are registered trademarks of BlueScope Steel Limited.

This product catalogue is not to be reproduced in any form without written permission from Larnec Doors & Systems. Information printed in this document or communicated by the manufacturers, distributors or any agent is subject to change without notice. Larnec Doors & Systems will accept no liability for the accuracy of information supplied.

Larnec Doors & Systems

Easy contact guide

The following chart will assist us to provide you with a better and faster Customer Service Standard.

Your requirement	Ask for
Product information and general advice prior to ordering	Sales Department Phone 1800 657 536 sales@larnecdoors.com
Enquiry on the status of an order which has been placed with Larnec (Note: It would assist greatly if you have your order number and date of order placement)	Scheduling Department Phone 03 5033 2344 info@larnecdoors.com
Enquiry on invoices, credit notes or any account or remittance matter (Note: It would assist greatly if you have your details ready; invoice number etc.)	Accounts Department Phone 03 5033 2344 accounts@larnecdoors.com
Tendering	Tenders Phone 03 5033 2344 sales@larnecdoors.com





Lar nec Doors & Systems

FREECALL 1800 657 536

1-3 Shepherd Road, Swan Hill Vic 3585

Phone 64 3 5033 2344

Fax 64 3 5033 2030

sales@larnecdoors.com

www.larnecdoors.com