



LIFESTYLE SERIES

LIBERTY

1

The **LIBERTY** residential lift is manufactured in Australia and has great appeal to Architects, Designers, Builders and Home Owners.

With most of us leading increasingly busy lives, the **LIBERTY** offers time saving access in multi level homes, and people of all ages can see the advantages of having a **LIBERTY** lift installed in their home.

The **LIBERTY** offers a quick and easy transfer between levels for carrying groceries, laundry, kids gear, suitcases and numerous other items, as well as for you and your visitors!

Some reasons why home owners are installing the **LIBERTY**:

- The **LIBERTY** is an investment that adds value to your home.
- Quick easy installation means minimal disruption to your home.
- The **LIBERTY** does not require as much space as other lifts.
- Competitively priced and great value for money.
- Traction Drive: Geared roller chain suspension with a counterweight for a smoother, more comfortable, safer ride.
- Low maintenance costs.
- 240 volt single phase power only.



Need a lift?

Here's what you need to know.

Master Lifts has been serving Australian Architects, Designers, Builders and Home Owners for over eighteen years. Our goal is to provide cost effective quality lift systems. We programme carefully and deliver on time.





LIBERTY

2



BENEFITS

- A soft start and a soft stop. This gives you a smoother ride, a refinement usually only found in more expensive lifts.
- Smaller space requirement. Because the **LIBERTY** comes in its own aluminium shaft it offers a big space saving compared to conventional lifts which usually need a structural block wall shaft.
- There is no requirement for a separate machine room – just a small cabinet similar to a meter box. Another space saving feature!
- Easy installation into a new building as it has its own shaft. The special design also makes for easy retrofitting into an existing building and saves you money.
- Emergency battery (UPS) lowering of the car in the event of household power failure. You will not get stuck in your lift during a power outage.
- A digital position indicator display in the car operating panel that shows you which level you are on.

FEATURES:

- Fully automatic operation.
- Travel of up to 9 metres.
- Up to 4 stops.
- Soft start / soft stop.
- Speed of 0.25m/sec.
- Low noise levels.
- Smaller space requirement.
- A pit is not essential if a small ramp is used.
- Low overhead requirements.
- MRL (Machine Room Less). Only needs a small control cabinet.
- Comes in its own shaft.
- Emergency battery (UPS).

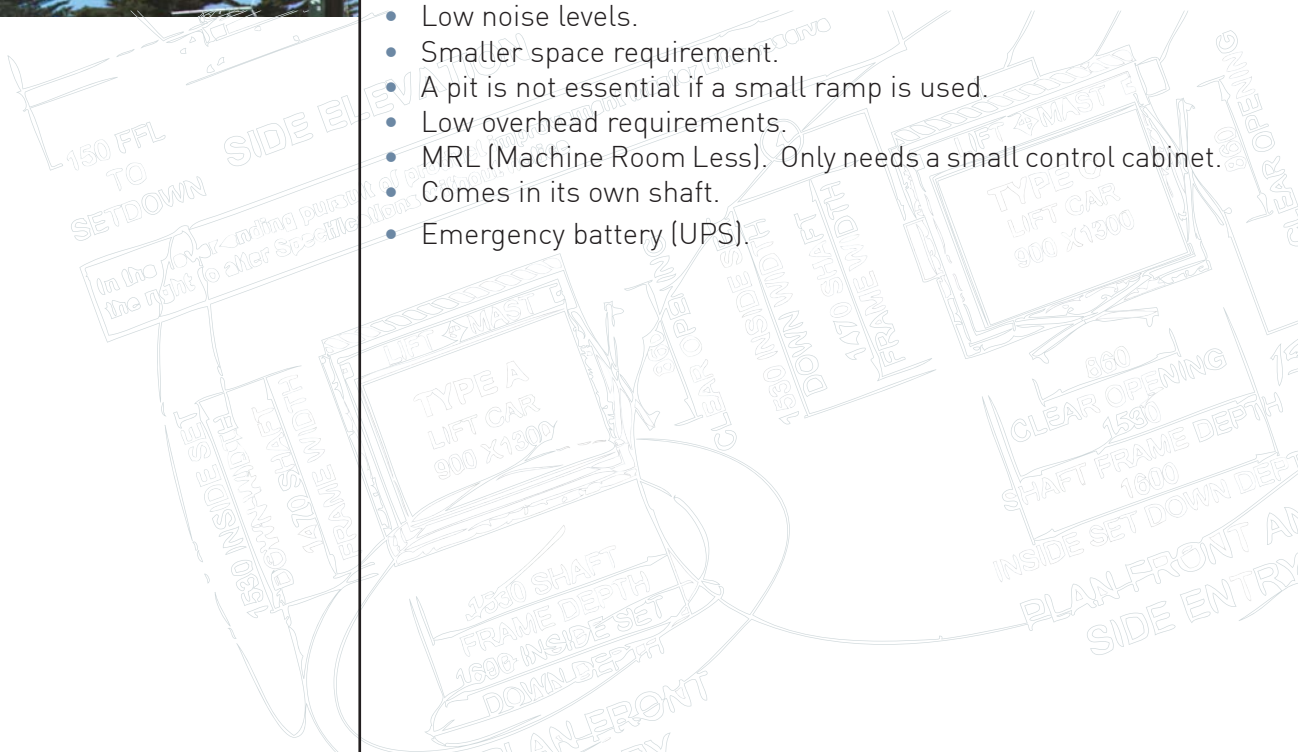



LIBERTY

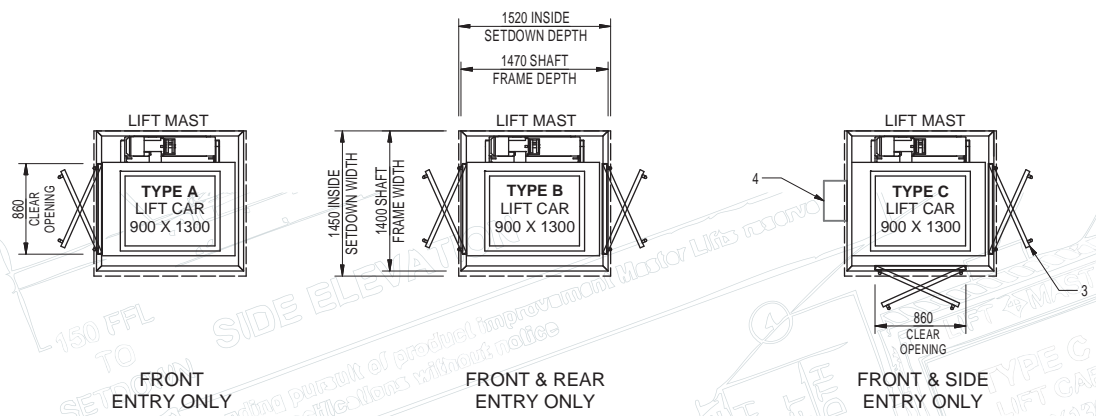
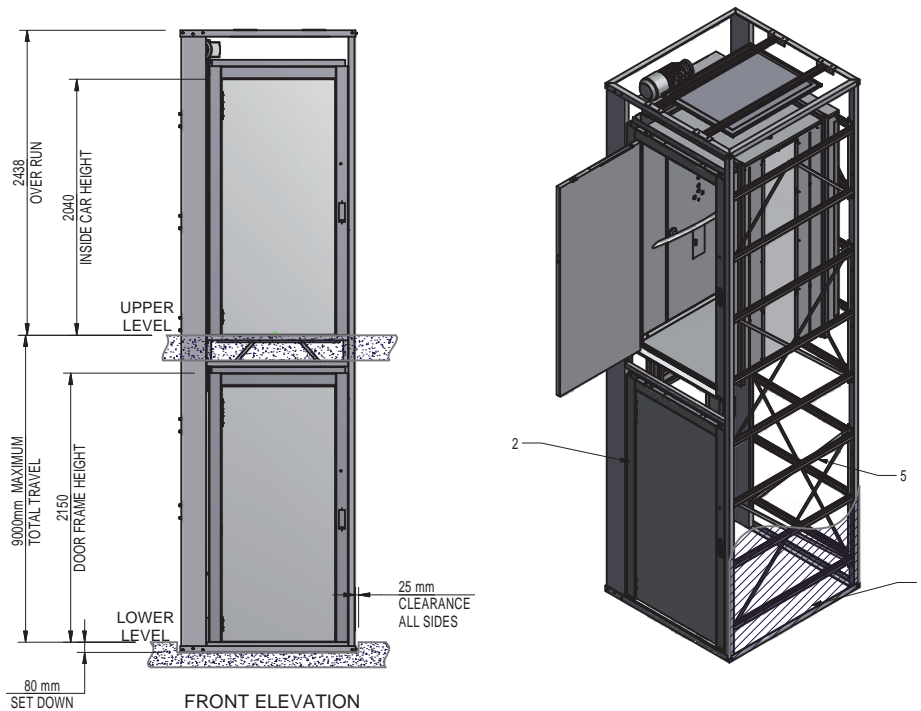

LEGEND	NOT FOR CONSTRUCTION	LIBERTY Model 1000 RESIDENTIAL LIFT
1 CLADDING BY OTHERS	5 TOP HAT SECTION FOR SECURING EXTERNAL CLADDING	AS 1735 Part 16 & PART 18
2 STEEL DOOR FRAME		FLOOR TO FLOOR TRAVEL UP TO 9000MM UP TO 4 LEVELS
3 OPTIONAL DOOR HINGING		CARRYING CAPACITY UP TO 300KG
4 CONTROL CABINET CAN BE MOUNTED ON THE MAST SIDE, BACK OR IN CLOSE PROXIMITY (SIZE 620H x 584W x 170D)		



PASSENGER CAR:

- 300Kg carrying capacity
- Car size 900mm x 1300mm x 2040mm high.
- Maximum of 2 entrances (front, back or side).
- Choice of 4 laminate on MDF finishes as standard.
- Recessed down lights that also operate as emergency lights.
- Digital position indicator display in car operating panel.
- Recessed emergency telephone.
- Stainless steel hand rail.
- Stainless steel control panel with a keyed on/off switch, stop button, emergency alarm button and push button for each landing.

LANDING DOORS:

- Hinged timber doors with stainless steel pull handle and push plate.
- Each landing has an electro mechanical interlocking device that prevents the door from being opened when the lift is not at that landing.
- Concealed hydraulic door closers.

OPTIONS:

- Aluminium framed landing doors fitted with laminated safety glass.
- View panel in timber doors.
- The car walls can be customised to suit your décor with timber, laminates, stainless steel etc.
- Powered door openers and closers.
- Customised options available on application.

AUSTRALIAN LIFT CODE:

- Design registered as a passenger lift under AS 1735 Part 16 and Part 18.

WARRANTY:

Three Years (conditions apply)

