

# SUPATILE 10

Premium Fully Accessible Ceiling System

**NEW!**

- Slim Line Joints
- 100% Accessibility
- Creative Design



# SUPATILE 10

Premium Fully Accessible Ceiling System

*Does your ceiling system provide all these benefits?*

- ✓ - 100% accessibility for services
- ✓ - Quick to install
- ✓ - Fits into standard ceiling suspension systems
- ✓ - Visual appeal with design creativity
- ✓ - A range of contemporary timber finishes
- ✓ - Service panels for lights, exit signs etc.
- ✓ - Demarcation of specific areas
- ✓ - Acoustic Panels for noise reduction
- ✓ - Perimeter Upstand for floating ceilings
- ✓ - Meets all Green Star Requirements
- ✓ - Fire Retardant version available
- ✓ - Easy to wipe clean
- ✓ - Durability

*Supatile 10 ticks all the boxes!*

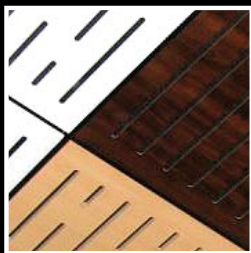
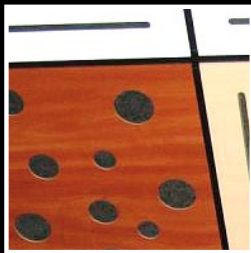
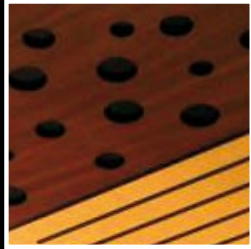

## SUPAFINISH Concept Veneers & Colours



Hoop Pine



Fusion Maple



Beech



Tasmanian Oak



Spotted Gum



Smooth Mahogany

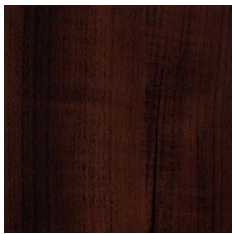

Cracked Cherry

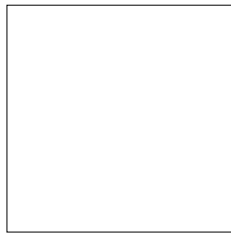

White



Matt Silver



Black

## SUPATILE 10 Decorative & Acoustic Options

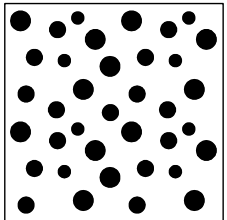

Bubbles

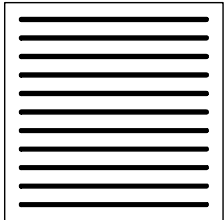

Stripe

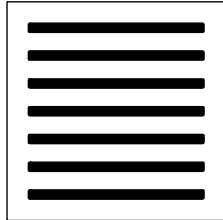

Zebra

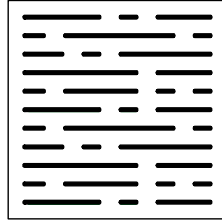

Cyberspace

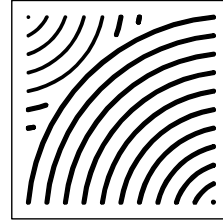

Ripple

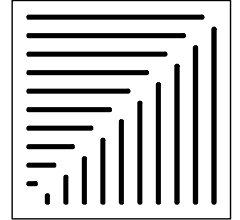

Angle

\* Also available as a solid panel 'Smooth'

## SUPATILE 10 Acoustic Service Panels Suits services up to 150mm diameter

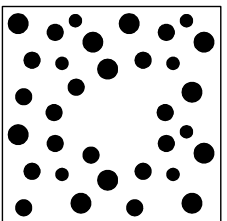

Bubbles SP

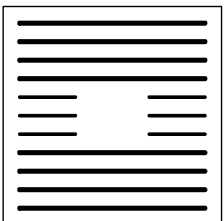

Stripe SP

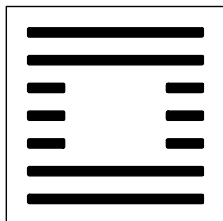

Zebra SP

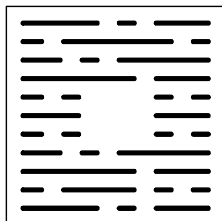

Cyberspace SP

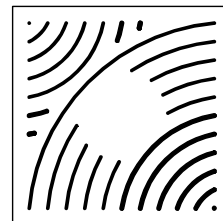

Ripple SP

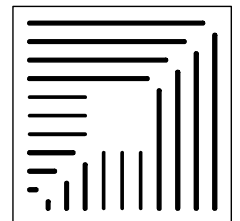

Angle SP



# SUPATILE 10 How it works...

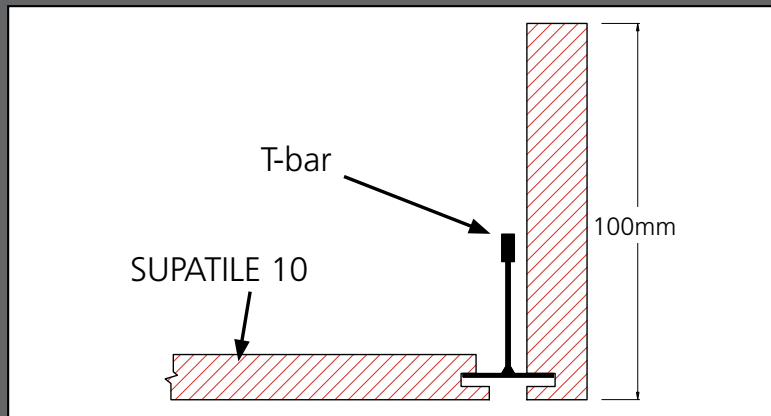
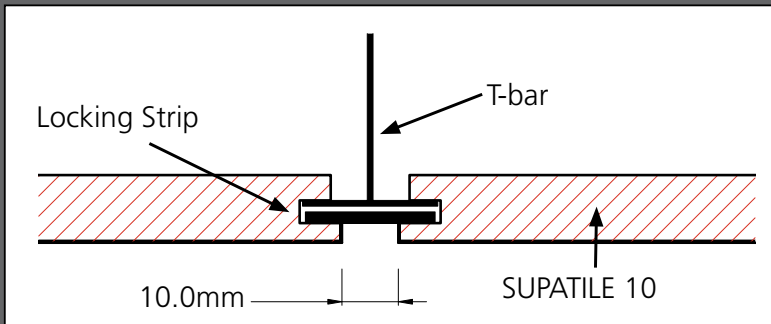

## Suggested Specification Wording

### SUPATILE FEATURE CEILING

- ➔ Ceiling to be SUPATILE 10 shadowline grid system.
- ➔ Grid to be 600x600 modules in black colour to be supplied and installed in accordance with SUPAWOOD's SUPATILE 10 Framing Requirements.
- ➔ Panel Finish to be ... with matching edges.
- ➔ Acoustic tile pattern to be ... in locations shown on RCP.
- ➔ Panel installation to be in accordance with SUPAWOOD's SUPATILE 10 Panel installation and removal procedure and AS/NZS 2785.

## For more product information:

SUPAWOOD produce an extensive range of market-leading panel systems and are looking forward to working with you to deliver on your requirements.

**Website:** [www.supawood.com.au](http://www.supawood.com.au)

**Phone:** Toll Free 1800 002 123

**Fax:** 02 6331 8885

**Email:** [supatile@supawood.com.au](mailto:supatile@supawood.com.au)

