

# ARCHITECTURAL GRATES + DRAINS



Stormtech

™



**Grate innovation.**



## Slimline by Stormtech.

### WELCOME

The Slimline series is a patented, Australian designed and made linear grated drain system that can be used anywhere a high performance, high quality contemporary style drainage solution is needed.

Stormtech grates are made of stainless steel and are manufactured in Australia to ensure consistent high quality and timely supply.





**Grate  
versatility.**

## ARCHITECTURAL AND RESIDENTIAL

**Balconies**

**Bathrooms**

**Courtyards**

**Doortracks**

**Driveways**

**Paved Areas**

**Patios**

**Pools**

**Suspended Slabs**

**Thresholds**

**Wet Areas**

A narrow profile and high efficiency lineal drainage system that creates an aesthetically pleasing solution to the traditional grated drain.

The quality finish, blends well with designed contours and suits a variety of surfaces including pavers, tiles, concrete and vinyl.





**Grate  
versatility.**

## COMMERCIAL PROJECTS

**Airports**

**Carparks**

**Parks and Playgrounds**

**Public Areas**

**Sporting Grounds**

**Gymnasiums**

**Thresholds**

The range of Stormtech Slimline products are suitable for many commercial purposes and large-scale outdoor applications.

Aesthetically pleasing, they provide extreme efficiency and ease of access in high traffic areas.





**Grate  
simplicity.**

## HOSPITALS AND AGED CARE

**Bathrooms**

**Doortracks**

**Dining areas**

**Outdoor areas**

**Showers**

**Thresholds**

Originally designed for those with special needs, Stormtech Slimline grates allow hobless entry to the shower and more room to manoeuvre in the bathroom. The shower floor falls in one direction, giving greater stability to a wheelchair or stool, and avoids rocking.

Stormtech Slimline grates allow disabled people a greater self-sufficiency in the bathroom.

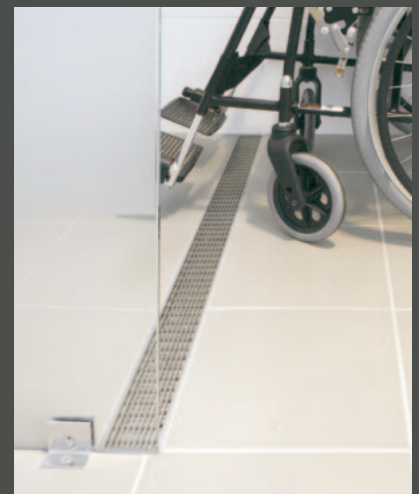

**Grate  
innovation.**

## HOSPITALITY

**Bars and Restaurants**

**Bathrooms and Showers**

**Hotels and Resorts**

**Kitchens**

**Pools**

**Thresholds**

Unique in their efficiency and versatility, Stormtech grates are ideal for new construction as well as retrofitting during renovation.

Providing a beautiful finish and ease of access for architectural requirements.



# PRODUCT RANGE

## ARG Series

Modular site finish system, wedge wire grate, manufactured from 316 grade stainless steel combined with a UPVC channel.

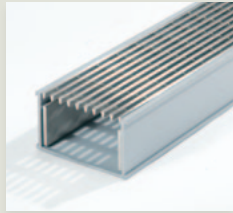

Available in kits or individual components.

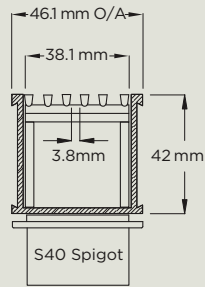

**38ARG**

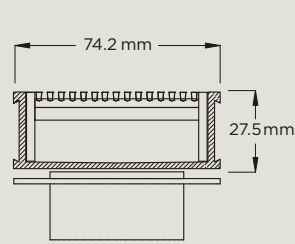

**65ARG25**

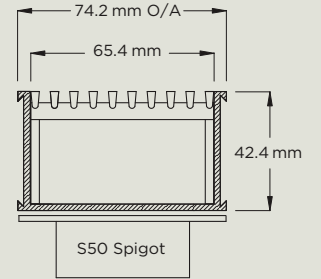

**65ARG40**

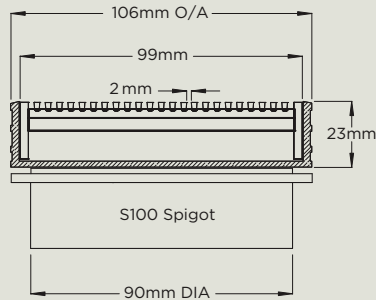

**100ARG20**

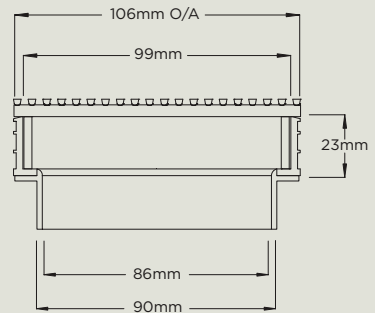

**100ARG30**

## ARI Series

All stainless steel, modular product. Featuring a stainless steel grate and stainless channel.



Available in kits or individual components.

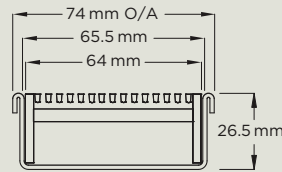

**65ARI25**

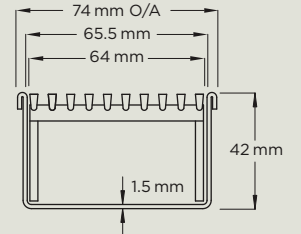

**65ARI40**

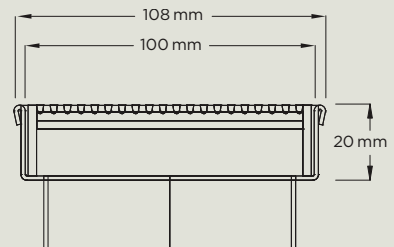

**100ARI20**

## ARIC Series

The ARIC Series is a fully finished ready to install all stainless featuring a wedge wire architectural stainless steel grate and channel manufactured from 316 marine grade. Available in 25mm, 65mm and 100mm wide.

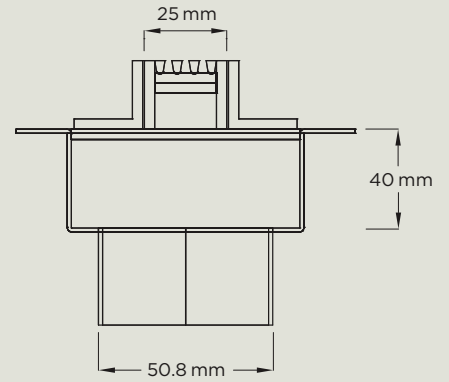

**25SDIF**

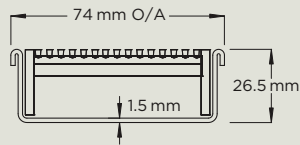

**65ARIC25**

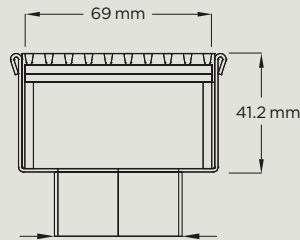

**65ARIC40**

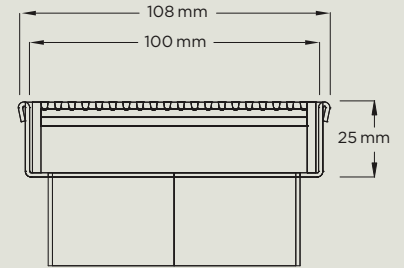

**100ARIC25**

Available in kits or individual components.

## TIF Series

Featuring a 316 grade stainless steel tile insert frame, the TIF series is designed to blend the drainage system perfectly with your chosen solid surface finish.

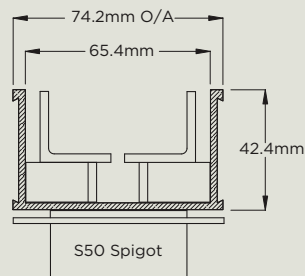

**65TIFG40**

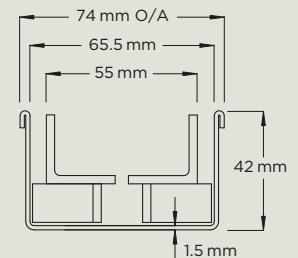

**65TIFI40**

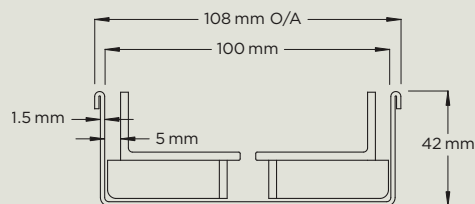

**100TIFI40**

(Custom Fabrication)

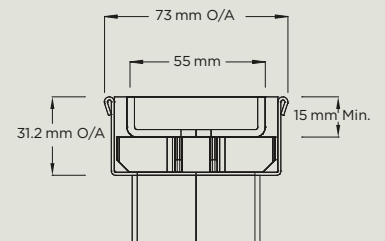

**65TIFI30**

Available in kits or individual components.





## PS Series

Featuring a stainless steel slot perforated grate combined with a UPVC or stainless channel.

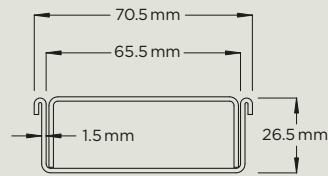

65PSI25

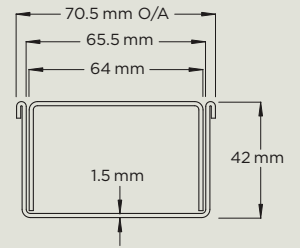

65PSI40

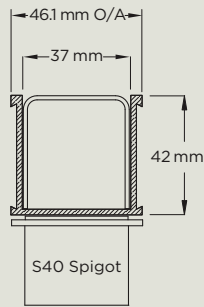
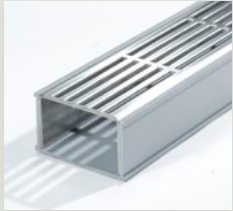

38PSG

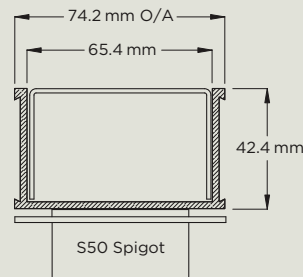

65PSG40

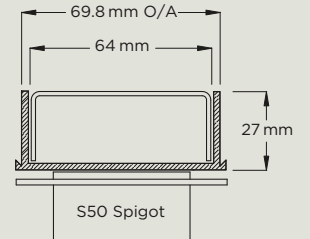

65PSG25

Available in kits or individual components.

## PH Series

Featuring 316 grade stainless steel circular hole punched grate, combined with a PVC or stainless steel channel.

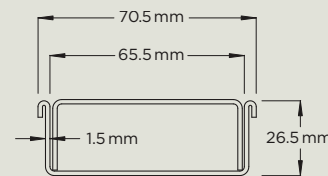

65PHI25

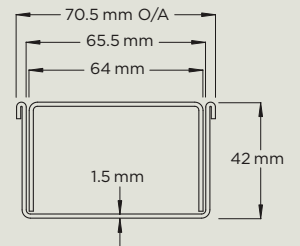

65PHI40

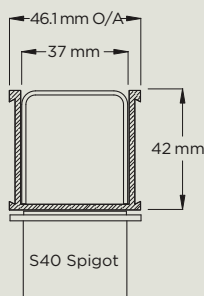

38PHG

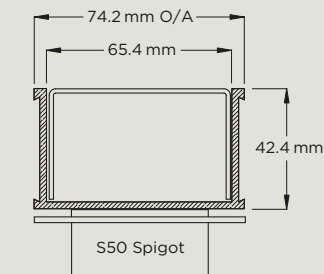

65PHG40

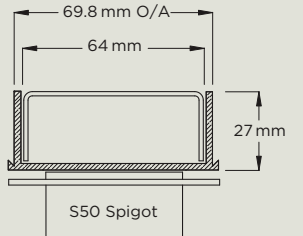

65PHG25

Available in kits or individual components.

## SQ Series



A more traditional square drain, manufactured from 316 grade stainless steel. Available with an architectural wedgewire grate, or a tile insert frame to incorporate any chosen tile or solid floor surface material.

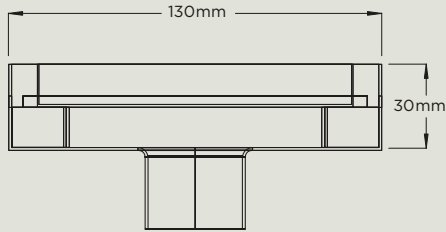

**SQ100TIF**

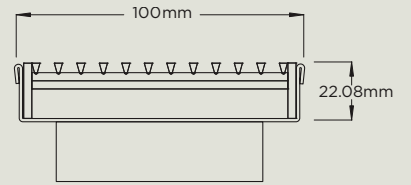

**SQ100AR**

## Threshold Series

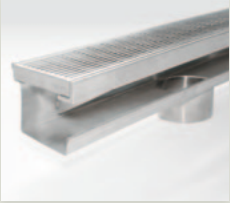

Featuring a linear stainless steel architectural, wedgewire grate, with an integrated concealed channel section which connects all sub sill sections for doortracks and thresholds. Allows doorsills to be drained while having internal and external floor surfaces with zero stepdown.

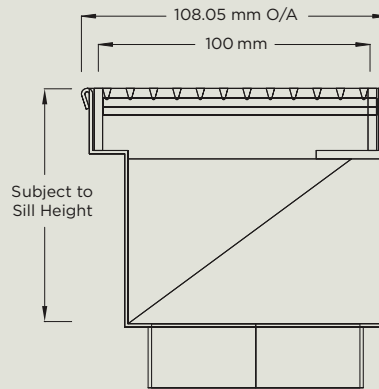

**100TDI**

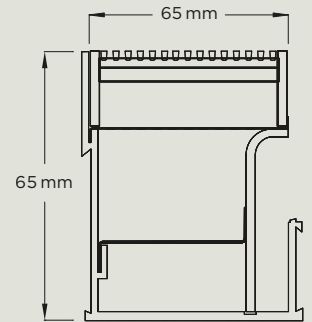

**65TDG**

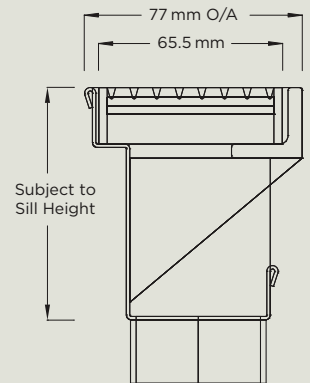

**65TDI**

## Special Assembly



The Special Assembly series has been developed for high capacity drainage needs, providing greater flexibility in landscape and pool design.

Utilising a UPVC channel connected via downpipes at 200mm intervals to sockets in the drain pipe below.

This drainage system is available in 38mm and 65mm width top channel. It is then completed with a stainless steel grate from the AR, PH or PS series, as a separate item.

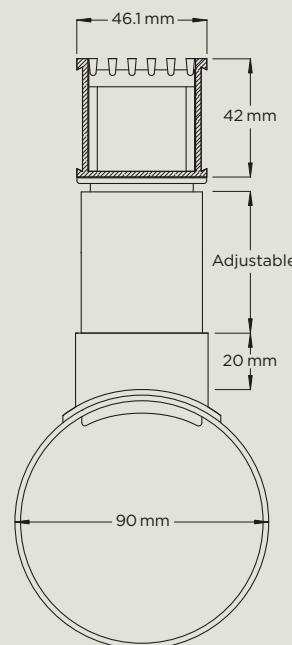

**38G90**

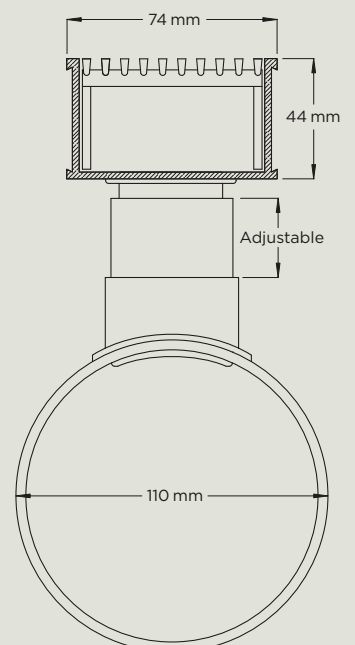

**65G100**

## Slot Drain

Ideal for stormwater run-off and surface water drainage around driveways, paved areas, sporting areas and garden edges.

The original Stormtech Slot Drain features a 25mm opening, draining into a concealed 90mm drainpipe.

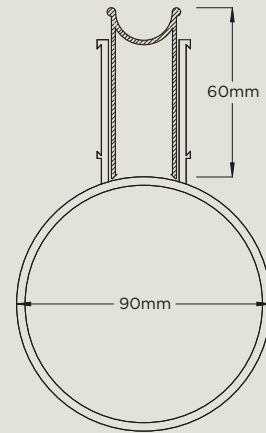

Slot Drain

## Vinyl Clamp

Allows lineal grate use in a vinyl floor environment. Suitable for hospitals, commercial kitchens, schools, etc.

Stainless steel channel and screwdown flange mechanically clamp the vinyl beneath.

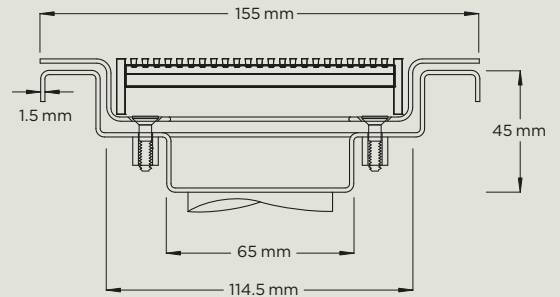

VC155-45

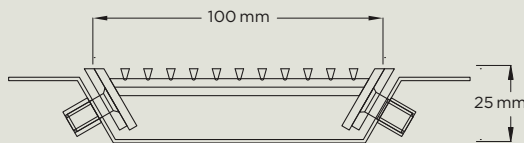

VC155-20

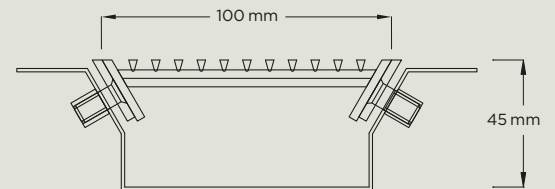

VC100-42

## Custom Design

For site specific needs or unusual situations, Stormtech can customise any drainage requirements to achieve maximum efficiency.

To create a luxurious ambience, a waterproof LED strip can be fitted to any Stormtech grate.

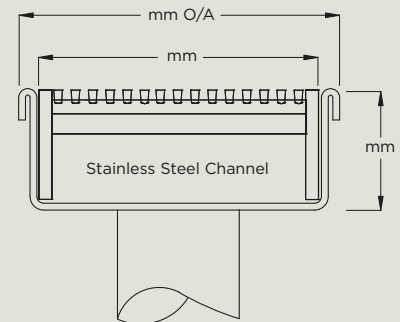

CHANNEL

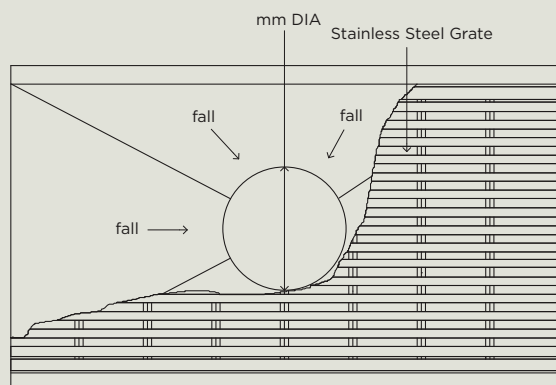

OUTLET

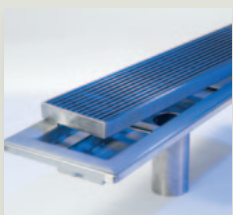
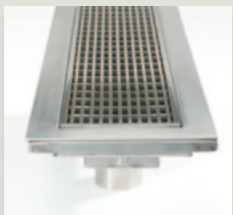
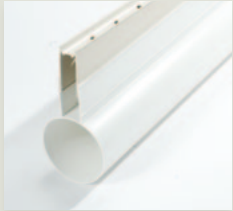

## PRODUCT DETAILS

For full product details, including assembly and installation information, visit our website.

## DISTRIBUTORS

To find a distributor near you, please visit our website or call our office.

## TECHNICAL DRAWINGS

To assist planning your project we provide complete CAD files for download from our website.

[www.stormtech.com.au](http://www.stormtech.com.au)