

# VORTX

HIGHFLOW INTEGRATED EXHAUST FAN

**V500**



## PERFORMANCE

- High static pressure far exceeding that of competitive products
- Pressure and flow rate optimised for use with ducting
- Airflow rate of 138 litres per second (496 cubic metres per hour) using a 150mm rigid duct
- Low turbulence means quieter operation and better air/vapour flow through ducting
- Unique grille designs enhance the aerodynamic performance of the fan



I N T E R N A T I O N A L

# VORTEX



HIGHFLOW INTEGRATED EXHAUST FAN

V500

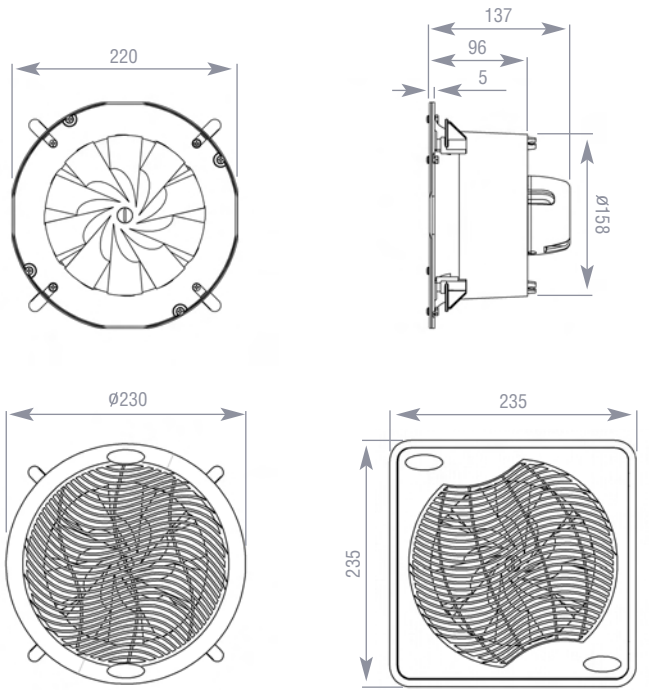

## DIMENSIONS (in mm):

**Duct Size:** 150mm

**Cutout Diameter:** 210mm

### Common External Sizings:

Motor Housing: 220 (Diameter) x 137 (Length)

Round Grille: 230 (Diameter) x 10 (Depth)

Square Grille: 235 (Height) x 235 (Width) x 13 (Depth)

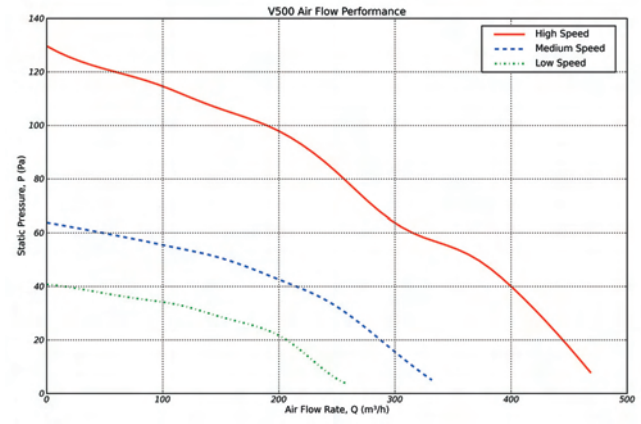

## SPECIFICATIONS

### V500 KITS AVAILABLE



ROUND GRILLE A  
[Item # 640]



ROUND GRILLE B  
[Item # 641]



SQUARE GRILLE A  
[Item # 642]

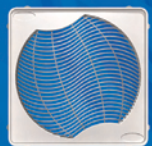

SQUARE GRILLE B  
[Item # 643]

### FEATURES:

- 3 speeds including a Boost Mode for extra fast air extraction.
- Fully sealed motor means long life, quiet operation and resistance to damage by dirt and insects.
- Aerodynamically engineered for highly efficient and quiet operation.
- Designed entirely in Australia.
- Uniquely matched design between rotor and stator ensures less turbulence and better airflow.
- Range of performance enhancing decorative grille designs.
- Grilles are easily detachable for cleaning.
- Easy installation and maintenance.
- Fan can be either wall controlled or remote controlled.
- Suitable for 150mm ducting.

PATENT PENDING

### PERFORMANCE:

- High static pressure far exceeding that of competitive products.
- Pressure and flow rate optimised for use without ducting.
- Airflow rate = 496 cubic metres per hour (using a 150mm rigid duct). This is equivalent to moving all the air in an average 2.4m x 3.6m room in 3 minutes.
- Low turbulence means quieter operation and better airflow.
- Unique grille designs enhance the aerodynamic performance of the fan.

DISTRIBUTED BY:



# VORTX

HIGHFLOW INTEGRATED EXHAUST FAN

*V500i*

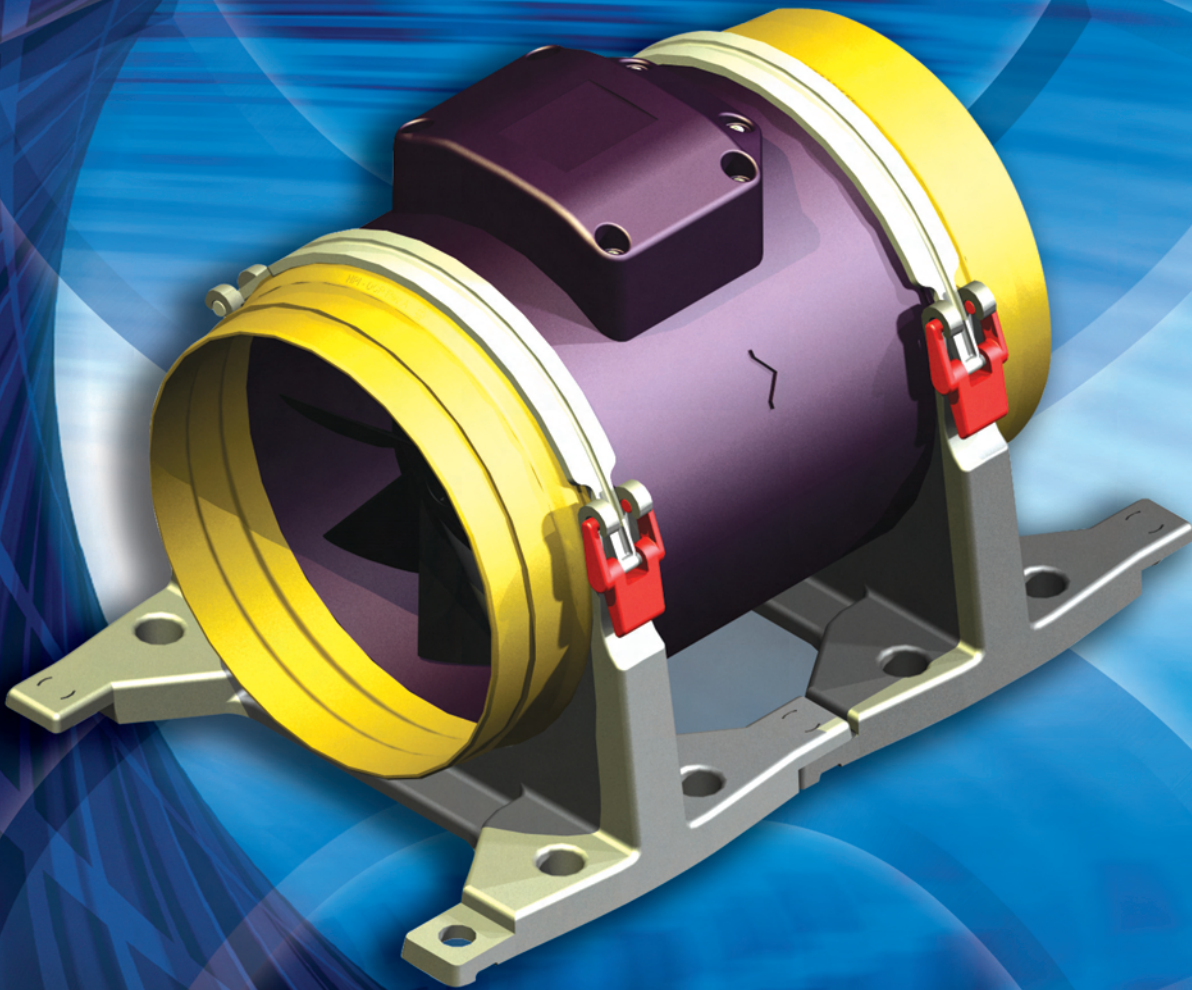

## PERFORMANCE

- High static pressure far exceeding that of competitive products
- Pressure and flow rate optimised for use with ducting
- Airflow rate of 141 litres per second (510 cubic metres per hour) using a 150mm rigid duct
- Low turbulence means quieter operation and better air/vapour flow through ducting
- Unique grille designs enhance the aerodynamic performance of the fan



I N T E R N A T I O N A L

# VORTX

HIGHFLOW INTEGRATED EXHAUST FAN

V500i

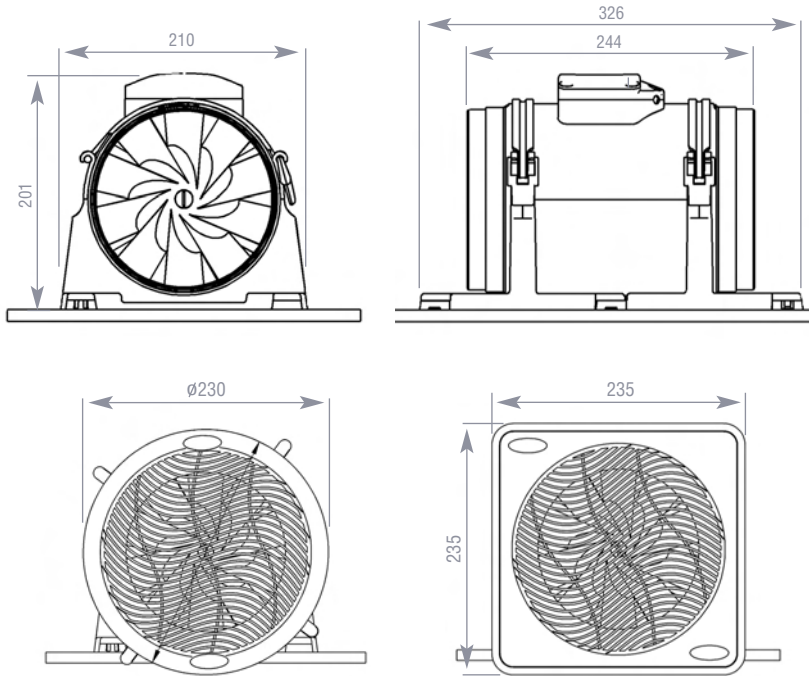

## DIMENSIONS (in mm):

**Duct Size:** 100mm / 125mm / 150mm

**Cutout Diameter:** 210mm

### Common External Sizings:

Motor Housing & Bracket: 201H x 210W x 326D

Round Grille: 230 (Diameter) x 10 (Depth)

Square Grille: 235 (Height) x 235 (Width) x 13 (Depth)

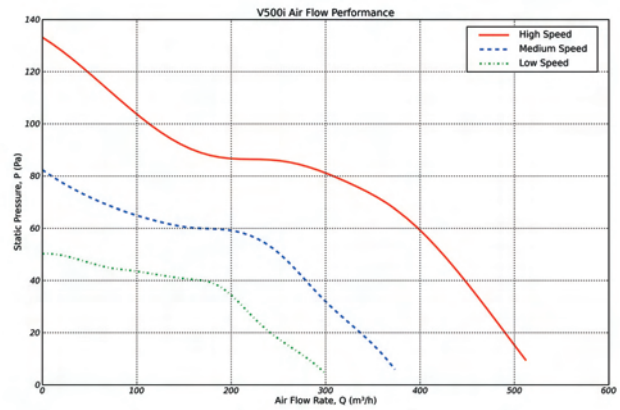

## SPECIFICATIONS

### V500i KITS AVAILABLE



ROUND GRILLE A  
(Item # 644)



ROUND GRILLE B  
(Item # 645)



SQUARE GRILLE A  
(Item # 646)

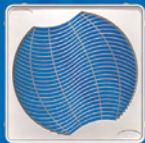

SQUARE GRILLE B  
(Item # 647)

### FEATURES:

- 3 speeds including a Boost Mode for extra fast air extraction.
- Fully sealed motor means long life, quiet operation and resistance to damage by dirt and insects.
- Aerodynamically engineered for highly efficient and quiet operation.
- Designed entirely in Australia.
- Adaptable for 3 common duct sizes.
- Uniquely matched design between rotor and stator ensures less turbulence and better flow through ducting.
- Range of performance-enhancing decorative grille designs.
- Grilles are easily detachable for cleaning.
- Easy installation and maintenance.
- Fan can be either wall controlled or remote controlled.

PATENT PENDING

### PERFORMANCE:

- High static pressure far exceeding that of competitive products.
- Pressure and flow rate optimised for use with ducting.
- Airflow rate = 510 cubic metres per hour (using a 150mm rigid duct). This is equivalent to moving all the air in an average 2.4m x 3.6m room in 2.8 minutes.
- Low turbulence means quieter operation and better flow through ducting.
- Unique grille designs enhance the aerodynamic performance of the fan.

DISTRIBUTED BY: