

MAXIBLOCK® THE SECURE CHOICE

Summer comfort, winter warmth, storm protection and reliable security in our living and work areas is becoming increasingly more important every year.

While doors and windows are vital for our everyday existence, they also present serious insulation and security problems.

For more than two decades now, Blockout Industries have provided solutions to these problems by providing a range of premium quality, insulated aluminium window shutters.

As leaders in the Australian shutter market, Blockout's high standards are maintained through careful testing by our Research and Development Team, as well as rigorous testing by independent recognised industry bodies. The University of NSW tested our shutter's insulation properties for heat, cold and noise, Schlegal Pty Ltd tested for wind loadings and water penetration and Hawker De Havilland tested the breaking strains of components especially made to combat the harsh UV rays in Australia.

Test results showed Blockout Shutters to be the strongest, most secure of its kind. Wherever the tests suggested the potential for further improvement - no matter how marginal - these improvements were made.

Our Research and Development Team continues to maintain a cutting edge by incorporating components of the very highest quality, implementing new technologies as soon as they become available and developing and refining our existing shutter designs as part of an ongoing process of improvement.

These efforts have resulted in a considerable number of advancements, one is our Maxiblock® system, which represents the ultimate in available security shutters.



Blockout Shutters are available in a choice of six standard pelmet and track colours: Federation Green, Primrose, Matt Stone Beige, Pearl White, Molasses Brown and Anodic Bronze.

Our profile selection carries thirteen colours: Bronze, Brown, Beige, Burgundy, Black, Blue, Federation Green, White, Primrose, Rivergum, Matt Stone Beige, Grey and Silver. All material is finished in either a powder coat or oven baked enamel to ensure maximum quality and longevity.

Non-standard colours are available on request to blend Blockout shutters with new or existing building exterior colours and enhance architectural and landscape design.



BLOCKOUT INDUSTRIES PTY LTD
194 NEWTON ROAD WETHERILL PARK NSW 2164
P 02 9725 3477 F 02 9725 2292

E enquiry@blockoutshutters.com.au W www.blockoutshutters.com.au



BLOCKOUT



BLOCKOUT

BLOCKOUT® SHUTTERS

MAXIBLOCK
THE SECURE CHOICE

BLOCKOUT® SHUTTERS

Extensive work by the Blockout Research and Development Team has led to the design of Blockout Maxiblock®, a registered design catering specifically for clients where security is the main priority.

Using superior components, advanced technology and the option of roll formed aluminium or extruded aluminium shutter profiles, Blockout has made the Maxiblock® range the most reliable security shutter available in Australia.

Research has shown one of the most common strategies used by would-be intruders is to attack the shutter's bottom slat and side guides (tracks). Blockout strengthened the bottom slat, making it the strongest security bar available on the Australian market. The Research and Development team also devised a new L-shaped extruded aluminium section that attaches to the security bar, making it almost impossible to bend.

As a second line of defence, Blockout developed the Maxiblock® Tracks. These tracks are deeper for more support and four times thicker than standard shutter tracks, providing greater security. A unique feature of the Maxiblock® track is that it incorporates an internal locking chamber that secures the shutter slats inside the tracks making it almost impossible to pull the slats out of position. This increases the shutter strength by nearly three times opposed to standard shutters.

Blockout's Maxiblock® also offer the optional inclusion of a secondary locking system in manually operated shutters. Located in the final slat, these locks will secure the shutter into its tracks.

The Blockout Maxiblock® range include shutters that maintain views for roofs, windows and doorways. Blockout's Maxiblock® range of shutters a high level of security while enjoying filtered light and airflow through the shutter while it is in the closed position.

The Blockout range of shutter colours and styles are unmatched by any other shutter supplier.

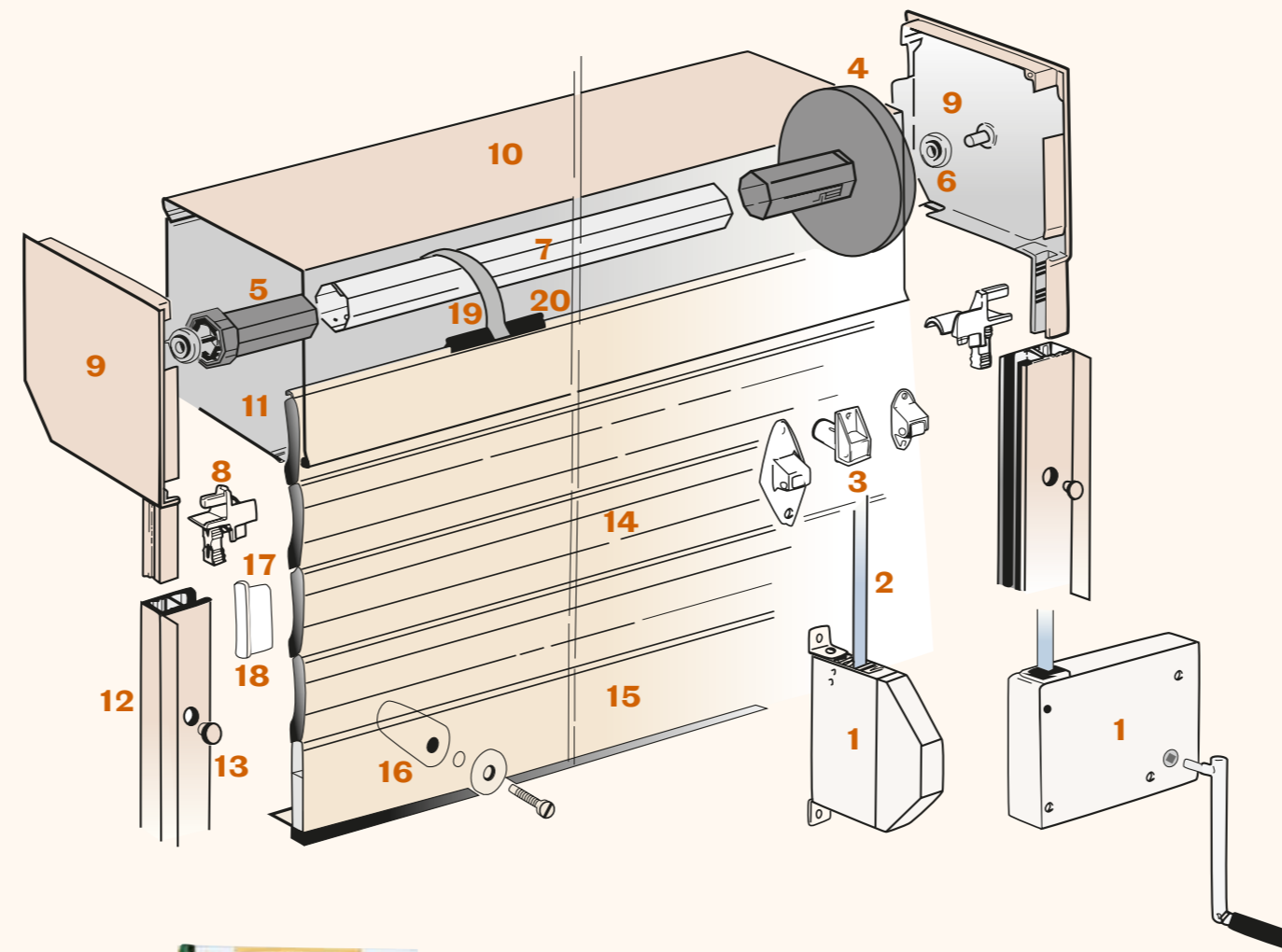

Design Certificates for Maxiblock® Shutter components

THE COMPONENTS

All components have been individually selected because they are the best of their type. They are made from high quality materials sourced from local and overseas manufacturers.

Features include:

- 1 Controls:** manual or electrically operated shutters. A choice of various manual controls or motor types and an extensive range of electronic options for both in-wall and on-wall operations. Suitable for existing buildings or those under construction. The available options are designed to match the size and weight of the chosen shutter for operational ease.
- 2 Tape and Cord Guides:** choice of guides for different fitting applications.
- 3 Tape:** manufactured especially for the Australian market with double the breaking strain of a conventional tape. The Blockout tape is made from a high tenacity polyester filament webbing that is UV stabilised to suit the Australian climate.
- 4 Pulleys:** a range of pulleys are available to suit any control operation and pelmet size.

5 Axle Caps: adjustable axle/bearing support ensuring easy access for both fitting and maintenance. Manufactured from high quality injection moulded PVC or cast aluminium.

6 Bearings: stainless steel bearings provide trouble free shutter operation. Sizes 28mm and 42mm.

7 Axles: Blockout only use galvanised round or octagonal steel axles to ensure greater reliability and rigidity. 40, 50, 60 and 70mm are available.

8 Guide Terminals: a nylon moulded insert guarantees a smooth feed for the profile between the pelmet and tracks. Available in three styles.

9 Side Frames: made from high quality pressure moulded aluminium to maintain pelmet rigidity.

10 & 11 Pelmets: manufactured from roll formed aluminium with stove enamel finish fitted into wall cavity or onto exterior wall. The two part construction provides a service access panel for easy maintenance and fitting. Blockout has the greatest range of pelmet sizes - 100, 137, 150, 165, 180, 205, 230, 250 and 300mm.

12 Track: manufactured from extruded aluminium alloy. Tracks are available in a range of ten track designs to ensure optimum support and locking for the shutter.

13 Plugs: PVC track plugs cover screw holes in cases where the shutters are fitted to the face of the wall.

14 Aluminium shutter profiles: only Blockout Shutters offer a choice of various profile designs ranging from the standard roll form

for domestic applications to the extruded aluminium profile for commercial applications requiring superior strength. Profiles are available in standard and customised colours.

15 Security bar: an extruded aluminium alloy dual locking slat provides greater rigidity and better security. Includes a dust/light and storm seal.

16 Stopper: manufactured from hard-wearing PVC to prevent overwinding the shutter.

17 End Capsules: made from injection moulded high density polyethylene. These provide a smoother rolling action and prevent potential jamming.

18 Staples: manufactured from stainless steel to ensure the end capsules are locked into position.

19 & 20 Springs: coated springs prevent scratching and form part of the locking system.

