

TOTO Eco Washer non-electric bidet seat



PRODUCT FEATURES:

- A bidet seat that operates without electricity
- Fully retractable nozzle for complete hygiene
- Simple adjustment of water pressure
- Soft Close seat and lid available
- Built in backflow prevention
- Manufactured and certified to Australian Standards

SPECIFICATIONS:

Size : 500 x 390 x 105mm (regular)
 Shipping Weight : 3kg
 Water Pressure : min.required 0.05Mpa
 max. 0.5Mpa
 Non electric
 Normal Water Temperature

Parts Description:

- **TCW-01** Eco Washer regular
- **TCW-01S** Eco Washer Soft Close
- **TCW-05 S** Eco Washer Deluxe

Colour : white only

NOTE:

Eco Washer may not fit certain toilet pan designs, please check dimensions prior to ordering; if in doubt, contact our technical staff for advice.

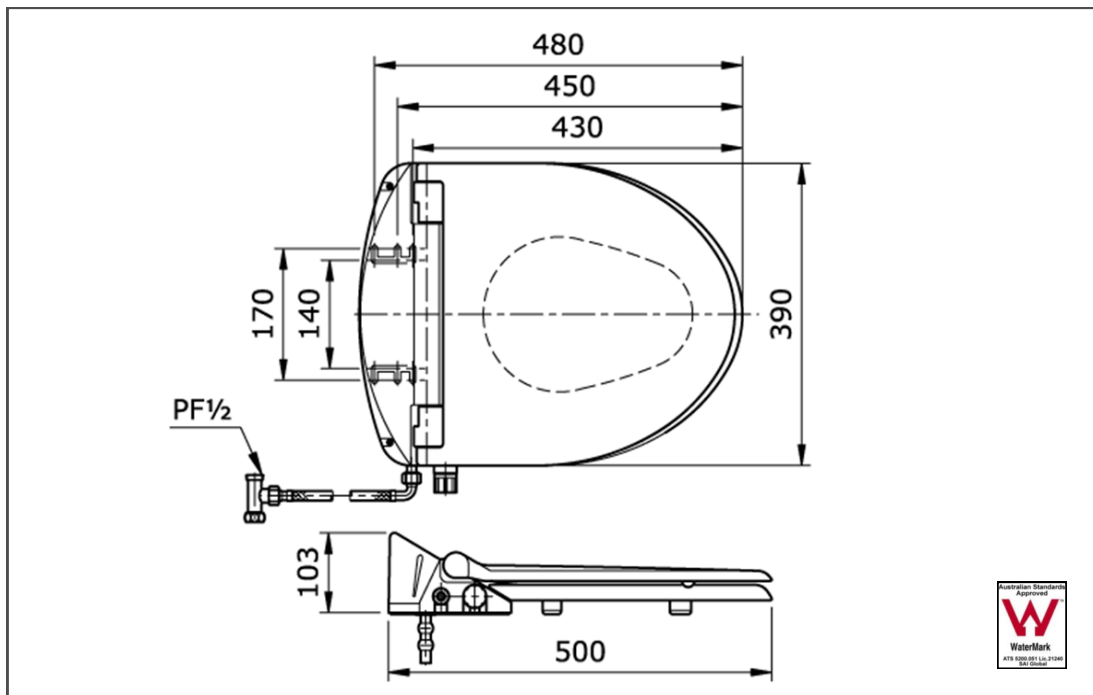

TOTO Australia Pty. Ltd.

Unit 17, 888 Bourke Street Phone: 1300 883 766
 WATERLOO NSW 2017 Fax: 02 9319 6889
 email: info@totoaustralia.com.au
 website: www.totoaustralia.com.au

NEOREST A 'P trap' one piece toilet bidet



The World's most luxurious toilet

The next generation in bathroom technology, convenience and style in a one-piece, cistern-less toilet with integrated Washlet bidet

PRODUCT FEATURES:

- New Tornado flush system, no cistern so no refill noise
- Automatic opening and closing of seat and lid
- CeFiONtect glazed pan for efficient cleaning flush
- Every Washlet feature and soft lighting
- Integral Washlet features front and rear warm water washing, auto air dryer and deodoriser
- Energy saving timer operated seat and water heater
- Smart wireless remote control
- Automatic flushing

SPECIFICATIONS:

Flush System : TORNADO Siphon-Jet (6L / 4.5L)
 Bowl Shape : Elongated
 Rough-in Height : 120 mm
 Water Pressure : min.required 0.07Mpa (flow of 20L/min)
 max.0.75Mpa
 Power : 220 – 240 V
 Cord length : 1.8 metre

PARTS:

Bowl - CS966PTA
 Washlet- TCF9683AJ
 Colour : white only

NOTE:

- Available in S trap also
- Backflow prevention built in

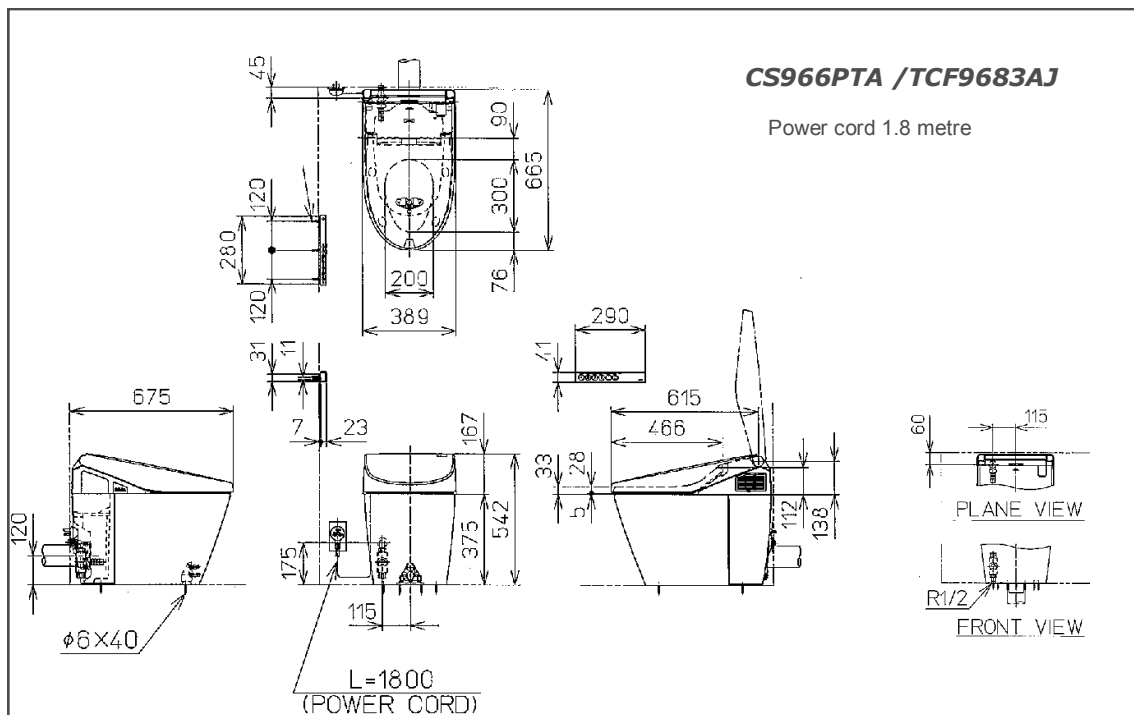

NEOREST A 'S trap' one piece toilet bidet



The World's most luxurious toilet

The next generation in bathroom technology, convenience and style in a one-piece, cistern-less toilet with integrated Washlet bidet

PRODUCT FEATURES:

- New Tornado flush system, no cistern so no refill noise
- Automatic opening and closing of seat and lid
- CeFiONtect glazed pan for efficient cleaning flush
- Every Washlet feature and soft lighting
- Integral Washlet features front and rear warm water washing, auto air dryer and deodoriser
- Energy saving timer operated seat and water heater
- Smart wireless remote control
- Automatic flushing

SPECIFICATIONS:

Flush System : TORNADO Siphon-Jet (6L / 4.5L)
 Bowl Shape : Elongated
 Rough-in : 305 mm
 Water Pressure : min.required 0.07Mpa (flow of 20L/min)
 max.0.75Mpa
 Power : 220 – 240 V
 Cord length : 1.8 metre

PARTS:

Bowl - CS966TA
 Washlet- TCF9683AJ
 Colour : white only

NOTE:

- Available in S trap only
- Backflow prevention built in
- 225mm offset floor connector available

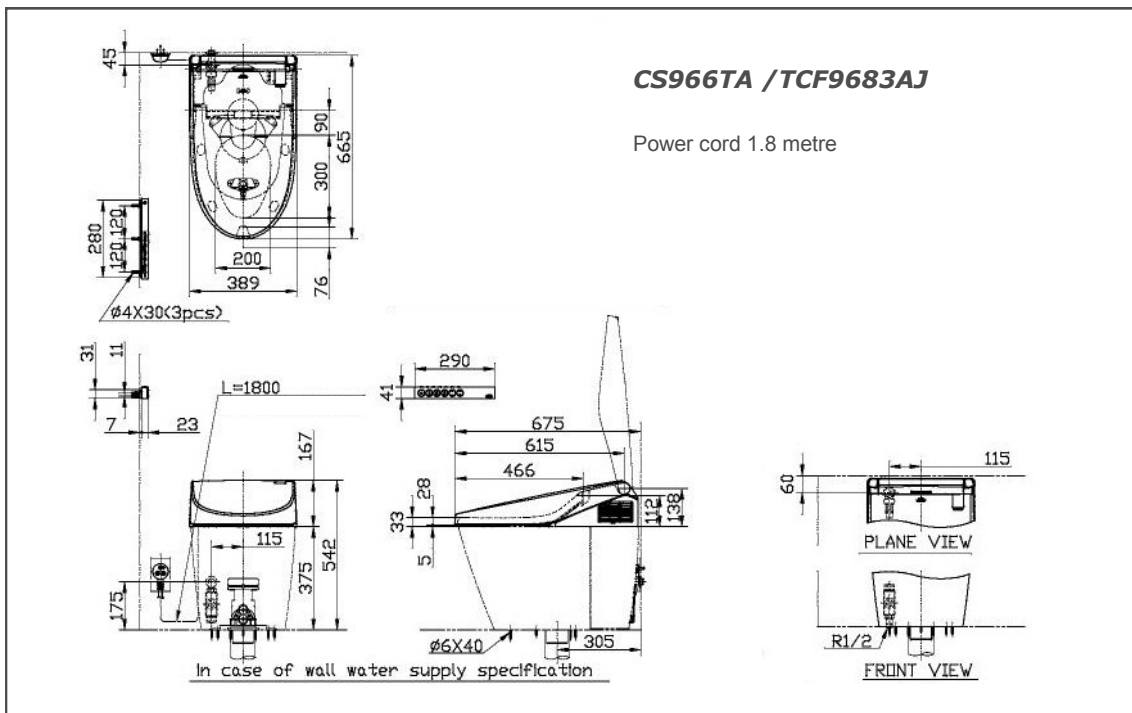

TOTO Australia Pty. Ltd.
 Unit 17, 888 Bourke Street Phone: 1300 883 766
 WATERLOO NSW 2017 Fax: 02 9319 6889
 email: info@totoaustralia.com.au
 website: www.totoaustralia.com.au

TOTO Washlet S with side control



PRODUCT FEATURES:

- Adjustable heated water front and rear washes
- Adjustable warm air drying
- Heated Seat with temperature control
- Energy saving timer operated seat and water heater
- Oscillating and pulsating comfort washes
- Soft Close seat and lid
- Manufactured and certified to Australian Standards

SPECIFICATIONS:

Size : 508 x 505 x 180mm (regular)
 Water Pressure : min.required 0.05Mpa
 max. 0.75Mpa
 Power Rating : 220 – 240V / 50Hz / 410W
 Cord length : 1.8 metre

Parts Description:

- **TCF-6230A** Washlet S regular shape
- **TCF-6231A** Washlet S elongated shape

Colour : white only

NOTE:

Washlet S may not fit certain toilet pan designs, please check dimensions prior to ordering; if in doubt, contact our technical staff for advice.

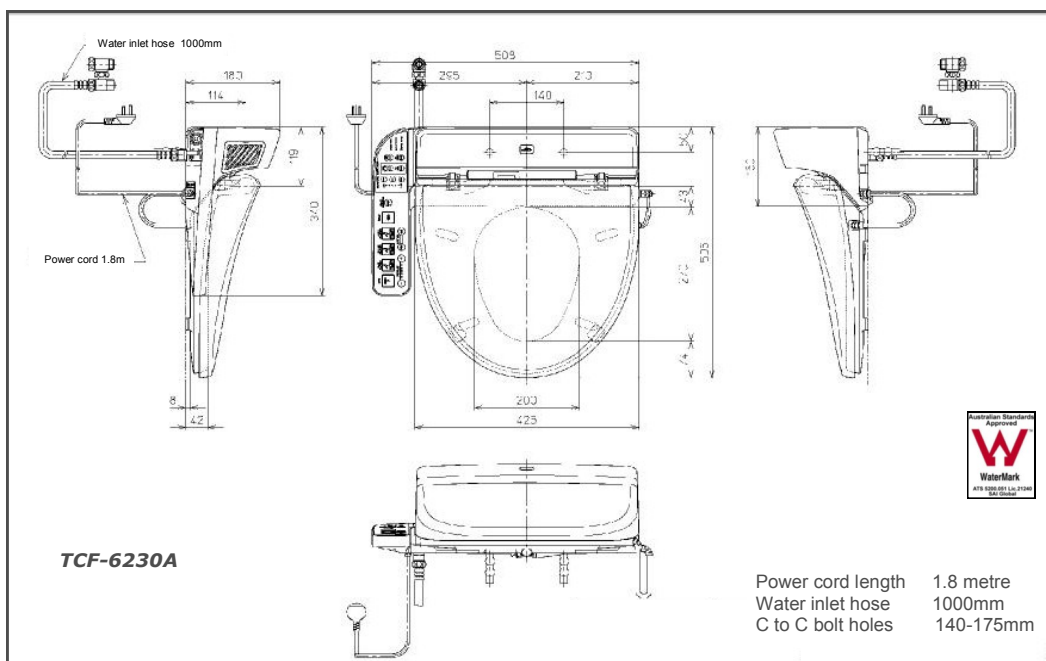

TOTO Australia Pty. Ltd.
 Unit 17, 888 Bourke Street
 WATERLOO NSW 2017
 Phone: 1300 883 766
 Fax: 02 9319 6889
 email: info@totoaustralia.com.au
 website: www.totoaustralia.com.au

TOTO Washlet SG with remote control



PRODUCT FEATURES:

- Adjustable heated water front and rear washes
- Convenient Remote Control
- Adjustable warm air drying
- Heated Seat with temperature control
- Energy saving timer operated seat and water heater
- Oscillating and pulsating comfort washes
- Soft Close seat and lid
- Manufactured and certified to Australian Standards

SPECIFICATIONS:

Size : 376 x 497 x 170 (regular)
 Water Pressure : min.required 0.05Mpa
 max. 0.75Mpa
 Power Rating : 220 – 240V / 60Hz / 410W
 Cord length : 1.8 metre

Parts Description:

- **TCF-490A** Washlet SG regular shape
- **TCF-491** Washlet SG elongated shape

Colour : white only

NOTE:

Washlet SG may not fit certain toilet pan designs, please check dimensions prior to ordering; if in doubt, contact our technical staff for advice.

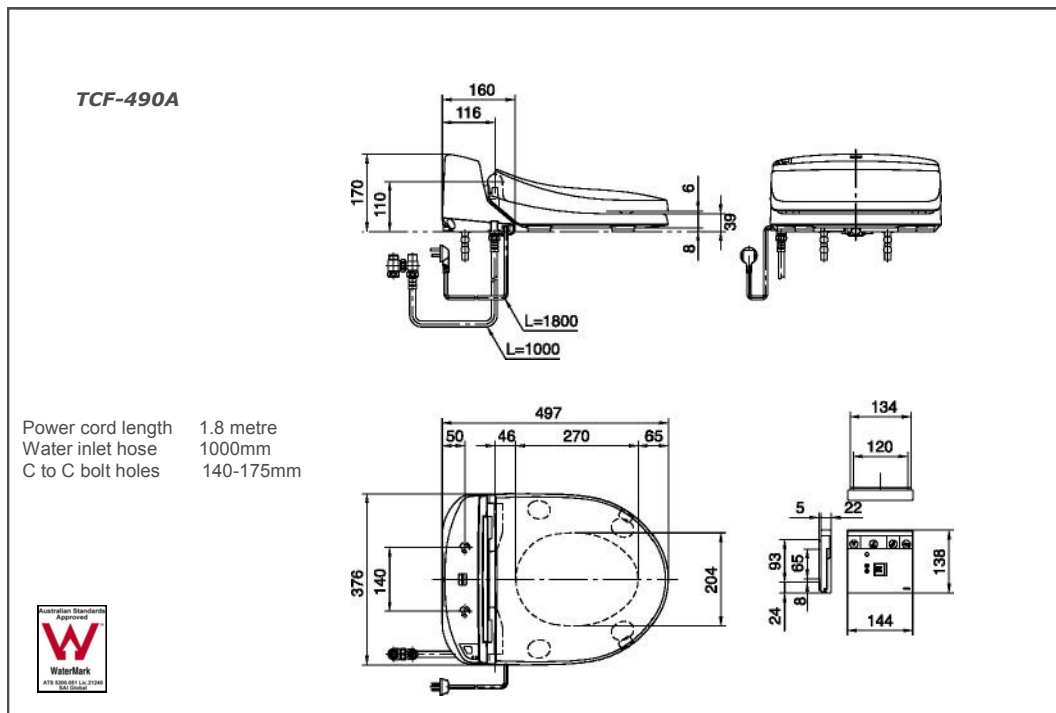

TOTO Australia Pty. Ltd.

Unit 17, 888 Bourke Street Phone: 1300 883 766
 WATERLOO NSW 2017 Fax: 02 9319 6889

email: info@totoaustralia.com.au
 website: www.totoaustralia.com.au