

July 2009

# boral plywood handbook



Boral  
Plywood







## Over A Century of Experience

Boral Plywood has a long history in the wood products industry beginning in the 1870s as the Hancock family's timber business in the mountains of south east Queensland.

The Hancock brothers began manufacturing plywood in 1935 and the company has been doing so ever since.

Today, Boral Plywood is the country's largest manufacturer of plywood panels, proudly made in Australia. With well over a century of experience, Boral plywood is produced at the company's dedicated mill in Ipswich, Queensland.

Boral is the biggest name in the Australian building products industry with operations encompassing bricks, roofing, masonry, windows, plasterboard, cement, concrete, asphalt and timber, as well as significant building products businesses in Asia and North America.





# Contents

Timber and Sustainability	2
Grading Guidelines	4
Formply Collection	5
EverForm	6
BlueForm	7
FormWood and BendiPly	8
Decorative Collection	9
Marine	9
PremierWood (formerly Exterior) and SoundWood	10
OzWood and PanelWood	11
Painting and Coating Plywood	12
Constructor's Collection	13
EverWood and BraceWood	13
LongSpan	14
UnderPly and EE Grade	16
StructuralWood	18
Infrastructure Collection	19
TrainFloor, BusFloor and TruckWood	19
EzyShield Commercial	20
BridgeDeck	22
BridgeWood	23
Outdoor Collection	24
EzyShield Suburban	24
Cladding Collection	26
Evolution Cladding	26
Plywood Cladding Installation Details	30
Pioneer Cladding	31
Frequently Asked Questions	32

## Quality Standards

Boral Plywood products are certified by the Engineered Wood Products Association of Australasia (EWPPAA) Joint Accreditation System of Australian and New Zealand (JAS-ANZ) accredited quality control program to Australian and New Zealand standards of AS/NZS 2269-2008, AS/NZS 2271-2004, AS/NZS 2272-2006 and AS 6669-2007. Boral Plywood products are manufactured under a quality management system independently audited and accredited by Bureau Veritas to ISO 9001:2008. Boral Plywood products are also certified by the EWPPAA as E<sub>0</sub> - the lowest formaldehyde emission class available.



*Australian plantation and commercial forests absorb an amount of carbon equivalent to taking 9 million cars off the road each year.<sup>1</sup>*

# Timber and Sustainability

## Timber is renewable, recyclable and sustainable.

Excess carbon gas in the earth's atmosphere contributes to the effects of climate change. Forestry is one of the best carbon sinks and long-term carbon reservoirs on the planet.

Unlike other building materials, wood can be harvested, re-grown and re-harvested in an average person's lifetime.

Furthermore, finished wood products store carbon for many decades, sometimes centuries.

Timber has one of the lowest embodied energy ratings of all building products. Compared to other common building materials, timber generates much less carbon in the production process. Other building materials such as steel and aluminium do not store carbon and can contribute significant amounts of carbon to the atmosphere during the manufacturing process.

Australian plantation and commercial forests absorb an amount of carbon equivalent to taking 9 million cars off the road each year.

**Table 1.0**

Material	Carbon released (kg/m <sup>3</sup> )	Carbon stored (kg/m <sup>3</sup> )
Timber products	15	250
Steel	5,320	0
Concrete	120	0
Aluminium	22,000	0

Forest and Wood Products Research and Development Corp, 1997. Figures indicated for guideline purposes only. The figures are a measure directly related to manufacture of material.

Australian forests are protected by strict Federal and State controls and regulations ensuring that there is a healthy balance between long term conservation and sustainable forestry management.

Only 6.3% of total Australian forests (9.4 million hectares) are available for timber harvesting each year. Of the forestry available for harvesting only 1% is harvested each year.<sup>2</sup>

When specifying for a sustainable future and a smaller carbon footprint, architects, builders and consumers should consider the following recommendations

- Consider timber products wherever possible. Together with good design, lightweight timber construction is generally a better option in terms of embodied energy and carbon storage.
- Keep in mind the impact of disposal. Of all building products, timber presents the least number of concerns when it comes to reuse or disposal.
- Choose certified, legal products.
- Specify Australian products. Australia has a world-class forestry regulatory system which can be trusted.

For further information on timber and its sustainability credentials contact Boral Plywood and ask for the Building a Sustainable Future brochure.

# Boral Plywood has full Chain of Custody certification aligned with the Australian Forestry Standard (AFS)

Boral Plywood has Australian Forestry Standard (AFS) Chain of Custody certification, the only timber certification scheme that has an Australian Standard (AS 4707-2006). This provides additional assurance that Boral's fibre and log stocks are drawn from sustainably managed forest resources.

Chain of Custody tracks a forest or wood product from its origin in a certified forest through to its end use by the consumer. The Chain of Custody certification verifies that Boral Plywood products are produced from certified, legal and sustainable resources. As such, Chain of Custody is a tracking process that provides an environmental assurance standard for the sustainable use of Australia's forest resources.

Furthermore, the two main species used in the manufacture of Boral plywood (Hoop and Slash Pine) are sourced from sustainable timber plantations managed by Forestry Plantations Queensland (FPQ) under strict environmental management systems, certified to ISO 9001-2008.

Boral is a member of the Greenhouse Challenge, a Federal government initiative linking industry and government to improve energy efficiency and reduce greenhouse gas emissions.

## What does this mean for the future?

- Chain of Custody certification AS 4707-2006 confirms that Boral Plywood products are manufactured from certified and legal sources and that the company can prove traceability of its wood materials from the forest through to its customers.
- Architects and specifiers can confidently specify Boral Plywood products on projects that require certified engineered timber, knowing that the Australian Forestry Certification Scheme is the only forest certification scheme with an Australian Standard AS 4708-2007.
- Builders can recommend Boral Plywood products knowing that they are sourced and manufactured from sustainably managed and legal resources. AFS certification covers 95% of Australian certified forestry providing confidence in an abundant supply of locally certified materials.
- Consumers and future generations can breathe easy knowing that the timber being harvested is being regrown. Increasing usage of wood products from sustainably managed forests is a positive step towards reducing the effects of climate change.
- Carbon absorption and storage by forestry and timber products play a role in positively affecting factors associated with climate change such as greenhouse gas emissions.

## The Australian Forestry Certification Scheme (AFCS)

AFCS is a forest certification scheme developed to promote sustainable forestry management specifically for the Australian environment. AFCS is mutually acknowledged by the internationally recognised Program for the Endorsement of Forestry Certification (PEFC). The AFCS is the only forest certification scheme with an Australian Standard AS4708-2007.



## Formaldehyde emissions

100% of Boral Plywood products use Phenolic Type A glue, which by nature has particularly low formaldehyde emissions of between 0.00 to 0.03 ppm or E<sub>0</sub>.



# Grading Guidelines

Boral Plywood sheeting is available in a number of grades from high quality appearance grades with limited imperfections to non-structural, non-appearance grades with no manufacturing standard. This range of options ensures the best possible veneer grades for aesthetic applications whilst allowing for significant cost savings where appearance grade is not required. Please note that the samples illustrated depict an average product representation only.



## A Veneer Face

High quality appearance grade veneer suitable for a clear finish.

Species: Hoop Pine (pruned)

Products: AA Marine, AC PremierWood (Exterior)

### Permitted Imperfections

- Filled holes:  $\leq 6\text{mm}$  across grain. Max 4/sheet
- Knots:  $\leq 4\text{mm}$  across grain. Max 4/sheet
- Pin knots:  $\leq 2\text{mm}$  across grain
- Filled splits:  $\leq 3\text{mm}$  across grain. Max 2/sheet
- Roughness: slight within area of imperfection
- Discolouration: slight natural discolouration



## B Veneer Face

Appearance grade suitable for high quality paint and stain finishes.

Species: Hoop Pine, Radiata Pine and Slash Pine

Products: Cladding, PremierWood, PanelWood

### Permitted Imperfections

- Filled holes:  $\leq 20\text{mm}$  across grain over  $500\text{mm}^2$ .
- Knots 1:  $\leq 25\text{mm}$  across grain: no limit
- Knots 2:  $>25\text{mm}$   $<40\text{mm}$ . Max 4/sheet
- Filled splits:  $\leq 3\text{mm}$  across grain: no limit\*
- Glue bleed through: no limit
- Roughness: slight within area of imperfection
- Discolouration: no limit



## C Veneer Face

Non-appearance grade with a sanded solid surface suitable for non-decorative applications.

Species: Hoop Pine, Radiata Pine and Slash Pine

Products: StructuralWood, LongSpan, OzWood

### Permitted Imperfections

- Filled holes:  $\leq 50\text{mm}$  across grain: no limit
- Knots (sound):  $\leq 50\text{mm}$  across grain: no limit
- Filled splits:  $\leq 9\text{mm}$  across grain and  $\leq 800\text{mm}$  long\*
- Glue bleed through: no limit
- Roughness: slight within area of imperfection
- Discolouration: no limit



## D Veneer Face

Unsanded, non-appearance grade with permitted open imperfections.

Species: Hoop Pine, Radiata Pine and Slash Pine

Products: StructuralWood, BraceWood, BridgeWood and BridgeDeck

### Permitted Imperfections

- Unfilled holes:  $\leq 75\text{mm}$  across grain: no limit\*
- Knots: no limit
- Open splits 1:  $\leq 15\text{mm}$  across grain and  $\leq 1/2$  sheet\*
- Open splits 2:  $\leq 25\text{mm}$  across grain and  $\leq 1/3$  sheet\*
- Glue bleed through: no limit
- Roughness: slight within area of imperfection
- Discolouration: no limit



## E Veneer Face

Non-structural, non-appearance grade with no manufacturing standard. Ideal for packaging grade applications.

Species: Hoop Pine, Radiata Pine and Slash Pine

Products: EE Grade

### Permitted Imperfections

- No manufacturing standard
- No imperfections limit.

\* Refer to AS/NZS 2269 for more information.

# Formply Collection

The Boral Plywood Formply Collection of products is designed for concrete formwork applications. This product range includes both polymer and high-density phenolic impregnated overlay sheeting and is manufactured in accordance with Australian Standard AS 6669-2007.

Available in a selection of stress grades, panel sizes and off-form finishes, the Boral Plywood Formply Collection offers the complete formwork solution for the construction industry.

## Advantages of Boral Plywood Formply products for formwork applications

- Lightweight – the weight of a typical formwork panel (1800mm x 1200mm x 17mm) is 24kg
- Reusable – when good site concreting practices are used, Boral Formply products may be reused numerous times
- Economical – Formply products are cost effective when compared to other concrete forming materials
- Flexible – panels can be easily shaped to fit applications where custom-sized panels are required



Formply

## Formply installation, storage and maintenance recommendations

- To achieve a Class 2 off-form finish in accordance with AS 3610, test panels are mandatory and should be assessed for the acceptability of grain inprint. Use EverForm if grain inprint could be an issue.
- 2mm expansion joints should be allowed with joint sealer or edge and surface tapes.
- Nailing recommendations vary depending on supports, panel size and load. In general, perimeter nailing should be used. Industry best practice is to nail 100mm in from edges at a minimum of 15mm from ends at 600mm centres or over joists.
- Use hot-dipped galvanised, stainless steel or alloy nails or screws to prevent concrete staining. Use helical thread nails for additional hold.
- Take care when using concrete vibrators, ensuring that the surface of the formwork panel is not damaged.
- Attach the formwork panel to joists to ensure tight joints and no panel movement on the frame.
- Cut or trimmed edges should be resealed with an acrylic paint to avoid moisture intake.
- Formply panels must be cleaned between uses and as soon as possible after stripping. Avoid the use of wire brushes as these can damage the surface.
- Apply a release agent before use and between uses to minimise hydration staining and grain inprint.
- Store formwork panels under cover when not in use. Avoid areas of high humidity. Do not wrap in plastic.
- Lay panels horizontally on at least three supporting bearers of equal height to prevent panel distortion.
- Plywood used as concrete formwork must comply with AS 6669-2007 Plywood-Formwork, which includes the structural requirements of AS/NZS 2269-2008.
- All concrete formwork plywood must be branded with a stress grade to AS 6669-2007, class of off-form finish and bond type.



Formply, designed for concrete formwork applications

# EverForm

Developed using the latest in polymer and adhesive technology, EverForm is Boral Plywood's premium formwork product, designed to deliver a very high quality finish with maximum durability and product reuse.

EverForm's polymer coating is lightweight, heat and chemical resistant and is designed for both conventional and panel system formwork for a finish level appropriate for visual applications. EverForm is manufactured to Australian and New Zealand Standards AS 6669-2007 and AS 3610-1995.

## Features and benefits

- Polymer coating on both sides for superior off-form finish, panel stability and long service life
- Manufactured to stress grade F27 based on 14mm (14 - 15 - 7), which is equivalent to F17 on 17mm (17 - 09 - 7)
- Available in two sheet sizes: 1800mm x 1200mm x 17mm and 2400mm x 1200mm x 17mm (other thicknesses available on request)
- Capable of producing superior finish to Class 2 off-form finish
- Provides the Class 2 lowest cost per pour at approximately 10 x Class 2 pours per side or 50 x Class 3 pours per side per panel when used with good formwork practices
- Manufactured with "A" bond Phenolic adhesive and water repellent edge sealant
- Negligible moisture uptake of less than 1.8%
- Excellent workability
- Very low chance of grain imprinting
- Can be repaired with epoxy putty or patches up to 60mm in diameter
- UV resistant
- Surface hardness rated at Shore D 75-80

**Table 2.0 - EverForm pours vs BlueForm**

Cost of Class 2 Pours	Average Purchase Price in \$/m <sup>2</sup>	Number of Class 2 Pours	Cost per Pour \$/m <sup>2</sup>
BlueForm 2400 x 1200 x 17mm	\$25.00	2	\$12.50
EverForm 2400 x 1200 x 17mm	\$55.00	20	\$2.75
<b>Reduction in Cost - 78%</b>			
Cost of Class 3 Pours	Average Purchase Price in \$/m <sup>2</sup>	Number of Class 3 Pours	Cost per Pour \$/m <sup>2</sup>
BlueForm 2400 x 1200 x 17mm	\$25.00	10	\$2.50
EverForm 2400 x 1200 x 17mm	\$55.00	100	\$0.55
<b>Reduction in Cost - 78%</b>			



EverForm deck (underside)

**Table 3.0 - Polymer coating specifications**

Surface hardness	Shore D 75-80
Nail holding properties	Good
Notch effect on crack propagation	Negligible
Resistance to UV	Average – good
Application temperature	-40 to +80°C
Removal from concrete	Good
Moisture absorption	Low <1.8%



# BlueForm

BlueForm is manufactured from a combination of sustainable plantation softwood and hardwood as a hybrid formwork panel that is lightweight while achieving a high quality finish.

BlueForm has become an industry standard formwork panel suitable in most visual applications. When used in conjunction with good concreting practices, BlueForm achieves a Class 2 or 3 off-form finish as per AS 3610-1995.

## Features and benefits

- Phenolic surface film density: 60/150gsm face and back
- Manufactured to stress grade F14 and F17
- Available in two sheet sizes: 1800mm x 1200mm x 17mm and 2400mm x 1200mm x 17mm
- Capable of producing a finish to Class 2 off-form finish on first pour per side when used in conjunction with good formwork practices and AS 6669-2007 (subject to conditions)
- Manufactured with "A" bond Phenolic adhesive and water repellent edge sealant
- Excellent workability



BlueForm in use as part of a form deck



BlueForm deck



## FormWood

FormWood has become an industry standard formwork panel for use in limited visual applications.

When used in conjunction with good concreting practices, FormWood achieves a Class 3 off-form finish in accordance with AS 3610-1995.

### Features and benefits

- Phenolic surface film density: 60/150gsm or optional 95/240gsm and softwood faces
- Manufactured to stress grade F14 and F11
- Available in standard sheet sizes 1800mm x 1200mm x 17mm and 2400mm x 1200mm x 17mm (plus a range of other thicknesses)
- Capable of producing a concreting finish to Class 3 off-form finish when used with good formwork practices
- Manufactured with "A" bond Phenolic adhesive and water repellent edge sealant
- Excellent workability



FormWood in application

## BendiPly

BendiPly is designed for use in curved formwork applications in singular or multiple layers.

BendiPly is a panel overlaid with a black Phenolic Surface Film (PSF) on one side, edge sealed with paint. BendiPly achieves a Class 3 off-form finish in accordance with AS 3610-1995 on one side only (G1S).

This product is designed for curved formwork applications in singular or multiple layers. It is ideal for challenging concrete shapes that need to have curves or radii put into the final pour shape.

### Features and benefits

- Phenolic surface film density: 60/150gsm
- Manufactured to stress grade F14
- Manufactured with "A" bond Phenolic adhesive and water repellent edge sealant
- Available in: sheet sizes 2400mm x 1200mm x 6mm, 9mm and 12mm

**Table 4.0 - Recommended minimum bending radii**

Thickness (mm)	Along Face (m)	Across Face (m)
6	1.8	1.0
9	2.3	1.3
12	3.6	2.4



# Marine

**Marine is a structural plywood, designed for use in the hulls of boats and other marine applications as well as in aircraft construction and kitchen joinery.**

Marine is a purpose built structural plywood intended for use in the hulls of boats and other marine applications. It also features in historic aircraft constructions. It has a Type A Phenolic bond and is manufactured from approved marine grade species based on density, bending strength, impact resistance and surface finishing characteristics. Boral Plywood uses Hoop Pine in all its marine plywood.

No marine species are naturally durable in water and preservative treatment of marine plywood used in exposed marine environments is a necessity.

Marine plywood actually gets the name "Marine" from the waterproof glue and the specific core veneers used in its manufacture. Contrary to popular belief, Marine plywood is not treated to H6 for marine purposes - the fibre is in fact untreated and not suitable for outdoor installation without being treated for decay prevention such as Boral's CoreTreat H3 or H4.

Marine plywood is easy to work with and on a strength-to-weight ratio it out-performs most other materials. Marine is particularly well suited for use with modern epoxy systems on polyester which provide a virtually impermeable moisture barrier and often permit more simplified construction methods.

Boral Plywood Marine has a minimum stress grading of F14 and is included in AS/NZS 2272-2006 as an engineered panel. High impact strength offers resistance to impact damage caused by rough weather and floating debris.

Boral Plywood Marine can have A Grade faces and always has a Type A bond. The AS/NZS 2272 requirements are superior to the requirements of British Marine Standard BS-1088.

Widely used in the boat building industry, Marine, with its high grade face veneer, is also used to manufacture furniture, feature walls and applications where clear

finishing is sought after to emphasise the grain of Hoop Pine and solid veneer core that is unique to Marine.

## Features and benefits

- Manufactured to stress grade F14
- Lightweight and easy to work with. Solid core with no internal core gaps
- Pruned Hoop Pine 'A' grade faces on front and back are available and are ideal for decorative applications that also require structural integrity
- 40 year warranty with a Marine bond that is heat, cold and waterproof
- Available in panel sizes: 2400mm x 1200mm and some selected 1800mm x 1200mm sheets
- Available in the following thicknesses: 4mm, 7mm, 10mm, 13mm, 16mm, 19mm, 25mm
- Marine plywood manufactured to BS1088, imported into Australia, does not have predictable structural performance and must not be substituted for AS/NZS 2272 marine plywood. For assured performance marine plywood should be branded with the 'EWPAAs Tested' marine plywood stamp



Images by Ivor Wilkins, courtesy of Alloy Yachts



## PremierWood

(Formally Exterior)

PremierWood is a high quality appearance grade plywood sheeting for interior lining applications. Previously known to the market as Exterior, the product was originally named due to the type of glue used between the sheets of veneer. The actual veneer fibre of the plywood is untreated and therefore unsuitable for installation in an exposed outdoor environment. To use this type of high grade plywood in exterior/outdoor situations requires the product to be treated with a decay resistant preservative such as Boral's CoreTreat H3 or H4.

### Features and benefits

- Manufactured to stress grade F14
- Suitable for expressed joint ceiling applications or negative detail shop fit-outs
- Has natural sound attenuation properties that can reduce ambient noise generated by sound deflections from concrete floors
- Can be slotted or drilled to provide enhanced sound attenuation properties and form part of sound wave isolation systems
- 40 year warranty with a Marine bond that is heat, cold and waterproof
- Available in panel sizes: 2400mm x 1200mm and some selected 1800mm x 1200mm sheets
- Available in the following thicknesses: 4mm, 6mm, 7mm, 9mm, 12mm, 15mm, 18mm, 25mm



PremierWood in ceiling application

## SoundWood

SoundWood is used in a variety of industrial applications where sound attenuation is important such as train floors, bus floors and linings for engine rooms in marine applications. In domestic applications, SoundWood is used for wall and ceiling linings, floors and linings for home theatres.

SoundWood is manufactured in sheet sizes of 2400mm x 1200mm to Australian and New Zealand Standard AS/NZS 2269-2008 for structural ply or AS/NZS 2272-2006 for marine ply.

Panels with a 3mm visco elastic inner layer have a STC rating of up to 30.

Acoustic treatment curved applications to a 300mm bending radius are easily achieved using 12mm thick SoundWood with kerf saw cut in the back to relieve the tension or compression (depending on whether the curve is concave or convex).

### Features and benefits

- "B" grade face and "B" grade back (B/B) or "B" grade face and "C" grade back (B/C)
- A bond with phenolic glue such as Resorcinal
- Visco-elastic layer is manufactured in three thicknesses: 3mm, 6mm or 9mm
- Rubber Visco elastic layer core covers the full panel dimension
- Suitable for curved applications
- Fire retarding can be achieved (internal only)
- 40 year warranty on lamination
- Suitable for expressed joint ceiling applications or negative detail shop fit-outs
- Premium natural sound attenuation properties that can reduce ambient noise generated by sound deflections from concrete floors
- Provides premium sound attenuation properties that can form part of a sound wave isolation system used in acoustic engineering





## OzWood

OzWood is a versatile, reliable all purpose plywood that is light, strong and has a waterproof glue bond.

It is suitable for use indoors or outdoors (with preservative treatment) in commercial, industrial and residential projects. Boral OzWood can be cut, drilled, bored, routed, planed and sanded for superior results. OzWood is manufactured with a 1.5mm thick Hoop Pine face and back veneer that may be stain finished to accentuate the Hoop Pine grain (on-site colour matching of sheets required). OzWood is manufactured in accordance with AS/NZS 2269-2008.

### Features and benefits

- 1.5mm thick Hoop Pine face and back veneer
- Available in panel sizes 2400mm x 1200mm and selected 1800mm x 1200mm sheets
- Available in the following thicknesses: 4mm, 6mm, 9mm, 12mm, 15mm, 18mm and 25mm
- Manufactured to stress grade F14 for superior stiffness



OzWood

## PanelWood

PanelWood is a quality V-grooved pine panel product that is used to create distinctive interior finishes for ceilings and walls as well as for cabinet lining and furniture making. Manufactured from Hoop Pine veneers with Radiata faces, PanelWood can also be used in structural applications, providing structural flooring or additional wall and roof bracing. The V-grooves are 3mm deep at 100mm spacings with a deeper groove on the edge profile. Thicknesses that are 10mm and thicker have a tongue and groove profile design.

### Features and benefits

- Veneer grades "B" face and "C" or "D" back
- Available in panel sizes 2400mm x 1200mm, 2700mm x 1200mm and selected 1800mm x 1200mm sheets
- Available in the following thicknesses: 7mm, 10mm, 12mm, 15mm, 17mm and 19mm
- Manufactured to stress grade F8
- Very high impact strength perfect for school halls and hospital hallways or any place that has a risk of being struck by heavy objects over the life of the building
- Economical to use in conjunction with Boral Plasterboard finishes by cutting 2400mm x 1200mm sheets in half and installing up to 1200mm high from floor level, thus protecting the base of the wall from impacts



PanelWood

# Painting and coating plywood for finished applications



Stains and matt finish paints are recommended for plywood as they achieve a quality appearance that is suitable for the substrate. High gloss finishes and paints highlight the naturally occurring features of plywood through light reflections (similar to a mirror) and are therefore not usually recommended.

Single pack polyurethane clear, in a stain or matt finish is recommended for most interior applications such as wall panelling, furniture and fittings. Single pack polyurethanes are generally resistant to heat, alcohol and household chemicals when fully encasing the plywood substrate on both faces.



Two pack polyurethanes produce an exceptionally hard, durable coating for the interior plywood surface where extreme resistance to abrasion or chemical action is required. These finishes are normally gloss. Applications such as laboratory bench tops, decks and some decorative flooring require such a finish due to scratch resistance requirements.

Acrylic polymers are fast drying and should not be rubbed down between coats. They should be non-yellowing through the inclusion of ultraviolet filters. Do not expose such a finish to direct heat or sunlight as in bay windows, conservatories or bench tops.

Oil based stains have been used for over 100 years and are still successful in giving a consistent finish for the home handyman. Professionals tend to use spirit based stains but experience is required to use spirit based stains with success in terms of surface finish. Oil based stains are best for the person not familiar with working with plywood.



With all finishes, raw sheet colour matching prior to installation is required on-site to achieve industry best practice installations.





# Constructor's Collection

This group of high quality plywood products is designed for a multitude of common lightweight construction applications including all-purpose heavy duty plywood sheeting, commercial plywood flooring, bracing and underlays. These products carry a 40 year structural warranty.

## EverWood

EverWood is a preservative-treated all-purpose heavy duty plywood sheeting for structural applications in harsh environments.

EverWood is treated with CoreTreat to H3 or H4 Hazard Levels. H3 is backed with Boral's 40 year warranty against fungus and termite attack, while H4 is covered for 50 years.

### Features and benefits

- Available in panel sizes 2400mm x 1200mm, 2700mm x 1200mm and some selected 1800mm x 1200mm sheets
- Available in the following thicknesses: 7mm, 9mm, 10mm, 12mm, 15mm, 17mm, 19mm, 21mm, 25mm and 33mm
- Manufactured to stress grade F14 for superior stiffness or F8 for more general applications
- Perfect for trailer or truck decks
- Used in wet area home renovations to replace particleboard (laundry, kitchen and bathroom)

## BraceWood

BraceWood is a traditional plywood product manufactured in three-ply 7mm sheets for a broad range of applications.

BraceWood is a sought-after plywood product for its general bracing units. It is manufactured to Australian and New Zealand Standards AS/NZS 2269-2008. BraceWood is manufactured with a cross-laminate structure that maintains two-way dimensional stability under changes in temperature and moisture content.

### Features and benefits

- 40 year warranty on lamination with a Phenolic 'A' bond that is heat, cold and waterproof
- Can withstand 6.4kN/m bracing capacity, provided the correct nailing pattern is used. Refer to Figure 6.0 on page 28. Also see the EWPA Structural Plywood Wall Bracing - Limit State Design Manual for further instructions. Visit [www.ewp.asn.au](http://www.ewp.asn.au) to download this manual
- Can be glue line treated to H2 Hazard Level with no odour or handling residue
- Can be nailed up to 10mm of the edge and will still hold nail or screw fixings

# LongSpan

LongSpan is a tongue and groove structural plywood panel designed as a complete flooring system for wet and dry areas in domestic, commercial and industrial flooring applications.

LongSpan is manufactured to Australian and New Zealand Standard AS/NZS 2269-2008 from plantation timber veneers with a type A bond.

LongSpan gains its name from its superior spanning capability between joists due to its F14 strength and stiffness rating. Unlike uncertified particleboard flooring, LongSpan emits virtually no formaldehyde vapour ( $E_0$ ), less in fact than the amount of formaldehyde found naturally occurring in the air\*. Boral Plywood LongSpan is certified by the Engineered Wood Products Association of Australasia Association as being  $E_0$  - in the lowest formaldehyde emission class available.

LongSpan is designed for flooring applications such as industrial and commercial floors, storage decks and sports floors. For floors or roofs that require extra protection from fungus and insect attack or that may be flooded during the service life of the floor/roof (membrane roofs, bathrooms, kitchens and laundries) LongSpan is available with CoreTreat H3 that carries a 40 year anti-rot warranty.



## Features and benefits

- 40 year warranty on lamination with a Phenolic 'A' type bond that is heat, cold and waterproof
- Will not release formaldehyde over service life, even if underfloor heating is installed, unlike some other common flooring panels
- Superior F14 strength and stiffness, yet lightweight and easy to install
- Able to be scarf jointed in one piece sections, up to 12m in length
- Can be nailed up to 10mm from edge and will still hold nail or screw fixings
- Compared to particleboard, LongSpan plywood sheeting is thinner and lighter for the same application
- Excellent elastic recovery after bearing very high loads
- Dimensionally stable and when installed correctly, has better squeak resistance properties than particleboard panels due to higher stiffness at the same thickness
- Can be used with similar thickness particleboard floors in specific wet areas of the home (bathroom, kitchen and laundry), providing a total floor, cost effective solution
- Easy to drill, saw and nail and has a full length plastic, removable tongue
- Typically 120m<sup>2</sup> can be laid by two people in approximately two hours, providing a sturdy platform for the remainder of construction

*LongSpan is designed for flooring applications such as commercial floors, storage decks and sports floors.*

## LongSpan installation and storage recommendations

- The LongSpan sheet should be laid face up with the LongSpan label on the back of the panel laid down.
- The face grain of a LongSpan panel must run parallel to the span, at right angles to the joists in brickbond fashion.
- End sheet butt joints must be fixed over a joist for best dimensional stability and should be staggered so as not to cluster over one joist.
- 2-3mm expansion gaps should be allowed at the end of each sheet to allow for natural expansion and contraction.
- Before laying each sheet, a bead of appropriate structural flooring adhesive should be applied to each joist.
- In wet areas, panels should be sealed and treated with CoreTreat (H3). Please refer to the EWPAAs flooring manual (available at [www.ewp.asn.au](http://www.ewp.asn.au)) for further information on the correct sealing of plywood panels for wet areas.
- When laying sheets in wet areas, a bead of appropriate flooring adhesive should be applied along the top of each tongue.
- See Table 5.0 for recommended fixings.
- LongSpan should be fixed at 150mm centres on panel end joists and at 300mm centres along intermediate joists.

**Table 5.0 - Residential LongSpan (UDL 1.5kPa and CL KN)**

Standard Joist Spacing (mm)	LongSpan (F14) Thickness (mm)
400	12
540	15
600	17
660	19
710	21
800	25

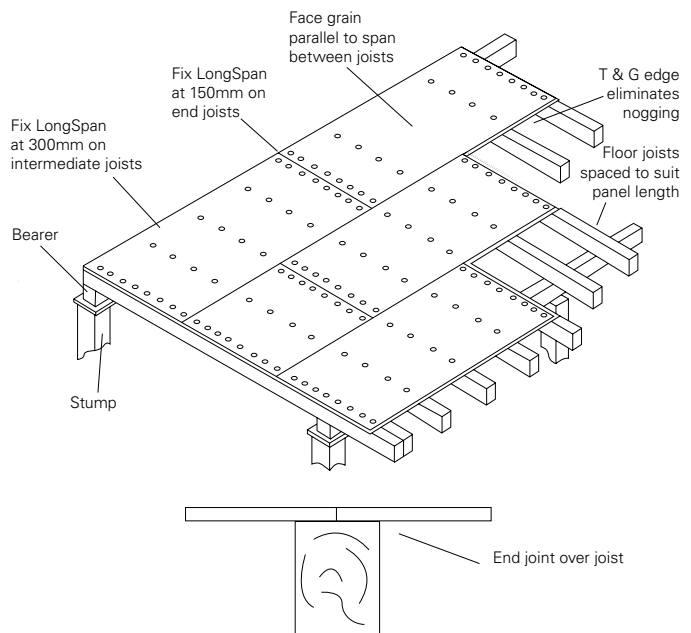

### Minimum Fixing Specifications

Hand driven nails	2.8 min diameter flathead or bullet head nails of length at least 2.5 times the LongSpan thickness
Gun driven nails	2.5 min diameter gun nails of length at least 2.5 times the LongSpan thickness
Screws to timber joists	No. 8x30 self drilling countersunk wood screws (no. 8x40 for 25mm LongSpan)
Screws to steel joists	No. 10x40 countersunk self drilling to metal screws (No. 10x50 for 25mm LongSpan)



LongSpan





# UnderPly

UnderPly is specifically designed as a substrate for high quality flooring applications such as hardwood timber flooring

UnderPly is manufactured to Australian and New Zealand Standards AS/NZS 2269-2008. It is designed for use as an underlay for flooring such as Boral Timber's parquetry or 19mm solid strip flooring and as non-structural underlay for Boral Silkwood engineered flooring and 13mm solid strip flooring.

UnderPly provides a sound substrate upon which to float, glue or nail floor boards or glue parquetry over existing timber strip floors or concrete slabs.

UnderPly is easy to install and acts as a moisture barrier to isolate the hardwood floor from the moisture inherent in concrete slabs. UnderPly has a waterproof phenolic 'A' bond which further assists in protecting a decorative timber floor.

It can also be used as a structural floor when fixed over traditional floor joists. UnderPly should be 15mm thick over joists at 450mm centres and 17mm thick over joists at 600mm centres. It can be worked with conventional wood working machinery and hand tools and can be nailed or screwed.

## Features and benefits

- 40 year warranty on lamination with a Phenolic 'A' bond that is heat, cold and waterproof
- UnderPly is manufactured to F14 or F8 stress grade so it is less likely to develop substrate interaction noise when compared to weaker products with no F rating
- Underply is rated at E<sub>0</sub> for formaldehyde emissions (lowest rating possible) and is not affected when under stress of heat, cold or water such as a floor flood in a wet area of a home
- Economical to use
- Provides a stable substrate that will not delaminate, buckle or bow. A tongue and groove strip floor can be placed onto UnderPly with confidence

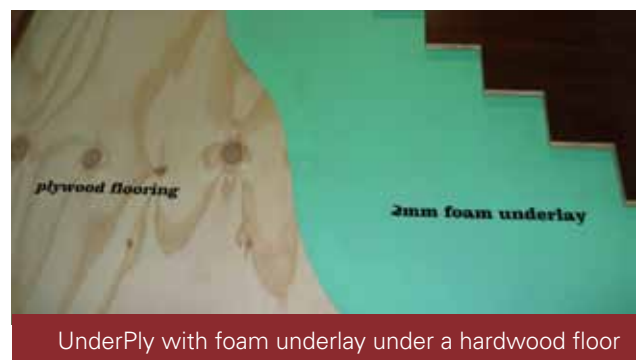

## Specifications

Dimensions: 2400mm or 2700mm x 1200mm

Thickness: 12mm, 15mm, 17mm, 19mm and 25mm

Stress Grade: F14 and F8

Average density: 620kg/m<sup>3</sup>

## Handy hints

- It is important that UnderPly is acclimatised on site for a minimum of seven days. Acclimatisation should continue until the installer verifies by use of a suitable moisture meter that the timber has come to an "equilibrium moisture content" which is appropriate for the installation. Ensure the moisture variation between the UnderPly and the flooring is limited to no greater than 2% during application.



UnderPly used as a substrate for hardwood flooring

- When laying flooring over UnderPly, strip-out the adhesive at 450mm centres and at right angles to the board or alternatively completely cover the panel with adhesive.
- Use the Boral Timber Flooring Installation Guide when installing Boral Timber flooring products.

#### Floor coverings and fixing methods

- Boral 19mm solid strip flooring - strip glue at 450mm centres and secret nail.
- Boral 13mm solid strip flooring - glue down with flooring adhesive as per manufacturer's instructions.
- Boral block parquetry - glue down with an appropriate flooring adhesive as per manufacturer's instructions.
- Boral Silkwood hardwood engineered flooring - float or glue over foam underlay such as Boral RV-4.
- Vinyl tiles or sheeting - glue down with vinyl adhesive.
- Cork tiles or sheeting - glue down with cork adhesive.
- Carpet - glue down and nail.

#### Fixing to concrete slabs

- Concrete slab should be well cured and below 5.5% moisture content, clean with a dry surface.
- Check the subfloor for level.  $\pm 3\text{mm}$  within a 3m radius is necessary for a level of plane.
- Lay a polythene membrane, minimum 200 micron. Overlap all joins by 200mm and seal with duct tape. Continue membrane 75mm up walls and trim later.
- Lay UnderPly in a brickbond pattern as illustrated in Figure 1.0, with a 3mm gap between the sheets and 10mm gap between the UnderPly and wall plates.
- At the predetermined fixing location holes, UnderPly should be counter bored with a 16mm spade bit to recess the anchor heads.
- Use nylon impact type masonry anchors or similar appropriate concrete fasteners for fixing UnderPly to subfloor. Holes should be pre-drilled and located at 365mm (width) and 460mm (length) centres with perimeter fixings 50mm in from the edge, 24 per sheet in total (on 2400mm x 1200mm sheet).
- This method is suitable for fixing tongue and groove flooring using the secret nailing method but is not suitable for top nailing. AS1684 states the minimum length of nails used should be 2.5 times the thickness of the boards. Therefore when 19mm flooring is top nailed, 70 x 35mm gauged kiln dried hardwood battens should be used to give adequate nail penetration.
- Boral does not recommend the use of power fixings as they may work loose over time.

#### Fixing to existing timber floors

- When fixing UnderPly over ventilated tongue and groove timber strip flooring, a moisture barrier is not required and fixings employed are usually staples or nails. Otherwise the method is similar to that outlined for concrete.

#### Fixing over bearers and joists

- UnderPly can also be used over bearers and joists to provide a structural subfloor. Check span tables for joist spacing and appropriate UnderPly thickness.
- Ensure panels are laid perpendicular to joists and panel rows are staggered at one joist space difference.

**Figure 1.0 - UnderPly laid perpendicular to joists plus nailing pattern**

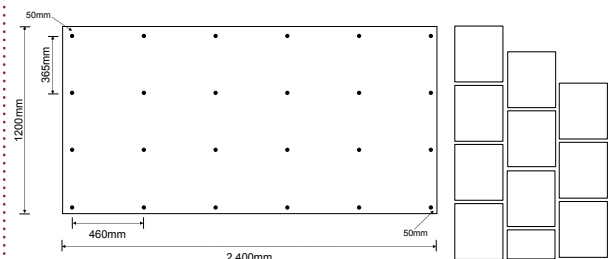

#### EE Grade

Boral offers a plywood sheeting option for when appearance is not important but nail holding and low product cost is.

EE Grade is a non-structural plywood sheeting product that offers a cost-effective option specifically for the materials handling sector or under hardwood floors. With a low grade aesthetic appearance, EE Grade has no Engineered Wood Product Association of Australasia (EWPA) warranties.

EE grade is made from Slash, Radiata or Hoop Pine and is perfect for packaging or materials handling applications due to the following features

- Unsanded - good for glue bonding as required in pallets
- In-square-sheets
- Available in a wide range of thicknesses consistent with Australian made supply of plywood product
- No warranty on the glue bond between the veneers

# StructuralWood

StructuralWood is an industry standard for general purpose plywood. It is sought after for consistent and known flatness, squareness and thickness with the confidence of a 40 year lamination warranty.

StructuralWood is structural plywood sheeting manufactured to AS/NZS 2269-2008 and is recognised as an engineered panel under AS 1720. It is designed for most structural applications such as shelving, strip flooring underlay, marine, fitout stages, truck bodies and industrial flooring where visual appearance is not of major importance, but lamination and strength are critical. StructuralWood is manufactured with a cross-laminate structure that maintains two-way dimensional stability under changes in temperature and moisture content.

Fibreglass overlays are directly compatible with StructuralWood and relatively simple to apply. They have many end use possibilities such as tanks for storing chemicals and liquids, linings for bins where smoothness is a requirement and waterproofing structures like boats, residential decks or industrial trafficable and non trafficable roofs.

StructuralWood plywood usually has a thicker face veneer than those used in concrete formwork plywood or marine plywood. StructuralWood transfers load in all directions, however because of the veneer arrangement, most structural plywood has greater strength and stiffness in the face grain direction. It is specified that structural plywood be supported such that the face grain is parallel to the span. Supporting plywood with the face grain direction at right angles to the span is not recommended. (Note: the face grain direction of plywood normally runs parallel to the length of the plywood sheet).

## Features and benefits

- 40 year warranty on lamination with a Phenolic 'A' bond that is heat, cold and waterproof
- F8 or F14 sheet stiffness along the grain
- Scarf jointing in one piece sections, up to 12 metres in length
- Can be nailed up to 10mm from the edge and will still hold nail or screw fixings
- Can be treated to H2 with glue-line additive that is odourless and no has residue



StructuralWood in a retail fitout application



StructuralWood in a commercial theatre application



# Infrastructure Collection

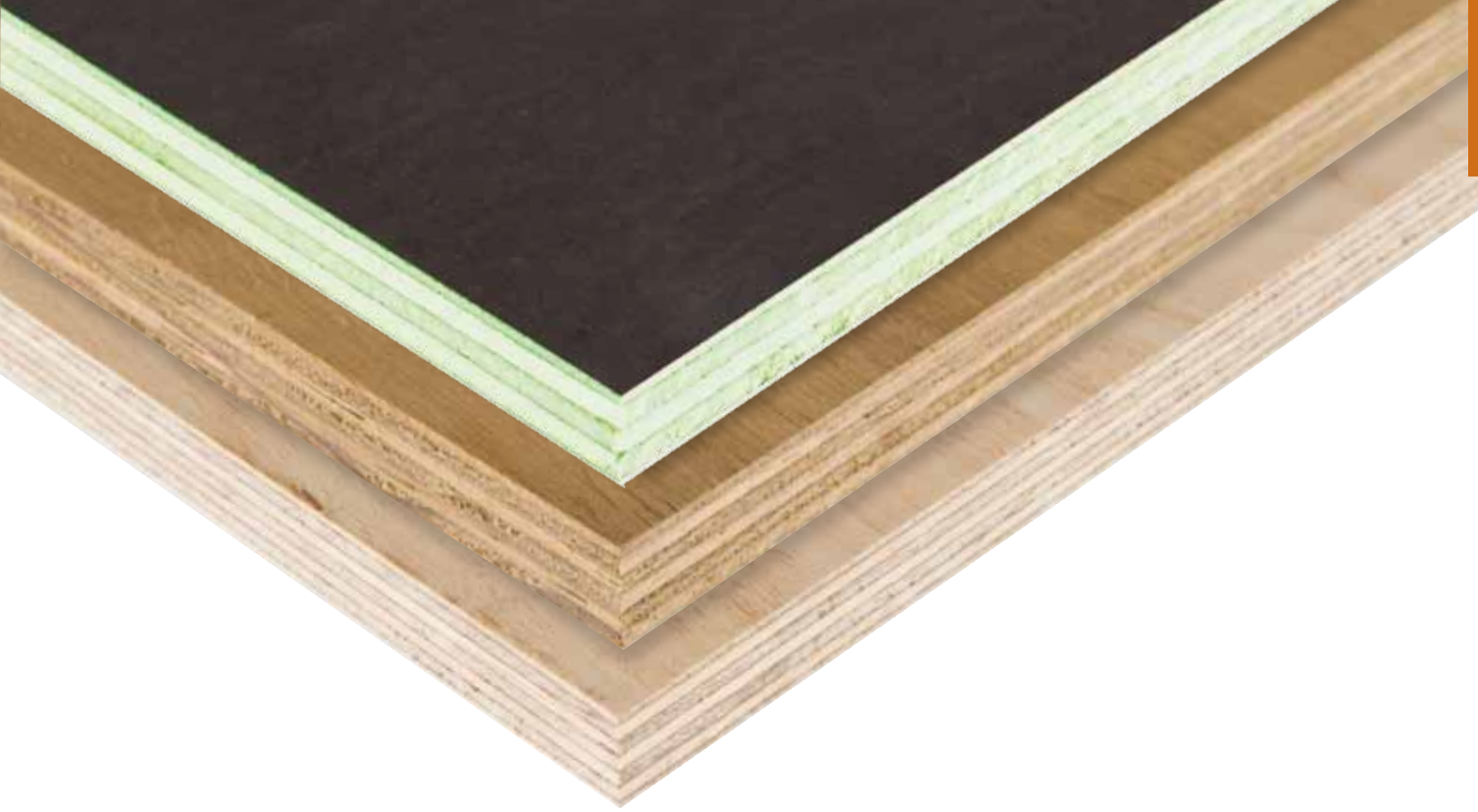

*Plywood panels specifically designed for transport applications*

## TrainFloor

TrainFloor is a specialist product manufactured specifically for train floors in suburban train carriages and locomotive engines. It can be overlaid with resin coated paper and is also available with a fire retardant coating.

When TrainFloor is treated with CoreTreat H3 it carries a decay resistance warranty of 40 years.

Boral Plywood manufactures lengths of up to 12 metres as one sheet and thicknesses of up to 38mm.

TrainFloor is manufactured to a minimum of stress grade F14 and up to F22 for superior stiffness and strength as required by high load and transport applications such as the railway industry.

## BusFloor

BusFloor is a specialist product manufactured specifically for bus floors in suburban buses and coaches. It can be overlaid with resin coated paper and is available with a fire retardant coating.

Due to bus cleaning requirements that use large amounts of water, BusFloor is treated with CoreTreat to H3 with a 40 year warranty against decay.

Boral Plywood manufactures lengths of up to 12 metres and thicknesses of up to 25mm. BusFloor is manufactured to stress grade F17 or F14 for maximum strength and spanning capacity to minimise chassis weight.

## TruckWood

TruckWood is another specialty product designed for motor bodies or any automotive application that requires a substrate flooring or wall for fibreglass coating. TruckWood has a unique finish that will allow appropriate keying for fibreglass applications and is manufactured with a plywood tongue and groove profile. This profile limits movement within the motor body wall as required by long haul truck applications where constant movement is the norm. For strong yet light weight applications, TruckWood is manufactured to stress grade F14 in 1200mm wide panels, scarf jointed to lengths of up to 12 metres.

# EzyShield Commercial

EzyShield Commercial is used as a visual and noise barrier for freeways, commercial developments and housing estates. It is specifically designed for commercial applications, with a unique production process ensuring long-term durability.

EzyShield Commercial is a robust panel machined with a weather-enduring profile and manufactured to AS/NZS 2269-2008. EzyShield Commercial has been pioneered and developed by Boral Plywood over the last 20 years and is part of some of the nation's biggest infrastructure projects such as Melbourne's Eastlink, the Pacific Highway from Brisbane to Surfers Paradise and many train corridors through Australia. The product is designed to meet the needs of shielding home owners and pedestrians from road or rail noise nuisances. It can be built over 6 metres high and being light, compared to stone or concrete, can be installed in difficult terrain or sensitive sites. As a modular system the EzyShield Commercial fence solution can be easily modified at minimal cost should the requirements for noise abatement change in particular installations.

## Features and benefits

- Lightweight and easy to install with a tongue and groove joining system
- Very high acoustic performance: up to 30dB reduction, depending on sound generation conditions
- Available in CoreTreat or CCA treatment against termites and fungus to H3 or H4 Hazard Level
- Supplied with a 40 year warranty against glue failure
- Offers a broad design scope and can be used in conjunction with other building materials
- Offers up to STC 24 for 24mm and STC 28 for 33mm (NAL Report AFT480 and AFT481 respectively)



EzyShield Commercial used in a freeway application



EzyShield Commercial used in a freeway application

**Sheet Sizes**

EzyShield is available in the following sizes with other sizes available on request.

- Thickness: 24mm, 27mm and 33mm
- Width: 1200mm (cut to size 600mm / 400mm)
- Length: 2400mm and 2700mm

Boral Plywood recommends consulting a fencing installer or suitable engineer to determine the correct thickness to use. A suitable soil report should also be obtained before designing the fence.

**Enduring Profile**

EzyShield is manufactured with a rippled profile designed to control climatic weathering that may occur over time. To increase the stability of the EzyShield Commercial fence, timber battens fixed in the middle of the sheets or bays are recommended.

**Sound Transmission Class (STC)**

The National Acoustic Laboratories measured the acoustic transmission loss of two thicknesses of EzyShield and obtained the ratings shown below

- EzyShield 24mm 14kg/m<sup>2</sup> - STC24\*
- EzyShield 33mm 18kg/m<sup>2</sup> - STC28\*

\*National Acoustic Laboratories Reports AFT480 and AFT481 respectively

**Jointing**

A tongue and groove joining system is used to couple panel edges, giving a strong, warp resistant structure.

**Design Freedom**

Steel, timber or concrete posts may be used. Panels are usually installed horizontally due to their cross dimensional stability therefore requiring fewer posts. It should be noted that fences over 2000mm in height should only be installed on steel posts (Galvanised UBs) using non-direct fixing method. See Figure 2.0.

Some popular design options combine glass or acrylic clear panels and steel, allowing highways, roads, pedestrian walkways and cycle ways to be safer with more light and less chance of vandalism.

**Figure 2.0**

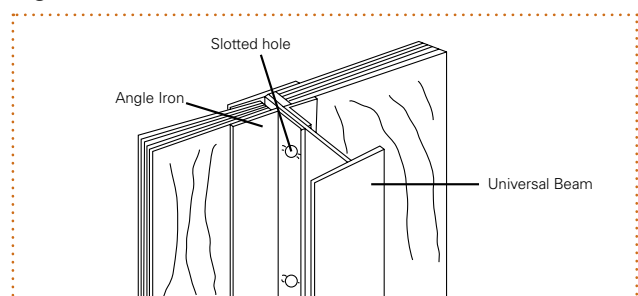





# BridgeDeck

BridgeDeck is a structural grade plywood, specifically developed for bridge decks, wharf platforms, highways, footbridges and walkways as an alternative to solid hardwood members.

BridgeDeck was developed in response to the shortage of suitable lengths of solid hardwood timber for bridge decking. A structural plywood, BridgeDeck is manufactured to AS/NZS 2269-2008 from Australian plantation grown pine. Cross laminated, the panels range in thickness, length and width to offer engineers flexibility in design. BridgeDeck is treated to ensure preservation from environmental elements.

It has a minimum stress grading of F14 and has the ability to absorb shocks and will recover to its original position once the load is reduced.

## Features and benefits

- Manufactured to a minimum stress grade of F14
- Can be cantilevered to widen bridges
- Can be used with a variety of support structures
- Is treated for termites and fungus with CoreTreat with up to a 50 year warranty on treatment (H4)
- Has a service life expectancy of 40 years (H3) or 50 years (H4) with CoreTreat
- Can be used above marine (salt) environments



BridgeDeck



BridgeDeck in application with Boral Plywood Girders

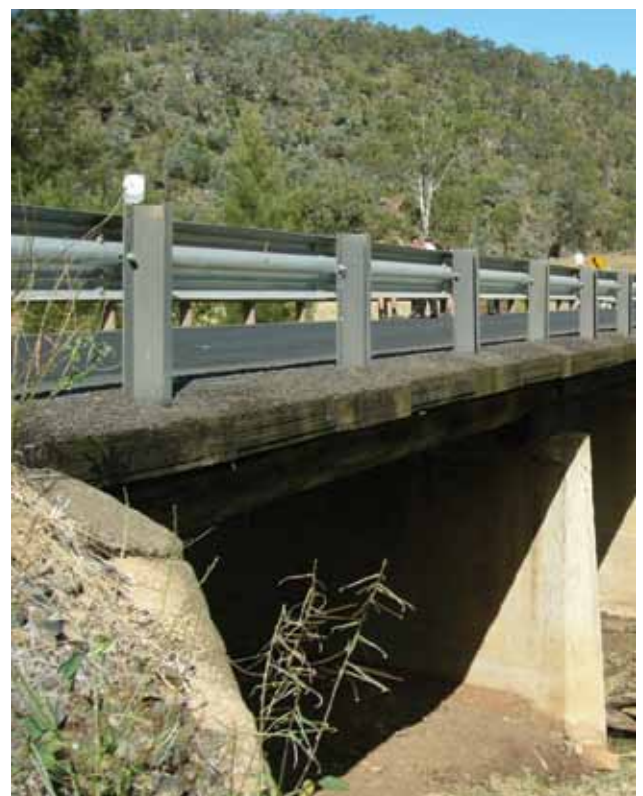

Completed BridgeDeck project

# BridgeWood

BridgeWood is a structural grade plywood-based product specifically designed to carry T44 loads or AS5100 loadings and encompasses whole modular bridges, footbridges, girders and walkways as an alternative to traditional timber, steel and precast concrete.

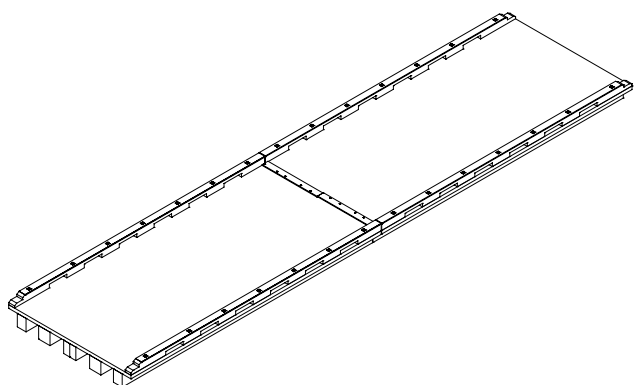

BridgeWood is manufactured from Australian plantation timber to AS/NZS 2269-2008 and uses a proven adhesive system that will not perish under Australian climatic conditions.

Specifically designed for each application, BridgeWood has excellent shock absorbency properties.

BridgeWood is not subject to the fatigue failure of crystalline metals or plastics. It will retain its strength regardless of age and has a service life expectancy of over 50 years when correctly installed and maintained.

Boral Plywood has recently added the Modular Bridge system to the BridgeWood product range, making the construction and refurbishment of existing timber bridges both fast and cost effective.

BridgeWood Modular Bridges are manufactured up to 15m x 2.7m in size, preassembled with girder and deck components, and delivered to site ready for installation.

Manufactured from structural grade plywood, Boral's Modular Bridge System can be installed on suitable abutments in as little as just one day (excluding trafficable surface application), significantly reducing road closures, labour expenses and the exposure of personnel to traffic dangers during bridge construction.

BridgeWood Modular Bridges offer flexibility in

engineering and design with a range of thickness, length and width options, all treated to Hazard Level H4 with CoreTreat for fungal decay and termite attack. CoreTreat H4 has a 50 year warranty against decay.

## Features and benefits

- Reduced installation time, road closures and labour costs, making new timber bridges a possibility in most applications
- Installation uses standard equipment and skills
- Can be used with a variety of support structures
- Available as single span or multi-span bridge modules
- Is treated for termites and fungus attack with CoreTreat (H4)
- 50 year warranty on treatment (H4) and glue line
- Has a service life expectancy of over 50 years (H4) with CoreTreat
- Can be used above marine (salt) environments (316 SS fittings required)
- BridgeWood Girders have low tare weight on comparable cross-section with other materials (density 680kg/m<sup>3</sup>)
- Girders suitable for rail direct fix applications, eliminating transoms



BridgeWood installation



Road surface work on BridgeWood





# EzyShield Suburban

**EzyShield Suburban is an engineered plywood wall system designed to provide an effective noise barrier and visual screening for residential and suburban applications.**

EzyShield Suburban is an extension of the popular and proven EzyShield Commercial sound barriers that are commonly viewed on the side of many motorways and railway lines in Australia and New Zealand. State infrastructure bodies such as VicRoads, Queensland Transport, Queensland Rail, Transit NZ and RTA-NSW have extensively used EzyShield Commercial sound barrier systems for over 20 years. The success and technical performance of the EzyShield Commercial sound barrier system has allowed this tried, tested and proven system to be extended into the urban subdivision and dwelling market. The product is typically 21mm, 24mm or 27mm thick and is easy to install with standard tools.

Boral Plywood recommends CoreTreat H3 or H4 for peace of mind and warranty against decay of the sheets.

An EzyShield Suburban fence has the ability to add value to a home by significantly reducing the amount of noise pollution entering a living space. As a general suggestion for optimum sound pollution reduction Boral Plywood suggests building an EzyShield Suburban fence as high as practical. The higher and thicker the EzyShield Suburban fence, the bigger the reduction in noise pollution entering a home.

EzyShield Suburban performs to Australian Standard AS/NZS 2269-2008.

EzyShield Suburban engineered timber panels are manufactured to stress grade F14 with an 'A' type Phenolic marine grade bond using 100% Australian plantation timber. The profile has an attractive rippled face, designed to reduce the effects of weathering over time, and a tongue and groove joining system for a strong, warp resistant structure.

It is recommended that EzyShield Suburban be painted for a longer service life. This also enables a broad scope of aesthetic designs, including murals.

The structural integrity and cross dimensional stability of plywood allows EzyShield Suburban to be used in conjunction with other materials including concrete posts, glass panels and solid timber battens.

The EzyShield Suburban sound barrier system was specifically designed to deal effectively with noise attenuation and privacy screening between housing estates. The Building Code of Australia (BCA) allows fences up to 2m in height to be erected without a permit. Over this height local authority consent may be needed. To provide economical yet strong sheets EzyShield Suburban is available in 21mm, 24mm and 27mm thicknesses, treated with CoreTreat to H3 and H4 Hazard Levels.

## Paint or stain finishing

The application of a paint or stain is strongly recommended to increase the service life of the fence. Boral Plywood recommends only pastel colours be applied to EzyShield Suburban. Boral Plywood recommends a three coat acyclic system be used for any paint application. If the fence is to be stained rather than painted, Boral Plywood recommends using or specifying a film-forming stain with UV filters.

While the effect of weathering over years of exposure will not effect the structural integrity of the EzyShield Suburban panels, the constant movement of the wood fibre will cause surface "checks" (cracks and splits) unless the surface is sealed. Sealing the surface will protect the wood fibre from this constant movement due to moisture and sunlight, and maintain the aesthetics of the natural timber. Consult a paint manufacturer for assistance in the selection of the appropriate paint or stain.



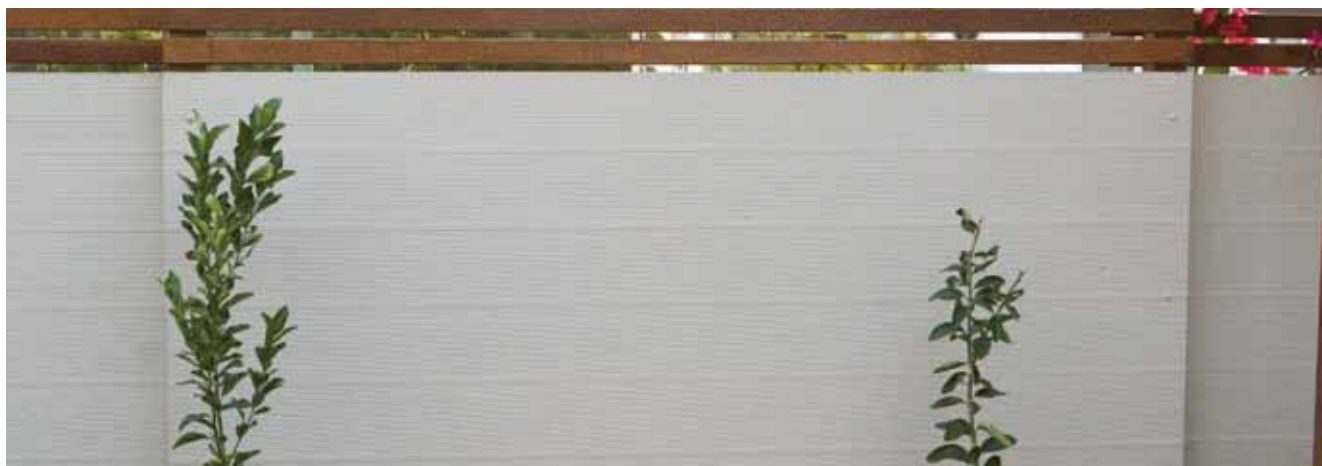

EzyShield Suburban is ideal for housing estates and industrial precincts

### Design

- EzyShield Suburban enables the freedom to create many aesthetically pleasing designs
- Overlap, Staggered or Flat design for fixing to posts can be achieved (see Figure 3.0 below)
- Boral Timber hardwood F14 100 x 100 H4 posts are recommended for total timber installations

### Features and benefits

- Lightweight and easy to install with tongue and groove joining system
- Engineered, warp resistant plywood panels (F14) can be painted for longer service life
- Very high acoustic performance
- Available in CoreTreat treatment against termites and fungus to H3 or H4 Hazard Level
- Supplied with a 40 year warranty against glue failure
- Offers a broad design scope and can be used in conjunction with other building materials
- Offers up to STC 24 for 24mm and STC 28 for 33mm thickness (NAL Report AFT480 and AFT481 respectively)
- Up to a 30dB noise attenuation can be achieved (wall height dependent)



EzyShield Suburban

Figure 3.0

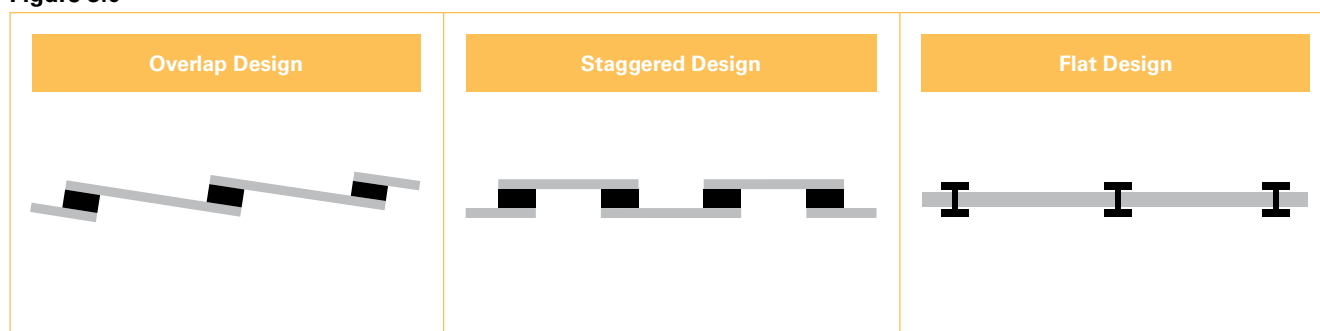

# Evolution Cladding

Evolution exterior plywood cladding provides a striking external appearance for residential and commercial buildings. Evolution Cladding is available in primed or unprimed sheets.

Evolution Cladding is protected against fungal decay and insects with CoreTreat to H3 Hazard Level for outdoor above ground use. CoreTreat is unique to Boral Plywood and is the only way to ensure any unsealed cuts to panels will not decay. This is due to all veneers and complete core being fully H3 treated.

The treated veneers in the sheets are bonded with a permanent phenolic resin, often referred to as a 'Structural Bond' or Marine 'A' Bond and is the same resin used to manufacture marine plywood. The bond will not breakdown under hot, cold or wet conditions. Part of Boral Plywood's rigorous testing requires testing the bonds in boiling water for 72 hours or under high pressure steam for 6 hours to ensure that a solid bond has been made.

Evolution Cladding is suitable for curved applications. An important consideration with a curved wall is the degree of force and the associated fixings required to pull and hold the panel in a radius. Evolution Cladding may be curved along or across the face.

Evolution Cladding can be installed horizontally, however shiplaps must be trimmed and Z-flashings must be used on the horizontal sheet connections. Furthermore, a suitable H-flashing must also be used on the vertical sheet connections.

Evolution Cladding has excellent thermal properties and when combined with insulation batts and reflective sisalation (building paper), compares favourably with heavy weight solid construction for thermal performance.

Figure 4.0

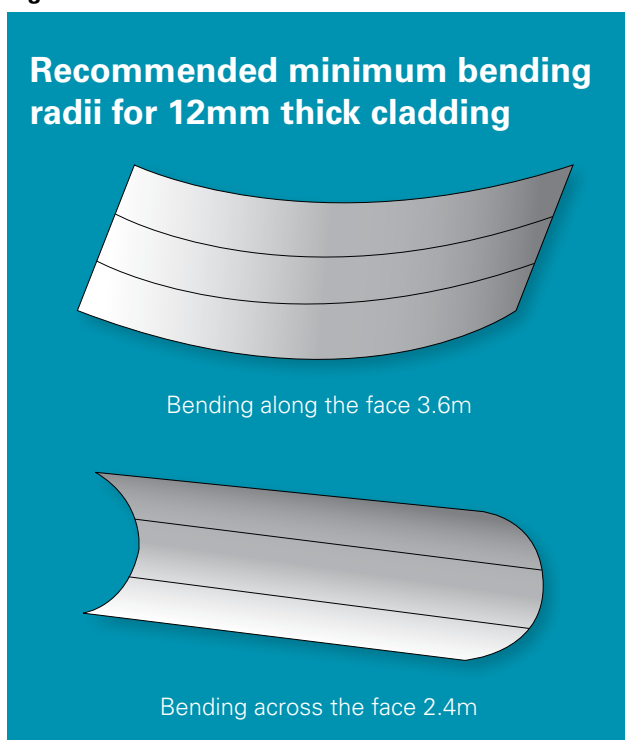
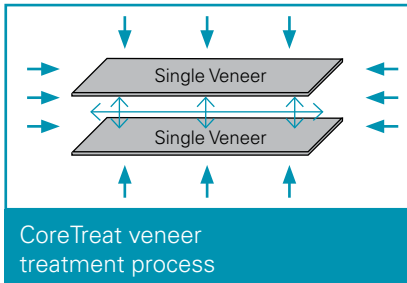

Figure 5.0



## Features and benefits

- Lightweight and easy to install
- Treated with CoreTreat to H3 Hazard Level
- Offers diverse design scope for lightweight structures including curved walls
- Provides a long-lasting and durable external surface
- Has excellent thermal qualities
- Manufactured in Australia for Australian conditions and is backed by Boral
- Does not require battens (these are optional)
- Designed for fixing to both timber and steel framework
- Suitable as a bracing when nailed correctly, negating the need for separate bracing (must be painted if used as bracing)
- Available primed or unprimed
- Manufactured in three profile designs
- Designed with interlocking shiplap system for an easy and sound installation

*Evolution Cladding is treated to the core with CoreTreat*

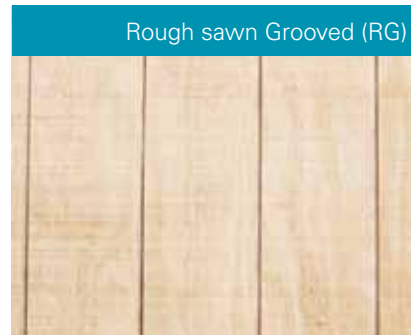
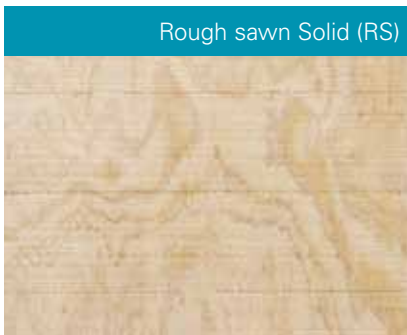

Table 6.0

	Rough Sawn		
	Solid	Grooved	V-Groove
Channel dimensions	No Channel	12mm wide 6mm deep 150mm centres	3mm V-groove 100mm centres
Edge profile	Shiplap		
Surface finish	Band sawn		
Sheet length (mm)	2440 / 2745 / 3050 (3050mm is scarf jointed)		
Sheet width / cover	1216 / 1200		
Sheet thickness	12mm		
Face / Back grade	SD		
Veneer species	Plantation pine		
Approximate weight	2440mm - 23kg / 2745mm - 26kg / 3050mm - 29kg		
Preservative treatment	CoreTreat H3 level by Individual Veneer		
Primed option	Priming available (eliminates need for undercoat)		
Bond type	'A' Marine bond (Phenol formaldehyde)		
EWPAA Certificate	Yes		
Durability	40 years - bond and treatment warranty		
Manufacturing standard	AS/NZS 2269-2008		



## Installation recommendations

- Evolution cladding may be fixed to either timber or steel framed structures. Aluminium framing is not suitable.
- The minimum requirement for timber framing is 70 x 35mm. The minimum requirement for steel framing is 75 x 38mm.
- Evolution Cladding is commonly installed on a stud spacing of 600mm.
- Timber framing should have a moisture content (MC) range of 12-16%.
- Use sisalation (building paper) when installing Evolution Cladding. This is essential when installing sheets horizontally or in steel frame applications and is highly recommended in all other applications.
- Sisalation must be of the highly vapour permeable variety. Please refer to local building codes for further instructions.
- All cladding surfaces must be at least 150mm above ground level. Be sure that garden beds and mulch do not encroach on this clearance over time.
- Allow a 2mm expansion gap between panels to allow for movement due to moisture changes.
- Do not nail top lap.
- Do not put caulking in the weather groove.
- Battens are optional as they are not a structural requirement. The Evolution Cladding profile is shiplapped for a tight fit and adequate moisture protection. Some architects and building designers add timber battens for aesthetic purposes.
- Galvanised steel, UV rated PVC or rubber flashings are suitable. Aluminium flashings are not suitable for use with CoreTreat treated cladding.
- Evolution Cladding may be used as a bracing with resistance of up to 6.4kN/m, provided that the correct nailing pattern is used. See the EWPAA Structural Plywood Wall Bracing - Limit State Design Manual for further instructions. Visit [www.ewp.asn.au](http://www.ewp.asn.au) to download this manual.
- Evolution Cladding should be installed using mechanical Z-flashings with at least a 20mm beak and a 30mm back-stand. Powder coated flashings are acceptable if not scratched in any way prior to installation.

*Evolution Cladding is manufactured from natural, sustainable plantation timber.*

**Table 7.0 - Recommended fasteners**

Frame Type (Domestic)	Fastener size	Type
Nails into timber	40 x 2.8mm	Hot dipped galvanised (HDG) flat head
Screws into timber	#8 x 40mm	Counter sunk HDG self drilling
Screws into steel	10 - 16 - 45	Counter sunk HDG self drilling
Areas exposed to sea air require Stainless Steel type 316 fasteners		

Note: Fasteners must be non-staining and corrosion protected. Aluminium is not to be used unless fully coated by powder coating with no scratches.

## Applications

- Residential: Domestic housing, apartments, beach houses, garden sheds, carports, gazebos, children's playhouses or cubbies, pool shelters
- Commercial: Office building exteriors, hallways, waiting areas, car parks, staff rooms and rest areas
- Industrial: High noise area walls, industrial shed walls, building entrances, foyers, high impact wall linings, structural wall bracing and premium reusable hoarding

**Figure 6.0**

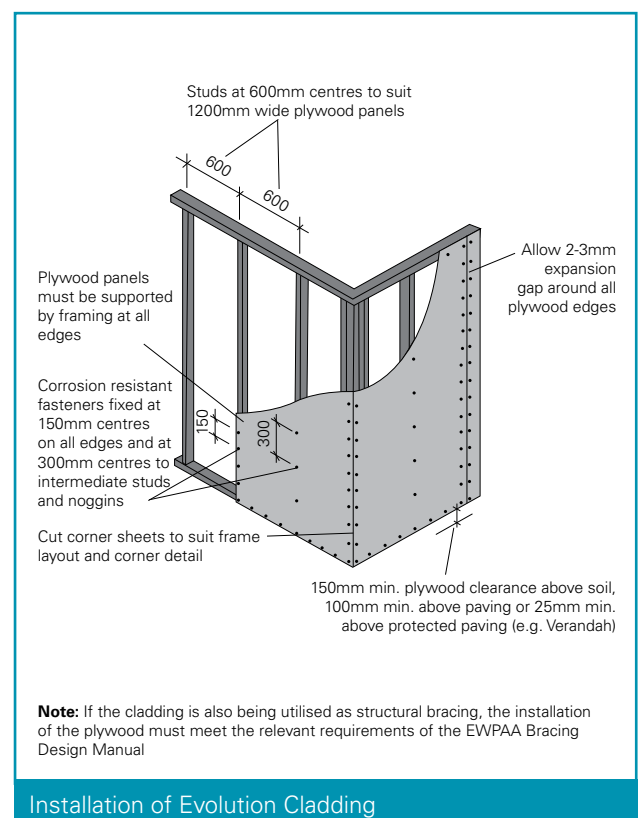

## Finishing recommendations

Evolution Cladding is manufactured from natural plantation timber so it will perform like timber in the open environment. To improve the aesthetic quality of the surface, Evolution Cladding should be protected with an appropriate paint or stain.

- Self-priming acrylic paint systems offer excellent product longevity when applied according to the manufacturer's instructions. They do however cover up the natural beauty of the timber while filling the grain.
- Penetrating oil stains are water based and usually require an initial flooding to allow the stain to penetrate the wood fibre. Recoats can usually be done without sanding. While penetrating oil stains may fade over time, they do not crack or peel. Solvent based stains are not recommended for use with Evolution Cladding.
- Semi-transparent stains allow for flexibility as the timber expands and contracts and will not crack and peel under these conditions. These stains allow the natural characteristics of the timber to be visible.
- Film forming stains are recommended as the best type of stain on the market for coating Evolution Cladding.

Consider the following additional recommendations when finishing and maintaining Evolution Cladding.

- Test sample paints and stains before deciding on a colour.
- Avoid painting on very hot or cold days. Between 10°C and 30°C is an ideal temperature range.
- Consider the Evolution rough sawn profile for higher protection from UV rays. While it requires more paint, the roughness diffuses UV rays.

*Evolution Cladding has excellent thermal properties and when combined with insulation batts and reflective sisalation, compares favourably with heavy weight solid construction for thermal performance.*

- Seal all edges and shiplap joints to reduce the risk of moisture uptake, which can distort the panel.
- Avoid colours that are too dark as this will accelerate surface checking. Any colour that is not a pastel is considered to be a dark colour.
- In areas of high humidity, a mould retardant should be added to prevent mould growth.
- Ensure that all surfaces are clean and dry before applying paint.
- Repaint only as required. South facing walls will require less maintenance than west facing surfaces.



Boral Evolution external cladding

# Plywood Cladding Installation Details

**7.0 Typical Stud Fixing (Vertical Fixing)**

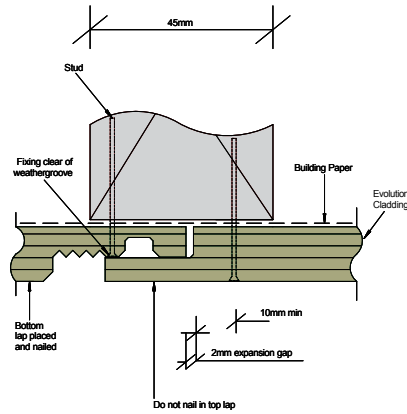

**7.1 Overhangs and Ground Clearances**

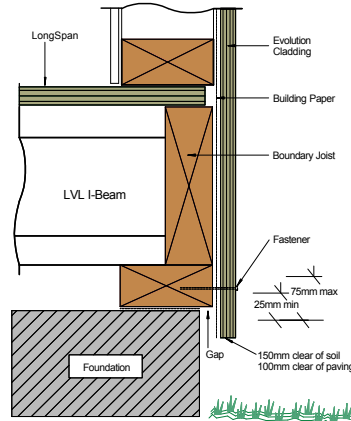

**7.2 Wall Sections (2745mm Sheet)**

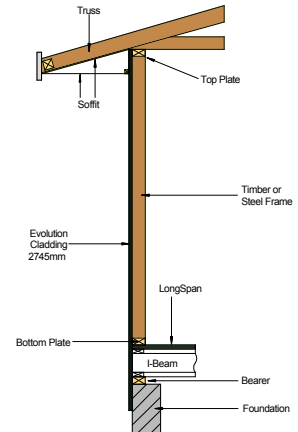

**7.3 External Corners**

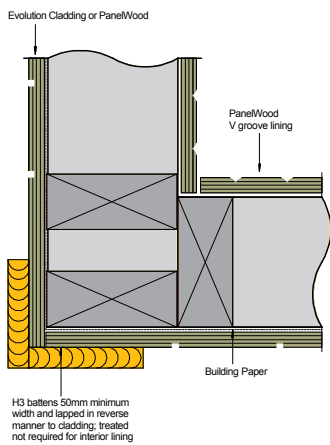

**7.4 Horizontal Joins**

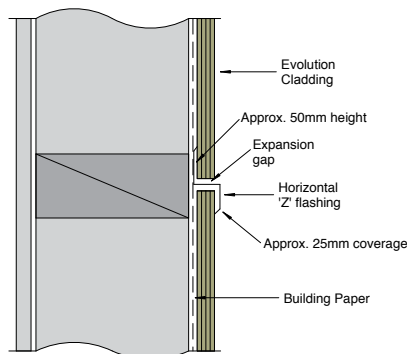

**7.5 Mid Floor Level (2)**

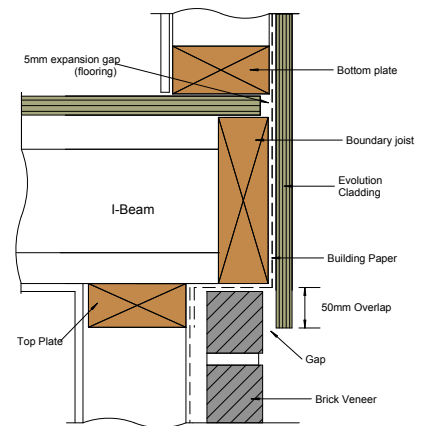

**7.6 Internal Corner Board**

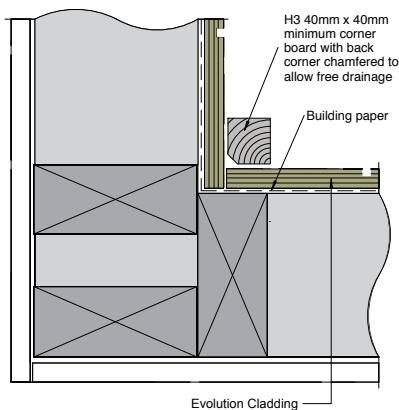

**7.7 Protection from Moisture and Soil**

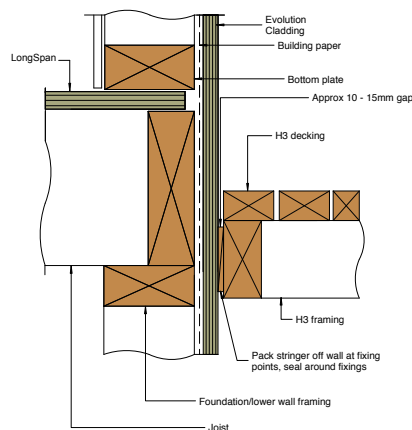

**7.8 Mid Floor Level (1)**

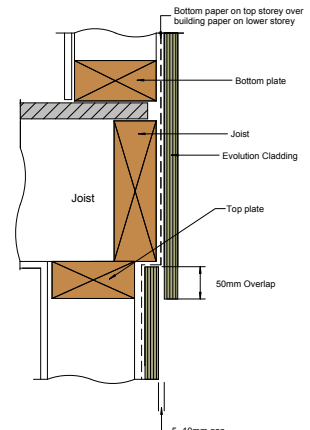



# Pioneer Cladding

Pioneer Cladding is an LOSP envelope treated panel for use as exterior cladding on residential and commercial buildings.

Pioneer Cladding is designed to be a value-oriented alternative plywood cladding for the house cladding market. It is envelope treated with a preservative that has been used for over 20 years in the Australasian market. This preservative, commonly known as Light Organic Solvent Preservative (LOSP), provides a 15 year decay resistance warranty. By comparison, Evolution Cladding with CoreTreat gives a 40 year warranty in a Hazard Level 3 (H3) environment and is treated to the core.

Pioneer Cladding panels should be allowed a 14 day resting period in which the solvents used in treatment are given time to evaporate prior to painting. Evolution Cladding with CoreTreat may be painted immediately.

Note: Pioneer Cladding is not warranted by Boral Plywood when installed horizontally. If a horizontal application is necessary Boral Plywood Evolution Cladding must be used.

## Features and benefits

- Lightweight and easy to install
- Treated with LOSP to H3 Hazard Level giving a 15 year above ground, decay resistance warranty
- Offers diverse design scope for lightweight structures, including curved walls
- Provides a long-lasting and durable external surface
- Has excellent thermal qualities
- Manufactured in Australia for Australian conditions and backed by Boral
- Does not require battens (these are optional)
- Designed for fixing to both timber and steel framework
- Suitable as a bracing when nailed correctly (negating the need for bracing if painted)
- Manufactured in three profile designs
- Designed with interlocking shiplap system for an easy installation



Boral Pioneer Cladding

Rough sawn V-grooved (RV)



Rough sawn Solid (RS)



Rough sawn Grooved (RG)



# Frequently asked questions

## Q. How long can plywood be left exposed to the weather during construction?

**A.** Untreated plywood will maintain its integrity for up to three months under normal construction conditions. It is important to minimise pooling of water on plywood during construction. Some yellowing and surface checking cracks may occur if left unprotected.

## Q. Can untreated plywood be painted or sealed and still used outside?

**A.** Preservative treatment of plywood is the only means of guaranteeing long-term durability in exposed external applications or where the moisture content will regularly exceed 18%. However, if it can be guaranteed that the plywood will remain dry, for instance by encapsulating it in fibreglass, then an untreated product will suffice. It should be noted that most paint systems are 20% to 30% porous in exposed weather conditions.

## Q. What preservative treatments are available for Boral Plywood products?

**A.** Boral Plywood provides protection for applications that are both above ground and in-ground contact. The following treatments are available.

**Table 8.0**

Bifenthrin H2	Clear in colour, an additive to the glue formulation in the pressing of the panel. Odourless and colourless. Recommended for appearance, can be used below the Tropic of Capricorn (as per QLD treatment regulations).
CCA H3	Green in colour, based on a Copper-Chrome-Arsenic formulation. Recommended for non-appearance applications and industrial solutions above ground or in-ground contact.
LOSP H3	Clear in colour, based on Light Organic Solvent Preservative formulation. Recommended for appearance applications above ground contact.
CoreTreat H3	Light green to brown in colour. Recommended for appearance applications above ground contact. Due to the product being treated before the veneer is pressed into a panel, the entire core is treated so cutting the panel will not break the treatment envelope, unlike all other treatments. CoreTreat is considered the best decay protection for plywood that can be achieved.
CoreTreat H4	Light green to brown in colour. Recommended for appearance applications above ground contact, but harsher environments than H3. The best plywood treatment available.
CCA H4	Green in colour, based on a Copper-Chrome-Arsenic formulation. Recommended for non-appearance applications and industrial solutions with in-ground contact.

## Q. Can plywood be used in a structural diaphragm?

**A.** Boral Plywood provides an effective diaphragm solution when designed and constructed in accordance with appropriate engineering specifications.

## Q. How can I identify the grade of plywood on a sheet?

**A.** To identify the grade of Boral Plywood, refer to details on the sheet label.

## Q. What sealants can be painted over and used with treated plywood?

**A.** Co-polymer sealants can be painted over and are compatible with treated plywood, both CCA, CoreTreat and LOSP. Silicone sealants are not recommended in these applications.

## Q. Do cut edges of treated plywood need to be re-treated in an outdoor application?

**A.** Not if you are working with CoreTreat product. If you are working with CCA or LOSP it is important to re-seal any cuts or machining profiles with brush-on remedial treatments.

## Q. What types of glues are used in the manufacture of plywood?

**A.** The Boral Plywood product range uses A-bond phenol formaldehyde "Phenolic" resin that is designed for structural applications. It is a thermosetting glue that will not deteriorate under the stress of heat, cold or water. It is dark red/brown in colour. It emits no formaldehyde once set, achieving the E<sub>0</sub> emission standard.

## Q. What expansion should be allowed for in plywood that may be wet during construction?

**A.** The cross-ply construction of plywood, with successive layers of veneer glued at right-angles to each other, provides a very stable structural product even when wet. Typically, a 2400mm x 1200mm sheet of plywood will swell between 1.3mm and 2.3mm both across and along the sheet when wet. When using tongue and groove flooring, it is recommended that a 5mm expansion gap be allowed for around the perimeter of the floor.

## Q. How should plywood be used to maximise its stiffness properties?

**A.** Structural plywood has greatest stiffness along the long-grain of the sheet, i.e. along its length, not across the width. Accordingly, flooring and roofing must be laid with the length running across the joists. If cutting plywood for shelving, the long-grain should be used between shelf supports.

### Q. What standards govern plywood production?

**A.** The highest quality for plywood production is the Engineered Wood Products Association of Australasia (EWPPAA) Process Quality Control Program which assures the quality of Boral Plywood with an independent quality assurance system. The EWPPAA quality stamp ensures all relevant Australasian standards for plywood production have been met. Boral Plywood products are certified by EWPPAA as being E<sub>0</sub> - in the lowest formaldehyde emission class available.

### Q. What grades of veneer are available on plywood faces?

**A. A grade** - Clear wood grain and limited natural features such as AC PremierWood and AA Marine

**B grade** - Attractive wood character, minor features blended with uniform wood grain such as Evolution Cladding and PanelWood

**C grade** - Displays the true nature of wood with sound natural features and distinctive wood grain such as StructuralWood CD and EverWood.

**D grade** - Non-appearance face but with full structural integrity such as BraceWood and UnderPly.

### Q. What plywood do I use for the following applications?

**A. Tree hut or cubby house** - EverWood or Evolution Cladding (depending on the desired finish effect)

**Drawer bottoms** - OzWood; 4mm or 6mm

**Letterbox** - Depending on aesthetic considerations, CoreTreat BC or Evolution Cladding

**Decking on trailers** - EverWood to provide a smooth finish.

### Q. Does plywood emit formaldehyde vapour?

**A.** Boral Plywood has the lowest formaldehyde emissions of any wood-based panel product and well below the international E<sub>1</sub> standard for housing applications. All Boral Plywood is certified to E<sub>0</sub> standard, the lowest vapour rating possible.

### Q. Should nails or screws be used to fasten plywood to posts?

**A.** Boral recommends that screws (self-drilling or countersunk) be used in this application. Flat-head nails can be used but may be subject to "pulling" should the posts swell and contract.

### Q. What is marine plywood?

**A.** Marine plywood is the same as structural plywood except that the veneer grades are much higher, eliminating all core gaps and defects. The glue line is exactly the same in marine ply as in structural plywood. Marine plywood is very rarely treated as it is usually given a resin, fibreglass or paint finish. However, structural plywood has greater durability when CoreTreat is used.

### Q. What filler should be used to plug nail holes in plywood?

**A.** Common wood fillers can be used with plywood, but it is important to consider the durability requirements of the application. For example, an epoxy filler must be compatible with the coating system to be applied over the plywood.

### Q. How close to the sheet edge can plywood be nailed?

**A.** All fastenings should be fixed no closer than 10mm from sheet edges.

### Q. Is Boral Plywood guaranteed for 40-years in construction applications?

**A.** Boral Plywood is guaranteed to meet the structural performance and durability requirements of the Australian Building Code, furthermore it will not delaminate for 40 years or more if installed and maintained correctly.

### Q. What grade of plywood is recommended for temporary site hoarding?

**A.** The minimum structural grade suitable for temporary fencing is DD. If the fencing is expected to be used for more than three months, DD grade treated to H3 should be used. When the ply face is exposed to the public or footpath use CD grade.

### Q. What is the weight of plywood?

**A.** The approximate density of Boral Plywood is 620 kg/m<sup>3</sup> for all types and sizes. This can vary however, dependent on species or conditions.



# customised product solutions

Over the last 50 years, Boral Plywood has developed unique customer and project specified products that are not available from other manufacturers.

Boral Plywood offers the combination of technical know-how, machine capability and scale to meet demanding, non-standard requests from constructors and customers looking for purpose designed plywood for a specific project. Boral Plywood can develop plywood sheeting for broad applications such as bridges and transport flooring as well as abrasion resistant surfaces for the materials handling industry.

Value added features available include scarf-jointing, fire-retarding, cut to size, treatment to resist termites (H2), treatment to resist decay (H3 and H4) and custom slotting for sound attenuation applications.

If a plywood product needs to be custom manufactured to perform a special purpose, Boral Plywood can build the right plywood sheet.



## References

1. NAFI, Forest industries and climate change, March 2007
2. Bureau of Rural Sciences: Australia's State of the Forest Report 2008

Limitations: All products and relative statements within this document are subject to the applicable panels being installed, removed, stored, and handled in accordance with information mentioned, and subject to the governing codes of practice. Boral Plywood retains the right to change specifications without notice in accordance with its policy of continued product development. Every care has been taken in preparing the information contained within this publication, however, the company cannot accept responsibility for any inaccuracies that may have arisen, and cannot accept liability for loss or damage either direct or consequential arising out of or in relation to use or application of the said information. Certain species are supplied on the basis of availability.

[www.boralplywood.com.au](http://www.boralplywood.com.au)  
Free call 1800 773 596  
[plywood@boral.com.au](mailto:plywood@boral.com.au)

# Boral Plywood

