



# LSSA<sup>®</sup>

Louvre & Shutter Systems Australia

## **LSSA ALUMINIUM ELIPTICAL MOVEABLE AND FIXED LOUVRES**

LSSA has a innovative new concept in the manufacture of louvre systems.



Our Louvre system is architecturally designed with emphasis on durability, security and structural integrity. The trend is now towards Alfresco entertainment areas and our shutters enhance any area, are aesthetically pleasing and provide shade, ventilation, and privacy when needed. Designed for both interior and exterior use, our shutters are elegant in appearance. The internal drive mechanism is housed within the frame to provide unobstructed views.

We provide quality hardware to incorporate ease of operation and functionality. The operation of Bi-folding, Sliding or Stacking allow you to make the most of all areas of your property.

**Manufactured of aluminium, we do provide a limited warranty on our product.**  
*Manufactured in Australia by Australians.*

Call 02 4294 9722

or visit [www.lssa.com.au](http://www.lssa.com.au)

## Points of value

- Aesthetically pleasing and visually stunning
- Corrosive resistant linkage system hidden inside the styles
- Can be manufactured in bays for privacy, top section open/bottom section can be closed
- Sliding, Hinged or Fixed
- Manual and Motorized Operation
- Powder Coat or anodised colour selection
- Our louvres can be installed inside or outside
- Commercial and Residential Applications
- Privacy when closed, semi private when open
- Control of Light and Heat
- Energy Efficient
- Control Ventillation
- Extra Security
- Extruded Aluminium Powdercoat on Anodised
- Requires little maintenance & long lasting
- Easy to Clean & Tough wearing
- Suits commercial and residential applications
- Weather proof
- No dirty cords
- Aluminium - The Way of the Future



## Specifications - Blade size: 80mm x 12.59mm

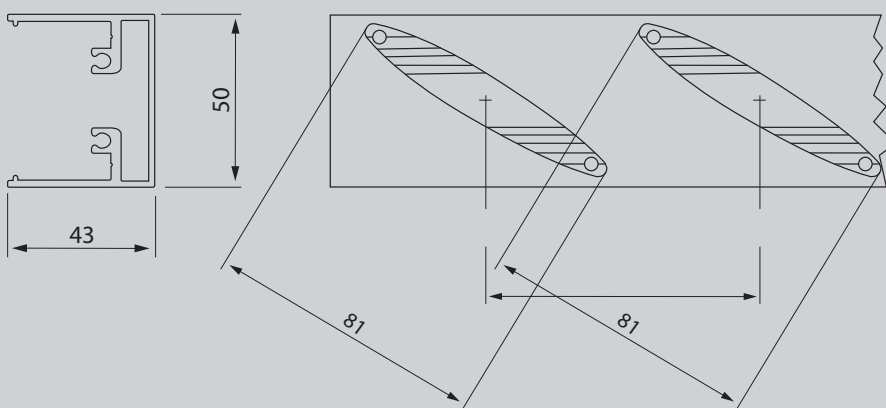

Contact us to find out how Louvre and Shutter Systems Australia can help you control your light and shade today!

If you have any queries, please contact **LSSA** on **02 4294 9722**