

External cladding

Installation guide

EasyLap™ panel



James Hardie
A smarter way to build

AUSTRALIA
JULY 2009

CONTENTS

1	INTRODUCTION	2
2	SAFE WORKING PRACTICES	4
	Warning	4
	Recommended safe working practices	4
	Storage and handling	4
3	DESIGN / FRAMING	4
	Scope	4
	Design	4
	Framing	5
4	PREPARATION AND FASTENERS	6
	Preparation	6
	Fasteners	6
	Sheet Installation	6
5	DETAILS	8
	Window Details	8
	External Corner Details	8
	Internal Corner Details	8
	Junction Details	9
6	FINISHES AND MAINTENANCE	10
	Finishes	10
	Maintenance	10
7	PRODUCT INFORMATION	11
8	WARRANTY	11

WE VALUE YOUR FEEDBACK

To continuously improve the development of our products and systems, we value your input. Please send any suggestions, including your name, contact details, and relevant sketches to:

Ask James Hardie™

Fax 02 9638 9535

literaturefeedback@jameshardie.com.au

1 INTRODUCTION

The James Hardie EasyLap™ panel is a strong fibre cement base sheet with a shiplap vertical joint, that is finished with a site applied roll on textured acrylic paint to create a rendered look with a subtle vertical joint.

The EasyLap™ panel is used as an external wall cladding in alterations and additions and residential single and medium density dwellings where a uniform, broadwall cladding is required. Ideal for full wrap or composite construction design on either timber or steel framed homes.

If you are a specifier...

or other responsible party for a project, ensure the information in these specifications is appropriate for the application you are planning and that you undertake specific design and detailing for areas which fall outside the scope of these specifications.

If you are an installer...

Ensure that you follow the design, moisture management and associated details and material selection provided by the designer and the EasyLap™ panel Installation Manual.

Make sure your information is up to date

When specifying or installing James Hardie products, ensure you have the current manual. Additional installation information, warranties and warnings are available at www.jameshardie.com.au or Ask James Hardie™ on 13 11 03.

IMPORTANT NOTES

1. Failure to install, finish or maintain this product in accordance with applicable building codes, regulations, standards and James Hardie's written application instructions may lead to personal injury, affect system performance, violate local building codes, and void James Hardie's product warranty.
2. All warranties, conditions, liabilities (direct, indirect or consequential) and obligations whether arising in contract, tort or otherwise other than those specified in James Hardie's product warranty are excluded to the fullest extent allowed by law. For James Hardie's product warranty information and disclaimers about the information in this manual, see the section at the end of this manual.
3. The builder must ensure the product meets aesthetic requirements before installation. James Hardie will not be responsible for rectifying aesthetic surface variations following installation.
4. Make sure your information is up to date. When specifying or installing James Hardie® products, ensure you have the current manual. If in doubt, or you need more information, visit www.jameshardie.com.au or Ask James Hardie™ on 13 11 03.





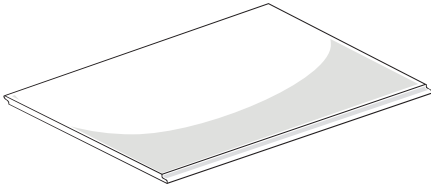

EASYLAP™ PANEL SIZES (MM)

Pre-primed sheet with a ship lap edge joint along the two long edges. Sheet weighs approximately 12kg/m² in equilibrium.

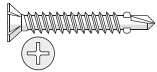
	LENGTH	WIDTH	THICKNESS	MASS (kg)
	2440	1200	8.5	36
	3000	1200	8.5	44
	3000	900	8.5	33
	PART NO.	PRODUCT SIZES (mm)		
	404186	3000 x 900		
	404184	2440 x 1200		
404185	3000 x 1200			







All dimensions and masses are approximate and subject to manufacturing tolerances.

ACCESSORIES / TOOLS SUPPLIED BY JAMES HARDIE

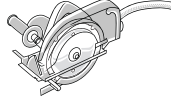
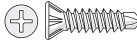
ACCESSORIES	DESCRIPTION	QUANTITY
	HardiDrive® screw 32mm long Class 3 galvanised screw for fixing into 0.80 - 1.6mm BMT steel framing Part No. 300637	Pack of 1000
	50mm foam back sealing tape Self-adhesive EPDM foam tape applied under sheet joins to the vapour permeable membrane along the stud face. The tape helps to improve water tightness. Part No. 304560	Roll 50mm wide x 1.6mm thick x 25 metres long
	James Hardie joint sealant Paintable polyurethane sealant. Suitable as a general purpose paintable exterior grade sealant. Part No. 300753	Pack of 20 300mL cartridge
	EasyLap Aluminium Internal Corner Anodised aluminium extrusion used to create internal corners. Part No. 305262	3.0m Length
	EasyLap Aluminium External Corner Anodised Aluminium Extrusion to create external corner. Part No. 305261	3.0m length
	James Hardie Corner Flashing 75 x 75 x 0.48mm Colorbond®. For use behind cladding at internal and external corners. 3.0m lengths. Part No. 304891	3.0m lengths
TOOLS		
	HardiBlade® saw blade Diamond tip 185mm diameter circular saw blade, for fast, clean cutting of EasyLap panels. Part No. 300660	Each

ACCESSORIES / TOOLS NOT SUPPLIED BY JAMES HARDIE

James Hardie recommends the following products for use in conjunction with the EasyLap panels. James Hardie does not supply these products. Please contact the component manufacturer for information on their warranties and further information on their products.

ACCESSORIES	DESCRIPTION		QUANTITY
	Vapour permeable membrane Must have the following properties in accordance with AS/NZS 4200.1: Vapour barrier - low or medium Water barrier - high		Dust-reducing saw Dust reducing saw with a HardiBlade® saw blade Makita 5057KB Hitachi C7YA
	Buildex FibreZIPS® 30mm long for fixing EasyLap panels into steel frames of 0.55mm to 0.75mm BMT.		Vacuum extraction with HEPA filter Used with HEPA filter and paper bag for reduced dust exposure
	Fibre cement nails 2.8 x 30mm corrosion resistant fibre cement nail for fixing EasyLap panels onto timber stud frame.		Gun nail A 2.8 x 40mm minimum class 3 nail with a minimum 6mm head diameter.
	Roll on Texture Paint EasyLap panels are designed to have a rolled on texture coat. Refer to Wattyl, Dulux, Taubmans or equivalent product manufacturer, see section 6 for more information.		Epoxy Flush Sealing (2 part) Countersunk head screws are flush filled using Hilti CA125 or Megapoxy P1

2 SAFE WORKING PRACTICES

WARNING - DO NOT BREATHE DUST AND CUT ONLY IN WELL VENTILATED AREA

James Hardie products contain sand, a source of respirable crystalline silica which is considered by some international authorities to be a cause of cancer from some occupational sources. Breathing excessive amounts of respirable silica dust can also cause a disabling and potentially fatal lung disease called silicosis, and has been linked with other diseases. Some studies suggest smoking may increase these risks. During installation or handling: (1) work in outdoor areas with ample ventilation; (2) minimise dust when cutting by using either 'score and snap' knife, fibre cement shears or, where not feasible, use a HardiBlade® saw blade and dust reducing circular saw attached to a HEPA vacuum; (3) warn others in the immediate area to avoid breathing dust; (4) wear a properly-fitted, approved dust mask or respirator (e.g. P1 or P2) in accordance with applicable government regulations and manufacturer instructions to further limit respirable silica exposures. During clean-up, use HEPA vacuums or wet cleanup methods - never dry sweep. For further information, refer to our installation instructions and Material Safety Data Sheets available at www.jameshardie.com.au. FAILURE TO ADHERE TO OUR WARNINGS, MATERIAL SAFETY DATA SHEETS, AND INSTALLATION INSTRUCTIONS MAY LEAD TO SERIOUS PERSONAL INJURY OR DEATH.

JAMES HARDIE RECOMMENDED SAFE WORKING PRACTICES

CUTTING OUTDOORS

- Position cutting station so wind will blow dust away from the user or others in working area.
- Use one of the following methods based on the required cutting rate:
 - Best** ▪ Score and snap ▪ Hand guillotine ▪ Fibreshear
 - Better** ▪ Dust reducing circular saw equipped with HardiBlade® Saw blade and HEPA vacuum extraction.
 - Good** ▪ Dust reducing circular saw equipped with HardiBlade® saw blade.

CUTTING INDOORS

- Cut only using score and snap, hand guillotine or fibreshears (manual, electric or pneumatic).
- Position cutting station in a well-ventilated area

DRILLING / OTHER MACHINING

When drilling or machining you should always wear a P1 or P2 dust mask and warn others in the immediate area.

IMPORTANT NOTES

- For maximum protection (lowest respirable dust production), James Hardie recommends always using "Best" - level cutting methods where feasible.
- NEVER use a power saw indoors.
- NEVER use a circular saw blade that does not carry the HardiBlade logo.
- NEVER dry sweep - Use wet suppression or HEPA vacuum.
- NEVER use grinders.
- ALWAYS follow tool manufacturers' safety recommendations.

P1 or P2 respirators should be used in conjunction with above cutting practices to further reduce dust exposures. Additional exposure information is available at www.jameshardie.com.au to help you determine the most appropriate cutting method for your job requirements. If concern still exists about exposure levels or you do not comply with the above practices, you should always consult a qualified industrial hygienist or contact James Hardie for further information.

STORAGE AND HANDLING

To avoid damage, all James Hardie building products should be stored with edges and corners of the product protected from chipping. James Hardie building products must be installed in a dry state and protected from weather during transport and storage. The product must be laid flat under cover on a smooth level surface clear of the ground to avoid exposure to water, moisture, etc.

3 DESIGN / FRAMING

SCOPE

General

This manual covers the use of the EasyLap™ panel in a residential wall application over a seasoned timber wall frame or a light-gauge steel frame installed in a vertical upright application.

DESIGN

General

All design and construction must comply with the appropriate requirements of the current Building Code of Australia (BCA) and other applicable regulations and standards.

Responsibility

The specifier or other party responsible for the project must ensure that the details in this specification are appropriate for the intended application and that additional detailing is performed for specific design or any areas that fall outside the scope of this specification.

Slab and footings

The slab and footings on which the building is situated must comply with AS 2870 'Residential slabs and footings - Construction' and the requirements of the Building Code of Australia (BCA).

Ground clearances

Install James Hardie external cladding with a minimum 150mm clearance to the earth on the exterior of the building or in accordance with local building codes if greater than 150mm is required. Maintain a minimum 50mm clearance between James Hardie external cladding and roofs, decks, paths, steps and driveways.

Adjacent finished grade must slope away from the building in accordance with local building codes, typically a minimum slope of 50mm minimum over the first metre.

Do not install external cladding such that it may remain in contact with standing water.

NOTE

Greater clearance may be required in order to comply with termite protection provisions, see below for more information.

Termite Protection

The BCA specifies the requirements for termite barriers. Where the exposed slab edge is used as part of the termite barrier system, a minimum of 75mm of the exposed slab edge must be visible to permit ready detection of termite entry.

Structural bracing

EasyLap™ panels can be installed to provide wall bracing against lateral forces due to wind. For further information, Ask James Hardie™ on 13 11 03.

Fire rated walls

EasyLap™ panels can achieve fire ratings of 60/60/60 and 90/90/90 when constructed as specified in the James Hardie Fire and Acoustically Rated Design Manual and Construction of Fire and Acoustically Rated Walls Technical Specification.

Moisture Management

It is the responsibility of designer or specifier to identify moisture related risks associated with any particular building design. Wall construction design must effectively manage moisture, accounting for both the interior and exterior environments of the building, particularly in buildings that have a higher risk of wind driven rain penetration or that are artificially heated or cooled.

In addition all wall openings, penetrations, junctions, connections, window sills, heads and jambs must incorporate appropriate flashing and waterproofing. Materials, components and their installation that are used to manage moisture in framed wall construction must, at a minimum, comply with the requirements of relevant standards and the BCA.

Vapour permeable membrane

A vapour permeable membrane must be installed under EasyLap™ panels in accordance with the AS/NZS 4200.2 'Pliable building membranes and underlays – Installation' and the manufacturer's specifications.

The membrane must have the following properties in accordance with AS/NZS 4200.1:

- Vapour barrier - low or medium
- Water barrier - high

The function of the vapour permeable membrane is to prevent moisture ingress by acting as a "drainage plane" whilst enabling water vapour build up from inside the frame to escape.

Flashing

All wall openings, penetrations, intersections, connections, window sills, heads and jambs must be flashed prior to cladding installation.

FRAMING

General

The EasyLap™ panels are installed vertically to both timber and metal studs.

For Timber framing, the framing width at sheet joints must be a minimum of 45mm and 50mm wide for steel frames. Where the studs at sheet joints are less, provide double 35mm wide studs at sheet joints. Ensure double studs are well fastened together and flush at the outside face.

All intermediate support studs must be a minimum of 70 x 35mm for timber and 64 x 35mm deep for metal framing.

Maximum stud spacings for EasyLap™ panels for wind load classifications of AS 4055 'Wind Loads for Housing' are given in Table 1.

TABLE 1

MAXIMUM STUD & FASTENER SPACING					
AS 4055 Wind Classification		General Areas of Walls (mm)		Within 1200mm of Building Edges (mm)	
Non-Cyclonic	Cyclonic	Stud Spacing	Fastener Spacing	Stud Spacing	Fastener Spacing
N1, N2, N3, N4	C1, C2	600	200	600	200
N5	C3	450	200	300	150
N6	C4	450	150	300	125

Timber

Use of timber framing must be in accordance with AS 1684 - 'Residential timber-framed construction' and the framing manufacturer's specifications.

Use only seasoned timber. Unseasoned timber must not be used because it is prone to shrinkage and can cause sheets and frames to move.

'Timber used for house construction must have the level of durability appropriate for the relevant climate and expected service life and conditions including exposure to insect attacks or to moisture, which could cause decay.' Reference AS 1684.2

'Residential timber-framed construction'.

Steel

Use of steel framing must be in accordance with AS 3623 - 'Domestic metal framing' and the framing manufacturers specifications.

Framing members must have a base metal thickness (BMT) between 0.55 to 1.6mm. The steel framing must have the appropriate level of durability required to prevent corrosion.

Tolerances

Ensure frame is square and work from a central datum line. Frames must be straight and true to provide a flush face to receive the sheeting.

A suggested maximum tolerance of between 3mm and 4mm in any 3000mm length of frame will give best results. EasyLap™ panels will not straighten excessively warped or distorted frames and any warping may still be visible after the cladding is applied.



FIGURE 1 FRAME STRAIGHTNESS

4 PREPARATION AND FASTENERS

PREPARATION

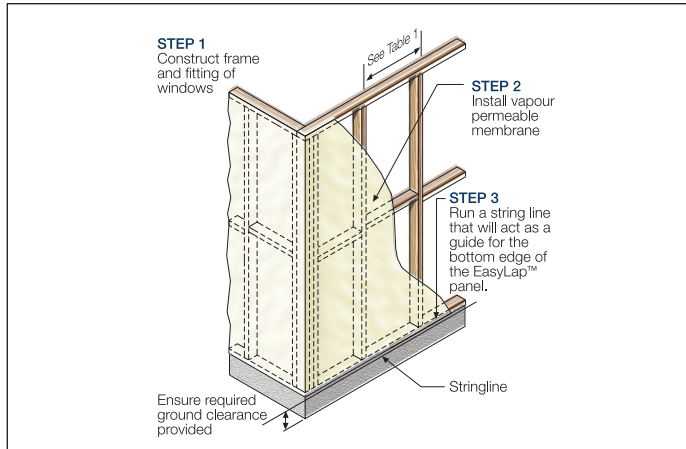

FIGURE 2 PREPARATION

NOTES

Generally, external and internal corners have additional framing requirements. Refer to the external and internal corner details for more information.

FASTENERS

General

All nails must be driven flush. Screws may be driven flush or countersunk 1.5mm and filled over flush with Megapoxy P1 or Hilti CA 125 where the temperature is below 15° use Hilti CA 273.

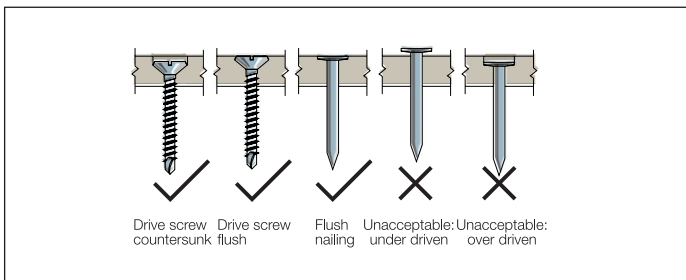

FIGURE 3 NAIL FASTENER DEPTH

Fasteners should be screwed as close as possible to the stud corners to avoid deflection of the stud flange, see Figure 4.

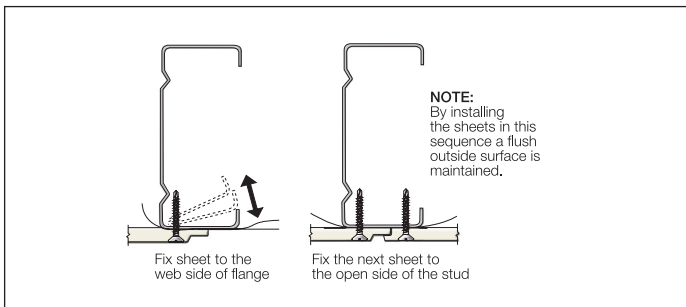

FIGURE 4 SCREW FASTENING

Fastener Durability (Including coastal areas)

Fasteners must have the appropriate level of durability required for the intended project. In areas within 1km of a coastal area, areas subject to salt spray and other corrosive environments, class 4 fasteners must be used. All other areas require a minimum class 3 fastener. Fasteners must be fully compatible with all other materials that they are in contact with to ensure the durability and integrity of the assembly. Contact fastener manufacturers for more information.

Timber frames

For timber frames, use a 2.8 x 30mm galvanised fibre cement nail.

Steel frames

For 0.55mm - 0.75mm BMT steel framing, use 30mm Buildex FibreZIP® screws. For 0.8mm - 1.6mm BMT steel framing, use 32mm HardiDrive® screws or Quickdrive 32mm (CBSOG114-SA).

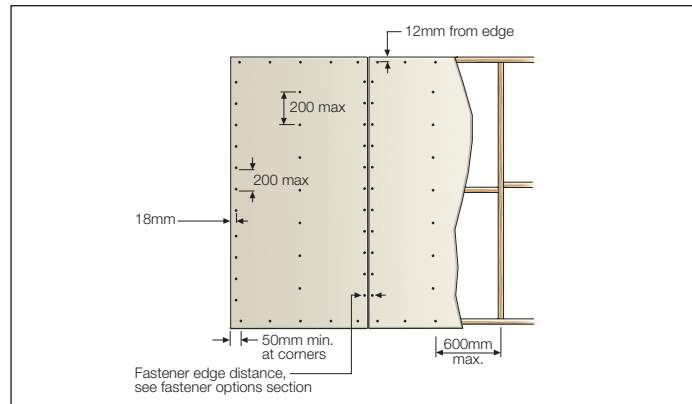

FIGURE 5 SHEET FASTENING SPACING

SHEET INSTALLATION

NOTE

You must ensure the product is of acceptable quality prior to installation, see Important Note 3 on page 2.

EasyLap™ panels must be installed vertically with all sheet edges fully supported. Centre of sheet joints must coincide with the centre line of the framing member and all sheets are installed in one direction.

At every vertical sheet joint, a 50mm foam back sealing tape is applied under the shiplap vertical joint and in front of the vapour permeable membrane, see Figure 6.

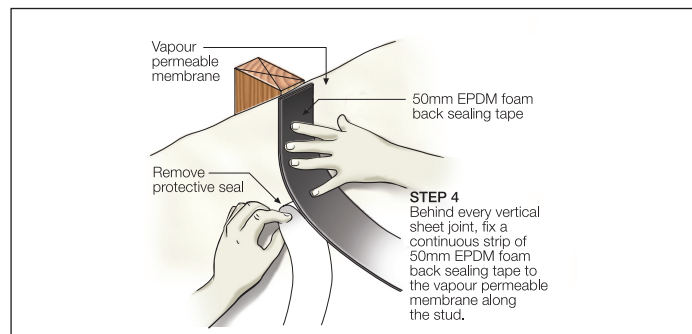

FIGURE 6 APPLY FOAM TAPE AT SHEET JOINTS

To ensure the fasteners fixed at the edge of the sheet has adequate edge distance into the stud, position the underlap sheet on every stud 3mm beyond the centre of the stud.

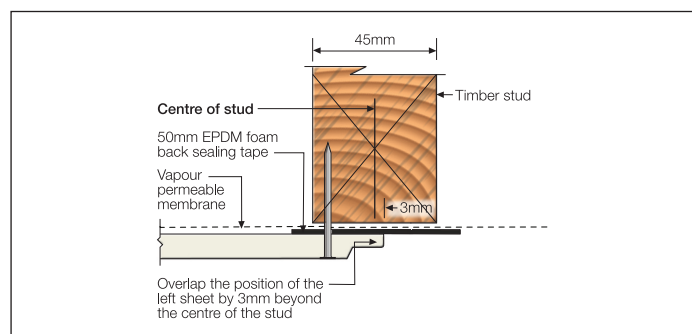

FIGURE 7 SHEET EDGE POSITION ON STUD

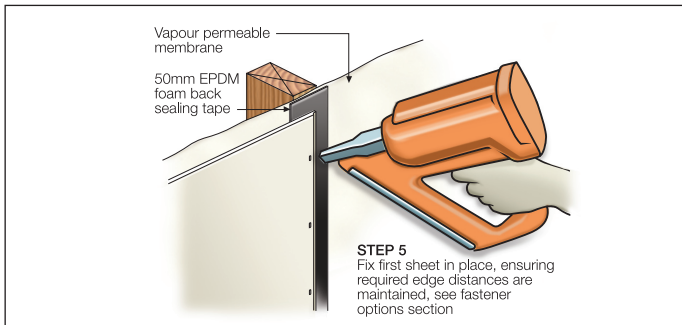

FIGURE 8 FIX FIRST SHEET

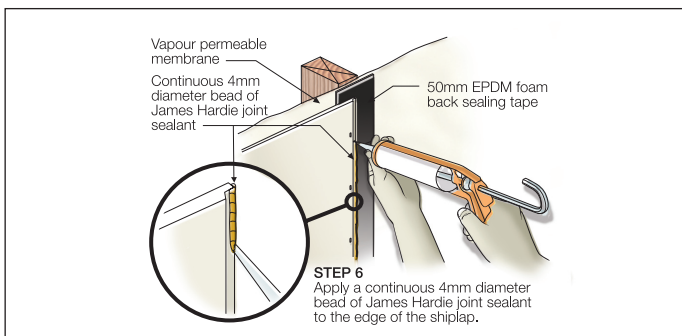

FIGURE 9 APPLY JOINT SEALANT

NOTE

1. Notch tip of sealant nozzle to act as a guide down the sheet edge.
2. Alternatively, it is acceptable to apply sealant to the overlapping sheet edge before installation.

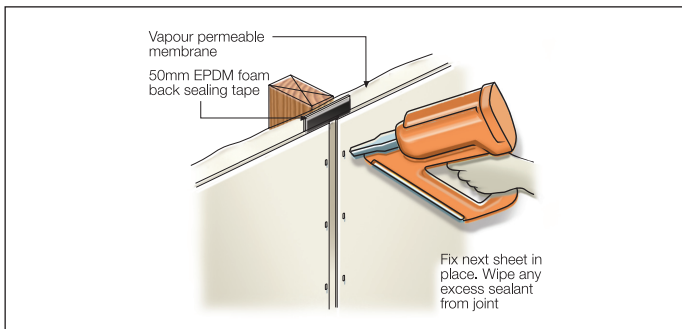

FIGURE 10 FIX NEXT SHEET

NOTE

After overlapping sheet is installed, inspect joint for gaps and fill with additional sealant.

FASTENER OPTIONS

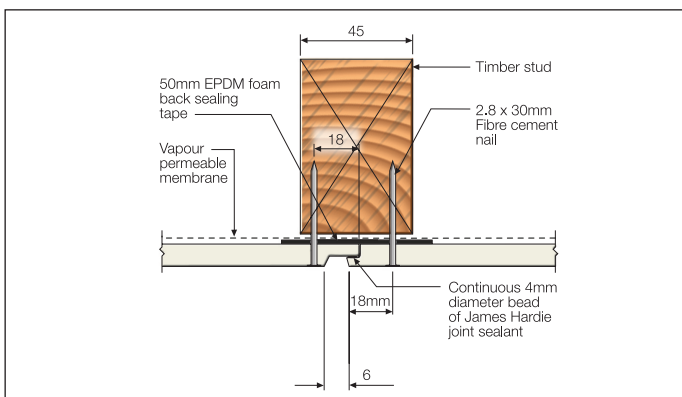

FIGURE 11 FIBRE CEMENT NAIL FIXING

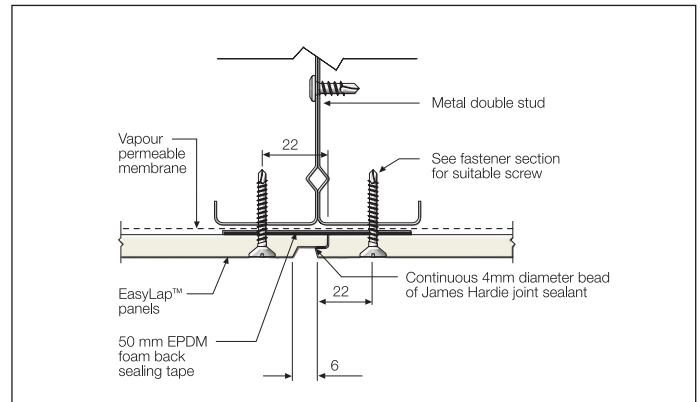

FIGURE 12 SHEET JOINT ON STEEL - FLUSH SCREW OPTION

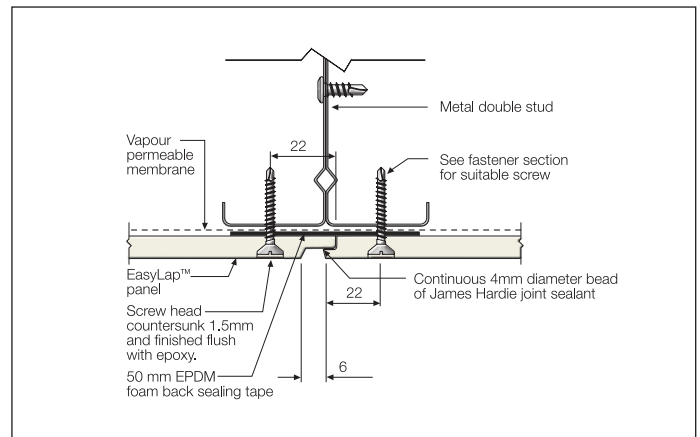

FIGURE 13 COUNTERSUNK SCREW OPTION

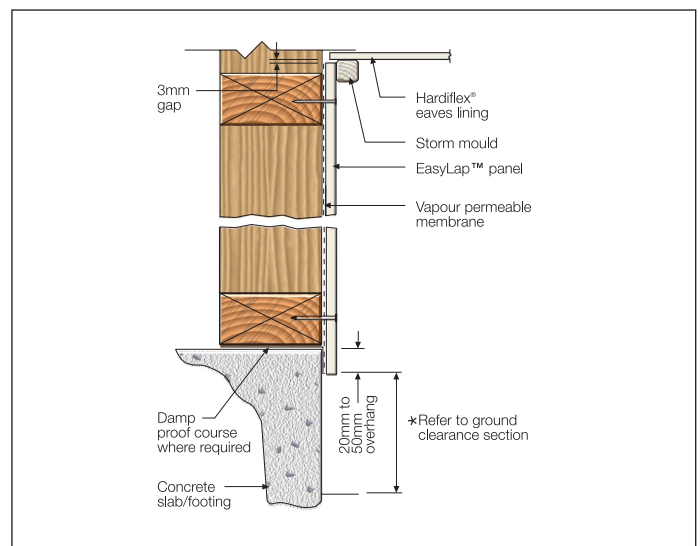

FIGURE 14 SLAB/EAVE JUNCTION DETAIL

5 DETAILS

WINDOW DETAILS

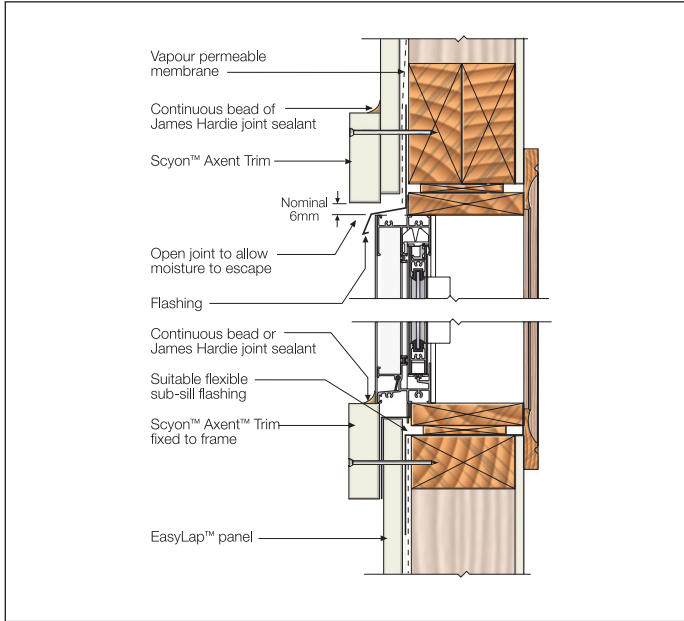

FIGURE 15 WINDOW HEAD AND SILL - TRIM

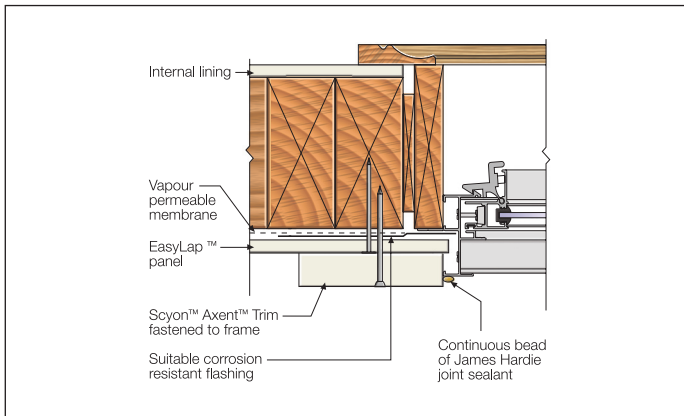

FIGURE 16 WINDOW JAMB - TRIM

EXTERNAL CORNER DETAILS

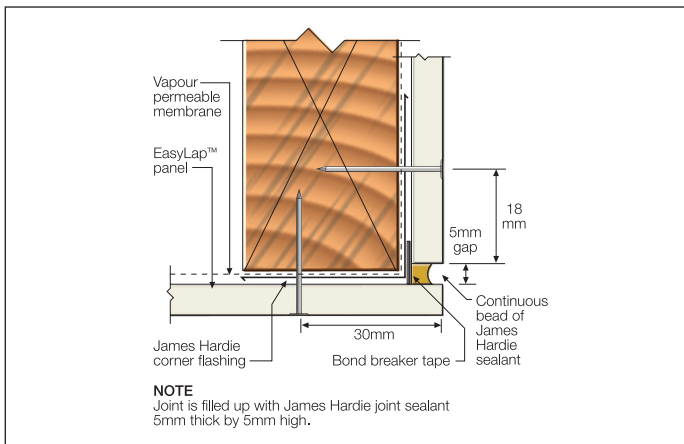

FIGURE 17 SEALANT FILL OPTION

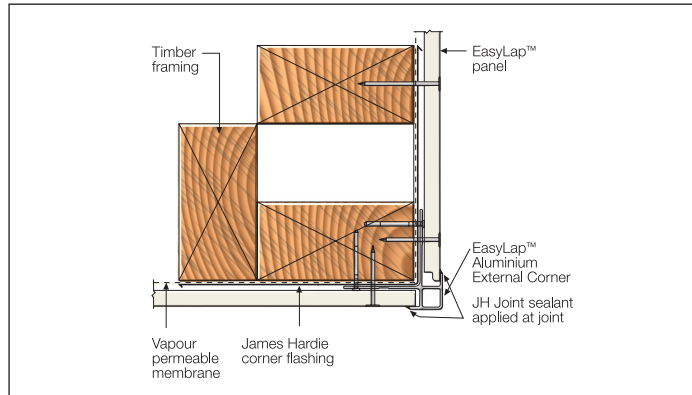

FIGURE 18 ALUMINIUM BOX CORNER OPTION

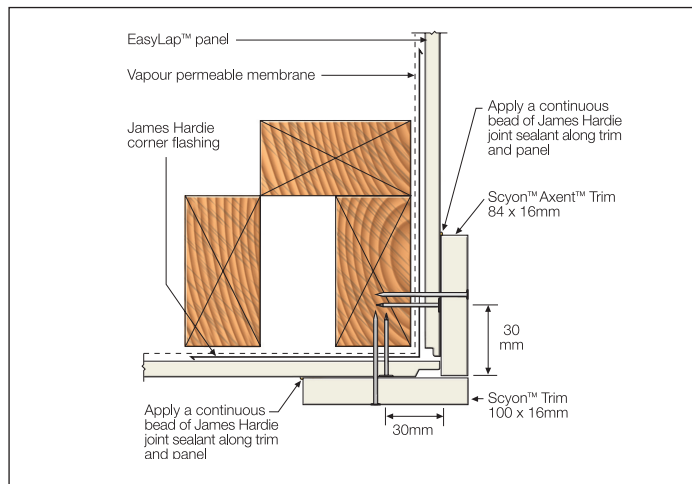

FIGURE 19 TRIM CORNER OPTION

INTERNAL CORNER DETAILS

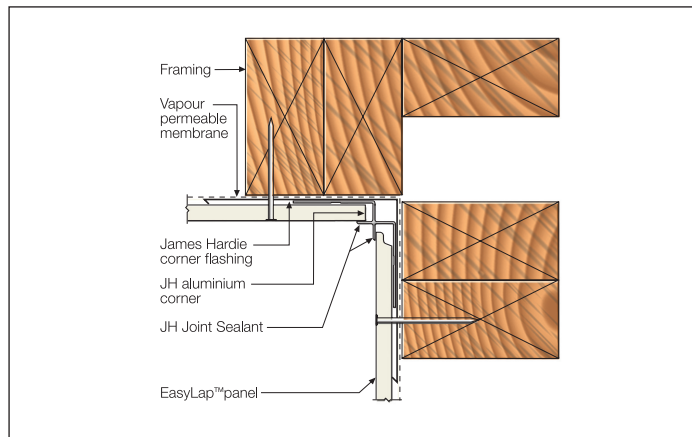

FIGURE 20 ALUMINIUM CORNER DETAIL

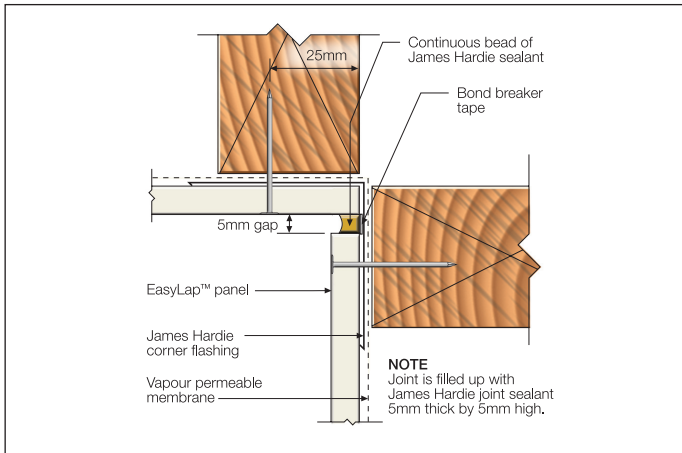

FIGURE 21 SEALANT FILL OPTION

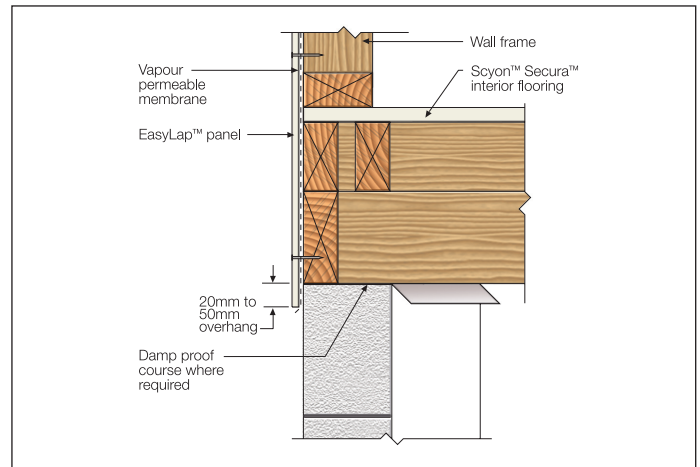

FIGURE 24 LOWER FLOOR JUNCTION

The EasyLap™ panels must not continue over a floor junction or where excessive movement or creep will occur, see Figures 25 and 26.

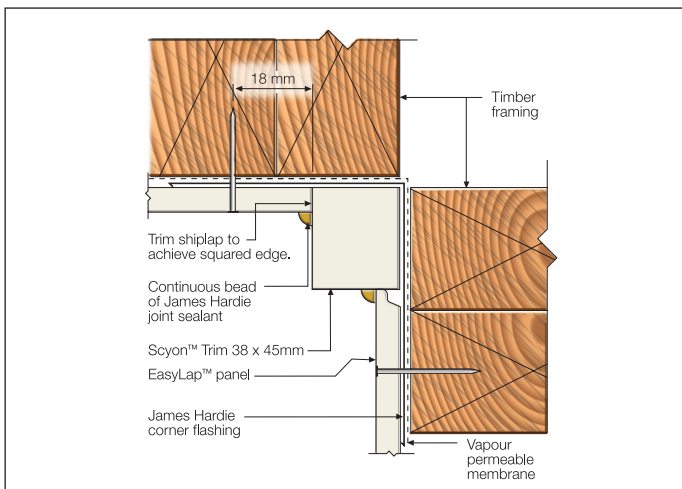

FIGURE 22 TRIM CORNER OPTION

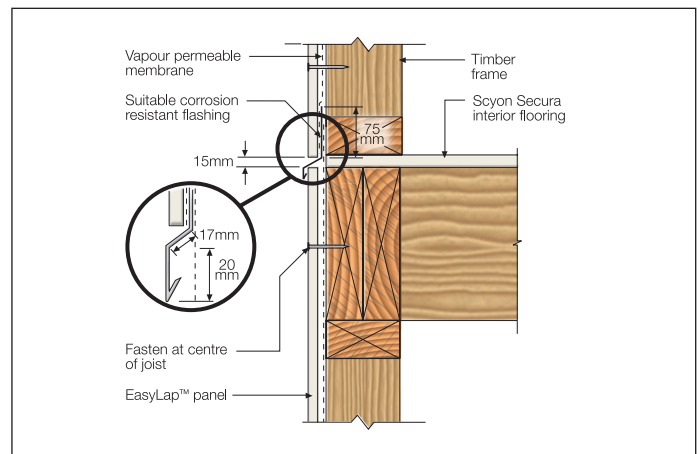

FIGURE 25 UPPER FLOOR JUNCTION

JUNCTION DETAILS

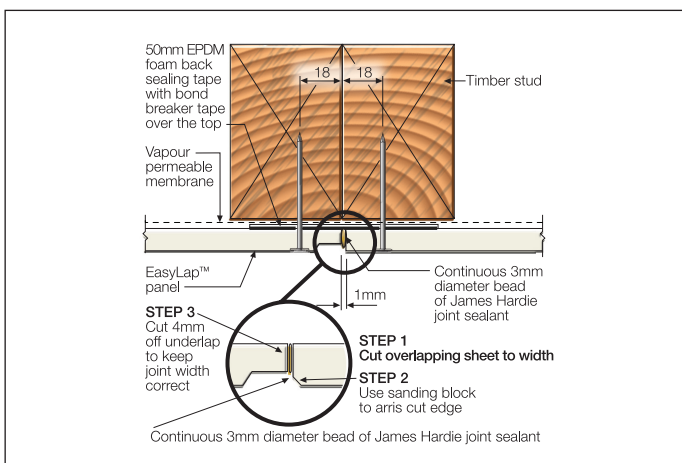

FIGURE 23 VERTICAL BUTT JOINT

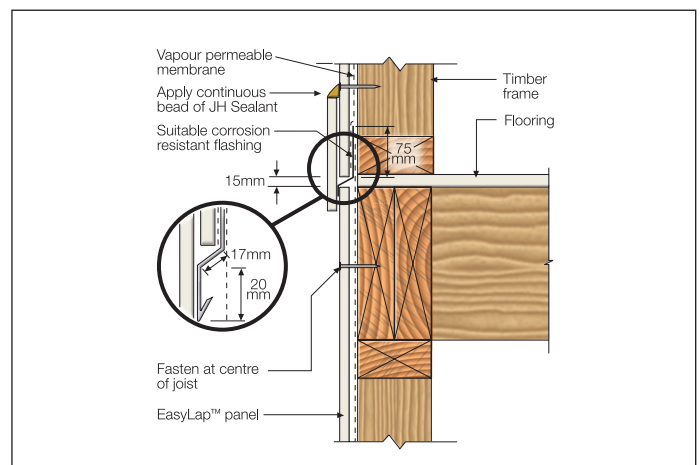

FIGURE 26 UPPER FLOOR JUNCTION OPTION 2

6 FINISHES AND MAINTENANCE

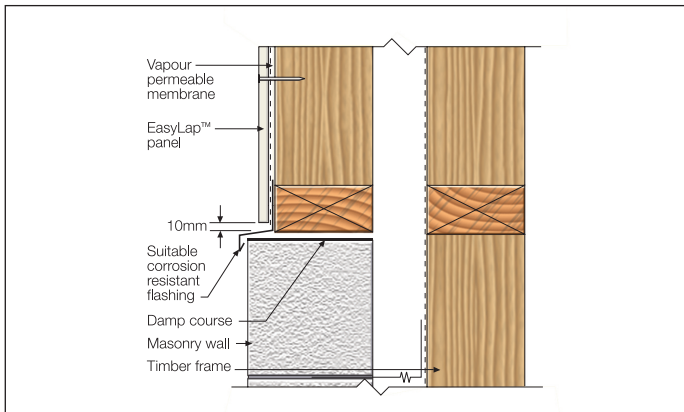

FIGURE 27 HORIZONTAL JUNCTION 1

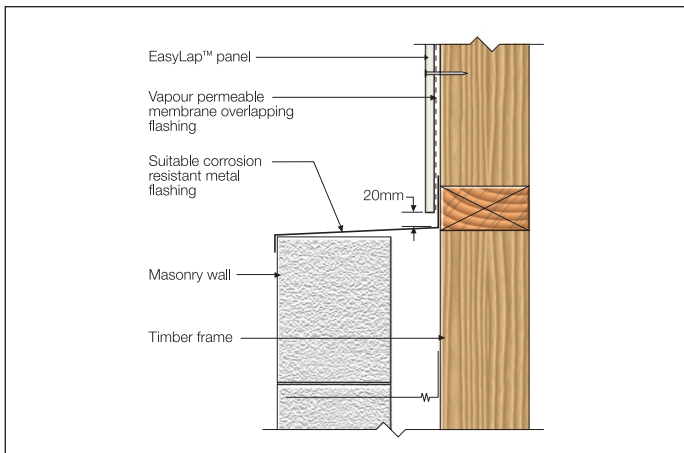

FIGURE 28 HORIZONTAL JUNCTION 2

FINISHING

Sealant

Application and use of sealants must comply with manufacturer's instructions. Sealants, if coated, must be compatible with the paint system.

Painting

EasyLap™ panels are ready for texture. All sheets must be dry before painting.

Refer to the project specification for paint requirements. EasyLap™ panels must be finished with texture paint within 3 months of being fixed. In areas within 1km of a coastal area or corrosive environment, the EasyLap™ panels must be painted immediately after fixing sheets to minimise contamination build up on the heads of the fasteners, as it may lead to fastener corrosion.

James Hardie recommends the application of a roll on exterior texture coat system over the panels in accordance with the paint manufacturer's specifications. Some environments require special coatings including coastal areas. Painting selection and specifications are dependant on the paint chosen. Refer to the paint manufacturer for further information, product suitability, specifications, maintenance and details of their warranty.

Staining

Stains containing linseed oil are specifically designed for wood and may not be suitable for James Hardie cladding products, primed or un-primed.

Semi-transparent stains can vary in uniformity of appearance depending on method of application and conditions and will require a high level of skill and craftsmanship to achieve a uniform appearance. Clear coats have not proven durable in exterior exposure and James Hardie considers them a maintenance item that may require application of a refurbishing sealer at regular intervals. James Hardie does not warrant the appearance or durability of semi-transparent stains and clear coats.

MAINTENANCE

The extent and nature of maintenance will depend on the geographical location and exposure of the building. As a guide, it is recommended that basic normal maintenance tasks shall include but not be limited to:

- Washing down exterior surfaces every 6-12 months*
- Periodic inspections should be made to ensure fasteners are adequately securing the sheets to framing.
- Re-applying of exterior protective finishes*
- Maintaining the exterior envelope and connections including joints, penetrations, flashings and sealants that may provide a means of moisture entry beyond the exterior cladding.
- Cleaning out gutters, blocked pipes and overflows as required.
- Pruning back vegetation that is close to or touching the building.

*Refer to your paint manufacturer for washing down and recoating requirements related to paint performance.

7 PRODUCT INFORMATION

PRODUCT INFORMATION

Material

The basic composition is Portland cement, ground sand, cellulose fibre and water. James Hardie building products are manufactured to Australian/New Zealand Standard AS/NZS 2908.2 'Cellulose-cement products-Flat sheet.'

EasyLap™ panels are classified Type A, Category 3 in accordance with AS/NZS 2908.2.

Durability

Resistance to moisture/rotting

EasyLap™ panels have demonstrated resistance to permanent moisture induced deterioration (rotting) by passing the following tests in accordance with AS/NZS 2908.2:

- Water permeability (Clause 8.2.2)
- Heat rain (Clause 6.5)
- Warm water (Clause 8.2.4)
- Soak dry (Clause 8.2.5)

Resistance to termite attack

Based on testing completed by CSIRO Division of Forest Products and Ensis Australia James Hardie building products have demonstrated resistance to termite attack.

Resistance to fire

EasyLap™ panels are suitable where non-combustible materials are required in accordance with C1.12 and part 3.7.1.2 of the Building Code of Australia.

James Hardie building products have been tested to AS/ISO 9239, and exceed the requirements stipulated in the Building Code of Australia. - Specification C1.10a Fire Hazard Properties – Floors, Walls & Ceilings.

Building Code of Australia Requirement	BCA Requirement	Documented Test Result
Critical Radiant Flux	Not less than 4.5kW/m ² (highest value in accordance with Table 1)	11.5kW/m ²
Maximum smoke development rate	750%.minutes	16%.minutes

Alpine regions

In regions subject to freezing conditions, James Hardie external claddings must be painted immediately and the cladding only installed in the warmer parts of the year. In addition, the cladding must not be in direct contact with snow/or ice build e.g. external walls in alpine regions subject to snow drifts over winter.

Tested to AS/NZS 2908.2 Clause 8.2.3

8 WARRANTY

WARRANTY

James Hardie Australia Pty Limited ("James Hardie") warrants to the first purchaser of the Product and the last purchaser prior to the installation of the Product for a period of 10 years from the date of purchase that EasyLap™ panels (the "Product") will be free from defects due to defective factory workmanship or materials and, subject to compliance with the conditions below, will be resistant to cracking, rotting, fire and damage from termite attacks to the extent set out in James Hardie's relevant published literature current at the time of installation. James Hardie warrants for a period of 12 months from the date of purchase that

the accessories supplied by James Hardie will be free from defects due to defective factory workmanship or materials.

Nothing in this document shall exclude or modify any legal rights a customer may have under the Trade Practices Act or otherwise which cannot be excluded or modified at law.

Conditions of Warranty

The warranty is strictly subject to the following conditions:

- (a) James Hardie will not be liable for breach of warranty unless the claimant provides proof of purchase and makes a written claim either within 30 days after the defect would have become reasonably apparent or, if the defect was reasonably apparent prior to installation, then the claim must be made prior to installation;
- (b) this warranty is not transferable;
- (c) the Product must be installed and maintained strictly in accordance with the relevant James Hardie literature current at the time of installation and must be installed in conjunction with the components or products specified in the literature. To obtain copies of such literature contact Ask James Hardie™ on 13 11 03. Further, all other products, including coating and jointing systems, applied to or used in conjunction with the Product must be applied or installed and maintained strictly in accordance with the relevant manufacturer's instructions and good trade practice;
- (d) the project must be designed and constructed in strict compliance with all relevant provisions of the current Building Code of Australia, regulations and standards;
- (e) the claimant's sole remedy for breach of warranty is (at James Hardie's option) that James Hardie will either supply replacement product, rectify the affected product or pay for the cost of the replacement or rectification of the affected product;
- (f) James Hardie will not be liable for any losses or damages (whether direct or indirect) including property damage or personal injury, consequential loss, economic loss or loss of profits, arising in contract or negligence or howsoever arising. Without limiting the foregoing, James Hardie will not be liable for any claims, damages or defects arising from or in any way attributable to poor workmanship, poor design or detailing, settlement or structural movement and/or movement of materials to which the Product is attached, incorrect design of the structure, acts of God including but not limited to earthquakes, cyclones, floods or other severe weather conditions or unusual climatic conditions, efflorescence or performance of paint/coatings applied to the Product, normal wear and tear, growth of mould, mildew, fungi, bacteria, or any organism on any Product surface or Product (whether on the exposed or unexposed surfaces);
- (g) all warranties, conditions, liabilities and obligations other than those specified in this warranty are excluded to the fullest extent allowed by law;
- (h) if meeting a claim under this warranty involves re-coating of Products, there may be slight colour differences between the original and replacement Products due to the effects of weathering and variations in materials over time.

DISCLAIMER

The recommendations in James Hardie's literature are based on good building practice, but are not an exhaustive statement of all relevant information and are subject to conditions (c), (d), (f) and (g) above. Further, as the successful performance of the relevant system depends on numerous factors outside the control of James Hardie (eg quality of workmanship and design), James Hardie shall not be liable for the recommendations in that literature and the performance of the relevant system, including its suitability for any purpose or ability to satisfy the relevant provisions of the Building Code of Australia, regulations and standards.

For more information please Ask James Hardie™ on 13 11 03 or visit www.jameshardie.com.au

Ask James Hardie™
Call 13 11 03
www.jameshardie.com.au

COPYRIGHT JULY 2009
© JAMES HARDIE AUSTRALIA PTY LTD ABN 12 084 635 558
™ AND © DENOTES A TRADEMARK OR REGISTERED MARK
OWNED BY JAMES HARDIE INTERNATIONAL FINANCE BV.

JHML112633