



InSinkErator®

Product List

Food Waste Disposers

Steaming Hot
Water Taps



Food Waste Disposers

Evolution 200
0.75hp



Evolution 100
0.70hp



Model 65
0.65hp



Model 55
0.55hp



Model 45
0.5hp



Accessories



Air Switches

For continuous feed units only. Air switch for models 45 and 55 supplied with chrome and brushed steel button (cutout size 33mm diameter).



Extended flange

For use with sinks greater than 20mm thickness.



Cover control

For Evolution models 100 and 200. For batch feed conversion only.

	Evolution 200	Evolution 100	Model 65	Model 55	Model 45
Sound Reduction Technology	-60%	-40%	-20%	Basic	Standard
Number Of Grind Stages	3X	2X	1X	1X	1X
Horsepower	.75 HP	.70 HP	.65 HP	.55 HP	.45 HP
Warranty	6 Years	5 Years	4 Years	3 Years	2 Years
Built In Air Switch	Yes	Yes	Yes	No	No
Power Booster Circuit With Microprocessor	Yes	No	No	No	No
Stainless Steel Strainer Basket	Yes	Yes	No	No	No
Can Accommodate Cover Control Accessory	Yes	Yes	No	No	No
Grind Chamber Capacity	1180ml (stainless steel)	1005ml	980ml	980ml	980ml
Stainless Steel Grinding Elements	Yes	Yes	Yes	Yes	No

*All food waste disposer models use the exclusive InSinkErator induction motor designed for power, performance and quietness, whatever the load.

Steaming hot water taps

HC3300
Hot & cold filtered water

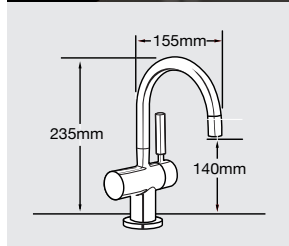

H3300
Hot filtered water only

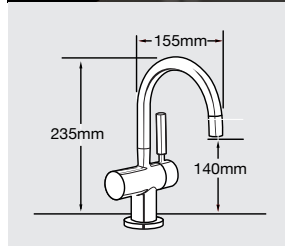

HC1100
Hot & cold filtered water

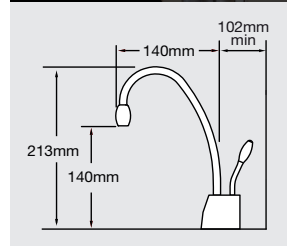

GN1100
Hot filtered water only

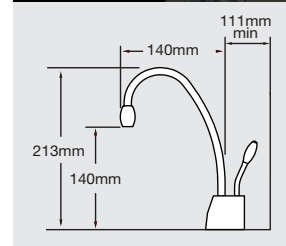

F-701R
Water filter



F-701R filter will come standard with all taps. It is a chlorine, taste and odour filter with additional lead protection and a scale reduction capability. It filters sediment at a 5 micron level. Sold as a replacement filter in a two pack carton.

Tank illustration

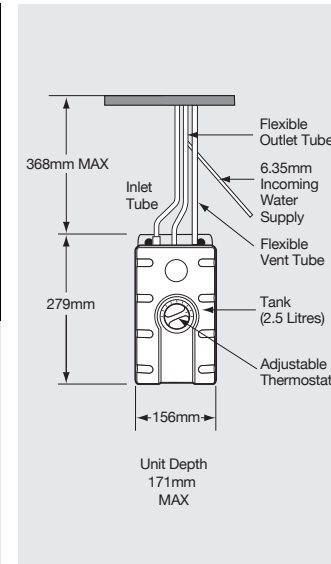

Tap finishes



Brushed steel finish



Polished chrome

Water filters come in packs of two.

Tap Specification	HC3300	H3300	HC1100	GN1100
Capacity	2.5 Litre Stainless Steel tank dispenses approximately 100 cups of 98°C water per hour			
Electrical	220-240 volts A.C. 1300 watts, heating element with grounded plug. Requires 10 amps of power			
Thermostat	Electronic, adjustable from 88°C to 98°C (factory pre-set at 96°C)			
Insulation	Meets U.L. 94HF - 1 flammability specification			
Hot Valve	Push hot side activation with automatic shut off (OptiPust)		Instant, self closing	
Cold Valve	Manual return	n/a	Manual return	n/a
Weight	Approximately 4.4kg		Approximately 4.4kg	
Required Hole Diameter	35mm-38mm		35mm-38mm	32mm-38mm
Required Supply Pressure	172-862 kPa (1.7-8.6 bar) (25-125 psi)			

Filter Specification	F-701R
Chemical & Mechanical Reduction Filter Specifications	This provides mechanical and chemical reduction of dirt/rust, taste/odour, chlorine, lead and particulates. Also reduces scale formation by hardness and alkalinity.
Caution	Use with only microbiologically safe drinking water
Warning	For correct operation of this appliance, it is essential to observe the manufacturer's instructions. Do not install where freezing may occur.
Cold water pressure	172-862 kPa (1.7-8.6 bar) (25-125 psi)
Water temperature	0.6°C-38°C (33°F-100°F)
Flow Rate	2.84 lpm (0.75 gpm)
Capacity	454 litres (120 gallons)



Food Waste Disposers

InSinkErator offers a range of five models each with different features, all offering excellent levels of performance and reliability. Thanks to the introduction of our Evolution® 200 and Evolution 100 models, the range is now quieter and more powerful than ever before. Featuring two and three stages of grind technology, the new Evolution models are the finest grinding disposers available. Evolution quiet technology features a quiet operation up to 60% quieter than the standard disposer. Evolution models incorporate air switches.

Our standard range of models (45, 55, 65) offer good performance, continuous feed operation, and the ability to handle varying amounts of food waste. The model 65 incorporates an air switch and models 45 and 55 have an air switch valve as an accessory.

Features

- Compact design
- Auto-reverse grinding action on selected models
- Quick-Lock™ mounting assembly for faster, easier installation
- Overload protection
- Stainless steel grind elements (all models except model 45)
- High-torque Dura-drive induction motor
- 2–6 year full warranty (dependent on model)
- Sound-Seal and multi-grind technology (dependent on model)

Benefits

- Food waste is ground into fine particles and flushed away in seconds.
- Clean, hygienic, convenient and simple to use
- Easy method to manage food waste in the home, saving you time and helping to minimise trips to the outside dustbin
- Permanent in-house solution that is compact and sits under the sink without taking up valuable storage
- Easy to install into new or existing kitchens and can be fitted to most sinks
- Environmentally responsible, helping reduce the amount of waste that goes to landfill sites



Steaming Hot Water Taps

The new HC3300 and H3300 are stylish additions to the InSinkErator range and have been created to compliment contemporary kitchen designs. Both taps dispense hot water using a unique single handle and benefit from an automatic hot push-lever locking mechanism. The HC3300 also provides ambient cold filtered water.

Providing a touch of elegance to any kitchen, the HC1100 and GN1100 taps also provide instant hot water at the touch of a lever with additional ambient cold filtered water from the HC1100. The 1100 models also benefit from an instant self closing hot water valve that ensures automatic shut off.

Water Filters

InSinkErator water filters are designed exclusively for use with the InSinkErator Steaming Hot Water Tap system.

Features

- Elegant spout swivels for convenience
- A gentle touch, one lever dispenser
- Shut off valve built into filter head to automatically stop water flow
- Instant self closing hot water valve that ensures automatic shut-off
- Tap insulated from heat expansion
- Tap mounted on either the kitchen work surface or sink
- Unobtrusive 2.5 litre stainless steel tank fitted under sink
- Easy, no mess, replaceable filter
- Adjustable temperature dial
- Plugs directly into electrical power point located close to appliance
- Compact design
- Two year full warranty

Benefits

- 98°C steaming hot and ambient cold filtered water instantly
- Produces approximately 100 cups of steaming hot water per hour
- Safe, filtered drinking water
- Reduces chlorine, lead, turbidity and other unpleasant tastes and odours from water
- Efficient and time saving
- Special scale reduction technology to protect heating elements in hard water
- Better tasting filtered drinking water
- Time-tested quality
- Replaces the kettle for a clutter-free aesthetically pleasing worktop

InSinkErator
471 Mountain Hwy,
Bayswater Vic 3153, Australia
Sales/Service Tel: 1300 136 205
Fax: (03) 9720 3178

InSinkErator reserves the right to change product specification without prior notice. All products are for household use: usage in commercial situations is not covered by warranty

in sink erator[®]
solutions for sinks

EMERSON
Appliance Solutions

The Emerson logo is a trademark and service mark of Emerson Electric Co. InSinkErator is a division of Emerson Electric Co. Patents Pending.