

# EZYjamb®



**CLEAN LINES! ...**

The Flush Finish Door Jamb System

**EZYjamb**

# EZY Jamb<sup>®</sup>



## FLUSH FINISH DOOR JAMB SYSTEM

For many years, architects, interior designers and developers have been trying to produce a contemporary flush finish door jamb with clean lines and inconspicuous detail. Ezy-Jamb does just that!

Ezy-Jamb is a split-type jamb manufactured from cold rolled steel with a patented profile to produce a strong and secure assembly. The jamb comes with perforated sides for flush jointing giving the doorway a clean line look.

## Installation

Ezy-Jamb is simple to install, and it requires no special maintenance. The jamb is a split-type and comes in two sections that fit neatly together and provides adjustability in wall thickness. The system is complemented by a range of hardware to suit different applications.



**CLEAN LINES! ...** The Flush Finish Door Jamb System

Clean. Lines.

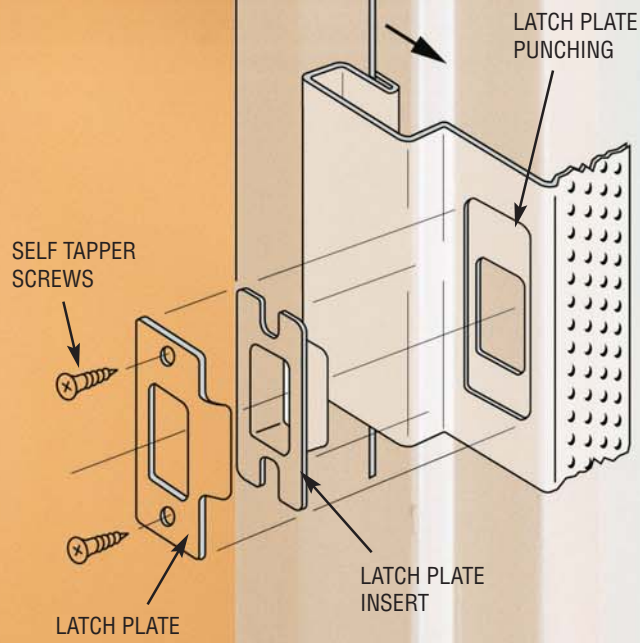
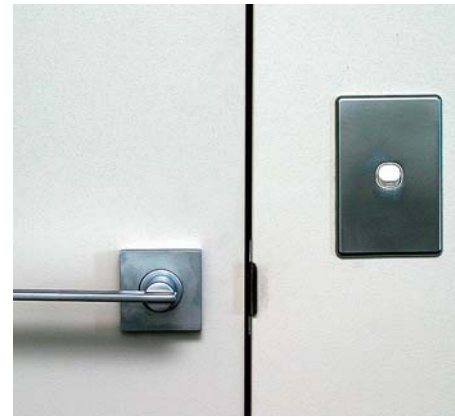

## Flush Finish

The completed jamb is flush finished and can be painted in with the whole wall area to fully conceal any fixing, achieving simple clean lines around the door face. The incorporation of reinforced edges overcomes the continual damage door jambs are subjected to by normal everyday use.

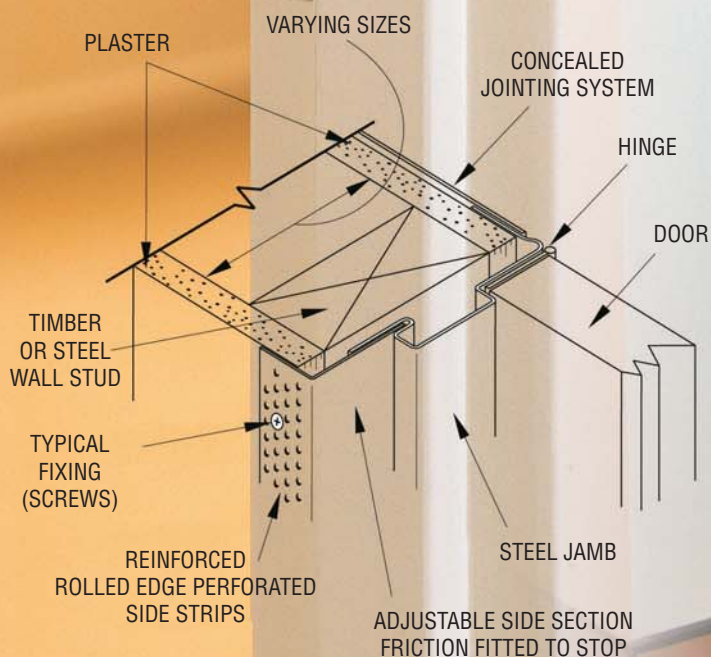

**EZY** jamb

Residential

# HOMES



**EZYjamb**<sup>®</sup>

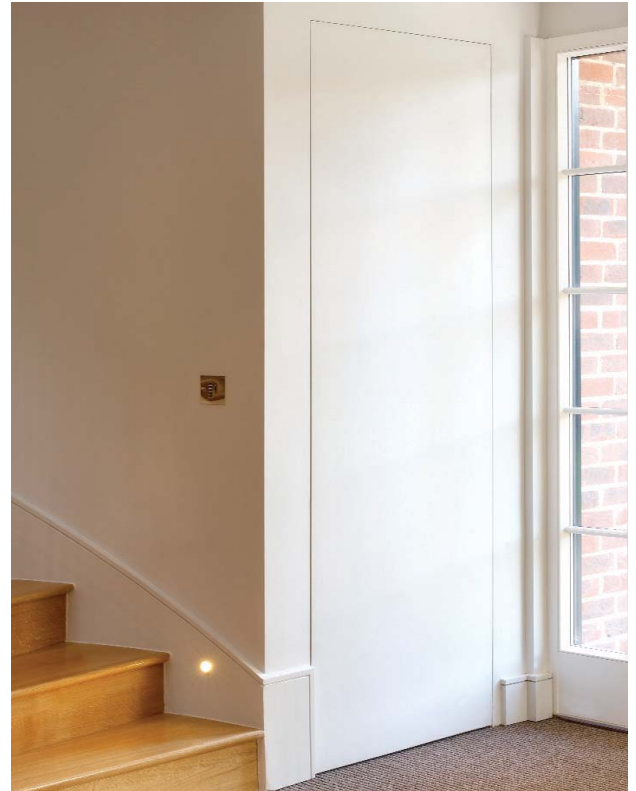

**CLEAN LINES!** ... The Flush Finish Door Jamb System



**Architrave free doors...**

**Make a statement, clean lines, flush finish...**

**Give your project a clean cut edge!**

# Residential

Ezy-Jamb...The choice for developers the world over... Giving the doorway to your world a sense of a stark, clean environment.



<sup>®</sup>  
**EZY Jamb**

## UNITS



**CLEAN LINES! ...** The Flush Finish Door Jamb System



# APARTMENTS

Full height doors, cavity sliders for small footprint requirements allowing for a sense of uncluttered freedom with the clean line flush finish look.



Commercial



The unique design of the Ezy-Jamb System combines visual appeal, strength and versatility for a commercial environment.



# OFFICES



<sup>®</sup>  
**EZYjamb**



# SHOWROOMS



**CLEAN LINES! ...** The Flush Finish Door Jamb System



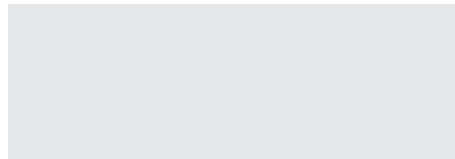
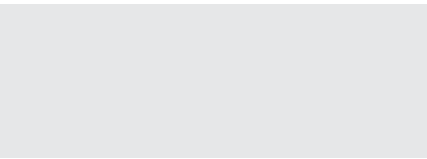
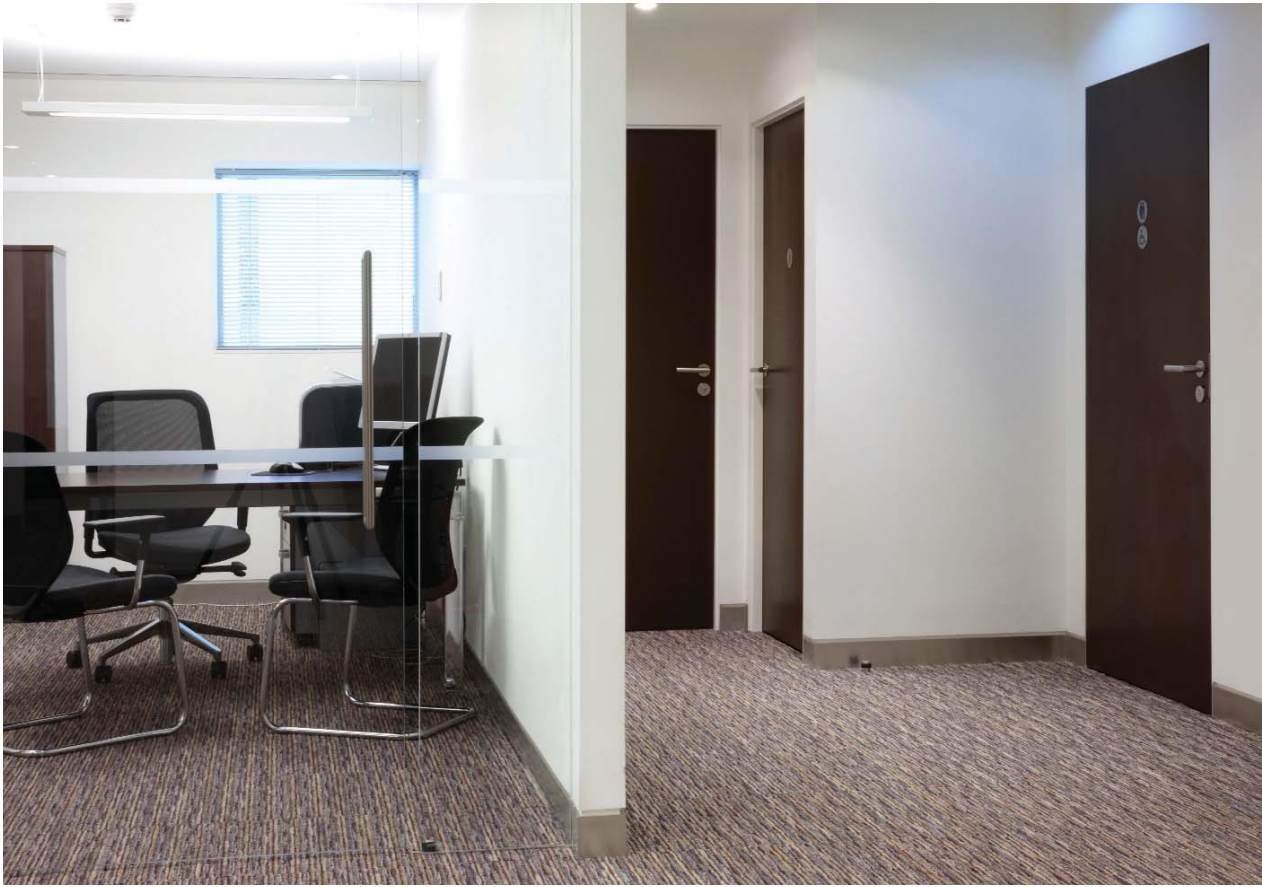

# HEALTH CARE



# Cavity Slider Unit

# EZY Jamb®

## CAVITY SLIDER SYSTEM

Studco Building Systems offers the Ezy-Jamb Flush Finish Cavity Sliding System with Head Jamb or Full Height Detail.

The full height detail is designed to allow the underside of the track to finish with the ceiling, providing a smooth continuous flow from room to room. Along with this, the Ezy-Jamb Flush Finish Cavity Sliding System offers a totally square set finish around the perimeter of the frame giving a seamless transition through living areas.

The **Ezy-Jamb Flush Finish Cavity Sliding System** has been designed to provide the absolute minimum of detail giving the ability to completely conceal the door and give the impression that the door does not exist when open, and complete privacy when closed, adding a contemporary and architectural dimension to any project.

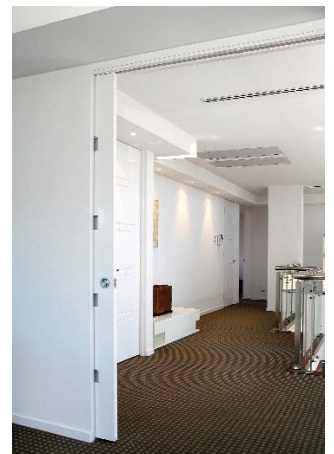

### STUD THICKNESS

90mm or 92mm

### PLASTER THICKNESS

10mm or 13mm

### DOOR SIZE

height up to 3000mm width up to 2000mm

thickness 35mm or 40mm

### Ezy-Jamb Full Height Detail

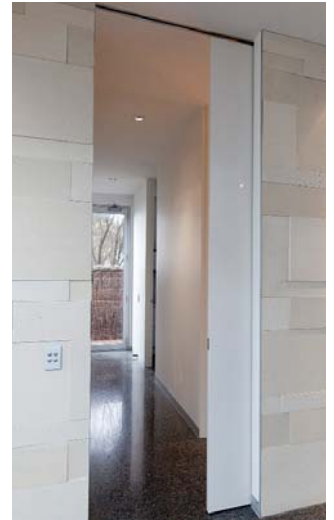
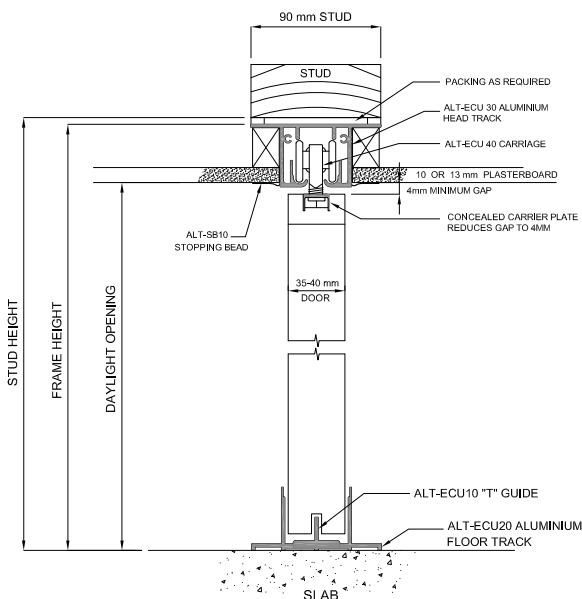

**CLEAN LINES! ...** The Flush Finish Door Jamb System

# cavkit

*Cavity Slider Kits*

## The Flush Finish Cavity Slider Kit

Cavkit can be used to transform standard cavity sliders into architrave free, flush finish cavity sliders. This also complements and tones in with the Ezyjamb® flush finish door jamb system. The Cavkit is made up of Ezyreveal® and Ezycap® to trim and cap the plaster edges around the door penetration. Optional custom made closer cap can be produced to suit any specification to provide total privacy.

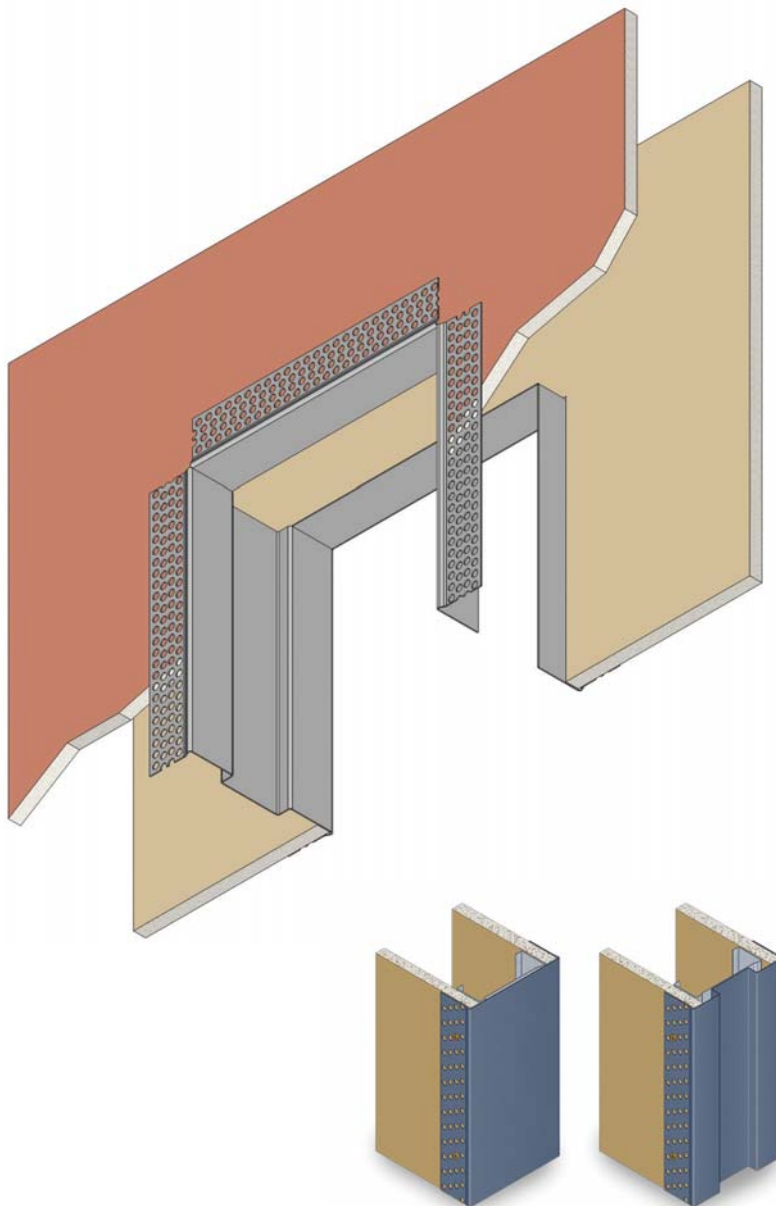

Standard EZY CAP

Custom CLOSER CAP

Cavkit.  
Trims only



**EZY** jamb

# Hinges



## HERLINE HINGES

Ezy-Jamb stainless steel loose pin herline hinges are offered with the Ezy-Jamb system. These hinges are surface mounted with self tapping screws making for easy installation. Lift off hinges and lift off channels available.



## CONCEALED HINGES

Ezy-Jamb concealed hinges allow for a totally flush finish door without the barrel of the hinge protruding out. This creates a look of the door floating within the Ezy-Jamb.



**CLEAN LINES!** ... The Flush Finish Door Jamb System

# Section Details

## SECTION DETAILS

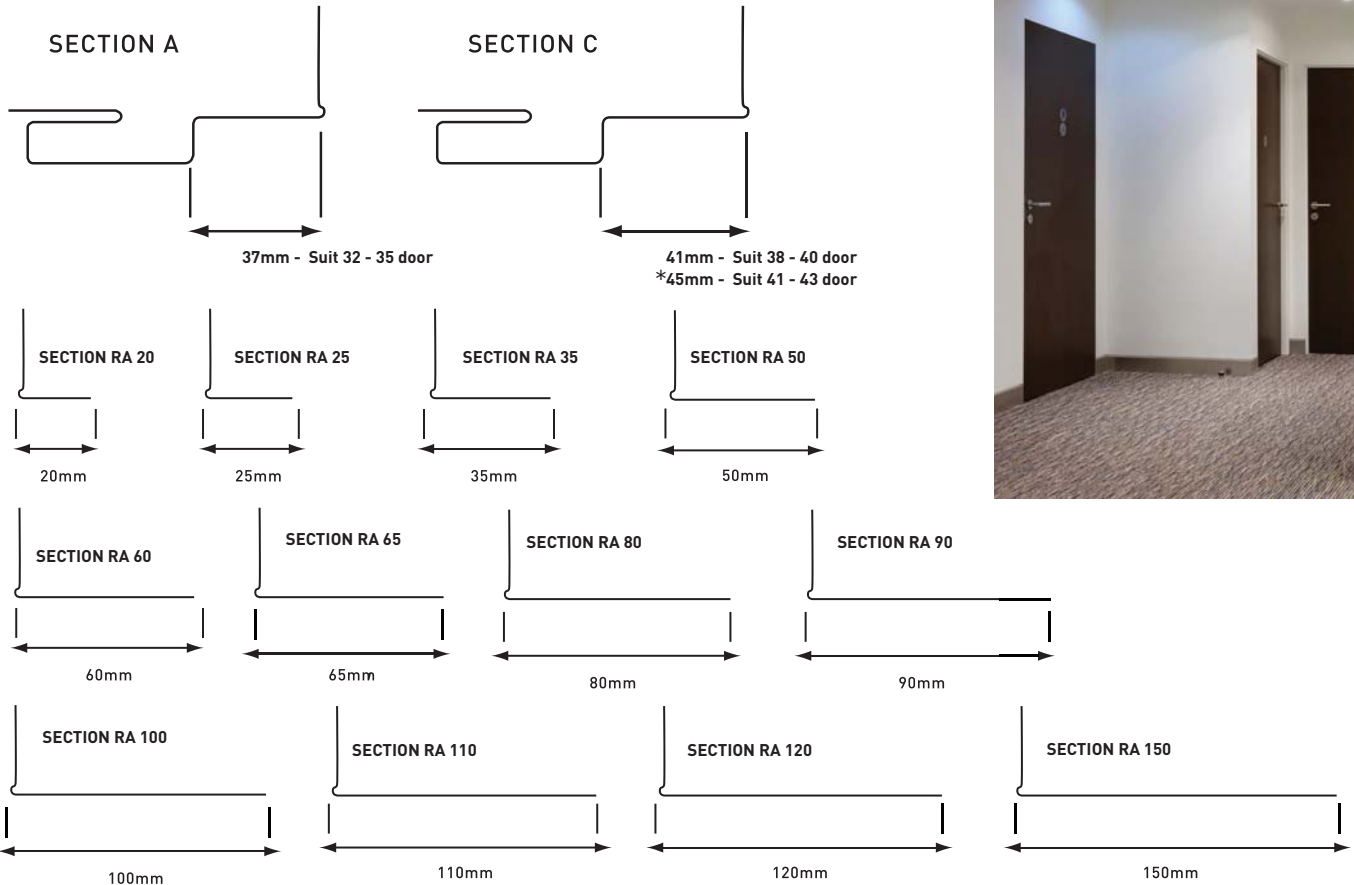

SECTION A COMBINATIONS	FINISHED WALL TOLERANCES	
	MINIMUM	MAXIMUM
SECTION A & RA20	76MM	86MM
SECTION A & RA25	81MM	91MM
SECTION A & RA35	91MM	101MM
SECTION A & RA50	106MM	116MM
SECTION A & RA60	116MM	126MM
SECTION A & RA65	121MM	131MM
SECTION A & RA75	131MM	141MM
SECTION A & RA80	136MM	146MM
SECTION A & RA90	146MM	156MM
SECTION A & RA100	156MM	166MM
SECTION A & RA110	166MM	176MM
SECTION A & RA120	176MM	186MM
SECTION A & RA150	206MM	216MM

SECTION C COMBINATIONS	FINISHED WALL TOLERANCES	
	MINIMUM	MAXIMUM
SECTION C & RA20	80MM	90MM
SECTION C & RA25	85MM	95MM
SECTION C & RA35	95MM	105MM
SECTION C & RA50	110MM	120MM
SECTION C & RA60	120MM	130MM
SECTION C & RA65	125MM	135MM
SECTION C & RA75	135MM	145MM
SECTION C & RA80	140MM	150MM
SECTION C & RA90	150MM	160MM
SECTION C & RA100	160MM	170MM
SECTION C & RA110	170MM	180MM
SECTION C & RA120	180MM	190MM
SECTION C & RA150	210MM	220MM

\*Lead times apply

\*Custom sizes to suit larger wall thicknesses available.

## Ezyfinishing

# EZY reveal

- Designed for quick and economical finishing of reveal from 20 to 150mm.
- Manufactured from cold rolled steel providing a strong and secure reveal eliminating warping, twisting, cracking and damage from UV Rays.
- Enquire for custom size reveal lengths

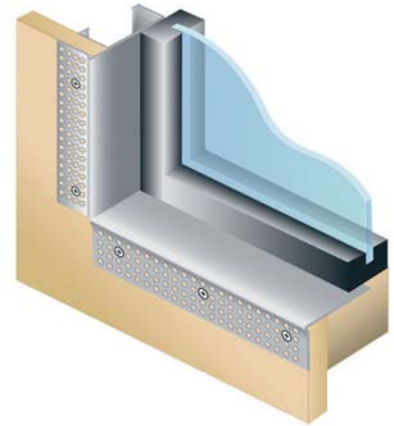
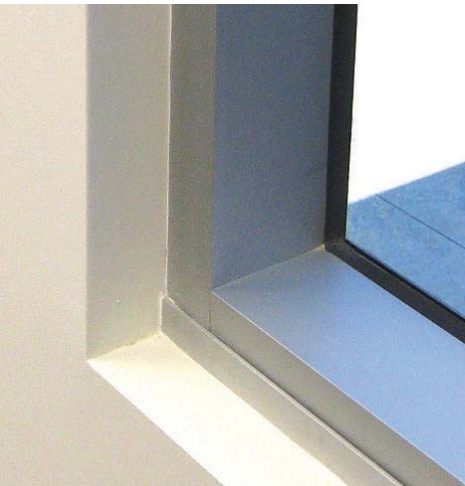

**Quick and economical finishing of reveals**

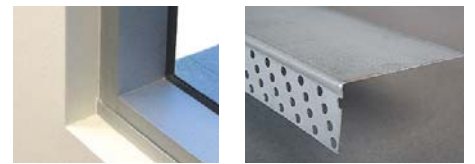

## EZY cap

**The strong and versatile alternative for stop ends**



- Designed for quick and economical finishing of wall ends.
- Manufactured from cold rolled steel providing a strong and secure wall and end cap that is both durable and fast to install.
- Hard to reach wall ends made possible with Ezycap®.
- Available in a range of sizes to suit various wall configurations.



**CLEAN LINES! ... The Flush Finish Door Jamb System**

# Aluminium Skirting

- Contemporary, robust skirting for simple modern clean line appearance.
- Excellent resilience to wear, with good impact resistance
- Retains strength and requires minimal maintenance

SK80-36	80mm x 1.6	Flat Natural Anodised Aluminium Skirting
SK100-36	100mm x 1.6	Flat Natural Anodised Aluminium Skirting
SK100BL-36	100mm	Natural Anodised Direct Screw Fix Skirting

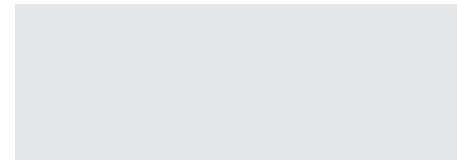
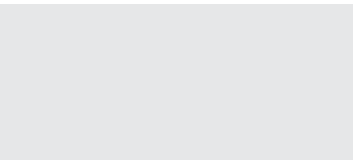

fastcap

## Rebates....Fastcap is the answer.

Custom finishing and capping of plasterboard is made easy with the Fastcap range of custom finishing sections.

Custom finishing and capping of plasterboard is made easy with Fastcaps® range of custom made finishing sections. Our custom design and consultancy team is ready to help design and produce an innovative solution to your requirements for any size project. Fastcaps® custom finishing sections make the finishing of difficult plasterboard profiles, rebates and large oversized shadowlines a dream.

- Light troffers
- Recessed curtain pelmets
- Ceiling features
- Sliding door receptacle
- Flush-finish bookshelves
- Recessed wall features

**Enquire now for a fast solution to all your requirements.**



**EZY** jamb

# EZY Jamb®

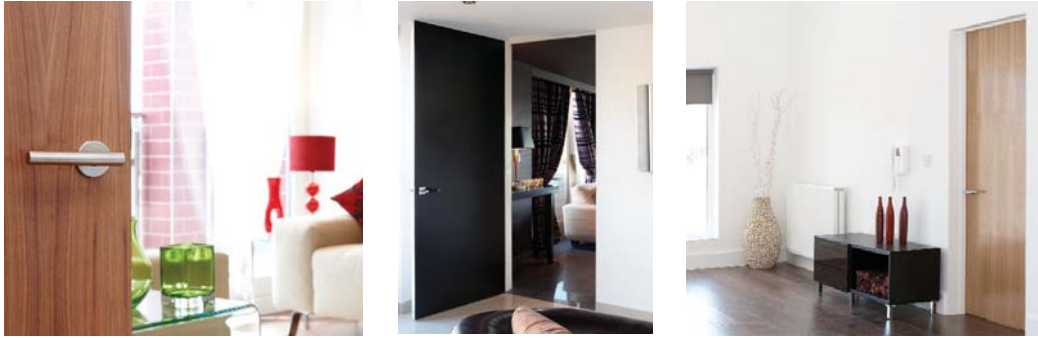

**Available in Australia, New Zealand, USA, UK and Europe.**

Email: [sales@ezyjamb.com.au](mailto:sales@ezyjamb.com.au)

Web: [www.ezyjamb.com.au](http://www.ezyjamb.com.au)

*Ring for nearest Distributor*

**Customer Service Hotline**

**1300 EZY JAMB**

MANUFACTURED BY:

**STUDCO**  
**BUILDING SYSTEMS**

**CLEAN LINES! ...** The Flush Finish Door Jamb System