

CORA BIKERACK

Commercial Bicycle Parking Products

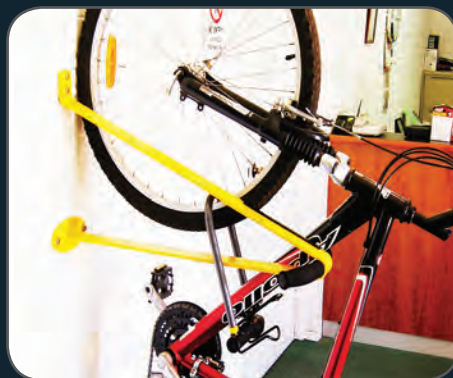

About Us

Cora Bike Rack is a family owned business that has been devoted to improving Australia's cycling infrastructure since 1997.

We are also cycling enthusiasts and believe that by designing better bicycle parking products, people will want to ride their bikes to more places, more often – and that's a good thing for everyone!

We design all of our bicycle racks and lockers to be easy to use, easy to install and nice to look at. We proudly manufacture all of our commercial bike racks right here in Australia.

If you are an Architect or Builder, we understand new DA conditions and Green Star requirements that now require AS2890.3 and Green Star compliant bicycle parking facilities.

Cora Bike Rack provides professional advice to guide you through the standards, select the best products, create the most space efficient layout and ensure your project is a success.

If you are a Local Council, Transport Authority, Building Manager, Owners Corporation, University or School, we can provide a flexible, well-planned bike parking facility for your commuters, customers, employees, residents, and students.

If you are a Home Owner and need a simple solution to keep your bikes organised, we have a number of smart products that will unclutter your space in a snap.

Cora Bike Rack supplies and delivers door to door across Australia, and our product guarantees and prices are the best in the industry.

We look forward to learning more about your bicycle parking requirements and helping you choose the best solution available.

More information

For more comprehensive information on bike parking, layout guidelines, CAD drawings, online quotes and orders, please visit www.cora.com.au or call us on **1800 249 878**.

Bicycle parking standards

When selecting bicycle parking products, it is important to understand the features required for commercial applications.

While home use products are a great way to store family bikes in a secure area, commercial grade products must be vandal resistant, weather resistant and extremely durable. Cora Bike Rack products have been verified by **EcoSpecifier** to comply with Green Star and AS2890.3 guidelines which provides 3 Classes of acceptable bicycle parking facilities:

Class 3 bicycle racks and rails are designed to:

- minimise damage to a bike by supporting the bike frame (not wheel) and;
- maximise security of a bike by allowing the wheels and frame to be locked to the parking device using the cyclist's own lock.

Class 2 bicycle rooms and compounds are protected from the weather and accessed via an attendant or key system. Class 3 bike racks and rails are provided within the compound to allow secure locking of bikes.

Class 1 bicycle lockers are fully enclosed, weather protected individual lockers with unique key or electronic access.

Bicycle parking provision

In determining the appropriate Class and quantity of bike parking facilities, consideration must be given to the specific application, location and space available.

For new building developments, it is critical to consult Local and State Government requirements. In addition, Green Star and AS2890.3 list compliance guidelines for bicycle parking provision.



Cora Bike Rack Products

Page 4-5

Expo Series Multiple Bike Parking

The Cora Expo Series is the proven solution where multiple bicycle parking spaces are required in a compact space. As Australia's most popular bike rack design, the Expo Series offers an attractive, secure and versatile facility that is designed for ease of use and installation.



Page 6-9

CBR Series Bike Parking Rails

The Cora CBR Series offer a wide range of attractive and original bike rail designs that can be installed as single units or in clusters to accommodate 1 to 100's of bikes in an unlimited variety of configurations and in challenging spaces.



Page 10-11

CVR Series Vertical Mounted Bike Racks

The Cora CVR Series uses wall space or custom framing to provide space efficient vertical bike parking spaces. Best suited to indoor or covered areas such as car parks and bike rooms.



Page 12-13

CWR Series Wall Mounted Bike Racks

The Cora CWR Series makes the most of challenging and unused wall space to provide secure bike parking spaces. Best suited to indoor or covered areas such as car parks and bike rooms.



Page 14-15

CPM Series Post Mounted Bike Parking Rails

The Cora CPM Series is an innovative bike parking rail that can be mounted to existing street posts. Installation takes minutes and no drilling or removal of existing signage is required.



Page 16-19

CycleSafe Bicycle Lockers

CycleSafe® bike lockers are the #1 choice of cyclists and facility managers worldwide. Using the most durable and indestructible proprietary material in the industry, CycleSafe® offers the best bike locker solution available.



Cora Expo Series

Registered designs:
122715, 339158, 339160, 339159

Multiple Bike Parking

The Cora Expo Series is the proven solution where multiple bicycle parking spaces are required in a compact space. As Australia's most popular bike rack design, the Expo Series offers an attractive, secure and versatile facility that is designed for ease of use and installation. The Expo Series is a high density system that can be installed for single or double sided access for maximum space efficiency, and can be used for indoor and outdoor applications.

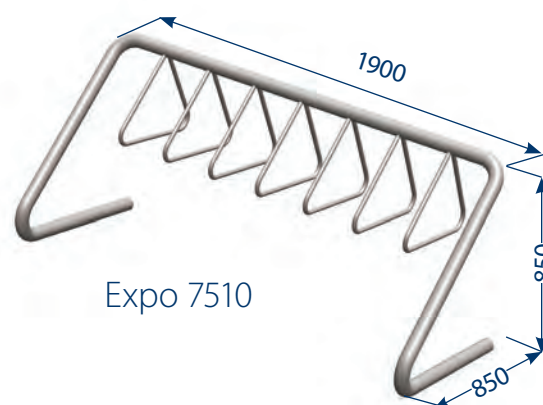
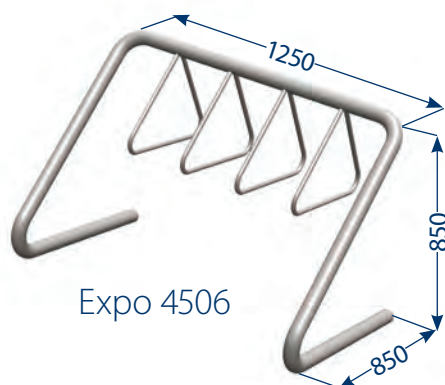
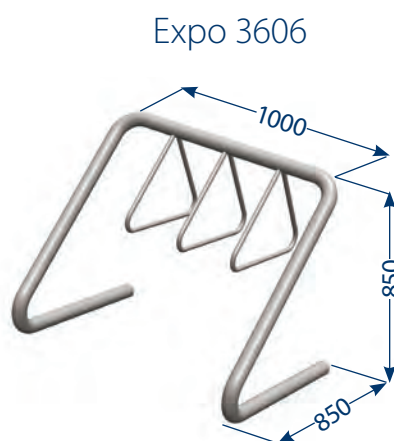
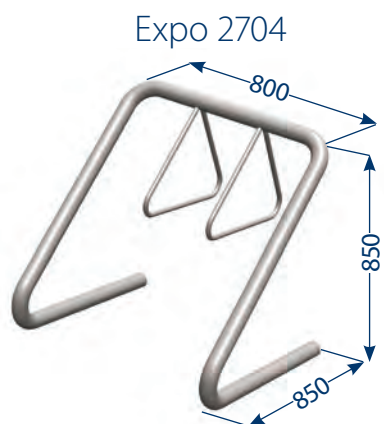

Capacity

The maximum capacity for the Expo models will depend on how the rack is positioned. Each model can be positioned on site to allow bikes to access the rack from a single side, or from both sides where space permits. Allowing double sided access provides the highest capacity with 1 bike in each alternating bay and 1 bike on each outside end. When positioned for single sided access, Cora recommends a reduced capacity to allow adequate space between bikes for easier access.

Capacity	Installation Position	Expo 2704	Expo 3606	Expo 4506	Expo 7510
	Double Sided Access	5	6	7	10
	Single Side Access	3	4	5	7

Construction Heavy duty high quality steels. Mainframe 50NB x 3.2 MD. Hangers 19m round bar.

Fixings 2 x 12mm x 125mm Stainless Steel Dynabolts with tamper resistant fasteners supplied.

Finishes **HDG** Hot dipped galvanised post-production and hand polished to ensure smooth finish.

Colour Dulux Colour powder coating on zinc electroplated frame for better colour adhesion. Not recommended for use within 2km of salt water.

316 SS Grade 316 stainless steel and Electro-polish finish. Ideal for any seaside or architecturally sensitive locations.

Layout Guide

Cora Expo Series

Single Side Access

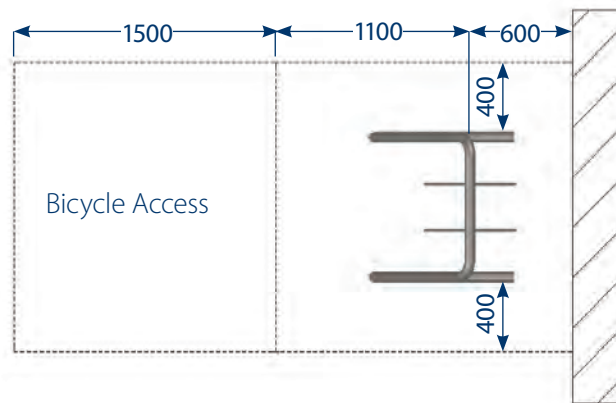

Double Side Access

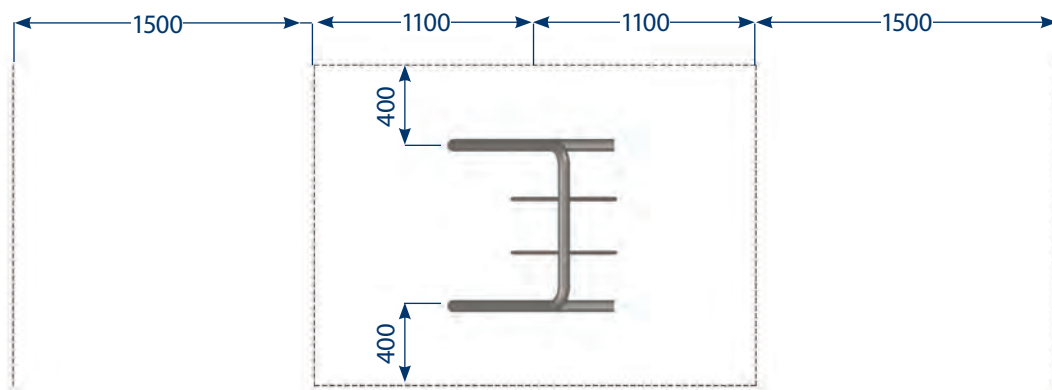

In-Line Cluster

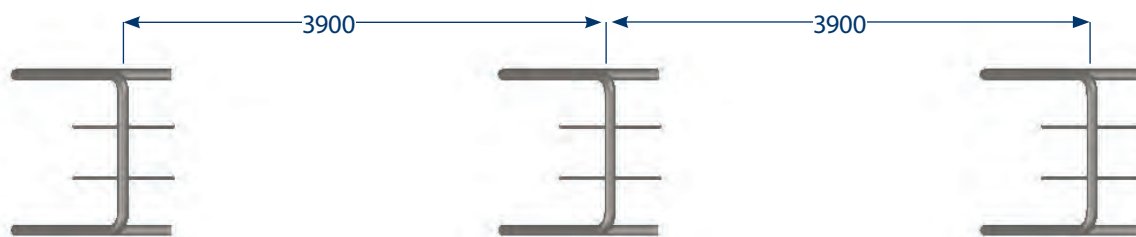

Parallel Cluster

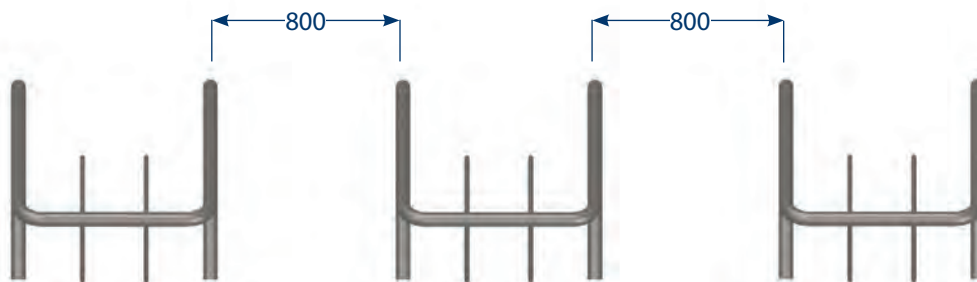

Cora CBR Series

Bike Parking Rails

The Cora CBR Series offer a wide range of attractive and original bike rail designs that can be installed as single units or in clusters to accommodate 1 to 100's of bikes in an unlimited variety of configurations and in challenging spaces. CBR Series bike rails are designed to support the entire bike frame and each unit can accommodate up to 2 bikes, with 1 bike on each side. Bolt-On and In-Situ fixing models are available in a choice of 4 finish options.

Cora CBR Series

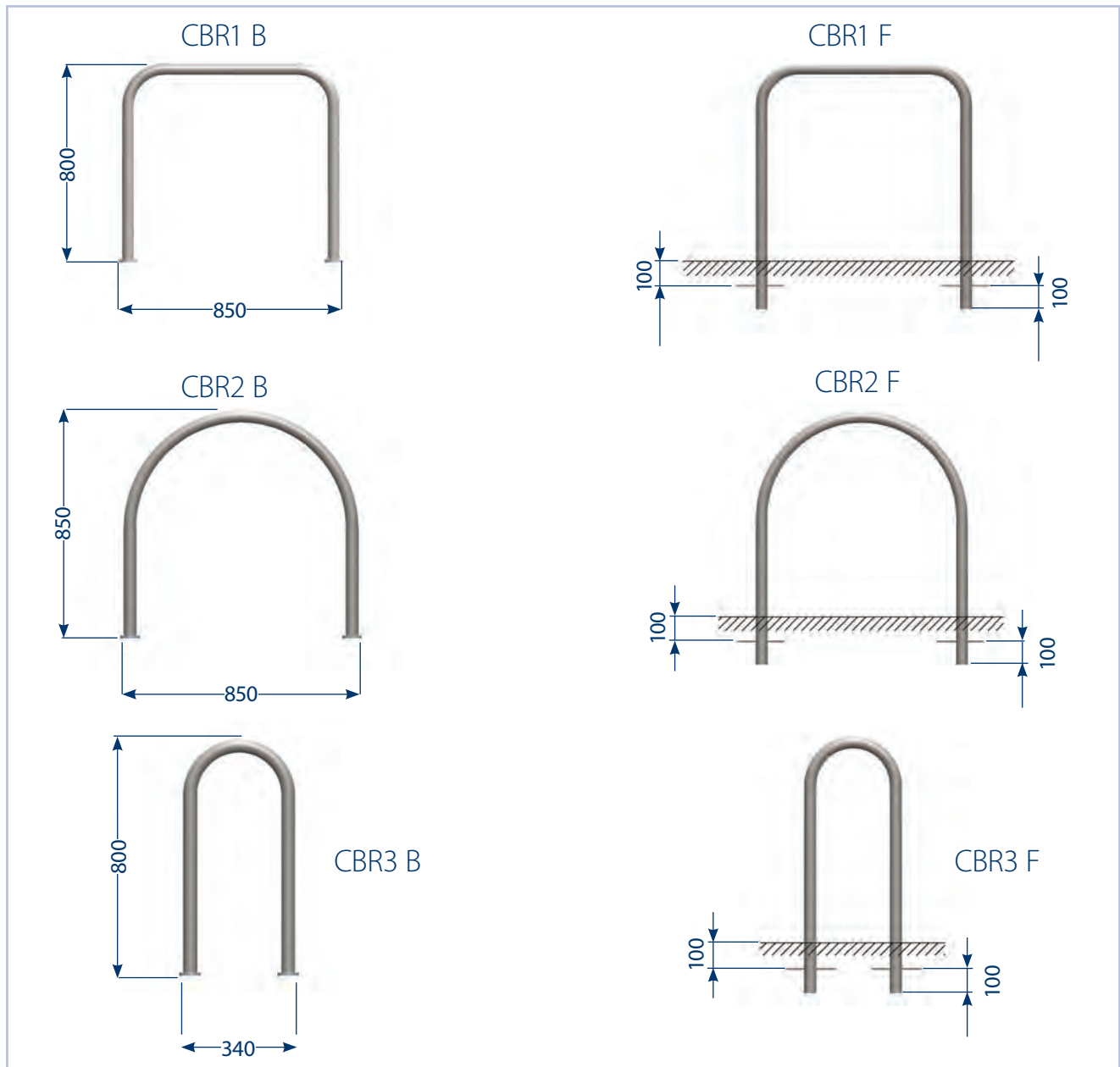

Capacity 1 or 2 bikes per rail.

Construction 40 NB (48.3mm OD) Pipe.
CBR7 uses 100mm Flat Bar.

Fixings 'B' 4 x 12mm x 75mm Stainless Steel
Dynabolts with Acorn nuts included.

'F' Concrete fix In-Situ.

Finishes

HDG Hot dipped galvanised post-production and hand polished to ensure smooth finish.

Colour Dulux Colour powder coating on zinc electroplated frame for better colour adhesion. Not recommended for use within 2km of salt water.

304 SS Grade 304 stainless steel.

316 SS Grade 316 stainless steel.

CBR4 B

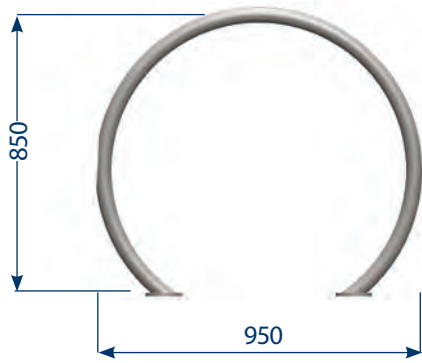

CBR4 F

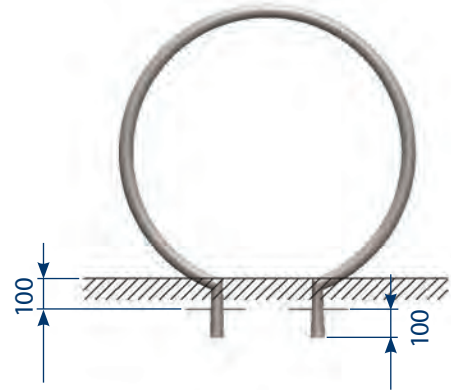

CBR5 B

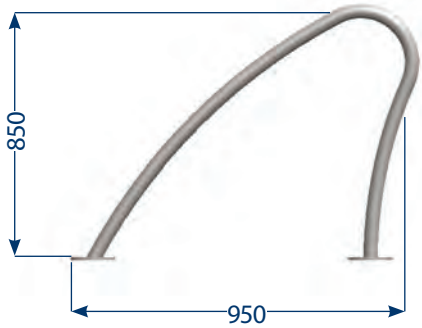

CBR5 F

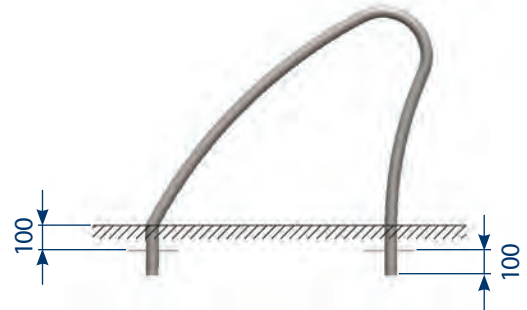

CBR6 B

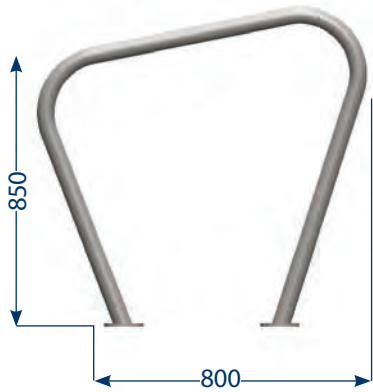

CBR6 F

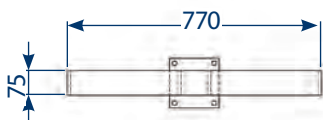
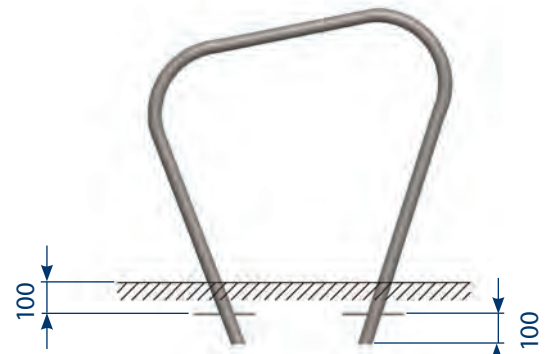

CBR7B

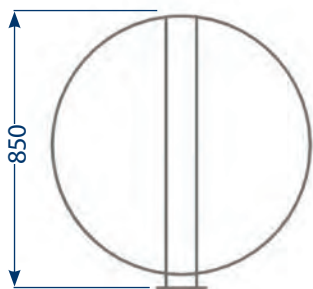

Layout Guide

Cora CBR Series

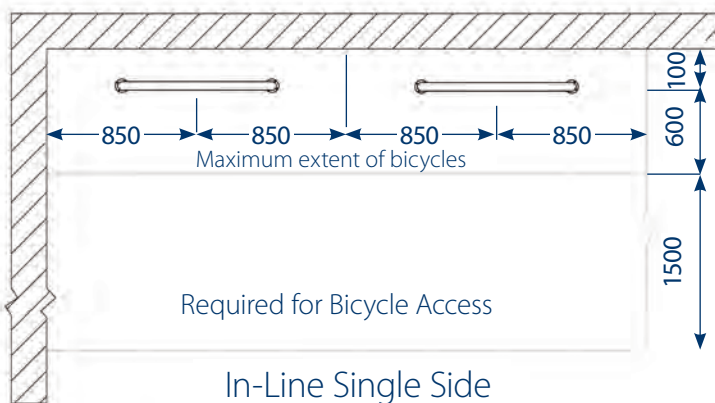
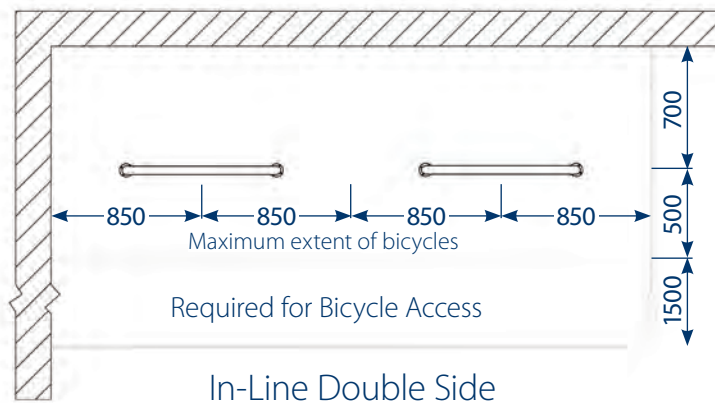
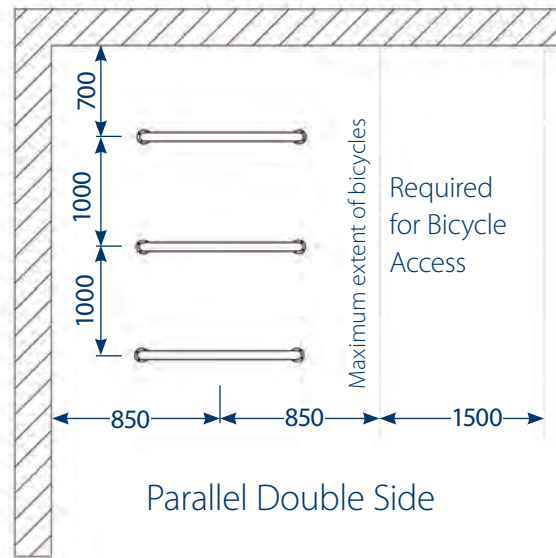

Layout Guide

Cora CBR Series

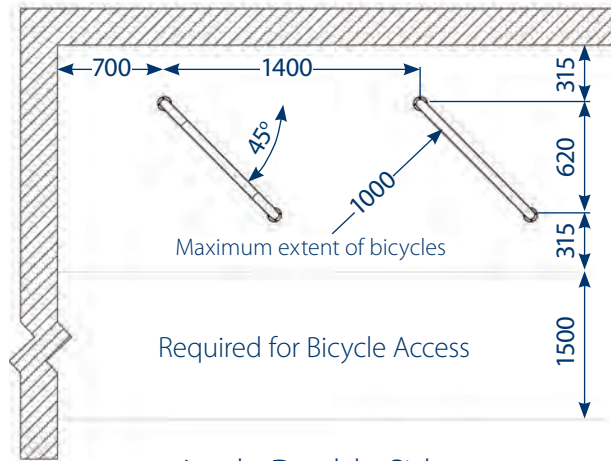

Angle Double Side

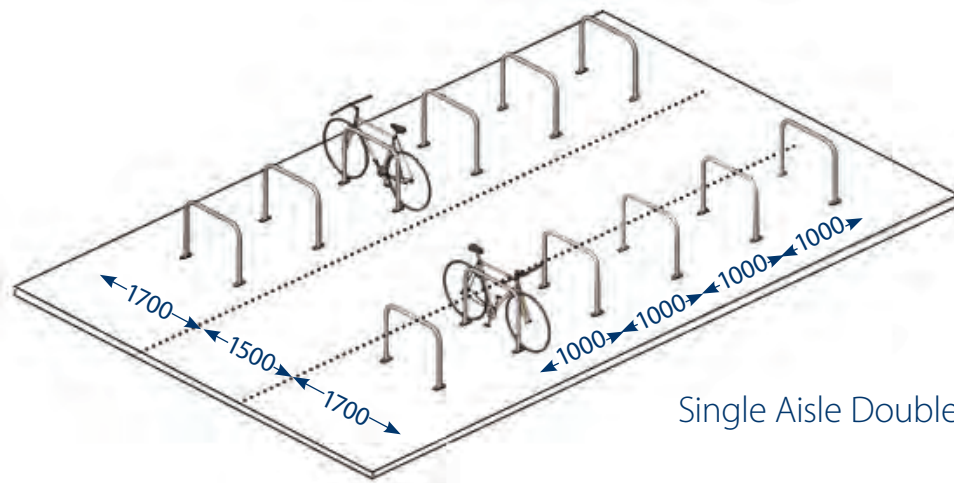

Single Aisle Double Side

Typical Bicycle Dimensions

Width 700



Height 1200

Length 1700



Cora CVR Series

Registered designs:
153687, 300245

Vertical Mounted Bike Racks

Where space is a limiting factor, Cora's CVR Series offers the perfect solution. CVR Series racks can be installed individually or in large clusters at alternating heights for maximum space efficiency. The CVR Series racks are designed for ease of use and are best suited for indoor or covered areas such as car parks and bike storage rooms. The CVR1 supports the bike by its frame, while the CVR3 supports the bike by its front wheel. In areas without walls, custom framing is available for use with the CVR3.

Cora CVR Series

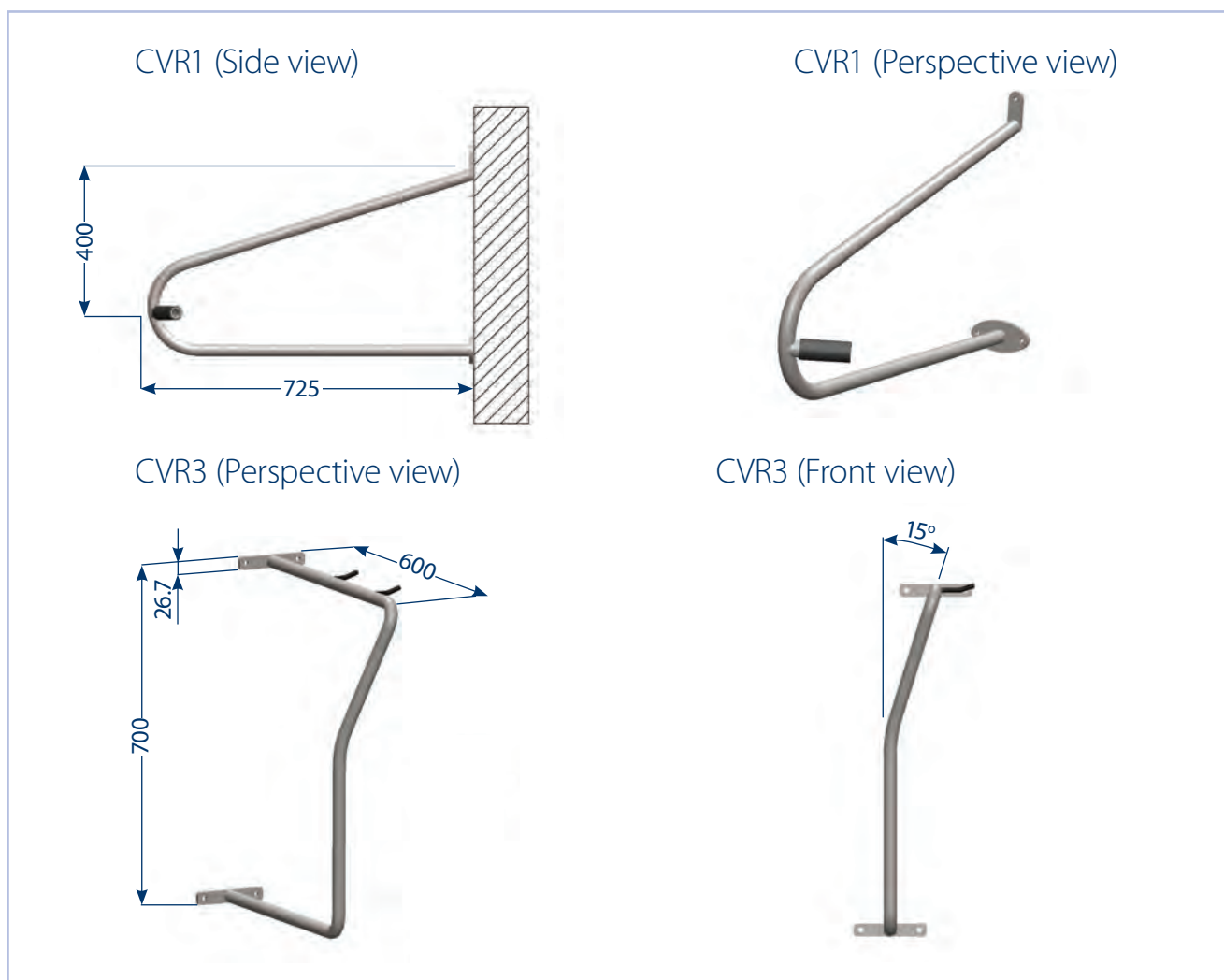

Capacity	1 bike per rail.
Construction	Heavy duty high quality steels. Mainframe 26.7mm pipe.
Fixings	3-4 x 8mm x 50mm galvanised coach screws with armour rings included.
Finishes	HDG Hot dipped galvanised post-production and hand polished to ensure smooth finish. Colour Dulux Colour powder coating. Not recommended for use within 2km of salt water. 304 SS Grade 304 stainless steel.

Layout Guide

Cora CVR Series

CVR1 (Plan view)

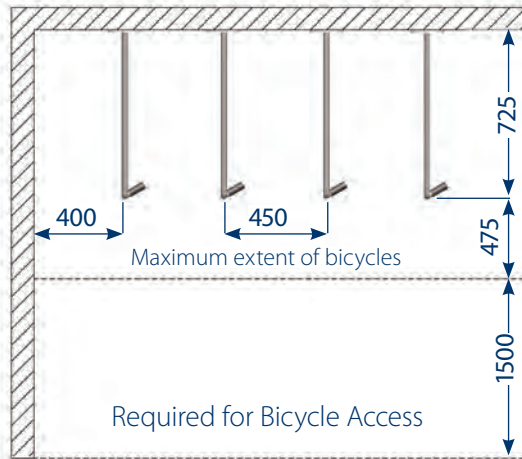

CVR1 (Front view)

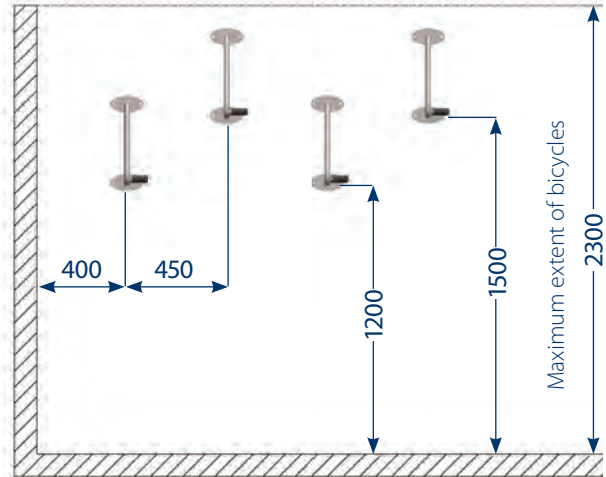

CVR3 (Plan view)

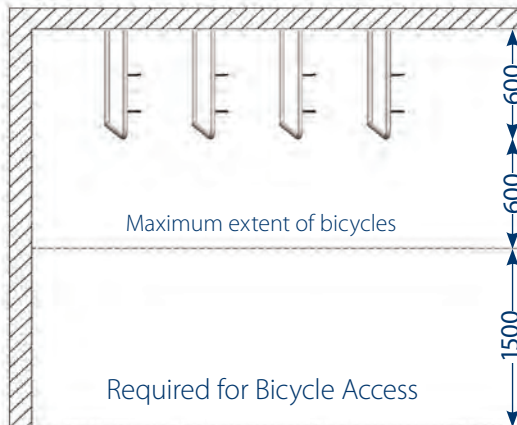

CVR3 (Front view)

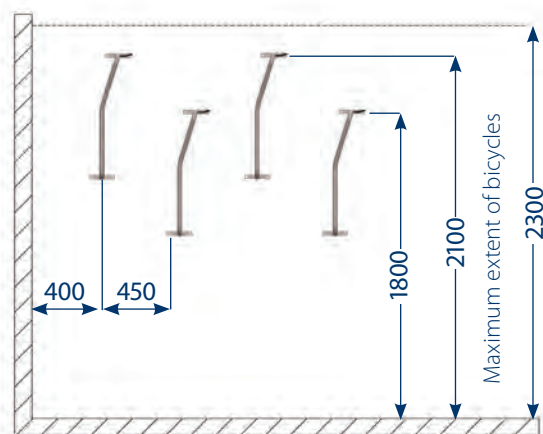

Custom framing for the CVR3 is available to fit any space:

Framing models:

- Floor to Ceiling Mount Frame
- Floor Mount Frame (shown)
- Wall Mount Frame.

Standard frame segment is 2300mm long and holds 5 bikes. Frame can be double sided to hold 10 bikes. Custom length frames available.

Cora CWR Series

Wall Mounted Bike Racks

The Cora CWR Series makes the most of challenging and unused wall areas to provide secure bike parking spaces. The CWR Series are best suited to indoor or covered areas such as car parks and bike rooms. CWR1 provides a secure anchoring point for bikes that are simply leaning against open wall space. CWR2 holds 1–2 racks in a horizontal position at any height such as above a car bonnet. Each bike can be locked separately, however the front bike must be removed to access the rear bike.

Cora CWR Series

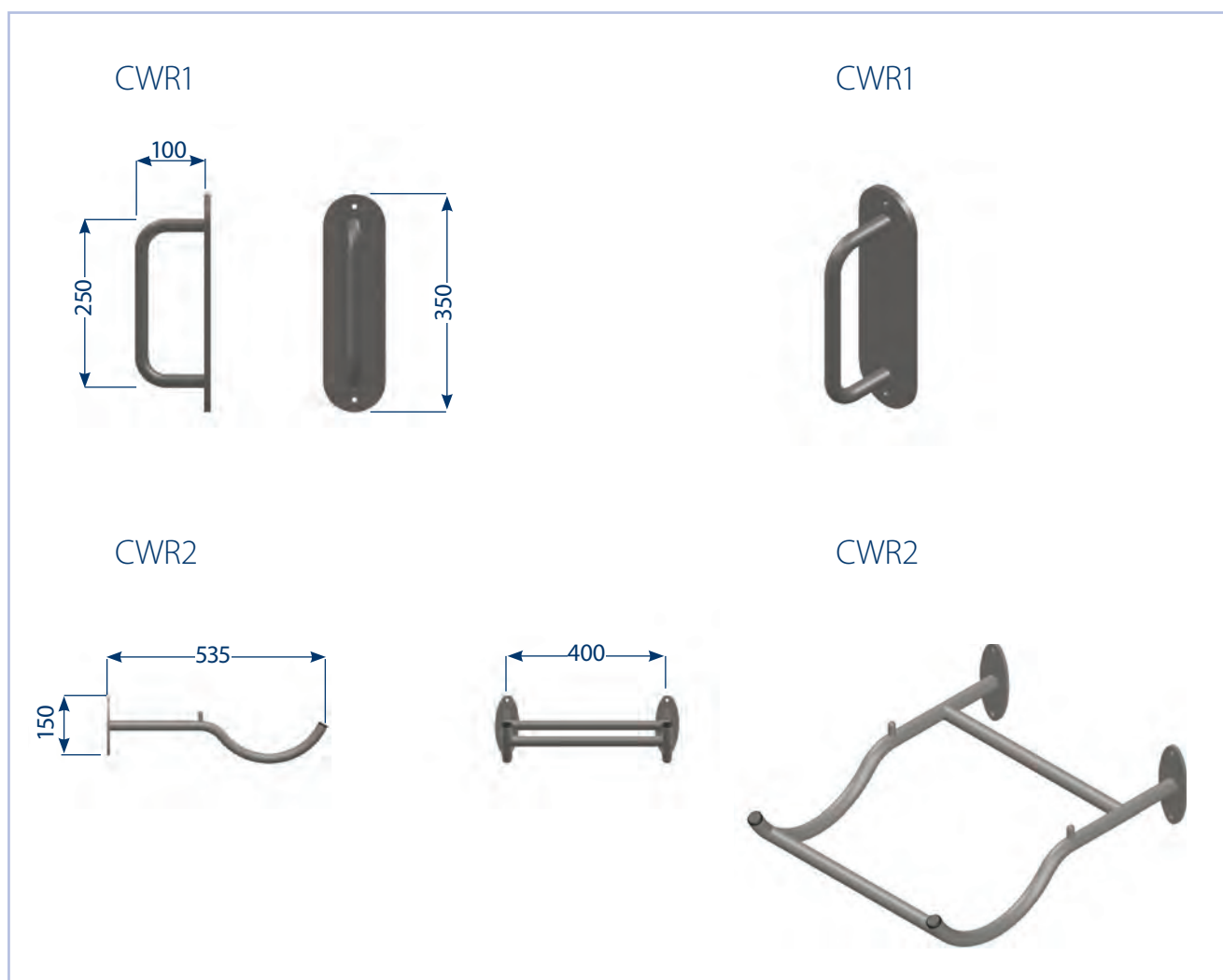

Capacity	CWR1 1 bike CWR2 1–2 bikes
Construction	Heavy duty high quality steels. CWR1 15mm pipe; CWR2 25mm pipe.
Fixings	CWR1 2 x 8mm x 50mm; CWR2 4 x 8 x 50mm galvanised coach screws with armour rings included.
Finishes	HDG Hot dipped galvanised post-production and hand polished to ensure smooth finish. Colour Dulux Colour powder coating. Not recommended for use within 2km of salt water. 304 SS Grade 304 stainless steel.

Layout Guide

Cora CWR Series

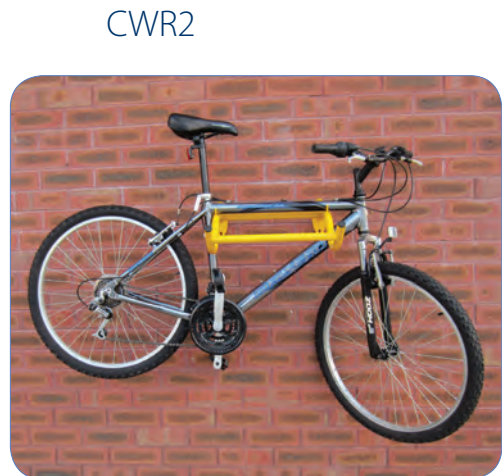
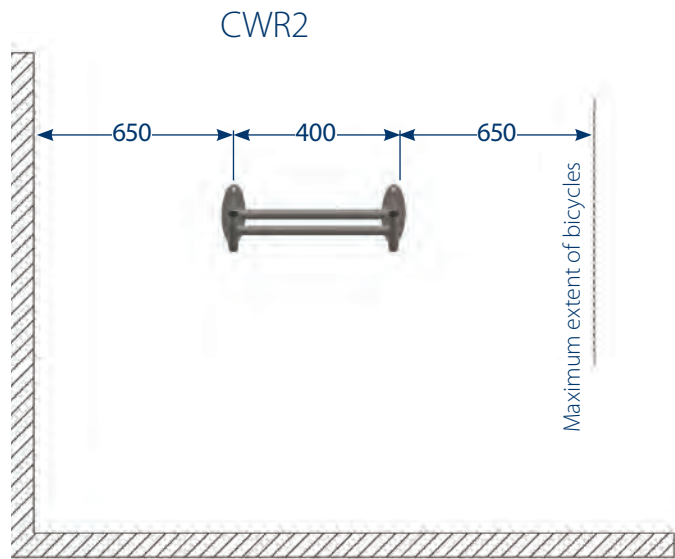
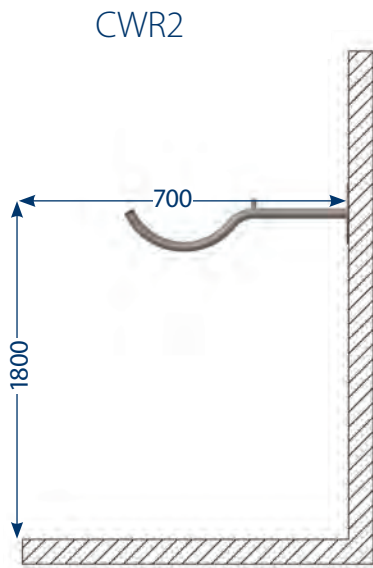
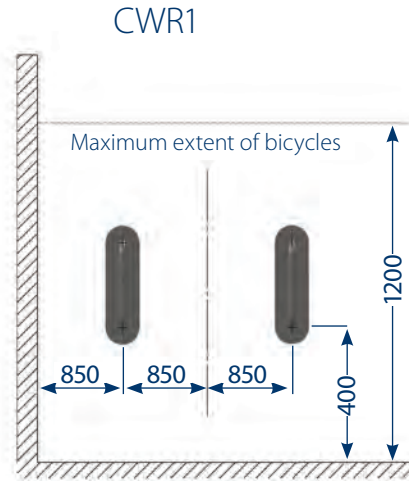
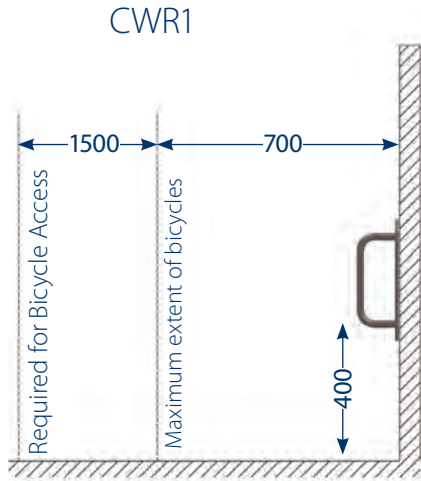

Cora CPM Series

Post Mounted Bike Parking Rails

The Cora CPM Series is an innovative bike parking rail that can be mounted to existing street sign poles and posts. Installation takes minutes as no drilling or removal of existing signage is required. The CPM Series bike rail supports the entire bike frame and allows locking of both wheels and frame. With the CPM Series, it's now easy to provide secure bike parking facilities on all city streets.

Cora CPM Series

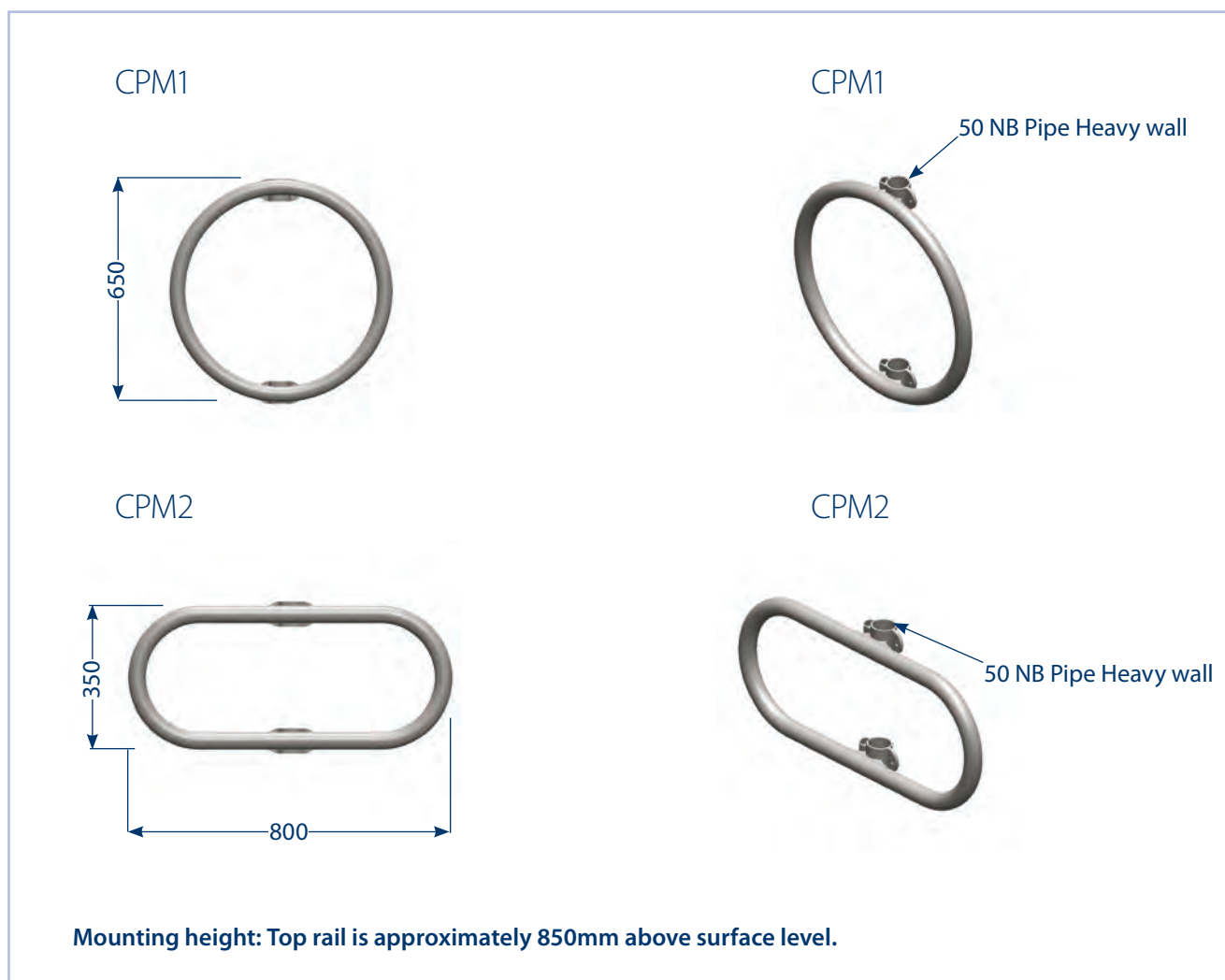

- Capacity** 1 bike per rail
- Construction** Heavy duty high quality steels. Mainframe 40NB pipe
- Fixings** Pipe Clamp-On™ attaches to 40NB and 50NB posts without drilling or removing existing signage. Supplied with tapped M8 torx screw.
- Finishes**
 - HDG** Hot dipped galvanised post-production and hand polished to ensure smooth finish.
 - Colour** Dulux Colour powder coating. Not recommended for use within 2km of salt water.
 - 304 SS** Grade 304 stainless steel.



CycleSafe® Bicycle Lockers

Bicycle lockers offer the highest level of bicycle security and are suitable for residential buildings, commercial offices, education facilities and public transport hubs.

As bicycle lockers require a significant financial investment it is important to select a product with a proven record in security, durability, performance and quality.

CycleSafe® bicycle lockers are the #1 choice for cyclists and transport authorities worldwide. With over 10 million users a year and no reported thefts in over 30 years of service, it easy to see why.

CycleSafe lockers are manufactured with a proprietary high density polyester sheet moulding compound (SMC). CycleSafe's SMC is a compression moulded thermoset composite material that produces a virtually indestructible product with a lifespan measured in decades, not years. CycleSafe's SMC composite material will not crack, dent, warp, corrode or sustain UV degradation.

CycleSafe's vandal-deterrent structure is impenetrable to pry bars and knives, and with the additional benefit of graffiti-resistant coatings and low maintenance requirements, CycleSafe® lockers provide the lowest cost of ownership in the industry.

CycleSafe® Product Range

EcoPark® Series

A freestanding modular system suitable for most applications. Constructed with CMC composite door and roof segments, and 16 gauge reinforced sheet metal side panels.

ProPark® Series

An interlocking modular system suitable for the highest risk areas. Fully constructed with CycleSafe's CMC composite to provide the ultimate in bicycle security.

Product Features and Comparison	EcoPark	ProPark
SMC composite door and roof construction	✓	✓
SMC composite side panels	✗	✓
16 gauge zinc primed TGIC powder coated side panels	✓	✗
Integral ribbing to maximise strength and stiffness	✓	✓
Integral UV and Graffiti resistant coatings	✓	✓
ABLOY Executive locking mechanism (best available)	✗	✓
Chicago Ace II locking mechanism (very good)	✓	✗
High security full length door latch system	✓	✓
Minimal thermal conductance	✓	✓
Re-locatable and expandable	✓	✓
Height and levelling adjustments	✓	✓
1 or 2 door models	✓	✓
Double tier models available	✗	✓
Interlocking modular system	✗	✓
Freestanding modular system	✓	✗
Shipped in kit form for onsite assembly	✓	✓
Locker width	850mm	1000mm
Price	**	***

CycleSafe® EcoPark™ and ProPark™

CycleSafe Models

EcoPark™

EP2 This double sided bicycle locker has 2 doors to allow access from both sides, with an interior partition to provide 2 individual secure bike spaces. Where only 1 door is required, simply lock the unused door and assemble the EcoPark locker without using the internal partition to allow secure parking for 1 or 2 bikes. Each EP locker unit is a complete freestanding locker.

ProPark™

As an interlocking system, the first ProPark locker to start each row is called a 'starter unit' and each additional locker that attaches to the row is called an 'adder unit.' When placing and order it is important to advise how many 'starter units' and how many 'adder units' are required to ensure the correct locker modules are provided. There are 4 ProPark models:

PP1: This single sided model has 1 door to allow access from only one side, permitting the unit to be placed up against a building or barrier. 1 or 2 bikes can be stored without an interior partition.

PP2: This double sided model has 2 doors to allow access from both sides, with an interior partition to provide 2 individual secure bike spaces.

ProPark™ Upper Tier Models

PP1U: The PP1U Model has 1 door for placement on top of PP1 Models. The locking mechanism is located at the base of the PP1U model for easy access, and a holdback mechanism props the door open for ease of use. 1 or 2 bikes can be stored without an interior partition.

PP2U: The PP2U Model has 2 doors for placement on top of PP2 Models. The locking mechanism is located at the base of the PP2U model for easy access, and a holdback mechanism props the door open for ease of use. 2 individual and secure bike spaces.

Options – add these additional features to the above models if required. Please allow additional delivery time.

MSH: Metal Swing Handles (MSH) replace the high security locks that are included with EcoPark and ProPark™ lockers. The MSH accepts U-locks and padlocks, and is suitable where cyclists are expected to provide their own lock.

PosterGrip: Custom sized PosterGrip snap-in frame allows the ability to display and change information or advertising signage on EcoPark and ProPark™ end panels.

VTD: ViewThru™ Doors are available for ProPark lockers only and have a 28cm x 28cm weatherproof, shatterproof Polycarbonate window to provide property managers and authorities the ability to monitor locker contents or usage for security purposes.

Colour: The standard EcoPark and ProPark™ colour is Sandstone. Custom colours can be order for additional cost and will incur extended delivery times.

Setting the Standard for Secure Bicycle Parking

- Awarded first bicycle storage patent issued in the US
- Industry's most durable locker with a 30 year proven product life
- No reported cases of bicycle theft
- Manufactured to ISO 9000 and 1400 requirements
- Complies with AS2890.3 Class 1 and contributes to Green Star points

Layout Guide

EcoPark™ Series

EP2

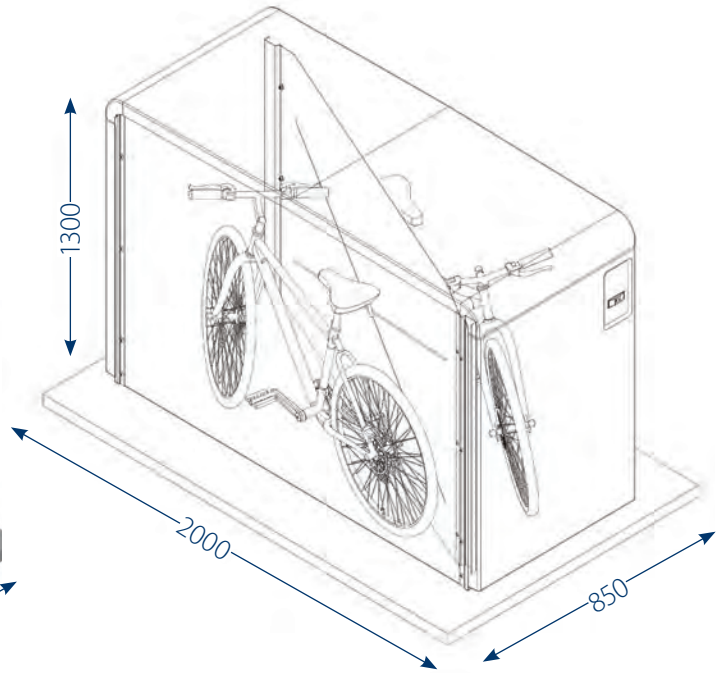
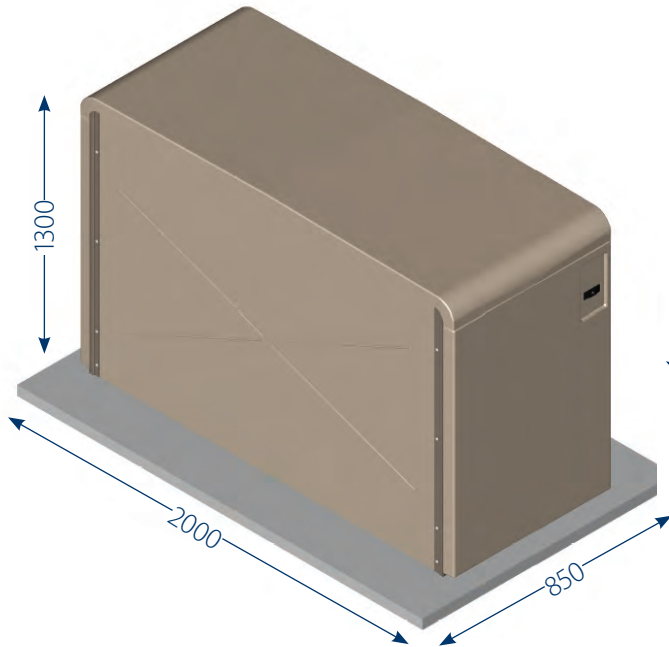

EP2 (Plan view – two door use)

EP2 (Plan view – single door use)

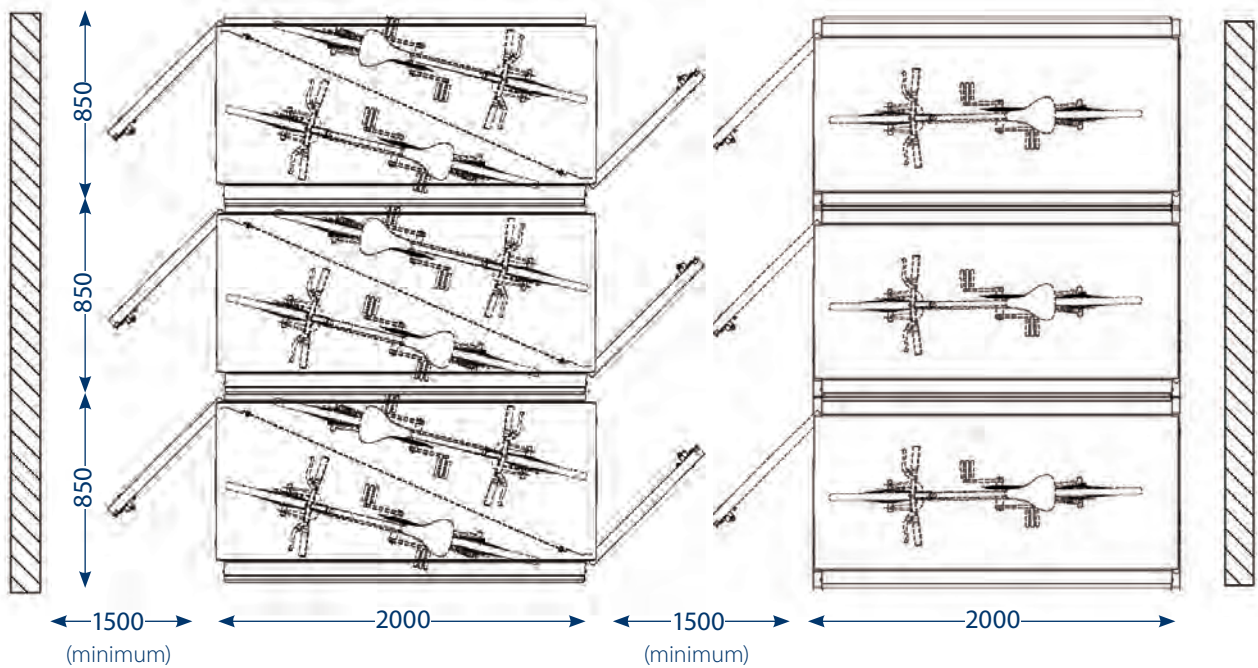

Layout Guide

ProPark™ Series

PP1 or PP2

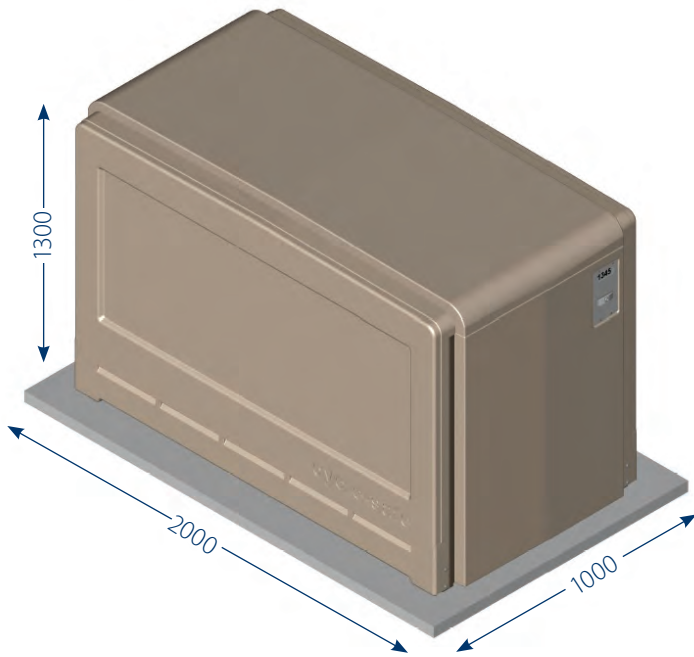

PP1U or PP2U
(Upper unit)

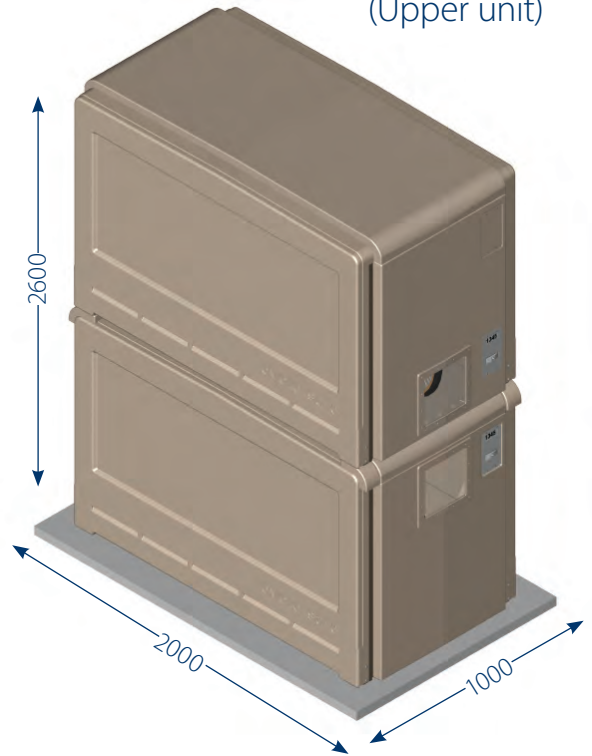

PP2 (Plan view)

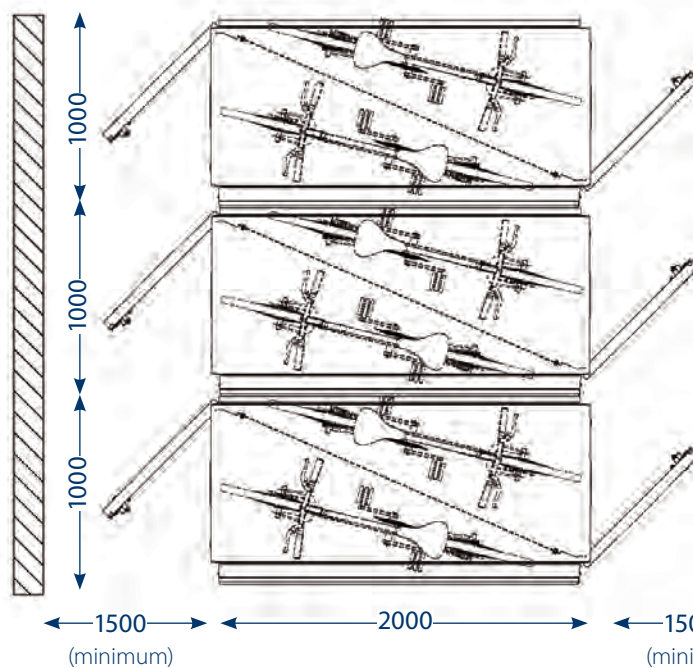

PP1 (Plan view)

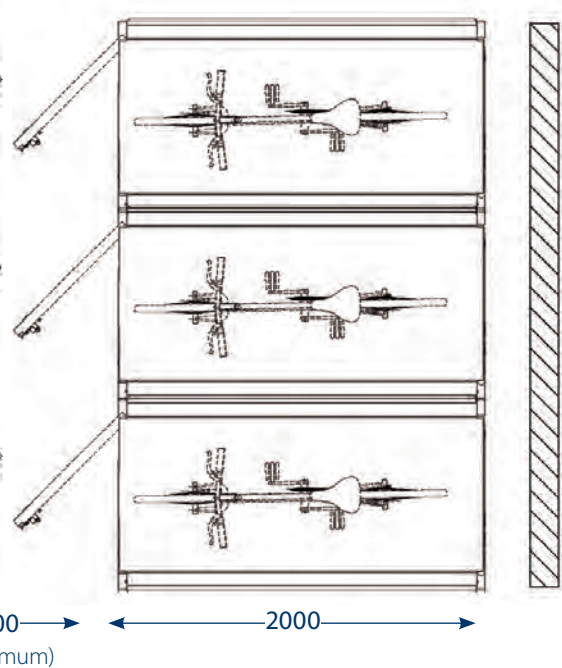

Specification



To fully specify Cora Bike Rack products, please include the product code, finish and quantity required.

Quotes & Orders

Need a Quote or ready to place an Order? Simply choose from the following options:



Online

If you know the product models, finish and quantity you require, you can create a Quote or place an Order instantly online at: www.cora.com.au



Email

Send your quote requests by email 24/7 and we will promptly return our Quote & Order form: sales@cora.com.au



Fax

You can fax your Purchase Orders or Quote requests any time to fax: [1800-249-879](tel:1800-249-879)



Not sure what you need?

We can assist with all of your questions.
Call us at ph: [1800-249-878](tel:1800-249-878)