

Billi<sup>™</sup> Quadra



Filtered boiling  
and chilled  
drinking water  
system

New Billi **Quadra**... is the ultimate drinking water appliance providing the convenience of an instant supply of refreshing and invigorating filtered water, both boiling and chilled.

Futuristic in design yet timeless in styling, Billi **Quadra** will never cease to impress and satisfy with its neat underbench installation and amazing array of user-friendly functions.



Billi **Quadra**... a new generation drinking water system

#### **Building design and ESD**

A growing awareness of the responsibilities of Ecologically Sustainable Development (ESD) is emerging. A new total building objective known as Green Building Design, places emphasis on energy and water saving efficiencies, recyclability and material choices with low embodied energy coefficients. The total commitment of Billi to ESD is reaffirmed with the introduction of the new **Quadra** and **Quadra Plus**. Setting new standards of high energy efficiency, space efficiency and environmental sensitivity, the **Quadra** accords with Green Building Design objectives.

#### **Recovery, recycling and saving**

Billi's Thermodynamic Heat-Exchange technology is a technological breakthrough in energy efficient appliance design. The unique technology recovers the waste heat energy, generated during the chilling cycle, and uses it to preheat the boiling water. Billi's Heat-Exchange technology enables the system to achieve substantial power savings, fully in accordance with ESD initiatives.

#### **Insulation conservation**

The **Quadra**'s energy efficiency is further enhanced with the use of high-performance insulating materials. Moulded expanded polypropylene provides a high thermal R-value rating, reducing heat losses and thereby conserving power.

#### **Time is money**

An inbuilt 7-day energy saving time switch ensures the **Quadra** is only operating when you need it, significantly reducing running costs by eliminating unnecessary out-of-hours power consumption.

#### **Standing by to save**

An energy-saving standby mode can be selected to activate after a preset period of non-use. The hot water temperature is lowered to conserve power. At a touch of either dispenser lever, the **Quadra** will resume its normal operating mode, to provide boiling and chilled water.

#### **Space-saving superiority**

Billi **Quadra** is an outstanding exponent of space-saving efficiency. The **Quadra** underbench module is around half the size of other brand units. **Quadra**'s compact, neat outer dimensions allow it to fit comfortably within a standard shelf compartment.

#### **Recyclability**

In line with long-term ESD responsibilities, individual parts used in the **Quadra** are marked with an internationally recognised recycling identification code.



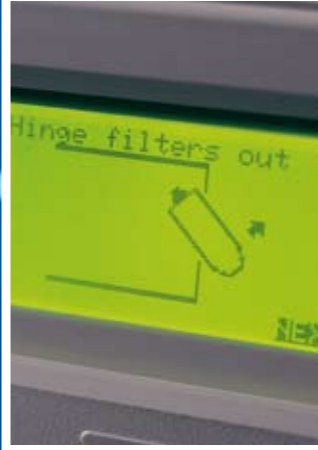

## Innovative Billi **Quadra** design... a pleasure to use

### **Elegant and functional**

The elegantly styled and ergonomically designed Billi **Quadra** dispenser is a pleasure to use. Colour-coded levers are position-sensitive, allowing control of boiling water flow rate. Levers can be pressed for single cup delivery or lifted for continuous flow. A swivel action allows the dispenser to be swung out of the way if more sink space is required. Cast from solid metal alloy, the **Quadra** dispenser is designed to withstand the rigours of high-use environments. Available in a choice of architectural finishes.

### **Intelligence you can see**

You are never kept in the dark with the Billi **Quadra**. A back-lit LCD display panel constantly advises as to its operation. Should any difficulties arise, a help button activates an assistance menu to guide users through the problem. Programming is simple and important usage data is easily accessed. User instructions such as 'How to change filters' are shown as step-by-step moving graphic images.

Time adjustments at the beginning and end of daylight saving are easy with Billi's Daylight Saving Mode. Simply press the daylight saving 'start' or 'finish' button and the time is immediately corrected.

### **Advanced filtration for great tasting water**

Sparkling clean, filtered water is nature's most refreshing drink and the Billi **Quadra** features an all-new, advanced boiling and chilled water filtration system that provides sparkling fresh water. Hygienic and convenient dual filter cartridges<sup>†</sup> ensure maximum effectiveness and extended service life.

### **Easy-change replacement filters**

Replacing the **Quadra** filter cartridges couldn't be simpler. Flashing amber dispenser icons indicate when replacement is due. The swing-change filters simply swing forward and slide off. Fitting the new filters is just as easy: slide filters in and swing back. Cartridges lock into place and a flushing cycle begins automatically.

### **User safety**

User safety is paramount in the design of the **Quadra** Dual-Temp Dispenser. Its heat-insulated body and concealed childproof safety-switch ensure a high level of user protection, a must for childcare and aged care facilities. Water flow is electronically varied, slowing momentarily as water first enters the cup for smooth, splash-free delivery.

### **Instant Boiling Water**

To ensure your hot water is delivered as close to boiling point as possible, the **Quadra** features the automatic self-calibrating Autocal electronic temperature regulation system. Innovative delivery and recovery controls ensure temperature is maintained during periods of heavy boiling water usage.

### **Billi Font – water where you want it**

The stainless steel Billi Font harmonises perfectly with the new **Quadra** Dual-Temp dispenser and allows installation away from the traditional sink area. Designers have greater flexibility as the Billi Font can be easily installed where it is most needed.

<sup>†</sup>Quadra Compact uses a single dual-stage filter.

## Unique Billi **Quadra** features



### Billi **Quadra Plus** – a major breakthrough in design

The Billi **Quadra Plus** not only dispenses filtered boiling and chilled drinking water – it also provides the added feature of a generous supply of instant hot water (up to 50°C). This hot water supply can be mixed with cold water and is dispensed via a separate Sink Mixer Tap, removing the need for bulky underbench hot water cylinders or energy-wasting hot water reticulation systems. For full details, refer to the separate **Quadra Plus** brochure.

### Water Cooled – no ventilation required

Water cooled **Quadra** has evolved from Billi's original innovative concept. Extremely quiet in operation, it requires no cupboard ventilation, cooling fan or coil. Additionally, the new Heat-Cell technology ensures that water usage is absolutely minimal, reflecting Billi's responsible water management.

### Air Cooled option

Air cooled **Quadra** may be selected as an option. These units generate far less heat than other air cooled systems and require no cooling water to be released. Air cooled **Quadra** models require cupboard ventilation to allow efficient dissipation of heat and may be linked to a thermostat controlled booster fan vent to aid the efficient operation of the fan-coil unit.

### Disability conscious design

Billi **Quadra**'s ergonomic design accords with current Australian Standards for ease of use for persons with a disability.

### Service friendly

'Ease of Service' was an important consideration in the **Quadra** design brief. Items which require periodic servicing are easily accessed without the need to remove the unit from the cupboard.

### Leakguard detection system

For peace of mind, the Billi **Quadra** features a watertight base tray and water detection system. Should water leakage ever occur, water supply to the system will be instantly shut off.

### Commitment to quality

Reliability has been engineered into the Billi **Quadra** as an imperative in the design process. Proven, high quality materials have been carefully selected for maximum dependability and longevity. Manufactured to strict quality standards, the **Quadra** is built for performance over the long term. **Quadra**'s generous warranty is a reflection of Billi's long-term commitment to quality.

### Options and accessories

- Dispenser finishes: Standard finish for the **Quadra** dispenser is bright chrome. Optional finishes include Brushed and Black Chrome.
- Billi Font: Allows the **Quadra** to be located away from sink areas. Finished in polished Stainless Steel. Optional finishes include Brushed and Black Chrome.
- Dispenser riser: 70mm dispenser extension – supplied standard with the Billi Font.
- 1000mm Extension Kit: Available for installations where the dispenser needs to be offset from the underbench unit.
- Vent Kit for AC<sup>^</sup> units: Standard or booster-fan versions are available.

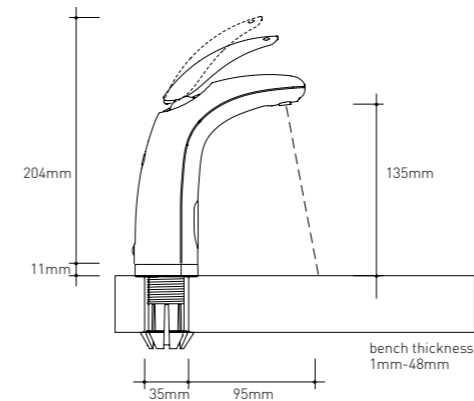

Billi Dual-Temp Dispenser dimensions

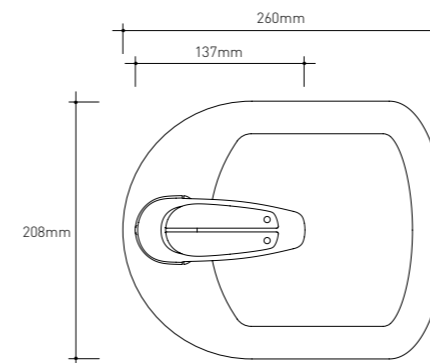

Billi Font benchtop layout (Dual-Temp only)

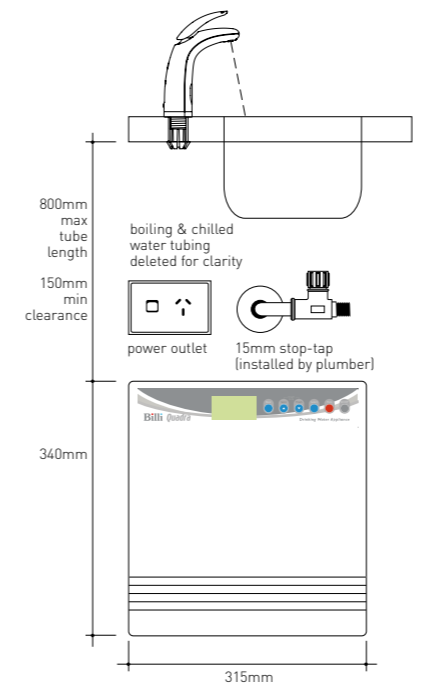

Minimum cupboard dimensions:  
**Water-cooled unit:** 475mm depth x 335mm width  
**Air-cooled unit:** 520mm depth x 365mm width

Preferred installation layout

## Billi **Quadra**... easy to install

### Easy installation

The Billi **Quadra** Dual-Temp Dispenser features a unique dispenser top-mounting system, making it a plumber's dream to install. No more tortuous reaching up behind sink bowls to secure clamps or tubes. The 'snap-fit' base is secured into the mounting hole, pipework is fed through from the top and the dispenser securely clips into place.

### Water supply

A single 15mm (1/2") stop-tap with a male thread should be installed in an easily accessible position. Water supply must be microbiologically safe to drink, with a minimum dynamic water pressure of 250kPa.

### Power supply

Most **Quadra** models require a standard 10 Amp power outlet. **Quadra 4100** and **Quadra Plus 15** models require a 15 Amp power outlet while the **Quadra 4180** requires a 20 Amp power outlet in the cupboard area where the unit is to be installed. All models are supplied with a 1 metre flex cord and plug.

### Replacement filters

Periodic replacement of filter cartridges is necessary to maintain water quality. Genuine replacement Billi filter cartridges are available from authorised Billi agents. Cartridges are also available to suit the needs of different water supply areas. Optional sub micron rated filters are NSF certified to safely remove health threatening giardia and cryptosporidium.

### Warranty

At Billi, we stand behind all of our products and offer a generous **5 year pro rata warranty** on Billi **Quadra**'s stainless steel boiling water tank. All other components are covered by a **12 month warranty**. Filter cartridges are a consumable and are not covered by warranty, as water conditions and usage vary.

### Certifications

Every Billi drinking water appliance is manufactured under a certified quality control system. The Billi **Quadra** has been tested and complies with all required standards including: Watermark Licence Number 21525; Tested to AS3498 and AS/NZS4020; AS/NZS ISO 9001 Certificate Number QEC 11627; C-Tick approved; Complies with AS1428 Requirements for Access for the Disabled and section J6 of the BCA. Electrical compliance number CS100600V.

### Specifications and guide to model selection

Product Code	Billi <b>Quadra</b> model	Initial cup delivery and suggested no. of persons**	Boiling water delivery cups per hour	Chilled water delivery cups per hour	Total current draw amps	Height mm	Width mm	Depth water-cooled	Depth air-cooled*
904010	Quadra Compact	up to 16	100	150	7	340	315	365	410
904020	Quadra 420	up to 24	120	175	8	340	315	465	510
904040	Quadra 440	up to 40	150	175	8	340	315	465	510
904060	Quadra 460	up to 60	180	175	10	340	315	465	510
904100	Quadra 4100	up to 100	250	175	15	340	315	465	510
904180	Quadra 4180	up to 180	350	175	20	340	315	465	510

Product Code	Billi <b>Quadra Plus</b> model	50°C hot water capacity litres	50°C hot water delivery litres per hour**	Boiling water delivery cups per hour	Chilled water delivery cups per hour	Current draw amps	Height mm	Width mm	Depth water-cooled
904025	Quadra Plus 5	7	40	120	175	8	340	315	465
904065	Quadra Plus 9	9	60	180	175	10	340	315	465
904105	Quadra Plus 15	15	85	250	175	15	340	315	465

1 cup = 170ml. \*\* Based on the initial number of cups of boiling water immediately available, drawn at one cup every 10 seconds. Consideration may be needed for usage patterns and draw-off methods.

\*When specifying Billi Quadra air-cooled models, insert AC after model number eg: Quadra 440 AC

\*\* A reserve of boiling water is still available after hot water is fully drawn. Depth of Quadra Plus air-cooled models is 510mm.



**Billi Pty Ltd**

42 Lucknow Crescent Thomastown  
Victoria 3074 Australia  
Telephone +61 3 9469 0400  
Facsimile +61 3 9469 0499  
Website [www.billi.com.au](http://www.billi.com.au)

**Designed and manufactured in Australia**

As Billi Pty Ltd has a policy of continual improvement, all details are subject to change without notice. All goods are sold subject to our published terms and conditions.

Billi is a registered Trade Mark.  
Quadra is a Trade Mark. 0910